

Vision Sensor

# F150-3

*Perform settings in a conversational manner. The dialog menu artist "talks" to you.*

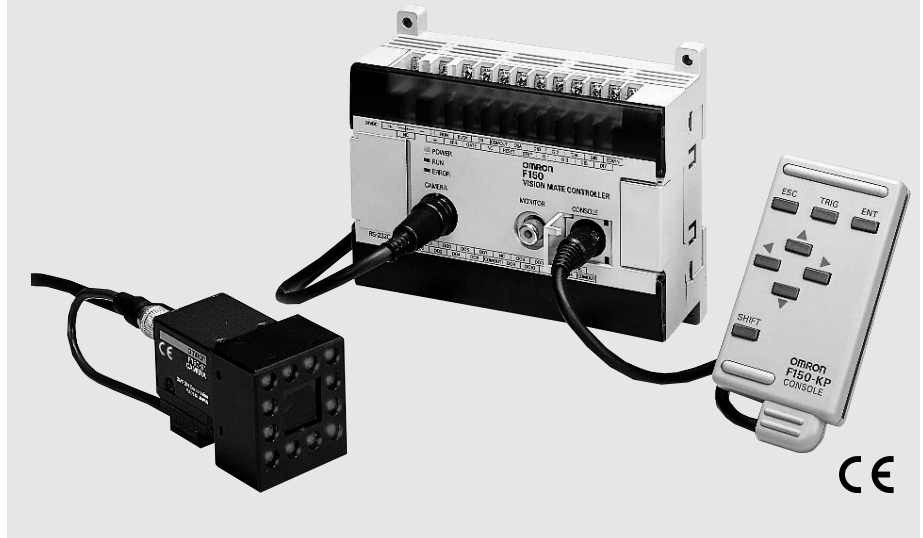

F150-3

## Features

### Intelligent lighting

Various types of lighting control make it possible to obtain a clear, stable image suitable for the inspection. The dome shape minimizes the effects of external light and permits damage inspection. Red and green light is mixed to allow inspection of a wide range of work.

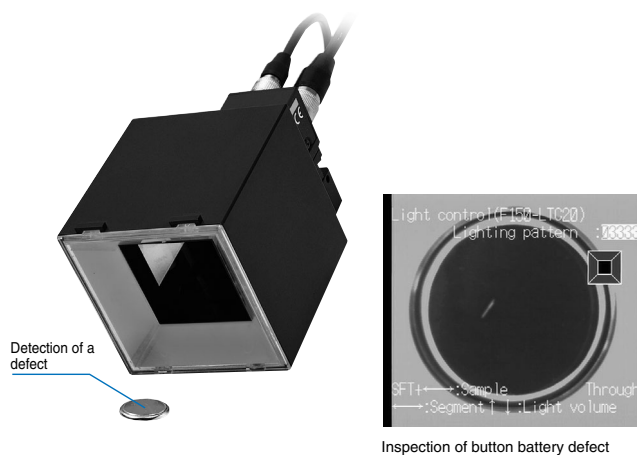

### Variety of lighting methods

The direction of lighting and the brightness can be changed. Coaxial lighting is also possible with the F150-SLC20. The optimum lighting method for the work can be selected.

#### F150-SLC20 (Field of view: 20 mm)

Light intensity can be set separately to one of 8 levels for 5 illuminated areas.

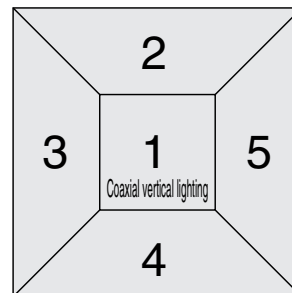

#### F150-SLC50 (Field of view: 50 mm)

Light intensity can be set separately to one of 8 levels for 8 illuminated areas.

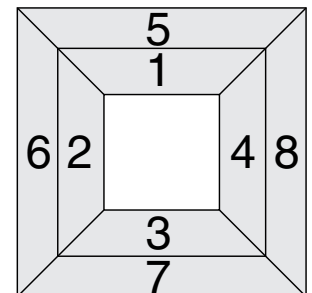

### Control lighting from the menu

- The illumination area and light intensity are controlled from the controller menu. Settings can be easily changed without handling the lighting.
- The lighting is also treated as scene data, and thus can be changed along with other conditions when the model is changed.
- The controller manages the lighting setting as a digital value. This increases the reproducibility of the setting.

Features

Integrated camera and lens

Camera setup is easy because the object-imaging camera is integrated into a single unit with the lighting apparatus and lens.

2-camera unit

We have made bi-directional, 2-line inspection easy and inexpensive.



A variety of image read-in methods

Images from two cameras can be read in at the same time. Read-in methods include successive changeover between the two cameras, and combination of the image from each camera into a single image.

Two-camera Switching

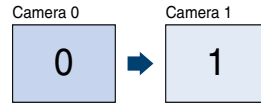

Vertical Composition

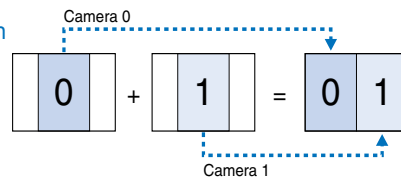

Horizontal Composition 1

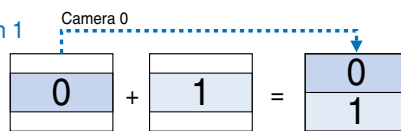

Horizontal Composition 2

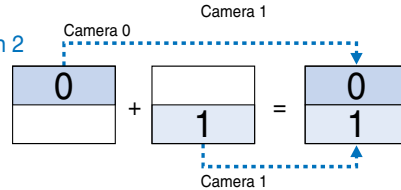

Example of application using two cameras

Inspecting Boxes From Both Side

Simultaneously inspect both sides of a box using two cameras.

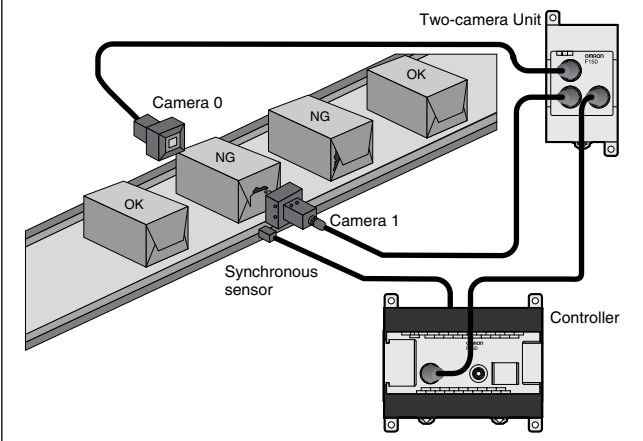

PCB Positioning

Determine the coordinates of position marks using two fields of vision.

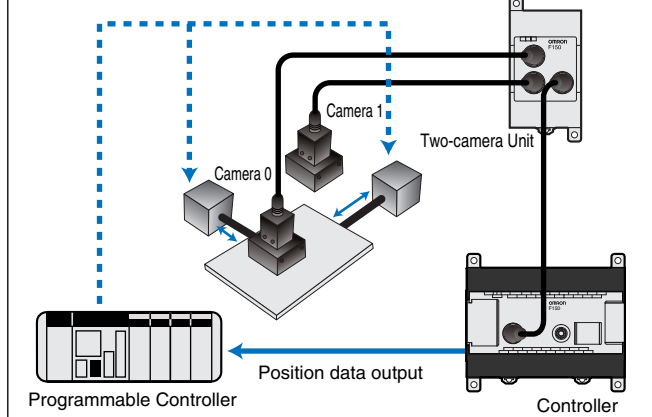

Features

# Image memory function

Up to 23 inspected images can be stored\*.

You can check the image to see what kind of defect occurred. This serves as an aid to maintaining and improving the production line.

With respect to a stored image, measurement can be repeated and measurement conditions changed. This enables a dramatic reduction in setup time during initial installation.

\*Can be stored before power is turned off. Storage of all images, including "good" images, is also possible.

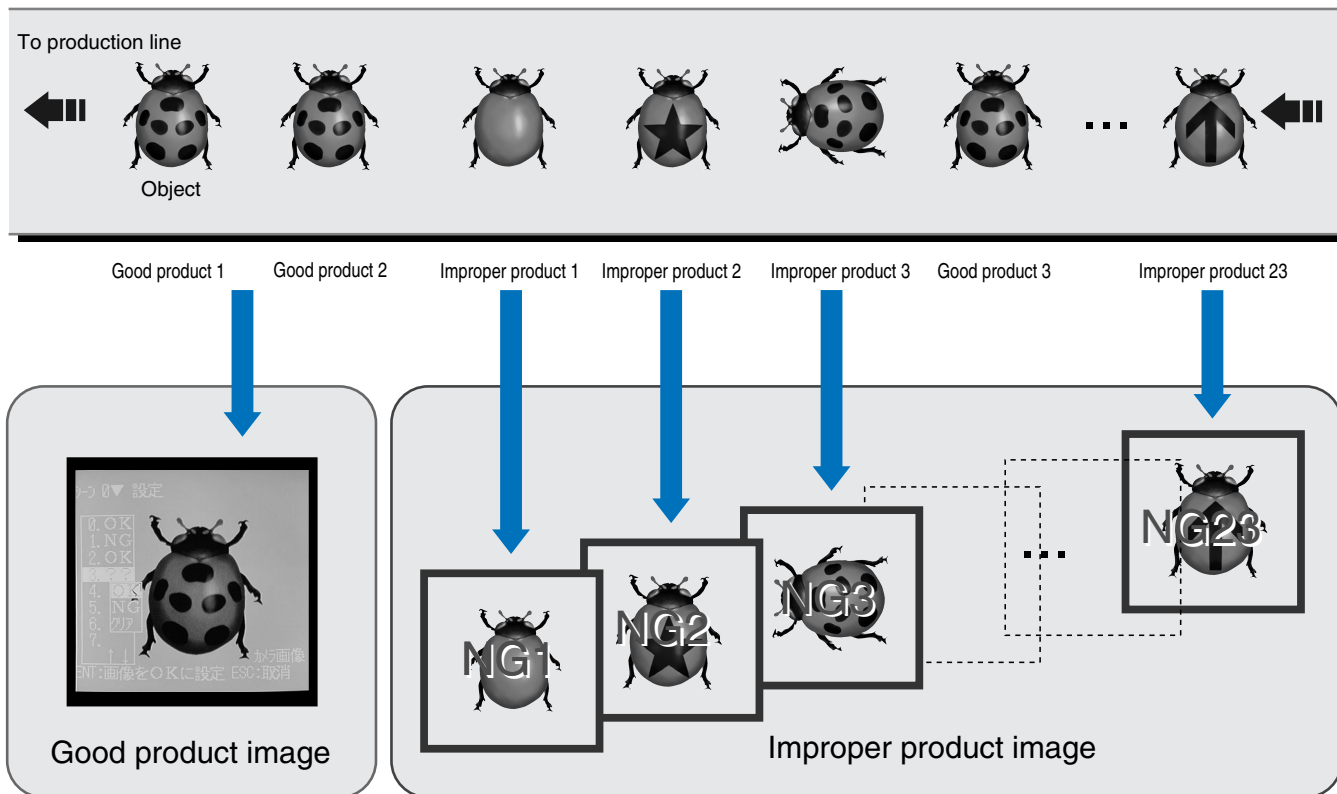

F150-3

Features

Compact frame shutter camera

- Compact with high resolution.
- An all-pixel reading method and square lattice CCD make it possible to obtain a clear and detailed image suitable for image processing.
- Equipped with an electronic shutter to handle high-speed lines.
- The shutter speed can be adjusted for each scene from the menu. Select the optimum shutter speed for the line speed and work.



Image pre-processing

- Pre-processing such as smoothing, edge enhancement, edge extraction, and background cut-off allow you to obtain the optimum image for the inspection.
- Pre-processing can be performed in real time (simultaneously with image read-in).

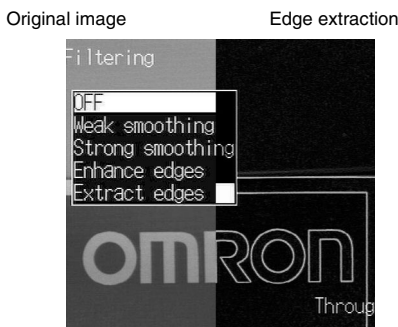

High-precision gray search

- Position measurement at sub-pixel precision is possible using 256 graduation gray search processing. This feature is ideal for high-precision positioning applications.

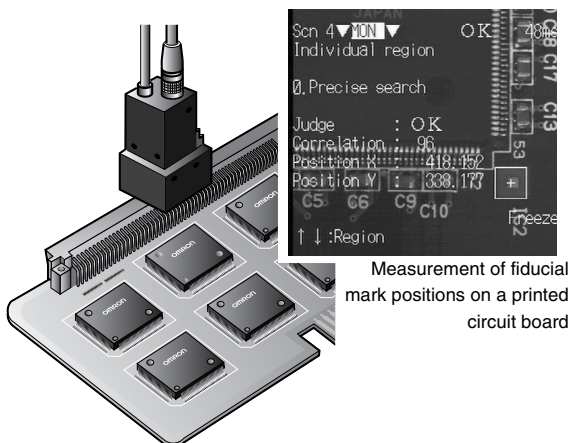

Damage/dirt inspection

- Omron's proprietary algorithm enables fast and detailed inspection for visual defects such as chips, nicks, burrs, and dirt.
- Linear, circular and rectangular areas can be set, enabling inspection for a variety of defect shapes.

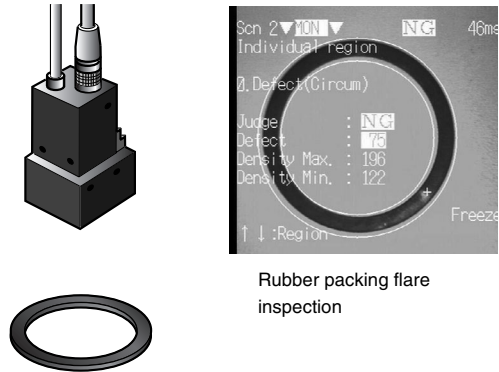

Gray edge measurement

- High-precision (sub-pixel) measurement of work edge position is possible. Ideal for width and dimension inspection.
- Includes edge number and pitch measurement functions for support of IC and connector lead inspection.

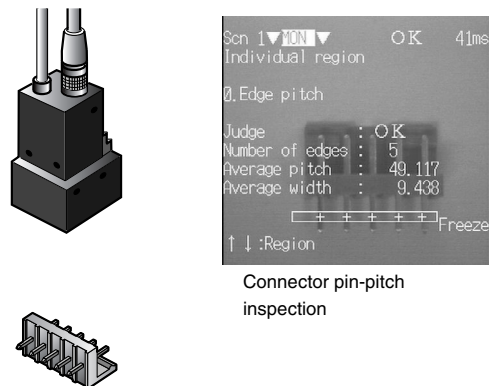

Output computation functions

- Measurement data computations such as the four arithmetical operations, minimum, maximum, distance between two points, and angle can be set from the menu.
- Up to 24 computations can be set, and decision and data output can be performed based on the computation results.

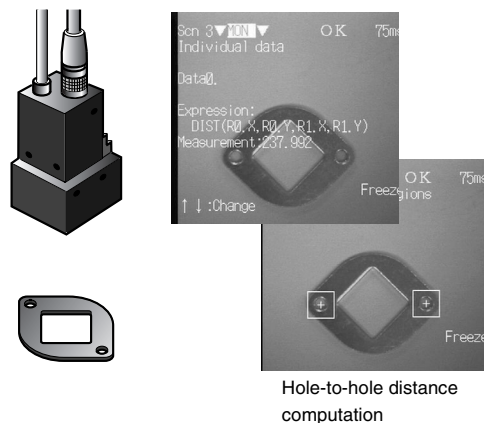

System configuration

Cameras

Camera with Intelligent Light Source:  
F150-SLC20  
(Field of view: 20 mm)



Camera with Intelligent Light Source:  
F150-SLC50  
(Field of view: 50 mm)



Camera with Light Source:  
F150-SL20  
(Field of view: 20 mm)  
F150-SL50  
(Field of view: 50 mm)



F150-S1A  
Camera



When using this camera, please look at "Cameras, lens, and lighting".

\* When the size and view of a measurement item do not suit, please use a general CCTV lens and general lighting.

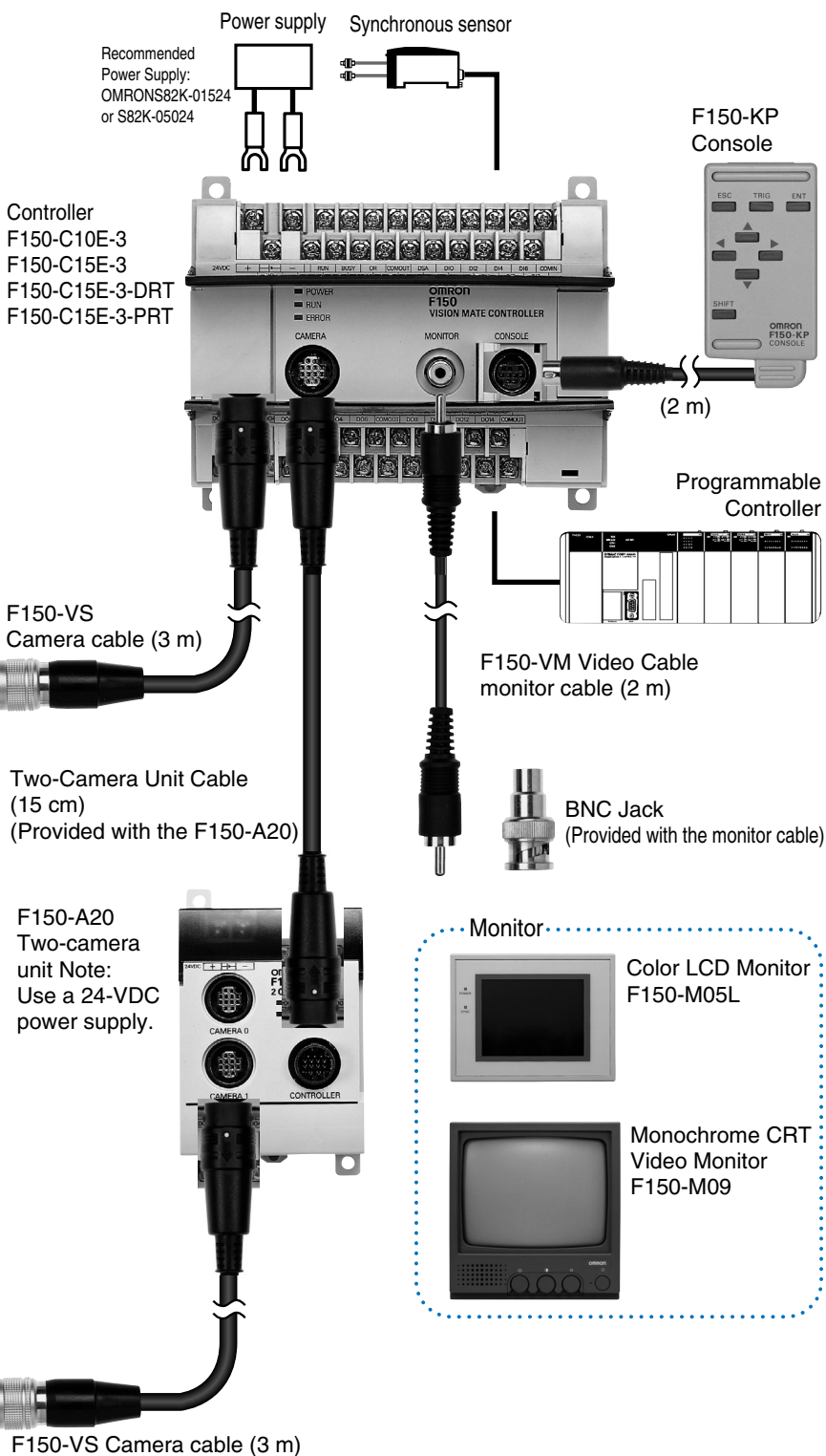

**Monitor**

- Color LCD Monitor F150-M05L
- Monochrome CRT Video Monitor F150-M09

F150-3

## Camera with lighting

### Camera with intelligent lighting

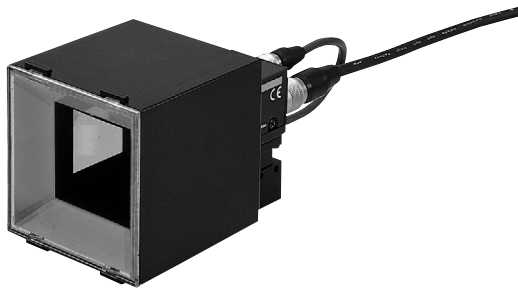

#### Model

Field of view: 20 mm	F150-SLC20
Field of view: 50 mm	F150-SLC50

\*A lens and intelligent lighting are installed on the special camera (F150-S1A) for the F150.

### Camera with lighting



Field of view: 20 mm	F150-SL20A
Field of view: 50 mm	F150-SL50A

\*A lens and lighting are installed on the special camera (F150-S1A) for the F150.

### Distance to inspection object and field of view

The camera distance is fixed.

Fix the camera at a distance that allows correct imaging of the inspected object.

#### F150-SLC20

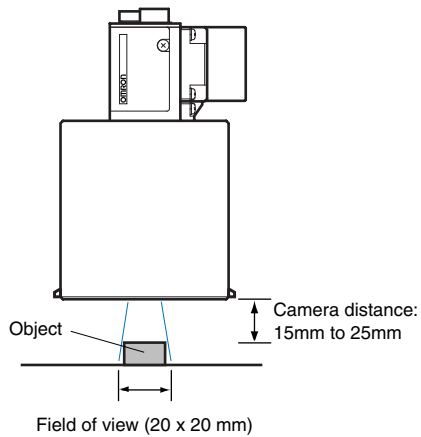

#### F150-SL20A

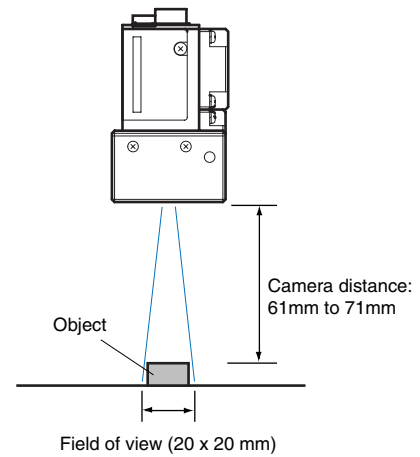

#### F150-SLC50

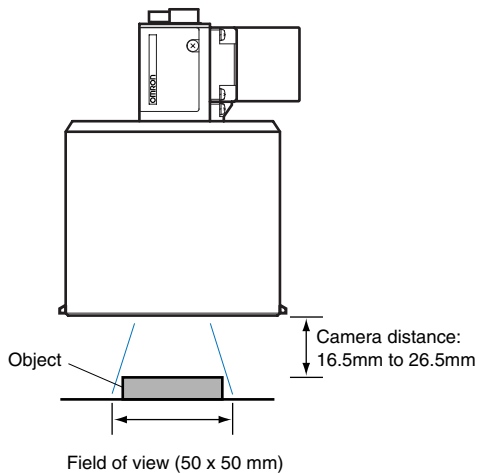

#### F150-SL50A

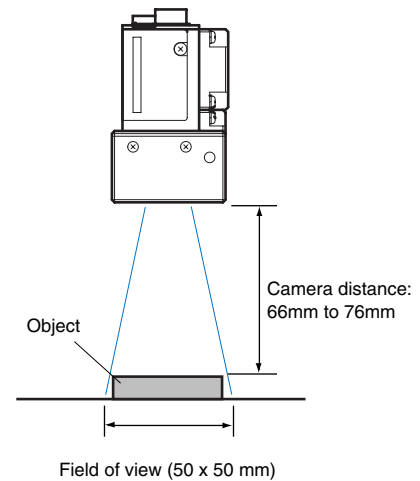

Ordering Information

Name		Model
Controller		F150-C10E-3 (NPN) F150-C15E-3 (PNP)
		F150-C10E-3-DRT (Compo Bus/D) F150-C15E-3-PRT (PROFIBUS)
Camera	Camera with intelligent lighting	F150-SLC20
		F150-SLC50
	Camera with lighting	F150-SL20A
F150-SL50A		
	Camera only	F150-S1A
2-camera unit		F150-A20
Console		F150-KP
LCD monitor		F150-M05L
Video monitor		F150-M09
Camera cable 3 m		F150-VS
Monitor cable 2 m		F150-VM



## Rating/Performance

Controller: F150-C10E-3/C15E-3 and F150-C15E-3-PRT/DRT

Item	Specifications
Number of connected cameras	1 unit / 2 units (using the F150-A20)
Processing resolution	512 (H) x 484 (V)
Number of scenes	16 scenes (can be saved to a computer through the RS-232C)
Image memory function	Up to 23 images can be saved
Processing method	Grey Levels (256) / Binary
Image pre-processing	Smoothing, edge enhancement, edge extraction, background cut-off
Binary Levels	256 levels (per measurement area)
Position correction function	Correction directions: X, Y, Detection modes: binary center of gravity / main axis angle, model position: middle point, edge position
Number of measurement areas	16 areas/scene
Measured data	Area center of gravity, main axis angle, dark-light correlation value, dark-light search position, defect degree, edge position, edge number, density average, relative position
Calculation functions	Four arithmetic operations, distance, maximum value / minimum value, absolute value, others
Result output	Overall decision, computation result (decision) per measurement area, measurement/computation data (RS-232C and parallel output possible)
Monitor	1 ch (supports pin jack and over-scan monitor)
RS-232C	1 ch (Dsub 9-pin, female)
CompoBus/D	1 ch (F150-C10E-3-DRT)
PROFIBUS-DP	1 ch (F150-C15E-3-PRT)
Parallel input/output	F150-C10E-3 and F150-C15E-3: Inputs: 11points, outputs: 21 points F150-C10E-3-PRT/DRT: Inputs: 1 point, outputs: 5 points (including control inputs/outputs)
Power supply voltage	20.4 to 26.4 VDC
Current consumption	Approximately 0.5 A
Ambient temperature	Operating: 0 to +50°C, storage: -25 to +65°C (no ice formation or condensation)
Ambient humidity	Operating/storage: 35 to 85% RH (with no condensation)
Weight (Packed state)	Approximately 940 g (controller: 390 g)
Accessories	Three manuals, CompoBus/D connector (DRT type only), PROFIBUS-DP connector (PRT type only)



Camera

Camera with intelligent lighting: F150-SLC20/50

Camera with lighting: F150-SLC20A/50A

Camera: F150-SL20A/50A

Item		Specifications
Camera	Image pick-up	1/3 inch CCD
	Effective pixels	659(H) x 494(V)
	Shutter function	Electronic frame shutter Shutter speed: 1/100, 1/500, 1/2000, 1/10000 sec (can be changed from the menu)
Lens	Installation distance	F150-SLC20: 15 to 25 mm, F150-SLC50: 16.5 to 26.5 mm, F150-SL20A: 61 to 71 mm, F150-SL50A: 66 to 76 mm
	Field of view	F150-SLC20/SL20A:20 mm <sup>2</sup> , F150-SLC50/SL50A:50 mm <sup>2</sup>
Lighting unit	Light source	F150-SLC20/50: Red LED - green LED mixed F150-SL20A/50A: Red LED
	Light emission method	Pulse emission (synchronized with camera shutter)
Ambient temperature		Operating: 0 to +50°C, storage: -25 to +60°C (no icing or condensation)
Ambient humidity		Operating/storage: 35 to 85% RH (with no condensation)
Weight * Unit only		F150-SLC20: Approximately 280 g F150-SLC50: Approximately 370 g F150-SL20A/50A: Approximately 135 g F150-S1A: Approximately 80 g
Accessories		Instruction manual

F150-3

Two-camera unit: F150-A20

Item	Specifications
Number of connected cameras	2 units
Camera mode	Two-camera switching, vertical division composite, horizontal division composite 1/2, one camera single-stand (camera 0/1)
Supply voltage	20.4 to 26.4 VDC
Current consumption	Approximately 0.3 A
Ambient temperature	Operating: 0 to +50°C, storage: -25 to +65°C (no ice formation or condensation)
Ambient humidity	Operating/storage: 35 to 85% RH (with no condensation)
Weight * Unit only	Approx. 220 g
Accessories	Operation manual, camera unit cable (1)

Note: Can be connected to an F150-C10-3 controller.

Monitor

Item	Product name Model	LCD monitor F150-M05L	Video monitor F150-MON
Size		5.5 type	9 inches
Type		TFT color LCD	CRT monochrome
Resolution		320 x 240 dots	800TV or higher (center)
Input signal		NTSC composite video (1.0 V / 75 Ω)	
Supply voltage		20.4 to 26.4 VDC	100 to 240 VAC (-15%, +10%)
Current consumption		Approx. 700 mA	Approx. 200 mA
Ambient temperature		Operating: 0 to +50°C, storage: -25 to +65°C (no ice formation or condensation)	Operating: -10 to +50°C, storage: -20 to +65°C (no ice formation or condensation)
Ambient humidity		Operating/storage: 35 to 85% RH (no ice formation or condensation)	10 to 90-RH (No condensation)
Weight * Unit only		Approx. 1 kg	Approx. 4.5 kg
Accessories		Operation manual, clamps (4)	Instruction manual

Part Names/Functions

F150-C10E-3/F150-C15E-3

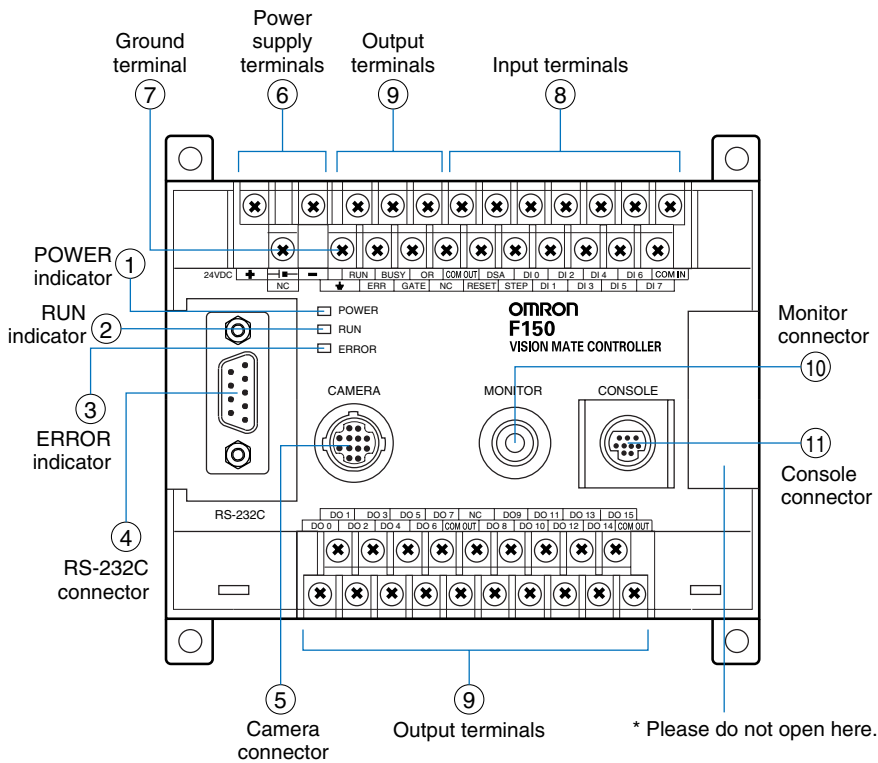

- ① Lit while power is ON.
- ② Lit while the F150 is in Run Mode.
- ③ Lit when an error has occurred.
- ④ Connects the F150 to external devices such as personal computers or programmable controllers.
- ⑤ Connects the F150 to camera or two-camera unit.
- ⑥ Connects to the power supply.
- ⑦ Connects to the ground wire.
- ⑧ ⑨ Connects to the F150 to external devices such as synchronous sensors or programmable controllers.
- ⑩ Connects to the monitor.
- ⑪ Connects to the console.

F150-C10E-3-DRT (CompoBus/D (DeviceNet) type)

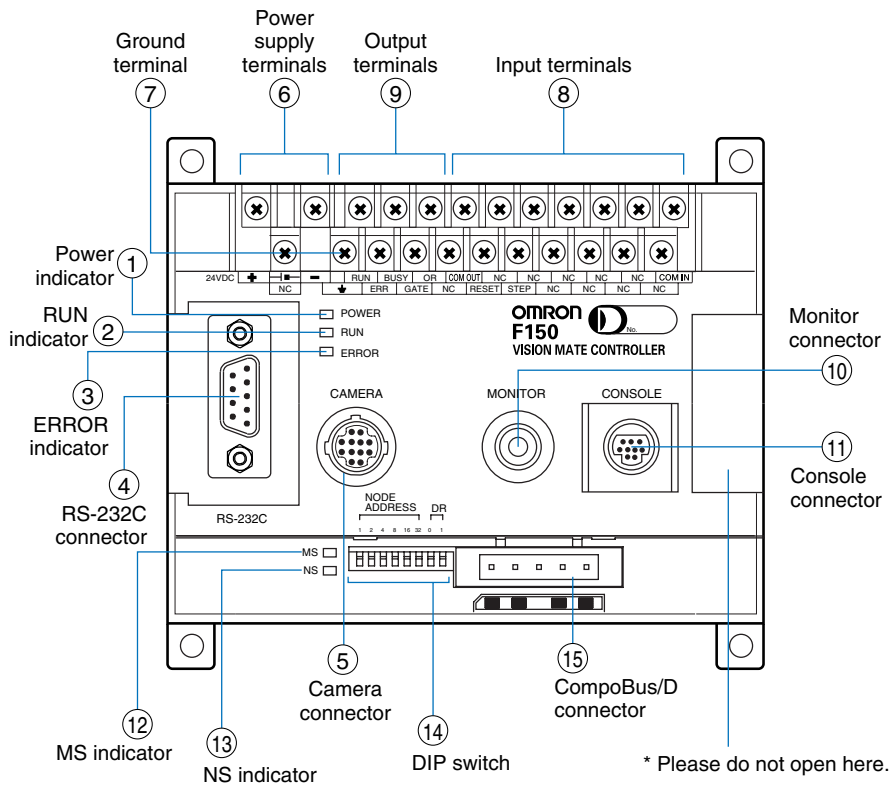

- ① Lit while power is ON.
- ② Lit while the F150 is in Run Mode.
- ③ Lit when an error has occurred.
- ④ Connects the F150 to external devices such as personal computers or programmable controllers.
- ⑤ Connects the F150 to camera or two-camera unit.
- ⑥ Connects to the power supply.
- ⑦ Connects to the ground wire.
- ⑧ ⑨ Connects to the F150 to external devices such as synchronous sensors or programmable controllers.
- ⑩ Connects to the monitor.
- ⑪ Connects to the console.
- ⑫ Indicates the state of F150 in CompoBus/D communication.
- ⑬ Indicates the state of F150 in CompoBus/D communication.
- ⑭ Set up the node address and communication speed of CompoBus/D communication.
- ⑮ Connects to the communication cable of a CompoBus/D network.

F150-C15E-3-PRT (PROFIBUS-DP type)

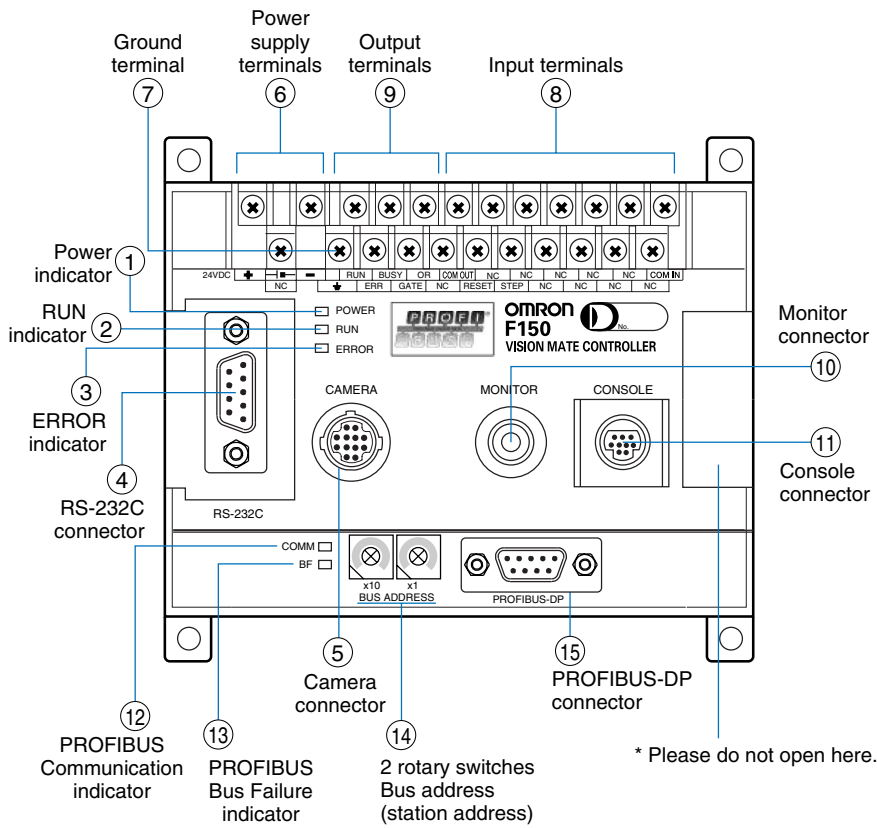

- ① Lit while power is ON.
- ② Lit while the F150 is in Run Mode.
- ③ Lit when an error has occurred.
- ④ Connects the F150 to external devices such as personal computers or programmable controllers.
- ⑤ Connects the F150 to camera or two-camera unit.
- ⑥ Connects to the power supply.
- ⑦ Connects to the ground wire.
- ⑧ ⑨ Connects to the F150 to external devices such as synchronous sensors or programmable controllers.
- ⑩ Connects to the monitor.
- ⑪ Connects to the console.
- ⑫ Indicates the state of F150 in PROFIBUS-DP communication.
- ⑬ Indicates the state of F150 in PROFIBUS-DP communication.
- ⑭ Set up the node address of PROFIBUS-DP communication.
- ⑮ Connects to the communication cable of a PROFIBUS-DP network.

F150-3

Function menu

Menu structure diagram

Dialog menu

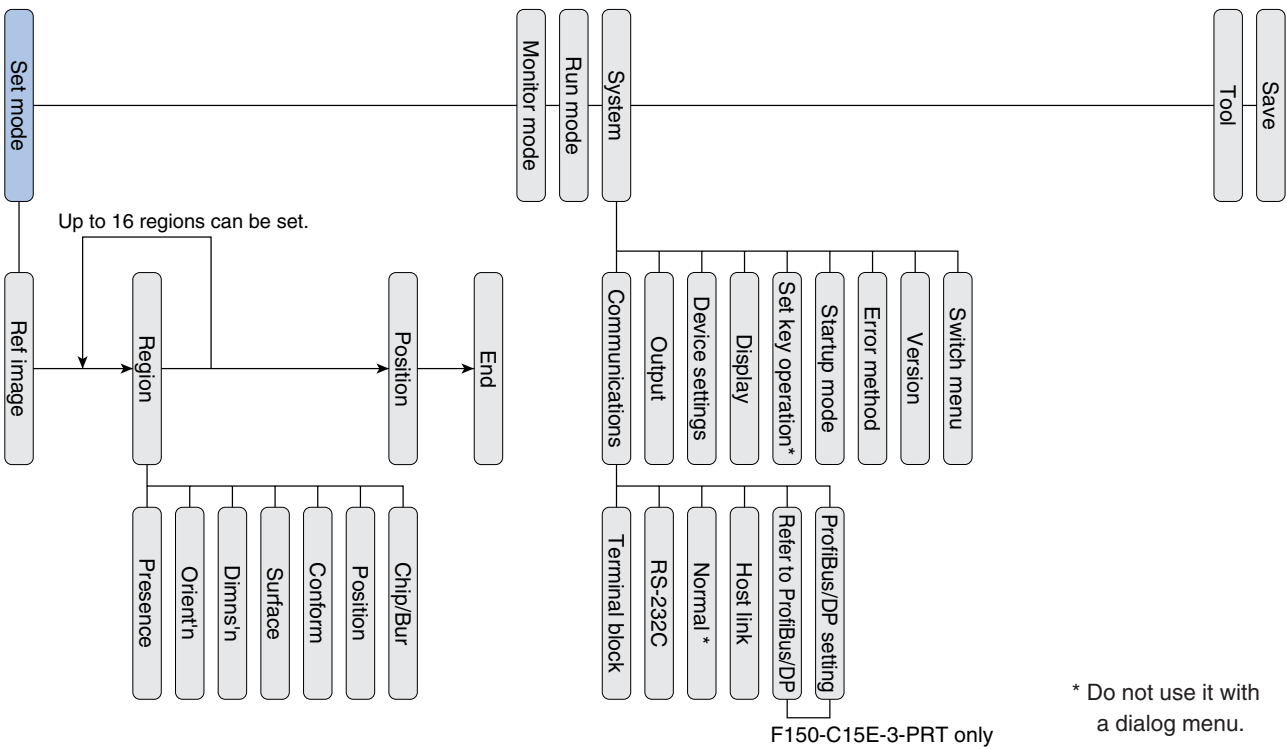

Expert menu

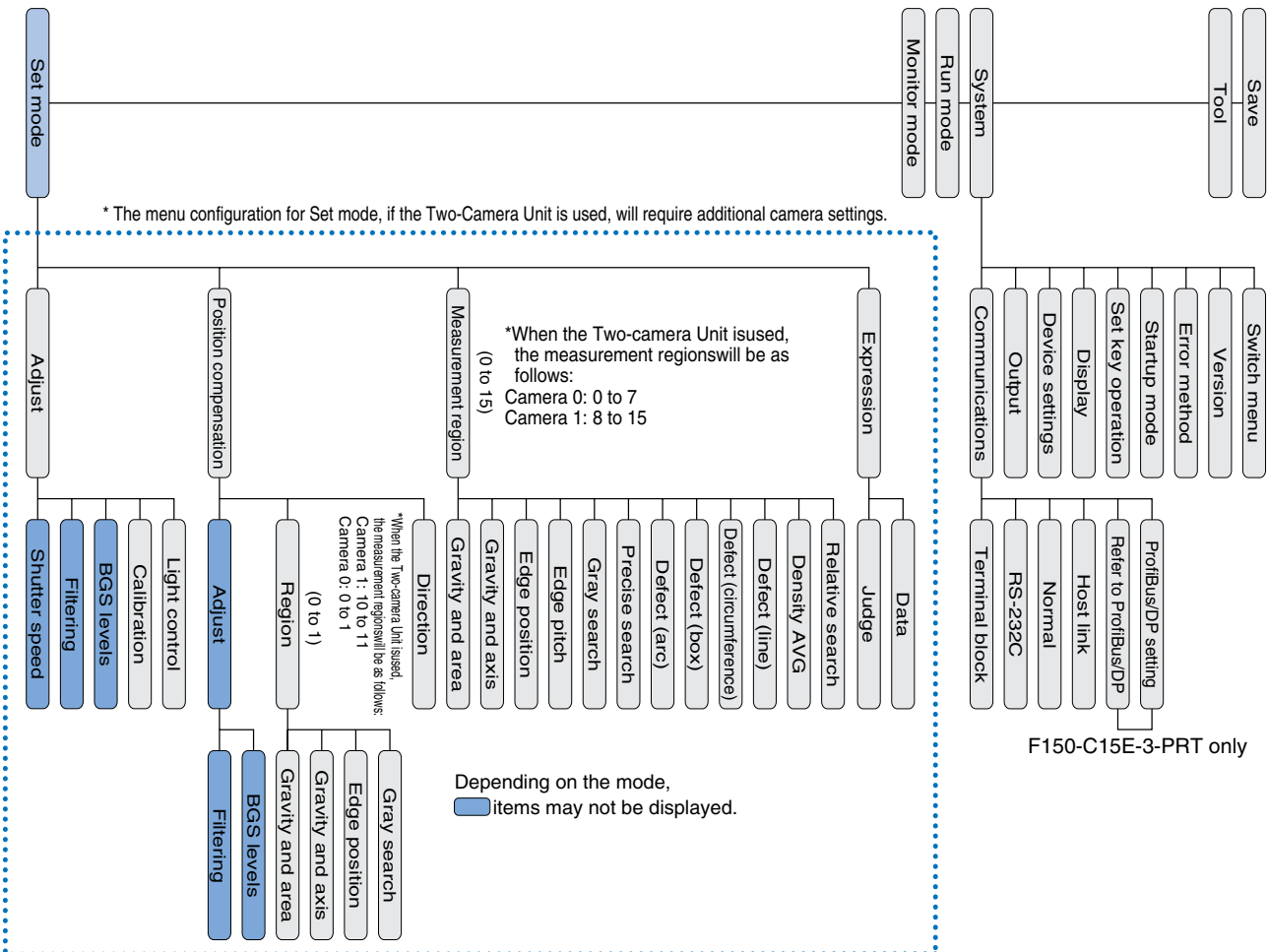

Dimensions (Unit: mm)

Controller

F150-C10E-3, F150-C50E-3,  
F150-C15E-3-PRT,  
F150-C10E-3-DRT

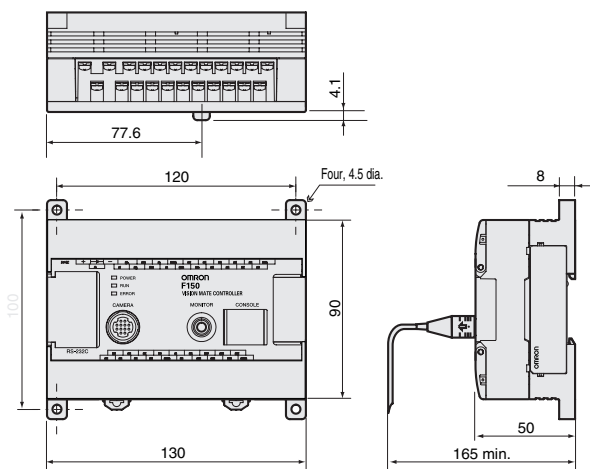

Console

F150-KP

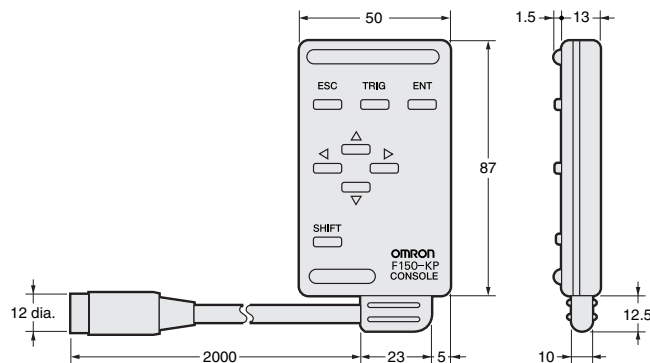

Camera

F150-SLC20 (camera with F150-LTC20 intelligent lighting)

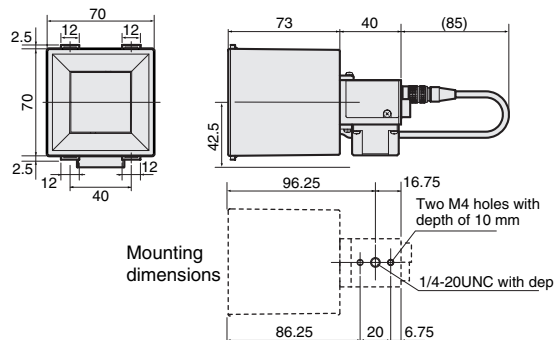

F150-SL20A/SL50A (camera with lighting)

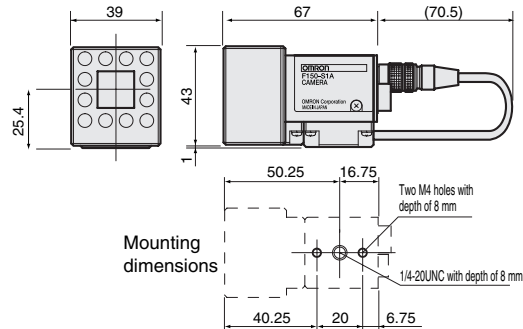

F150-SLC50 (camera with F150-LTC50 intelligent lighting)

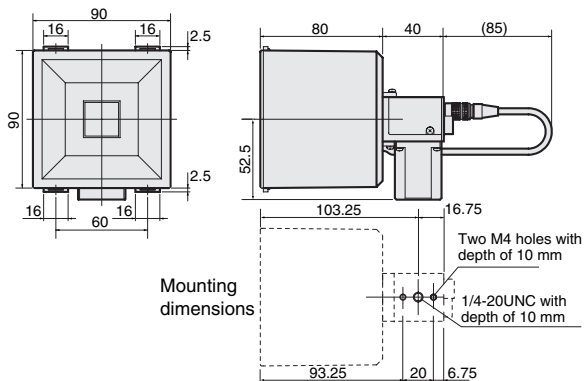

F150-S1A (camera only)

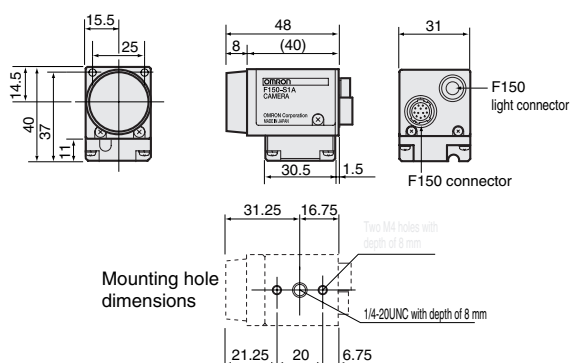

2-camera unit

F150-A20

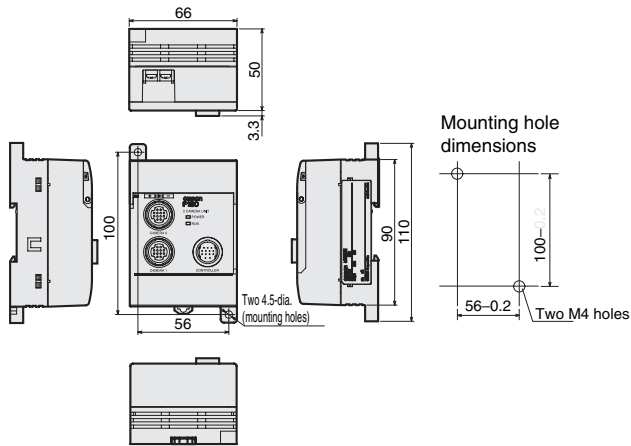

LCD monitor

F150-M05L

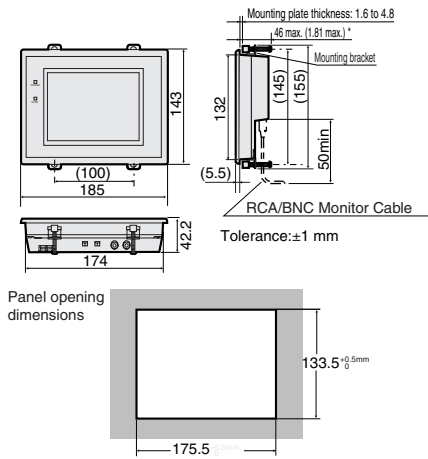

CRT monitor

F150-M09

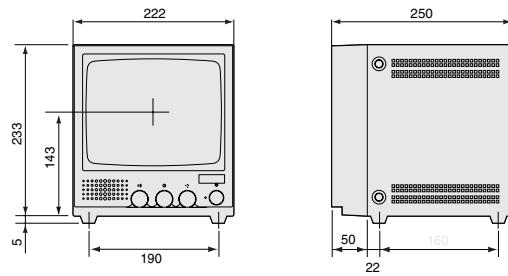

ALL DIMENSIONS SHOWN ARE IN MILLIMETERS.  
 To convert millimeters into inches, multiply by 0.03937. To convert grams into ounces, multiply by 0.03527.