

**DRT2 Series**

**DeviceNet Slaves**

# **OPERATION MANUAL**

**OMRON**

# **DRT2 Series DeviceNet Slaves**

## **Operation Manual**

*Revised April 2008*





## **Notice:**

OMRON products are manufactured for use according to proper procedures by a qualified operator and only for the purposes described in this manual.

The following conventions are used to indicate and classify precautions in this manual. Always heed the information provided with them. Failure to heed precautions can result in injury to people or damage to property.

 **DANGER** Indicates an imminently hazardous situation which, if not avoided, will result in death or serious injury. Additionally, there may be severe property damage.

 **WARNING** Indicates a potentially hazardous situation which, if not avoided, could result in death or serious injury. Additionally, there may be severe property damage.

 **Caution** Indicates a potentially hazardous situation which, if not avoided, may result in minor or moderate injury, or property damage.

## **OMRON Product References**

All OMRON products are capitalized in this manual. The word “Unit” is also capitalized when it refers to an OMRON product, regardless of whether or not it appears in the proper name of the product.

The abbreviation “Ch,” which appears in some displays and on some OMRON products, often means “word” and is abbreviated “Wd” in documentation in this sense.

The abbreviation “PLC” means Programmable Controller. “PC” is used, however, in some Programming Device displays to mean Programmable Controller.

## **Visual Aids**

The following headings appear in the left column of the manual to help you locate different types of information.

**Note** Indicates information of particular interest for efficient and convenient operation of the product.

**1,2,3...** 1. Indicates lists of one sort or another, such as procedures, checklists, etc.

### **© OMRON, 2002**

All rights reserved. No part of this publication may be reproduced, stored in a retrieval system, or transmitted, in any form, or by any means, mechanical, electronic, photocopying, recording, or otherwise, without the prior written permission of OMRON.

No patent liability is assumed with respect to the use of the information contained herein. Moreover, because OMRON is constantly striving to improve its high-quality products, the information contained in this manual is subject to change without notice. Every precaution has been taken in the preparation of this manual. Nevertheless, OMRON assumes no responsibility for errors or omissions. Neither is any liability assumed for damages resulting from the use of the information contained in this publication.





# TABLE OF CONTENTS

<b>PRECAUTIONS</b> .....	<b>xv</b>
1 Intended Audience .....	xvi
2 General Precautions .....	xvii
3 Safety Precautions .....	xviii
4 Operating Environment Precautions .....	xix
5 Application Precautions .....	xx
6 Conformance to EC Directives .....	xxii
<b>SECTION 1</b>	
<b>Smart Slaves and Features</b> .....	<b>1</b>
1-1 DRT2 Features .....	2
1-2 DRT2 Slaves .....	7
<b>SECTION 2</b>	
<b>Example System Startup</b> .....	<b>21</b>
2-1 Basic Procedures and Configuration Examples .....	22
2-2 Preparations .....	23
2-3 Setting and Wiring Hardware .....	24
2-4 Starting Communications .....	27
2-5 Checking Operation .....	29
<b>SECTION 3</b>	
<b>Common Slave Specifications</b> .....	<b>31</b>
3-1 Common Slave Specifications .....	32
3-2 DeviceNet Remote I/O Communications .....	34
<b>SECTION 4</b>	
<b>Functions of All Slaves, General-purpose Slaves, and Environment-resistive Slaves</b> .....	<b>47</b>
4-1 Maintenance Mode Window and Main Window .....	48
4-2 Common Slave Functions .....	52
4-3 Functions of General-purpose Slaves and Environment-resistive Slaves .....	61
<b>SECTION 5</b>	
<b>General-purpose Slaves</b> .....	<b>83</b>
5-1 Common Specifications for General-purpose Slaves .....	85
5-2 Connecting Communications Cables to General-purpose Slaves .....	87
5-3 Mounting Terminating Resistors .....	91
5-4 Maintenance Information Window .....	91
5-5 Remote I/O Terminals with Transistors .....	97
5-6 Connector Terminals with Transistors .....	144
5-7 Screw-less Clamp Terminals .....	203

# TABLE OF CONTENTS

## SECTION 6

<b>Environment-resistive Slaves</b> .....	<b>233</b>
6-1 Common Specifications for Environment-resistive Slaves .....	234
6-2 Connecting Communications Cables to Environment-resistive Slaves .....	236
6-3 Maintenance Information Window .....	239
6-4 Advanced Environment-resistive Terminals .....	245
6-5 Standard Environment-resistive Terminals .....	260
6-6 Mounting and Wiring Environment-resistive Slaves .....	286

## SECTION 7

<b>Analog Slaves</b> .....	<b>291</b>
7-1 Overview of Analog Slaves .....	292
7-2 Common Procedures .....	308
7-3 Maintenance Information Window .....	310
7-4 Analog Input Terminals .....	315
7-5 Analog Output Terminals .....	359
7-6 Temperature Input Terminals .....	377

## SECTION 8

<b>Communications Timing</b> .....	<b>443</b>
8-1 Remote I/O Communications Characteristics .....	444
8-2 Message Communications Characteristics .....	453

## SECTION 9

<b>Troubleshooting and Maintenance</b> .....	<b>455</b>
9-1 Indicators and Error Processing .....	456
9-2 Troubleshooting .....	457
9-3 Maintenance .....	466

## Appendices

A DeviceNet Explicit Messages .....	469
B Using Another Company's Master Unit .....	493
C Restrictions on Reading Total ON Time/Contact Operation Counter for All Slaves at Once .....	539
D Connectable Devices .....	553
E Current Consumption Summary .....	563
F Precautions with Connecting Two-wire DC Sensors .....	567

<b>Index</b> .....	<b>569</b>
--------------------	------------

<b>Revision History</b> .....	<b>575</b>
-------------------------------	------------

## About this Manual:

This manual describes the installation and operation of an DeviceNet Smart Slave Units and includes the sections described below.

Please read this manual carefully and be sure you understand the information provided before attempting to install or operate the DeviceNet Smart Slave Units. **Be sure to read the precautions provided in the following section.**

The following manuals also cover information related to DeviceNet applications. Use the *DeviceNet Operation Manual* together with other required manuals.

Manual	Contents	Cat. No.
DeviceNet Operation Manual	Describes the configuration and construction of a DeviceNet network, including installation procedures and specifications for cables, connectors, and other connection devices, as well as information on functions, operating procedures, and applications.	W267
DeviceNet Masters Operation Manual	Describes the models, specifications, functions, operating procedures, and applications of C200HX/HG/HE, CVM1, and CV-series DeviceNet Master Units.	W379
DeviceNet CS/CJ Series Units Operation Manual	Describes the models, specifications, functions, operating procedures, and applications of CS-series and CJ-series DeviceNet Master Units.	W380
DeviceNet DRT2 Series Slaves Operation Manual (this manual)	Describes the models, specifications, functions, operating procedures, and applications of DRT2-series Smart Slave Units.	W404
DeviceNet DRT1 Series Slaves Operation Manual	Describes the models, specifications, functions, operating procedures, and applications of DRT1-series Smart Slave Units.	W347
DeviceNet Configurator Ver. 2.□ Operation Manual	Describes the operating procedures of the DeviceNet Configurator.	W382
DeviceNet MULTIPLE I/O TERMINAL Operation Manual	Describes the models, specifications, functions, operating procedures, and applications of the DeviceNet MULTIPLE I/O TERMINALS.	W348

**Precautions** provides general precautions for planning, installing, and operating the DeviceNet DRT2-series Smart Slaves and related devices.

**Section 1** provides an overview of the DeviceNet DRT2-series Smart Slaves, including lists of models, and information on features that were not included in the DRT1-series Slaves.

**Section 2** provides information on hardware aspects of Masters and Slaves connected to a DeviceNet Network to ensure the proper operation of the system. Included are system configuration examples, basic procedures for wiring, details on mounting and setting Master and Slave Units, procedures for connecting cables and power supplies, creating I/O tables, creating and registering scan lists, and checking operation of the system.

**Section 3** provides specifications and indicator displays that are common to all Slaves. The allocation of remote I/O memory for Smart Slaves is also described here.

**Section 4** describes the functions of DRT2-series Smart Slaves and their applications, including operation procedures using a DeviceNet Configurator.

**Section 5** provides the specifications and describes the components, terminal arrangements, basic procedures for wiring, and methods for connecting cables of General-purpose Slaves. Information on Slave settings, mounting and wiring methods are also provided separately for each Slave type.

**Section 6** provides the specifications and describes the components, terminal arrangements, basic procedures for wiring, and methods for connecting cables of Environment-resistive Slaves (conforming to IP67). Information on Slave settings, mounting and wiring methods are also provided separately for each Slave type.

## About this Manual, Continued

**Section 7** provides the specifications, terminal arrangements, mounting procedures, and connection methods of Analog I/O Terminals. Information is included on types of I/O data that can be allocated, allocation methods and procedures, and math operation processing. Setting methods using the Configurator are also described.

**Section 8** provides information on the time required for a complete communications cycle, for an output response to be made to an input, to start the system, and to send messages.

**Section 9** describes error processing, periodic maintenance operations, and troubleshooting procedures needed to keep the DeviceNet Network operating properly. We recommend reading through the error processing procedures in both this manual and the operation manual for the master being used before operation so that operating errors can be identified and corrected more quickly.

**Appendix A** provides lists of DeviceNet explicit messages and their basic format.

**Appendix B** provides information on using masters from other companies and Slave device profiles necessary for multi-vendor applications, including information on installing EDS files.

**Appendix C** describes restrictions on reading the total ON time and contact operation counter for all Slaves at once.

**Appendix D** provides lists of standard models of DRT2-series Smart Slaves and connectable devices.

**Appendix E** shows the current consumptions of DRT2-series Smart Slaves.

**Appendix F** provides precautions for connecting two-wire DC sensors.



**WARNING** Failure to read and understand the information provided in this manual may result in personal injury or death, damage to the product, or product failure. Please read each section in its entirety and be sure you understand the information provided in the section and related sections before attempting any of the procedures or operations given.

## ***Read and Understand this Manual***

Please read and understand this manual before using the product. Please consult your OMRON representative if you have any questions or comments.

## ***Warranty and Limitations of Liability***

### ***WARRANTY***

OMRON's exclusive warranty is that the products are free from defects in materials and workmanship for a period of one year (or other period if specified) from date of sale by OMRON.

OMRON MAKES NO WARRANTY OR REPRESENTATION, EXPRESS OR IMPLIED, REGARDING NON-INFRINGEMENT, MERCHANTABILITY, OR FITNESS FOR PARTICULAR PURPOSE OF THE PRODUCTS. ANY BUYER OR USER ACKNOWLEDGES THAT THE BUYER OR USER ALONE HAS DETERMINED THAT THE PRODUCTS WILL SUITABLY MEET THE REQUIREMENTS OF THEIR INTENDED USE. OMRON DISCLAIMS ALL OTHER WARRANTIES, EXPRESS OR IMPLIED.

### ***LIMITATIONS OF LIABILITY***

OMRON SHALL NOT BE RESPONSIBLE FOR SPECIAL, INDIRECT, OR CONSEQUENTIAL DAMAGES, LOSS OF PROFITS OR COMMERCIAL LOSS IN ANY WAY CONNECTED WITH THE PRODUCTS, WHETHER SUCH CLAIM IS BASED ON CONTRACT, WARRANTY, NEGLIGENCE, OR STRICT LIABILITY.

In no event shall the responsibility of OMRON for any act exceed the individual price of the product on which liability is asserted.

IN NO EVENT SHALL OMRON BE RESPONSIBLE FOR WARRANTY, REPAIR, OR OTHER CLAIMS REGARDING THE PRODUCTS UNLESS OMRON'S ANALYSIS CONFIRMS THAT THE PRODUCTS WERE PROPERLY HANDLED, STORED, INSTALLED, AND MAINTAINED AND NOT SUBJECT TO CONTAMINATION, ABUSE, MISUSE, OR INAPPROPRIATE MODIFICATION OR REPAIR.

# ***Application Considerations***

## ***SUITABILITY FOR USE***

OMRON shall not be responsible for conformity with any standards, codes, or regulations that apply to the combination of products in the customer's application or use of the products.

At the customer's request, OMRON will provide applicable third party certification documents identifying ratings and limitations of use that apply to the products. This information by itself is not sufficient for a complete determination of the suitability of the products in combination with the end product, machine, system, or other application or use.

The following are some examples of applications for which particular attention must be given. This is not intended to be an exhaustive list of all possible uses of the products, nor is it intended to imply that the uses listed may be suitable for the products:

- Outdoor use, uses involving potential chemical contamination or electrical interference, or conditions or uses not described in this manual.
- Nuclear energy control systems, combustion systems, railroad systems, aviation systems, medical equipment, amusement machines, vehicles, safety equipment, and installations subject to separate industry or government regulations.
- Systems, machines, and equipment that could present a risk to life or property.

Please know and observe all prohibitions of use applicable to the products.

**NEVER USE THE PRODUCTS FOR AN APPLICATION INVOLVING SERIOUS RISK TO LIFE OR PROPERTY WITHOUT ENSURING THAT THE SYSTEM AS A WHOLE HAS BEEN DESIGNED TO ADDRESS THE RISKS, AND THAT THE OMRON PRODUCTS ARE PROPERLY RATED AND INSTALLED FOR THE INTENDED USE WITHIN THE OVERALL EQUIPMENT OR SYSTEM.**

## ***PROGRAMMABLE PRODUCTS***

OMRON shall not be responsible for the user's programming of a programmable product, or any consequence thereof.

## **Disclaimers**

### ***CHANGE IN SPECIFICATIONS***

Product specifications and accessories may be changed at any time based on improvements and other reasons.

It is our practice to change model numbers when published ratings or features are changed, or when significant construction changes are made. However, some specifications of the products may be changed without any notice. When in doubt, special model numbers may be assigned to fix or establish key specifications for your application on your request. Please consult with your OMRON representative at any time to confirm actual specifications of purchased products.

### ***DIMENSIONS AND WEIGHTS***

Dimensions and weights are nominal and are not to be used for manufacturing purposes, even when tolerances are shown.

### ***PERFORMANCE DATA***

Performance data given in this manual is provided as a guide for the user in determining suitability and does not constitute a warranty. It may represent the result of OMRON's test conditions, and the users must correlate it to actual application requirements. Actual performance is subject to the OMRON Warranty and Limitations of Liability.

### ***ERRORS AND OMISSIONS***

The information in this manual has been carefully checked and is believed to be accurate; however, no responsibility is assumed for clerical, typographical, or proofreading errors, or omissions.





# PRECAUTIONS

This section provides general precautions for installing and using the DeviceNet Smart Slave and related devices.

**The information contained in this section is important for the safe and reliable application of the DeviceNet Smart Slave. You must read this section and understand the information contained before attempting to set up or operate a DeviceNet network using DeviceNet Smart Slaves.**

1	Intended Audience .....	xvi
2	General Precautions .....	xvii
3	Safety Precautions .....	xviii
4	Operating Environment Precautions .....	xix
5	Application Precautions .....	xx
6	Conformance to EC Directives .....	xxii
6-1	Applicable Directives .....	xxii
6-2	Concepts .....	xxii
6-3	Conformance to EC Directives .....	xxii

# 1 Intended Audience

This manual is intended for the following personnel, who must also have knowledge of electrical systems (an electrical engineer or the equivalent).

- Personnel in charge of purchasing FA systems.
- Personnel in charge of designing FA systems.
- Personnel in charge of installing and connecting FA systems.
- Personnel in charge of managing FA systems and facilities.

## 2 General Precautions

The user must operate the product according to the specifications described in the operation manuals.

Before using the product under conditions which are not described in the manual or applying the product to nuclear control systems, railroad systems, aviation systems, vehicles, combustion systems, medical equipment, amusement machines, safety equipment, and other systems, machines, and equipment that may have a serious influence on lives and property if used improperly, consult your OMRON representative.

Make sure that the ratings and performance characteristics of the product are sufficient for the systems, machines, and equipment, and be sure to provide the systems, machines, and equipment with redundant safety mechanisms.

This manual provides information for installing and operating OMRON DeviceNet products. Be sure to read this manual before operation and keep this manual close at hand for reference during operation.

 **WARNING** It is extremely important that a PLC and all PLC Units be used for the specified purpose and under the specified conditions, especially in applications that can directly or indirectly affect human life. You must consult with your OMRON representative before applying a PLC system to the above mentioned applications.

## 3 Safety Precautions

 **WARNING** Never attempt to disassemble any Units while power is being supplied. Doing so may result in serious electrical shock or electrocution.

 **WARNING** Provide safety measures in external circuits (i.e., not in the Programmable Controller), including the following items, to ensure safety in the system if an abnormality occurs due to malfunction of the PLC or another external factor affecting the PLC operation. Not doing so may result in serious accidents.

 **WARNING** Input only the specified range of voltage or current to a Unit. A current or voltage exceeding the specified range may cause malfunction or fire.

 **WARNING** Provide safety measures in external circuits (i.e., not in the Programmable Controller), including the following items, to ensure safety in the system if an abnormality occurs due to malfunction of the PLC or another external factor affecting the PLC operation. Not doing so may result in serious accidents.

- Emergency stop circuits, interlock circuits, limit circuits, and similar safety measures must be provided in external control circuits.
- The PLC will turn OFF all outputs when its self-diagnosis function detects any error or when a severe failure alarm (FALS) instruction is executed. As a countermeasure for such errors, external safety measures must be provided to ensure safety in the system.
- The PLC outputs may remain ON or OFF due to deposits on or burning of the output relays, or destruction of the output transistors. As a countermeasure for such problems, external safety measures must be provided to ensure safety in the system.
- When the 24-V DC output (service power supply to the PLC) is overloaded or short-circuited, the voltage may drop and result in the outputs being turned OFF. As a countermeasure for such problems, external safety measures must be provided to ensure safety in the system.

 **WARNING** The CPU Unit refreshes I/O even when the program is stopped (i.e., even in PROGRAM mode). Confirm safety thoroughly in advance before changing the status of any part of memory allocated to Output Units, Special I/O Units, or CPU Bus Units. Any changes to the data allocated to any Unit may result in unexpected operation of the loads connected to the Unit. Any of the following operations may result in changes to memory status.

- Transferring I/O memory data to the CPU Unit from a Programming Device
- Changing present values in memory from a Programming Device
- Force-setting/-resetting bits from a Programming Device
- Transferring I/O memory files from a Memory Card or EM file memory to the CPU Unit
- Transferring I/O memory from a host computer or from another PLC on a network

## 4 Operating Environment Precautions

Install the system properly according to the directions in this manual.

Do not operate the control system in the following places.

- Locations subject to direct sunlight.
- Locations subject to temperatures or humidity outside the range specified in the specifications.
- Locations subject to condensation as the result of severe changes in temperature.
- Locations subject to corrosive or flammable gases.
- Locations subject to dust (especially iron dust) or salts.
- Locations subject to water, oil, or chemicals (General-purpose Slaves)
- Locations subject to acid or chemicals (Environment-resistive Slaves).
- Locations subject to shock or vibration.

Take appropriate and sufficient countermeasures when installing systems in the following locations:

- Locations subject to static electricity or other forms of noise.
- Locations subject to strong electromagnetic fields.
- Locations subject to possible exposure to radioactivity.
- Locations close to power supplies.

 **Caution** The operating environment of the PLC System can have a large effect on the longevity and reliability of the system. Improper operating environments can lead to malfunction, failure, and other unforeseeable problems with the PLC System. Be sure that the operating environment is within the specified conditions at installation and remains within the specified conditions during the life of the system.

## 5 Application Precautions

Observe the following precautions when using the DeviceNet Smart Slave.

- Fail-safe measures must be taken by the customer to ensure safety in the event of incorrect, missing, or abnormal signals caused by broken signal lines, momentary power interruptions, or other causes.
- Provide external interlock circuits, limit circuits, and other safety circuits in addition to any provided within the PLC to ensure safety.
- Mount the Unit to a DIN Track or mount it with screws.
- If the system is installed at a site with poor power supply conditions, take appropriate measures to ensure that the power supply remains within the rated voltage and frequency specifications.
- Provide circuit breakers and other safety measures to provide protection against shorts in external wiring.
- Always ground the system to 100  $\Omega$  or less when installing the system to protect against electrical shock.
- Always turn OFF the communications power supply and the power supplies to the PLC and Slaves before attempting any of the following.
  - Mounting or removing a Unit such as an I/O Unit, CPU Unit, Memory Cassette, or Master Unit.
  - Mounting or removing Remote I/O Terminal circuit sections.
  - Assembling any devices or racks.
  - Setting rotary switches.
  - Connecting or wiring cables.
  - Connecting or disconnecting connectors.
- Do not attempt to disassemble, repair, or modify any Units.
- Be sure that all the terminal screws are tightened to the torque specified in the relevant manuals. Loose screws may cause fire, malfunction, or damage the Unit.
- Be sure that all the mounting screws and cable connector screws are tightened to the torque specified in the relevant manuals.
- Do not remove the label from a Unit before wiring. Always remove the label after completing wiring, however, to ensure proper heat dispersion.
- Use crimp terminals for wiring. Do not connect bare stranded wires directly to terminals.
- Double-check all switch settings and wiring before turning ON the power supply.
- Always follow the electrical specifications for terminal polarity, communications path wiring, power supply wiring, and I/O jumpers. Incorrect wiring can cause failures.
- Be sure to wire the Unit correctly.
- Be sure to wire terminals with the correct polarity.
- Be sure that the communications cable connectors and other items with locking devices are properly locked into place.
- Do not drop the Unit or subject the Unit to excessive vibration or shock. Doing so may cause malfunction or damage to the Unit.
- Use the special packing box when transporting the Unit. Ensure that the product is handled carefully so that no excessive vibration or impact is applied to the product during transportation.

- Do not apply voltages or connect loads to the Output Units in excess of the maximum switching capacity.
- Do not apply voltages to the Input Units in excess of the rated value.
- After replacing a CPU Unit or Special I/O Unit, resume operation only after transferring to the new CPU Unit or Special I/O Unit the contents of the DM Area, HR Area, and other data required for resuming operation.
- Check the user program for proper execution before actually running it with the system.
- Observe the following precautions when wiring the communications cables.
  - Wire the communications cables separately from the power lines or high-tension lines.
  - Do not bend the communications cables excessively.
  - Do not pull on the communications cables excessively.
  - Do not place objects on top of the communications cables.
  - Route communications cables inside ducts.
- Confirm that the system will not be adversely affected before performing the following operations.
  - Changing the operating mode of the PLC
  - Setting/resetting any bit in memory
  - Changing the present value of any word or any set value in memory
- Before touching a Unit, be sure to first touch a grounded metallic object in order to discharge any static build-up.
- When replacing parts, such as a relay, make sure the replacement part has the correct specifications.
- Be sure that metal filings do not enter the Unit when wiring or installing.
- Use correct parts for wiring.
- Use the specified communications cables and connectors.
- Always enable the scan list before operation.
- Before clearing the scan list of a Unit that has user-allocated remote I/O, always confirm that no errors occur after the I/O Area setting is changed to fixed allocation.
- When adding a new node to the network, check that the new node's baud rate is the same as the baud rate set on the other nodes.
- Do not extend connection distances beyond the ranges given in the specifications.
- Although the Environment-resistive Slaves have IP67 enclosure ratings, do not use them in applications where the Slave is always submerged in water.



## 6 Conformance to EC Directives

### 6-1 Applicable Directives

- EMC Directives
- Low Voltage Directive

### 6-2 Concepts

#### **EMC Directives**

OMRON devices are designed so that they comply with the related EMC Directives so that they can be more easily built into other devices or the overall machine. The actual products have been checked for conformity to EMC Directives (see the following note). Whether the products conform to the standards in the system used by the customer, however, must be checked by the customer.

EMC-related performance of the OMRON devices that comply with EC Directives will vary depending on the configuration, wiring, and other conditions of the equipment or control panel on which the OMRON devices are installed. The customer must, therefore, perform the final check to confirm that devices and the overall machine conform to EMC standards.

**Note** Applicable EMC (Electromagnetic Compatibility) standards are as follows:

EMS (Electromagnetic Susceptibility): EN 61000-6-2

EMI (Electromagnetic Interference): EN 61000-6-4

(Radiated emission: 10-m regulations)

#### **Low Voltage Directive**

Always ensure that devices operating at voltages of 50 to 1,000 V AC and 75 to 1,500 V DC meet the required safety standards for EN 61131-2.

### 6-3 Conformance to EC Directives

The CompoNet Master Units comply with EC Directives. To ensure that the machine or device in which a CompoNet Master Unit is used complies with EC Directives, the CompoNet Master Unit must be installed as follows:

- 1,2,3...**
1. The CompoNet Master Unit must be installed within a control panel.
  2. You must use reinforced insulation or double insulation for the DC power supplies used for the communications power supply and I/O power supplies.
  3. CompoNet Master Units complying with EC Directives also comply with the Common Emission Standard (EN 61000-6-4). Radiated emission characteristics (10-m regulations) may vary depending on the configuration of the control panel used, other devices connected to the control panel, wiring, and other conditions. You must therefore confirm that the overall machine or equipment complies with EC Directives.

# SECTION 1

## Smart Slaves and Features

This section provides an overview of the DeviceNet DRT2-series Smart Slaves, including lists of models, and information on features that were not included in the DRT1-series Slaves.

- 1-1 DRT2 Features ..... 2
  - 1-1-1 Overview..... 2
  - 1-1-2 Features..... 2
- 1-2 DRT2 Slaves ..... 7
  - 1-2-1 General-purpose Slaves ..... 7
  - 1-2-2 Environment-resistive Slaves ..... 9
  - 1-2-3 Analog Slaves ..... 10
  - 1-2-4 Smart Slave Feature Support ..... 11
  - 1-2-5 Installing and Connecting Slaves ..... 17

## 1-1 DRT2 Features

### 1-1-1 Overview

The DRT2-series Smart Slaves can be used to collect various information that improves the operating rate of the equipment, in addition to performing basic input and output of ON/OFF signals.

A maintenance system can be configured separately from the control system. This enables a balance between control and maintenance using an existing DeviceNet network, contributing to reduced startup time, shorter recovery time when problems occur, and preventative maintenance of the equipment.

- Control System

The default settings for remote I/O communications with the PLC are the same as for previous Slaves, whereby real I/O is allocated for each node address. One difference with previous Slaves is that an area for Smart Slave status information can be allocated to the Smart Slaves within the IN Area of the Master. This is in addition to real I/O. (Settings are performed using the Configurator or explicit messages.)

- Maintenance System

The Configurator is used to read and write various types of equipment information stored in the DRT2 Slave. The same equipment information can also be read and written by sending explicit messages to the DRT2 Slave from the Master (such as a PLC or a DeviceNet Master Board mounted in a personal computer).

### 1-1-2 Features

DRT2-series Slaves have the following features.

#### **Common Features**

##### **Node Addresses Set Using Rotary Switches**

Node addresses are set using rotary switches, which are clearer than the previous DIP switch settings. Node addresses can also be set from the Configurator.

##### **Automatically Detected Baud Rate**

Previous models required the baud rate to be set using the Slave's DIP switch, but Smart Slaves do not require the baud rate to be set. The Smart Slave automatically operates at the baud rate of the Master Unit.

##### **Remote I/O Communications**

When using default remote I/O communications from the PLC for DRT2 Slaves, only real I/O is allocated. This is the same method used by the previous DRT1 Slaves.

The following status information can be allocated in addition to real I/O, in the IN Area of the Master by using the Configurator or explicit messages to make user settings (default connection path settings):

Generic Status Flags, Top/Valley Detection Timing Flags, Analog Status Flags

##### **Network Power Supply Voltage Monitor**

As part of the remote I/O function, Network power supply voltages (present, peak, and bottom values) can be recorded in the Slave. The Configurator can be used to read the information. The Slave also maintains a set value for monitoring the voltage, and will provide notification in the Status Area if the voltage drops below the set level.

##### **Unit Conduction Time Monitor**

The time that the Slave's internal circuit power is ON can be totaled and recorded. The Configurator or explicit messages can be used to read the information. The Slave also maintains a set value for monitoring the Unit's ON time, and will provide notification in the Status Area if the set time is reached.

<b>Slave Comments</b>	User-set names can be assigned and saved in the Slave for each Unit.
<b>I/O Comments</b>	User-set names can be assigned and saved in the Slave for each of the I/O contacts, such as sensors or valves, that are connected to the Slave.
<b>Communications Error History Monitor</b>	The error statuses (communications error cause code and communications power supply voltage when error occurred) for the last four communications errors that occurred can be recorded in the Slave. The Configurator can be used to read the information.
<b>Last Maintenance Date</b>	The dates on which maintenance is performed can be written to the Unit using the Configurator.

### **Features of General-purpose Slaves and Environment-resistive Slaves**

<b>No Internal Circuit Power Supply Wiring for Slaves</b>	The communications power supply is used for the internal circuit power for the Unit. This eliminates the need to wire the Unit's internal circuit power supply.
<b>I/O Power Status Monitor</b>	The I/O Power Status Monitor is used to detect whether the I/O power supply is connected and provide notification in the Status Area. The Configurator or explicit messages can be used to read the information.
<b>Input Filter</b>	The input filter is used to read the input value several times during the set interval and remove irregular data caused by noise and switch chattering. This function can also be used to create ON/OFF delays.
<b>Power ON Delay</b>	The I/O power supply can be monitored to stop any input when the I/O power is OFF and for 100 ms after it is turned ON. This function prevents incorrect inputs caused by inrush current at startup after the I/O power is turned ON.
<b>Contact Operation Counter</b>	The number of times each input or output contact changes from OFF to ON can be counted (maximum resolution: 50 Hz). The Configurator or explicit messages can be used to read the information. The Slave also maintains a set value for monitoring the number of contact operations, and will provide notification in the Status Area if the set value is reached.
	<b>Note</b> The Contact Operation Counter and Total ON Time Monitor cannot be used at the same time for a single contact.
<b>Total ON Time Monitor</b>	This function is used to total and record in the Slave the time that devices, such as sensors and relays, that are connected to the Slave are ON. The Configurator or explicit messages can be used to read the information. The Slave also maintains a set value for monitoring the total ON time, and will provide notification in the Status Area if the set value is reached.
	<b>Note</b> The Total ON Time Monitor and Contact Operation Counter cannot be used at the same time for a single contact.
<b>Detection of Sensor Power Short-circuit</b>	The I/O power supply current is monitored and if the current exceeds the rated current, it is judged to be a sensor power short-circuit and the sensor power output is forced OFF. Environment-resistive Slaves, Advanced Models: The number of the shorted contact can be checked from the I/O status indicators. The Configurator or explicit message communications can also be used to read which connector or sensor has shorted. The Slave will automatically reset when the cause of the short-circuit has been removed. Sensor Connector Terminals: When a short-circuit is detected in any of the contacts, the I/O power for the Unit is turned OFF. A short-circuit detection error can be confirmed using the SHTO indicator. The Configurator or explicit messages can also be used to read the error status.

Screw-less Clamp Terminals (DRT2-□D32SLH-1): The number of the shorted contact can be checked using the I/O status indicators. The Configurator or explicit message communications can also be used to read which terminal sensor has shorted. The Slave will automatically reset when the cause of the short-circuit has been removed.

#### **External Load Short-circuit Detection**

External Load Short-circuit Detection monitors the output load current and if the Output Unit's current exceeds the set value, it is judged to be an external load short-circuit and the output is forced OFF to prevent damage to the Unit's output circuit. When an external load short-circuit is detected, the External Load Short-circuit Detection Flag turns ON. The External Load Short-circuit Detection Flag can be read by either the Configurator or explicit messages.

#### **Sensor Disconnected Detection**

The I/O power supply current is monitored and it is determined whether a sensor is disconnected. The Configurator or explicit messages can be used to read which sensor is not connected.

### **Features of Remote I/O Terminals (General-purpose Slaves)**

#### **Detachable Terminal Block**

The terminal block can be detached.

#### **Expansion Units**

A Basic Unit can be combined with an Expansion Unit. The various I/O combinations that are possible, such as 16 inputs and 8 outputs, or 24 inputs (16 inputs plus 8 inputs), increase the system configuration possibilities.

#### **Operation Time Monitor**

##### **■ Basic I/O Unit + Expansion Unit**

The time that lapses from when the output turns ON to when the input turns ON can be measured at high speed from the Slave (without relying on the ladder program). The Slave also maintains a set value for monitoring the operation time, and will provide notification the Status Area if the set time is exceeded. The Configurator or explicit messages can be used to read the information.

The DRT2-MD16(-1) cannot be expanded with an Expansion Unit, but its operation time can be monitored.

##### **■ Three-tier Terminal Block**

In contrast to the existing Units, which could only measure I/O (OUT-IN), these Units can also measure operating times for IN-IN and OUT-OUT combinations. In addition, the trigger edge (ON to OFF or OFF to ON) can be selected and input and output numbers can be freely combined for flexible settings.

### **Features of Connector Terminals (General-purpose Slaves)**

#### **Wired with Industry Standard Sensor Connectors (Sensor Connector Terminals)**

Industry standard sensor connectors are provided to standardize the I/O wiring, thereby making wiring simpler and less labor intensive.

#### **Operation Time Monitor**

##### **■ Sensor Connector Terminals**

The time that lapses from when the output turns ON to when the input turns ON can be measured at high speed from the Slave (without relying on the ladder program). The Slave also maintains a set value for monitoring the operation time, and will provide notification the Status Area if the set time is exceeded. The Configurator or explicit messages can be used to read the information.

### ■ MIL Connector Terminals/Board Terminals

In contrast to the existing Units, which could only measure I/O (OUT-IN), these Units can also measure operating times for IN-IN and OUT-OUT combinations. In addition, the trigger edge (ON to OFF or OFF to ON) can be selected and input and output numbers can be freely combined for flexible settings.

## Features of Screw-less Clamp Terminals (General-purpose Slaves)

### Labor-saving Clamp Terminal Block

For I/O wiring, a screw-less clamp terminal block is provided. Wiring is reduced by the use of post terminals that can be easily inserted and then later removed by simply pressing a release button.

### Detection Functions (Standard Feature, DRT2-□D□□SLH(-1) Only)

Detection results can be read by using the Configurator or explicit messages if the sensor short-circuit/disconnected and external load short-circuit/disconnected detection functions are used. The error location can be rapidly specified and restored.

### Operation Time Monitor

In contrast to the existing Units, which could only measure I/O (OUT-IN), these Units can also measure operating times for IN-IN and OUT-OUT combinations. In addition, the trigger edge (ON to OFF or OFF to ON) can be selected and input and output numbers can be freely combined for flexible settings.

## Features of Environment-resistive Terminals

### Dust-proof and Waterproof Construction (IP67) for High Resistance to Environment

The environment-resistive construction enables usage in locations subject to oil and water splashes (IP67). An environment-resistive box is not required, enabling greater downsizing and reducing wiring labor.

### No Power Supply Wiring for Input Devices (Advanced Models Only)

Power for communications, internal circuits, and input devices is shared, making wiring necessary only for the communications power supply. With standard models, a power supply must be wired to I/O devices.

### Connect High-load Devices (1.5 A Max., Advanced Models Only)

The rated output current is 1.5 A, allowing the direct connection of output devices with high loads.

### Operation Time Monitor (DRT2-MD16CL(-1) and DRT2-□D04CL Only)

The time that lapses from when the output turns ON to when the input turns ON can be measured at high speed from the Slave (without relying on the ladder program). The Slave also maintains a set value for monitoring the operation time, and will provide notification the Status Area if the set time is exceeded. The Configurator or explicit messages can be used to read the information.

## Analog Slave Features

### Setting the Number of AD Conversion Points (DRT2-AD04 Only)

The conversion cycle when all 4 analog input points are used is 4 ms max. The AD conversion cycle can be shortened by reducing the number of points used (i.e., the number of AD conversion points).

### Moving Average (Input Units Only)

Analog Input Terminals and Temperature Input Terminals can calculate the average of the past eight analog input values to produce a stable input value even when the input value is unsteady.

### Scaling

Scaling allows values to be converted according to the industry unit required by the user. It reduces the number of operations requiring ladder programming in the Master CPU Unit. Scaling also supports an offset function for compensating for errors in scaled values.

### Peak/Bottom Hold (Input Units Only)

The maximum (peak) and minimum (bottom) values input to Analog Input Terminals and Temperature Input Terminals can be held. These values can then

	be compared with alarm set values, and flags turned ON as appropriate to indicate the status (comparator function).
<b>Top/Valley Hold (Input Units Only)</b>	The top and valley values for values input to Analog Input Terminals and Temperature Input Terminals can be held. The timing of tops and valleys can be monitored with the Top/Valley Detection Timing Flags. The top and valley values can be compared with alarm set values, and flags turned ON as appropriate to indicate the status (comparator function).
<b>Rate of Change (Input Units Only)</b>	The rate of change for values input to Analog Input Terminals and Temperature Input Terminals can be obtained for each sampling cycle.
<b>Comparator (Input Units Only)</b>	Values input to Analog Input Terminals and Temperature Input Terminals or values after math processing can be compared to the alarm set values (HH, H, L, and LL), and the result indicated with the Analog Status Flags. If the result is outside the set range, the Normal Flag (pass signal) is turned ON.
<b>Off-wire Detection (Input Units Only)</b>	<p>With Analog Input Terminals, disconnections can be detected in wiring for analog (voltage or current) inputs that are enabled as AD conversion points. The status can be checked at the Master using the Off-wire Detection Flag. This function is valid only for the input ranges 4 to 20 mA and 1 to 5 V.</p> <p>With Temperature Input Terminals, disconnections can be detected for each sensor input. The status can be checked at the Master using the Off-wire Detection Flag.</p>
<b>User Adjustment</b>	Input (or output) can be adjusted to compensate for errors in the input (or output) voltage or current resulting from the characteristics or connection methods of the input (or output) device. Compensation is performed by applying linear conversion based on the points corresponding to 0% and 100%.
<b>Cumulative Counter</b>	A cumulated value that approximates the integral of analog input (or output) values or a temperature input value over time can be calculated and read. Monitor values can also be set in the Unit. When the cumulated count value exceeds the set monitor value, the Cumulative Counter Flag in the area for Generic Status Flags turns ON.
<b>Communications Error Output (Output Units Only)</b>	The values output by Output Units when errors occur can be set for each output.
<b>Top/Valley Count Function</b>	The number of times the top or valley value is reached can be counted for an application that has fixed cycles of temperature changes. Explicit messages can be used to see if the number of times that is counted has exceeded a monitoring set value.
<b>Temperature Range Timing Function</b>	The length of time that the system is at a user-set temperature or within a user-set temperature range can be measured in seconds. Explicit messages can be used to see if the measured time has exceeded a monitoring set value.
<b>Input Temperature Variation Detection Function</b>	A relative comparison can be made between two inputs (0 to 3) and to detect temperature differences between two inputs or with a monitoring set value. Explicit messages can be used to see if the temperature difference has exceeded a monitoring set value.

## 1-2 DRT2 Slaves

The DRT2-series Smart Slaves are classified into the following categories.

- General-purpose Slaves  
Slaves with digital I/O functions using standard connectors for communications cables.
- Environment-resistive Slaves  
Slaves with I/O functions using round waterproof connectors for communications cables.
- Analog Slaves  
Slaves with analog I/O functions using standard connectors for communications cables.

### 1-2-1 General-purpose Slaves

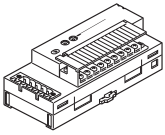
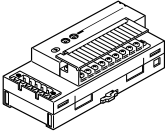
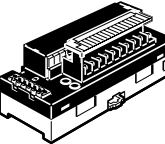
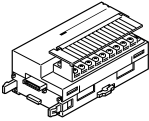
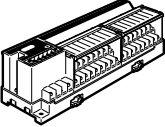
	Name	Appearance	I/O points	Model number	Remarks
Remote I/O Terminals	Remote I/O Terminals with Transistors		8 input points (NPN)	DRT2-ID08	Terminal block mounted/removed using screws.
			8 input points (PNP)	DRT2-ID08-1	
			8 output points (NPN)	DRT2-OD08	
			8 output points (PNP)	DRT2-OD08-1	
			16 input points (NPN)	DRT2-ID16	
			16 input points (PNP)	DRT2-ID16-1	
			16 output points (NPN)	DRT2-OD16	
			16 output points (PNP)	DRT2-OD16-1	
			8 input points/8 output points (NPN)	DRT2-MD16	
			8 input points/8 output points (PNP)	DRT2-MD16-1	
	Remote I/O Terminal with Relay Outputs		16 output points	DRT2-ROS16	Relay outputs
	Remote I/O Terminal Expansion Units with Transistors		16 input points (NPN)	XWT-ID16	Expansion Unit for increasing inputs or outputs of the Basic Unit.
			16 input points (PNP)	XWT-ID16-1	
			16 output points (NPN)	XWT-OD16	
			16 output points (PNP)	XWT-OD16-1	
			8 input points (NPN)	XWT-ID08	
			8 input points (PNP)	XWT-ID08-1	
			8 output points (NPN)	XWT-OD08	
			8 output points (PNP)	XWT-OD08-1	
Remote I/O Terminals with 3-tier Terminal Blocks and Transistors		16 input points (NPN)	DRT2-ID16TA	Wiring locations easy to find (wiring to the same terminal not required). Cannot be expanded with an Expansion Unit.	
		16 input points (PNP)	DRT2-ID16TA-1		
		16 output points (NPN)	DRT2-OD16TA		
		16 output points (PNP)	DRT2-OD16TA-1		
		8 input points/8 output points (NPN)	DRT2-MD16TA		
		8 input points/8 output points (PNP)	DRT2-MD16TA-1		

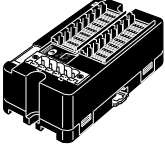
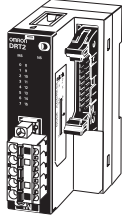
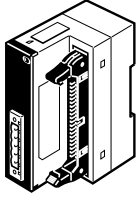
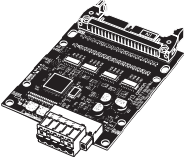
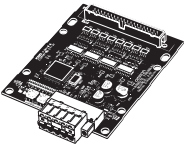

	Name	Appearance	I/O points	Model number	Remarks
Connector Terminals	Sensor Connector Terminals with Transistors		16 input points (NPN)	DRT2-ID16S	Use industry standard sensor connectors.
			16 input points (PNP)	DRT2-ID16S-1	
			8 input points/8 output points (NPN)	DRT2-MD16S	
			8 input points/8 output points (PNP)	DRT2-MD16S-1	
	MIL Connector Terminals with Transistors		16 input points (NPN)	DRT2-ID16ML	Connects to relay terminal using MIL cable.
			16 input points (PNP)	DRT2-ID16ML-1	
			16 output points (NPN)	DRT2-OD16ML	
			16 output points (PNP)	DRT2-OD16ML-1	
			16 input points (NPN)	DRT2-ID16MLX	A connecting cable (10 cm) is included.
			16 input points (PNP)	DRT2-ID16MLX-1	
			16 output points (NPN)	DRT2-OD16MLX	
			16 output points (PNP)	DRT2-OD16MLX-1	
			32 input points (NPN)	DRT2-ID32ML	Connects to relay terminal using MIL cable.
			32 input points (PNP)	DRT2-ID32ML-1	
32 output points (NPN)	DRT2-OD32ML				
32 output points (PNP)	DRT2-OD32ML-1				
16 input points/16 output points (NPN)	DRT2-MD32ML				
16 input points/16 output points (PNP)	DRT2-MD32ML-1				
Connector Terminals	Board MIL Connector Terminals with Transistors		32 input points (NPN)	DRT2-ID32B	MIL connectors mounted parallel to board
			32 input points (PNP)	DRT2-ID32B-1	
			32 output points (NPN)	DRT2-OD32B	
			32 output points (PNP)	DRT2-OD32B-1	
			16 input points/16 output points (NPN)	DRT2-MD32B	
			16 input points/16 output points (PNP)	DRT2-MD32B-1	
		32 input points (NPN)	DRT2-ID32BV	MIL connectors mounted perpendicular to board	
		32 input points (PNP)	DRT2-ID32BV-1		
		32 output points (NPN)	DRT2-OD32BV		
		32 output points (PNP)	DRT2-OD32BV-1		
		16 input points/16 output points (NPN)	DRT2-MD32BV		
		16 input points/16 output points (PNP)	DRT2-MD32BV-1		

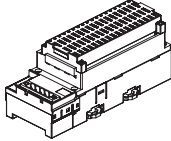
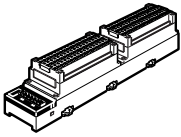
	Name	Appearance	I/O points	Model number	Remarks	
Screw-less Clamp Terminals	Screw-less Clamp Terminal with Transistors		16 input points (NPN)	DRT2-ID16SL	Without detection function	
			16 input points (PNP)	DRT2-ID16SL-1		
			16 output points (NPN)	DRT2-OD16SL		
			16 output points (PNP)	DRT2-OD16SL-1		
			16 input points (NPN)	DRT2-ID16SLH		With detection function
			16 input points (PNP)	DRT2-ID16SLH-1		
			16 output points (NPN)	DRT2-OD16SLH		
			16 output points (PNP)	DRT2-OD16SLH-1		
			32 input points (NPN)	DRT2-ID32SL	Without detection function	
			32 input points (PNP)	DRT2-ID32SL-1		
			32 output points (NPN)	DRT2-OD32SL		
			32 output points (PNP)	DRT2-OD32SL-1		
			16 input points/16 output points (NPN)	DRT2-MD32SL	With detection function	
			16 input points/16 output points (PNP)	DRT2-MD32SL-1		
			32 input points (NPN)	DRT2-ID32SLH		
			32 input points (PNP)	DRT2-ID32SLH-1		
	32 output points (NPN)		DRT2-OD32SLH			
	32 output points (PNP)		DRT2-OD32SLH-1			
	16 input points/16 output points (NPN)		DRT2-MD32SLH			
	16 input points/16 output points (PNP)		DRT2-MD32SLH-1			

**1-2-2 Environment-resistive Slaves**

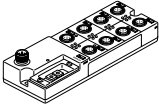
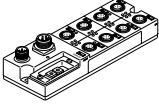
Name	Appearance	I/O points	Model number	Remarks
Environment-resistive Terminals, Advanced Models		8 input points (NPN)	DRT2-ID08C	Waterproof, oil-proof, and spatter-proof construction (IP67). Equipped with detection functions.
		8 input points (PNP)	DRT2-ID08C-1	
		16 input points (NPN)	DRT2-HD16C	
		16 input points (PNP)	DRT2-HD16C-1	
		8 output points (NPN)	DRT2-OD08C	
		8 output points (PNP)	DRT2-OD08C-1	

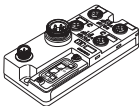
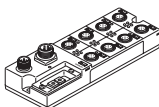
Name	Appearance	I/O points	Model number	Remarks
Environment-resistant Terminals, Standard Models		4 input points (NPN)	DRT2-ID04CL	Waterproof, oil-proof, and spatter-proof construction (IP67). Not equipped with detection functions.
		4 input points (PNP)	DRT2-ID04CL-1	
		4 output points (NPN)	DRT2-OD04CL	
		4 output points (PNP)	DRT2-OD04CL-1	
		8 input points (NPN)	DRT2-ID08CL	
		8 input points (PNP)	DRT2-ID08CL-1	
		16 input points (NPN)	DRT2-HD16CL	
		16 input points (PNP)	DRT2-HD16CL-1	
		8 output points (NPN)	DRT2-OD08CL	
		8 output points (PNP)	DRT2-OD08CL-1	
		16 output points (NPN)	DRT2-WD16CL	
		16 output points (PNP)	DRT2-WD16CL-1	
		8 input points/8 output points (NPN)	DRT2-MD16CL	
		8 input points/8 output points (PNP)	DRT2-MD16CL-1	

### 1-2-3 Analog Slaves

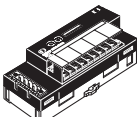
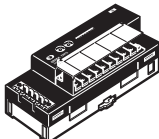
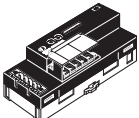
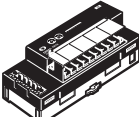
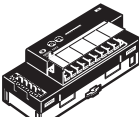
Name	Appearance	I/O points	Model number	Remarks
Analog Terminals		4 input points (0 to 5 V, 1 to 5 V, 0 to 10 V, -10 to 10 V, 0 to 20 mA, 4 to 20 mA)	DRT2-AD04	Terminal block mounted/ removed using screws. The DRT2-AD04H is a High-resolution Terminal (1/30,000 FS).
		4 input points (0 to 5 V, 1 to 5 V, 0 to 10 V, 0 to 20 mA, 4 to 20 mA)	DRT2-AD04H	
		2 output points (0 to 5 V, 1 to 5 V, 0 to 10 V, -10 to 10 V, 0 to 20 mA, 4 to 20 mA)	DRT2-DA02	
Temperature Input Terminals		4 input points (Switchable between R, S, K1, K2, J1, J1, T, E, B, N, L1, L2, U, W, and PL2.)	DRT2-TS04T	Thermocouple input
		4 input points (Switchable between PT, JPT, PT2, and JPT2.)	DRT2-TS04P	Platinum resistance thermometer input

## 1-2-4 Smart Slave Feature Support

Yes: Supported.; No: Not supported.

Feature	Type	General-purpose Slaves						
		Remote I/O Terminals						
		Standard			Relay outputs	3-tier terminal block		
		Input	Output	Mix	Output	Input	Output	Mix
Operation Time Monitor	Yes (for inputs + outputs only) (See note 1.)				Yes			
Contact Operation Counter	Yes							
Unit ON Time Monitor	Yes							
Total ON Time Monitor	Yes							
Naming Units	Yes							
Naming connected devices	Yes							
Network Power Voltage Monitor	Yes							
I/O Power Status Monitor	Yes			No	Yes			
Communications Error History Monitor	Yes							
Input filter	Yes	No	Yes	No	Yes	No	Yes	
Preventing malfunctions caused by inrush current at startup	Yes	No	Yes	No	Yes	No	Yes	
Sensor power short-circuit detection	No							
Sensor disconnected detection	No							
External load short-circuit detection	No							
External load disconnected detection	No							
Detachable terminal block construction	Yes							
Automatic baud rate detection	Yes							
Power supply wiring not required for Units	Yes							
Power supply wiring not required for input devices	No			Yes	No	No	No	
Expansion using Expansion Units	Yes (See note 2.)				No	No	No	
Scaling	No							
User adjustment	No							
Last maintenance date	Yes							
Cumulative counter	No							
Moving average	No							
Setting the number of AD conversion points	No							
Peak/bottom hold	No							
Top/valley hold	No							
Rate of change	No							
Comparator	No							
Communications error output	No							

- Note**
1. The Operation Time Monitor cannot be used with the DRT2-□D08(-1).
  2. The DRT2-□D08(-1) and DRT2-MD16(-1) cannot be expanded with an Expansion Unit.
  3. The Contact Operation Counter and Total ON Time Monitor cannot be used at the same time for the same contact.

Yes: Supported.; No: Not supported.

Feature	Type		General-purpose Slaves		
	Sensor Connector Terminals				
	Sensor connectors		MIL connectors (Board Terminals)		
	Input	Mix	Input	Output	Mix
Operation Time Monitor	No	Yes	Yes		
Contact Operation Counter	Yes				
Unit ON Time Monitor	Yes				
Total ON Time Monitor	Yes				
Naming Units	Yes				
Naming connected devices	Yes				
Network Power Voltage Monitor	Yes				
I/O Power Status Monitor	No		Yes		
Communications Error History Monitor	Yes				
Input filter	Yes		Yes	No	Yes
Preventing malfunctions caused by inrush current at startup	Yes		Yes	No	Yes
Sensor power short-circuit detection	Yes		No		
Sensor disconnected detection	No				
External load short-circuit detection	No	Yes	No		
External load disconnected detection	No				
Detachable terminal block construction	No				
Automatic baud rate detection	Yes				
Power supply wiring not required for Units	Yes				
Power supply wiring not required for input devices	Yes		No		
Expansion using Expansion Units	No				
Scaling	No				
User adjustment	No				
Last maintenance date	Yes				
Cumulative counter	No				
Moving average	No				
Setting the number of AD conversion points	No				
Peak/bottom hold	No				
Top/valley hold	No				
Rate of change	No				
Comparator	No				
Communications error output	No				

**Note** The Contact Operation Counter and Total ON Time Monitor cannot be used at the same time for the same contact.

Yes: Supported.; No: Not supported.

Feature	Type	General-purpose Slaves			
		Screw-less Clamp Terminals			
		DRT2-□D16SLH (With detection function)		DRT2-□D16SL (Without detection function)	
		Input	Output	Input	Output
Operation Time Monitor	Yes				
Contact Operation Counter	Yes				
Unit ON Time Monitor	Yes				
Total ON Time Monitor	Yes				
Naming Units	Yes				
Naming connected devices	Yes				
Network Power Voltage Monitor	Yes				
I/O Power Status Monitor	Yes				
Communications Error History Monitor	Yes				
Input filter	Yes	No	Yes	No	
Preventing malfunctions caused by inrush current at startup	Yes	No	Yes	No	
Sensor power short-circuit detection	Yes	No	No		
Sensor disconnected detection	Yes	No	No		
External load short-circuit detection	No	Yes	No		
External load disconnected detection	No	Yes	No		
Detachable terminal block construction	Yes				
Automatic baud rate detection	Yes				
Power supply wiring not required for Units	Yes				
Power supply wiring not required for input devices	No				
Expansion using Expansion Units	No				
Scaling	No				
User adjustment	No				
Last maintenance date	Yes				
Cumulative counter	No				
Moving average	No				
Setting the number of AD conversion points	No				
Peak/bottom hold	No				
Top/valley hold	No				
Rate of change	No				
Comparator	No				
Communications error output	No				

The Contact Operation Counter and Total ON Time Monitor cannot be used at the same time for the same contact.

Yes: Supported.; No: Not supported.

Feature	Type	General-purpose Slaves					
		Screw-less Clamp Terminals					
		DRT2-□D32SLH (With detection function)			DRT2-□D32SL (Without detection function)		
		Input	Output	Mix	Input	Output	Mix
Operation Time Monitor		Yes			Yes		
Contact Operation Counter		Yes					
Unit ON Time Monitor		Yes					
Total ON Time Monitor		Yes					
Naming Units		Yes					
Naming connected devices		Yes					
Network Power Voltage Monitor		Yes					
I/O Power Status Monitor		Yes					
Communications Error History Monitor		Yes					
Input filter		Yes	No	Yes	Yes	No	Yes
Preventing malfunctions caused by inrush current at startup		Yes	No	Yes	Yes	No	Yes
Sensor power short-circuit detection		Yes	No	Yes	No		
Sensor disconnected detection		Yes	No	Yes	No		
External load short-circuit detection		No					
External load disconnected detection		No	Yes	Yes	No		
Detachable terminal block construction		Yes					
Automatic baud rate detection		Yes					
Power supply wiring not required for Units		Yes					
Power supply wiring not required for input devices		No					
Expansion using Expansion Units		No					
Scaling		No					
User adjustment		No					
Last maintenance date		Yes					
Cumulative counter		No					
Moving average		No					
Setting the number of AD conversion points		No					
Peak/bottom hold		No					
Top/valley hold		No					
Rate of change		No					
Comparator		No					
Communications error output		No					

**Note** The Contact Operation Counter and Total ON Time Monitor cannot be used at the same time for the same contact.

Yes: Supported.; No: Not supported.

Feature	Type	Environment-resistive Terminals				
		Advanced models		Standard models		
		Input	Output	Input	Output	Mix
Operation Time Monitor	No	No	No (See note.)		Yes	
Contact Operation Counter	Yes	Yes	Yes	Yes	Yes	
Unit ON Time Monitor	Yes	Yes	Yes	Yes	Yes	
Total ON Time Monitor	Yes	Yes	Yes	Yes	Yes	
Naming Units	Yes	Yes	Yes	Yes	Yes	
Naming connected devices	Yes	Yes	Yes	Yes	Yes	
Network Power Voltage Monitor	Yes	Yes	Yes	Yes	Yes	
I/O Power Status Monitor	No	Yes	Yes	Yes	Yes	
Communications Error History Monitor	Yes	Yes	Yes	Yes	Yes	
Input filter	Yes	No	Yes	No	Yes	
Preventing malfunctions caused by inrush current at startup	Yes	No	Yes	No	Yes	
Sensor power short-circuit detection	Yes	No	No	No	No	
Sensor disconnected detection	Yes	No	No	No	No	
External load short-circuit detection	No	Yes	No	No	No	
External load disconnected detection	No	No	No	No	No	
Detachable terminal block construction	No	No	No	No	No	
Automatic baud rate detection	Yes	Yes	Yes	Yes	Yes	
Power supply wiring not required for Units	Yes	Yes	Yes	Yes	Yes	
Power supply wiring not required for input devices	Yes	No	No	No	No	
Expansion using Expansion Units	No	No	No	No	No	
Scaling	No	No	No	No	No	
User adjustment	No	No	No	No	No	
Last maintenance date	Yes	Yes	Yes	Yes	Yes	
Cumulative counter	No	No	No	No	No	
Moving average	No	No	No	No	No	
Setting the number of AD conversion points	No	No	No	No	No	
Peak/bottom hold	No	No	No	No	No	
Top/valley hold	No	No	No	No	No	
Rate of change	No	No	No	No	No	
Comparator	No	No	No	No	No	
Communications error output	No	No	No	No	No	
Top/valley count function	No	No	No	No	No	
Temperature range timing function	No	No	No	No	No	
Input temperature variation detection function	No	No	No	No	No	

- Note**
- (1) The Operation Time Monitor can be used with the DRT2-□D04CL(-1).
  - (2) The Contact Operation Counter and Total ON Time Monitor cannot be used at the same time for the same contact.



Yes: Supported.; No: Not supported.

Feature	Type	Analog Slaves			Temperature Input Terminal
		Analog Terminals			
		DRT2-AD04	DRT2-AD04H	DRT2-DA02	
		Input		Output	
Operation Time Monitor	No	No	No	No	
Contact Operation Counter	No	No	No	No	
Unit ON Time Monitor	Yes	Yes	Yes	Yes	
Total ON Time Monitor	No	No	No	No	
Naming Units	Yes	Yes	Yes	Yes	
Naming connected devices	Yes	Yes	Yes	Yes	
Network Power Voltage Monitor	Yes	Yes	Yes	Yes	
I/O Power Status Monitor	No	No	No	No	
Communications Error History Monitor	Yes	Yes	Yes	Yes	
Input filter	No	No	No	No	
Preventing malfunctions caused by inrush current at startup	No	No	No	No	
Sensor power short-circuit detection	No	No	No	No	
Sensor disconnected detection	No	No	No	No	
External load short-circuit detection	No	No	No	No	
External load disconnected detection	No	No	No	No	
Detachable terminal block construction	Yes	Yes	Yes	Yes	
Automatic baud rate detection	Yes	Yes	Yes	Yes	
Power supply wiring not required for Units	Yes	Yes	Yes	Yes	
Power supply wiring not required for input devices	No	No	No	No	
Expansion using Expansion Units	No	No	No	No	
Scaling	Yes	Yes	Yes	Yes	
User adjustment	Yes	Yes	Yes	Yes	
Last maintenance date	Yes	Yes	Yes	Yes	
Cumulative counter	Yes	Yes	Yes	Yes	
Moving average	Yes	Yes	No	Yes	
Setting the number of AD conversion points	Yes	No	No	No	
Peak/bottom hold	Yes	Yes	No	Yes	
Top/valley hold	Yes	Yes	No	Yes	
Rate of change	Yes	Yes	No	Yes	
Comparator	Yes	Yes	No	Yes	
Communications error output	No	No	Yes	No	
Top/valley count function	No	No	No	Yes	
Temperature range timing function	No	No	No	Yes	
Input temperature variation detection function	No	No	No	Yes	

**Note** The Contact Operation Counter and Total ON Time Monitor cannot be used at the same time for the same contact.

### 1-2-5 Installing and Connecting Slaves

Slave type	Communications cables	Name	Model	Slave installation	I/O connection method	Internal power supply	I/O power supply
General-purpose Slaves	Standard rectangular connector	Remote I/O Terminals with Transistors	DRT2-ID08	DIN Track	M3 terminal block (detachable)	Shares communications power supply.	Requires external power supply.
			DRT2-ID08-1				
			DRT2-OD08				
			DRT2-OD08-1				
			DRT2-ID16				
			DRT2-ID16-1				
			DRT2-OD16				
			DRT2-OD16-1				
			DRT2-MD16				
			DRT2-MD16-1				
		Remote I/O Terminals with 3-tier Terminal Blocks and Transistors	DRT2-ID16TA	DIN Track or screws			
			DRT2-ID16TA-1				
			DRT2-OD16TA				
			DRT2-OD16TA-1				
			DRT2-MD16TA				
			DRT2-MD16TA-1				
		Remote I/O Terminal Expansion Units with Transistors	XWT-ID16	DIN Track			
			XWT-ID16-1				
	XWT-OD16						
	XWT-OD16-1						
	XWT-ID08						
	XWT-ID08-1						
	XWT-OD08						
	XWT-OD08-1						
	Remote I/O Terminal with Relay Outputs	DRT2-ROS16		Relay	Shares communications power supply. An external power supply is required, however, for MD16S-1 outputs.		
	Sensor Connector Terminals with Transistors	DRT2-ID16S	DIN Track or screws	Industry standard connector			
		DRT2-ID16S-1					
		DRT2-MD16S					
DRT2-MD16S-1							
MIL Connector Terminals with Transistors	DRT2-ID16ML	DIN Track or screws with Mounting Bracket	MIL connector	Shares communications power supply.	Requires external power supply.		
	DRT2-ID16ML-1						
	DRT2-OD16ML						
	DRT2-OD16ML-1						
	DRT2-ID16MLX						
	DRT2-ID16MLX-1						
	DRT2-OD16MLX						
	DRT2-OD16MLX-1						

Slave type	Communi-cations cables	Name	Model	Slave installation	I/O con-nection method	Internal power sup-ply	I/O power supply
General-pur- pose Slaves	Standard rectangular connector	MIL Connec- tor Terminals with Transis- tors	DRT2-ID32ML	DIN Track or screws with Mount- ing Bracket	MIL con- nector	Shares communi- cations power sup- ply.	Requires external power sup- ply.
			DRT2-ID32ML-1				
			DRT2-OD32ML				
			DRT2-OD32ML-1				
			DRT2-MD32ML				
			DRT2-MD32ML-1				
		Board MIL Connector Terminals with Transis- tors	DRT2-ID32B	Screws			
			DRT2-ID32B-1				
			DRT2-OD32B				
			DRT2-OD32B-1				
			DRT2-MD32B				
			DRT2-MD32B-1				
			DRT2-ID32BV				
			DRT2-ID32BV-1				
			DRT2-OD32BV				
			DRT2-OD32BV-1				
			DRT2-MD32BV				
			DRT2-MD32BV-1				
	Screw-less Clamp Termi- nal with Tran- sistors	DRT2-ID16SL	DIN Track	Screw-less clamp			
		DRT2-ID16SL-1					
		DRT2-OD16SL					
		DRT2-OD16SL-1					
		DRT2-ID32SL					
		DRT2-ID32SL-1					
		DRT2-OD32SL					
		DRT2-OD32SL-1					
		DRT2-MD32SL					
		DRT2MD32SL-1					
		DRT2-ID16SLH					
		DRT2-ID16SLH-1					
		DRT2-OD16SLH					
		DRT2-OD16SLH-1					
		DRT2-ID32SLH					
DRT2-ID32SLH-1							
DRT2-OD32SLH							
DRT2-OD32SLH-1							
DRT2-MD32SLH							
DRT2-MD32SLH-1							

**Note** Use the following table to determine the I/O power supply for the Expansion Unit.

Device combination	I/O power supply to Expansion Unit
Basic Input Unit (IN) + Expansion Input Unit (IN): Example: DRT2-ID16+XWT-ID16	Not required. (I/O power supply shared with Basic Unit.)
Basic Input Unit (IN) + Expansion Output Unit (OUT): Example: DRT2-ID16+XWT-OD16	Required. (I/O power supply required for both Units.)

Device combination	I/O power supply to Expansion Unit
Basic Output Unit (OUT) + Expansion Input Unit (IN): Example: DRT2-OD16+XWT-ID16	Required. (I/O power supply required for both Units.)
Basic Output Unit (OUT) + Expansion Output Unit (OUT): Example: DRT2-OD16+XWT-OD16	Required. (I/O power supply required for both Units.)
Basic Output Unit (OUT) + Expansion Output Unit (IN): Example: DRT2-ROS16+XWT-ID16	Required. (I/O power supply required for Expansion Unit only.)
Basic Output Unit (OUT) + Expansion Output Unit (OUT): Example: DRT2-ROS16+XWT-OD16	Required. (I/O power supply required for Expansion Unit only)

Slave type	Communications cables	Name	Model	Slave installation	I/O connection method	Connecting devices	Internal power supply	I/O power supply
Environment-resistant Slaves	Round communications connector	Environment-resistant Terminals	DRT2-ID08C	Screw-mounted	Round waterproof connector (for XS2)	Cable with XS2 Connector + Sensor with Connector	Shares communications power supply	Shares communications power supply
			DRT2-ID08C-1					
			DRT2-HD16C					
			DRT2-HD16C-1					
			DRT2-OD08C					
			DRT2-OD08C-1					
			DRT2-ID04CL					
			DRT2-ID04CL-1					
			DRT2-OD04CL					
			DRT2-OD04CL-1					
			DRT2-ID08CL					
			DRT2-ID08CL-1					
			DRT2-HD16CL					
			DRT2-HD16CL-1					
			DRT2-OD08CL					
			DRT2-OD08CL-1					
			DRT2-WD16CL					
			DRT2-WD16CL-1					
DRT2-MD16CL								
DRT2-MD16CL-1								
Analog Slaves	Standard rectangular connector	Analog Terminals	DRT2-AD04	DIN Track	M3 terminal block (detachable)	Terminal block connection		Separate power supply required for connected devices, such as sensors and actuators.
			DRT2-AD04H					
			DRT2-DA02					
		Temperature Input Terminals	DRT2-TS04T					
			DRT2-TS04P					



# SECTION 2

## Example System Startup

This section provides information on hardware aspects of Masters and Slaves connected to a DeviceNet Network to ensure the proper operation of the system. Included are system configuration examples, basic procedures for wiring, details on mounting and setting Master and Slave Units, procedures for connecting cables and power supplies, creating I/O tables, creating and registering scan lists, and checking operation of the system.

2-1	Basic Procedures and Configuration Examples . . . . .	22
2-1-1	Basic Procedures. . . . .	22
2-1-2	System Configuration Example . . . . .	22
2-2	Preparations. . . . .	23
2-2-1	Selecting Units . . . . .	23
2-2-2	Wiring. . . . .	23
2-2-3	Communications Power Supply . . . . .	23
2-3	Setting and Wiring Hardware . . . . .	24
2-3-1	Mounting and Setting the Master Unit. . . . .	24
2-3-2	Mounting and Setting Slaves . . . . .	25
2-3-3	Mounting Connecting Devices . . . . .	26
2-3-4	Connecting Cables . . . . .	26
2-4	Starting Communications . . . . .	27
2-4-1	Creating I/O Tables for the Master Unit. . . . .	27
2-4-2	Starting the System. . . . .	28
2-4-3	Creating and Registering Scan Lists. . . . .	28
2-5	Checking Operation . . . . .	29
2-5-1	Indicator Status. . . . .	29
2-5-2	Reading and Writing Data . . . . .	29

## 2-1 Basic Procedures and Configuration Examples

The examples shown here provide the basic operating procedures for DeviceNet.

### 2-1-1 Basic Procedures

The basic application procedures are as follows: For details on settings and connections, refer to the operation manual for the Master Unit. For further details on Slave Units, refer to *SECTION 5 General-purpose Slaves* and *SECTION 6 Environment-resistive Slaves*.

#### Preparing the Units

- 1,2,3...**
1. Select the appropriate Units. Refer to page 23.
  2. Determine the appropriate wiring method. Refer to page 23.
  3. Determine the appropriate method for supplying communications power. Refer to page 23.

#### Setting and Wiring Hardware

- 1,2,3...**
1. Separate and lay the cables.
  2. Mount the Master Unit and specify the correct settings. Refer to page 24.
  3. Mount the Slave Units and specify the correct settings. Refer to page 25.
  4. Mount other devices to be connected to the Network. Refer to page 26.
  5. Connect the cables. Refer to page 26.
  6. Wire the I/O cables. Refer to page 26.

#### Starting Communications

- 1,2,3...**
1. Create the I/O tables. Refer to page 27.
  2. Start up the system. Refer to page 28.
  3. Create and register the scan list. Refer to page 28.

#### Checking Operations

- 1,2,3...**
1. Check the status of the indicators on the Unit. Refer to page 29.
  2. Check that data is reading and writing properly. Refer to page 29.

**Note** The examples provided in this section show the minimum settings to operate the system. If details on other settings for actual operation are required, refer to the operation manual for the Master Unit. For further details on Slave Units, refer to *SECTION 5 General-purpose Slaves* and *SECTION 7 Analog Slaves*.

### 2-1-2 System Configuration Example

The following diagram shows the operating procedure using a system configuration example.

The system configuration shown here uses Thin Cables.

The following diagram is simplified, so it does not include the separate I/O power supply that must be provided to the Output Unit (or Expansion Output Unit).

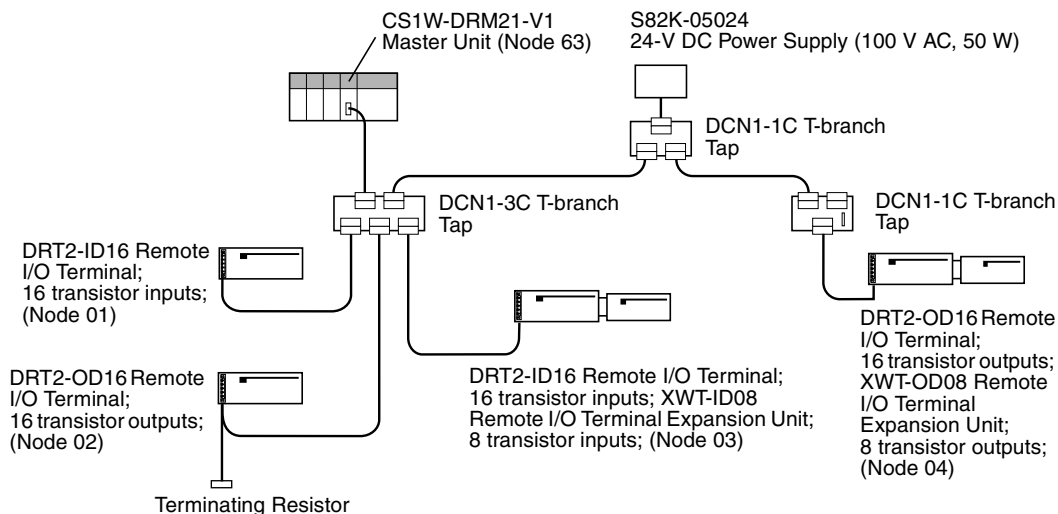

## 2-2 Preparations

### 2-2-1 Selecting Units

Select the following Units as shown in *2-1-2 System Configuration Example*.

Master Unit: CS1W-DRM21-V1

Slave Units: DRT2-ID16 + XWT-ID08

DRT2-OD16 + XWT-OD08

There is a complete line of OMRON Master Units and Slave Units available that are compatible with DeviceNet. Select Units that suit the needs of the system.

### 2-2-2 Wiring

Either Thick Cables or Thin Cables can be used to wire a DeviceNet Network. Flexible branching of cables is possible by using either T-branch Taps or multi-drop connections.

Restrictions on the maximum network length and total branch line length depend on the baud rate and type of cable used. For details on network configurations and specifications, refer to the DeviceNet Operation Manual (W267).

### 2-2-3 Communications Power Supply

Each node (Master or Slave) must be supplied with a 24-V DC power supply for proper DeviceNet communications.

The communications power, however, can be supplied by communications cables and does not require separate wiring.

For systems that have a short maximum network length, power can be supplied to all nodes by using one communications power supply.

Various conditions, constraints, and measures affect how the communications power is supplied. In the examples shown here, the power is supplied from one communications power supply, and communications cables are connected using T-branch Taps.

For details on methods of supplying communications power, refer to the DeviceNet Operation Manual (W267).



**Note** Use the OMRON Connectors shown below when using Thick Cables and multi-drop connections for wiring.  
XW4B-05C4-TF-D (With set screws)

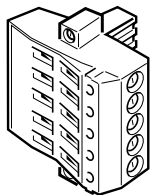

XW4G-05C4-TD-D (With set screws)

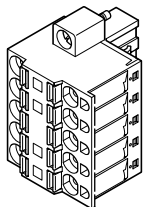

## 2-3 Setting and Wiring Hardware

Use the following procedures to mount, set, and wire the hardware.

### 2-3-1 Mounting and Setting the Master Unit

#### Settings

The components, functions, and switch settings for the CS1W-DRM21, CS1W-DRM21-V1 or CJ1W-DRM21 Master Unit mounted to a CS/CJ-series PLC are shown as an example in the following diagram.

For information on switch settings, refer to the operation manual for the Master Unit.

#### CS1W-DRM21 (-V1)

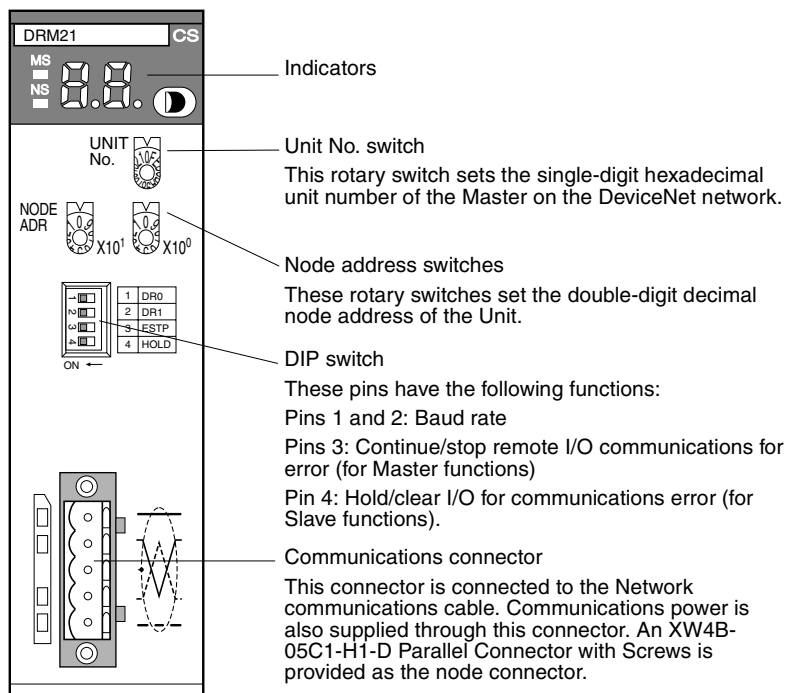

**CJ1W-DRM21**

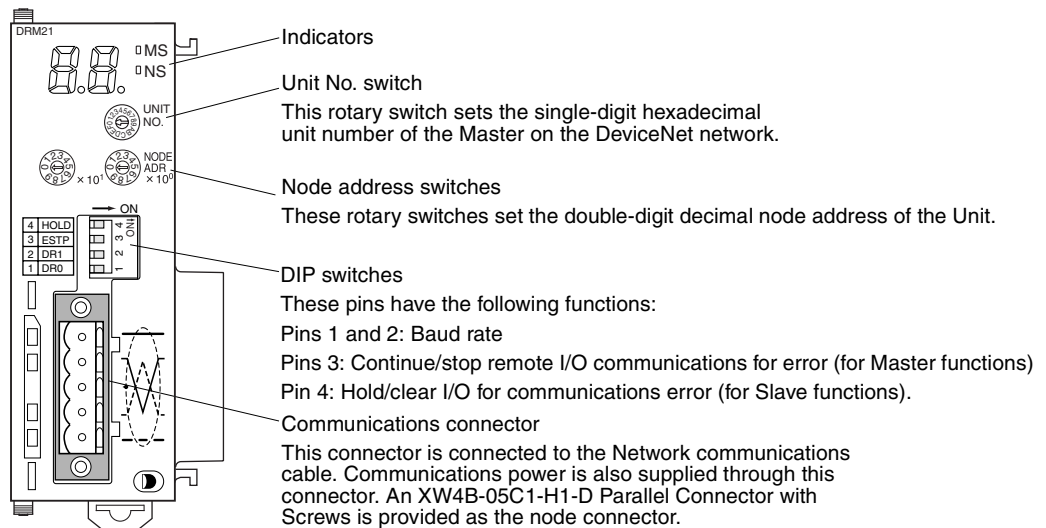

**Mounting**

The Master Unit is mounted to the Backplane of the PLC in the same way as other Units are normally mounted. CJ-series Master Units have no Backplane, so connect the Units together by joining the connectors. For details on mounting Master Units to PLCs, and PLCs to control panels, refer to the applicable PLC Operation Manual.

**2-3-2 Mounting and Setting Slaves**

**Settings**

The following example shows Slave settings. For details on how to set Slaves, refer to *SECTION 5 General-purpose Slaves* to *SECTION 7 Analog Slaves*.

- DRT2-ID16 Remote I/O Terminals (transistor inputs)  
Node address: 01
- DRT2-OD16 Remote I/O Terminals (transistor outputs)  
Node address: 02
- DRT2-ID16 Remote I/O Terminals (transistor inputs)  
XWT-ID08 Remote I/O Terminal Expansion Unit  
Node address: 03
- DRT2-OD16 Remote I/O Terminals (transistor outputs)  
XWT-OD08 Remote I/O Terminal Expansion Unit  
Node address: 04

**Mounting**

Remote I/O Terminals are mounted by fixing to a DIN Track, as shown in the following example.

Secure the bottom of the Slave Unit to a 35-mm DIN Track, or secure the Slave Unit to the track between two End Plates.

**Mounting Example**

The following diagram shows all Units except the PLC node mounted to DIN Tracks.

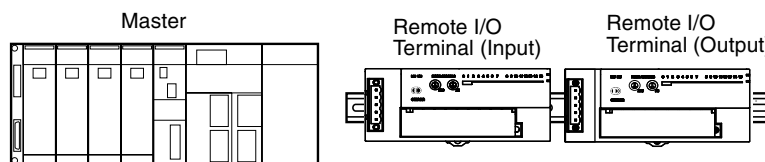

### 2-3-3 Mounting Connecting Devices

The following connecting devices require being mounted:

- T-branch Taps: Secure to the control panel with screws, or mount to a DIN Track.
- Terminal-block Terminating Resistors: Secure to the control panel with screws.

### 2-3-4 Connecting Cables

#### Connecting Communications Cables

Connect the Master Unit and T-branch Taps, T-branch Taps and T-branch Taps, and T-branch Taps and Slaves using Thin DeviceNet Communications Cables, as shown in the following diagram.

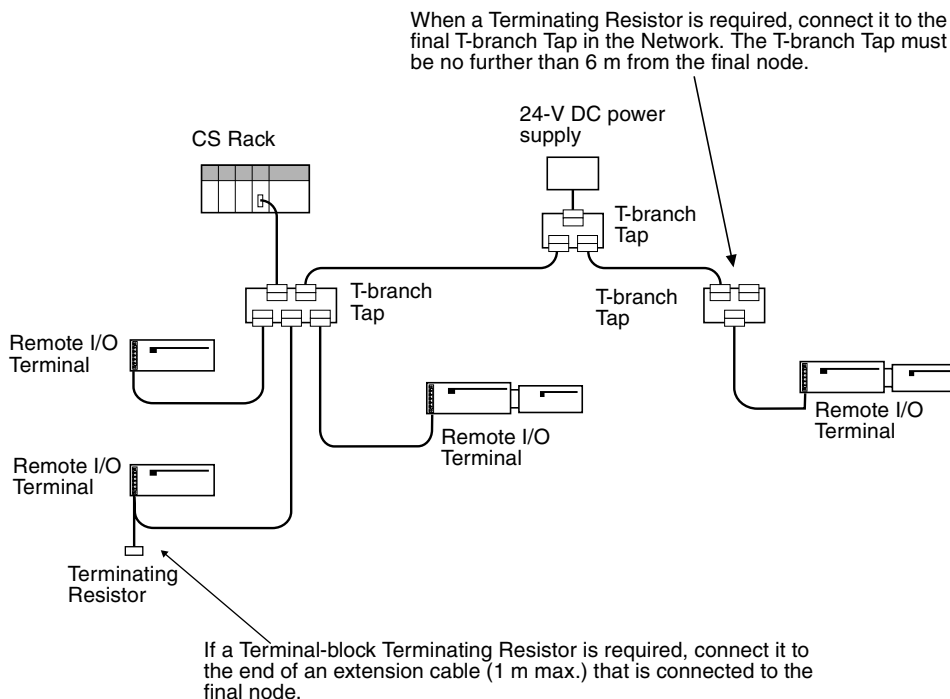

Use the following procedure to connect the cables. Refer to 5-2 *Connecting Communications Cables to General-purpose Slaves* for details.

- 1,2,3...
1. Prepare the communications cables and attach the connectors to the cables.
  2. Connect the communications cable connectors to the node connectors on the Master Unit, T-branch Taps, and Slaves.

#### Wiring the I/O Power Supply

If required, an I/O power supply for I/O devices is connected to the Remote I/O Terminals. Connect M3 crimp terminals to the power lines and then connect them to the terminal block.

#### Wiring I/O

Wire the I/O to the Remote I/O Terminals. Connect M3 crimp terminals to the signal lines and then connect them to the terminal block.

## 2-4 Starting Communications

After setting and wiring the hardware, turn ON the communications power supply, the internal power supply of each node, and the I/O power supply, and then start communications using the following procedure.

### 2-4-1 Creating I/O Tables for the Master Unit

I/O tables must be created in the CPU Unit to distinguish between the different Slaves mounted to the PLC. Turn ON the PLC to which the Master Unit is mounted, connect the Peripheral Devices to the PLC, and create the I/O tables. After the I/O tables have been created, turn OFF the power to the PLC.

The following example shows the procedure for creating I/O tables using a Programming Console. For details on creating I/O tables, refer to the operation manual for the Peripheral Device being used.

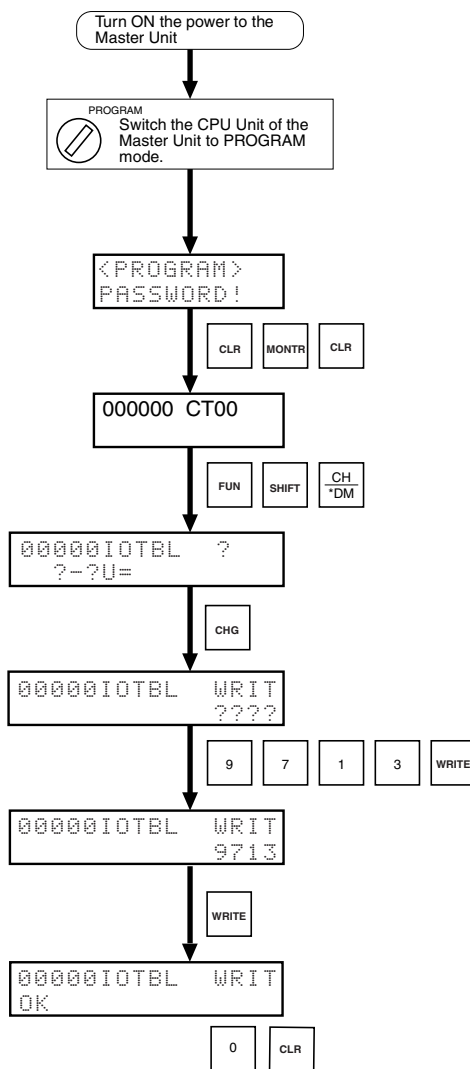

## 2-4-2 Starting the System

Turn ON the communications power supply and the power to other nodes in the following order.

- 1,2,3...**
1. Turn ON the communications power supply.
  2. Turn ON the power to each Slave.
  3. Turn ON the power to the Master Unit.

**Note** The power supplies listed above can all be turned ON simultaneously. The external I/O power supply can be turned ON at any time.

## 2-4-3 Creating and Registering Scan Lists

Scan lists are lists that register the information that is transferred between Master Units and Slaves. The Master Unit compares the scan list with the status of the Slave currently being communicated with, so communications with the Slave are always being checked.

For details on scan lists and remote I/O communications, refer to the operation manual for the Master Unit.

**Note** When a scan list is disabled, communications are possible with all Slaves on the DeviceNet Network with fixed allocations. Without scan lists, however, the Master Unit cannot check if there is an error in a Slave. For normal operations, always enable the scan lists.

### Precautions

#### **User I/O Allocations**

The user can allocate any words for Slave I/O for the DeviceNet I/O Areas (IN Area, OUT Area) in the Master Unit.

When user allocations are used, scan lists must be created with a DeviceNet Configurator and registered in the Master Unit. The scan list is enabled as soon as it is registered, and remote I/O communications start according to the scan list.

For details, refer to the DeviceNet Operation Manual (W267) and the DeviceNet Configurator Operation Manual (W328).

#### **Fixed I/O Allocations**

Slave I/O is allocated in the DeviceNet I/O area (IN Area, OUT Area) in the Master Unit in the same order as the Slave node addresses.

When fixed allocations are used, the scan lists are automatically created and registered using the Master Unit's software switches. The scan list is enabled as soon as it is registered, and remote I/O communications start according to the scan list. When scan list is enabled, the mode is called the scan list-enabled mode.

The registered scan lists can be cleared using the software switches. When scan lists are cleared (disabled), the mode is called the scan list-disabled mode.

### Creating and Registering Fixed Allocation Scan Lists

The method of creating and registering scan lists for fixed allocation using Programming Console and a CS/CJ-series Master Unit is explained here. For details on operating Peripheral Devices, refer to the operation manual for the Peripheral Device being used with the PLC. For details on creating scan lists, refer to the operation manual for the Master Unit.

**Creating and Registering Scan Lists**

Use the following procedure to create, register, and enable the scan lists. In the following example,  $n = 1500 + (25 \times \text{unit number})$ .

**Clearing and Creating Scan Lists**

Switch the operating mode switch to PROGRAM mode.

Enable the Master Unit functions. Set the Master Unit function enable switch (bit 06 of word n) from OFF to ON.

Clear the scan lists. Set the scan list clear switch (bit 01 of word n) from OFF to ON.

Select the fixed allocation areas 1 to 3. Set the Master Unit's setting switch for fixed allocation areas 1 to 3 (bit 00 of word n) from OFF to ON.

Enable the scan lists. Set the scan list enable switch (bit 00 of word n) from OFF to ON.

Switch the operating mode switch to RUN or MONITOR mode.

**Checking the Normal Slave Table**

Monitor the normal Slave table and check that the corresponding bits are ON. In the normal Slave table, the corresponding bits will turn ON for the nodes that are communicating normally.

## 2-5 Checking Operation

Use the procedures provided here to check that I/O communications are operating normally.

### 2-5-1 Indicator Status

I/O communications are operating normally if the MS and NS indicators for all nodes are lit green, and the 7-segment indicator on the front panel of the Master Unit is displaying the node address of the Master Unit as shown in the following diagram (when the Master Unit's node address is 00), and the scan list is enabled.

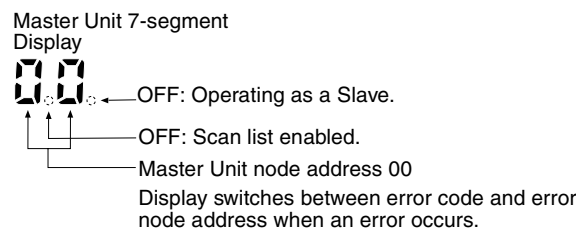

### 2-5-2 Reading and Writing Data

Connect the Peripheral Device for the PLC to the Master Unit, write the Master Unit's OUT Area and read the IN Area, and check that the data are the same in the Slaves.

Refer to the operation manual for the Master Unit for details on OUT Area and IN Area addresses and how to allocate Slave I/O.

**I/O between Remote I/O Terminals**

Create ladder programs in the PLC of the Master Unit, and check that when the switch on the DRT2-ID16 Input Terminal turns ON, the indicator on the DRT2-OD16 Output Terminal is ON.

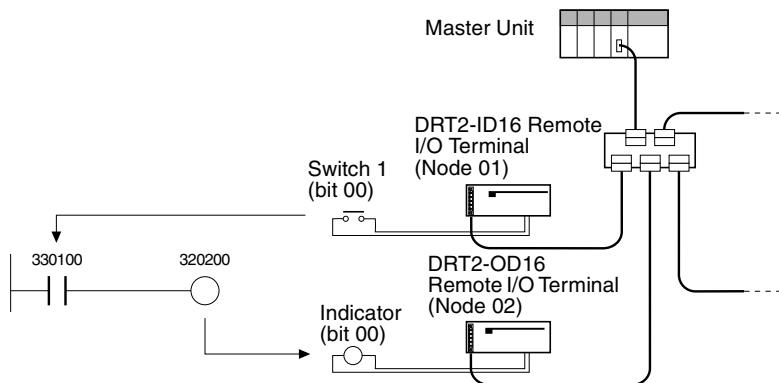

**Precautions**

In the system configuration examples in this section, Slave I/O is allocated in the Master Unit's CIO Area for fixed remote I/O communications as shown in the following diagram.

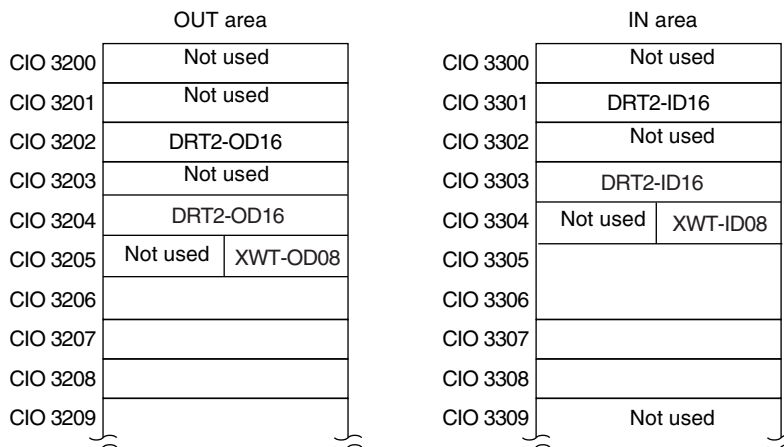

# SECTION 3

## Common Slave Specifications

This section provides specifications and indicator displays that are common to all Slaves. The allocation of remote I/O memory for Smart Slaves is also described here.

3-1	Common Slave Specifications .....	32
3-1-1	Communications Specifications .....	32
3-1-2	MS and NS Indicators. ....	32
3-2	DeviceNet Remote I/O Communications .....	34
3-2-1	Overview of Remote I/O Allocations for Smart Slaves .....	34
3-2-2	I/O Allocations for Smart Slaves .....	36
3-2-3	I/O Allocation with the Configurator (Ver. 2.□ or Later). ....	42



## 3-1 Common Slave Specifications

### 3-1-1 Communications Specifications

Item	Specifications			
Communications protocol	DeviceNet			
Supported connections (communications)	Remote I/O: Master-Slave connection (Poll/Bit-Strobe/COS/Cyclic) Conform to DeviceNet specifications.			
Connection forms	Combination of multi-drop and T-branch connections (for trunk or branch lines)			
Baud rate	500 kbps, 250 kbps, or 125 kbps			
Communications media	Special 5-wire cables (2 signal lines, 2 power lines, 1 shield line)			
Communications distances	Baud rate	Network length	Branch line length	Total branch line length
	500 kbps	100 m max (100 m max)	6 m max.	39 m max.
	250 kbps	250 m max (100 m max)	6 m max.	78 m max.
	125 kbps	500 m max (100 m max)	6 m max.	156 m max.
	Values in parentheses indicate the length when Thin Cables are used.			
Communications power supply	11 to 25 V DC			
Max. number of nodes	64 nodes (including Configurator when used)			
Max. number of Slaves	63 Slaves			
Communications cycle time	Without Configurator: 16 Input Slaves (16-pt) 16 Output Slaves (16-pt) Baud rate of 500 kbps: Cycle time: 9.3 ms			
Error control	CRC error check			

### 3-1-2 MS and NS Indicators

This section describes the meanings of MS and NS indicators for the Slave Units.

The MS (Module Status) indicator displays the status of a node on the network.

The NS (Network Status) indicator displays the status of the entire network.

The MS and NS indicators can be green or red and they can be ON, flashing, or OFF.

Indicator	Color	Status	Definition	Meaning
MS	Green	Lit	Device operational	Normal operating status.
	Red	Lit	Unrecoverable fault	Unit hardware error (watchdog timer error).
		Flashing	Minor fault	Switch settings incorrect, etc.
	---	Not lit	No power	Power is not being supplied to the Slave Unit. Waiting for initial processing to start. The Unit is being reset.

<b>Indicator</b>	<b>Color</b>	<b>Status</b>	<b>Definition</b>	<b>Meaning</b>
NS	Green	Lit	Online/connected	Network is operating normally (communications established).
		Flashing	Online/ not connected	Network is operating normally, but communications have not been established.
	Red	Lit	Critical link failure	Communications error (Unit has detected that network communications are not possible). Node address duplication Bus Off error
		Flashing	Connection time-out	Communications time-out.
	---	Not lit	Not powered/Not online	Checking for node address duplication at the Master. Switch settings are incorrect. Power supply is OFF.

### 3-2 DeviceNet Remote I/O Communications

This section describes how DRT2-slave data can be allocated for remote I/O communications with the Master Unit.

#### 3-2-1 Overview of Remote I/O Allocations for Smart Slaves

Unlike the DRT1-series Slaves, the DRT2-series Smart Slaves store data internally. When necessary, the user can specify which data is allocated for remote I/O communications with the Master Unit. (Allocation is not required, however, for the default I/O data.)

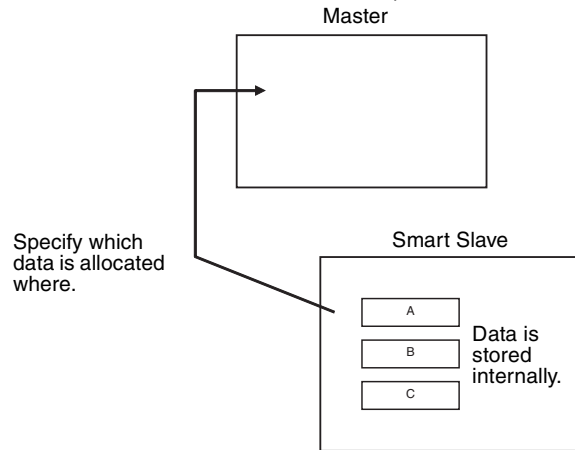

- Data can be specified in either of the two ways described below.

<ul style="list-style-type: none"> <li>• Select a data pattern (fixed combination) using the Slave's default connection path setting.</li> </ul>	<ul style="list-style-type: none"> <li>• Select individual data as desired using the Master's connection setting.</li> </ul>
<p>Either fixed allocation or user allocation is possible.</p>	<p>Only possible with user allocation and if the Master Unit is a CS/CJ-series DeviceNet Unit.</p>

#### Smart Slave I/O Allocation Methods

Smart Slave data can be allocated to the Master Unit for remote I/O communications in any of the ways described below.

**Fixed Allocation**

Type	Allocating default I/O data	Allocating selected I/O data (patterns)
<b>Description</b>	I/O data is allocated to fixed addresses in the Master Unit in order of node address.	Selected I/O data (pattern) is allocated to fixed addresses in the Master Unit.
<b>Method</b>	Configurator not used.	Configurator used to select I/O data (pattern).
<b>Configuration</b>	<p>The diagram shows a Master CPU Unit with I/O memory containing blocks A and B. An arrow labeled 'Node address order' points downwards. An arrow labeled 'Allocation' points from the Master's I/O memory to a Smart Slave's I/O data, which also contains blocks A and B.</p>	<p>The diagram shows a Master CPU Unit with I/O memory containing blocks A and C. An arrow labeled 'Node address order' points downwards. A Smart Slave's I/O data (patterns) contains blocks A, B, C, D, and E. Block A is highlighted with an arrow labeled 'Allocation'. A computer icon represents the configurator, with an arrow pointing to the Slave's I/O data and text: 'Select I/O data pattern (fixed combination)'. Another arrow points from the configurator to the Master's I/O memory with text: 'Select I/O from the Configurator's Edit Device Parameters Window for the Slave.'</p>
<b>Setting method with Configurator</b>	None	In the Slave's Edit Device Parameters Window, select the data in the Slave from the pull-down menu for the Slave's default connection path, and execute download.

**User Allocation**

Type	Allocating default I/O data	Allocating selected I/O data (patterns)
<b>Description</b>	I/O data is allocated to user-defined addresses in the Master Unit.	Selected I/O data (pattern) is allocated to user-defined addresses in the Master Unit.
<b>Method</b>	Configurator used to allocate user-defined addresses.	1. Configurator used to select I/O data (pattern). 2. Selected data allocated to user-defined memory addresses.
<b>Configuration</b>	<p>The diagram shows a Master CPU Unit with I/O memory containing blocks A and B. A computer icon represents the configurator with an arrow pointing to the Master's I/O memory and text: 'Allocate I/O to user-defined addresses using the Configurator.' An arrow labeled 'Allocation' points from the Master's I/O memory to a Smart Slave's I/O data, which contains blocks A and B.</p>	<p>The diagram shows a Master CPU Unit with I/O memory containing blocks A and C. A computer icon represents the configurator with an arrow pointing to the Master's I/O memory and text: '2. Allocate to user-defined addresses.' A Smart Slave's I/O data (patterns) contains blocks A, B, C, D, and E. Block A is highlighted with an arrow labeled 'Allocation'. A computer icon represents the configurator with an arrow pointing to the Slave's I/O data and text: '1. Select I/O data pattern (fixed combination)'. Another arrow points from the configurator to the Master's I/O memory with text: 'Select I/O from the Configurator's Edit Device Parameters Window for the Slave, and allocate to user-defined addresses.'</p>
<b>Setting method with Configurator</b>	In the Master's Edit Device Parameters Window, allocate Slave I/O.	1. In the Slave's Edit Device Parameters Window, select the data in the Slave from pull-down menu for the Slave's default connection path, and execute download. 2. In the Master's Edit Device Parameters Window, allocate Slave I/O.

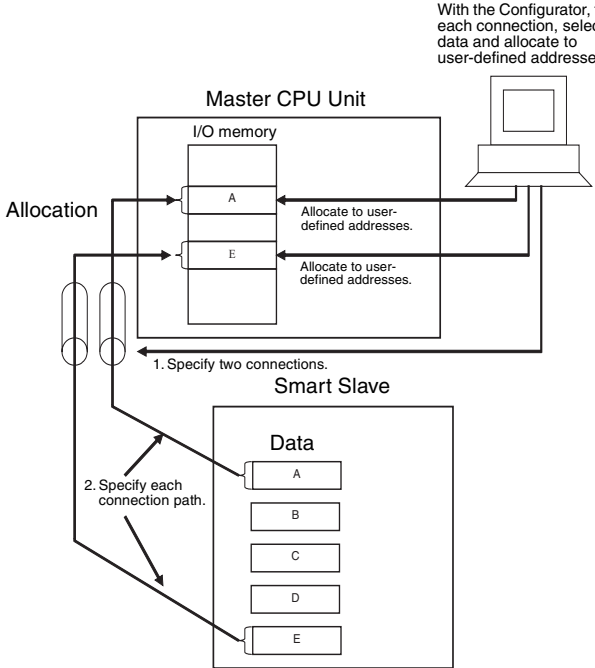
Type	Selecting I/O data and allocating to user-defined addresses
<b>Description</b>	Select up to two types of I/O data, and allocate to user-defined addresses in the Master Unit.
<b>Method</b>	1. Select up to two types of I/O data using the Configurator. 2. Allocate the selected I/O data to user-defined addresses in the Master Unit.
<b>Configuration</b>	<p>With the Configurator, for each connection, select data and allocate to user-defined addresses.</p>  <p>Allocation</p> <p>Master CPU Unit</p> <p>I/O memory</p> <p>A</p> <p>E</p> <p>Allocate to user-defined addresses.</p> <p>Allocate to user-defined addresses.</p> <p>1. Specify two connections.</p> <p>Smart Slave</p> <p>Data</p> <p>A</p> <p>B</p> <p>C</p> <p>D</p> <p>E</p> <p>2. Specify each connection path.</p> <p><b>Note:</b> Up to two connections can be specified from CS/CJ-series Master Units.</p>
<b>Setting method with Configurator</b>	1. In the Master's Edit Device Parameters Window, select the Smart Slave to be set, and specify the connection in the Advanced Setting Window. Select the I/O data (pattern) in the connection path setting. 2. In the Master's Edit Device Parameters Window, allocate Slave I/O.

**Note** The above method can be used only if the Master Unit is a CS/CJ-series DeviceNet Unit. When using a CVM1/CV-series DeviceNet Master Unit, a C200HX/HG/HE/HS DeviceNet Master Unit, or another company's Master Unit, select the I/O data from the pull-down menu for the default connection path in the Slave's Edit Device Parameters Window.

### 3-2-2 I/O Allocations for Smart Slaves

**General-purpose Slaves and Environment-resistive Slaves**

DRT2-slave data can be allocated for remote I/O communications with the Master Unit using any of the following methods.

- 1,2,3...**
1. Allocating only real I/O data (default)
  2. Allocating real I/O data and Generic Status Flags together
  3. Allocating real I/O data and Generic Status Flags independently
- Method 2 can be performed by selecting the I/O data and flags from the pull-down menu for the Slave's default connection path using the Configurator.
- Method 3 can be performed by allocating real I/O data and Generic Status Flags independently in the Master's connection path using the Configurator. (This method can be used only with CS/CJ-series Master Units.)

■ Example of Allocation Using Method 2

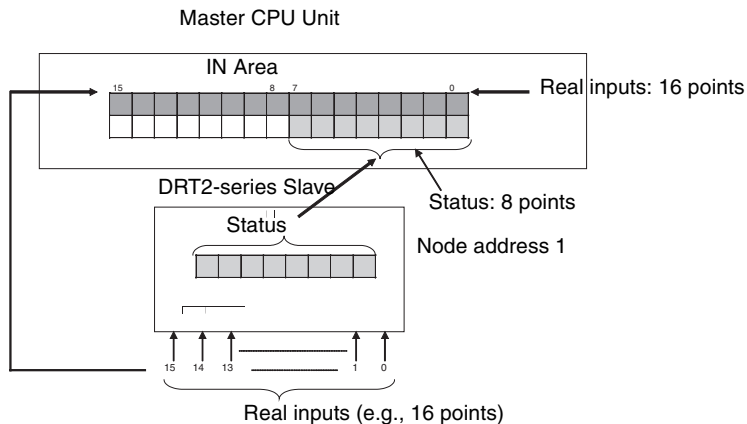

The Generic Status Flags are as follows:

Bit	Contents
0	Basic Unit's I/O Power Status Flag 0: I/O power supply ON 1: I/O power supply OFF
1	Expansion Unit's I/O Power Status Flag 0: I/O power supply ON 1: I/O power supply OFF
2	Network Power Voltage Drops Flag 0: Normal (Higher than set monitor value) 1: Error (Same as or lower than set monitor value)
3	Unit Maintenance Flag 0: Within range (Lower than set monitor value) 1: Out of range (Same as or higher than set monitor value)
4	Sensor Disconnected Flag (Screw-less Clamp Input and I/O Terminals, and Environment-resistive Input Terminals only) or External Load Disconnected Flag (Screw-less Clamp Output and I/O Terminals only) 0: Connected (all inputs connected) 1: Disconnected (at least one input is not connected) Cumulative Counter Flag (Analog Input Terminals and Temperature Input Terminals) 0: Normal 1: Error (monitoring set value exceeded)
5	Short-circuited Flag (Sensor Connector Terminals, Screw-less Clamp Input and I/O Terminals, and Environment-resistive Input Terminals only), or External Load Short-circuited Flag (Environment-resistive Output Terminals, Sensor Connector Terminals, I/O Units only) 0: Normal I/O (all I/O points normal) 1: Short-circuited I/O (one or more I/O point short-circuited) Unit Error Flag (Analog Input Terminals and Temperature Input Terminals) 0: Normal 1: Error (Data conversion stopped during to error in Unit.)

Bit	Contents
6	Operation Time Over Flag 0: Within range (all output-to-input sets are lower than set monitor value) 1: Out of range (one or more output-to-input set is same as or higher than set monitor value)
7	Connected Component Maintenance Flag 0: Within range (all I/O points are lower than set monitor value) 1: Out of range (one or more I/O point is same as or higher than set monitor value) Cold Junction Compensator Off-wire Flag 0: Normal 1: Error (off-wire connected)

**Note** 1. Bits 00 and 01 (I/O power supply voltage statuses 1 and 2, respectively) indicate the status of the system power supply, as follows:

Bit	Name	System configuration			
		Basic Unit only (Expansion Unit not used)	Basic Unit Input Terminal and Expansion Unit Input Terminal	Basic Unit Output or Input Terminal and Expansion Unit Output Terminal	Basic Unit Output Terminal and Expansion Unit Input Terminal
0	Basic Unit's I/O Power Status Flag	Basic Unit I/O power supply	Basic Unit I/O power supply	Basic Unit output power supply	Basic Unit output power supply
1	Expansion Unit's I/O Power Status Flag	--- (Not used.)	Expansion Unit output power supply	Expansion Unit input power supply	Expansion Unit input power supply

2. The Operation Time Over Flag functions only for Slaves with both inputs and outputs. It does not function for Slaves with only IN or OUT areas.

**Allocating Only Real I/O Data (Default)**

**Example 1: Using 16 inputs.**

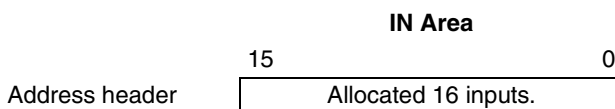

**Example 2: Using 16 outputs.**

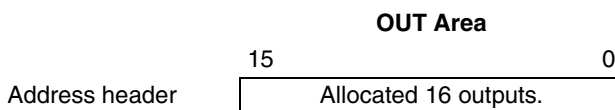

**Example 3: Using 32 inputs.**

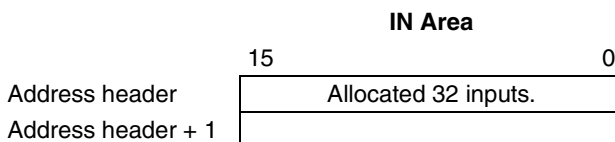

**Example 4: Using 16 inputs and 8 inputs (Expansion Unit).**

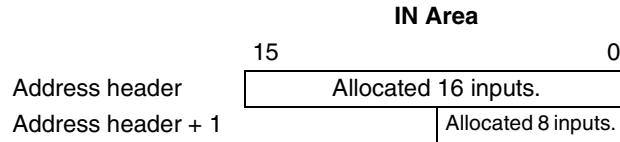

**Example 5: Using 16 outputs and 8 inputs (Expansion Unit).**

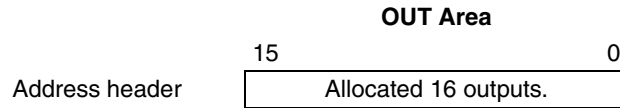

**Allocating Real I/O Data and Generic Status Flags Together**

The Generic Status Flags are for providing notification of the status of the Smart Slave to the host. They are allocated to the Master Unit's IN Area and consist of 8 bits.

**Example 1: Using 16 inputs.**

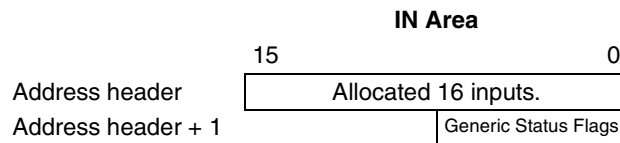

**Example 2: Using 16 outputs.**

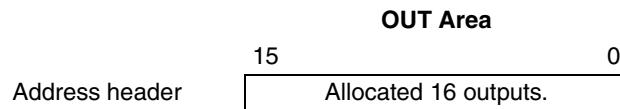

**Example 3: Using 32 inputs.**

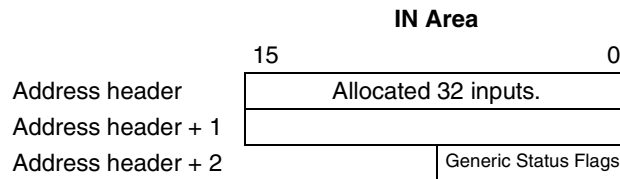

**Example 4: Using 16 inputs and 8 inputs (Expansion Unit).**

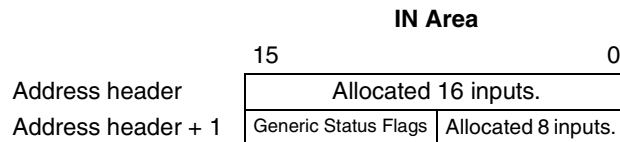

**Example 5: Using 16 outputs and 8 inputs (Expansion Unit).**

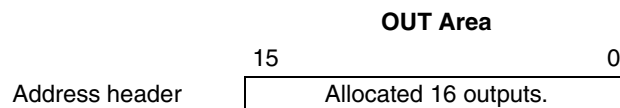



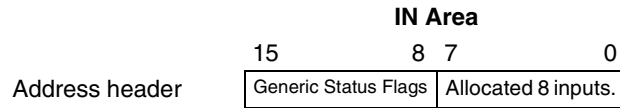

**Allocating Real I/O Data and Generic Status Flags Individually**

Instead of allocating real I/O and Generic Status Flags together, they can be allocated individually. This is only possible, however, if the Master Unit is a CS/CJ-series DeviceNet Unit and the Configurator is used.

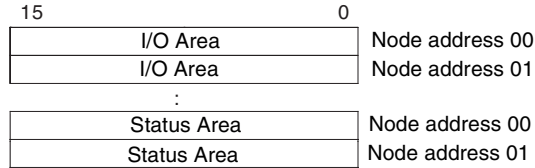

**Analog Slaves**

Data that is allocated for remote I/O communications can be selected using any of the following methods.

- 1,2,3...**
1. Allocating only analog values (default I/O data)
  2. Allocating a fixed I/O data pattern
  3. Allocating user-defined I/O data

With methods 2 and 3, the Configurator is used to specify the I/O data that is to be allocated. An outline of the methods used is given below.

**Allocating Fixed I/O Data Patterns**

There are eleven fixed I/O data patterns. The Configurator is used to select the desired I/O data pattern from the pull-down menu for the Slave's default connection path in the Edit Device Parameters Window.

**Allocating User-defined I/O Data**

Using the Configurator, the desired combination of I/O data can be allocated for the Master Unit connection. The desired connection is selected from the Master's Edit Device Parameters Window. Up to two of the eleven I/O data patterns can be selected for the connection paths of the connection.

**Note** If analog data is allocated to a COS connection, a frame will be sent to the host each analog conversion cycle. This will cause frames to be sent frequently, increasing network traffic and possibly affecting the communications cycle time.

The Generic Status Flags that are allocated are listed in the following tables.

**Analog Terminals**

Bit	Name	Description
0	---	Not supported (always 0).
1	---	Not supported (always 0).
2	Network Voltage Monitor Flag	ON as long as the network power supply remains below the monitoring set value.
3	Unit Conduction Time Monitor Flag	Turns ON when the time that power is supplied to the Unit exceeds the monitoring set value.
4	Cumulative Counter Flag	Turns ON when any of the cumulative values exceeds the monitoring set value.
5	Unit Error Flag	Turns ON when analog conversion stops due to an error in the Unit.
6	---	Not supported (always 0).
7	---	Not supported (always 0).

**Temperature Input Terminals**

Bit	Name	Description
0	---	Not supported (always 0).
1	---	Not supported (always 0).
2	Network Voltage Monitor Flag	ON as long as the network power supply remains below the monitoring set value.
3	Unit Conduction Time Monitor Flag	Turns ON when the time that power is supplied to the Unit exceeds the monitoring set value.
4	Temperature Data Cumulative Counter Flag	Turns ON when any of the cumulative values exceeds the monitoring set value.
5	Unit Error Flag	Turns ON when temperature conversion stops due to an error in the Unit.
6	---	Not supported (always 0).
7	Cold Junction Compensator Off-wire Flag	Turns ON when the cold junction compensator is disconnected. (DRT2-TS04T only)

The data (patterns) listed in the following tables can be allocated. Either the default setting can be used or allocations can be made in the master using the Configurator

■ **I/O Data for Analog Input Terminals (DRT2-AD04/AD04H)**

Data (patterns)
Analog Data 1 (8 input bytes) (default)
Analog Data 2 (8 input bytes)
Generic Status Flags (1 input byte)
Top/Valley Detection Timing Flags (2 input bytes)
Analog Status Flags (4 input bytes)
Analog Data 1 + Analog Data 2 (16 input bytes)
Top/Valley Detection Timing Flags + Generic Status Flags (3 input bytes)
Analog Status Flags + Generic Status Flags (5 input bytes)
Analog Data 1 + Top/Valley Detection Timing Flags (10 input bytes)
Analog Data 1 + Top/Valley Detection Timing Flags + Generic Status Flags (11 input bytes)
Hold Flags (1 output byte)

■ **I/O Data for Temperature Input Terminals (DRT2-TS4T/TS4P)**

Data (patterns)
Temperature Data 1 (8 input bytes) (default)
Temperature Data 1, 1/100 Display (16 input bytes)
Temperature Data 2 (8 input bytes) (default)
Temperature Data 2, 1/100 Display (16 input bytes)
Generic Status Flags (1 input byte)
Top/Valley Detection Timing Flags (2 input bytes)
Analog Status Flags (4 input bytes)
Temperature Data 1 + Temperature Data 2 (16 input bytes)
Temperature Data 1 + Temperature Data 2, 1/100 Display (32 input bytes)
Top/Valley Detection Timing Flags + Generic Status Flags (3 input bytes)
Analog Status Flags + Generic Status Flags (5 input bytes)
Temperature Data 1 + Top/Valley Detection Timing Flags (10 input bytes)
Temperature Data 1, 1/100 Display + Top/Valley Detection Timing Flags (18 input bytes)

Data (patterns)
Temperature Data 1 + Top/Valley Detection Timing Flags + Generic Status Flags (11 input bytes)
Temperature Data 1, 1/100 Display + Top/Valley Detection Timing Flags + Generic Status Flags (19 input bytes)
Hold Flags (1 output byte)

### 3-2-3 I/O Allocation with the Configurator (Ver. 2.□ or Later)

#### Allocating Selected I/O Data (Patterns)

In the Slave's Edit Device Parameters Window, select the required data from the pull-down list (default connection path setting) and execute download.

When performing user-defined allocation, in addition to the above, allocate Slave I/O in the Master's Edit Device Parameters Window.

**Note** Perform I/O allocation using this method if the Master Unit is a CVM1/CV-series DeviceNet Master Unit, a C200HX/HG/HE/HS DeviceNet Master Unit, or another company's Master Unit.

The setting example below is for allocating I/O data and Generic Status Flags for a General-purpose Slave. For details on the setting method for Analog Slaves, refer to 7-4-2 *I/O Data Allocation Methods*.

#### Procedure

Using the Configurator, set the default connection path in the Slave's Edit Device Parameters Window. Turn ON the power for the PLC connected to the Smart Slave and change the mode of the PLC to PROGRAM mode.

1,2,3...

1. Turn ON the power for the DRT2-series Smart Slave.
2. Click the right mouse button over the icon of the corresponding DRT2-series Smart Slave in the Network Configuration Window, and select **Parameters** and **Edit** to display the Edit Device Parameters Window.
3. Click the **General** Tab and select the desired setting from the pull-down menu under the *Default Connection Path* field.

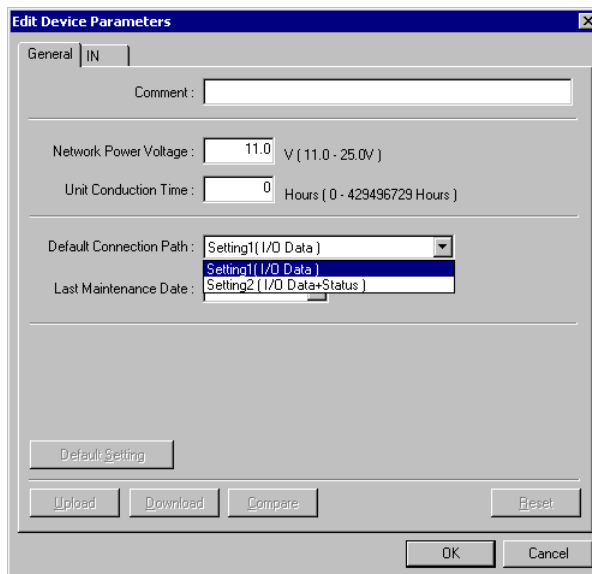

4. Click the **Download** Button and then click the **Reset** Button.
5. Click the **OK** Button.

Default Connection Path (General-purpose Slave)

Selection	IN/OUT	Input Unit	Output Unit	I/O Unit
Setting 1 (I/O Data) (default setting)	IN data	Real input data	None	Real input data
	OUT data	None	Real output data	Real output data
Setting 2 (I/O Data+Status)	IN data	Real I/O data + status information	Status information	Real input data + status information
	OUT data	None	Real output data	Real output data

**Allocating User-defined Data**

This method is possible only with a CS/CJ-series DeviceNet Unit and user-defined allocations.

In the Master's Edit Device Parameters Window, select the Smart Slave to be set, and specify the connection in the Advanced Setting Window. Select the I/O data (pattern) in the connection path setting.

In the Master's Edit Device Parameters Window, allocate Slave I/O.

- Note**
1. For details on connections and connection paths, refer to *Appendix B DeviceNet Connections* in the *DeviceNet Units Operation Manual (W380)*.
  2. Master Unit settings take precedence and so it is not necessary to set the Slave's default connection path.

The setting example below is for allocating 16 inputs, 8 outputs, and Generic Status Flags for a General-purpose Slave. For details on the setting method for Analog Slaves, refer to *7-4-2 I/O Data Allocation Methods*.

**Example: Using 16 inputs, 8 outputs, and status information.**

Address	15	0
CIO 3200	8 outputs	
	:	
CIO 3300	16 inputs	
	:	
CIO 3500	Generic Status Flags	

## Procedure

- 1,2,3... 1. In the Network Configuration Window, select the Master Unit, and double-click or click the right mouse button and select **Parameter – Edit – General**, and then select the Smart Slave to be set.

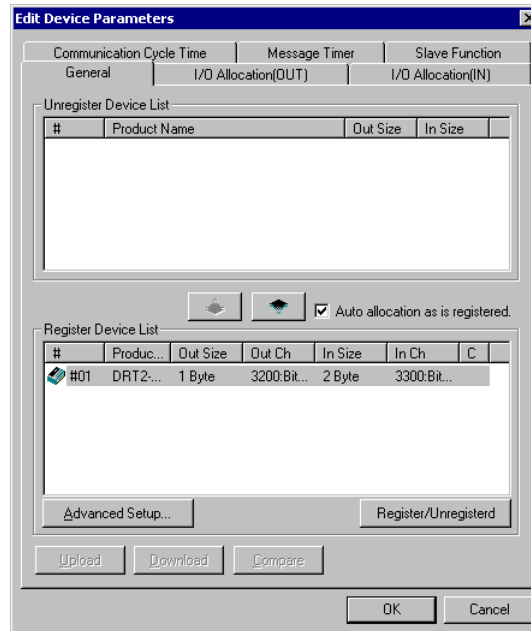

2. Click the **Advanced Setup** Button, click the **Connection** Tab, and select **User Setup**. Select **Use Poll Connection** and **Use COS Connection** and then select **output data**, **input data**, and **generic status** for the respective connection paths. In this example, the IN size for COS connection is set to **generic status**, the IN size for poll connection is set to **input data**, and OUT size for poll connection is set to **output data**.

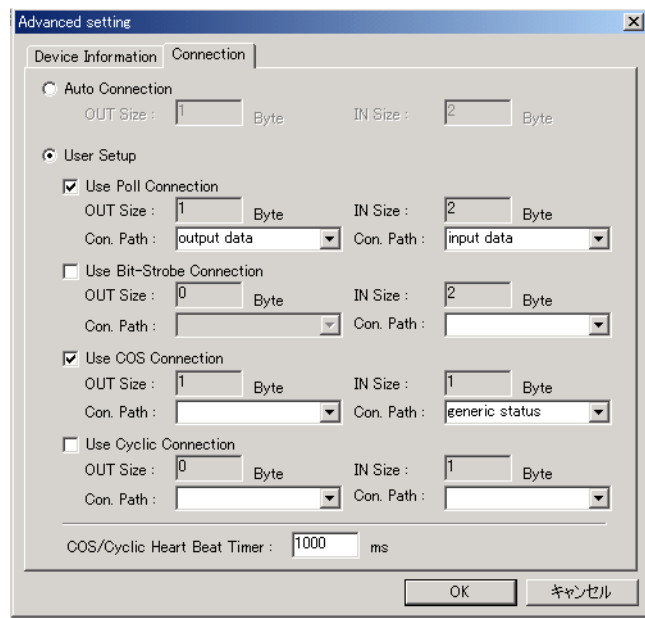

3. Click the **OK** Button.

**Note** If there are checks in the checkboxes but the connection path settings are left blank, the following settings will be made automatically.

	IN (Smart Slave to Master Unit)	OUT (Master Unit to Smart Slave)
Poll	input data	output data
Bit-Strobe	input data	Not set.
COS	generic status	Not set.
Cyclic	generic status	Not set.

**Note** For Slaves with outputs (and consequently output size settings), if the poll and COS connections are used at the same time, the output size settings for poll and COS connections must be set to the same value. Perform this setting with the Configurator using the method below. (The default output size setting for the COS connection is 0.)

Click the right mouse button over the Slave to be set, select **Property**, click the **I/O Information** Tab, and then click the **Edit** Button. In the Edit I/O Size Window, set the **OUT Size** for the poll and COS connections to the same value.

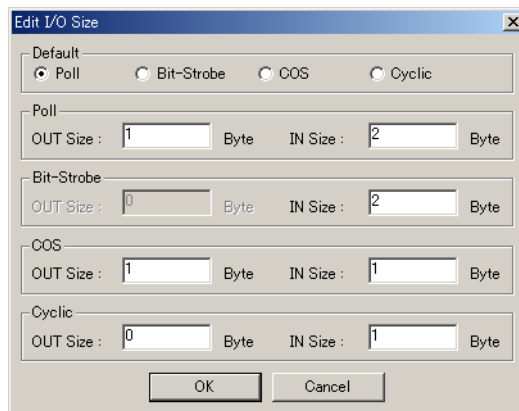

- Click the **I/O Allocation (IN)** Tab and edit the I/O allocations. Select the Smart Slave to be set and click the **Edit** Button to display the Edit I/O Allocate Window. Set the *Poll* settings (indicates input data) to block 1, allocated 3300. Set the *COS* settings (indicates generic data) to block 2, allocated 3500.

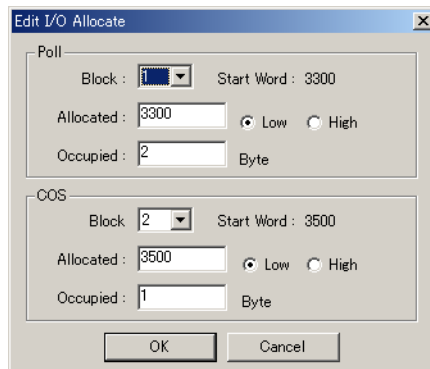

5. Click the **OK** Button.

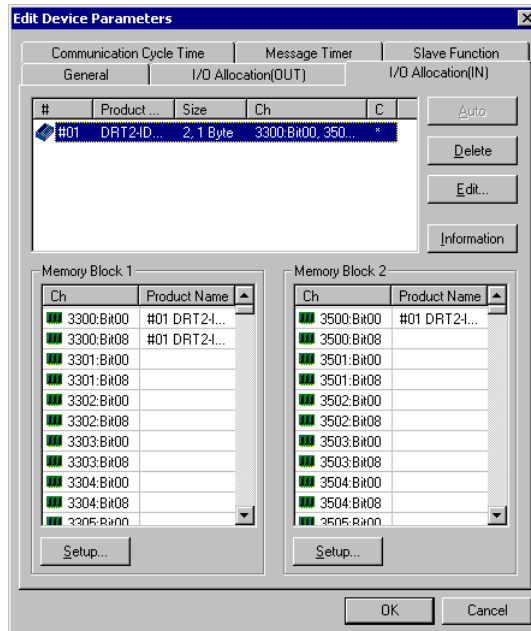

6. In the same way as above, click the **I/O Allocation (OUT)** Tab and edit the I/O allocations. Set to block 1, allocated 3200.

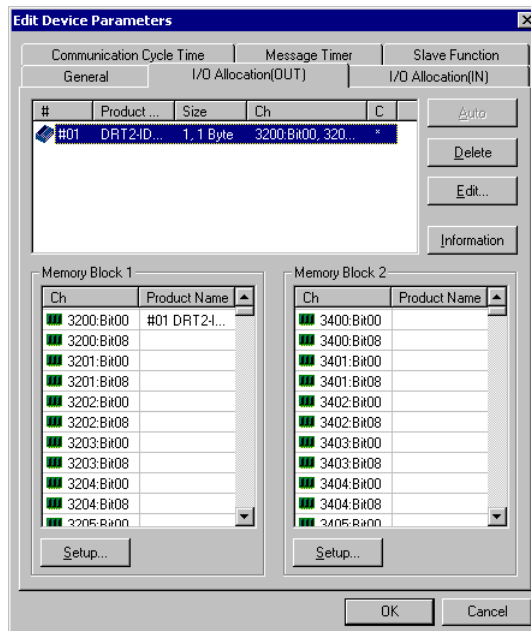

7. Return to the General Tab Page and click **Download**.

**Note** When *Auto allocation as is registered.* is selected in the General Tab Page, each time the connection path is set, a message will be displayed indicating that the current I/O allocations have been deleted because the connection has been changed. To set the connection path, deselect *Auto allocation as is registered.* before registering the Slaves.

# SECTION 4

## Functions of All Slaves, General-purpose Slaves, and Environment-resistive Slaves

This section describes the functions of DRT2-series Smart Slaves and their applications, including operation procedures using a DeviceNet Configurator.

4-1	Maintenance Mode Window and Main Window .....	48
4-1-1	Normal Window .....	48
4-1-2	Maintenance Mode Window .....	49
4-1-3	Device Monitor Window .....	51
4-2	Common Slave Functions .....	52
4-2-1	Automatic Baud Rate Recognition .....	52
4-2-2	Network Power Supply Voltage Monitor .....	53
4-2-3	Unit Conduction Time Monitor .....	54
4-2-4	Slave Comments .....	55
4-2-5	I/O Comments .....	57
4-2-6	Communications Error History Monitor .....	59
4-2-7	Last Maintenance Date .....	60
4-3	Functions of General-purpose Slaves and Environment-resistive Slaves .....	61
4-3-1	I/O Power Status Monitor .....	61
4-3-2	Input Filter .....	62
4-3-3	Power ON Delay .....	64
4-3-4	Contact Operation Counter .....	64
4-3-5	Total ON Time Monitor .....	66
4-3-6	Operation Time Monitor .....	68
4-3-7	Sensor Disconnected Detection .....	72
4-3-8	Detection of Sensor Power Short-circuit .....	74
4-3-9	External Load Short-circuit Detection .....	76
4-3-10	External Load Disconnected Detection .....	80



## 4-1 Maintenance Mode Window and Main Window

The OMRON DeviceNet Configurator (Ver. 2.20 or higher) is provided with two Network display windows, consisting of the standard Main Window and a Maintenance Mode Window. The windows can be easily switched by clicking the  icon or selecting maintenance mode under the View Menu.

### 4-1-1 Normal Window

The Normal Window is displayed when the DeviceNet Configurator is started. It has a white background. Normally this window is used to set parameters and other settings. Double-click any Slave in the Normal Window to enable setting and editing device parameters for the Slave. Refer to *4-2 Common Slave Functions* for information on setting and editing Slave functions. Also refer to the setting methods for the functions listed for each Slave.

### Normal Window

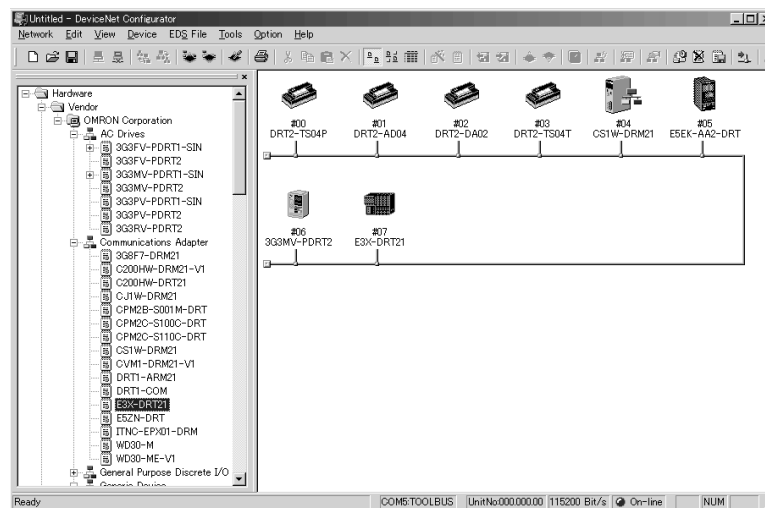

### Device Parameter Editing Window

This window is used to set and edit settings for functions. Double-click any Slave or select the slave, right-click, and select **Parameter - Edit** from the popup menu.

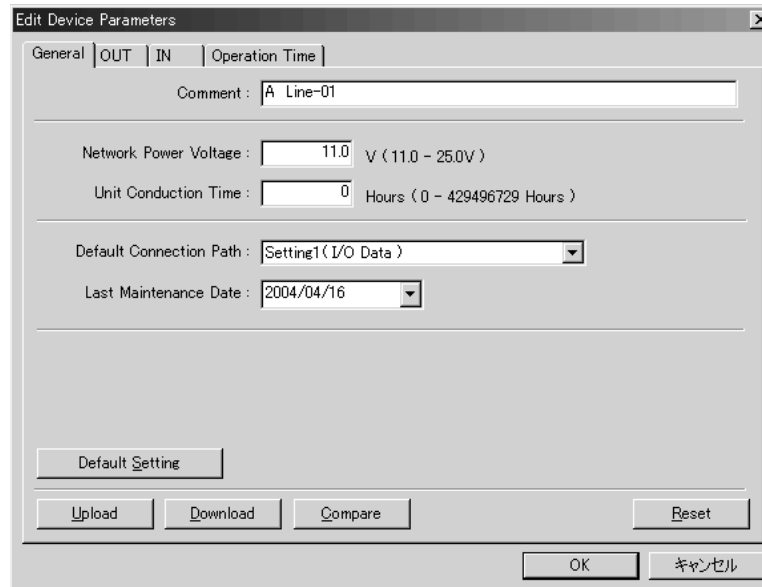

### 4-1-2 Maintenance Mode Window

The Maintenance Mode Window is different from the Main Window and is used to easily monitor information on the DRT2-series Smart Slaves. The windows can be easily switched by clicking the  icon or selecting maintenance mode under the View Menu. The Maintenance Mode Window is displayed with a pale blue background.

The Maintenance Mode Window displays information on the DRT2-series Smart Slaves in the Maintenance Information Window. Open the Maintenance Mode Window when to access status information on any of the Smart Slaves.

In the Network Configuration Window, when an error is detected in any of the Slaves' settings, a yellow warning icon indicating the error details will be displayed next to the corresponding Slave icon. This function allows the user to know the status of each device, the maintenance period, and the location where an error has been detected.

**Note** The Maintenance Mode Window is not refreshed continuously. The status that is display is read when the network is uploaded. To see the most recent status, click the refresh maintenance information icon to read the current status information, or use the Device Monitor Window to see continuously updated Smart Slave status. (Refer to 4-1-3 Device Monitor Window.)

**Maintenance Mode Window**

Refresh maintenance information icon  
Rereads the current maintenance information.

Warning icon  
Maintenance Information Window

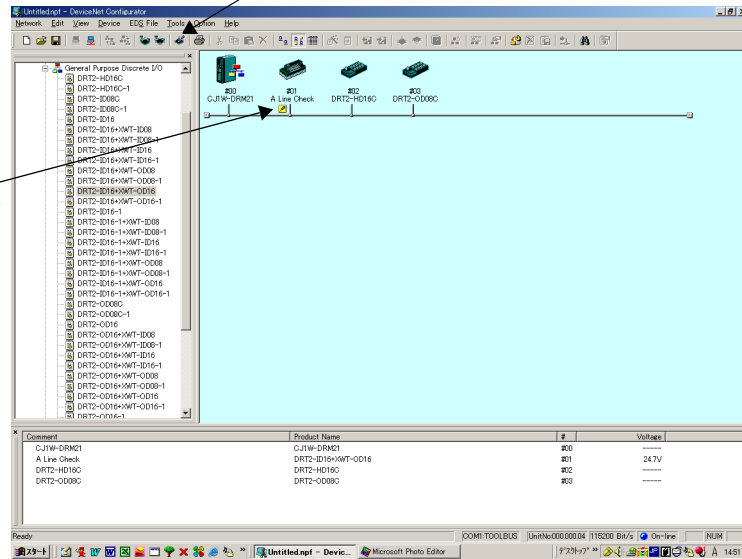

**Maintenance Information Window**

Double-click the icon of the DRT2-series Smart Slave that is indicated by the warning icon to display the Maintenance Information Window for the individual Slave. Refer to the section on the Maintenance Information Window for each Slave for details on the information that is displayed.

Refreshes the maintenance information for the current Slave.

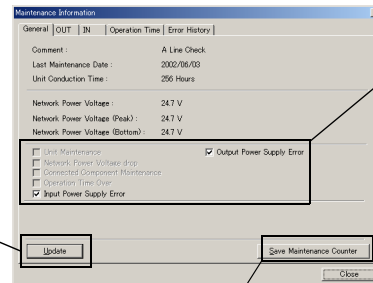

Maintenance information  
Refreshes the maintenance information for the current Slave.

The Smart Slave's maintenance counter can be saved in flash memory. Normally, the contact operation counter records the value every six minutes, so the number of operations may not be recorded accurately, depending on when the contact's power is turned OFF.

**OUT Tab and IN Tab**

According to the maintenance information, select the **OUT** Tab, **IN** Tab, or **Operation Time** Tab to view more detailed information.

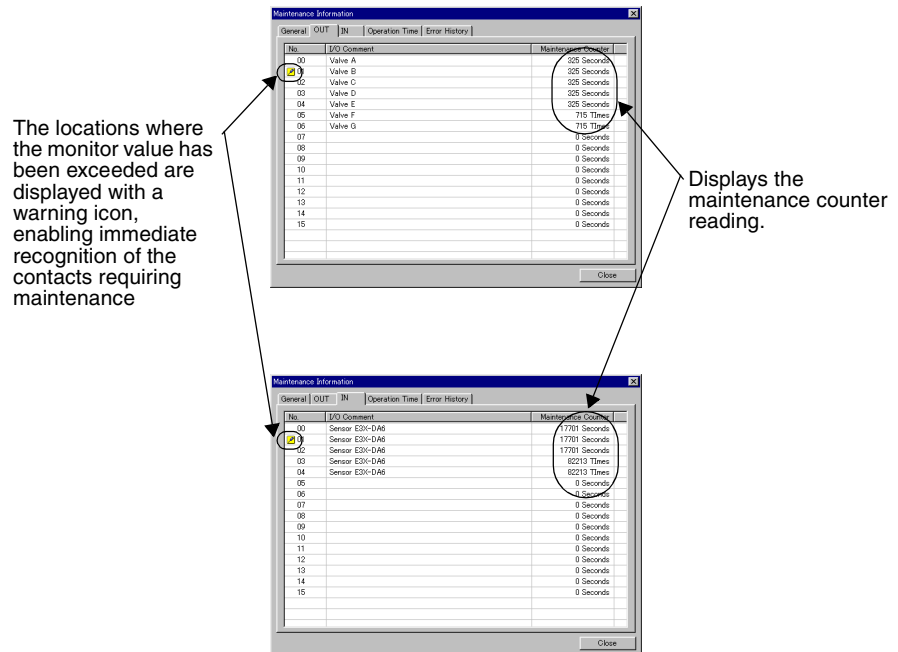

**4-1-3 Device Monitor Window**

The Device Monitor Window enables easy monitoring of information on Smart Slaves. The same information is displayed as for the Maintenance Mode Window, but the displayed information is continuously updated online between the Slave and Configurator by explicit messages. Continuous updating is not performed for the Maintenance Mode Window. Use the Device Monitor Window whenever it is necessary to check the most recent Smart Slave information.

The Device Monitor Window can be displayed when the Configurator is online by right-clicking and selecting **Monitor** from the popup menu. Refer to the section on the Maintenance Information Window for each Slave for details on the information that is displayed.

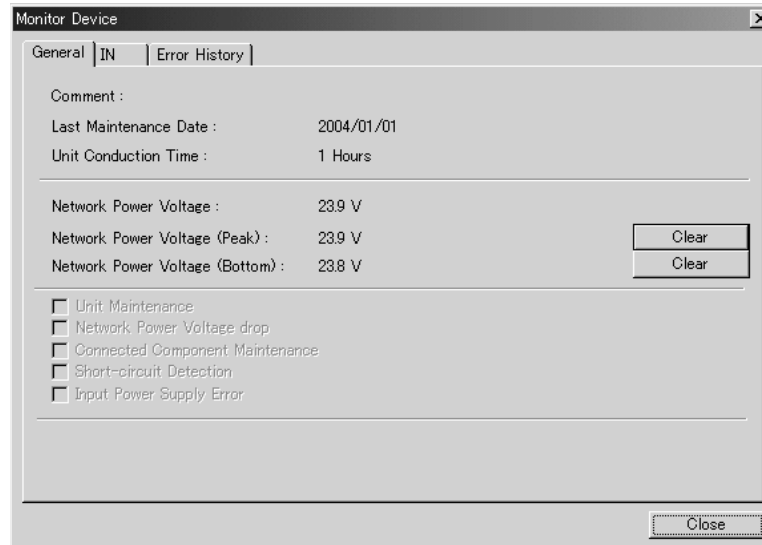
**Device Monitor Window**

**Note** Large quantities of data are exchanged between the Slave and Configurator to enable the device monitor function. If a toolbus connection is used for the Configurator, the time required to refresh all of the information depends on the Slave and can be very long. We thus recommend using a DeviceNet Board (PCMCIA, PCI, or ISA) to connect the Configurator whenever using the device monitor function. Refer to *Section 2 Installation* in the *DeviceNet Configurator Operation Manual* (Cat. No. W382) for details.

A toolbus connection is used when a CS1W-DRM21 or CJ1W-DRM21 Master Unit is used and the Configurator is connected via RS-232C.

**4-2 Common Slave Functions**

The functions common to all DRT2-series Slaves and their usage procedures are described here.

**4-2-1 Automatic Baud Rate Recognition**

The Smart Slaves are automatically set to the baud rate of the Master Unit. Therefore, the baud rate does not require being set for each Unit using the DIP switch as with previous models.

After the power is turned ON, as soon as communications are established with the Master Unit, the baud rate is set, and the setting is saved until the next time the power is turned ON.

**Note** When changing the baud rate of the Master Unit, always turn the Slave's Network power supply OFF and ON again.

The Slave's baud rate will be automatically set to the Configurator's baud rate when the Configurator is used to set a Smart Slave when there is no Master. To change the baud rate, turn the Smart Slave's Network power supply OFF and ON again.

## 4-2-2 Network Power Supply Voltage Monitor

### Function Overview

The present, bottom, and peak values of the Network power voltage can be recorded in the Slave. The monitor voltage (factory setting: 11 V) can be maintained in the Slave and the Network Power Voltage Error Flag in the Status Area will be turned ON when the voltage drops below the set monitor value. The current, minimum, and maximum values of the Network power voltage, and the Network Power Voltage Error Flag can be read from the Configurator. The monitor voltage can be set using the Configurator.

- Note**
1. The communications power voltage of the actual DeviceNet is 11 V minimum, so if the communications power voltage drops below 11 V, the operation for reading the measurement values using the Configurator may not function properly.
  2. The maximum and minimum Network power voltages are cleared when the Network power is turned OFF.

### Setting Using the DeviceNet Configurator

The method used to set values from the DeviceNet Configurator (Ver. 2.20 or later) is described here.

- 1,2,3... 1. Turn ON the power to the DRT2-series Smart Slave.
2. From the Main Window, open the Network Configuration Window and double-click or click the right mouse button over the icon of the DRT2-series Smart Slave to be set. Select **Parameter** and **Edit** to display the Edit Device Parameters Window.  
From the Maintenance Mode Window, click the right mouse button over the icon of the DRT2-series Smart Slave to be set. Select **Parameter** and **Edit** to display the Edit Device Parameters Window.
3. Select the **General** Tab.

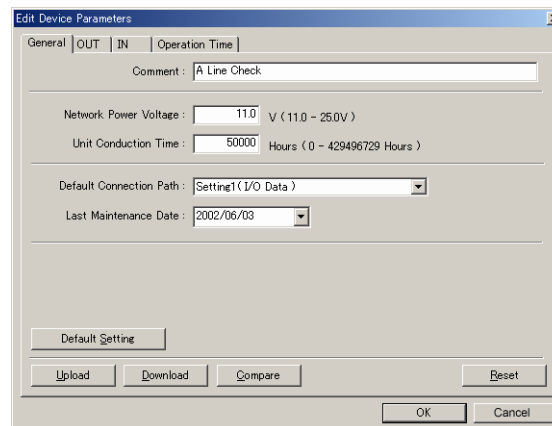

4. Enter the desired value in the *Network Power Voltage* field. (The default value is 11 V.)
5. Click the **Download** Button, and then click the **Reset** Button to reset the Unit.
6. Click the **OK** Button.

### 4-2-3 Unit Conduction Time Monitor

#### Function Overview

The total ON time (unit: 0.1 hrs) of the Slave's internal circuit power can be calculated and recorded. (The Configurator or explicit messages can be used to read the information.)

The monitor value can be maintained in the Slave and the Unit Maintenance Flag in the Status Area will be turned ON when the total time reaches the set monitor value. The total ON time can be read using the Configurator or explicit messages.)

- Measured time: 0 to 429496729 hours (stored data: 00000000 to FFFFFFFF Hex)
- Measuring unit: 0.1 hr

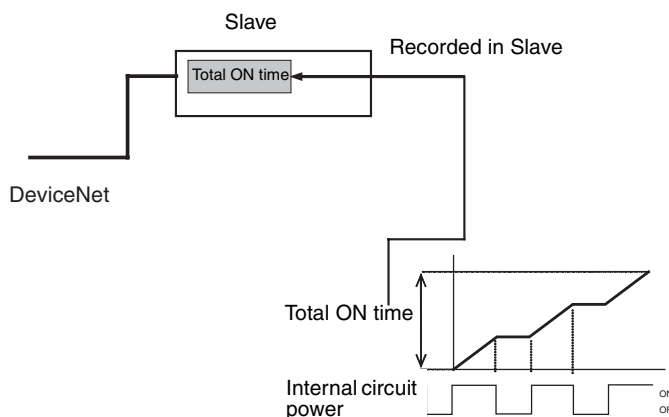

**Note** The Unit conduction time monitor calculates the total time that the Smart Slave's Network power supply is ON. The total time is not calculated when the power is OFF.

#### Setting Using the DeviceNet Configurator

The method used to set values from the DeviceNet Configurator (Ver. 2.20 or later) is described here.

- 1,2,3...**
1. Turn ON the power to the DRT2-series Smart Slave.
  2. From the Main Window, open the Network Configuration Window and double-click or click the right mouse button over the icon of the DRT2-series Smart Slave to be set. Select **Parameter** and **Edit** to display the Edit Device Parameters Window.  
From the Maintenance Mode Window, click the right mouse button over the icon of the DRT2-series Smart Slave to be set. Select **Parameter** and **Edit** to display the Edit Device Parameters Window.

3. Select the **General** Tab.

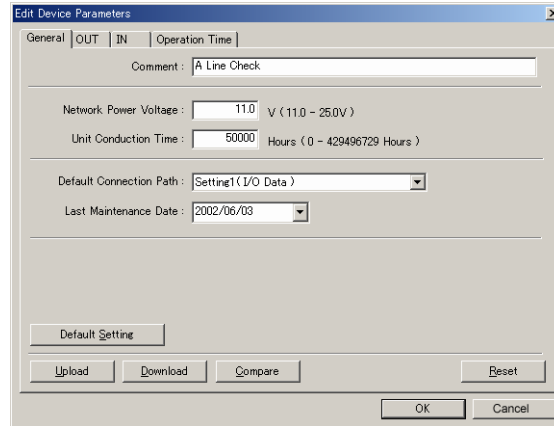

4. Enter the desired value in the *Unit Conduction Time* field.
5. Click the **Download** Button, and then click the **Reset** Button to reset the Unit.
6. Click the **OK** Button.

### 4-2-4 Slave Comments

#### Function Overview

The user can assign and record a name or comment for every Unit (up to 32 characters). The Configurator or explicit messages can be used to read and write these Unit names (comments).

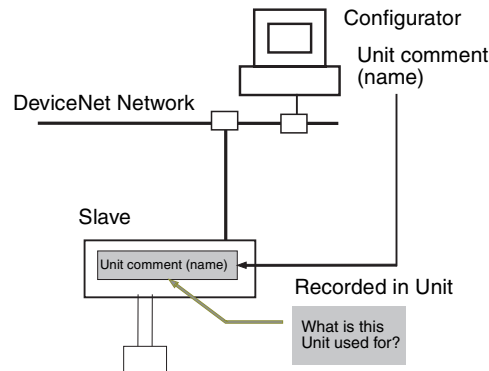

#### Setting Using the DeviceNet Configurator

The method used to set values from the DeviceNet Configurator (Ver. 2.20 or later) is described here.

Either of the following two settings methods can be used.

##### Setting Method 1

1,2,3...

1. Turn ON the power to the DRT2-series Smart Slave.
2. From the Main Window, open the Network Configuration Window and double-click or click the right mouse button over the icon of the DRT2-series Smart Slave to be set. Select **Parameter** and **Edit** to display the Edit Device Parameters Window.  
From the Maintenance Mode Window, click the right mouse button over the icon of the DRT2-series Smart Slave to be set. Select **Parameter** and **Edit** to display the Edit Device Parameters Window.



3. Select the **General** Tab.

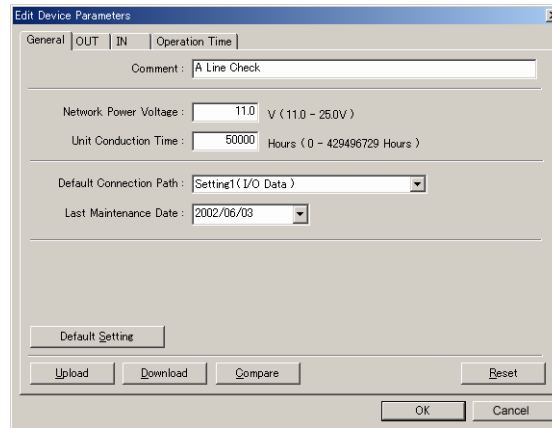

4. Enter the desired name in the *Comment* field.
5. Click the **Download** Button, and then click the **Reset** Button to reset the Unit.
6. Click the **OK** Button.

Setting Method 2

The procedure for this setting method is the same from both the Main Window and the Maintenance Mode Window.

1,2,3...

1. Turn ON the power to the DRT2-series Smart Slave.
2. Click the right mouse button over the icon of the DRT2-series Smart Slave to be set in the Network Configuration Window, and select **Change Device Comment**.

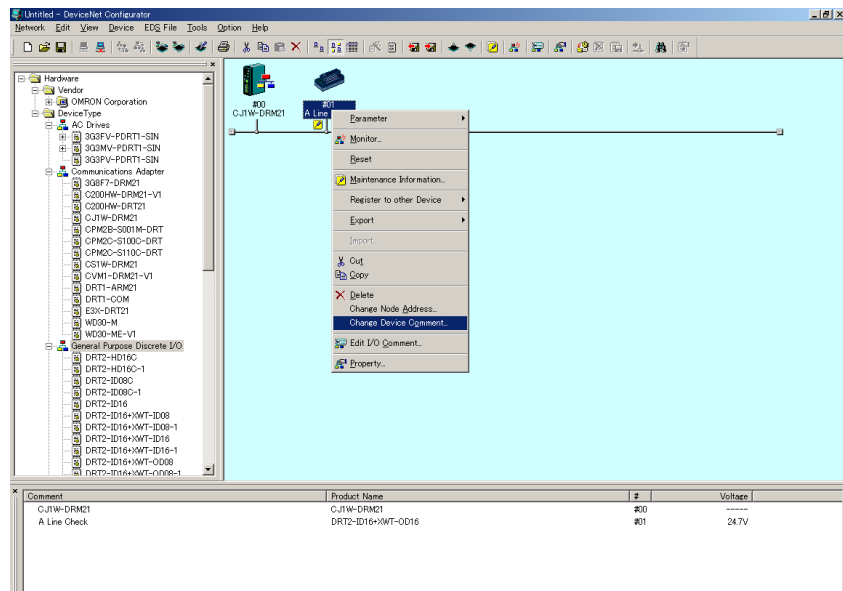

3. The following window will be displayed. Enter the desired name.

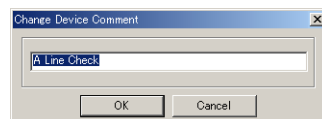

4. Click the **OK** Button.
5. Click the right mouse button over the icon of the DRT2-series Smart Slave to be set, and select **Parameter** and **Download**.

### 4-2-5 I/O Comments

#### Function Overview

The user can assign a name for each of the Unit's I/O contacts (up to 32 characters) and record it in the Unit. The connected device can be checked for each I/O contact, allowing faulty devices to be identified during remote maintenance. The Configurator or explicit messages can be used to read and write the names (comments) of the connected devices.

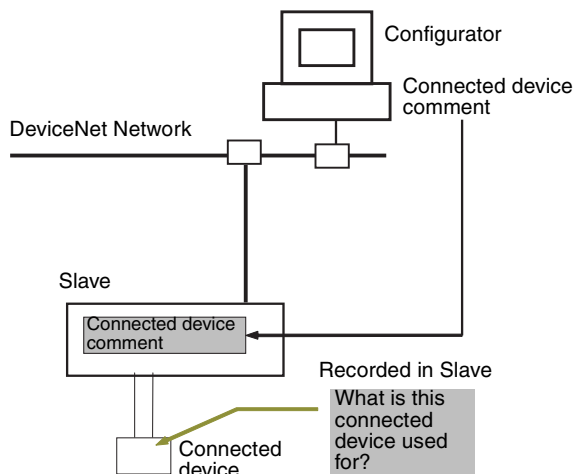

#### Setting Using the DeviceNet Configurator

Either of the following two setting methods can be used.

##### Setting Method 1

1,2,3...

1. Turn ON the power to the DRT2-series Smart Slave.
2. From the Main Window, open the Network Configuration Window and double-click or click the right mouse button over the icon of the DRT2-series Smart Slave to be set. Select **Parameter** and **Edit** to display the Edit Device Parameters Window.  
From the Maintenance Mode Window, double-click or click the right mouse button over the icon of the DRT2-series Smart Slave to be set. Select **Parameter** and **Edit** to display the Edit Device Parameters Window.
3. Select the **IN** or **OUT** Tab. The following window will be displayed. Enter the desired name.

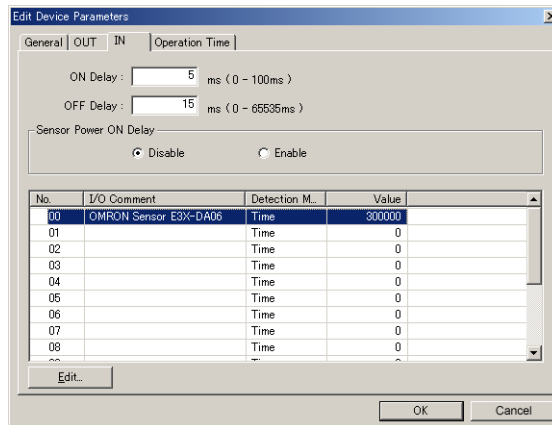

4. Double-click the **I/O Comment** field for the connected device that is to be assigned a name (comment). The following window will be displayed. Enter the desired name and click the **OK** Button.

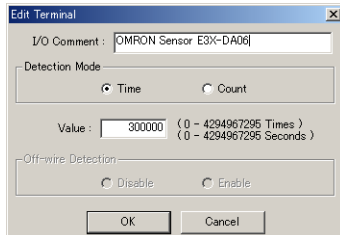

5. Select the **General** Tab, click the **Download** Button, and then click the **Reset** Button to reset the Unit.
6. Click the **OK** Button.

**Setting Method 2**

The procedure for this setting method is the same from both the Main Window and the Maintenance Mode Window.

1,2,3...

1. Turn ON the power to the DRT2-series Smart Slave.
2. Double-click or click the right mouse button over the icon of the DRT2-series Smart Slave to be set in the Network Configuration Window, and select **Edit I/O Comment**.

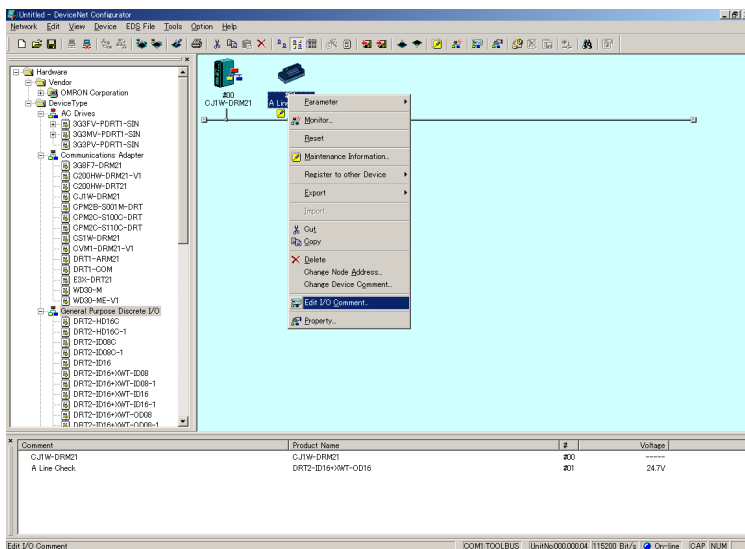

3. The following type of window will be displayed. Select the terminal which is to have a name (comment) assigned.

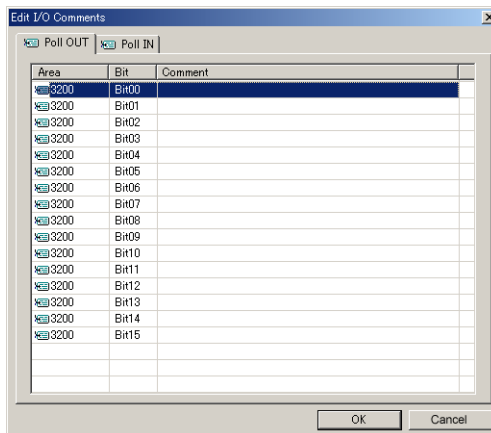

**Note** With Analog Terminals, comments input using setting method 1 are not automatically reflected in this window. Before saving the comments to an I/O comment file, make the settings using setting method 2.

4. Double-click the **Comment** field of the terminal to be set and enter the desired name.

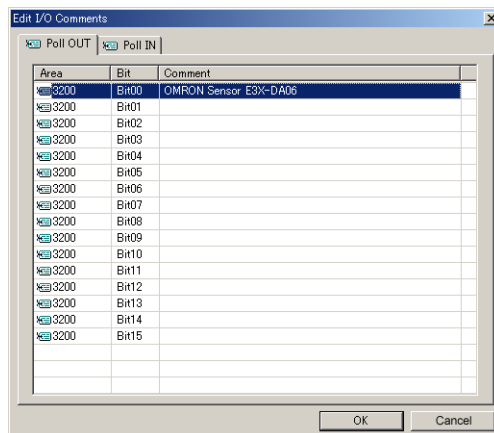

5. Click the **OK** Button.
6. Double-click or click the right mouse button over the icon of the DRT2-series Smart Slave to be set, and select **Parameter** and **Download**.

## 4-2-6 Communications Error History Monitor

### Function Overview

The error status information (communications error code, communications power voltage when the error occurred) for the last four communications errors that occurred can be recorded in the Slave.

(The Configurator can be used to read the communications error history.)

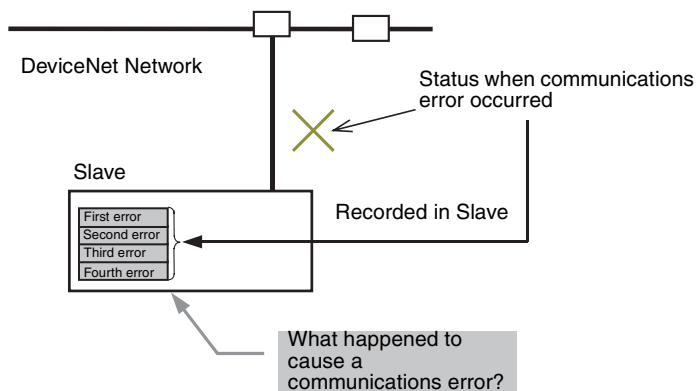

**Checking Using the DeviceNet Configurator**

The method used to check error information from the DeviceNet Configurator (Ver. 2.20 or later) is described here.

1,2,3...

1. Turn ON the power to the DRT2-series Smart Slave.
2. Click the right mouse button over the icon of the DRT2-series Smart Slave to be set in the Network Configuration Window, and select **Monitor**.

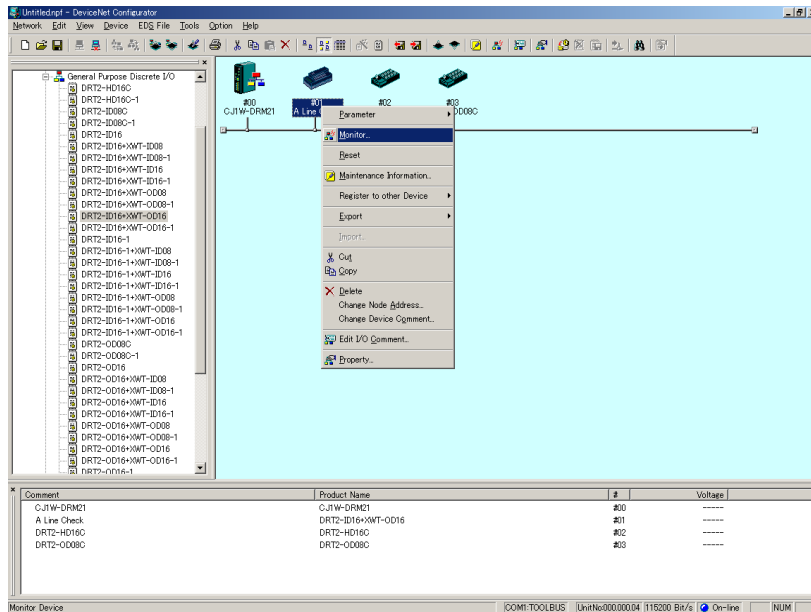

3. Select the **Error History** Tab in the Monitor Device Window. The communications error history for the last four errors that occurred will be displayed, as shown in the following window. To display the most recent error history, click the **Update** Button.

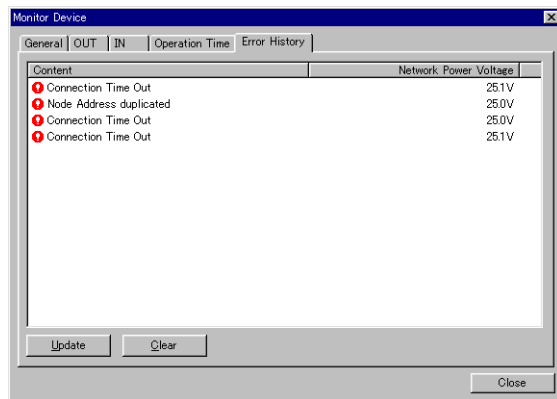

**Note** From the Maintenance Mode Window, double-click the Slave icon, and select the **Error History** Tab from the Maintenance Information Window.

**4-2-7 Last Maintenance Date**

**Function Overview**

This function enables the date on which maintenance was last performed to be written to the Unit. This means that the timing for future maintenance can be judged more easily. The date can be written using the Configurator.

### Setting Using the DeviceNet Configurator

- 1,2,3...
1. From the Main Window, double-click the icon of the Smart Slave to be set to display the Edit Device Parameters Window. (From the Maintenance Mode Window, click the right mouse button over the icon of the Smart Slave to be set and select **Parameter** and **Edit** to display the Edit Device Parameters Window.)
  2. Click the **General** Tab, and select the desired date from the pull-down menu for the *Last Maintenance Date* field. (Click the **Today** Button to enter the current date.)

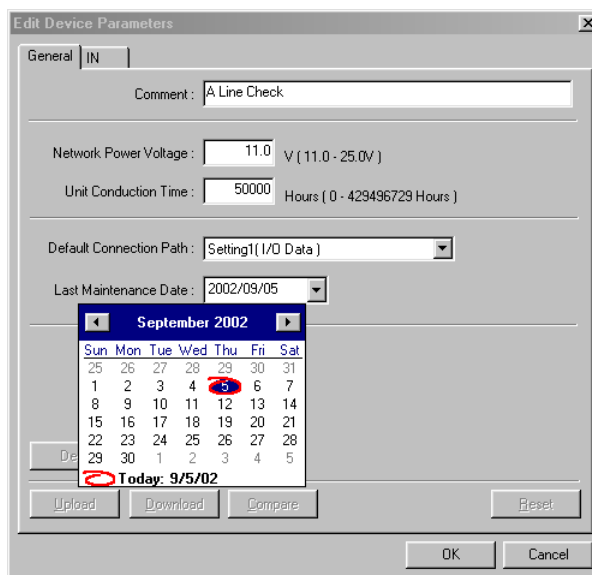

3. Click the **Download** Button, and then click the **Reset** Button to reset the Unit.
4. Click the **OK** Button.

## 4-3 Functions of General-purpose Slaves and Environment-resistive Slaves

### 4-3-1 I/O Power Status Monitor

#### Function Overview

This function is used to detect whether the I/O power is ON. When the I/O power supply is turned OFF, the Basic Unit I/O Power Voltage Status Flag or Expansion Unit I/O Power Status Flag in the Status Area is turned ON. (The Configurator or explicit messages can be used to read the information.)

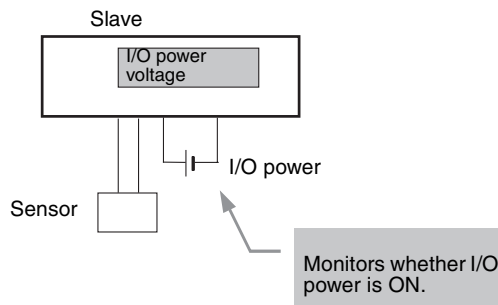

**Note** The value for detecting a low voltage for the I/O power cannot be set.

**Checking Using the DeviceNet Configurator**

The method used to check information from the DeviceNet Configurator (Ver. 2.20 or later) is described here.

1,2,3...

1. Turn ON the power to the DRT2-series Smart Slave.
2. From the Maintenance Mode Window, double-click the icon of the applicable DRT2-series Smart Slave in the Network Configuration Window to display the Maintenance Information Window. The I/O power is not being supplied if the *Input Power Supply Error* or *Output Power Supply Error* items are selected.

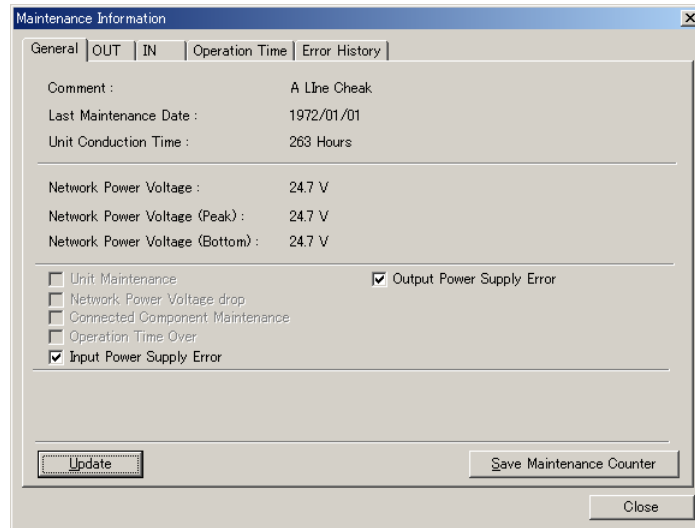

**4-3-2 Input Filter**

**Function Overview**

Input values can be read several times during a set interval so that the input value is enabled only when the value of all samples are the same. The input filter is applied to all of the inputs of the Unit.

**ON Response Time (Variable from 0 to 100 ms)**

When input data changes to ON, the input data is read four times for the period of the set interval (1/4 of 0 to 100 ms). If all values are ON, the input is turned ON. The ON timing is delayed according to the length of the ON response time.

The input filter can also be used to perform an ON delay operation (a delay for the ON response time is created when the input filter is enabled).

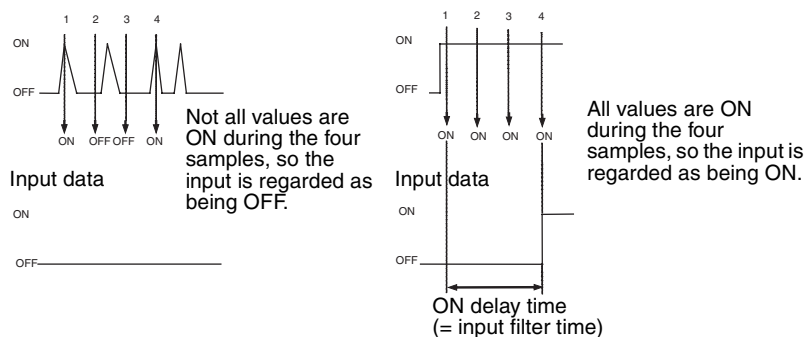

**OFF Response Time  
(Variable from 0 to  
65535 ms)**

When input data changes to OFF, the input data is read five times for the period of the set interval (1/5 of 0 to 65,535 ms). If all values are OFF, the input is turned OFF. The OFF timing is delayed according to the length of the OFF response time.

The input filter can also be used for ON/OFF delay operations.

To use a pulse shorter than the communications cycle time, set the OFF response time to a value longer than the communications cycle time. (If the input pulse is short, the input may remain ON.)

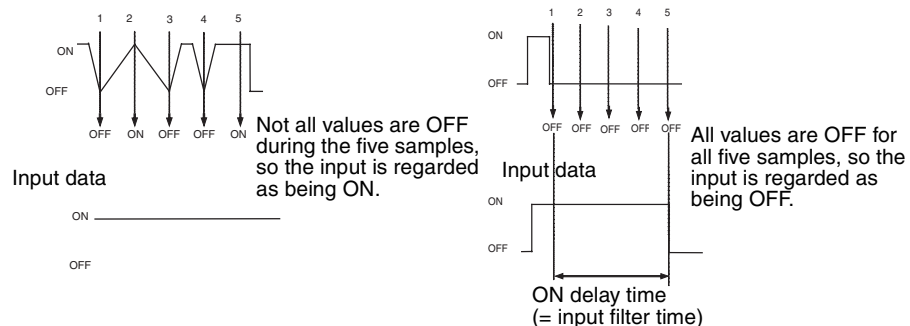

**Setting Using the  
DeviceNet  
Configurator**

The method used to set values from the DeviceNet Configurator (Ver. 2.20 or later) is described here.

1,2,3...

1. Turn ON the power to the DRT2-series Smart Slave.
2. From the Main Window, open the Network Configuration Window and double-click or click the right mouse button over the icon of the DRT2-series Smart Slave to be set. Select **Parameter** and **Edit** to display the Edit Device Parameters Window.  
From the Maintenance Mode Window, click the right mouse button over the icon of the DRT2-series Smart Slave to be set. Select **Parameter** and **Edit** to display the Edit Device Parameters Window.
3. Select the **IN** Tab.  
Enter a value for the ON response time and OFF response time, and then click the **OK** Button.

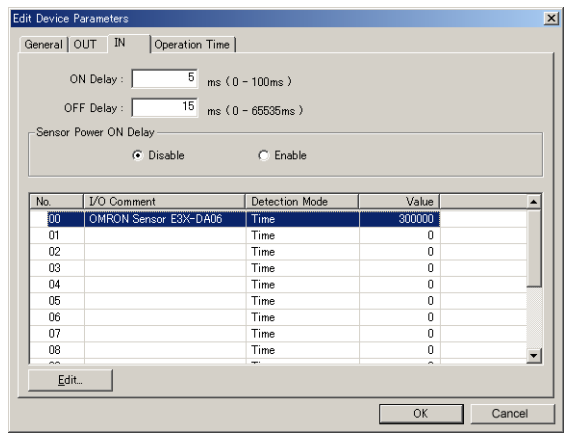

4. Select the **General** Tab, click the **Download** Button, and then click the **Reset** Button to reset the Unit.
5. Click the **OK** Button.



### 4-3-3 Power ON Delay

#### Function Overview

The I/O power is monitored, and input is stopped when the I/O power is OFF and for 100 ms after the I/O power is turned ON (i.e., until the power supply becomes stable). This function prevents incorrect input caused by inrush current at startup from connected devices when the I/O power is turned ON. The Configurator or explicit messages can be used to enable or disable this function.

#### Setting Using the DeviceNet Configurator

The method used to set values from the DeviceNet Configurator (Ver. 2.20 or later) is described here.

1,2,3...

1. Turn ON the power to the DRT2-series Smart Slave.
2. From the Main Window, open the Network Configuration Window and double-click or click the right mouse button over the icon of the DRT2-series Smart Slave to be set. Select **Parameter** and **Edit** to display the Edit Device Parameters Window.  
From the Maintenance Mode Window, click the right mouse button over the icon of the DRT2-series Smart Slave to be set. Select **Parameter** and **Edit** to display the Edit Device Parameters Window.
3. Select the **IN** Tab.  
Select **Enable** under the item for preventing malfunctions caused by inrush current at startup and click the **OK** Button.

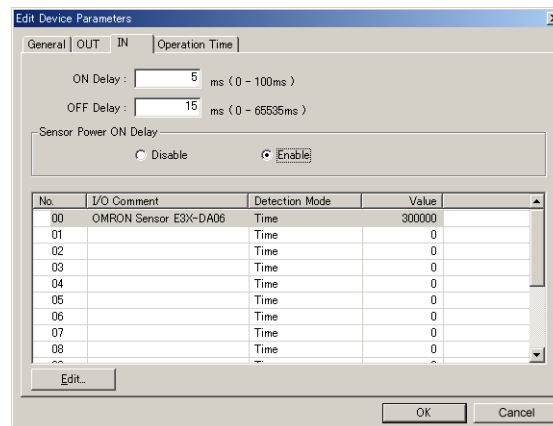

4. Select the **General** Tab, click the **Download** Button, and then click the **Reset** Button to reset the Unit.
5. Click the **OK** Button.

### 4-3-4 Contact Operation Counter

#### Function Overview

The Contact Operation Counter is used to count the number of times each input or output contact is changed from OFF to ON (maximum resolution 50 Hz) and record the total value calculated in the Slave. (The Configurator or explicit messages can be used to read the information.)

The monitor value can be set in the Slave, and when the set number of operations is reached, the Connected Component Maintenance Flag in the Status Area will be turned ON. (The Configurator or explicit messages can be used to read the status of the Connected Device Maintenance Flag.)

- Counted operations: 0 to 4294967295 operations (stored data: 00000000 to FFFFFFFF Hex)

- Counting unit: One operation

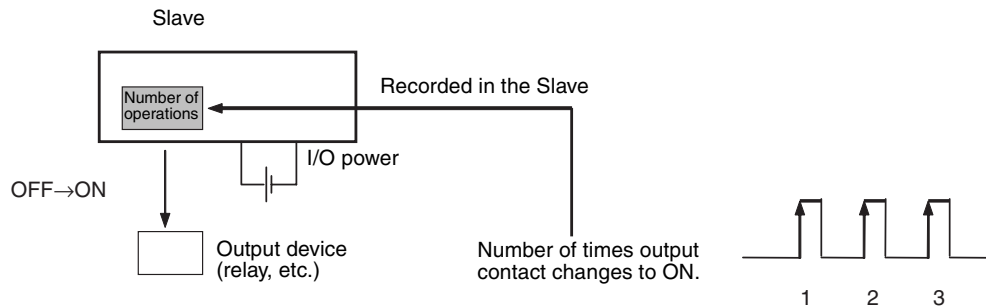

- Note**
- The Contact Operation Counter and Total ON Time Monitor cannot be used at the same time for a single contact. Select the function to be used under the *Detection Mode* heading.
  - The Contact Operation Counter will operate when the I/O power is ON only.

### Setting Using the DeviceNet Configurator

The method used to set values from the DeviceNet Configurator (Ver. 2.20 or later) is described here.

- Turn ON the power to the DRT2-series Smart Slave.
- From the Main Window, open the Network Configuration Window and double-click or click the right mouse button over the icon of the DRT2-series Smart Slave to be set. Select **Parameter** and **Edit** to display the Edit Device Parameters Window.  
From the Maintenance Mode Window, click the right mouse button over the icon of the DRT2-series Smart Slave to be set. Select **Parameter** and **Edit** to display the Edit Device Parameters Window.
- Select the **IN** Tab.

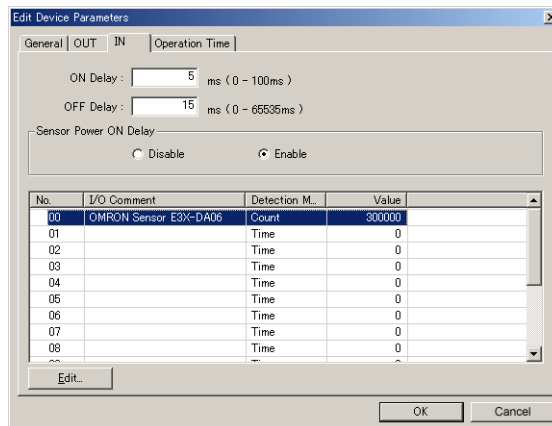

- Double-click the **I/O Comment** field of the applicable contact to display the following window. Select *Count* under *Detection Mode*, enter a value in the

Value field, and then click the **OK** Button.

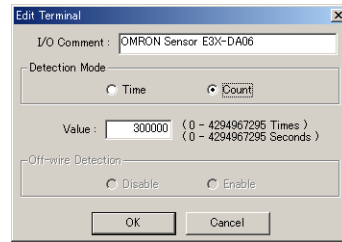

5. After checking that the setting for the monitor value is reflected in the Edit Device Parameters Window, select the **General** Tab and click the **Download** Button.
6. Click the **OK** Button.

### 4-3-5 Total ON Time Monitor

#### Function Overview

The total ON time for each I/O contact can be calculated (unit: s) and recorded in the Slave. (The Configurator or explicit messages can be used to read the information.)

The monitor value can be set in the Slave, and when the set number of operations is reached, the Connected Component Maintenance Flag in the Status Area is turned ON. (The Configurator or explicit messages can be used to read the status of the Connected Component Maintenance Flag.)

- Measured time: 0 to 4294967295 s (stored data: 00000000 to FFFFFFFF Hex)
- Measuring unit: s

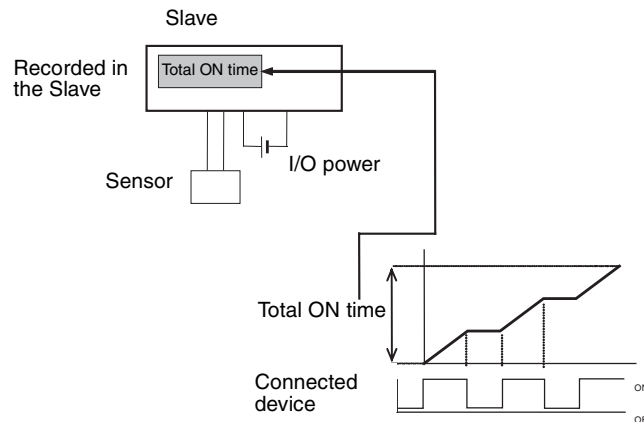

- Note**
1. The Total ON Time Monitor and Contact Operation Counter cannot be used at the same time for a single contact. Select the function to be used under the *Detection Mode* heading.
  2. The Total ON Time Monitor operates when the I/O power is ON only.
  3. The Total ON Time Monitor checks approximately every second whether the connected devices are ON.  
If the total ON time is calculated for ON times of less than a second, the measurement may not be accurate.

■ **Measurement for ON time of 0.5 s:**

In Fig. 1, the actual ON time is  $0.5\text{ s} \times 3 = 1.5\text{ s}$ . The measurement will be taken once during this ON time, so the total ON time will be measured as 1 s.

Reading taken approximately every second.

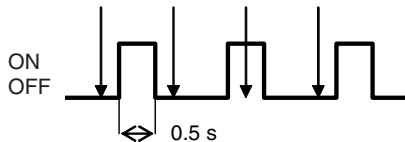

Figure 1

In Fig. 2, the actual ON time is  $0.5\text{ s} \times 3 = 1.5\text{ s}$ . The reading will be taken twice during this ON time, so the total ON time will be measured as 2 s.

Reading taken approximately every second.

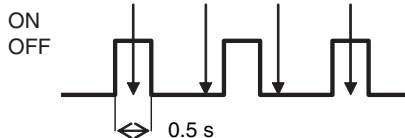

Figure 2

■ **Measurement for ON time of 1.5 s:**

In Fig. 3, the actual ON time is  $1.5\text{ s} \times 2 = 3\text{ s}$ . The measurement will be taken four times during this ON time, so the total ON time will be measured as 4 s.

Reading taken approximately every second.

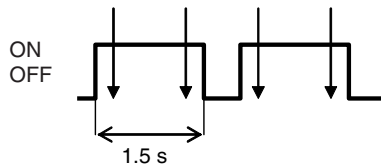

Figure 3

**Setting Using the DeviceNet Configurator**

The method used to set values from the DeviceNet Configurator (Ver. 2.20 or later) is described here.

1,2,3...

1. Turn ON the power to the DRT2-series Smart Slave.
2. From the Main Window, open the Network Configuration Window and double-click or click the right mouse button over the icon of the DRT2-series Smart Slave to be set. Select **Parameter** and **Edit** to display the Edit Device Parameters Window.  
From the Maintenance Mode Window, click the right mouse button over the icon of the DRT2-series Smart Slave to be set. Select **Parameter** and **Edit** to display the Edit Device Parameters Window.

3. Select the **IN** Tab.

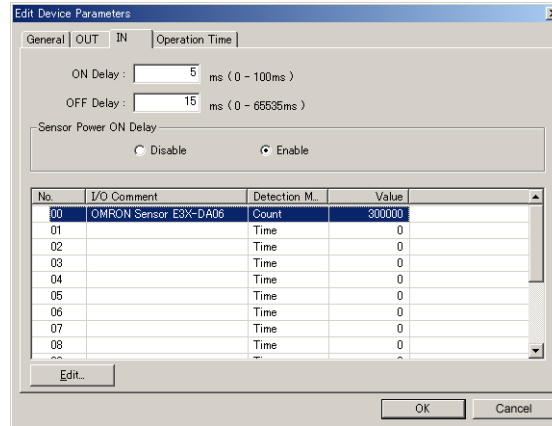

4. Double-click the **I/O Comment** field of the applicable contact to display the following window. Select **Time** under **Detection Mode** and after entering a value in the **Value** field, click the **OK** Button.

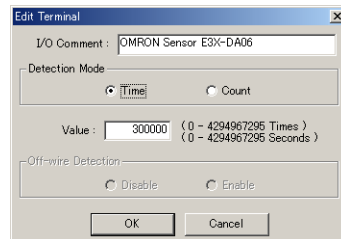

5. After checking that the setting for the monitor value is reflected in the Edit Device Parameters Window, select the **General** Tab and click the **Download** Button.
6. Click the **OK** Button.

### 4-3-6 Operation Time Monitor

#### Function Overview

**Remote I/O Terminal I/O Unit, Basic I/O Unit + Expansion Unit, Sensor Connector I/O Terminal, or Environment-resistive I/O Terminal**

The Operation Time Monitor can measure the time from when the output contact in the Slave changes to ON to when the input contact changes to ON (unit: ms), and records the time in the Slave. (The Configurator or explicit messages can be used to read the information.)

The Operation Time Monitor allows the operating time to be measured precisely without affecting the communications cycle. The monitor value can be set in the Slave, and when the set monitoring time is exceeded, the Operation Time Over Flag in the Status Area will be turned ON.

(The Configurator or explicit messages can be used to read the status of the Operation Time Monitor Flag.)

**Note** This function can be used only by Slaves that have I/O combinations, such as a Basic I/O Unit plus an Expansion Unit. (This function cannot be used with the DRT2-□D08(-1) because an Expansion Unit cannot be connected.) For combinations in which the input and output numbers are the same (e.g., input No. 1 and output No. 1 or input No 8 and output No. 8), it measures the time from when the output turns ON until the input turns ON.

**Three-tier Terminal Block, Environment-resistive Terminal (DRT2-□04CL(-1) Only) MIL Connector Terminal, or Screw-less Clamp Terminal**

The points for measuring the operating time by contact I/O (ON/OFF) timing are the same as for earlier models, but with these Terminals the operating time can be monitored for any combination of contacts (IN-OUT, IN-IN, OUT-OUT) in the Slave.

The trigger edge can be set for either ON to OFF or OFF to ON, and input and output numbers can be freely combined for flexible settings.

**Note** With the I/O-type monitoring function, when the operating time was refreshed the subsequent status might be OFF even if the previous status was ON. With these Terminals, however, the ON status can be retained even when the operating time is refreshed.

- Measured time: 0 to 65535 ms (stored data: 0000 to FFFF Hex)
- Measuring unit: ms

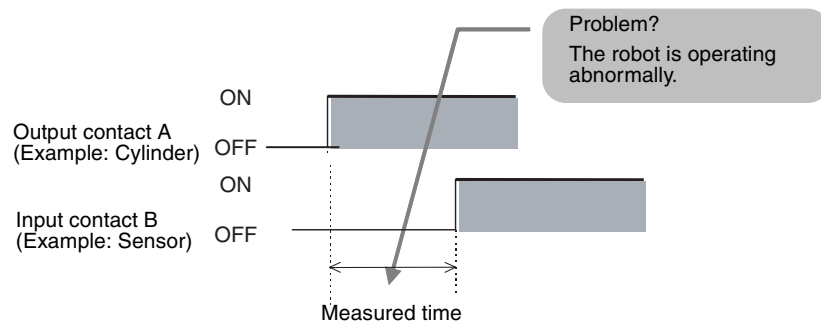
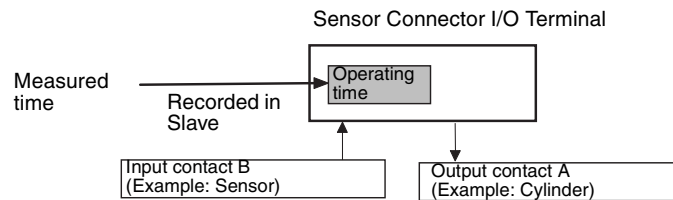

**Note** The precision of the measured time is  $\pm 6$  ms when the ON delay is 0, and the ON delay time is then added. The display resolution for the measured time (ON delay 10 ms:  $\pm 16$  ms), is displayed in 2-ms units when the ON delay is 2 ms or less, and in the measuring unit of the set ON delay time when 3 ms or more. (If the ON delay is 5 ms, the display will be for 5 ms, 10 ms, 15 ms, and 20 ms.)

When using a Basic I/O Unit with an Expansion Unit, Sensor Connector I/O Terminal, or Environment-resistive I/O Terminal, be careful of the following point while making the settings.

- Note**
1. The Operation Time Monitor Flag is refreshed in real time, so even when the set monitor value is exceeded and the Operation Time Monitor Flag is turned ON, the flag will turn OFF without being held if the time from when the next output changes to ON until the input changes to ON is within the set monitor value range.  
To precisely monitor when the monitor value is exceeded, set the flag in-

formation to be held in the ladder program.

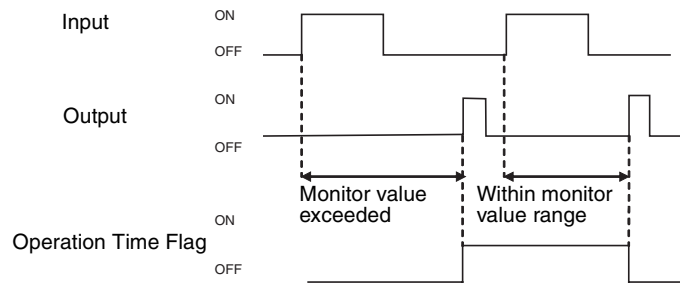

Be careful of the following point when using a Unit that can use the operation time monitor function (i.e., Basic I/O Unit and Expansion Unit, Sensor Connector I/O Terminal, Three-tier Terminal Block, MIL Connector Terminal, or Screw-less Clamp Terminal).

- The operating time is recorded as soon as the time has been measured from when the output changes to ON to when the input changes to ON. The time until the next output changes to ON, however, continues being measured internally, and the measurement value will be refreshed if the input changes to ON again before the next output changes to ON. (When an input occurs during the operation time for a reciprocating operation such as a cylinder, the measurement for the operating time (outward path) may be refreshed during the return time (return path). When an output changes to ON twice consecutively, and is followed by the input changing to ON, the time is measured from when the second output changes to ON until the input changes to ON.

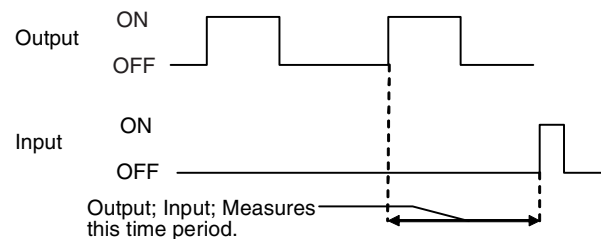
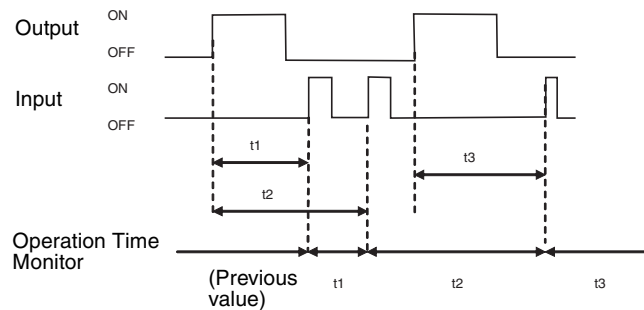

### Setting Using the DeviceNet Configurator

The method used to set values from the DeviceNet Configurator (Ver. 2.20 or later) is described here.

#### Basic I/O Unit Combined with Expansion Unit, Sensor Connector I/O Terminal, or Environment-resistive I/O Terminal

- 1,2,3... 1. Turn ON the power to the DRT2-series Smart Slave.

2. From the Main Window, open the Network Configuration Window and double-click or click the right mouse button over the icon of the DRT2-series Smart Slave to be set. Select **Parameter** and **Edit** to display the Edit Device Parameters Window.

From the Maintenance Mode Window, click the right mouse button over the icon of the DRT2-series Smart Slave to be set. Select **Parameter** and **Edit** to display the Edit Device Parameters Window.

3. Select the **Operation Time** Tab.

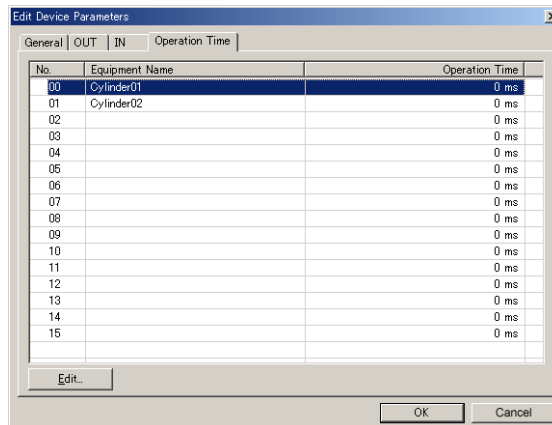

4. Double-click the *Equipment Name* field of the applicable device to display the following window.

Enter the set value in the *Operation Time* field and click the **OK** Button.

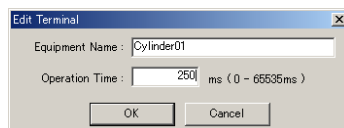

5. Check that the value set in the *Operation Time* field is reflected in the Edit Device Parameters Window. Select the **General** Tab, click the **Download** Button, and then click the **Reset** Button to reset the Unit.
6. Click the **OK** Button.

### Three-tier Terminal Block, MIL Connector Terminal, Screw-less Clamp Terminal

- 1,2,3... 1. Turn ON the power to the DRT2-series Smart Slave.
2. From the Main Window, open the Network Configuration Window and double-click or click the right mouse button over the icon of the DRT2-series Smart Slave to be set. Select **Parameter** and **Edit** to display the Edit Device Parameters Window.  
From the Maintenance Mode Window, click the right mouse button over the icon of the DRT2-series Smart Slave to be set. Select **Parameter** and **Edit** to display the Edit Device Parameters Window.



3. Select the **Operation Time** Tab.

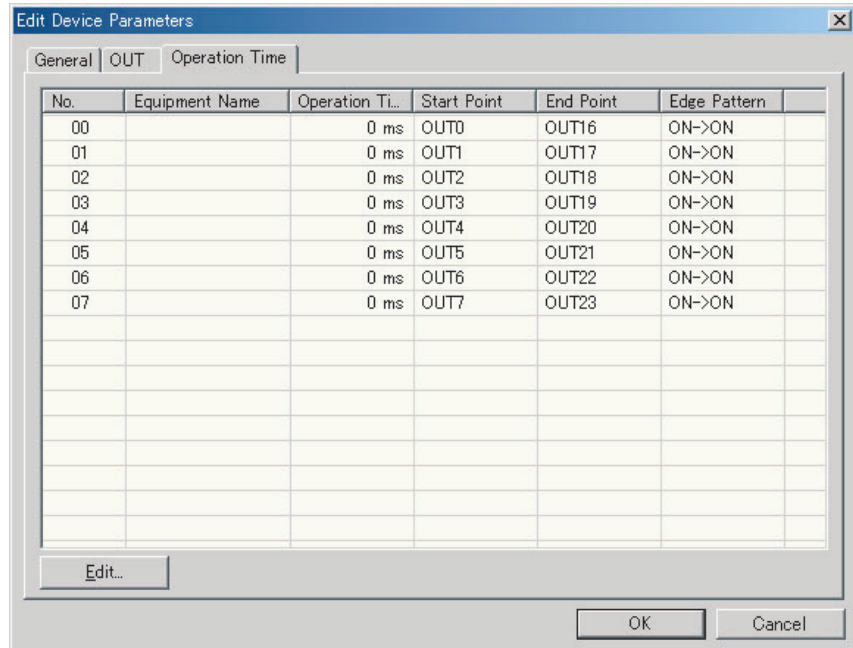

4. Double-click the *Equipment Name* field of the applicable device to display the following window.  
Enter the set value in the *Operation Time* field and select the monitor contact numbers for the starting point and ending point from the pull-down menu. The edge pattern can be set for monitoring at either the ON edge or the OFF edge. Finally click the **OK** Button.

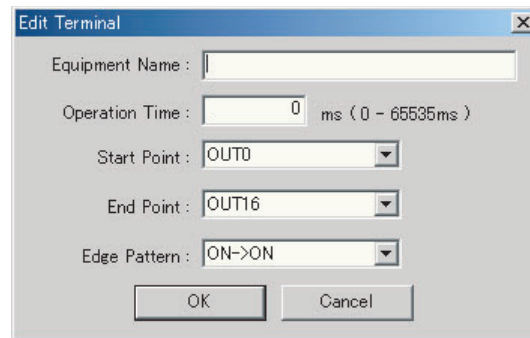

5. Check that the value set in the *Operation Time* field is reflected in the Edit Device Parameters Window. Select the **General** Tab, click the **Download** Button, and then click the **Reset** Button to reset the Unit.
6. Click the **OK** Button.

### 4-3-7 Sensor Disconnected Detection

DRT2-ID□□C-1, DRT2-ID□□SLH-1, and DRT2-MD32SLH-1

#### Function Overview

The I/O power supply current can be monitored and, for Screw-less Clamp Terminals, a sensor disconnection will be detected if the current drops to 0.3 mA or lower per input connector (0.5 mA or lower, at 2 contacts per connector for an Environment-resistive 16-point Input Terminal). The connector that has a disconnected contact can be checked according to the LED indicators on the Slave Unit. (Refer to the information below.)

When a disconnection is detected, the Sensor Disconnected Flag in the Status Area will turn ON. The Configurator or explicit messages can be used to read the status of the Sensor Disconnected Flag, and to read the status of the disconnected contact.

The Configurator or explicit messages can be used to enable or disable the sensor disconnected detection for each contact. (Sensor disconnected detection is disabled in the factory setting.)

Disconnection of the signal line for three-wire sensors cannot be detected by this function. (A disconnected power line can be detected, however.) Disconnection may be falsely detected for sensors (dry contacts such as limit switches or relays, and some other two-wire proximity sensors) with a current consumption of 0.3 mA or lower (0.5 mA or lower for Environment-resistive Terminals), so always disable this function when using these sensors.

Environment-resistive Terminal, Screw-less Clamp Terminal

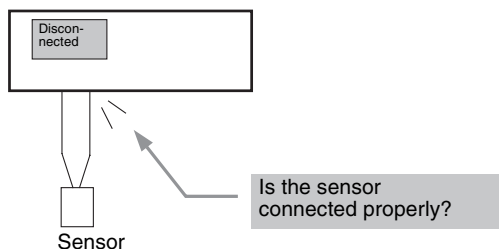

**I/O Indicator Status when Disconnection is Detected**

**Environment-resistive Terminals**

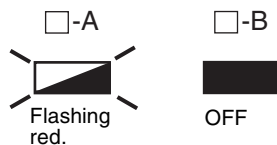

The box indicates the number of the corresponding connector.

- Note**
1. Refer to *SECTION 6 Environment-resistive Slaves* for the position of the actual indicator.
  2. For 16-point Input Units, the settings cannot be set to both enable and disable within the same connector.
  3. After a sensor disconnection is detected, a delay of up to 1.2 s will occur before the Sensor Disconnected Flag turns ON.

**Screw-less Clamp Terminals**



**Setting Using the DeviceNet Configurator**

The method used to set values from the DeviceNet Configurator (Ver. 2.20 or later) is described here.

- 1,2,3...**
1. Turn ON the power to the DRT2-series Smart Slave.
  2. From the Main Window, open the Network Configuration Window and double-click or click the right mouse button over the icon of the DRT2-series Smart Slave to be set. Select **Parameter** and **Edit** to display the Edit Device Parameters Window.

From the Maintenance Mode Window, click the right mouse button over the icon of the DRT2-series Smart Slave to be set. Select **Parameter** and **Edit** to display the Edit Device Parameters Window.

3. Select the **IN** Tab.

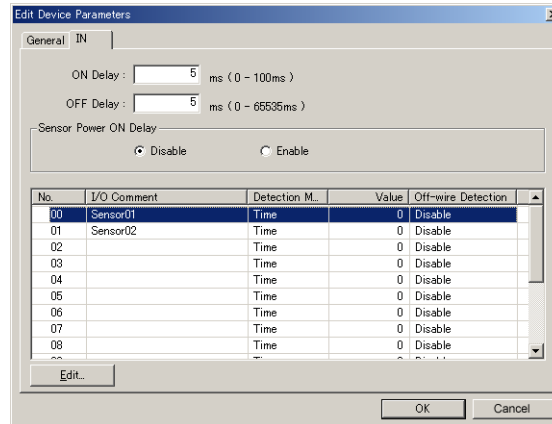

4. Double-click the name of the applicable terminal to display the following window. Enable off-wire (disconnection) detection and click the **OK** Button.

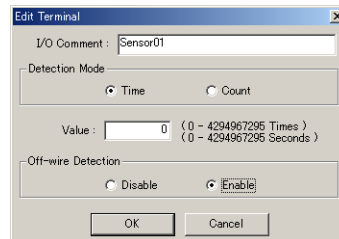

5. Select the **General** Tab, click the **Download** Button, and then click the **Reset** Button to reset the Unit.
6. Click the **OK** Button.

### 4-3-8 Detection of Sensor Power Short-circuit

DRT2-ID□□C(-1), DRT2-ID16S(-1), DRT2-MD16S(-1), DRT2-ID□□SLH(-1), and DRT2-MD32SLH(-1)

#### Function Overview

The sensor power supply current can be monitored, and when the current reaches or exceeds 100 mA per input contact (two contacts per connector for a 16-point Environment-resistive Input Terminal), a sensor power short-circuit is detected.

If a sensor power short-circuit is detected when using Environment-resistive Terminals or Screw-less Clamp Terminals, the sensor power output is forced OFF for the contact. (Input contacts that have not short-circuited will continue to operate normally.) The indicators on the Slave can be used to check which contacts have been detected with power short-circuits. (Refer to the information below.)

If a short-circuit is detected in any of the contacts when a Sensor Connector Terminal is being used, the I/O power is turned OFF for the Unit. Check whether a sensor power short-circuit has been detected using the indicators on the slave.

When a sensor power short-circuit is detected, the Sensor Power Short-circuited Flag in the Status Area will turn ON. The Sensor Power Short-circuited Flag can be read using the Configurator or explicit messages. The sensor will automatically recover when the cause of the short-circuit is removed, and the

power output to the connector where the short-circuit was detected will turn ON.

Environment-resistive Terminal, Sensor Connector Terminal, or Screw-less Clamp Terminal

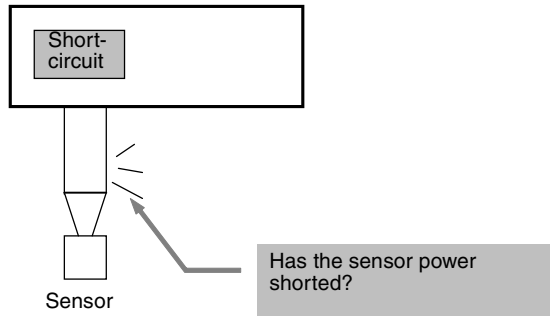

**Note** Use a Power Supply Unit with a rated power supply of 50 W for the communications power supply. A short-circuit is detected when the Unit's sensor power output current reaches or exceeds 100 mA per input connector. When a short-circuit occurs, the communications power supply may be temporarily interrupted. After a short-circuit has been detected, the power will be automatically restored, but during the power interruption use an external circuit in the configuration to make sure the system is operating safely.

Use the following equations to calculate the sensor's current consumption.

$$\text{Total network current} = \text{Total Unit current consumption} + \text{Total sensor current consumption}$$

$$\text{Communications power supply capacity} \geq (\text{Total network current} + \text{Short-circuit detection current}) \times (=100 \text{ mA}) \times (\text{DeviceNet network voltage})$$

**I/O Indicator Status when Short-circuit is Detected (Environment-resistive Terminal Input Units)**



The box indicates the number of the corresponding connector.

- Note**
1. Refer to *SECTION 6 Environment-resistive Slaves* for the position of the actual indicator.
  2. After a sensor short-circuit is detected, a delay of up to 1.2 s will occur before the Sensor Power Shorted Flag is turned ON.

**SHT0 Indicator Status when Short-circuit Is Detected (Sensor Connector Terminal Input Units and I/O Units)**

This indicator lights red when a short-circuit error is detected.

**I/O Indicator Status when Short-circuit is Detected (Screw-less Clamp Terminal Input Units, Mixed Units)**

This indicator lights red when a short-circuit error is detected.

0 to 15



Lit red.

**Checking Using the DeviceNet Configurator**

The method used to check information from the DeviceNet Configurator (Ver. 2.20 or later) is described here.

- 1,2,3... 1. Turn ON the power to the DRT2-series Smart Slave.
2. Click the right mouse button over the icon of the DRT2-series Smart Slave to be set in the Network Configuration Window, and select **Monitor**.
3. Select the **IN** Tab from the Monitor Device Window. When a short-circuit is detected, the short-circuit status will be displayed in the *Short-circuit* field.

**Monitor Device Window for Environment-resistive Terminals**

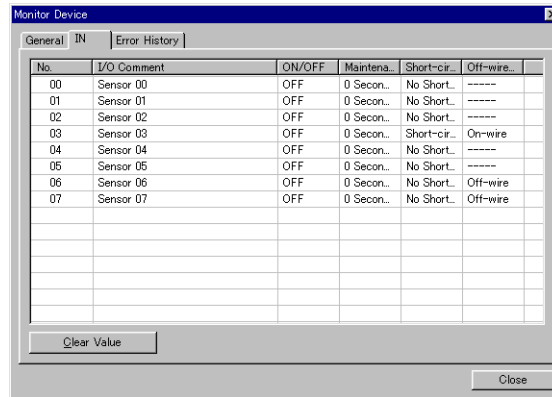

**Monitor Device Window for Sensor Connector Terminals**

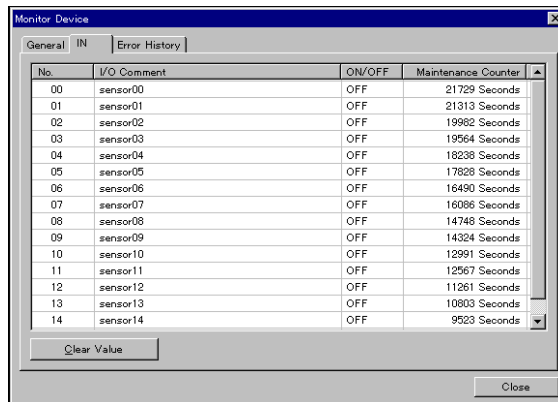

**4-3-9 External Load Short-circuit Detection**

DRT2-OD□□C(-1), DRT2-MD16S(-1), and DRT2-OD16SLH(-1)

**Function Overview**

The load current of the Output Unit can be monitored, and an external load short-circuit can be detected when the current drops below a set value per contact (or common). When an external load short-circuit is detected, the output is turned OFF to prevent damage to the Unit's output circuit. With Environment-resistive Terminals, output contacts that have not short-circuited will operate normally. The LED indicators on the Slave Unit can be used to check which contact has been detected as having an external load short-circuit. (Refer to the information below.) Either the Configurator or explicit messages can be used to read which contact has the external load short-circuit. When an external load short-circuit is detected, the Short-circuited Flag in the Status Area is turned ON. (The Configurator or explicit messages can be used to read the status of the Short-circuited Flag.) The Unit will recover when the cause of the short-circuit is removed by automatic or manual recovery. Set the

recovery method using the Configurator or explicit messages. (The factory setting is for manual recovery.)

Environment-resistive Terminal, Sensor Connector Terminal, or Screw-less Clamp Terminal

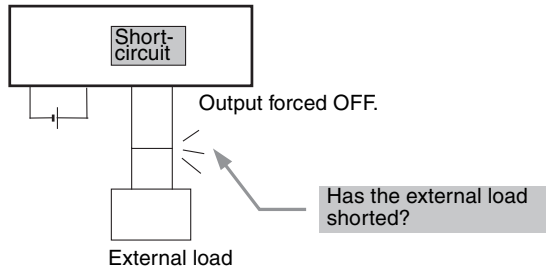

- Note**
1. Refer to *Load Short-circuit Protection: DRT2-OD16SLH and DRT2-OD16SLH-1* on page 218 and *Load Short-circuit Protection: DRT2-OD08C and DRT2-OD08C-1* on page 258 for more information.
  2. Environment-resistive Terminals  
 The OMRON S8□□ Power Supply Unit is recommended for the I/O power supply. The load short-circuit detection function uses the transistor's thermal shutdown, so when a Power Supply Unit with a low-capacity rating or instantaneous shutoff overcurrent protection is used, the load short-circuit may not be detected. Always use a Power Supply Unit with a rating of 100 W or higher if it uses a dropping overcurrent protection characteristic. Always use a Power Supply Unit with a rating of 150 W or higher if it uses intermittent overcurrent protection. The current limiter will protect the transistor even if short-circuit detection is disabled.

**Sensor Connector Terminals**

The OMRON S8□□ Power Supply Unit is recommended for the I/O power supply. If a Power Supply Unit with a dropping overcurrent protection characteristic is used, the load short-circuit may not be detected. Always use a Power Supply Unit with a rating of 100 W or higher if it uses a dropping overcurrent protection characteristic. Always use a Power Supply Unit with a rating of 150 W or higher if it uses intermittent overcurrent protection. The current limiter will protect the transistor even if short-circuit detection is disabled.

**I/O Indicator Status when Short-circuit is Detected (Environment-resistive Terminal Input Units)**

■ **Automatic Recovery Mode**

When the cause of the short-circuit has been removed, the short-circuit protection status will automatically be cleared by rewiring the corresponding contact correctly. After short-circuit detection, the short-circuit protection status will also be cleared automatically by turning OFF the output. The output must remain ON for checking the Status Area and indicators.

**I/O Indicator Status when Short-circuit Detected**

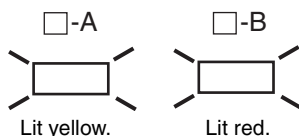

The box indicates the number of the corresponding connector.

- Note** Refer to *SECTION 6 Environment-resistive Slaves* for the position of the actual indicator.

■ **Manual Recovery Mode**

When the cause of the short-circuit is removed and the corresponding contact is correctly rewired, the short-circuit protection status is cleared by turning ON the I/O power or the communications power. When the I/O power is OFF or the output is OFF, the short-circuit protection status is maintained, so the shorted locations can be easily identified from the indicator status during on-site maintenance.

**I/O Indicator Status when Short-circuit Detected**

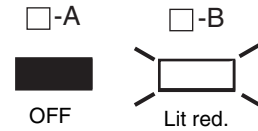

The box indicates the number of the corresponding connector.

**Note** Refer to *SECTION 6 Environment-resistive Slaves* for the position of the actual indicator.

**SHT1 Indicator Status When Short-circuit Is Detected for a Sensor Connector Terminal I/O Unit**

This indicator lights red when a short-circuit error is detected.

**I/O Indicator Status When Short-circuit Is Detected for a Screw-less Clamp Terminal I/O Unit**

■ **Automatic Recovery Mode**

When the wiring has been corrected to remove the short-circuit, the short-circuit protection status will automatically be cleared. The short-circuit protection status will also be cleared automatically when the output is turned OFF. The output must remain ON to check the Status Area and indicators.

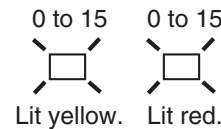

■ **Manual Recovery Mode**

After the wiring has been corrected to remove the short-circuit, the short-circuit protection status is cleared by cycling the I/O power or the communications power. When the I/O power or the output is OFF, the short-circuit protection status will be maintained, so short-circuited locations can be easily identified from the indicator status during onsite maintenance.

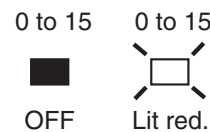

**Checking Using the DeviceNet Configurator**

The method used to check information from the DeviceNet Configurator (Ver. 2.20 or later) is described here.

**Checking Shorted Devices**

The procedure for this checking method is the same from both the Main Window and the Maintenance Mode Window.

1,2,3...

1. Turn ON the power to the DRT2-series Smart Slave.
2. Click the right mouse button over the icon of the DRT2-series Smart Slave to be set in the Network Configuration Window, and select **Monitor**.

3. Select the **General** Tab from the Monitor Device Window. If *External Load Short-circuit Detection* is selected, a short-circuit has been detected.

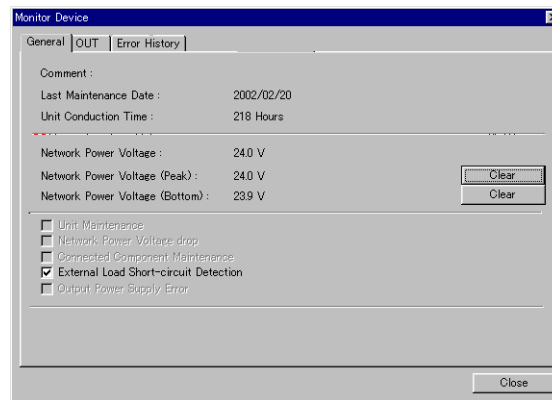

4. When a short-circuit detection has been confirmed, determine which device has shorted from the OUT Tab Page.

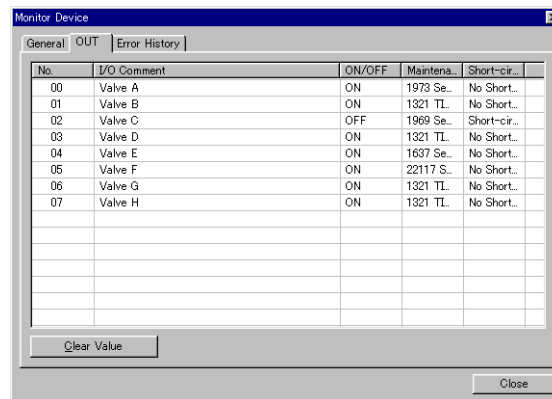

**Setting to Automatic/Manual Recovery Mode (Environment-resistive Terminals Only)**

- 1,2,3... 1. Turn ON the power to the DRT2-series Smart Slave.
2. From the Main Window, open the Network Configuration Window and double-click or click the right mouse button over the icon of the DRT2-series Smart Slave to be set. Select **Parameter** and **Edit** to display the Edit Device Parameters Window.  
From the Maintenance Mode Window, click the right mouse button over the icon of the DRT2-series Smart Slave to be set. Select **Parameter** and **Edit** to display the Edit Device Parameters Window.
3. Select the **OUT** Tab.  
Select either **Manual** or **Automatic** for the external output load short-cir-



cuit recovery mode and click the **OK** Button.

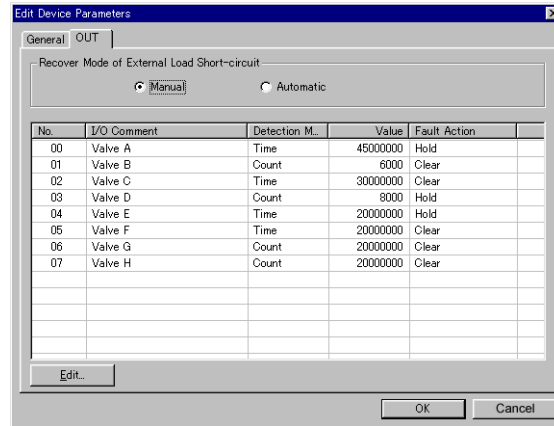

4. Select the **General** Tab, click the **Download** Button, and then click the **Reset** Button to reset the Unit.
5. Click the **OK** Button.

### 4-3-10 External Load Disconnected Detection

DRT2-OD□□SLH(-1) and DRT2-MD32SLH(-1)

#### Function Overview

This function monitors the current consumption for the external load and detects an external load disconnection if the current drops below a set value. (See note.) The indicators on the Slave can be used to check which contacts have been detected. (See below.)

When a disconnection is detected, the External Load Disconnected Flag in the Status Area will turn ON. The External Load Disconnected Flag can be read by using the Configurator or explicit messages. Information on the contacts that are disconnected can also be read.

The Configurator or explicit messages can be used to enable or disable this function for each set of contacts. (External load disconnected detection is disabled in the factory setting.)

There are two recovery methods that can be used when an external load disconnection is detected: automatic or manual. The Configurator or an explicit message can be used to set the recovery method to automatic or manual. (The factory setting is for manual recovery.)

**Note** If an external load with low current consumption is connected, a disconnection may not be detected. Disable this function when the output current is 3 mA or less.

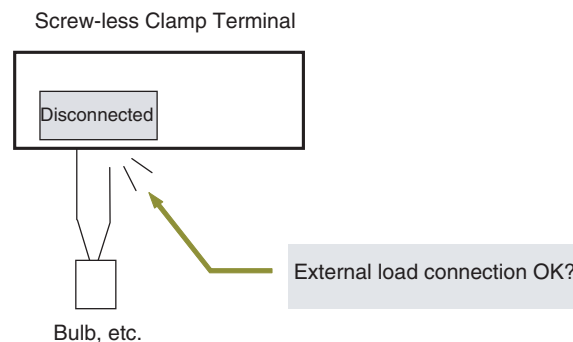

**Automatic Recovery Mode** Recovery is automatic when the wiring is corrected.

**Manual Recovery Mode**

Recovery occurs when the wiring is corrected and the I/O power supply is turned back ON.

**I/O Indicator Status when Disconnection is Detected**

0 to 15



Flashing red.

**Setting Using the DeviceNet Configurator**

The method used to set values from the DeviceNet Configurator (Ver. 2.20 or later) is described here.

1,2,3...

1. Turn ON the power to the DRT2-series Smart Slave.
2. From the Main Window, open the Network Configuration Window and double-click or click the right mouse button over the icon of the DRT2-series Smart Slave to be set. Select **Parameter** and **Edit** to display the Edit Device Parameters Window.  
From the Maintenance Mode Window, click the right mouse button over the icon of the DRT2-series Smart Slave to be set. Select **Parameter** and **Edit** to display the Edit Device Parameters Window.
3. Select the **IN** Tab.

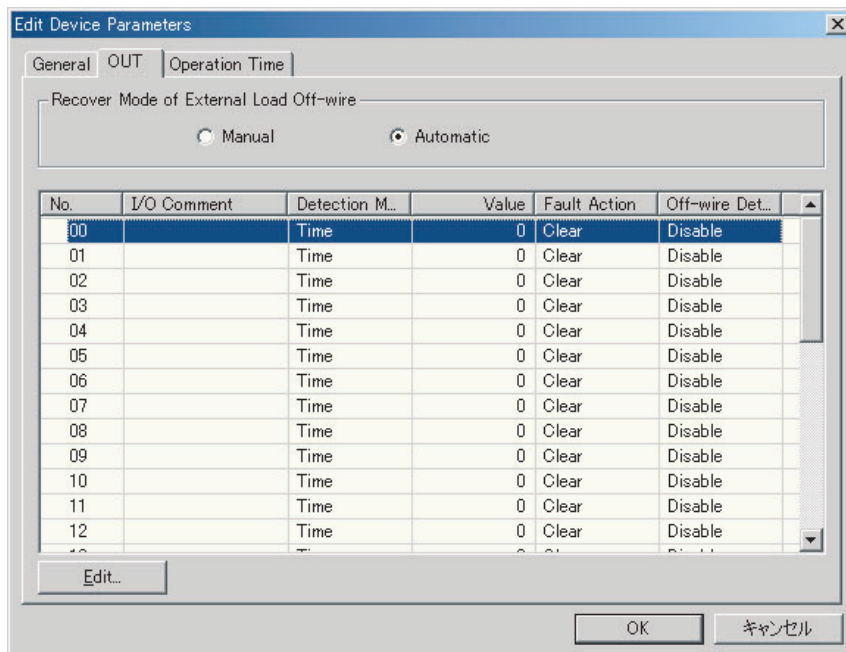

4. Double-click the name of the applicable terminal to display the following window. Enable disconnection detection and click the **OK** Button.

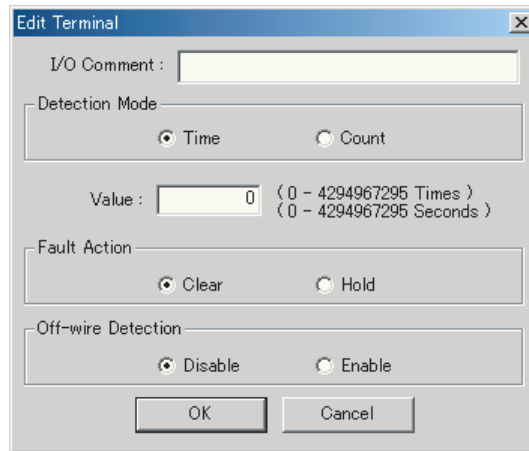

5. Select the **General** Tab, click the **Download** Button, and then click the **Reset** Button to reset the Unit.
6. Click the **OK** Button.

# SECTION 5

## General-purpose Slaves

This section provides the specifications and describes the components, terminal arrangements, basic procedures for wiring, and methods for connecting cables of General-purpose Slaves. Information on Slave settings, mounting and wiring methods are also provided separately for each Slave type.

5-1	Common Specifications for General-purpose Slaves . . . . .	85
5-1-1	Current Consumption and Weights . . . . .	85
5-2	Connecting Communications Cables to General-purpose Slaves . . . . .	87
5-2-1	Connecting Communications Cables . . . . .	87
5-2-2	Connecting Communications Cables to the Nodes . . . . .	89
5-3	Mounting Terminating Resistors . . . . .	91
5-4	Maintenance Information Window . . . . .	91
5-4-1	Checking Maintenance Information . . . . .	92
5-5	Remote I/O Terminals with Transistors . . . . .	97
5-5-1	Node Address, Baud Rate, and Output Hold/Clear Settings . . . . .	97
5-5-2	Increasing I/O Using an Expansion Unit . . . . .	100
5-5-3	Remote I/O Terminals with 8 Transistor Inputs: DRT2-ID08 (NPN) and DRT2-ID08-1 (PNP) . . . . .	102
5-5-4	Remote I/O Terminals with 8 Transistor Outputs: DRT2-OD08 (NPN) and DRT2-OD08-1 (PNP) . . . . .	104
5-5-5	Remote I/O Terminals with 16 Transistor Inputs: DRT2-ID16 (NPN) and DRT2-ID16-1 (PNP) . . . . .	107
5-5-6	Remote I/O Terminals 16 Transistor Outputs: DRT2-OD16 (NPN) and DRT2-OD16-1 (PNP) . . . . .	110
5-5-7	Remote I/O Terminals with 8 Transistor Inputs and 8 Transistor Outputs: DRT2-MD16 (NPN) and DRT2-MD16-1 (PNP) . . . . .	113
5-5-8	Remote I/O Terminal with 16 Relay Outputs: DRT2-ROS16 . . . . .	116
5-5-9	Remote I/O Terminal Expansion Units with 8 Transistor Inputs: XWT-ID08 (NPN) and XWT-ID08-1 (PNP) . . . . .	120
5-5-10	Remote I/O Terminal Expansion Units 16 Transistor Inputs: XWT-ID16 (NPN) and XWT-ID16-1 (PNP) . . . . .	123
5-5-11	Remote I/O Terminal Expansion Units with 8 Transistor Outputs: XWT-OD08 (NPN) and XWT-OD08-1 (PNP) . . . . .	126
5-5-12	Remote I/O Terminal Expansion Units with 16 Transistor Outputs: XWT-OD16 (NPN) and XWT-OD16-1 (PNP) . . . . .	129
5-5-13	Transistor Remote Input Terminals with 16 Points and 3-tier I/O Terminal Blocks: DRT2-ID16TA (NPN) and DRT2-ID16TA-1 (PNP) . . . . .	132
5-5-14	Transistor Remote Output Terminals with 16 Points and 3-tier I/O Terminal Blocks: DRT2-OD16TA (NPN) and DRT2-OD16TA-1 (PNP) . . . . .	135
5-5-15	Transistor Remote I/O Terminals with 8 Inputs and 8 Outputs and 3-tier I/O Terminal Blocks: DRT2-MD16TA (NPN) and DRT2-MD16TA-1 (PNP) . . . . .	139
5-5-16	Mounting in Control Panels . . . . .	142
5-5-17	Wiring the I/O Power Supply and I/O Lines . . . . .	143

5-6	Connector Terminals with Transistors . . . . .	144
5-6-1	Node Address, Baud Rate, and Output Hold/Clear Settings . . . . .	144
5-6-2	Industry Standard Sensor Connector Assembly, Wiring, and Installation	145
5-6-3	Connector Terminals with 16 Transistor Inputs: DRT2-ID16S (NPN) and DRT2-ID16S-1 (PNP) . . . . .	148
5-6-4	Connector Terminals (Sensor Connector Type with 8 Inputs and 8 Outputs): DRT2-MD16S (NPN) and DRT2-MD16S-1 (PNP) . . .	150
5-6-5	Transistor Remote Input Terminals with 16 Points and Connectors: DRT2-ID16ML(X) (NPN) and DRT2-ID16ML(X)-1 (PNP) . . . . .	153
5-6-6	Connector Terminals (MIL Connector Type with 16 Outputs): DRT2-OD16ML(X) (NPN) and DRT2-OD16ML(X)-1 (PNP) . . . . .	157
5-6-7	Transistor Remote Input Terminals with 32 Points and Connectors: DRT2-ID32ML (NPN) and DRT2-ID32ML-1 (PNP) . . . . .	160
5-6-8	Transistor Remote Output Terminals with 32 Points and Connectors: DRT2-OD32ML (NPN) and DRT2-OD32ML-1 (PNP) . . . . .	166
5-6-9	Transistor Remote I/O Terminals with 16 Inputs and 16 Outputs and Connectors: DRT2-MD32ML (NPN) and DRT2-MD32ML-1 (PNP) . . . . .	170
5-6-10	Board-type Connector Terminals with 32 Inputs and MIL Connectors: DRT2-ID32B (NPN)/DRT2-ID32B-1 (PNP) and DRT2-ID32BV (NPN)/DRT2-ID32BV-1 (PNP) . . . . .	184
5-6-11	Board-type Connector Terminals with 32 Outputs and MIL Connectors: DRT2-OD32B (NPN)/DRT2-OD32B-1 (PNP) and DRT2-OD32BV (NPN)/DRT2-OD32BV-1 (PNP) . . . . .	188
5-6-12	Board-type Connector Terminals with 16 Inputs, 16 Outputs and MIL Connectors: DRT2-MD32B (NPN)/DRT2-MD32B-1 (PNP) and DRT2-MD32BV (NPN)/DRT2-MD32BV-1 (PNP) . . . . .	192
5-7	Screw-less Clamp Terminals . . . . .	203
5-7-1	Node Address, Baud Rate, and Output Hold/Clear Settings . . . . .	203
5-7-2	Wiring to a Screw-less Clamp Terminal Block . . . . .	203
5-7-3	I/O Indicators . . . . .	205
5-7-4	Screw-less Clamp Terminals with 16 Transistor Inputs . . . . .	205
5-7-5	Screw-less Clamp Terminals with 32 Transistor Inputs . . . . .	209
5-7-6	Screw-less Clamp Terminals with and 16 Transistor Outputs . . . . .	214
5-7-7	Screw-less Clamp Terminals with and 32 Transistor Outputs . . . . .	220
5-7-8	Screw-less Clamp Terminals with 16 Transistor Inputs and Outputs	225
5-7-9	Mounting to a Control Panel . . . . .	231

## 5-1 Common Specifications for General-purpose Slaves

The following table lists specifications which are common to all General-purpose Slaves. For details of specifications for each Slave, refer to the following Slave specifications pages.

Item	Specifications
Communications power supply voltage	11 to 25 V DC (Supplied from the communications connector.)
I/O power supply voltage	20.4 to 26.4 V DC (24 V DC, -15 to +10%)
Noise immunity	Conforms to IEC61000-4-4. 2 kV (power lines)
Vibration resistance	10 to 60 Hz, 0.7-mm double amplitude 60 to 150 Hz, 50 m/s <sup>2</sup> For 80 min. in each direction
Shock resistance	150 m/s <sup>2</sup> , 3 times in each direction
Dielectric strength	500 V AC (between isolated circuits)
Insulation resistance	20 MΩ min. at 250 V DC (between isolated circuits)
Ambient temperature	-10 to +55°C
Ambient humidity	25% to 85% (with no condensation)
Operating environment	No corrosive gases
Storage temperature	-25 to +65°C
Mounting	35-mm DIN Track mounting or M4 screw mounting
Mounting strength	50 N Track direction: 10 N
Screw tightening torque	M2 (communications connector lock screws): 0.26 to 0.3 N·m M3 wiring screws: 0.5 N·m M3 mounting screws: 0.5 N·m M4 (Unit mounting screws): 0.6 to 0.98 N·m

**Note** Some items for the DRT2-ROS16 (Remote I/O Terminal with relay outputs) have different specifications. Refer to 5-5-8 *Remote I/O Terminal with 16 Relay Outputs: DRT2-ROS16*.

### 5-1-1 Current Consumption and Weights

The following table lists the current consumption and weights for general-purpose Slaves.

Model	Communications current consumption	Weight
DRT2-ID08	55 mA max.	135 g max.
DRT2-ID08-1	55 mA max.	135 g max.
DRT2-OD08	50 mA max.	135 g max.
DRT2-OD08-1	45 mA max.	135 g max.
DRT2-MD16	55 mA max.	145 g max.
DRT2-MD16-1	50 mA max.	145 g max.
DRT2-ID16	60 mA max.	140 g max.
DRT2-ID16-1	60 mA max.	140 g max.
DRT2-OD16	60 mA max.	140 g max.
DRT2-OD16-1	60 mA max.	140 g max.
DRT2-ROS16	395 mA max.	260 g max.
XWT-ID08 (See note.)	5 mA max.	80 g max.
XWT-ID08-1 (See note.)	5 mA max.	80 g max.

Model	Communications current consumption	Weight
XWT-ID16 (See note.)	10 mA max.	120 g max.
XWT-ID16-1 (See note.)	10 mA max.	120 g max.
XWT-OD08 (See note.)	4.5 mA max.	80 g max.
XWT-OD08-1 (See note.)	4.5 mA max.	80 g max.
XWT-OD16 (See note.)	10 mA max.	120 g max.
XWT-OD16-1 (See note.)	10 mA max.	120 g max.
DRT2-ID16TA	80 mA max.	300 g max.
DRT2-ID16TA-1	80 mA max.	300 g max.
DRT2-OD16TA	80 mA max.	300 g max.
DRT2-OD16TA-1	80 mA max.	300 g max.
DRT2-MD16TA	80 mA max.	300 g max.
DRT2-MD16TA-1	80 mA max.	300 g max.
DRT2-ID16S	230 mA max.	90 g max.
DRT2-ID16S-1	230 mA max.	90 g max.
DRT2-MD16S	135 mA max.	95 g max.
DRT2-MD16S-1	135 mA max.	95 g max.
DRT2-ID16ML	60 mA max.	85 g max.
DRT2-ID16ML-1	60 mA max.	85 g max.
DRT2-ID16MLX	60 mA max.	95 g max.
DRT2-ID16MLX-1	60 mA max.	95 g max.
DRT2-OD16ML	75 mA max.	105 g max.
DRT2-OD16ML-1	75 mA max.	105 g max.
DRT2-OD16MLX	75 mA max.	115 g max.
DRT2-OD16MLX-1	75 mA max.	115 g max.
DRT2-ID16SL	28 mA max.	240 g max.
DRT2-ID16SL-1	28 mA max.	240 g max.
DRT2-OD16SL	32 mA max.	240 g max.
DRT2-OD16SL-1	32 mA max.	240 g max.
DRT2-ID16SLH	32 mA max.	250 g max.
DRT2-ID16SLH-1	32 mA max.	250 g max.
DRT2-OD16SLH	35 mA max.	250 g max.
DRT2-OD16SLH-1	35 mA max.	250 g max.
DRT2-ID32ML	100 mA max.	120 g max.
DRT2-ID32ML-1	100 mA max.	120 g max.
DRT2-OD32ML	120 mA max.	100 g max.
DRT2-OD32ML-1	120 mA max.	100 g max.
DRT2-MD32ML	110 mA max.	120 g max.
DRT2-MD32ML-1	110 mA max.	120 g max.
DRT2-ID32B	100 mA max.	50 g max.
DRT2-ID32BV	100 mA max.	50 g max.
DRT2-ID32B-1	100 mA max.	50 g max.
DRT2-ID32BV-1	100 mA max.	50 g max.
DRT2-OD32B	120 mA max.	50 g max.
DRT2-OD32BV	120 mA max.	50 g max.
DRT2-OD32B-1	120 mA max.	50 g max.
DRT2-OD32BV-1	120 mA max.	50 g max.
DRT2-MD32B	110 mA	50 g max.
DRT2-MD32BV	110 mA	50 g max.

Model	Communications current consumption	Weight
DRT2-MD32B-1	110 mA	50 g max.
DRT2-MD32BV-1	110 mA	50 g max.
DRT2-ID32SL	100 mA max.	480 g max.
DRT2-ID32SL-1	90 mA max.	480 g max.
DRT2-OD32SL	80 mA max.	480 g max.
DRT2-OD32SL-1	75 mA max.	480 g max.
DRT2-MD32SL	80 mA max.	480 g max.
DRT2-MD32SL-1	80 mA max.	480 g max.
DRT2-ID32SLH	100 mA max.	480 g max.
DRT2-ID32SLH-1	105 mA max.	480 g max.
DRT2-OD32SLH	80 mA max.	480 g max.
DRT2-OD32SLH-1	85 mA max.	480 g max.
DRT2-MD32SLH	90 mA max.	480 g max.
DRT2-MD32SLH-1	90 mA max.	480 g max.

**Note** The communications current consumption indicated for Expansion Units are the additional current consumed when the Expansion Unit is connected to a Basic Unit. For example, the current consumption for a DRT2-ID16 Basic Unit used with an XWT-OD16 Expansion Unit is 60 + 10 = 70 mA.

## 5-2 Connecting Communications Cables to General-purpose Slaves

Communications cables are connected to General-purpose Slaves using normal square connectors.

### 5-2-1 Connecting Communications Cables

Use the following procedure to prepare the communications cables and connect them to the connectors.

The same methods are used to connect the cables to connectors with and without set screws.

- 1,2,3...**
1. Remove about 30 to 80 mm of the cable covering, being careful not to damage the mesh shield underneath. Do not remove more than necessary. Removing excessive cable covering may cause a short-circuit.

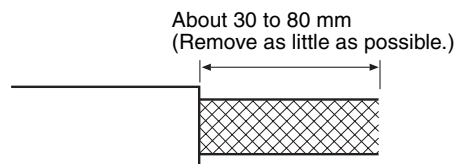

2. Peel back the mesh shield carefully to expose the signal lines, power lines, and the shielding wire. The shielding wire will be loose on the outside of



the other lines, but it is harder than the mesh shield and should be easily identified.

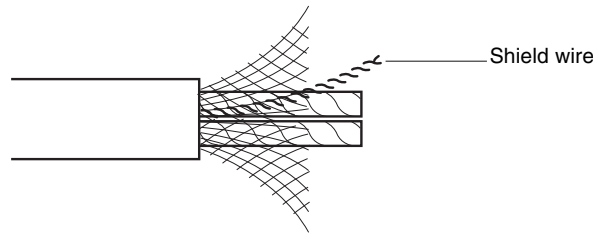

- Remove the exposed mesh shield, remove the aluminum tape from the signal and power lines, and strip the covering from the signal and power lines to the proper length for the crimp terminal connectors. Twist together the wires of each of the signal and power lines.

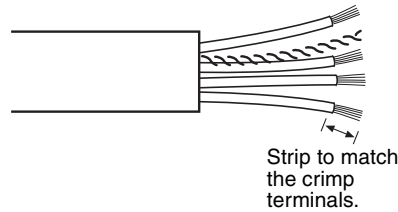

- Attach the crimp terminals to the lines and then cover any exposed areas of the cable and lines with electrician's tape or heat-shrinking tubes.
- Orient the connector properly, loosen the line set screws, and then insert the lines in order: Red, white, shield, blue, and then black.
- Connectors without set screws do not require lines to be secured with screws as with previous connectors. Push up the orange tab and then insert each line into the back of each hole. Release the orange lever after inserting the lines, and gently pull each line to check that it is securely connected to the connector.

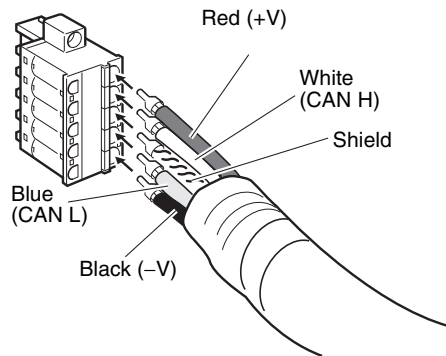

There are colored stickers provided on the Master Unit and Slaves that match the colors of the lines to be inserted. Check that the colors of the lines and stickers match when wiring the connectors.

Note The colors used are as follows:

Color	Signal
Red	Power line, positive voltage (+V)
White	Communications line, high (CAN H)
---	Shield

Color	Signal
Blue	Communications line, low (CAN L)
Black	Power line, negative voltage (-V)

**Note** Secure the DeviceNet cable near the Unit to prevent any force from being applied to the Unit's connector.

**Precautions**

**Recommended Crimp Terminals**

PHOENIX CONTACT, A-/AI-series Crimp Terminals

Cable type		Connector type			Applicable tool
		XW4B-05C1-H1-D XW4B-05C1-V1R-D MSTB2.5/5-ST-5.08AU	XW4B-05C4-TF-D XS4B-05C4-T-D	XW4G-05C1-H1-D XW4G-05C4-TF-D	
Thin Cable	Signal line	AI 0.25-6BU	AI 0.25-8YE	AI 0.25-8YE	CRIMPFOX ZA3
	Power line	AI 0.5-6WH	AI 0.5-10WH	AI 0.5-10WH	
Thick Cable	Signal line	A1-6	A1-10	A1-10	
	Power line	AI 2.5-8BU	AI 2.5-10BU	AI 2.5-10BU	

**OMRON XW4Z-00C Screwdriver for Fastening Line Set Screws**

The end of the screwdriver has the following dimensions.

Side View      Front View

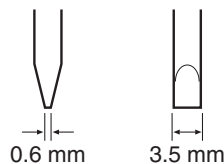

**Supplying Communications Power Using T-branch Taps**

Connect the +V and -V of the power lines to the connectors in the same way as for communications cables. If the communications power supply is in one location only, connect a shield to the connectors when securing them, and ground to 100 Ω max.

T-branch Tap or Power Supply Tap

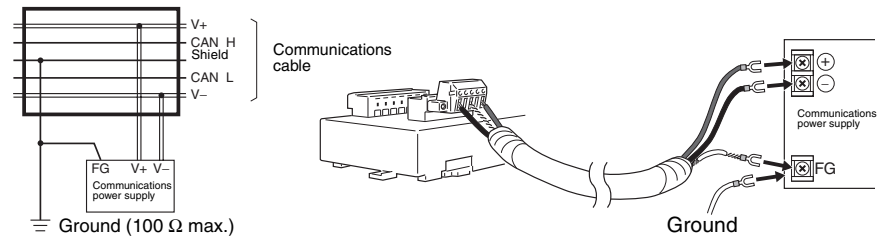

Power supply with cable grounded (one location only)

**5-2-2 Connecting Communications Cables to the Nodes**

Align the node connector with the cable connector and fully insert the projecting part of the cable connector into the node connector.

Depending on the type of Slave used, the connectors are secured with screws or there is no component for securing the connectors. Always secure the con-

nectors that can be secured with set screws to a tightening torque of 0.25 to 0.3 N-m.

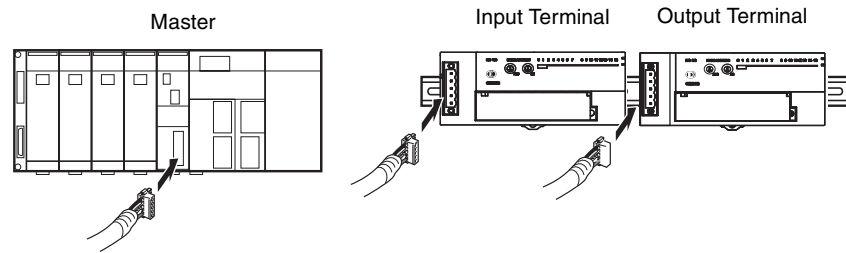

**Precautions**

**Multi-drop Connections (Thin Cables)**

The connectors provided with the Units can be used for multi-drop connections by inserting two lines of the same color into a single hole, as shown in the following diagram.

**Example:**

Multi-drop Connection for a Connector without Set Screws

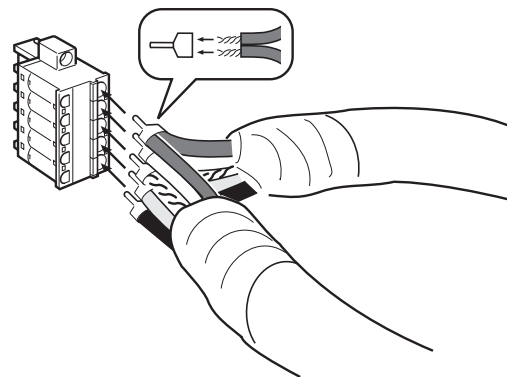

When inserting two lines into the same hole, first insert them together into a pressure-welded terminal, as shown below.

Pressure-welded terminal for 2 lines



We recommend using the following crimp terminals and crimp tools.

Connector	Pressure-welded terminal	Tool
XW4B-05C1-H1-D MSTB2.5/5-ST-5.08 XW4B-05C1-V1R-D	AI-TWIN2 × 0.5-8WH PHOENIX CONTACT	CRIMPFOX UD6 or CRIMPFOX ZA3
XW4G-05C1-H1-D	H0.5/16.5 ZH Weidmueller	

**Multi-drop Connections with Special Connector (Thin or Thick Cables)**

A multi-drop wiring connector (sold separately) can be used to wire a multi-drop connector for either Thin or Thick Cables. This multi-drop wiring connector is required when using Thick Cables, which are too thick for two lines to fit into the connector provided with the Units.

Purchase the multi-drop wiring connector when using Thick Cables for multi-drop connections.

The multi-drop wiring connector cannot be used with Master Units if it will come in contact with Units mounted next to the Master Unit. Use a T-branch Tap to wire the connection instead.

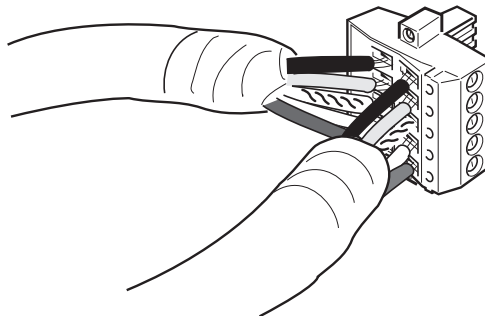

### 5-3 Mounting Terminating Resistors

Terminating Resistors must be used at both ends of the trunk line.

A Terminating Resistor is either connected to a T-branch Tap or a Terminal-block Terminating Resistor is connected to a communications cable extended from a node.

#### T-branch Tap Terminating Resistors

Terminating Resistors are included with the T-branch Tap.

Insert the Terminating Resistor into the T-branch Tap, as shown in the following diagram. The Terminating Resistor can face either direction.

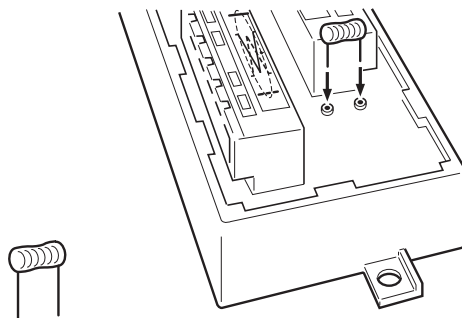

#### Terminal-block Terminating Resistors

The DRS1-T Terminal Block has a built-in Terminating Resistor. Attach crimp terminals to the communications cable in the same way as connecting a standard terminal block, and securely screw the terminals to the Terminal-block Terminating Resistor.

Use M3 crimp terminals for the signal wires.

Tighten the screws to a torque of 0.3 to 0.5 N·m.

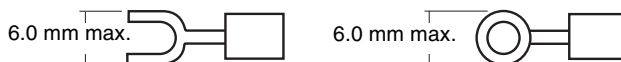

### 5-4 Maintenance Information Window

This section describes the Maintenance Information Window, which can be used to check the status of various general-purpose Slaves. The Monitor Device Window can be used to check the same Slave status information, but the examples in this section uses the Maintenance Information Window. Refer to 4-1-2 Maintenance Mode Window for details on the differences between the Maintenance Information Window and the Monitor Device Window.

### 5-4-1 Checking Maintenance Information

From the DeviceNet Configurator's Main Window, click the right mouse button and select **Maintenance Information**. (From the Maintenance Mode Window, double-click the icon of the desired Slave.

#### General Window

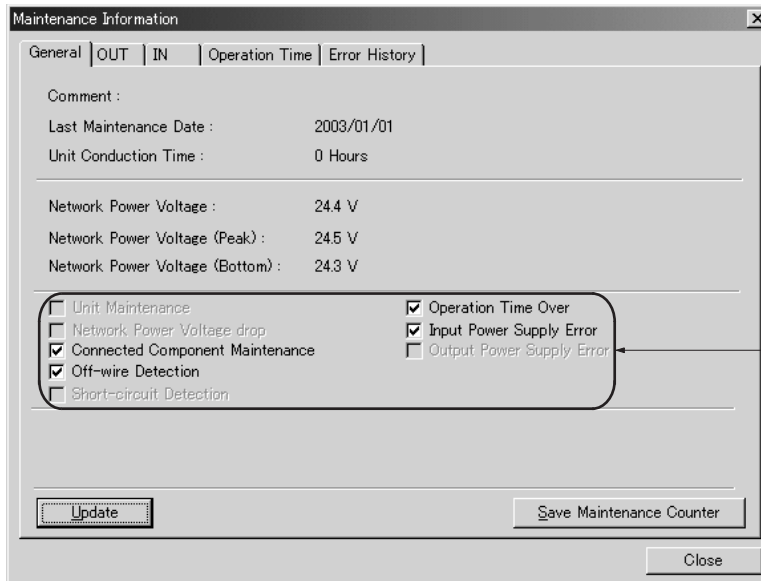

Status check boxes (Status flags)

Item	Description
Comment	Displays up to 32 characters of text set as the Unit comment.
Last Maintenance Date	Displays the last maintenance date that was set.
Unit Conduction Time	Displays the total time that the Unit has been ON (cumulative power ON time).
Network Power Voltage	Displays the present network power supply voltage.
Network Power Voltage (Peak)	Displays the maximum power supply voltage up to the present time.
Network Power Voltage (Bottom)	Displays the minimum power supply voltage up to the present time.
Update Button	Click this Button to update the Maintenance information.
Save Maintenance Counter	This function saves the Maintenance counter value in the Unit. If this function is used, the previous value will be retained when the power supply is turned OFF and ON again.

**Note** Always update the information when the parameters have been edited or set.

#### Status Check Boxes

The flags (check boxes) shown in the following table will be turned ON when the corresponding error occurs.

Item	Description
Unit Maintenance	ON when the total Unit ON time exceeds the set value.
Network Power Voltage Drop	ON when the network power supply voltage falls below the set value.
Connected Device Maintenance	ON when any I/O point's Total ON Time Monitor or Contact Operation Counter exceeds its user-set monitor value.

Item	Description
External Load/Sensor Disconnected Detection	<p>ON when the External Load Disconnected Detection or Sensor Disconnection Detection function is triggered.</p> <p>Models supporting External Load Disconnected Detection (for outputs): DRT2-OD□□SLH(-1) and DRT2-MD32SLH(-1) Screw-less Clamp Terminals</p> <p>Models supporting Sensor Disconnected Detection (for inputs): DRT2-ID□□SLH(-1) and DRT2-MD32SLH(-1) Screw-less Clamp Terminals</p>
Sensor Power Short-circuit Detection and External Load Short-circuit Detection	<p>ON when the External Load Short-circuit Detection or Sensor Power Short-circuit Detection function is triggered.</p> <p>Models supporting this function (for inputs): DRT2-ID□□SLH(-1) and DRT2-MD32SLH(-1) Screw-less Clamp Terminals and DRT2-ID16S(-1) and DRT2-MD16S(-1) Sensor Connector Terminals</p> <p>(When using a Sensor Connector Terminal, the I/O power supply to the entire Terminal will be turned OFF if a short circuit is detected in even one sensor's power supply.)</p>
Operation Time Over	<p>ON when the measured operation time exceeds the user-set monitor value.</p> <p>Basic models*: DRT2-MD16(-1), DRT2-ID16(-1), and DRT2-OD16(-1)</p> <p>Relay output model*: DRT2-ROS16</p> <p>Sensor Connector models: DRT2-MD16S(-1)</p> <p>3-tier I/O Terminal Block models: DRT2-□D16TA(-1)</p> <p>MIL Connector models: DRT2-□D16ML(X)(-1), DRT2-□D32ML(-1), DRT2-□D32B(-1), and DRT2-□D32BV(-1)</p> <p>Screw-less Clamp models: DRT2-□D□□SL(-1) and DRT2-□D□□SLH(-1)</p> <p>*This function can be used in these models only when an Expansion Unit is mounted and the Slave operates as an I/O Unit.</p>

Item	Description
I/O Power Supply Error (Input)	ON when the input power supply is OFF. Basic models*: DRT2-ID08(-1), DRT2-MD16(-1), and DRT2-ID16(-1) Relay output model*: DRT2-ROS16 Sensor Connector models: DRT2-MD16S(-1) 3-tier I/O Terminal Block models: DRT2-ID16TA(-1) and DRT2-MD16TA(-1) MIL Connector models: DRT2-ID16ML(X)(-1), DRT2-ID32ML(-1) and DRT2-MD32ML(-1), DRT2-ID32B(-1), DRT2-MD32B(-1), DRT2-ID32BV(-1), and DRT2-MD32BV(-1) Screw-less Clamp models: DRT2-ID□□SL(-1), DRT2-ID□□SLH(-1), DRT2-MD32SL(-1), and DRT2-MD32SLH(-1) *This function can be used for outputs in these models only when an Expansion Unit is mounted and the Slave operates as an I/O Unit.
I/O Power Supply Error (Output)	ON when the output power supply is OFF. Basic models*: DTR2-OD08(-1), DRT2-MD16(-1), and DRT2-OD16(-1) Relay output model*: DRT2-ROS16 Sensor Connector models: DRT2-MD16S(-1) 3-tier I/O Terminal Block models: DRT2-ID16TA(-1) and DRT2-MD16TA(-1) MIL Connector models: DTR2-OD16ML(X)(-1), DRT2-OD32ML(-1), DRT2-MD32ML(-1), DRT2-OD32B(-1), DRT2-MDD32B(-1) DRT2-OD32BV(-1), and DRT2-MD32BV(-1) Screw-less Clamp models: DRT2-OD□□SL(-1), DRT2-OD□□SLH(-1), DRT2-MD32SL(-1), and DRT2-MD32SLH(-1) *This function can be used for outputs in these models only when an Expansion Unit is mounted and the Slave operates as an I/O Unit.

**Tabs in the Maintenance Information Window**

**OUT Window**

Terminals are listed in numerical order.

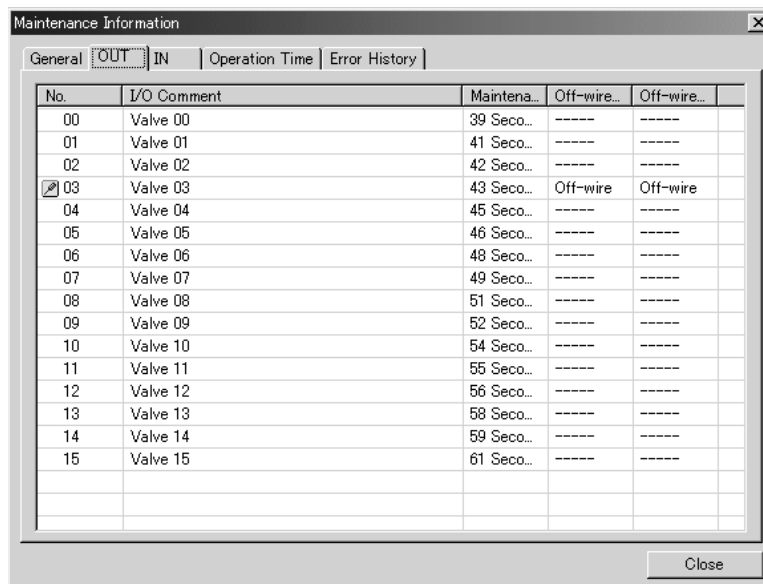

Item	Description
Comment	Displays up to 32 characters of text set as the output comment for each output.
Maintenance Counter	Displays the maintenance counter for each output. If the maintenance counter exceeds the threshold value, a warning icon will be displayed on the left side of the output's No. column. Total ON Time Monitor: Units = seconds Contact Operation Counter: Units = operations
Load Disconnection Detection	If load disconnection detection (off-wire detection) is enabled, either <i>Not off-wire</i> or <i>Off-wire</i> will be displayed. If off-wire detection is disabled, --- will be displayed.
Load Short-circuit Detection	If load short-circuit detection is enabled, either <i>No short-circuit</i> or <i>Short-circuit</i> will be displayed. If short-circuit detection is disabled, --- will be displayed.
Load Disconnection Detection History	Records information when a disconnection occurred. When load disconnections are not being detected, --- will be displayed.
Load Short-circuit Detection History	Records information when a short-circuit occurs. When load short-circuits are not being detected, --- will be displayed.

- Note**
1. The Load Disconnection Detection and Load Disconnection Detection History functions are supported by the following models:  
DRT2-OD□□SLH(-1) and DRT2-MD32SLH(-1) Screw-less Clamp Terminals
  2. The Load Short-circuit Detection and Load Short-circuit Detection History functions are supported by the following models:  
DRT2-MD16S(-1) Sensor Connector Terminals and DRT2-OD16SLH(-1) Screw-less Clamp Terminals.

**IN Window**

Terminals are listed in numerical order.

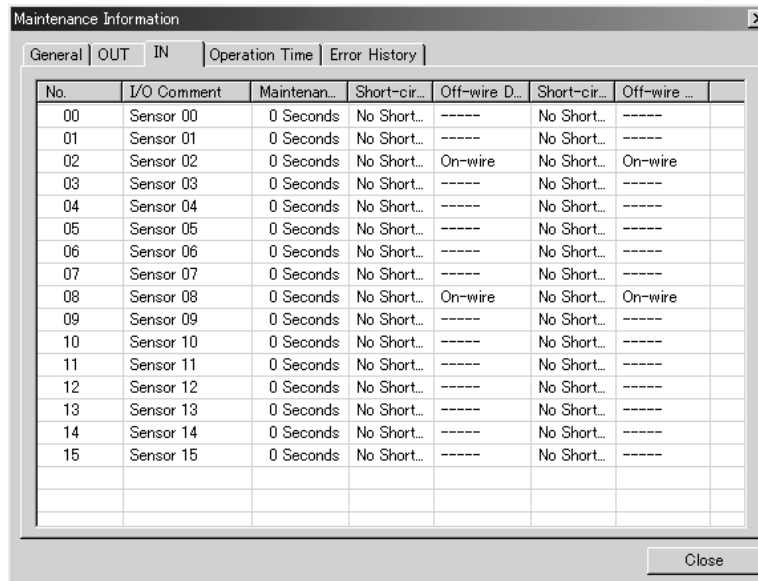

Item	Description
Comment	Displays up to 32 characters of text set as the input comment for each input.
Maintenance Counter	Displays the maintenance counter for each input. If the maintenance counter exceeds the threshold value, a warning icon will be displayed on the left side of the input's No. column. Total ON Time Monitor: Units = seconds Contact Operation Counter: Units = operations



Item	Description
Power Supply Short-circuit	When sensor power short-circuit detection is ON for each input, <i>Shorted</i> will be displayed.
Disconnection Detection	If sensor disconnection detection (off-wire detection) is enabled for each input, either <i>Connected</i> or <i>Disconnected</i> will be displayed. If disconnection detection is disabled, --- will be displayed.
Power Supply Short-circuit History	Records information when a short-circuit occurred.
Disconnection Detection History	Records information when a disconnection occurred even once.

- Note**
- The Sensor Disconnection Detection function is supported by the following models:  
DRT2-ID□□SLH(-1) and DRT2-MD32SLH(-1) Screw-less Clamp Terminals
  - The Sensor Power Supply Short-circuit function is supported by the following models:  
DRT2-ID□□SLH(-1) and DRT2-MD32SLH(-1) Screw-less Clamp Terminals and DRT2-ID16S(-1) and DRT2-MD16S(-1) Sensor Connector Terminals

**Operation Time Window**

Terminals are listed in numerical order.

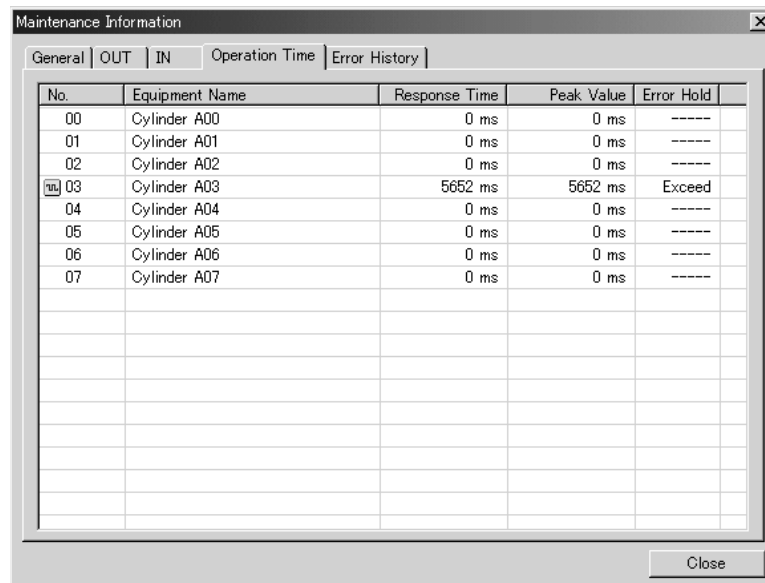

Item	Description
Monitored Device Name	Displays up to 16 characters of text set as the comment for each monitored device.
Operation Time	Displays the operation time (in ms) for each device. If the operation time exceeds the threshold, a warning icon will be displayed on the left side of the terminal's No. column.
Peak Operation Time	Displays the maximum operation time that has occurred.
Error History	If the operation time exceeded the threshold value even once, <i>Over-threshold</i> will be displayed.

- Note**
- The Operation Time Monitor function is supported by the following models:  
Basic models: DRT2-MD16(-1), DRT2-ID16(-1), and DRT2-OD16(-1)  
Relay output model: DRT2-ROS16  
(Supported only when an Expansion Unit is mounted and the Slave oper-

ates as an I/O Unit.)

Sensor Connector models: DRT2-MD16S(-1)

3-tier I/O Terminal Block models: DRT2-□D16TA(-1)

MIL Connector models: DRT2-□D16ML(X)(-1), DRT2-□D32ML(-1), DRT2-□D32B(-1), and DRT2-□D32BV(-1)

Screw-less Clamp models: DRT2-□D□□SL(-1) and DRT2-□D□□SLH(-1)

- The Peak Operation Time and Error History functions are supported by the following models:

3-tier I/O Terminal Block models: DRT2-□D16TA(-1)

MIL Connector models: DRT2-□D16ML(X)(-1), DRT2-□D32ML(-1), DRT2-□D32B(-1), and DRT2-□D32BV(-1)

Screw-less Clamp models: DRT2-□D□□SL(-1) and DRT2-□D□□SLH(-1)

### Error History Window

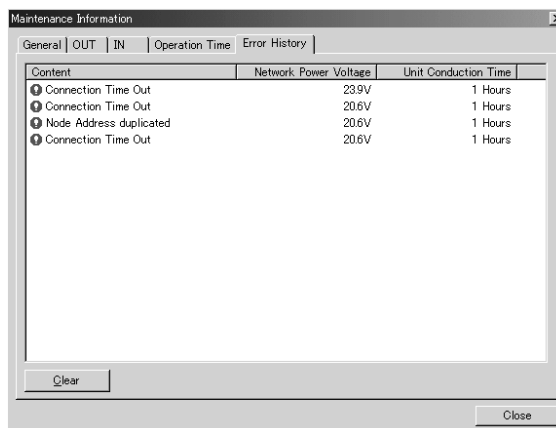

Item	Description
Content	Displays the contents of the communications errors that occurred.
Network Power Voltage	Displays the power supply voltage being supplied when the error occurred.
Unit Conduction Time	Displays the total time that the network power supply had been ON when the error occurred. DRT2-TS04□ only)
Clear Button	Clears the error history.

**Note** The Unit Conduction Time display is supported by the following models:  
 3-tier I/O Terminal Block models: DRT2-□D16TA(-1)  
 MIL Connector models: DRT2-□D16ML(X)(-1), DRT2-□D32ML(-1), DRT2-□D32B(-1), and DRT2-□D32BV(-1)  
 Screw-less Clamp models: DRT2-□D□□SL(-1) and DRT2-□D□□SLH(-1)

## 5-5 Remote I/O Terminals with Transistors

### 5-5-1 Node Address, Baud Rate, and Output Hold/Clear Settings

This section describes the Slaves' node address setting, baud rate settings, and hold/clear outputs for communications error settings. These settings are made as follows:

Node address setting: Rotary switch

Baud rate setting: Automatic follow-up

Output hold/clear setting: Software switch

**Node Address Settings**

The node address of the Remote I/O Terminal is set as a decimal, using the left rotary switch for the ten's digit, and the right rotary switch for the one's digit. (Up to 63 nodes can be set.)

Node addresses 64 to 99 can be set from the Configurator, using the following method.

- Note**
1. The rotary switch settings are read when the power is turned ON.
  2. The rotary switches of the DRT2-□D□□ML(X)(-1) are located on the top of the Terminal.

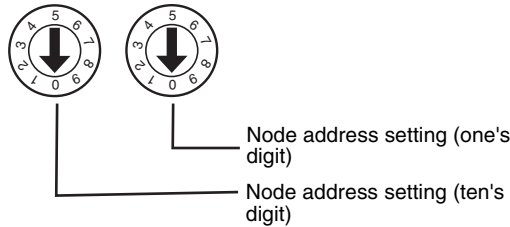

**Setting Node Addresses Using the DeviceNet Configurator**

- 1,2,3... 1. Select **Setup Node Address/Baud rate** from the **Tools** Menu.

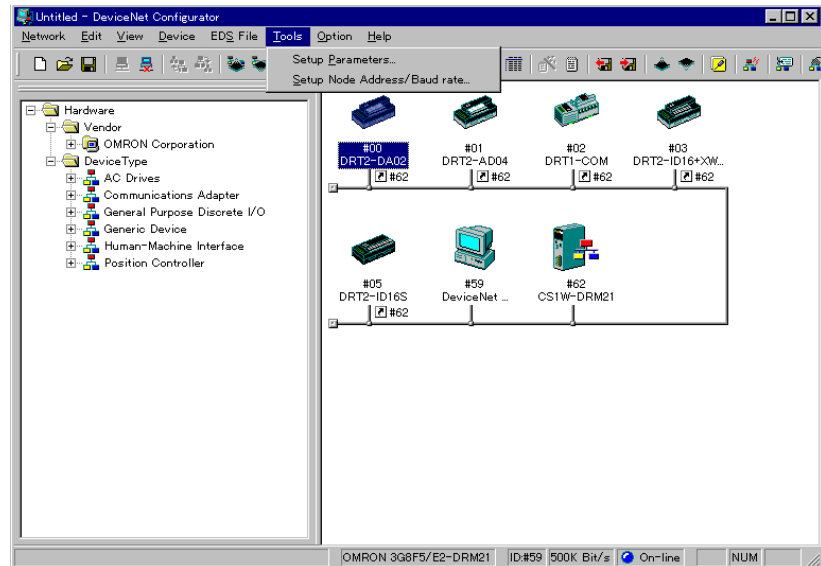

2. The following window will be displayed. Input the node address of the Unit to be changed and the new node address, and then click the **Change** Button.

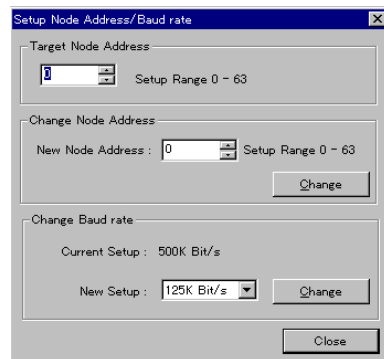

**Note** Any node address within the setting range can be used as long as it is not already set for another node. Setting the same node address for more than one node will cause a node address duplication error and communications will not start.

## **Baud Rate Setting**

The baud rate of the whole system is determined by the baud rate set for the Master Unit. Setting the baud rate for each Unit is not required.

## **Output Hold/Clear Setting**

Use the Configurator to set the output hold/clear settings. The factory setting is for outputs to be cleared.

OFF (Clear): When a communications error occurs, all of the output data from the Master is cleared to 0.

ON (Hold): When a communications error occurs, the output data from the Master is held at its previous status.

The Output Hold/Clear setting method is shown below.

### **Setting Output Hold/Clear from the Configurator**

- 1,2,3...**
- From the Main Window, open the Network Configuration Window and double-click or click the right mouse button over the icon of the corresponding DRT2-series Smart Slave. Select **Parameter** and **Edit** to display the Edit Device Parameters Window.  
From the Maintenance Mode Window, open the Network Configuration Window in the Configurator and click the right mouse button over the icon of the corresponding DRT2-series Smart Slave. Select **Parameter** and **Edit** to display the Edit Device Parameters Window.
  - Select the **OUT** Tab.

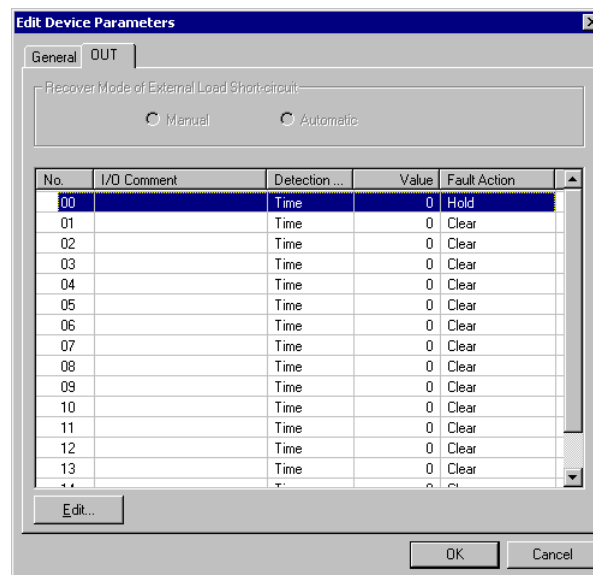

- Double-click the name of the applicable terminal to display the following window.

Select either *Clear* or *Hold* for the output during a communications error. Click the **OK** Button.

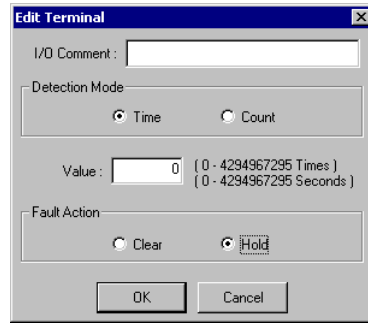

4. After checking that the setting that the output during a communications error is reflected in the Edit Device Parameters Window, select the **General** Tab and click the **Download** Button.

### 5-5-2 Increasing I/O Using an Expansion Unit

A single Basic Unit can be combined with a single Expansion Unit.

#### Expansion Unit Combinations

Basic Unit	Expansion Unit	Inputs	Outputs
DRT2-ID16	None	16	0
	XWT-ID08-(1)	24	0
	XWT-OD08-(1)	16	8
	XWT-ID16-(1)	32	0
	XWT-OD16-(1)	16	16
DRT2-OD16	None	0	16
	XWT-ID08-(1)	8	16
	XWT-OD08-(1)	0	24
	XWT-ID16-(1)	16	16
	XWT-OD16-(1)	0	32
DRT2-ROS16	None	0	16
	XWT-ID08-(1)	8	16
	XWT-OD08-(1)	0	24
	XWT-ID16-(1)	16	16
	XWT-OD16-(1)	0	32

#### Mounting Expansion Units

- 1,2,3... 1. Remove the cover from the right side of the Basic Unit.

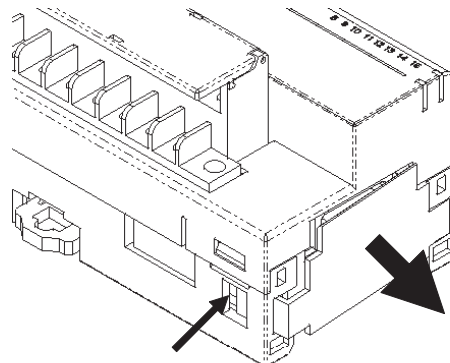

- Join the connector of the Expansion Unit directly to the connector of the Basic Unit.

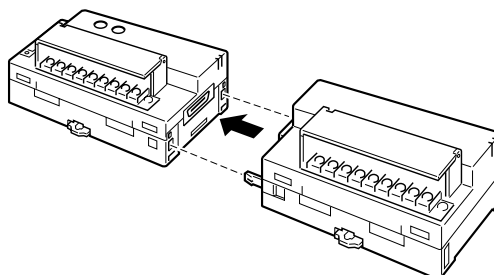

- Insert the connector of the Expansion Unit securely into the connector of the Basic Unit.

### Supplying I/O Power

When supplying I/O power to an Expansion Unit in a combination of two Input Units (Basic Input Unit and Expansion Input Unit), I/O power is supplied to the Basic Unit only.

For combinations of a Basic Input Unit with an Expansion Output Unit, a Basic Output Unit with an Expansion Input Unit, or two Output Units (Basic Output Unit and Expansion Output Unit), the I/O power must be supplied to both the Basic Unit and the Expansion Unit.

Refer to the following table to determine the correct wiring for the Unit combination being used.

Device combination	I/O power supply to Expansion Unit
Basic Input Unit (IN) + Expansion Input Unit (IN): Example: DRT2-ID16+XWT-ID16	Not required. (I/O power supply shared with Basic Unit.) (See note 1.)
Basic Input Unit (IN) + Expansion Output Unit (OUT): Example: DRT2-ID16+XWT-OD16	Required. (I/O power supply required for both Units.)
Basic Output Unit (OUT) + Expansion Input Unit (IN): Example: DRT2-OD16+XWT-ID16	Required. (I/O power supply required for both Units.)
Basic Output Unit (OUT) + Expansion Output Unit (OUT): Example: DRT2-OD16+XWT-OD16	Required. (I/O power supply required for both Units.)
Basic Output Unit (OUT) + Expansion Input Unit (IN): Example: DRT2-ROS16+XWT-ID16	Required. (I/O power supply required for Expansion Unit only.)
Basic Output Unit (OUT) + Expansion Output Unit (OUT): Example: DRT2-ROS16+XWT-OD16	Required. (I/O power supply required for Expansion Unit only.)

- Note**
- When an NPN or PNP Basic Input Unit and NPN Expansion Input Unit are combined, the V terminals of the Basic Input Unit and Expansion Input Unit are connected internally. (Example: DRT2-ID16(-1)+XWT-ID16)  
When an NPN or PNP Basic Input Unit and PNP Expansion Input Unit are combined, the G terminals of the Basic Input Unit and Expansion Input Unit are connected internally. (Example: DRT2-ID16(-1)+XWT-ID16-1)
  - Always turn OFF the power to the Units before connecting an Expansion Unit.

### 5-5-3 Remote I/O Terminals with 8 Transistor Inputs: DRT2-ID08 (NPN) and DRT2-ID08-1 (PNP)

#### Input Specifications

Item	Specifications	
Model	DRT2-ID08	DRT2-ID08-1
Internal I/O common	NPN	PNP
Input points	8 points	
ON voltage	15 V DC min. (between each input terminal and V)	15 V DC min. (between each input terminal and G)
OFF voltage	5 V DC max. (between each input terminal and V)	5 V DC max. (between each input terminal and G)
OFF current	1 mA max.	
Input current	6.0 mA max./point (for 24 V DC) 3.0 mA max./point (for 17 V DC)	
ON delay time	1.5 ms max.	
OFF delay time	1.5 ms max.	
Number of circuits	8 points with one common	

#### Component Names and Functions: DRT2-ID08 and DRT2-ID08-1

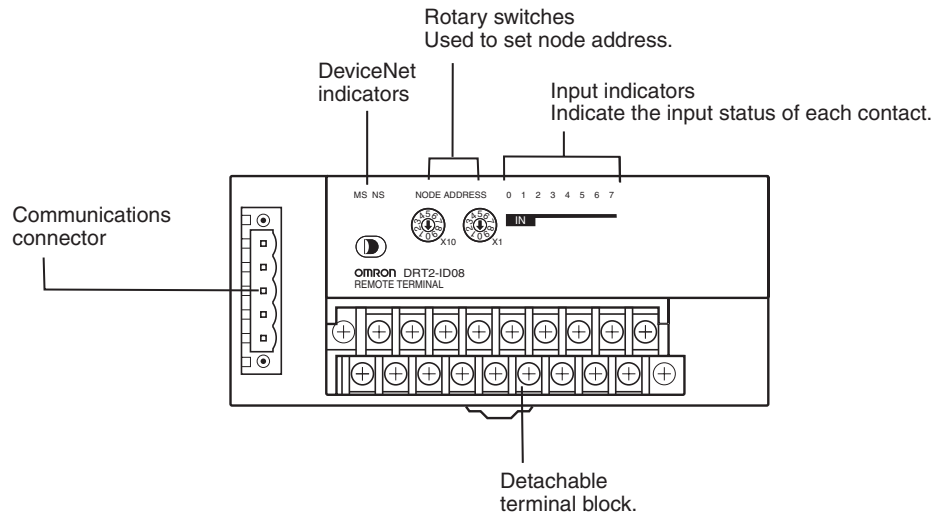

**Internal Circuits**

**DRT2-ID08 (NPN)**

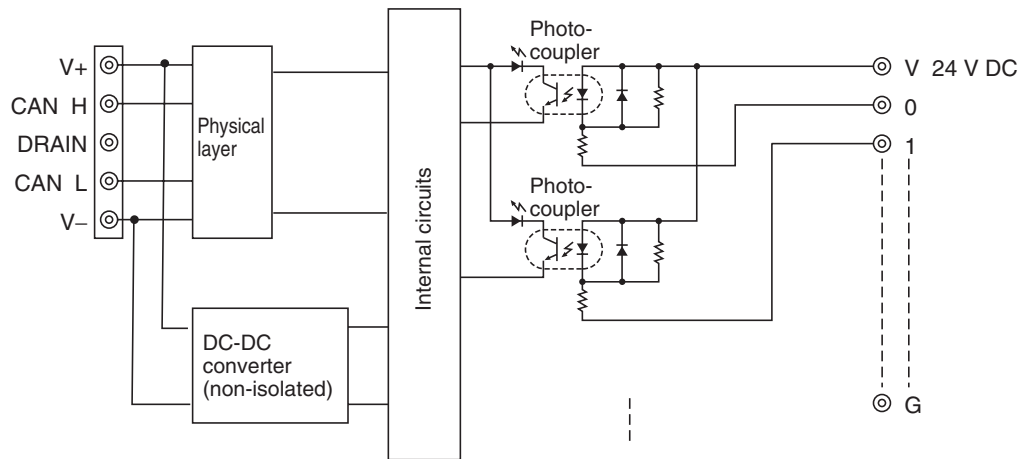

**DRT2-ID08-1 (PNP)**

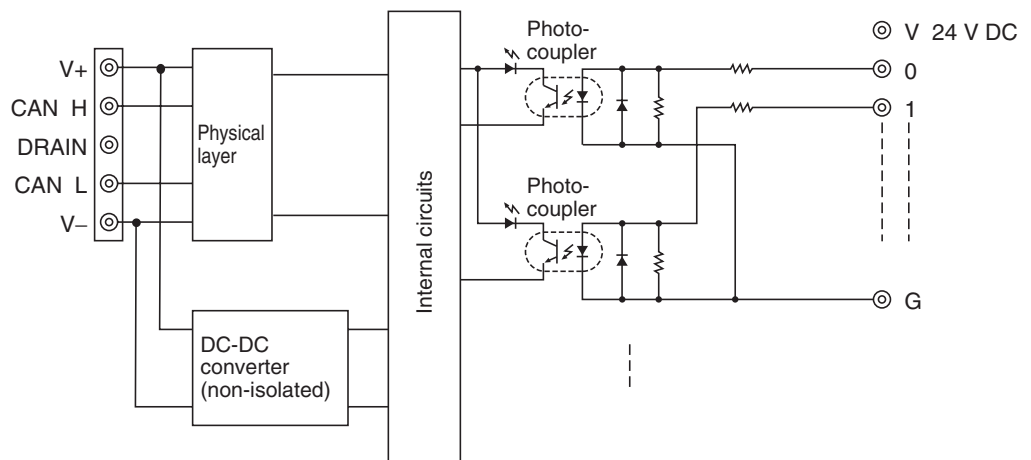

**Wiring**

**DRT2-ID08 (NPN)**

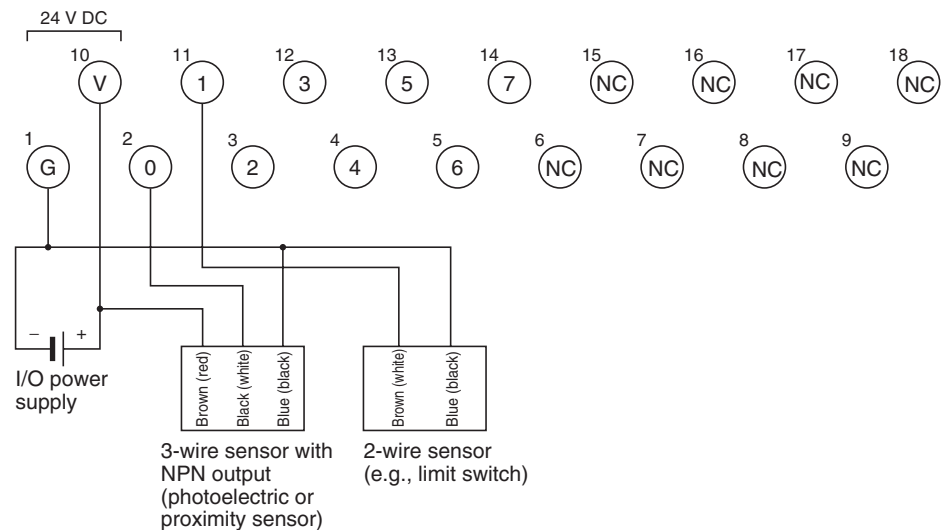



DRT2-ID08-1 (PNP)

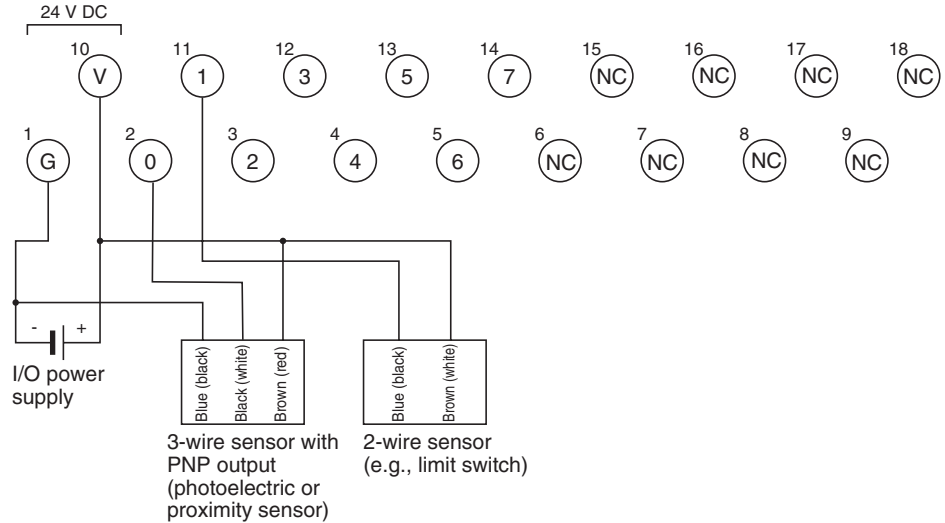

**Note** Wire colors in parentheses are the previous JIS colors for photoelectric and proximity sensors.

**Dimensions: DRT2-ID08 and DRT2-ID08-1**

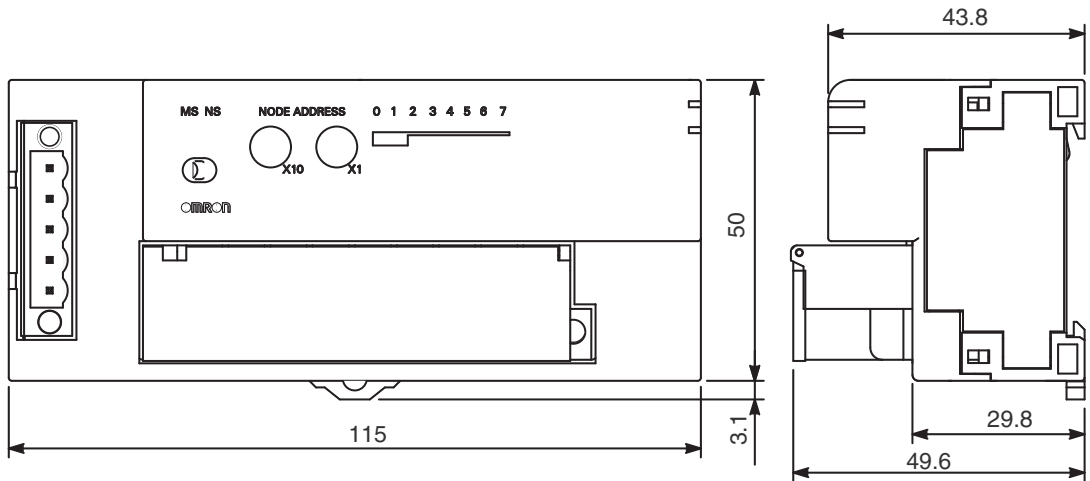

**5-5-4 Remote I/O Terminals with 8 Transistor Outputs: DRT2-OD08 (NPN) and DRT2-OD08-1 (PNP)**

**Output Specifications**

Item	Specifications	
Model	DRT2-OD08	DRT2-OD08-1
Internal I/O common	NPN	PNP
Output points	8 points	
Rated output current	0.5 A/point, 4.0 A/common	
Residual voltage	1.2 V max. (at 0.5 A between each output terminal and G)	1.2 V max. (at 0.5 A between each output terminal and V)
Leakage current	0.1 mA max.	
ON delay time	0.5 ms max.	

Item	Specifications
OFF delay time	1.5 ms max.
Number of circuits	8 points with one common

**Component Names and Functions: DRT2-OD08 and DRT2-OD08-1**

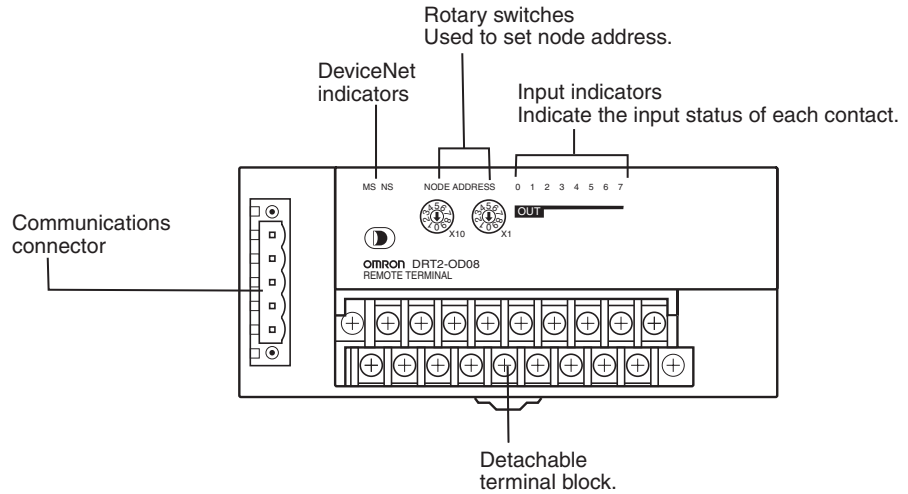

**Internal Circuits**

**DRT2-OD08 (NPN)**

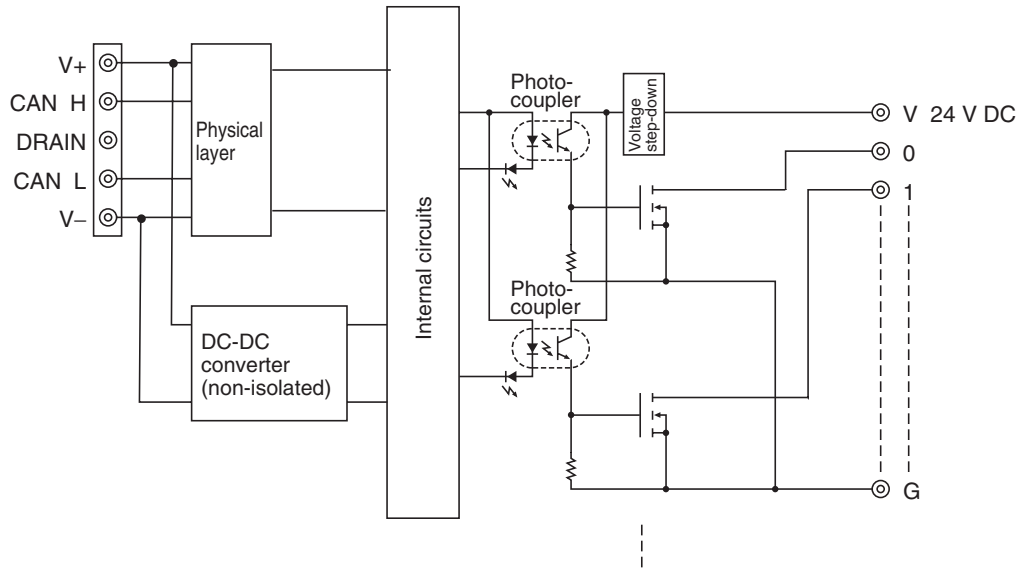

DRT2-OD08-1 (PNP)

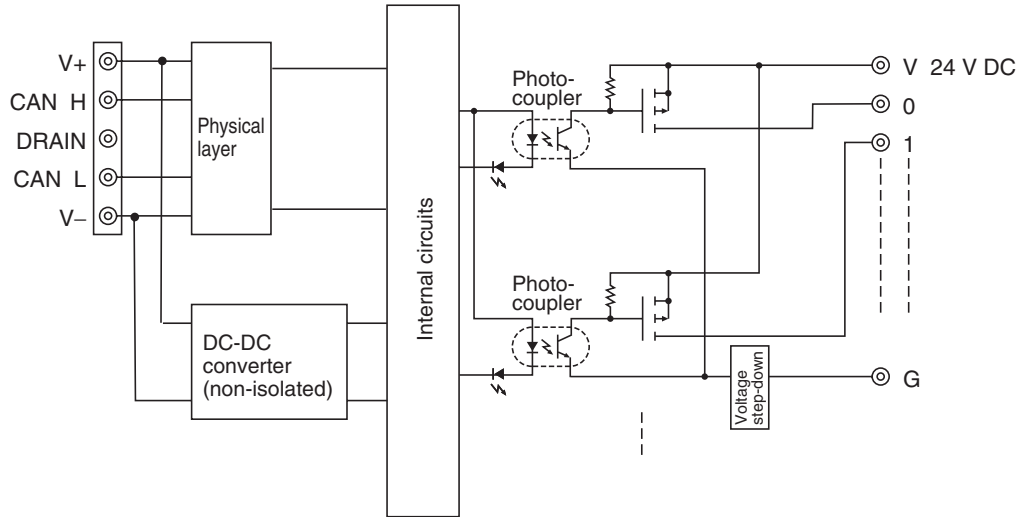

Wiring

DRT2-OD08 (NPN)

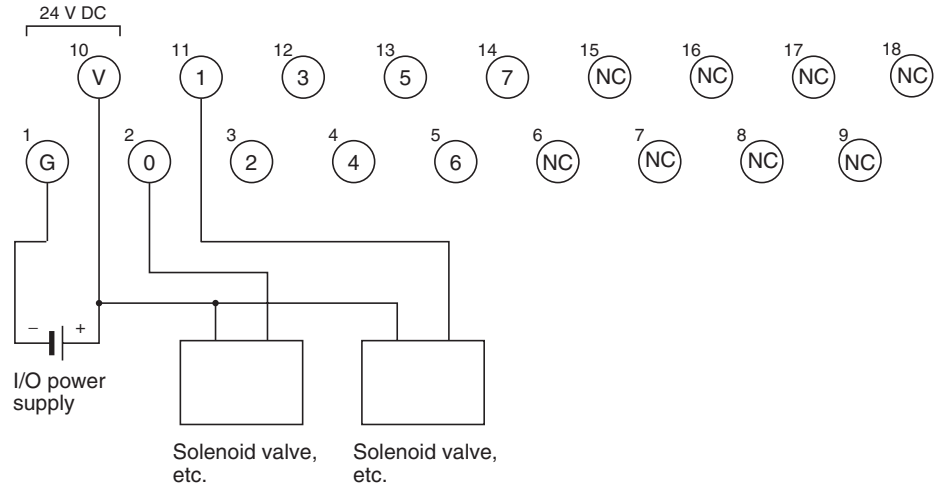

DRT2-OD08-1 (PNP)

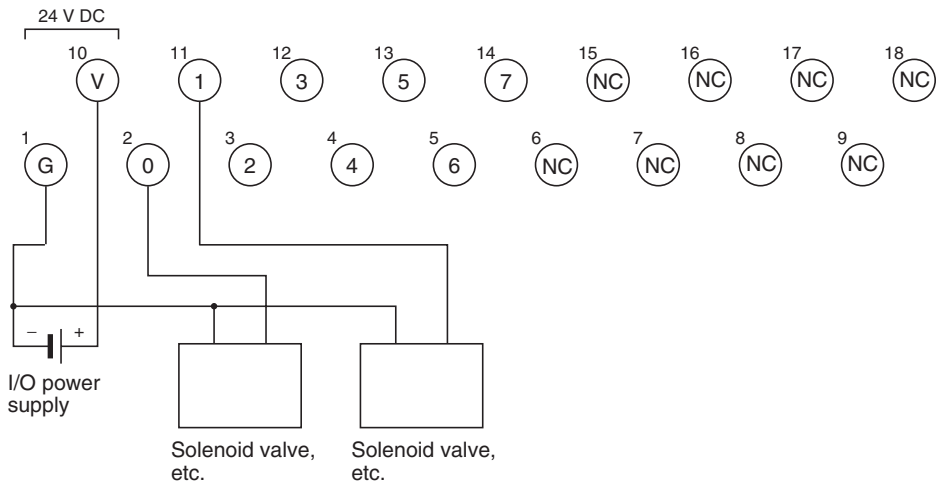

**Note** Wire colors in parentheses are the previous JIS colors for photoelectric and proximity sensors.

**Dimensions: DRT2-OD08 and DRT2-OD08-1**

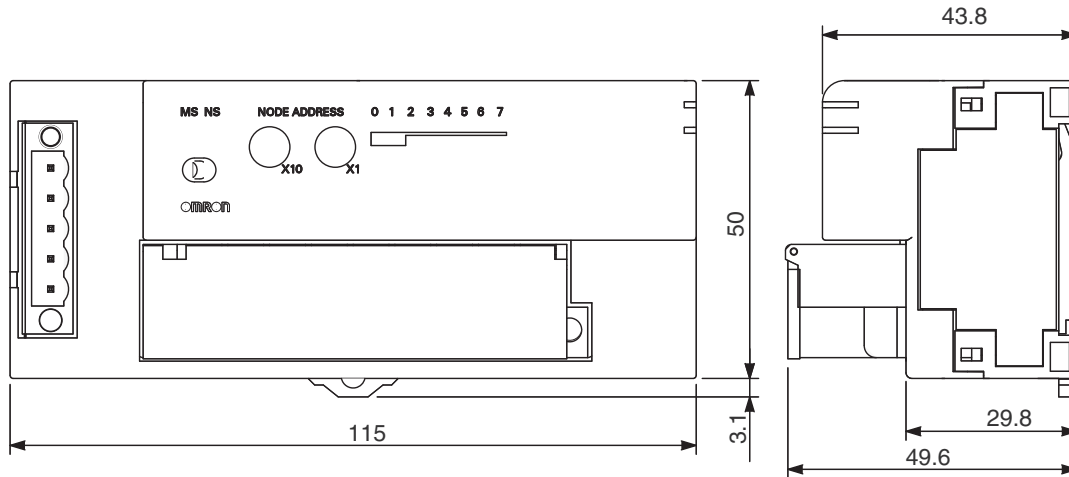

**5-5-5 Remote I/O Terminals with 16 Transistor Inputs: DRT2-ID16 (NPN) and DRT2-ID16-1 (PNP)**

**Input Specifications**

Item	Specifications	
	DRT2-ID16	DRT2-ID16-1
Model	DRT2-ID16	DRT2-ID16-1
Internal I/O common	NPN	PNP
Input points	16 points	
ON voltage	15 V DC min. (between each input terminal and V)	15 V DC min. (between each input terminal and G)
OFF voltage	5 V DC max. (between each input terminal and V)	5 V DC max. (between each input terminal and G)
OFF current	1 mA max.	
Input current	6.0 mA max./point (for 24 V DC) 3.0 mA min./point (for 17 V DC)	
ON delay time	1.5 ms max.	
OFF delay time	1.5 ms max.	
Number of circuits	16 points with one common	

**Component Names and Functions: DRT2-ID16 and DRT2-ID16-1**

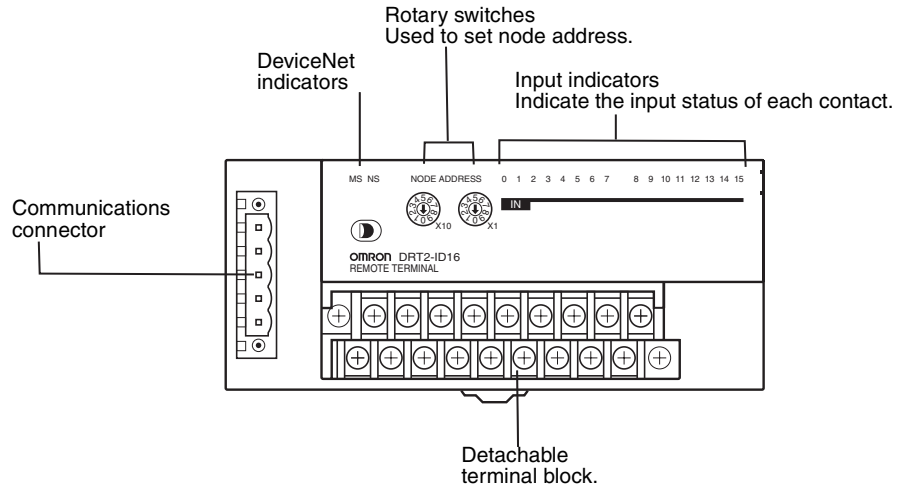

**Internal Circuits**

**DRT2-ID16 (NPN)**

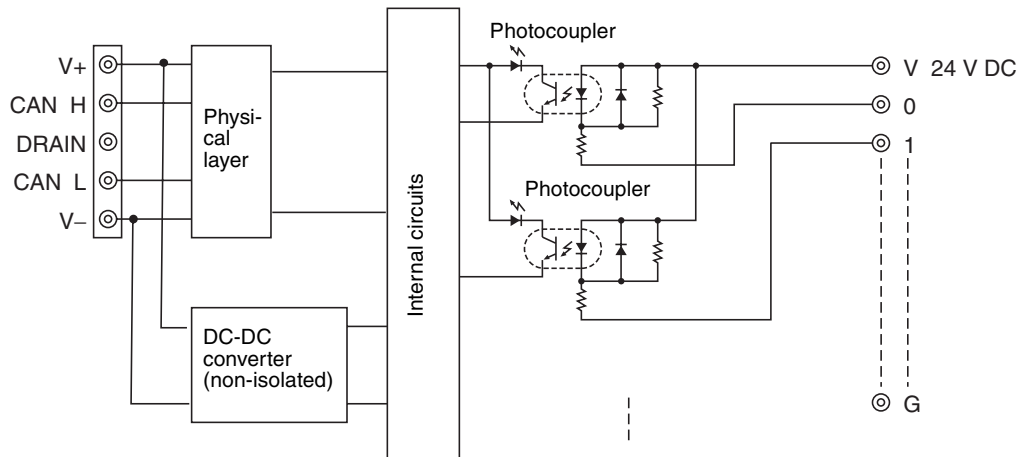

**DRT2-ID16-1 (PNP)**

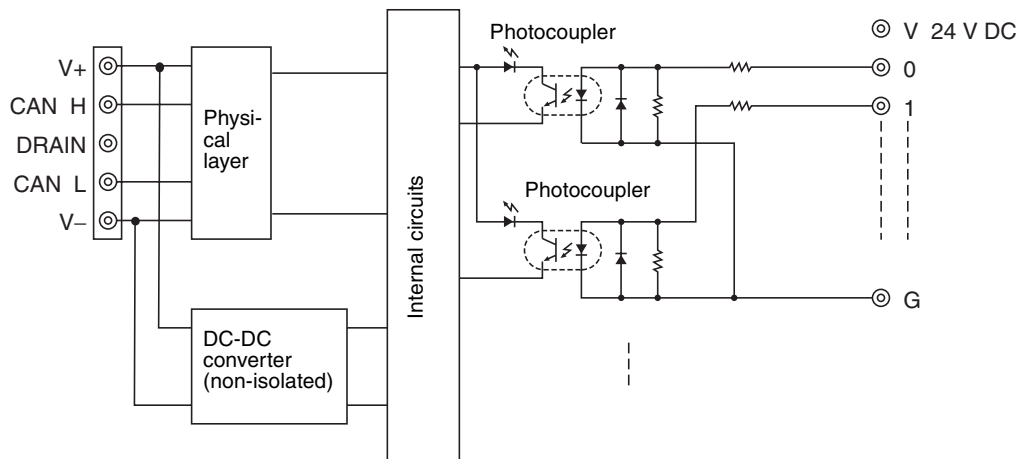

**Wiring**

**DRT2-ID16 (NPN)**

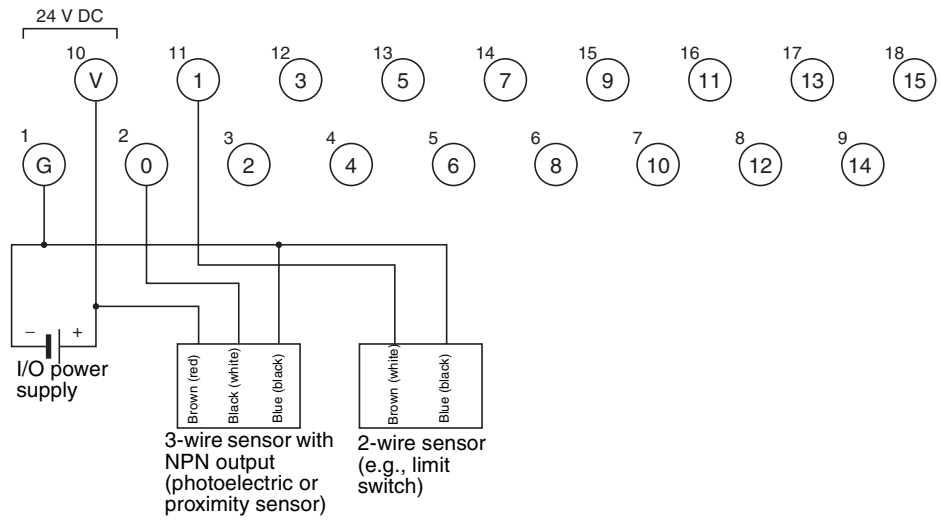

**DRT2-ID16-1 (PNP)**

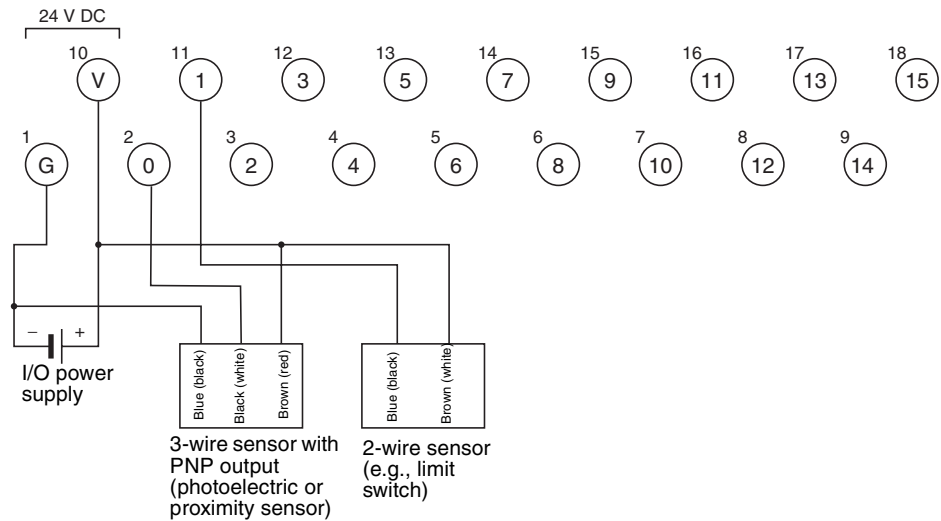

**Note** Wire colors in parentheses are the previous JIS colors for photoelectric and proximity sensors.

**Dimensions: DRT2-ID16 and DRT2-ID16-1**

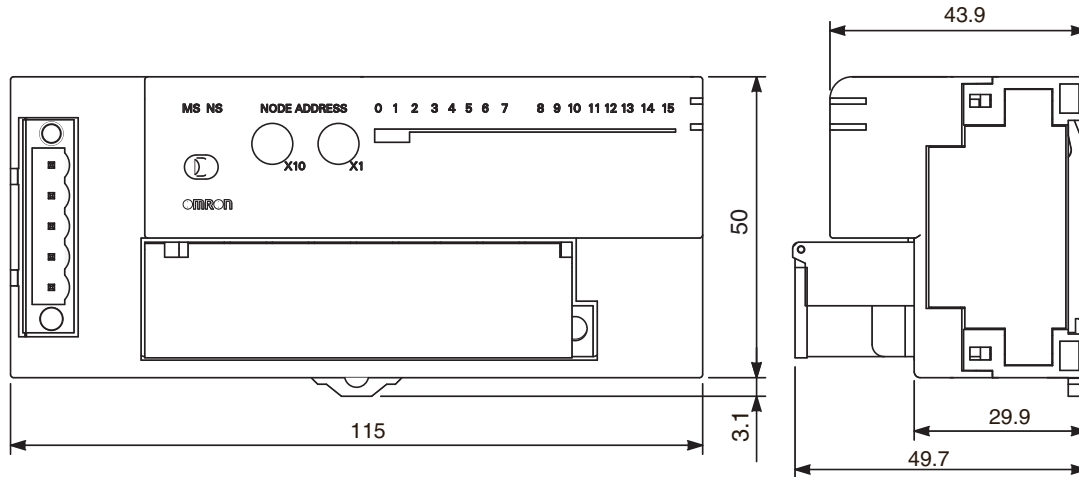

**5-5-6 Remote I/O Terminals 16 Transistor Outputs: DRT2-OD16 (NPN) and DRT2-OD16-1 (PNP)**

**Output Specifications**

Item	Specifications	
Model	DRT2-OD16	DRT2-OD16-1
Internal I/O common	NPN	PNP
Output points	16 points	
Rated output current	0.5 A/point, 4.0 A/common	
Residual voltage	1.2 V max. (at 0.5 A between each output terminal and G)	1.2 V max. (at 0.5 A between each output terminal and V)
Leakage current	0.1 mA max.	0.1 mA max.
ON delay time	0.5 ms max.	
OFF delay time	1.5 ms max.	
Number of circuits	16 points with one common	

**Component Names and Functions: DRT2-OD16 and DRT2-OD16-1**

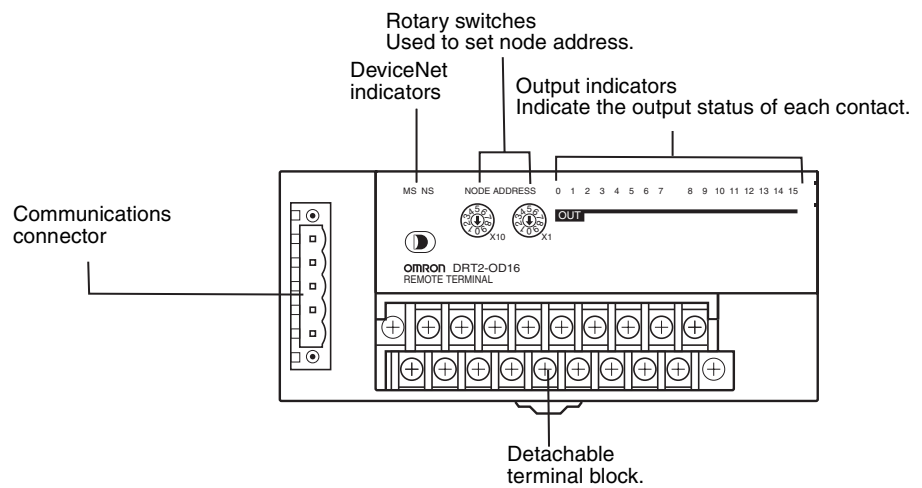

Internal Circuits

DRT2-OD16 (NPN)

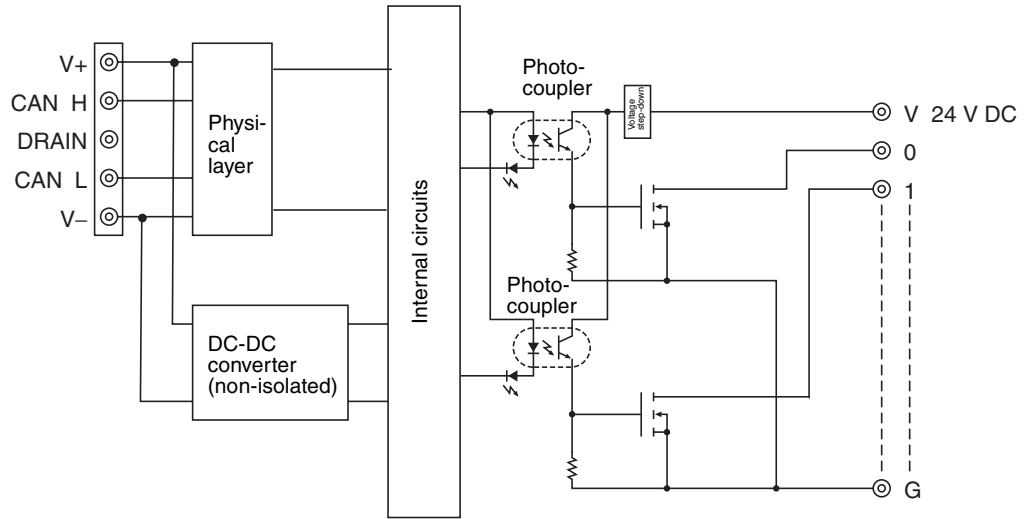

DRT2-OD16-1 (PNP)

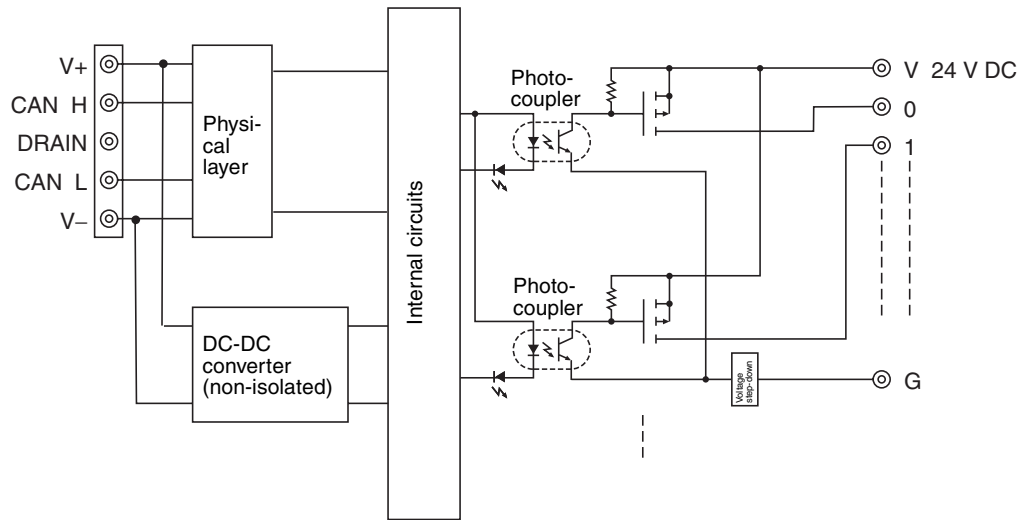



**Wiring**

**DRT2-OD16 (NPN)**

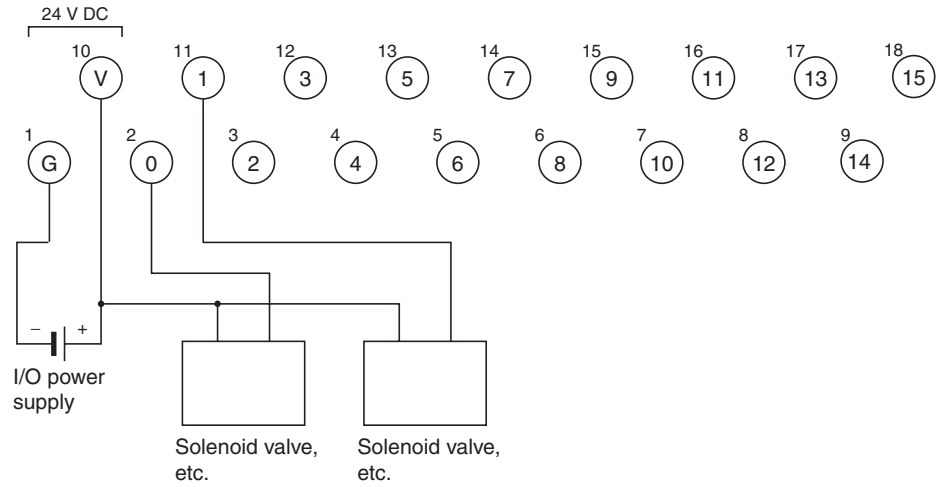

**DRT2-OD16-1 (PNP)**

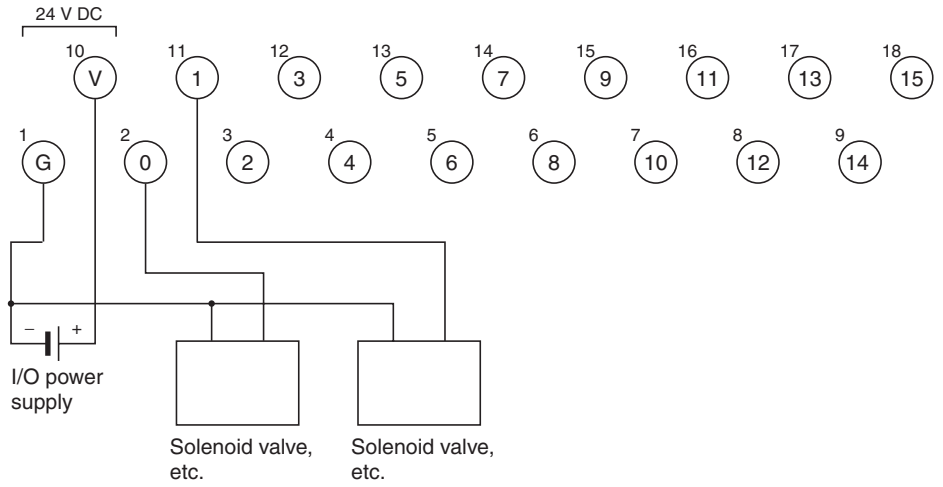

**Note** Wire colors in parentheses are the previous JIS colors for photoelectric and proximity sensors.

**Dimensions: DRT2-OD16 and DRT2-OD16-1**

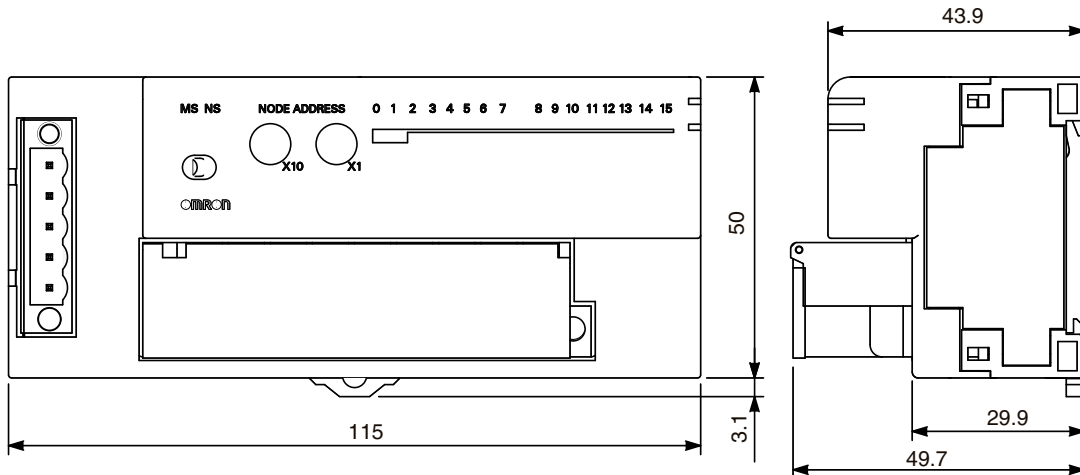

### 5-5-7 Remote I/O Terminals with 8 Transistor Inputs and 8 Transistor Outputs: DRT2-MD16 (NPN) and DRT2-MD16-1 (PNP)

#### Input Specifications

Item	Specifications	
Model	DRT2-MD16	DRT2-MD16-1
Internal I/O common	NPN	PNP
Input points	8 points	
ON voltage	15 V DC min. (between each input terminal and V)	15 V DC min. (between each input terminal and G)
OFF voltage	5 V DC max. (between each input terminal and V)	5 V DC max. (between each input terminal and G)
OFF current	1 mA max.	
Input current	6.0 mA max./point (for 24 V DC) 3.0 mA min./point (for 17 V DC)	
ON delay time	1.5 ms max.	
OFF delay time	1.5 ms max.	
Number of circuits	8 points with one common	

#### Output Specifications

Item	Specifications	
Model	DRT2-MD16	DRT2-MD16-1
Internal I/O common	NPN	PNP
Output points	8 points	
Rated output current	0.5 A/point, 4.0 A/common	
Residual voltage	1.2 V max. (at 0.5 A between each output terminal and G)	1.2 V max. (at 0.5 A between each output terminal and V)
Leakage current	0.1 mA max.	0.1 mA max.
ON delay time	0.5 ms max.	
OFF delay time	1.5 ms max.	
Number of circuits	8 points with one common	

#### Component Names and Functions: DRT2-MD16 and DRT2-MD16-1

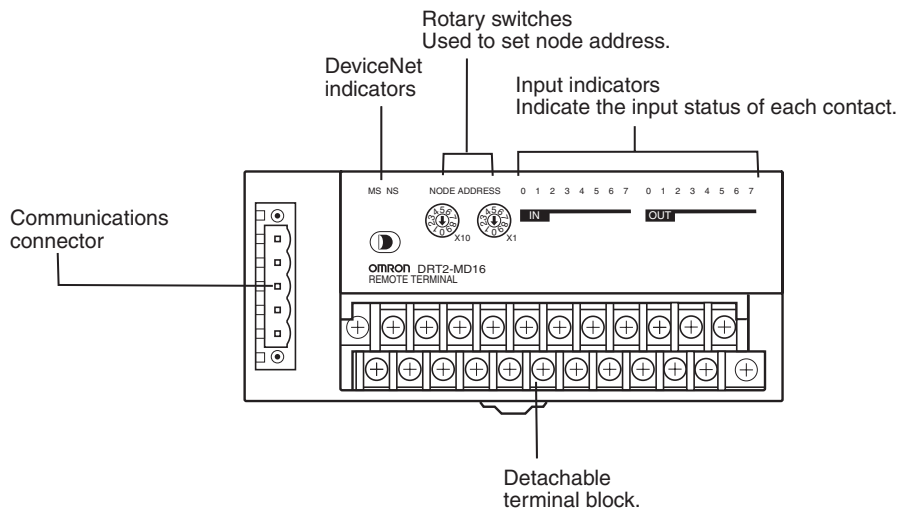

**Internal Circuits**

**DRT2-MD16 (NPN)**

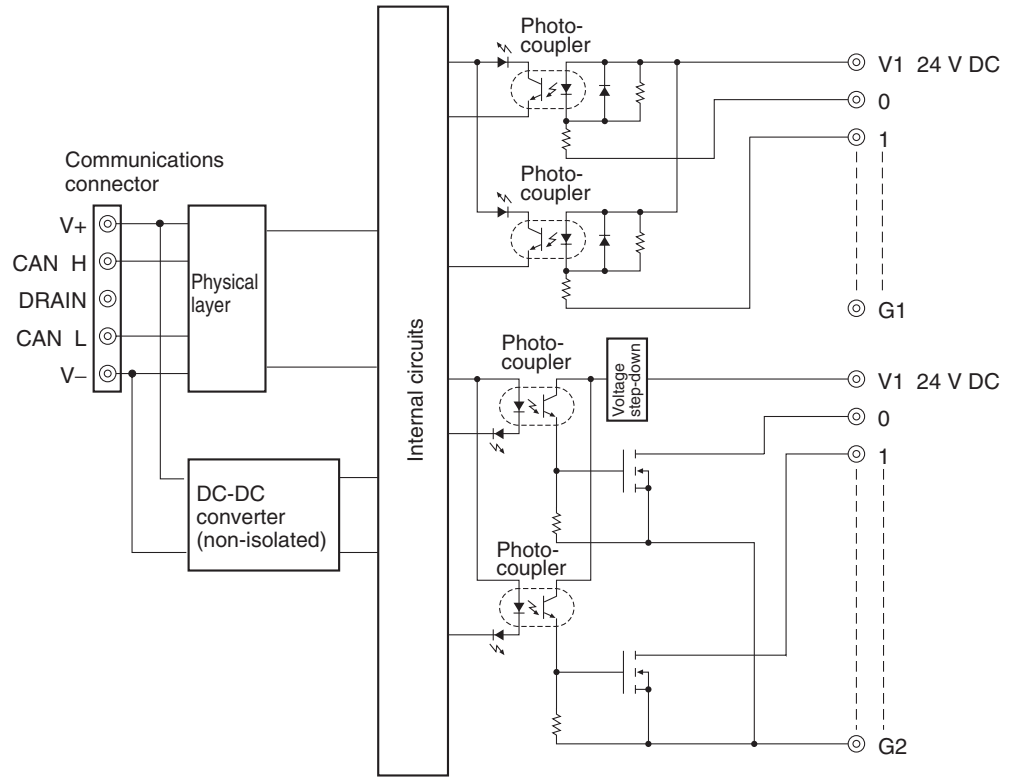

**DRT2-MD16-1 (PNP)**

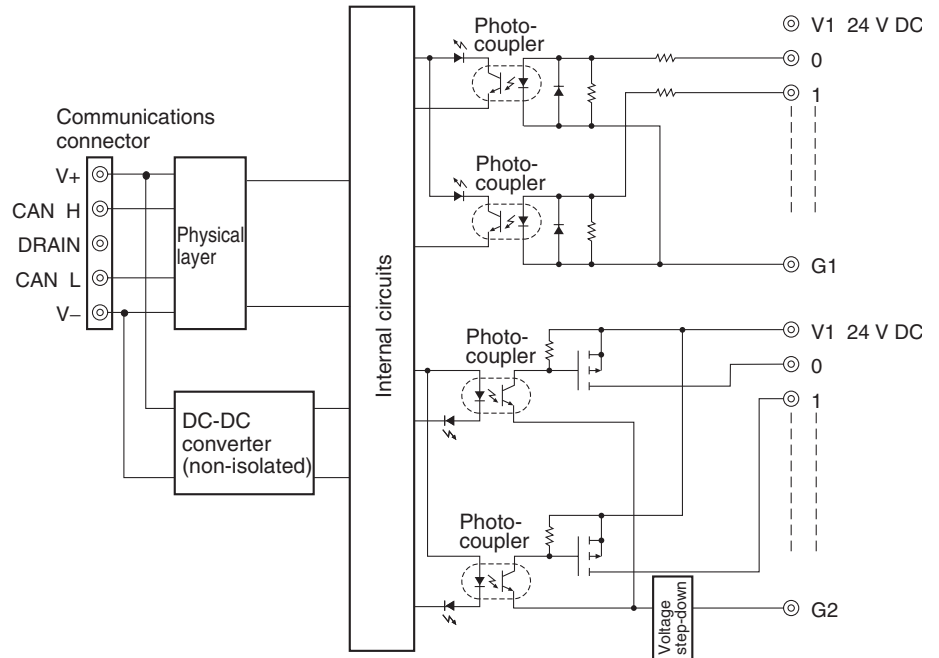

**Wiring**

**DRT2-MD16 (NPN)**

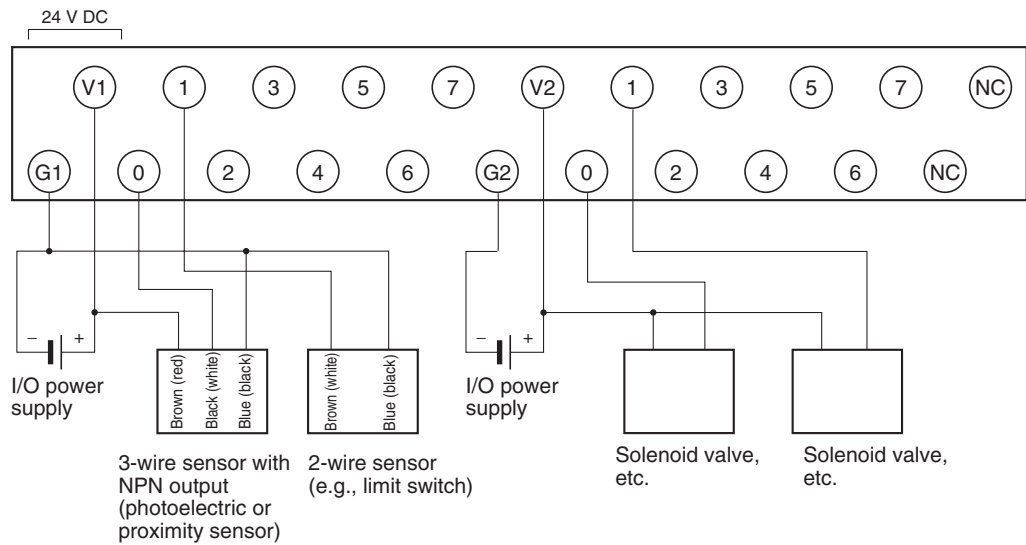

**DRT2-MD16-1 (PNP)**

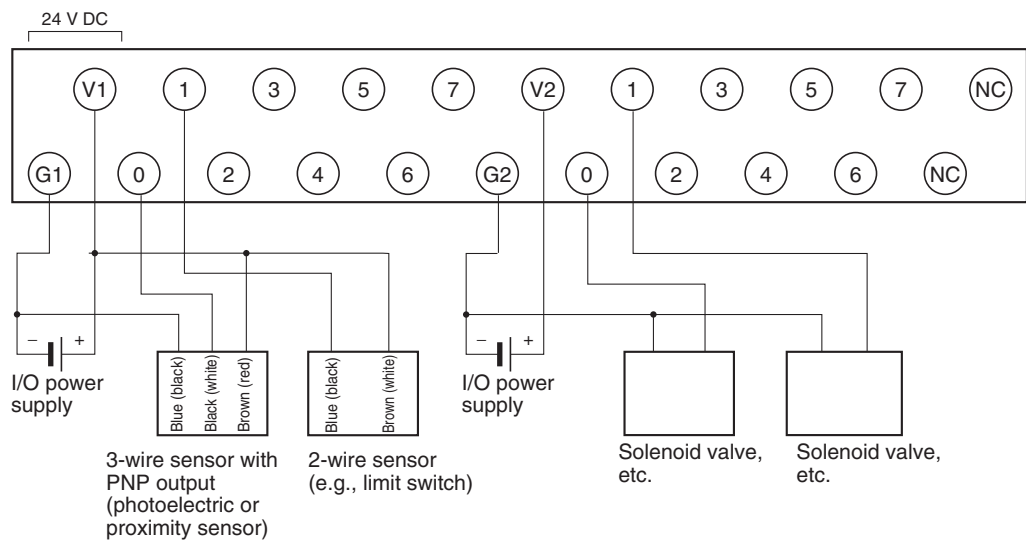

**Note** Wire colors in parentheses are the previous JIS colors for photoelectric and proximity sensors.

**Dimensions: DRT2-MD16 and DRT2-MD16-1**

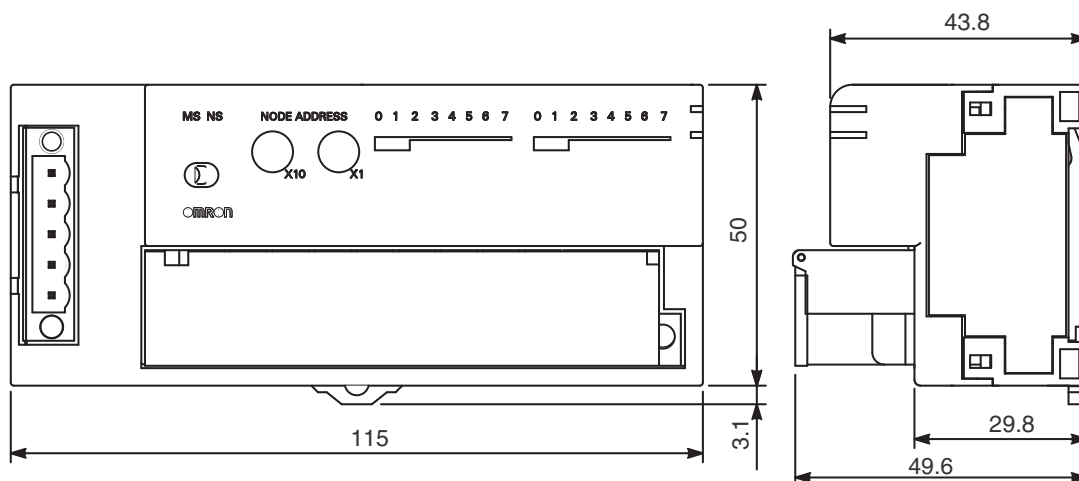

**5-5-8 Remote I/O Terminal with 16 Relay Outputs: DRT2-ROS16**

**Common Specifications**

Item	Specifications
Communications power supply voltage	11 to 25 V DC (Supplied from the communications connector.)
Noise immunity	Conforms to IEC61000-4-4. 2 kV (power lines)
Vibration resistance	10 to 55 Hz, 0.7-mm double amplitude
Shock resistance	100 m/s <sup>2</sup>
Dielectric strength	500 V AC (between isolated circuits)
Insulation resistance	20 MΩ min. at 250 V DC
Ambient temperature	-10 to +55°C
Ambient humidity	25% to 85% (with no condensation)
Operating environment	No corrosive gases
Storage temperature	-25 to +65°C
Mounting	35-mm DIN Track mounting
Screw tightening torque	M2 (communications connector lock screws): 0.26 to 0.3 N·m M3 wiring screws: 0.5 N·m M3 mounting screws: 0.5 N·m

**Output Specifications (for One Relay)**

Item	Specifications
Relay	DRTA-NY5W-K
Rated load	Resistive load 250 V AC, 2 A, 8-A common 30 V DC, 2 A, 8-A common
Rated carry current	3 A (See note.)
Maximum switching voltage	250 V AC, 125 V DC
Maximum switching current	3 A

Item	Specifications
Maximum switching capacity	750 V AC, 90 V DC
Minimum applicable load (reference value)	5 V DC at 1 mA

**Note** The rated carry current can be as high as 3 A (10-A common) if the number of terminals that turn ON simultaneously is four or less per common, or if the ambient temperature is 45°C or lower.

**Relay Life Expectancy**

Item	Specifications
Mechanical life expectancy	20,000,000 times min.
Electrical life expectancy	100,000 times min.

**Component Names and Functions**

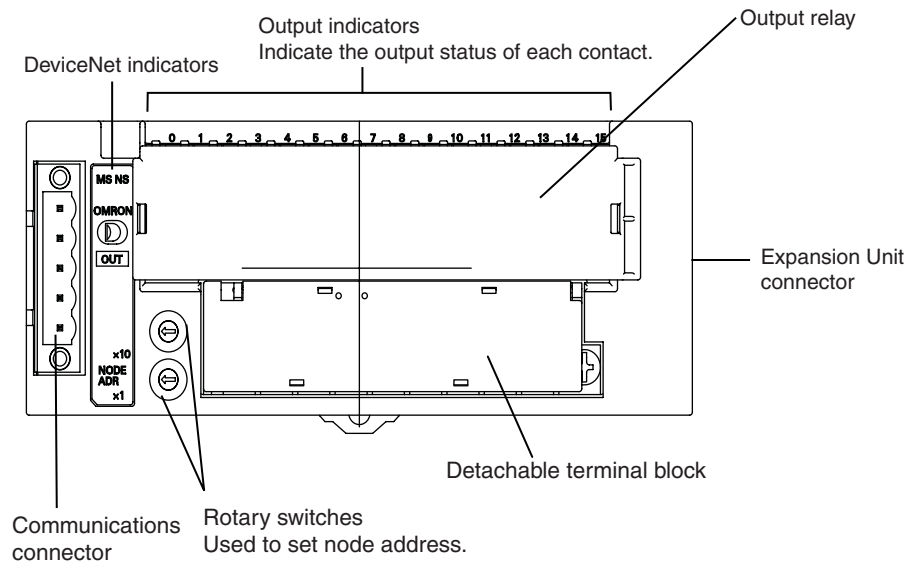

**Internal Circuits**

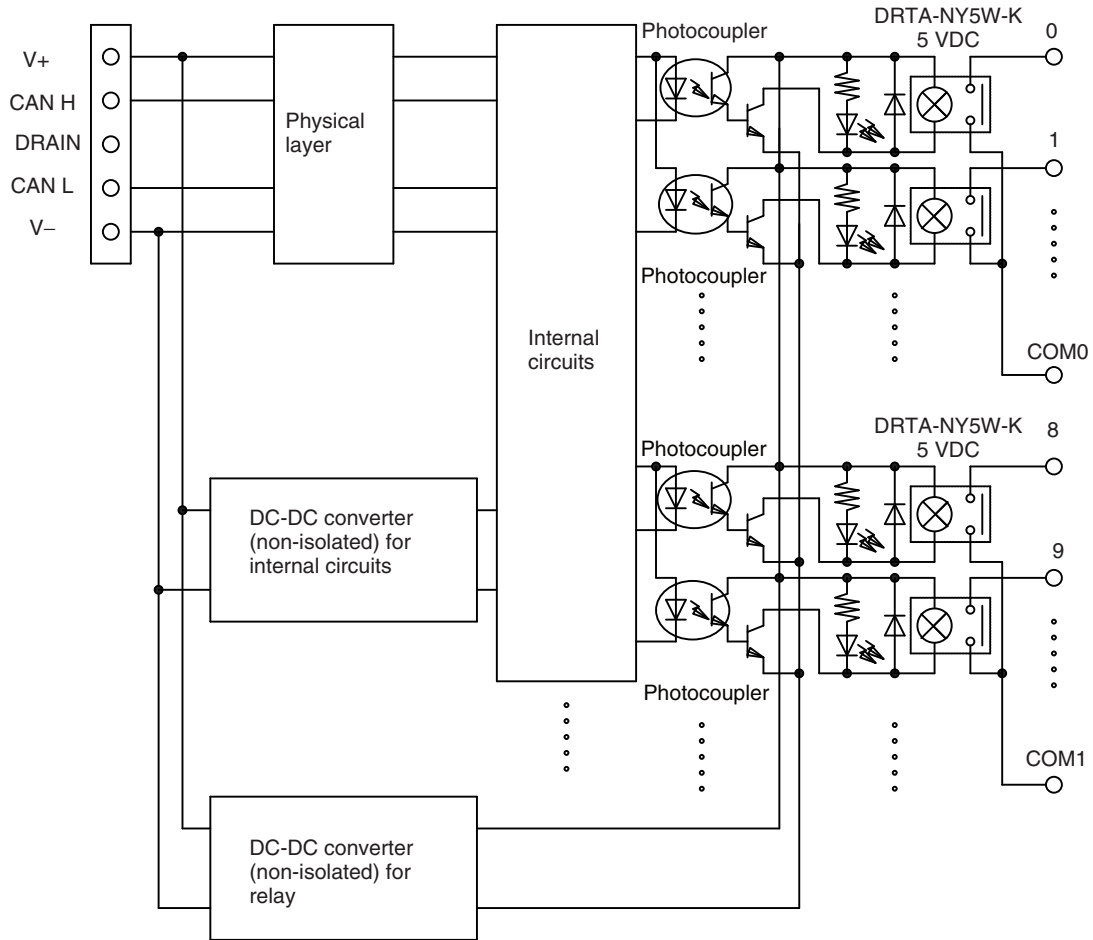

**Wiring**

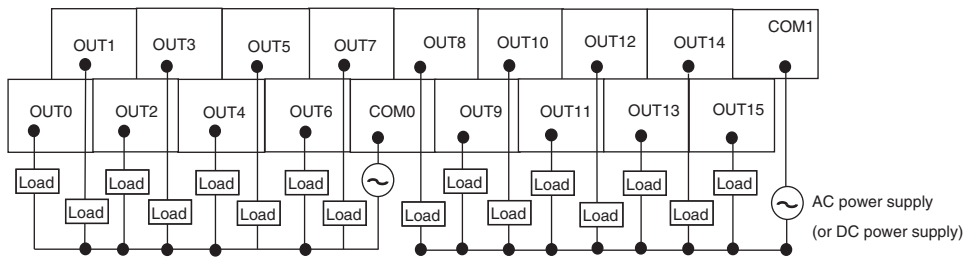

**Dimensions**

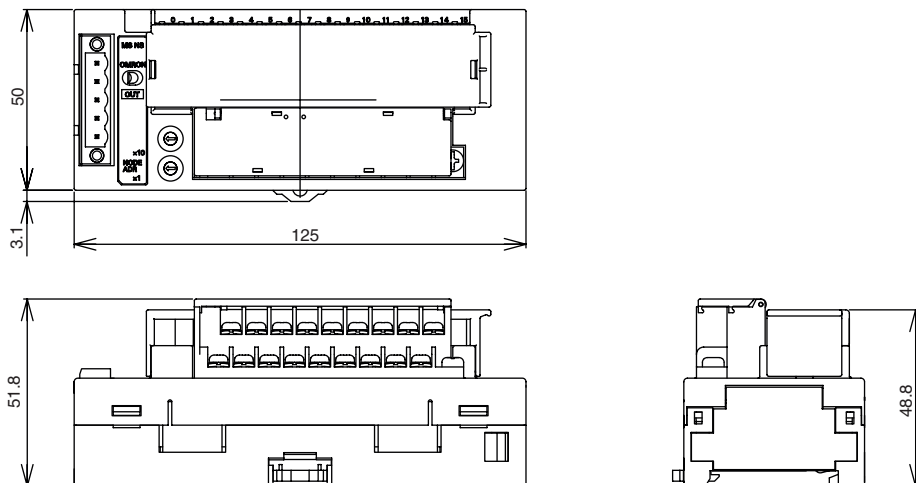

**Reference Data**

The data shown below is based on actual measurements of samples taken from the production line. There is some degree of variation in relay characteristics and so this data should be used only for reference purposes.

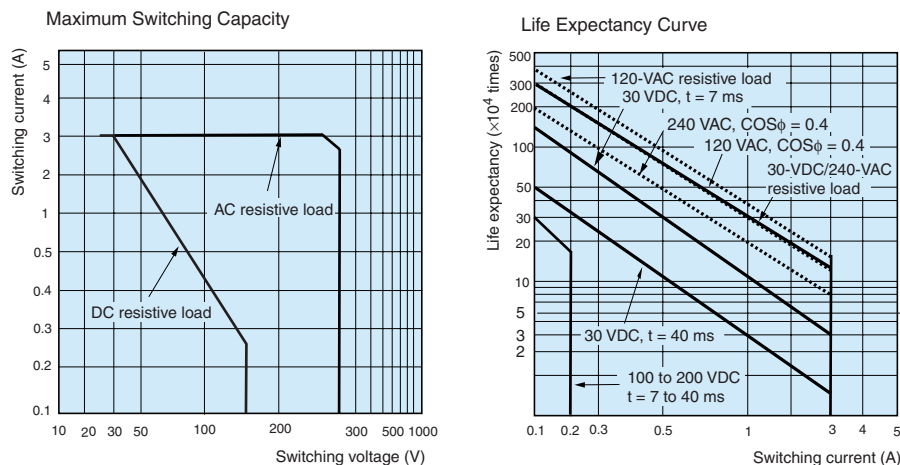

- Note**
1. With a current of between 2 and 3 A (common: 8 to 10 A), either ensure that the number of points per common that simultaneously turn ON does not exceed 4 or ensure that the temperature does not exceed 45°C. There are no restrictions if the current does not exceed 2 A (common: 8 A).
  2. Using at the rated current value assures normal Unit operation but does not assure the life expectancy of the relay itself. The relay's life expectancy varies greatly with the operating temperature, type of load, and switching conditions, and so be sure to check the relay characteristics under the actual operating conditions.



**Relay Replacement Method**

When replacing output relays, remove the cover as shown below.

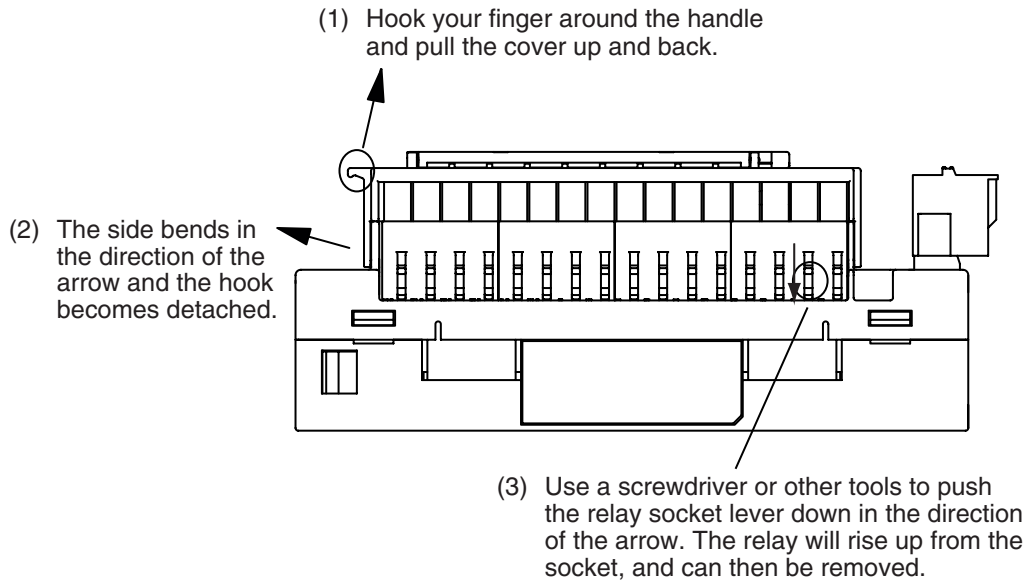

**5-5-9 Remote I/O Terminal Expansion Units with 8 Transistor Inputs: XWT-ID08 (NPN) and XWT-ID08-1 (PNP)**

**Input Specifications**

Item	Specifications	
Model	XWT-ID08	XWT-ID08-1
Internal I/O common	NPN	PNP
Input points	8 points	
ON voltage	15 V DC min. (between each input terminal and V)	15 V DC min. (between each input terminal and G)
OFF voltage	5 V DC max. (between each input terminal and V)	5 V DC max. (between each input terminal and G)
OFF current	1 mA max.	
Input current	6.0 mA max./point (for 24 V DC) 3.0 mA min./point (for 17 V DC)	
ON delay time	1.5 ms max.	
OFF delay time	1.5 ms max.	
Number of circuits	8 points with one common	

**Component Names and Functions: XWT-ID08 and XWT-ID08-1**

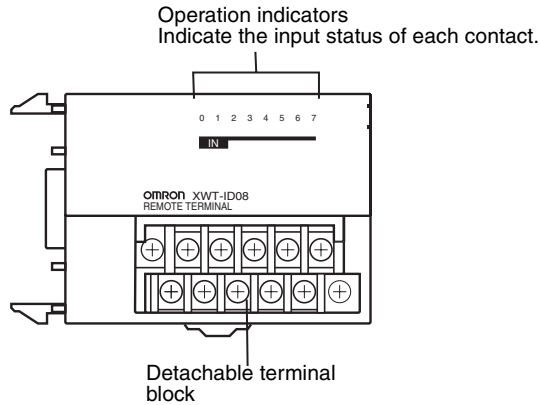

**Operation Indicators**

The operation indicators show the status of the inputs.

Indicator name	Indicator status	Definition	Meaning	
0 to 7	Lit yellow.		Contacts ON	Contacts are ON
	OFF		Contacts OFF	Contacts are OFF

**Internal Circuits**

**XWT-ID08 (NPN)**

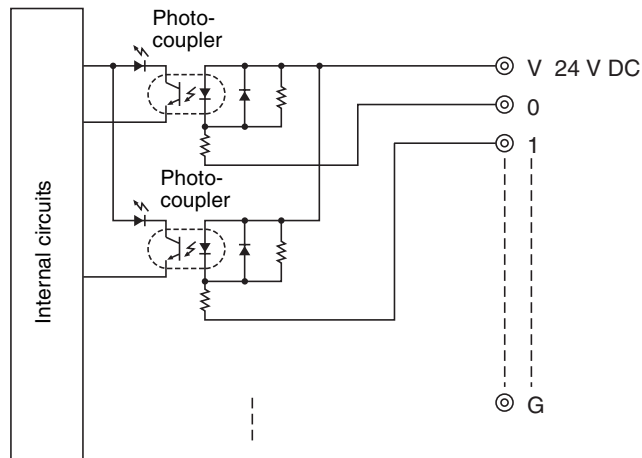

**XWT-ID08-1 (PNP)**

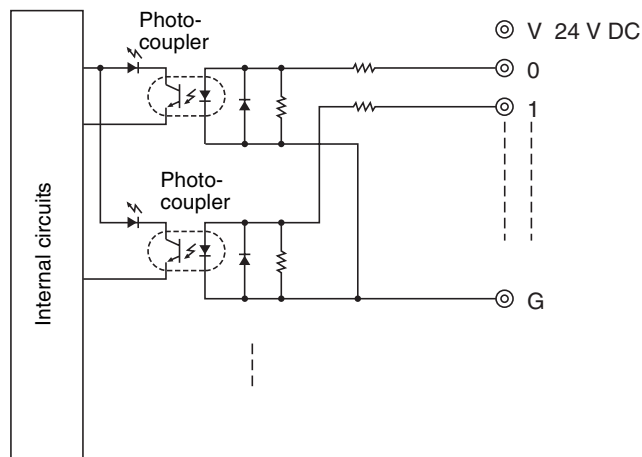

**Wiring**

**XWT-ID08 (NPN)**

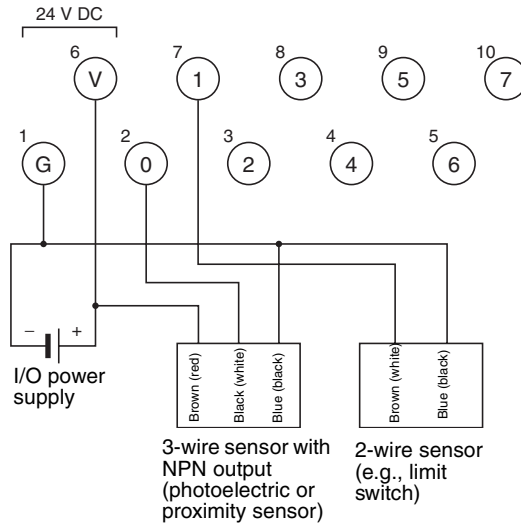

**XWT-ID08-1 (PNP)**

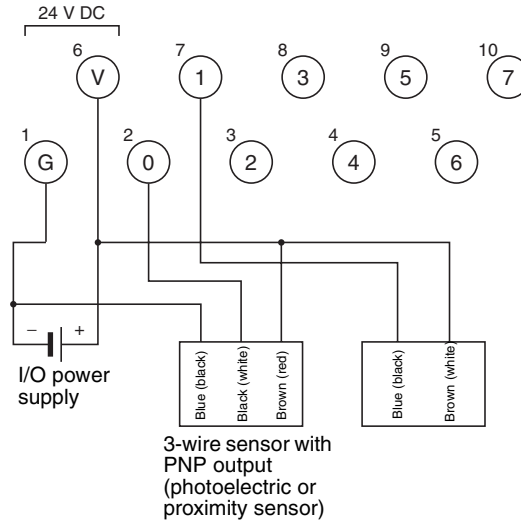

**Dimensions: XWT-ID08 and XWT-ID08-1**

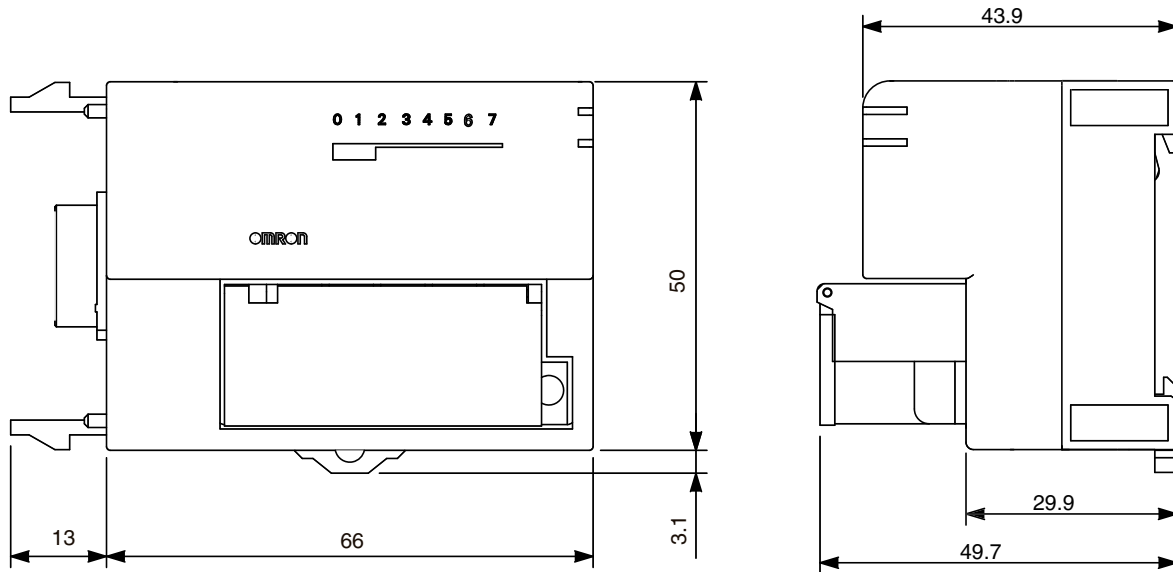

**5-5-10 Remote I/O Terminal Expansion Units 16 Transistor Inputs: XWT-ID16 (NPN) and XWT-ID16-1 (PNP)**

**Input Specifications**

Item	Specifications	
	XWT-ID16	XWT-ID16-1
Model	XWT-ID16	XWT-ID16-1
Internal I/O common	NPN	PNP
Input points	16 points	
ON voltage	15 V DC min. (between each input terminal and V)	15 V DC min. (between each input terminal and G)
OFF voltage	5 V DC max. (between each input terminal and V)	5 V DC max. (between each input terminal and G)
OFF current	1 mA max.	
Input current	6.0 mA max./point (for 24 V DC) 3.0 mA min./point (for 17 V DC)	
ON delay time	1.5 ms max.	
OFF delay time	1.5 ms max.	
Number of circuits	16 points with one common	

**Component Names and Functions: XWT-ID16 and XWT-ID16-1**

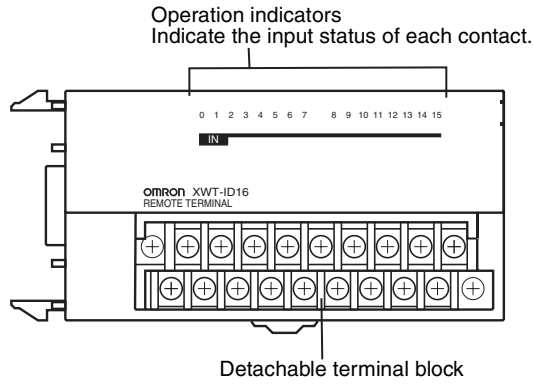

**Operation Indicators**

The operation indicators show the status of the inputs.

Indicator name	Indicator status	Definition	Meaning	
0 to 15	Lit yellow.		Contacts ON	Contacts are ON
	OFF		Contacts OFF	Contacts are OFF

**Internal Circuits**

**XWT-ID16 (NPN)**

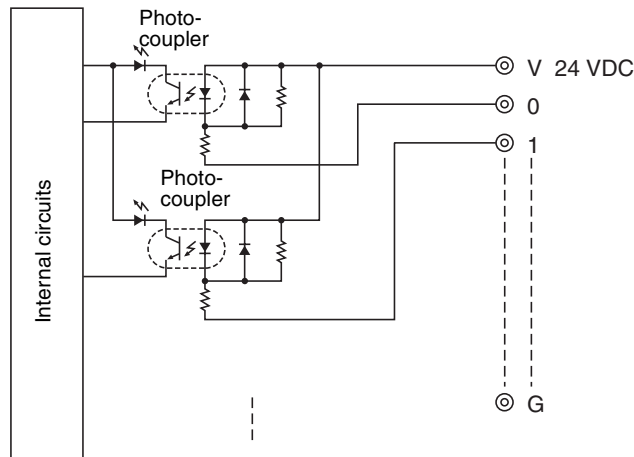

**XWT-ID16-1 (PNP)**

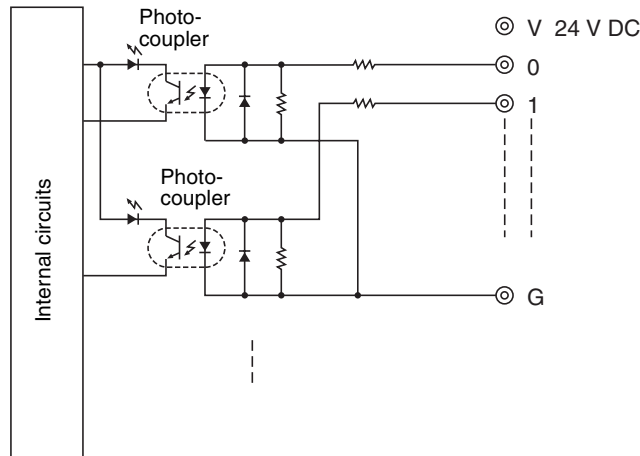

**Wiring**

**XWT-ID16 (NPN)**

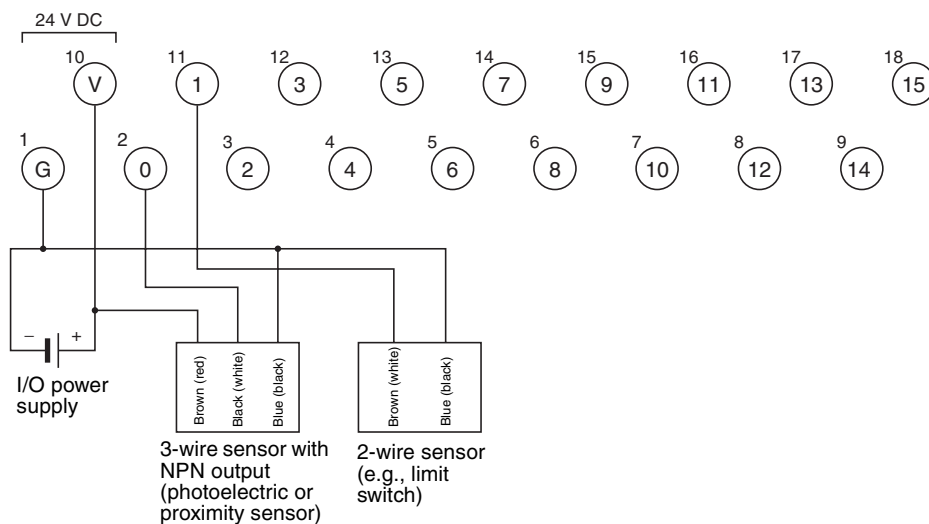

**XWT-ID16-1 (PNP)**

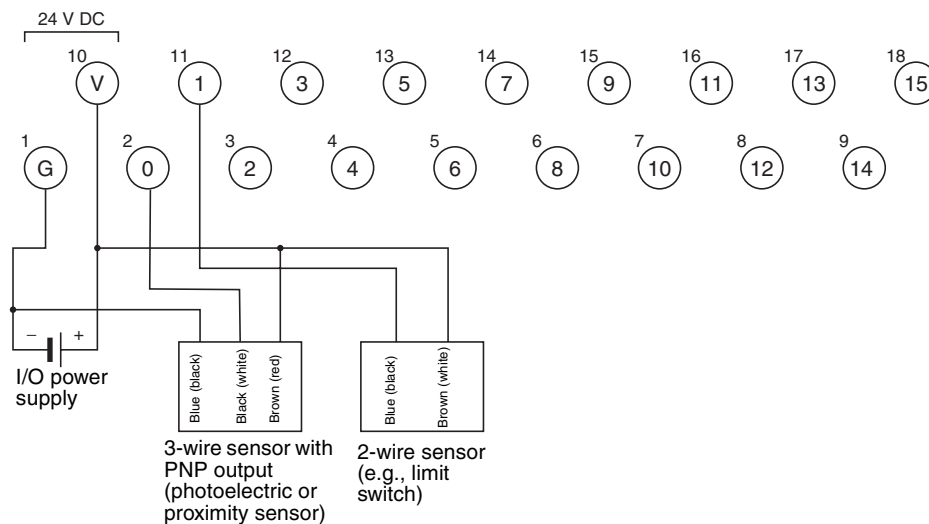

**Dimensions: XWT-ID16 and XWT-ID16-1**

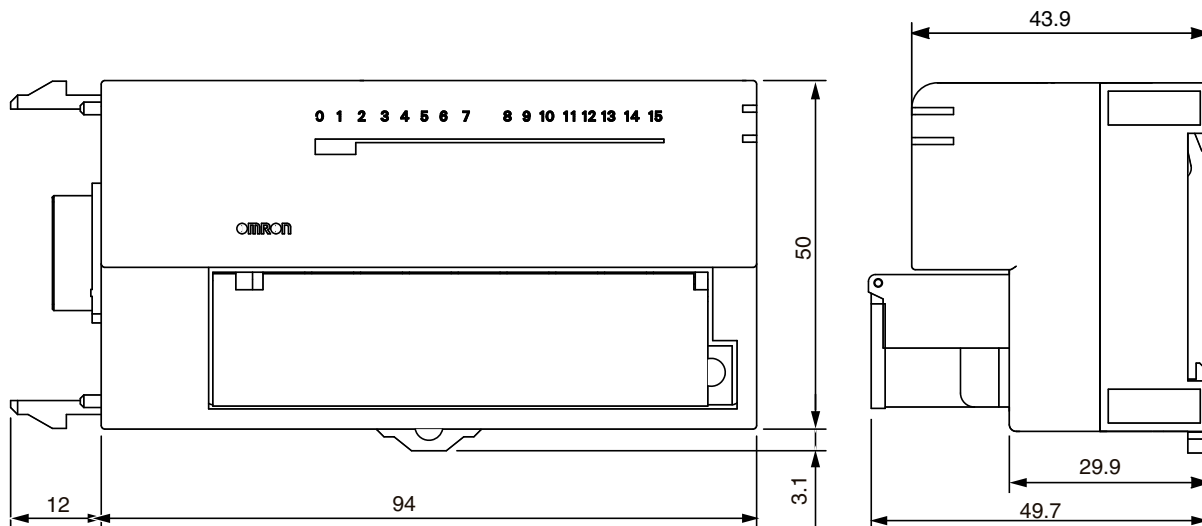

### 5-5-11 Remote I/O Terminal Expansion Units with 8 Transistor Outputs: XWT-OD08 (NPN) and XWT-OD08-1 (PNP)

#### Output Specifications

Item	Specifications	
Model	XWT-OD08	XWT-OD08-1
Internal I/O common	NPN	PNP
Output points	8 points	
Rated output current	0.5 A/point, 2.0 A/common	
Residual voltage	1.2 V max. (at 0.5 A between each output terminal and G)	1.2 V max. (at 0.5 A between each output terminal and V)
Leakage current	0.1 mA max.	0.1 mA max.
ON delay time	0.5 ms max.	
OFF delay time	1.5 ms max.	
Number of circuits	8 points with one common	

#### Component Names and Functions: XWT-OD08 and XWT-OD08-1

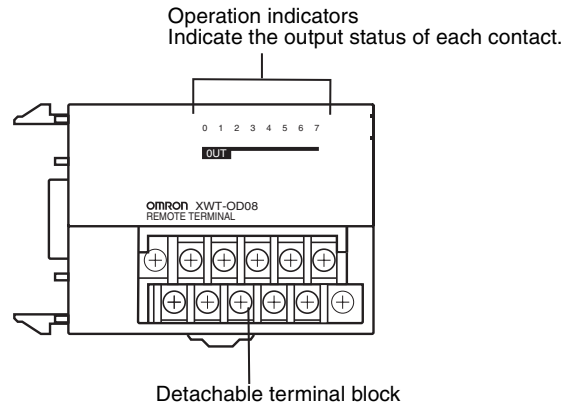

#### Operation Indicators

The operation indicators show the status of the outputs.

Indicator name	Indicator status	Definition	Meaning
0 to 7	Lit yellow.	Contacts ON	Contacts are ON
	OFF	Contacts OFF	Contacts are OFF

**Internal Circuits**

**XWT-OD08 (NPN)**

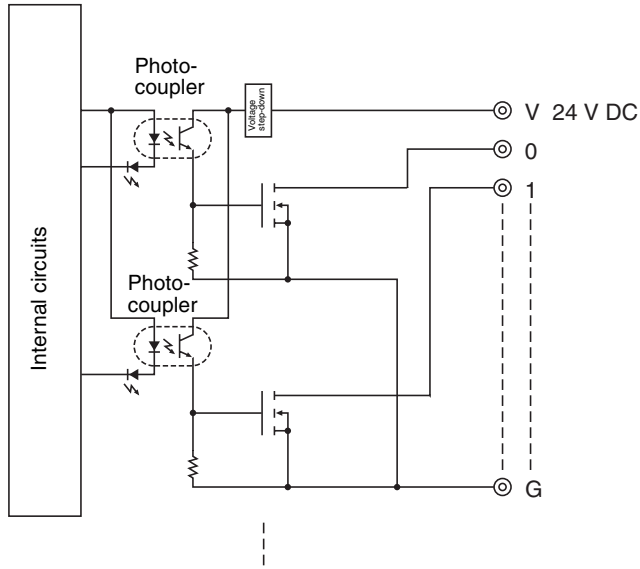

**XWT-OD08-1 (PNP)**

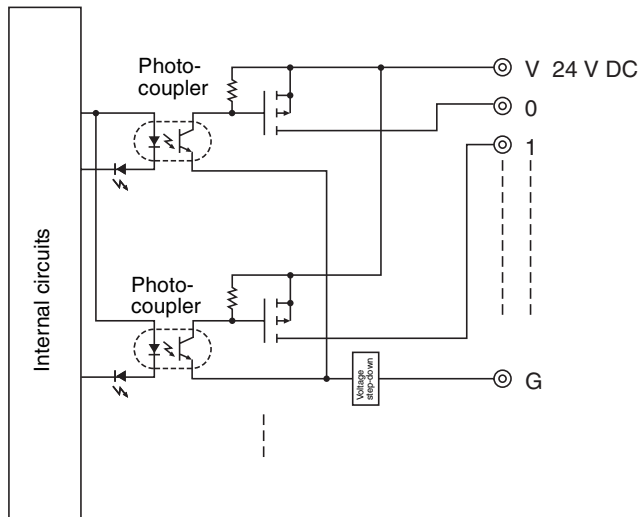



**Wiring**

**XWT-OD08 (NPN)**

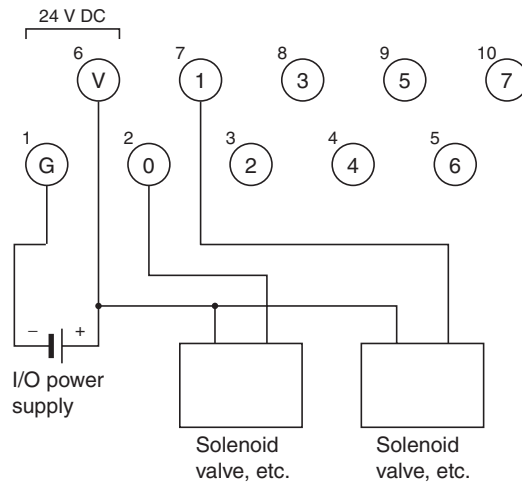

**XWT-OD08-1 (PNP)**

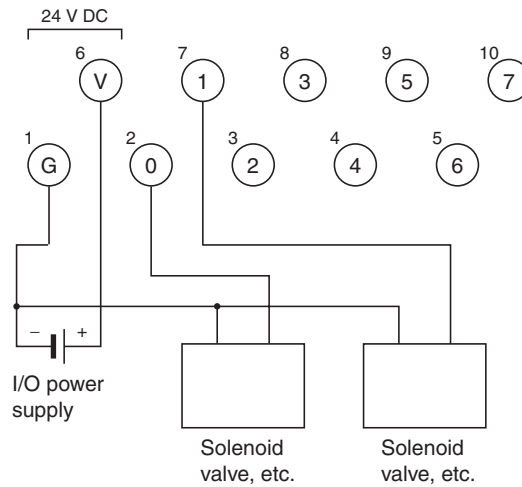

**Note** When using an inductive load, such as a solenoid valve, either use a built-in diode to absorb the counterelectromotive force or install an external diode.

**Dimensions: XWT-OD08 and XWT-OD08-1**

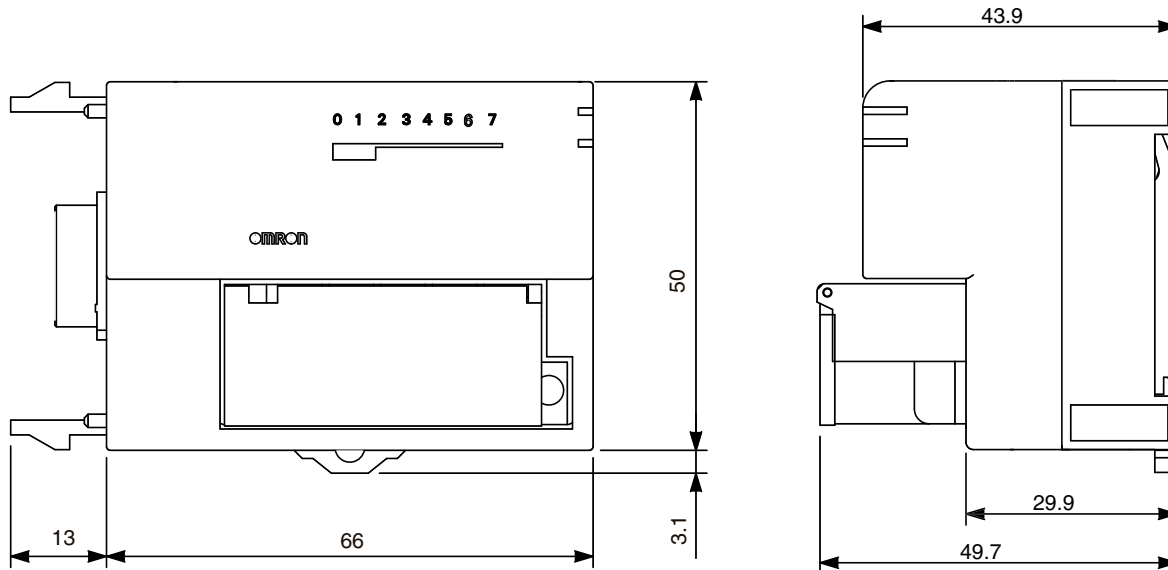

**5-5-12 Remote I/O Terminal Expansion Units with 16 Transistor Outputs: XWT-OD16 (NPN) and XWT-OD16-1 (PNP)**

**Output Specifications**

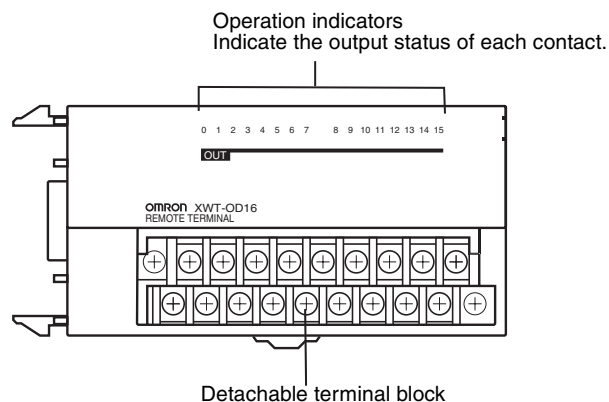

Item	Specifications	
Model	XWT-OD16	XWT-OD16-1
Internal I/O common	NPN	PNP
Output points	16 points	
Rated output current	0.5 A/point, 4.0 A/common	
Residual voltage	1.2 V max. (at 0.5 A between each output terminal and G)	1.2 V max. (at 0.5 A between each output terminal and V)
Leakage current	0.1 mA max.	0.1 mA max.
ON delay time	0.5 ms max.	
OFF delay time	1.5 ms max.	
Number of circuits	16 points with one common	

**Component Names and Functions: XWT-OD16 and XWT-OD16-1**



**Operation Indicators**

The operation indicators show the status of the outputs.

Indicator name	Indicator status	Definition	Meaning	
0 to 15	Lit yellow.		Contacts ON	Contacts are ON
	OFF		Contacts OFF	Contacts are OFF

**Internal Circuits**

**XWT-OD16 (NPN)**

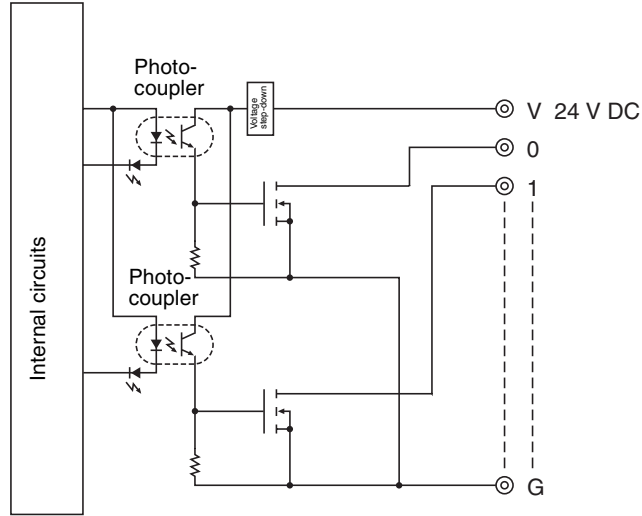

**XWT-OD16-1 (PNP)**

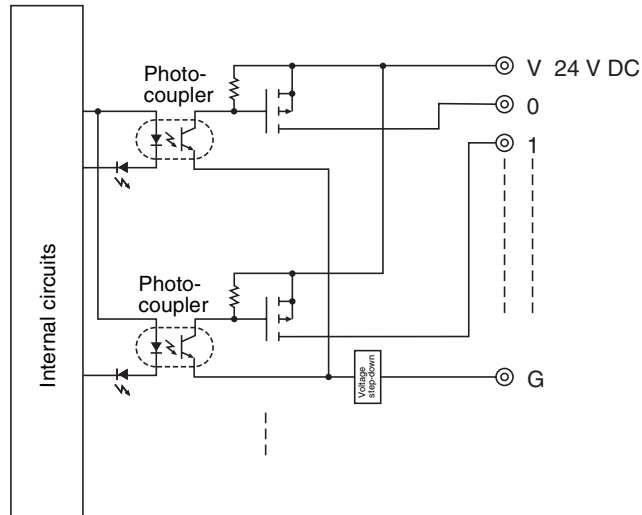

**Wiring**

**XWT-OD16 (NPN)**

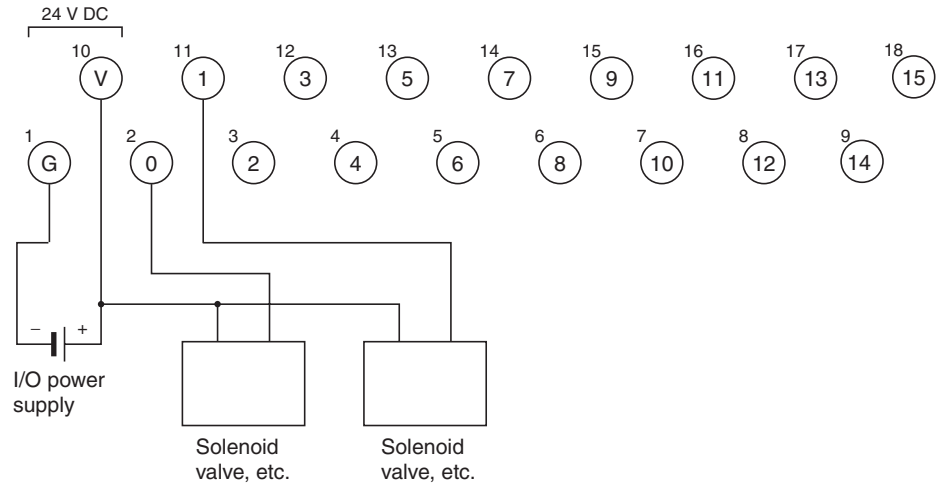

**XWT-OD16-1 (PNP)**

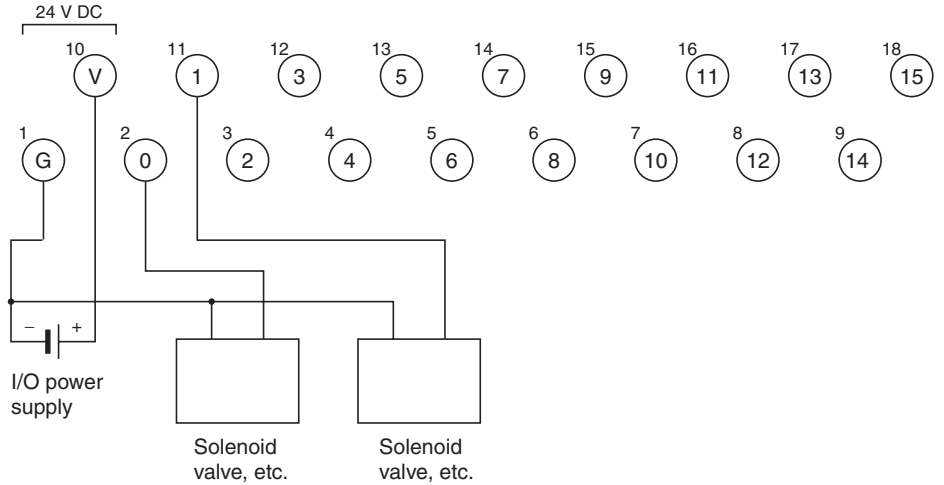

**Note** When using an inductive load, such as a solenoid valve, either use a built-in diode to absorb the counterelectromotive force or install an external diode.

**Dimensions: XWT-OD16 and XWT-OD16-1**

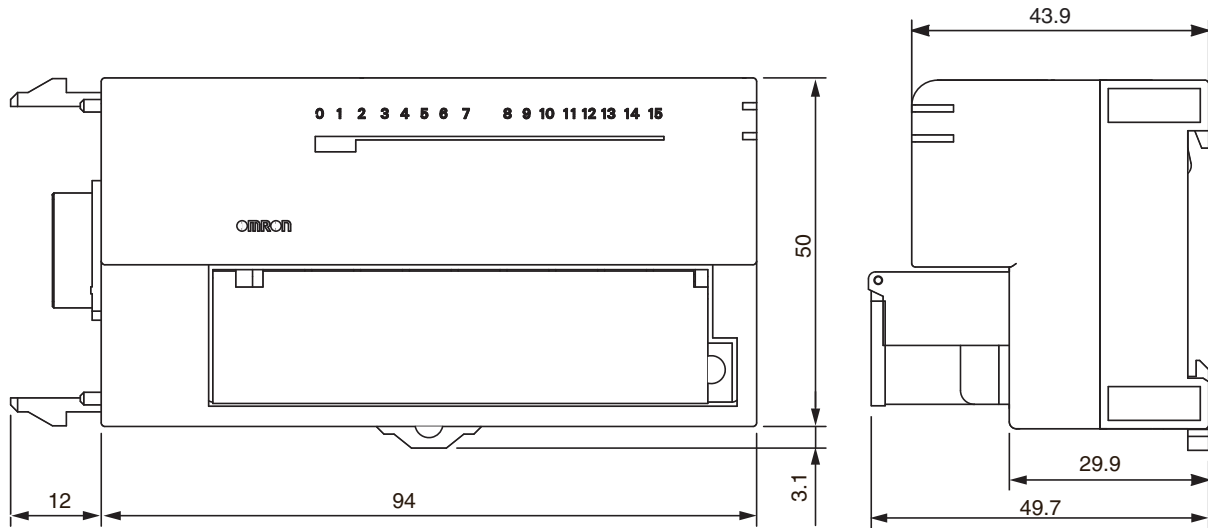

**5-5-13 Transistor Remote Input Terminals with 16 Points and 3-tier I/O Terminal Blocks: DRT2-ID16TA (NPN) and DRT2-ID16TA-1 (PNP)**

**Input Specifications**

Item	Specification	
Model	DRT2-ID16TA	DRT2-ID16TA-1
Internal I/O common	NPN	PNP
Input points	16 points	
ON voltage	15 V DC min. (between each input terminal and V)	15 V DC min. (between each input terminal and G)
OFF voltage	5 V DC max. (between each input terminal and V)	5 V DC max. (between each input terminal and G)
OFF current	1.0 mA max.	
Input current	6.0 mA max./point at 24 V DC 3.0 mA min./point at 17 V DC	
ON delay time	1.5 ms max.	
OFF delay time	1.5 ms max.	
Number of circuits	8 points with two commons	

**Components of the DRT2-ID16TA and DRT2-ID16TA-1**

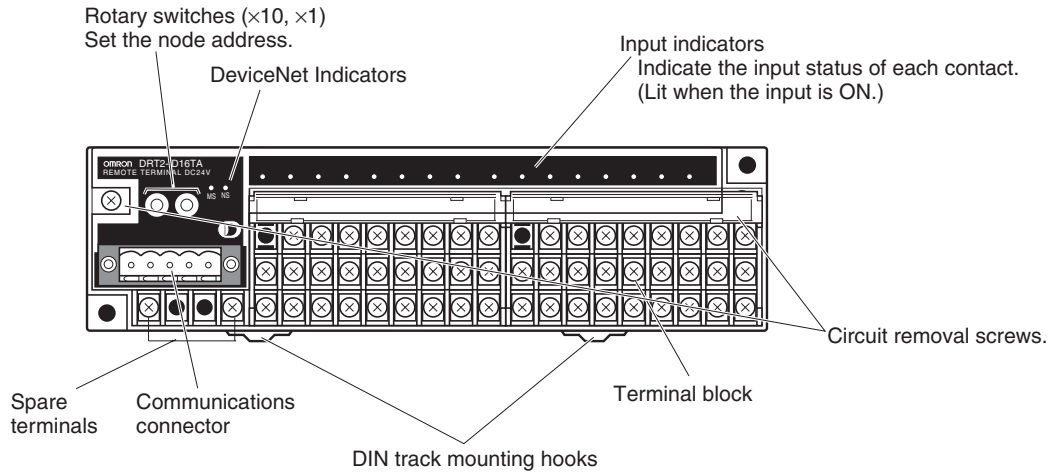

**Internal Circuits**

**DRT2-ID16TA (NPN)**

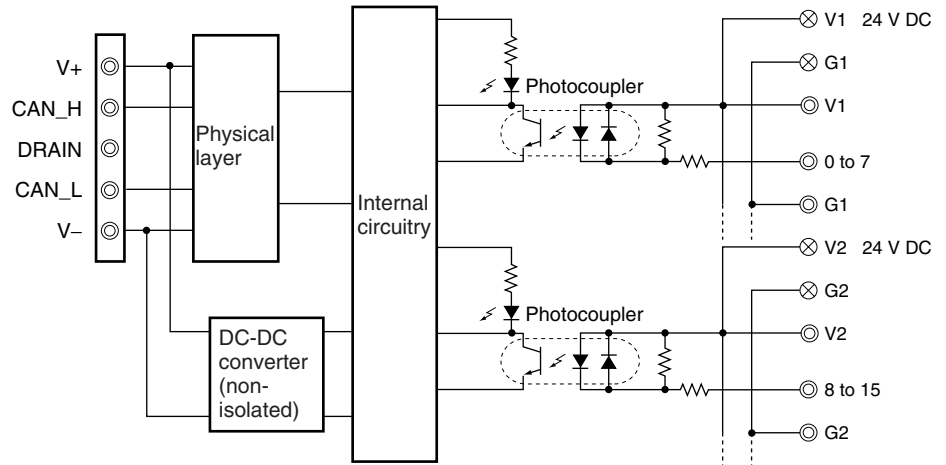

**DRT2-ID16TA-1 (PNP)**

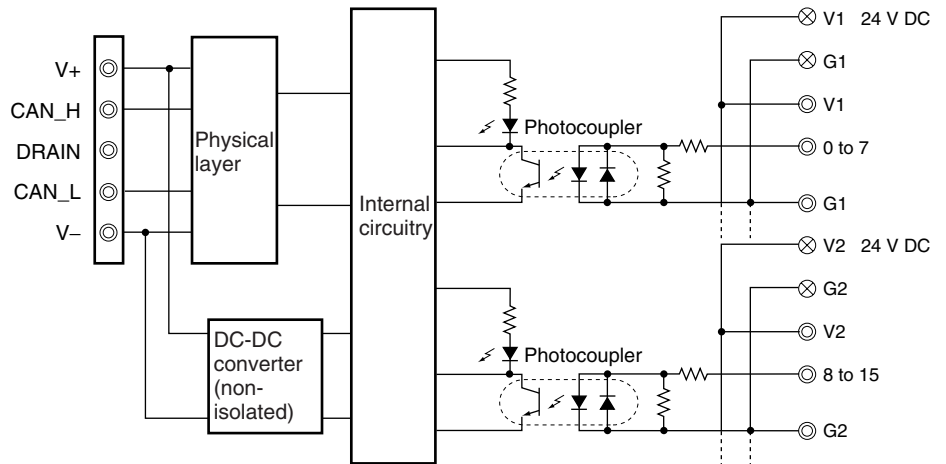

**Wiring**

**DRT2-ID16TA (NPN)**

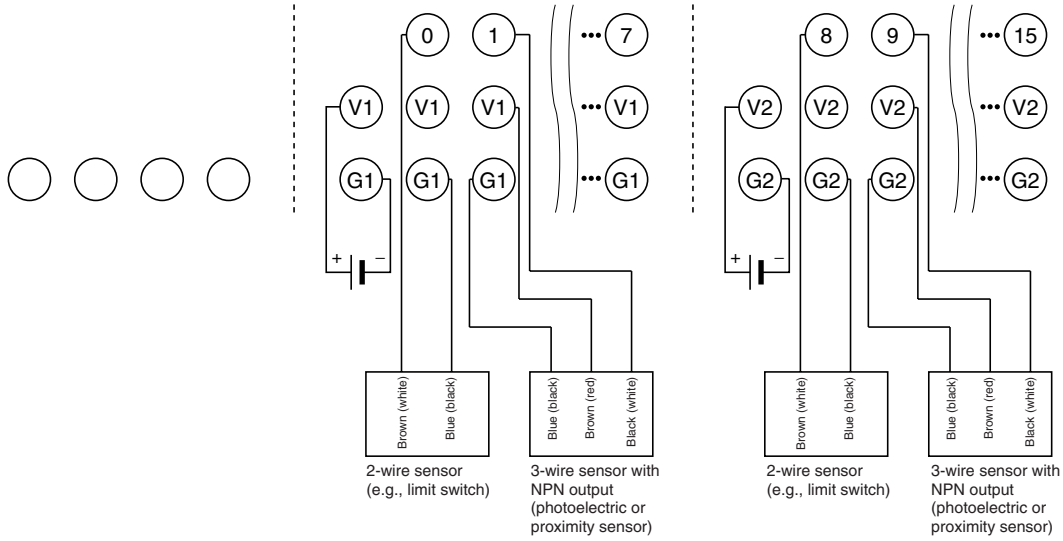

**DRT2-ID16TA-1 (PNP)**

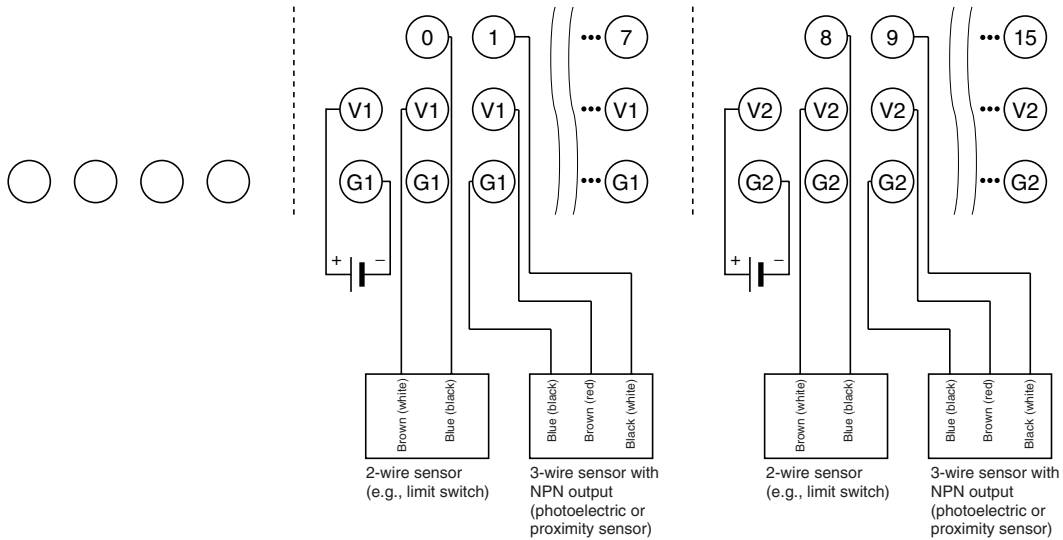

- Note**
1. V1 is not connected internally to V2, and G1 is not connected internally to G2. Connect them carefully. Do not connect anything to the reserved terminals.
  2. Wire colors have been changed according to revisions in the JIS standards for photoelectric and proximity sensors. The colors in parentheses are the wire colors prior to the revisions.

**Dimensions: DRT2-ID16TA and DRT2-ID16TA-1**

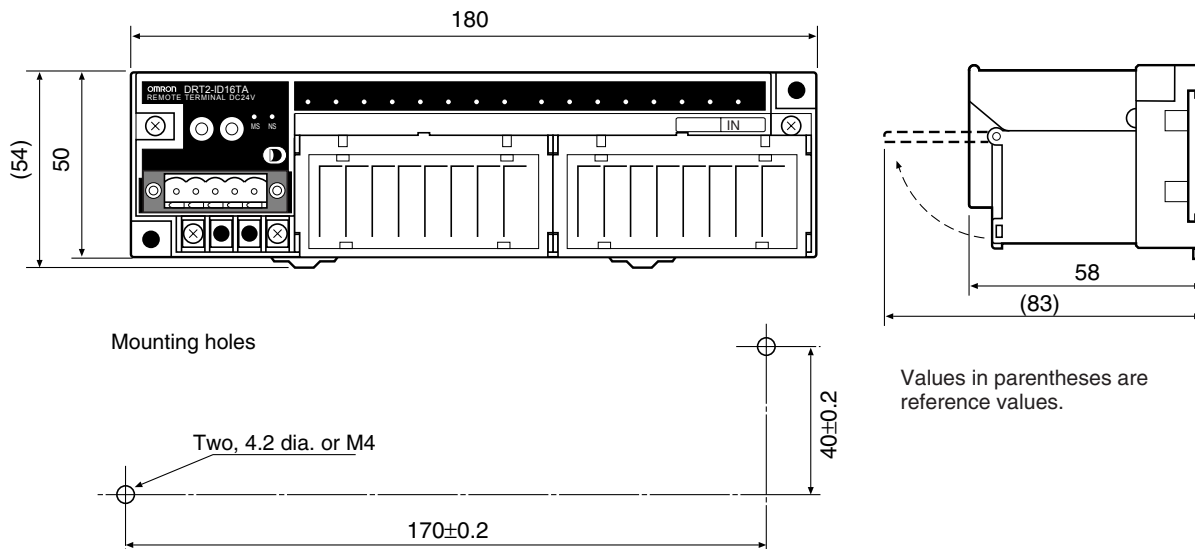

**Note** The circuit section can be removed by loosening the circuit removal screws. (Refer to *Components of the DRT2-ID16TA and DRT2-ID16TA-1.*) Always turn OFF the communications, internal, and I/O power supplies before removing or attaching the circuit section.

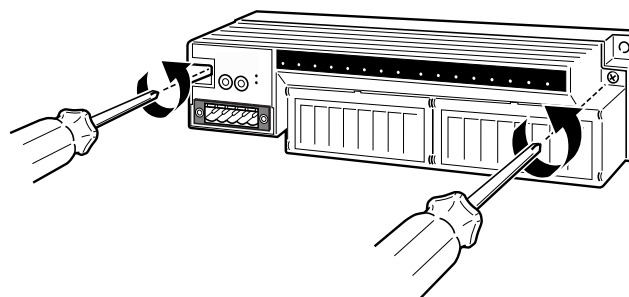

**5-5-14 Transistor Remote Output Terminals with 16 Points and 3-tier I/O Terminal Blocks: DRT2-OD16TA (NPN) and DRT2-OD16TA-1 (PNP)**

**Output Specifications**

Item	Specification	
Model	DRT2-OD16TA	DRT2-OD16TA-1
Internal I/O common	NPN	PNP
Output points	16 points	
Rated output current	0.5 A/point	
Residual voltage	1.2 V max. (at 0.5 A, between each output terminal and G)	1.2 V max. (at 0.5 A, between each output terminal and V)
Leakage current	0.1 mA max.	
ON delay time	0.5 ms max.	
OFF delay time	1.5 ms max.	
Number of circuits	8 points	



**Components of the DRT2-OD16TA and DRT2-OD16TA-1**

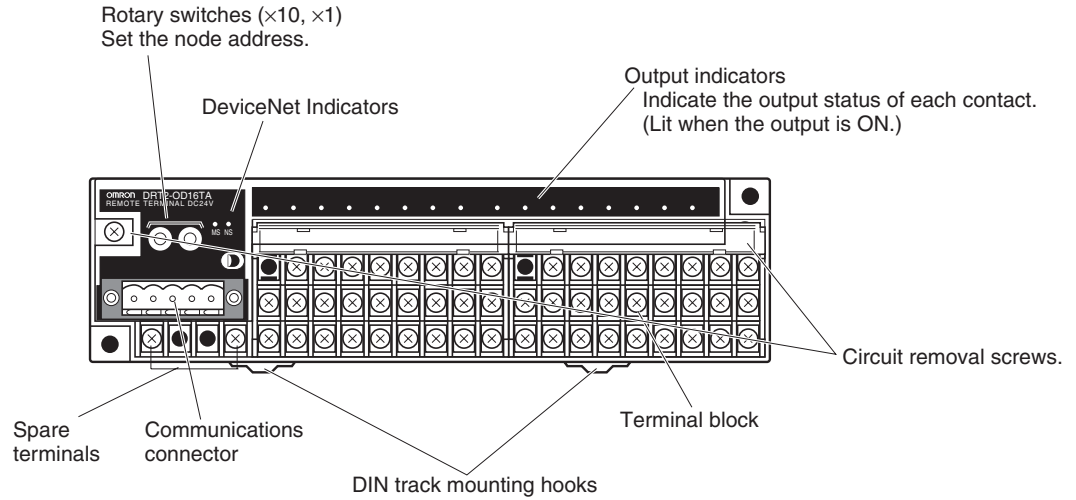

**Internal Circuits**

**DRT2-OD16TA (NPN)**

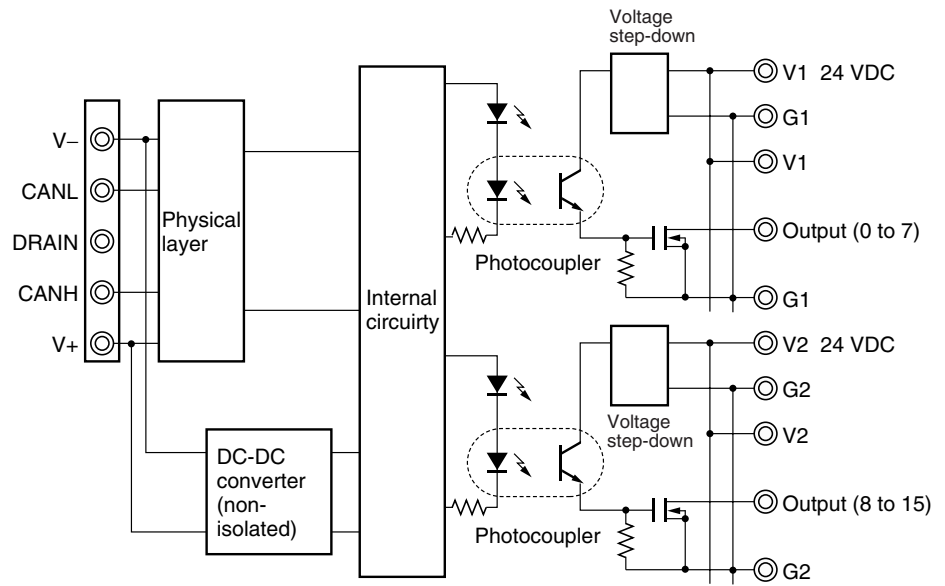

DRT2-OD16TA-1 (PNP)

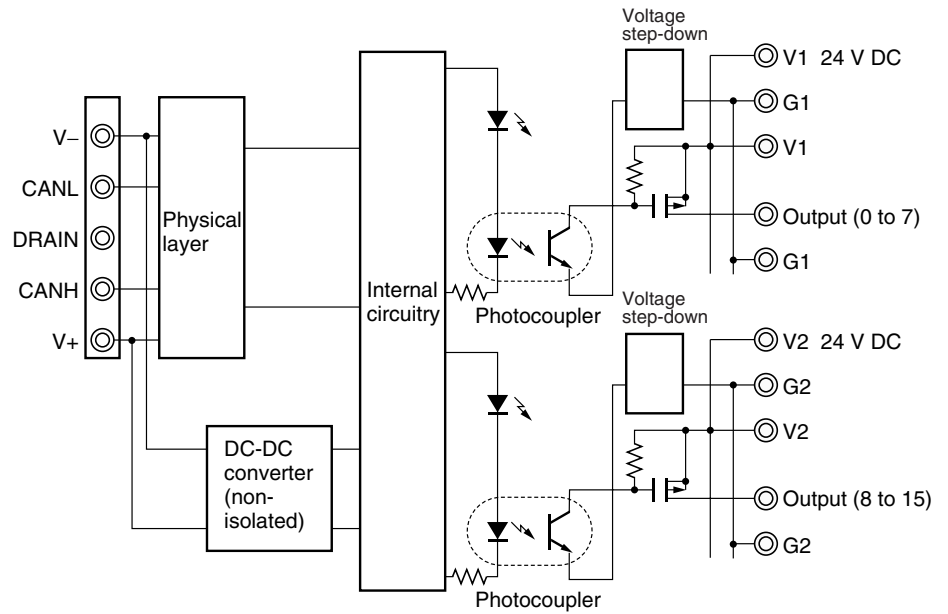

**Wiring**

DRT2-OD16TA (NPN)

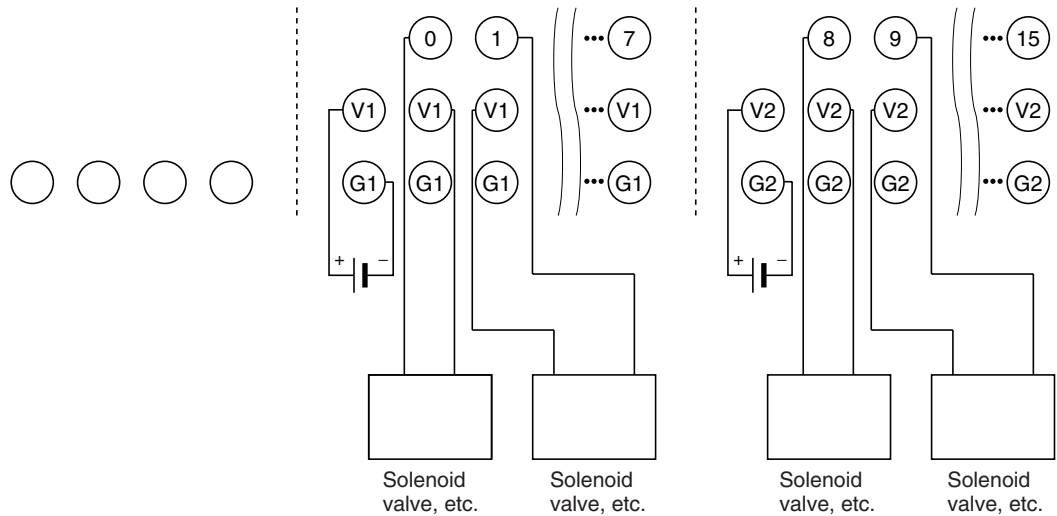

DRT2-OD16TA-1 (PNP)

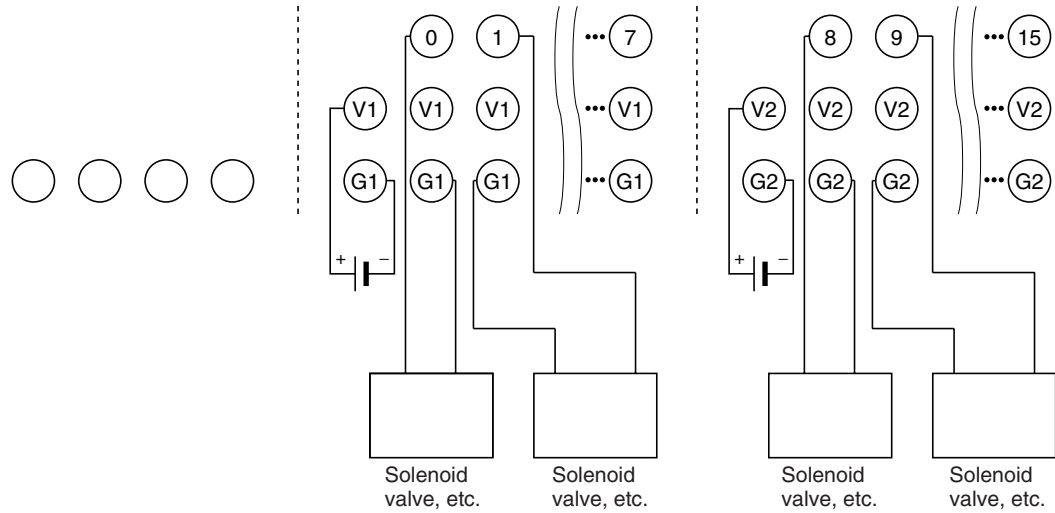

- Note**
1. V1 is not connected internally to V2, and G1 is not connected internally to G2. Connect them carefully.
  2. When using inductive loads (such as solenoid valves), use a load with a built-in diode to absorb reverse power or attach a diode externally.
  3. Do not connect anything to the reserved terminals.

**Dimensions: DRT2-OD16TA and DRT2-OD16TA-1**

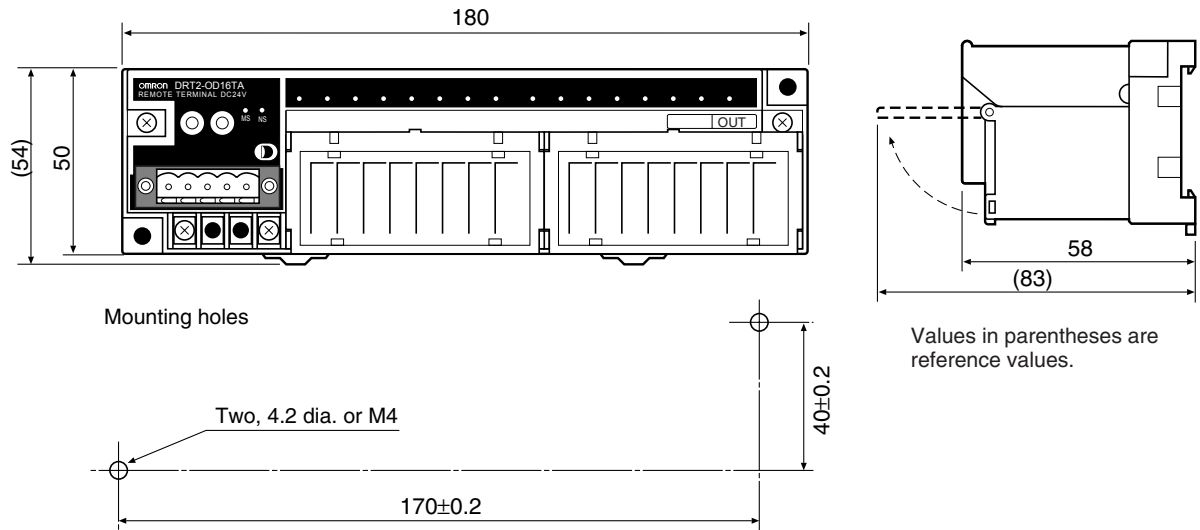

- Note** The circuit section can be removed by loosening the circuit removal screws. (Refer to *Components of the DRT2-OD16TA and DRT2-OD16TA-1.*)

Always turn OFF the communications, internal, and I/O power supplies before removing or attaching the circuit section.

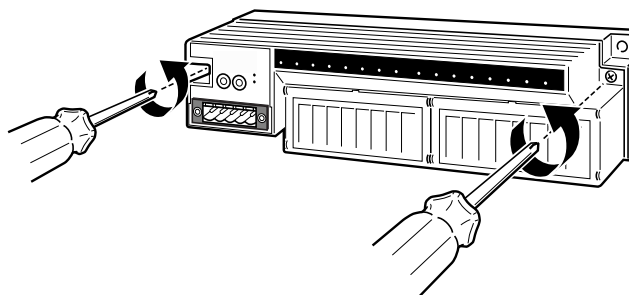

**5-5-15 Transistor Remote I/O Terminals with 8 Inputs and 8 Outputs and 3-tier I/O Terminal Blocks: DRT2-MD16TA (NPN) and DRT2-MD16TA-1 (PNP)**

**Input Specifications**

Item	Specification	
	DRT2-MD16TA	DRT2-MD16TA-1
Model	DRT2-MD16TA	DRT2-MD16TA-1
Internal I/O common	NPN	PNP
Input points	8 points	
ON voltage	15 V DC min. (between each input terminal and V)	15 V DC min. (between each input terminal and G)
OFF voltage	5 V DC max. (between each input terminal and V)	5 V DC max. (between each input terminal and G)
OFF current	1.0 mA max.	
Input current	6.0 mA max./point at 24 V DC 3.0 mA min./point at 17 V DC	
ON delay time	1.5 ms max.	
OFF delay time	1.5 ms max.	
Number of circuits	8 points with one common	

**Output Specifications**

Item	Specification	
	DRT2-MD16TA	DRT2-MD16TA-1
Model	DRT2-MD16TA	DRT2-MD16TA-1
Internal I/O common	NPN	PNP
Output points	8 points	
Rated output current	0.5 A/point	
Residual voltage	1.2 V max. (at 0.5 A, between each output terminal and G)	1.2 V max. (at 0.5 A, between each output terminal and V)
Leakage current	0.1 mA max.	
ON delay time	0.5 ms max.	
OFF delay time	1.5 ms max.	
Number of circuits	8 points with one common	

**Components of the DRT2-MD16TA and DRT2-MD16TA-1**

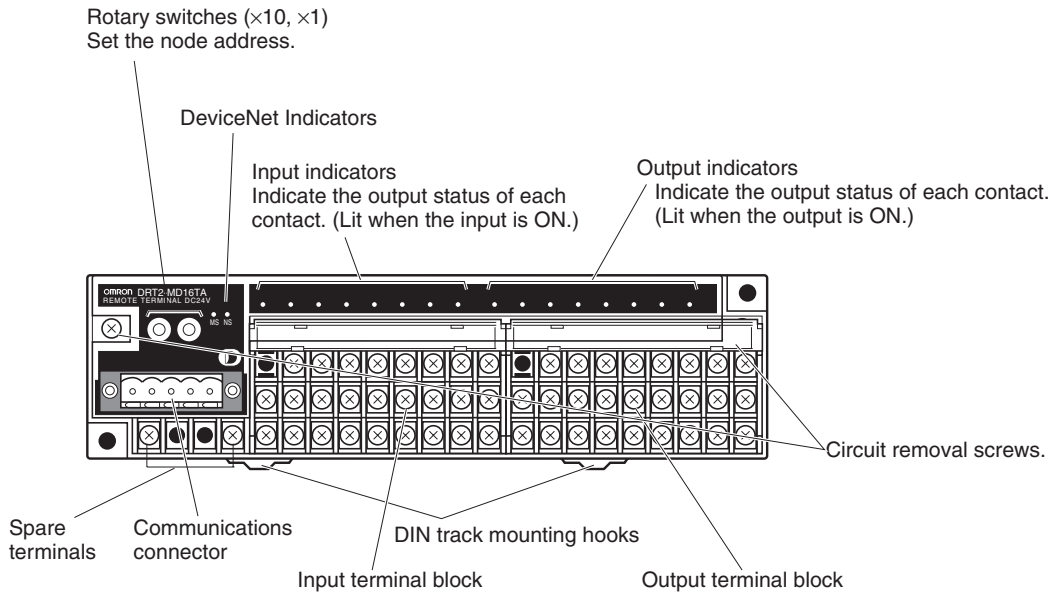

**Internal Circuits**

**DRT2-MD16TA (NPN)**

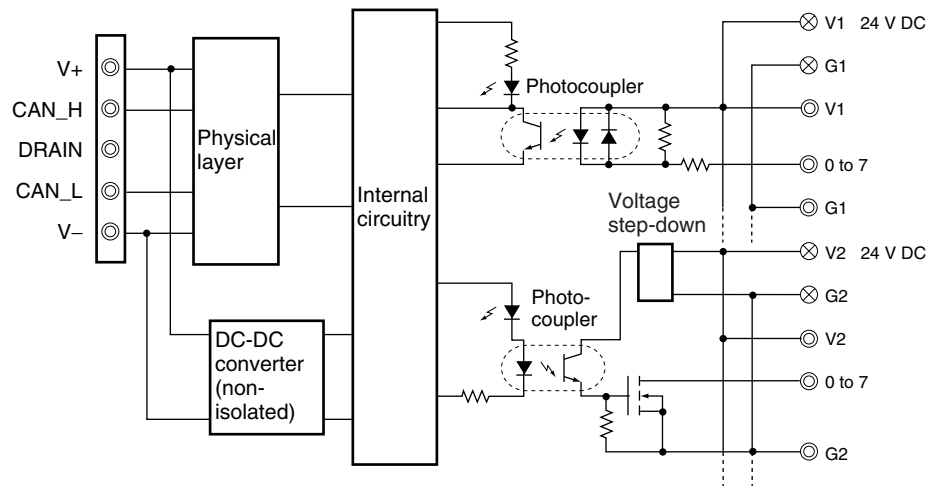

**DRT2-MD16TA-1 (PNP)**

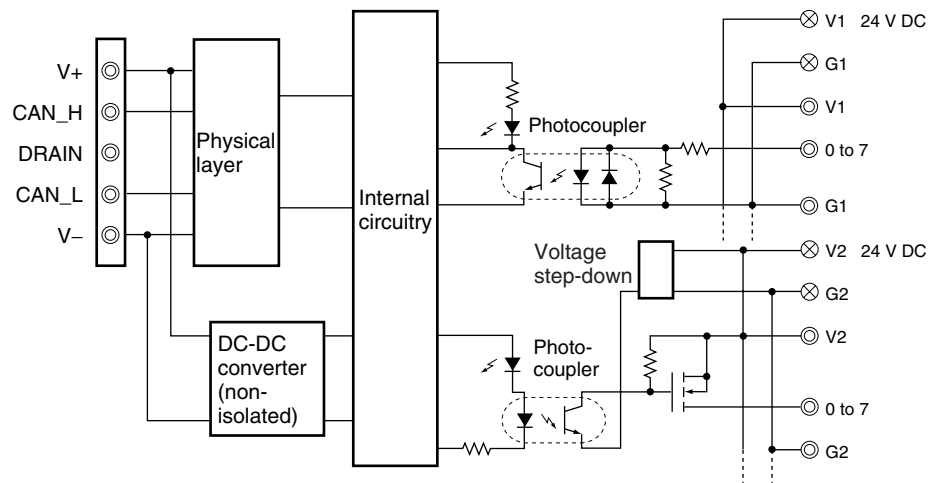

**Wiring**

**DRT2-MD16TA (NPN)**

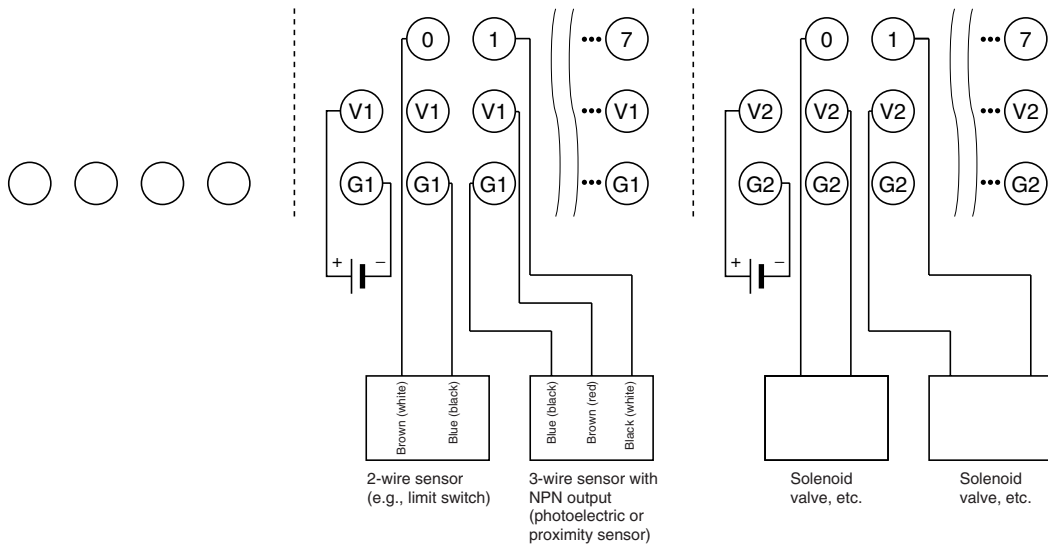

**DRT2-MD16TA-1 (PNP)**

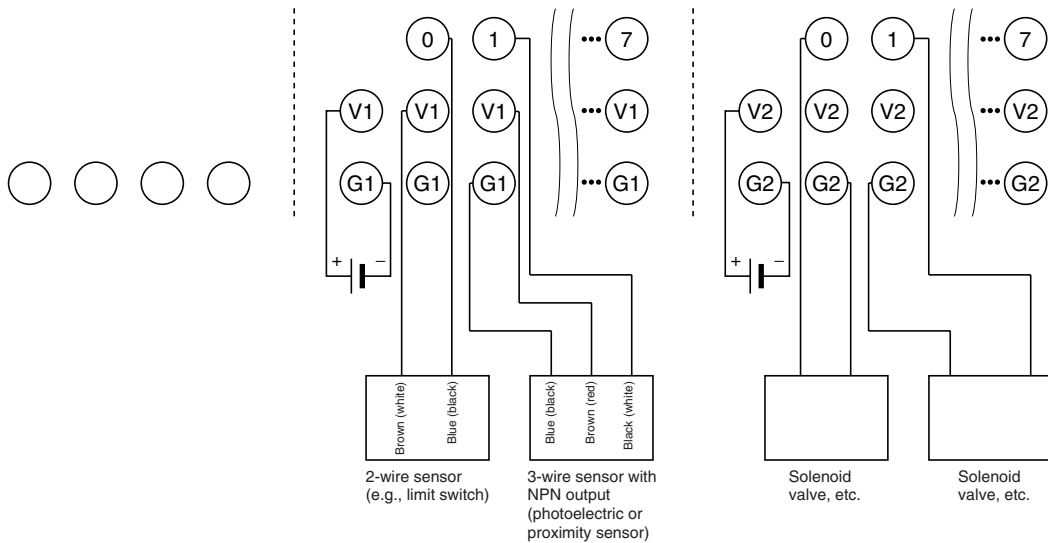

- Note**
1. V1 is not connected internally to V2, and G1 is not connected internally to G2. Connect them carefully
  2. When using inductive loads (such as solenoid valves), use a load with a built-in diode to absorb reverse power or attach a diode externally.
  3. Do not connect anything to the reserved terminals.
  4. Wire colors have been changed according to revisions in the JIS standards for photoelectric and proximity sensors. The colors in parentheses are the wire colors prior to the revisions.

**Dimensions: DRT2-MD16TA and DRT2-MD16TA-1**

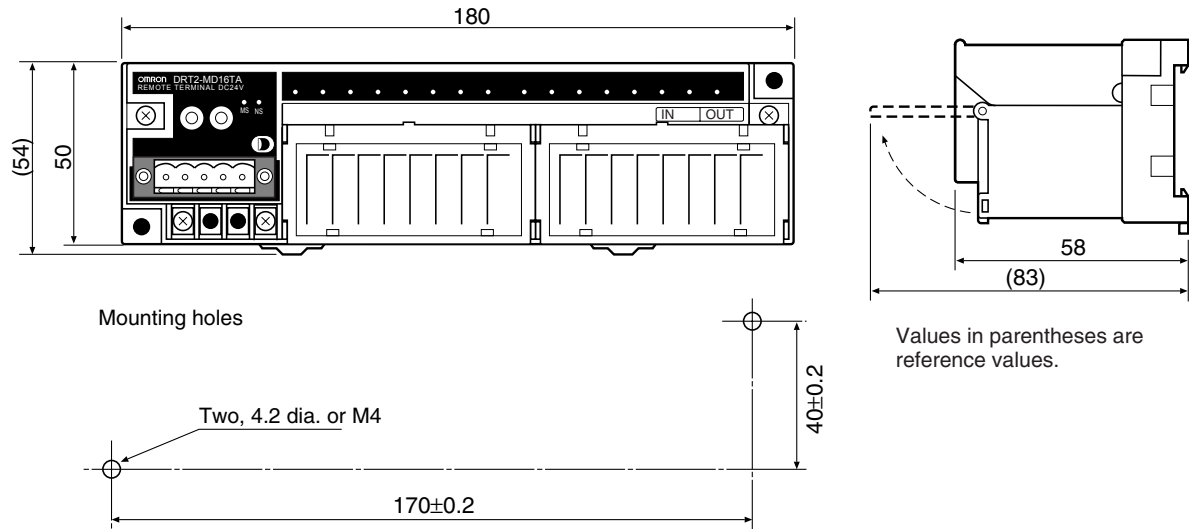

**Note** The circuit section can be removed by loosening the circuit removal screws. (Refer to *Components of the DRT2-MD16TA and DRT2-MD16TA-1.*) Always turn OFF the communications, internal, and I/O power supplies before removing or attaching the circuit section.

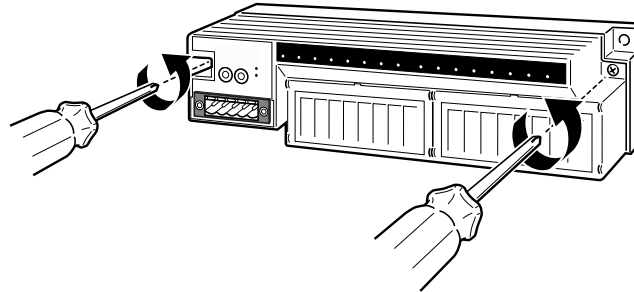

**5-5-16 Mounting in Control Panels**

A Remote I/O Terminal (Basic Unit or Expansion Unit) can be mounted in a control panel using either of the following methods.

**Using DIN Track**

Mount the back of the Remote I/O Terminal to a 35-mm DIN Track. To mount the Terminal, pull down on the mounting hook on the back of the Terminal with a screwdriver, latch the DIN Track onto the back of the Terminal, and then secure the Terminal to the DIN Track. Secure all Slaves on both ends of the DIN Track with End Plates.

**Connecting End Plates**

Hook the bottom of the End Plate onto the DIN Track, as shown at (1) in the following diagram, then hook the top of the End Plate as shown at (2).

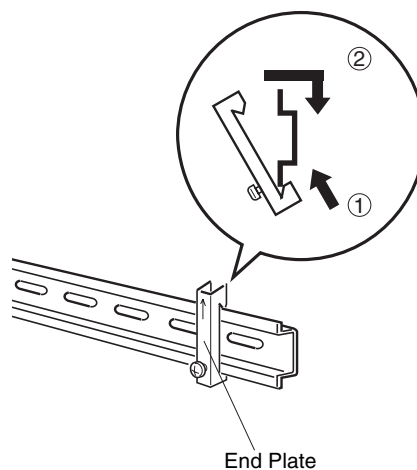

**Note** Always attach an End Plate to both ends of Slaves connected to the DIN Track.

**Mounting Direction**

Unless specific restrictions are given for the Slave, it can be mounted in any of the following six directions.

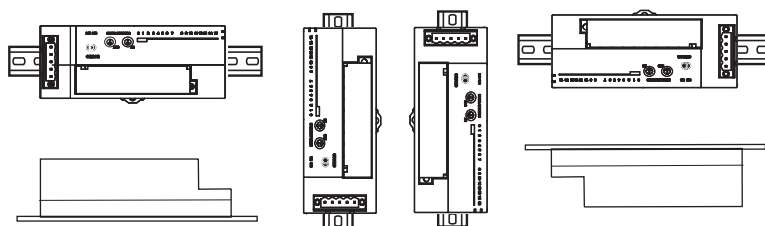

**5-5-17 Wiring the I/O Power Supply and I/O Lines**

The I/O power supplies and I/O lines are all wired to M3 screw terminals. Connect M3 crimp terminals to the cables and then connect them to the Terminal Block.

Tighten the screws to a torque of 0.5 N·m.

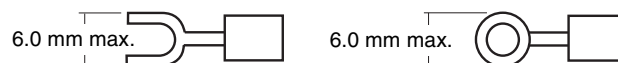

**Wiring the I/O Power Supply**

Refer to the wiring details for Slave for information on the terminal arrangement at the terminal block.

Connect an I/O power supply to the Expansion Unit if required. (Refer to 5-5-2 *Increasing I/O Using an Expansion Unit.*)



**Example:**

I/O power supply for a DRT2-ID16 Remote I/O Terminal.

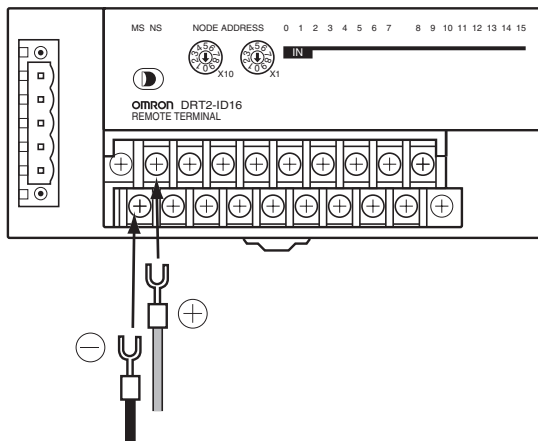

**Wiring I/O**

Refer to the wiring details for the Slave for information on the terminal arrangement at the terminal block and external I/O wiring.

**Example:**

Wiring to input 0 on a DRT2-ID16 Remote I/O Terminal.

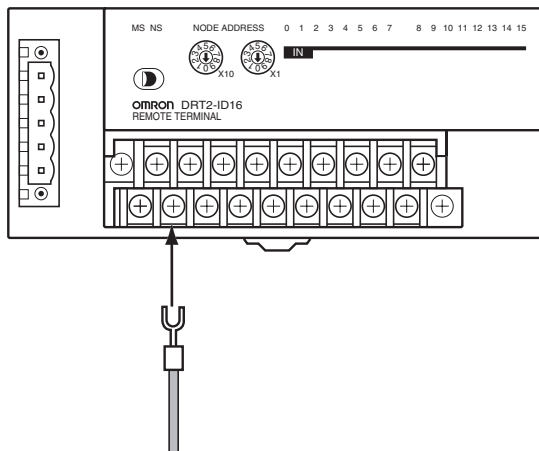

**5-6 Connector Terminals with Transistors**

**5-6-1 Node Address, Baud Rate, and Output Hold/Clear Settings**

These parameters are set in the same way as for Remote I/O Terminals with Transistors. Refer to 5-5-1 Node Address, Baud Rate, and Output Hold/Clear Settings.

### 5-6-2 Industry Standard Sensor Connector Assembly, Wiring, and Installation

The DRT2-□D16S(-1) Sensor Connector Terminal uses an industry standard sensor connector. When connecting the sensor or external device to the Connector Terminal, a special connector must be attached to the sensor or external device cable.

OMRON XN2A-1430  
Cable Connector

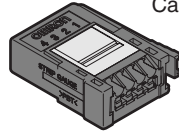

Use the following procedure to attach the Cable Connector to the sensor or external device cable.

1,2,3...

1. Checking the Cable Connector and Cable Wire Size

The applicable Cable Connector depends on the manufacturer and the wire size. Use the following table to check that the Cable Connector and sensor or external device cable wire size are compatible.

**Tyco Electronics Corporation**

Model	Housing color	Applicable wire range	
3-1473562-4	Orange	Sheath outer diameter: 0.6 to 0.9 mm dia.	Cross section: 0.08 to 0.5 mm <sup>2</sup>
1-1473562-4	Red	Sheath outer diameter: 0.9 to 1.0 mm dia.	
1473562-4	Yellow	Sheath outer diameter: 1.0 to 1.15 mm dia.	
2-1473562-4	Blue	Sheath outer diameter: 1.15 to 1.35 mm dia.	
4-1473562-4	Green	Sheath outer diameter: 1.35 to 1.60 mm dia.	

**Sumitomo 3M**

Model	Housing color	Applicable wire range
37104-3101-000FL	Red	AWG26 (0.14 mm <sup>2</sup> ) to AWG24 (0.2 mm <sup>2</sup> ), sheath outer diameter: 0.8 to 1.0 mm
37104-3122-000FL	Yellow	AWG26 (0.14 mm <sup>2</sup> ) to AWG24 (0.2 mm <sup>2</sup> ), sheath outer diameter: 1.0 to 1.2 mm
37104-3163-000FL	Orange	AWG26 (0.14 mm <sup>2</sup> ) to AWG24 (0.2 mm <sup>2</sup> ), sheath outer diameter: 1.2 to 1.6 mm
37104-2124-000FL	Green	AWG22 (0.3 mm <sup>2</sup> ) to AWG20 (0.5 mm <sup>2</sup> ), sheath outer diameter: 1.0 to 1.2 mm
37104-2165-000FL	Blue	AWG22 (0.3 mm <sup>2</sup> ) to AWG20 (0.5 mm <sup>2</sup> ), sheath outer diameter: 1.2 to 1.6 mm
37104-2206-000FL	Gray	AWG22 (0.3 mm <sup>2</sup> ) to AWG20 (0.5 mm <sup>2</sup> ), sheath outer diameter: 1.6 to 2.0 mm

**OMRON**

Model	Specifications	Applicable wire range
XN2A-1430	Spring clamp type	AWG28 (0.08 mm <sup>2</sup> ) to AWG20 (0.5 mm <sup>2</sup> ), sheath outer diameter: 1.5 mm max.

2. Preparing the Sensor or External Device Cables

**Using Tyco Electronics Amp or Sumitomo 3M Connectors**

The sensor and external device cables for connector output with transistors are normally either semi-stripped or stripped, as shown in the following diagram.

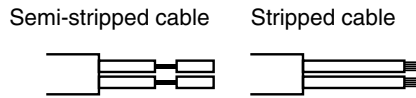

When the cables are prepared this way, a Cable Connector cannot be attached, so first cut the end and remove the cable sheath as shown in the following diagram. (Do not strip the core wires.)



**Using OMRON Connectors**

Align the cable with the strip gauge on the side of the connector. Remove 7 to 8 mm of the wiring sheath, and twist the exposed wires several times.

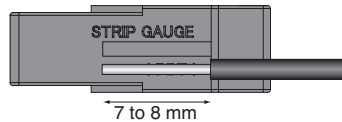

3. Inserting the Wire into the Cable Connector (Hard Wiring Procedure)

**Using Tyco Electronics Amp or Sumitomo 3M Connectors**

1,2,3...

1. Insert the wire into the cover of the Cable Connector. Check that the terminal number and wire color match, and insert all the way to the back of the connector.
2. Join the cover and plug connector, using pliers or another tool to push in fully. At the same time, push in the middle of the cover straight so that it is not crooked.

**Using OMRON Connectors**

1,2,3...

1. Use a flat-blade screwdriver to push the operation lever inside the connector's operation opening until it locks, as shown in the following diagram.

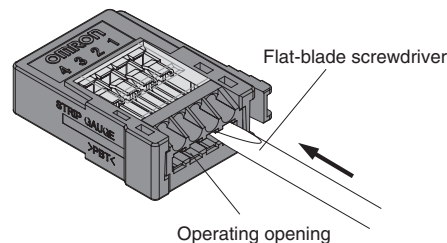

2. Insert the line all the way to the back of the wire insertion opening. Check that the sheath of the line is inserted into the wire insertion opening, and that the end of the conductor has passed through the connection part.

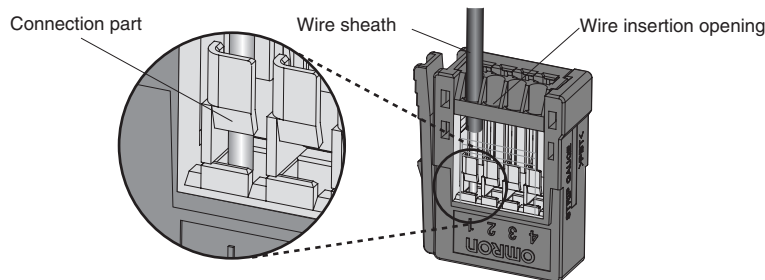

3. Insert a flat-blade screwdriver into the reset opening and pull back the lever lightly. A click sound will be heard and the operation lever will return to its normal position.

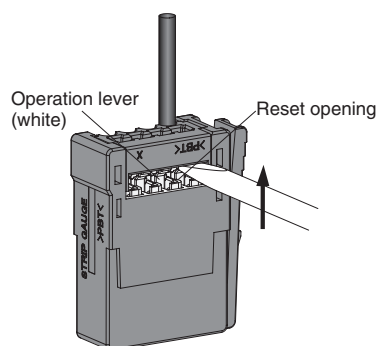

4. Check that the operation lever has returned to its position. Lightly pull on the lines, and if there is any resistance, they are connected properly.

**Note** When connecting the sensor, insert the wire so that the terminal number on the cover matches the sensor wire color, as shown in the following table.

Terminal number	Using DRT2-ID16S		Using DRT2-ID16S-1	
	3-wire sensor (without self-diagnostic output function)	2-wire sensor (without self-diagnostic output function)	3-wire sensor (without self-diagnostic output function)	2-wire sensor (without self-diagnostic output function)
1	Brown (red)	---	Brown (red)	Brown (white)
2	---	---	---	---
3	Blue (black)	Blue (black)	Blue (black)	---
4	Black (white)	Brown (white)	Black (white)	Blue (black)

**Note** Wire colors have been changed according to revisions in the JIS standards for photoelectric and proximity sensors. The colors in parentheses are the wire colors prior to the revisions.

**Note** To remove a wire, push in the operation lever, check that the operation lever has locked, and then pull out the wire. After removing the wire, always return the operation lever to its normal position.

### 5-6-3 Connector Terminals with 16 Transistor Inputs: DRT2-ID16S (NPN) and DRT2-ID16S-1 (PNP)

#### Input Specifications

Item	Specifications	
Model	DRT2-ID16S	DRT2-ID16S-1
Internal I/O common	NPN	PNP
Input points	16 points	
ON voltage	9 V DC min. (between each input terminal and V)	9 V DC min. (between each input terminal and G)
OFF voltage	5 V DC max. (between each input terminal and V)	5 V DC max. (between each input terminal and G)
OFF current	1 mA max.	
Input current	11 mA max./point (for 24 V DC) 3.0 mA max./point (for 11 V DC)	11 mA max./point (for 24 V DC) 3.0 mA max./point (for 11 V DC)
ON delay time	1.5 ms max.	
OFF delay time	1.5 ms max.	
Number of circuits	16 points with one common	
Sensor short-circuit detection current	100 mA min. (per two inputs)	

#### Component Names and Functions: DRT2-ID16S and DRT2-ID16S-1

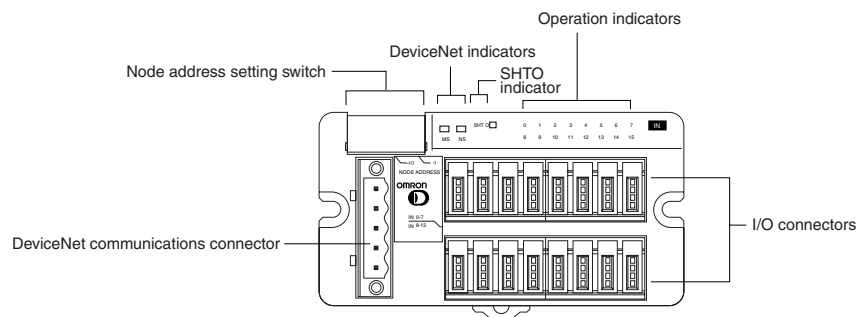

#### Indicator Meanings

Indicator name	Color	Status	Meaning
SHTO	Red	Lit	The sensor power supply has short-circuited.

#### Internal Circuits

##### DRT2-ID16S (NPN)

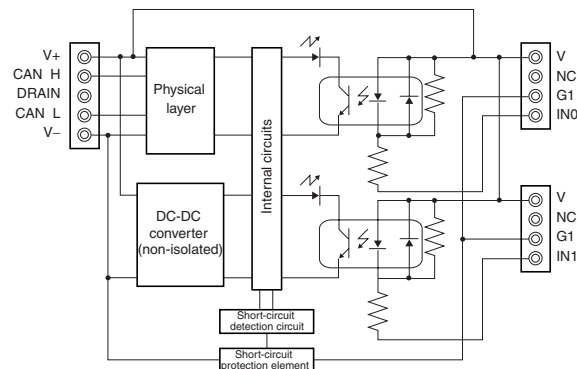

DRT2-ID16S-1 (PNP)

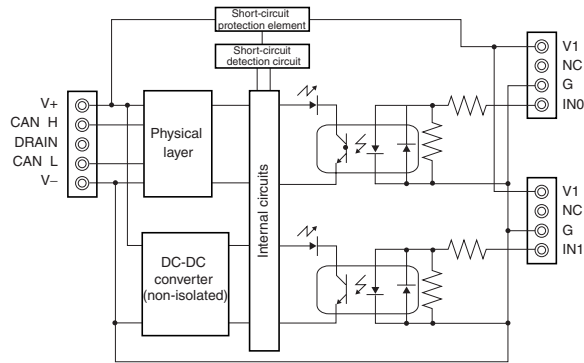

Wiring

DRT2-ID16S (NPN)

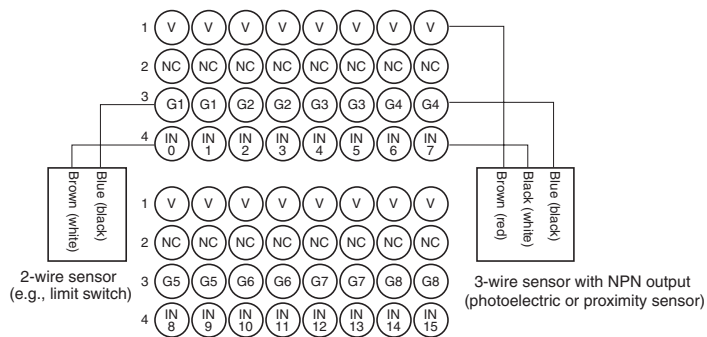

DRT2-ID16S-1 (PNP)

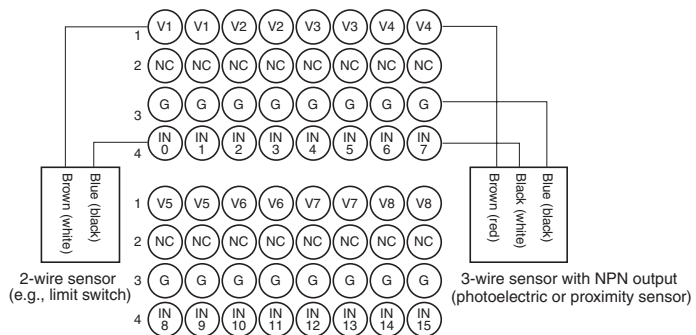

**Note** Wire colors in parentheses are the previous JIS colors for photoelectric and proximity sensors.

Dimensions (DRT2-ID16S and DRT2-ID16S-1)

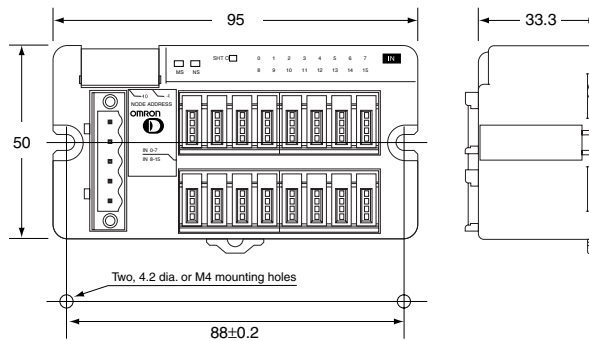

### 5-6-4 Connector Terminals (Sensor Connector Type with 8 Inputs and 8 Outputs): DRT2-MD16S (NPN) and DRT2-MD16S-1 (PNP)

#### Input Specifications

Item	Specification	
	DRT2-MD16S	DRT2-MD16S-1
Model	DRT2-MD16S	DRT2-MD16S-1
Internal I/O common	NPN	PNP
Input points	8 points (0 to 7)	
ON voltage	9 V DC min. (between each input terminal and V)	9 V DC min. (between each input terminal and G)
OFF voltage	5 V DC max. (between each input terminal and V)	5 V DC max. (between each input terminal and G)
OFF current	1 mA max.	
Input current	11 mA max./point at 24 V DC 3.0 mA min./point at 11 V DC	
ON delay time	1.5 ms max.	
OFF delay time	1.5 ms max.	
Number of circuits	8 points with one common	
Sensor short-circuit detection current	100 mA min. (per two inputs)	

#### Output Specifications

Item	Specification	
	DRT2-MD16S	DRT2-MD16S-1
Model	DRT2-MD16S	DRT2-MD16S-1
Internal I/O common	NPN	PNP
Output points	8 points (0 to 7)	
Rated output current	0.3 A/point, 2.4 A/common	0.3 A/point, 1.6 A/common
Residual voltage	1.2 V max. (at 0.3 A, between each output terminal and G)	1.2 V max. (at 0.3 A, between each output terminal and V)
Leakage current	0.1 mA max.	
ON delay time	1.5 ms max.	
OFF delay time	1.5 ms max.	
Number of circuits	8 points with one common	
External load short-circuit detection current	2.4 A min. per common	1.6 A min. per common

#### Components of the DRT2-MD16S and DRT2-MD16S-1

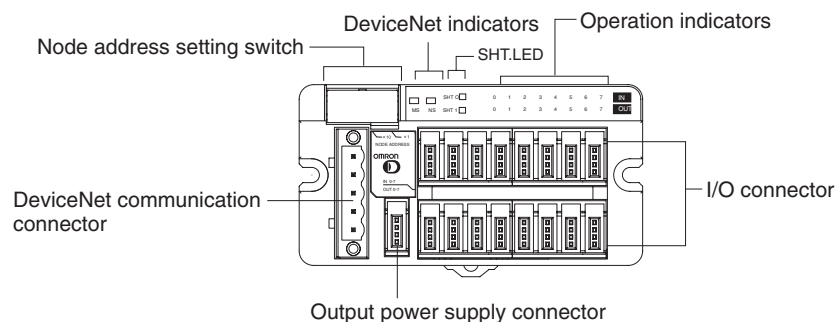

Indicator Meanings

Indicator name	Color	Status	Meaning
SHT0	Red	Lit	Sensor power short-circuit
SHT1	Red	Lit	External load short-circuit

Internal Circuits

DRT2-MD16S (NPN)

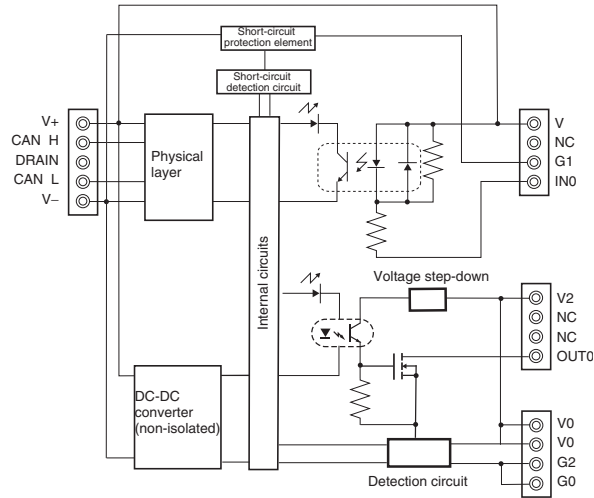

DRT2-MD16S-1 (NPN)

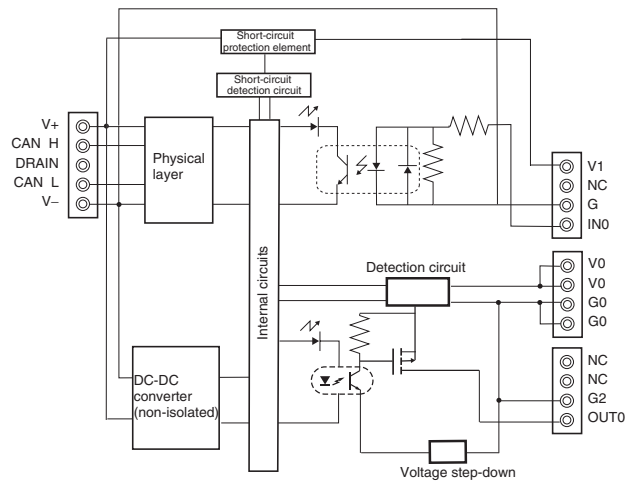



**Wiring**

**DRT2-MD16S (NPN)**

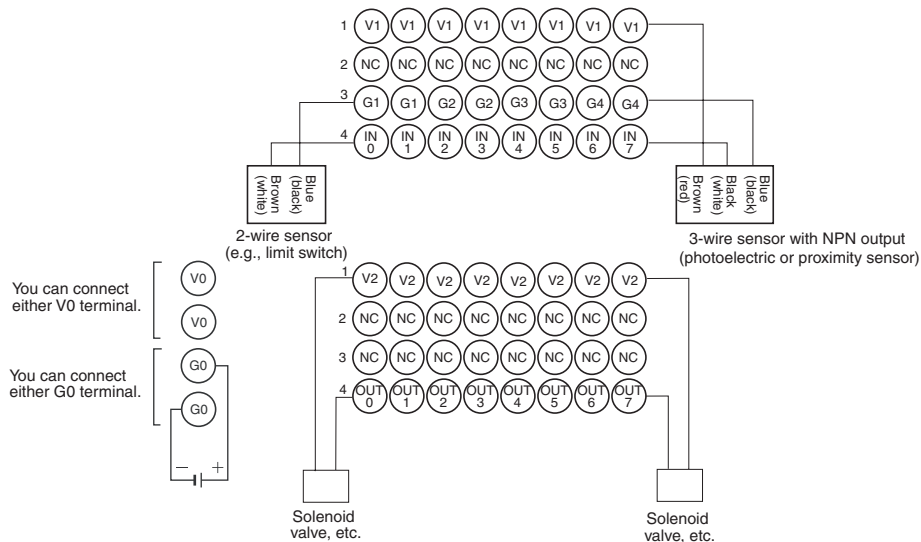

**DRT2-MD16S-1 (PNP)**

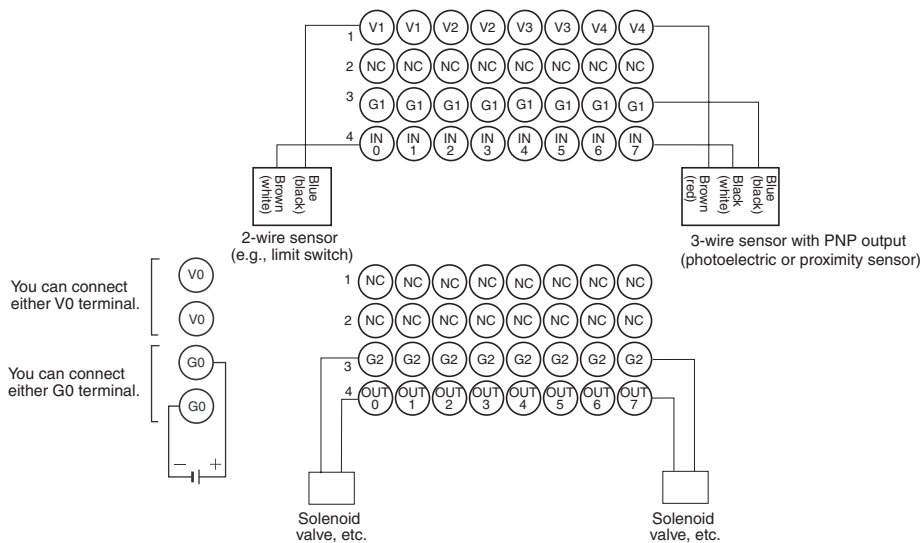

- Note**
1. There are two V0 terminals and two G0 terminals for I/O power supply terminals in the output section. Use one pair of these terminals for the I/O power supply for this Unit and the other pair for the I/O power supply for the next Unit. Do not exceed 3 A for either pair.
  2. Wire colors in parentheses are the previous JIS colors for photoelectric and proximity sensors.

**Dimensions (DRT2-MD16S and DRT2-MD16S-1)**

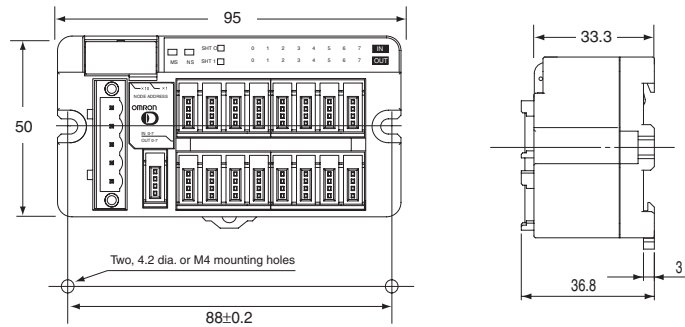

**5-6-5 Transistor Remote Input Terminals with 16 Points and Connectors: DRT2-ID16ML(X) (NPN) and DRT2-ID16ML(X)-1 (PNP)**

**Input Specifications**

Item	Specification	
Model	DRT2-ID16ML(X)	DRT2-ID16ML(X)-1
Internal I/O common	NPN	PNP
Input points	16 points	
ON voltage	17 V DC min. (between each input terminal and V)	17 V DC min. (between each input terminal and G)
OFF voltage	5 V DC max. (between each input terminal and V)	5 V DC max. (between each input terminal and G)
OFF current	1.0 mA max.	
Input current	6.0 mA max./point at 24 V DC 3.0 mA min./point at 17 V DC	
ON delay time	1.5 ms max.	
OFF delay time	1.5 ms max.	
Max. simultaneously ON input points	16 points (See note.)	
Number of circuits	16 points with one common	

**Note** All 16 inputs can be ON simultaneously if the Remote I/O Terminal is mounted facing up, but sufficient space will need to be allowed between Units depending on the ambient temperature. Refer to the *Dimensions* diagram on page 156 for details.

**Components of the DRT2-ID16ML(X) and DRT2-ID16ML(X)-1**

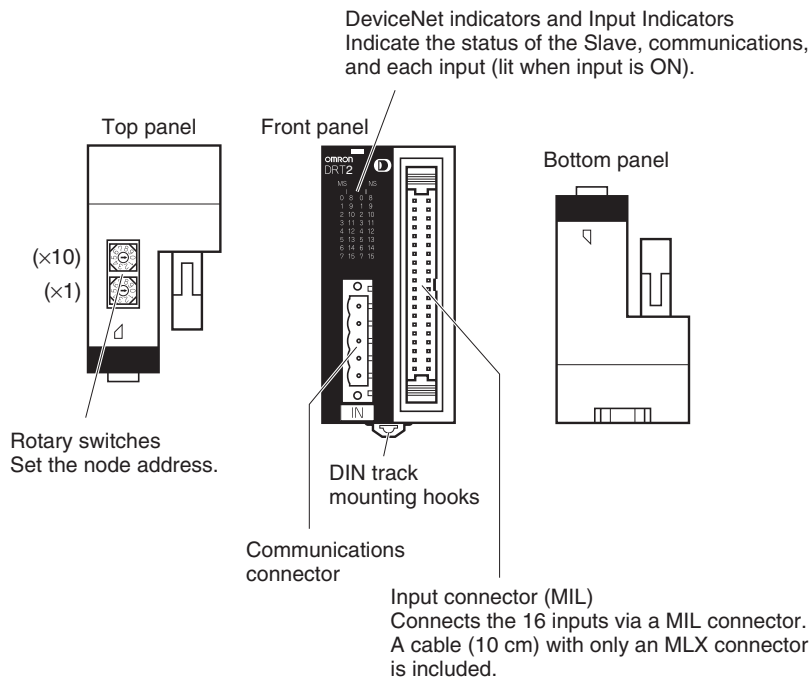

Cable with Connectors (MLX Models Only)

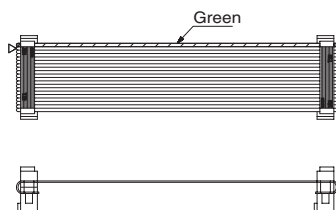

**Input Indicators**

Name	Meaning
0 to 15	Indicate the status of bits (contacts) 0 to 15 in word m. Lit when input is ON; not lit when input is OFF.

**Note** “m” is the first word allocated to the Remote Input Terminal.

**Internal Circuits**

**DRT2-ID16ML(X) (NPN)**

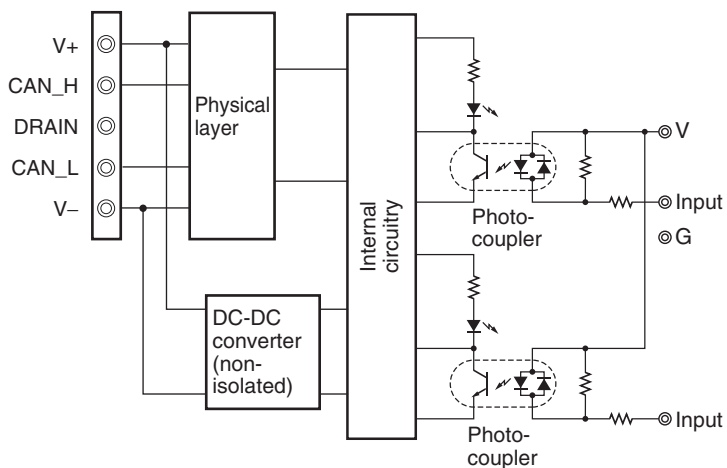

DRT2-ID16ML(X)-1 (PNP)

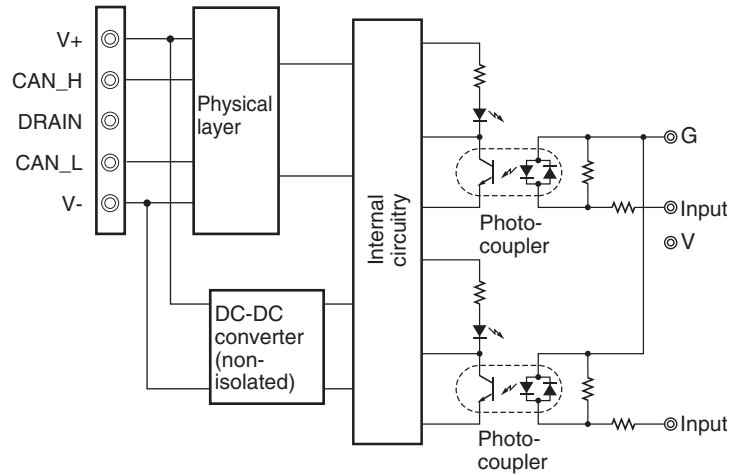

Wiring

DRT2-ID16ML(X) (NPN)

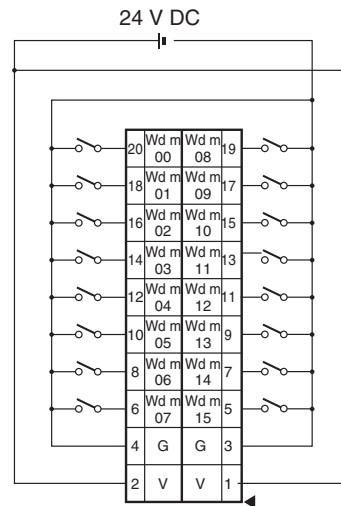

DRT2-ID16ML(X)-1 (PNP)

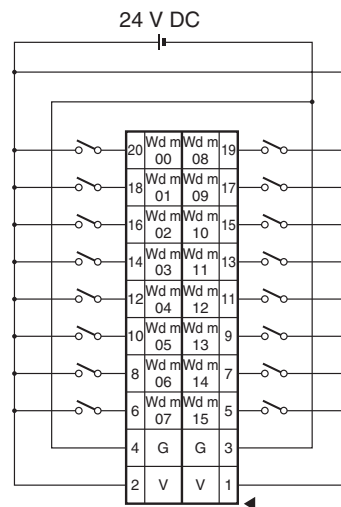

**Note** 1. V terminals are connected internally, as are the G terminals. Connect them carefully.

2. Wire the V terminals and G terminals correctly so that the following functions operate properly.
  - I/O Power Status Monitor
  - Contact Operation Counter
  - Total ON Time Monitor
  - Function preventing malfunction caused by inrush current at startup.

If these functions are not being used, input signals will be received even if the G terminals of the DRT2-ID16ML(X) or V terminals of the DRT2-ID16ML(X)-1 are not connected.

**I/O Allocations**

The first word allocated to the Remote Input Terminal is referred to as “word m.” Given this, the bit and word allocations to MIL connector pin numbers are as shown in the following diagram.

Bit	15	14	13	12	11	10	9	8	7	6	5	4	3	2	1	0
Wd m	5	7	9	11	13	15	17	19	6	8	10	12	14	16	18	20

16 inputs

**Dimensions (DRT2-ID16ML(X) and DRT2-ID16ML(X)-1)**

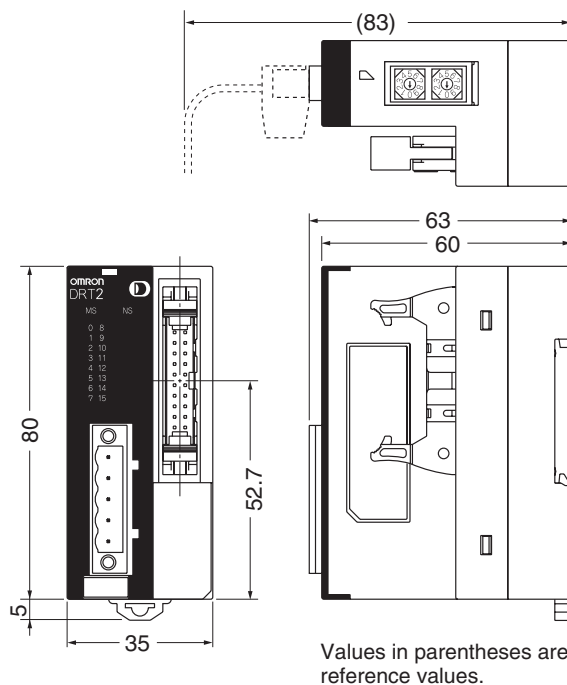

**Note** There are restriction when using the 16-point Transistor Remote Input Terminals with Connectors depending on the ambient operating temperature.

- If the Terminals are not mounted facing up, they can be mounted side-by-side and all inputs can be turned ON simultaneously at 55°C or less.
- If the Terminals are mounted facing up, the distances and temperatures in the graph given below must be maintained to enable turning ON all inputs

simultaneously. For example, at an ambient temperature of 55°C, the Terminals must be separated by at least 10 mm.

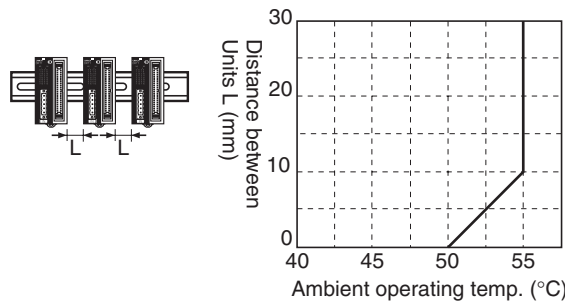

### 5-6-6 Connector Terminals (MIL Connector Type with 16 Outputs): DRT2-OD16ML(X) (NPN) and DRT2-OD16ML(X)-1 (PNP)

#### Output Specifications

Item	Specification	
	Model	DRT2-OD16ML(X)
Internal I/O common	NPN	PNP
Output points	16 points	
Rated output current	0.3 A/point, 2 A/common (See note.)	
Residual voltage	1.2 V max. (at 0.3 A, between each output terminal and G)	1.2 V max. (at 0.3 A, between each output terminal and V)
Leakage current	0.1 mA max.	
ON delay time	0.5 ms max.	
OFF delay time	1.5 ms max.	
Number of circuits	16 points with one common	

**Note** Do not allow the total load current to exceed 2 A and do not allow the load current on either the V or G terminal to exceed 1 A.

**Components of the DRT2-OD16ML(X) and DRT2-OD16ML(X)-1**

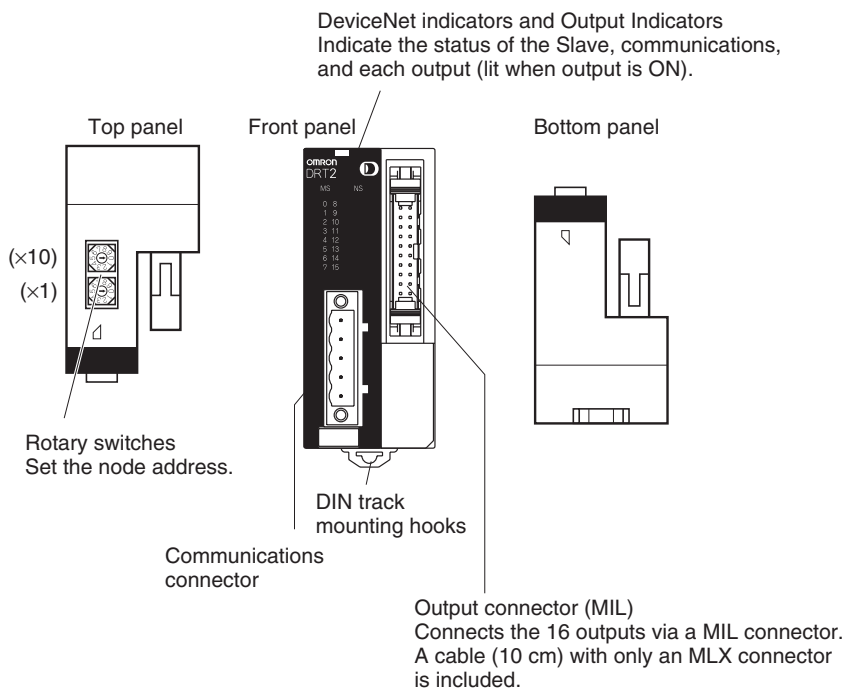

Connectors with Cable (MLX Models Only)

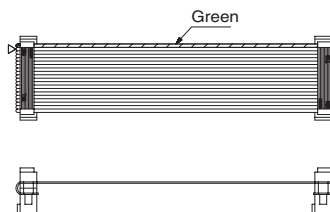

**Output Indicators**

Name	Meaning
I0 to I15	Indicate the status of bits (contacts) 0 to 15 in word m. Lit when output is ON; not lit when output is OFF.

**Note** “m” is the first word allocated to the Remote Output Terminal.

**Internal Circuits**

**DRT2-OD16ML(X) (NPN)**

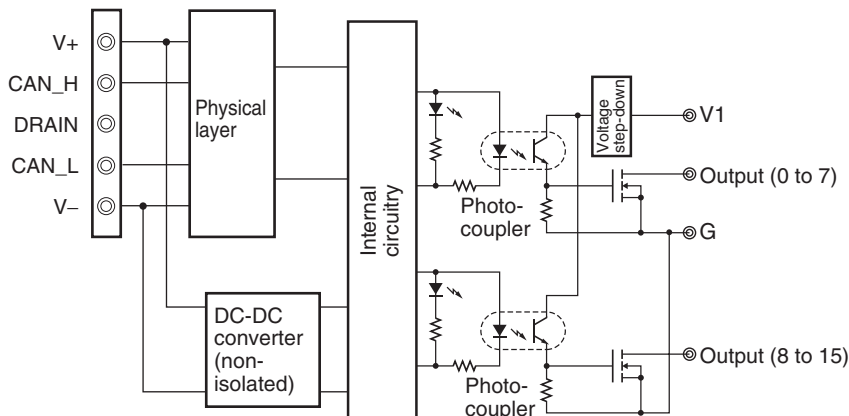

DRT2-OD16ML(X)-1 (PNP)

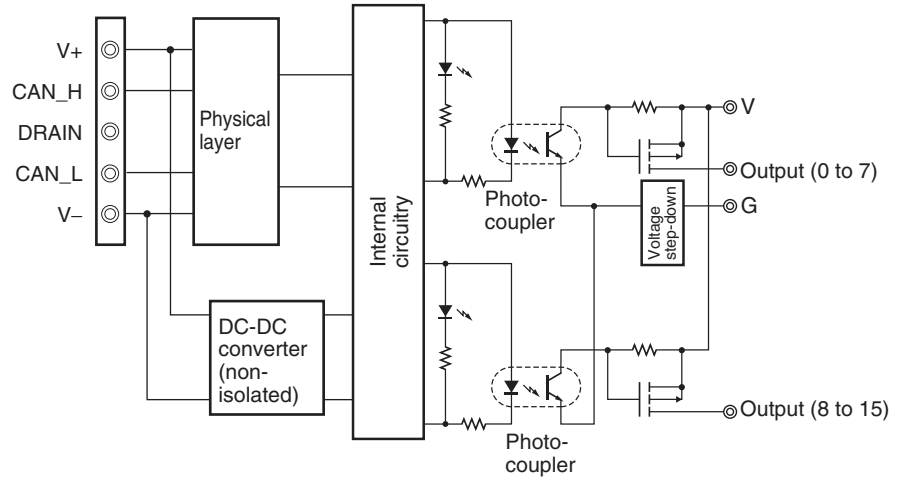

**Wiring**

DRT2-OD16ML(X) (NPN)

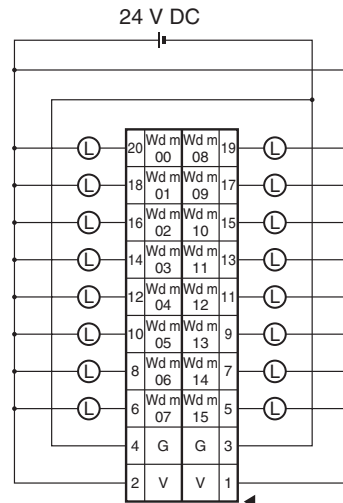

DRT2-OD16ML(X)-1 (PNP)

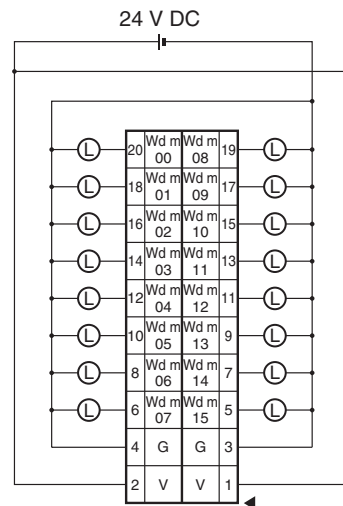

**Note** 1. The V terminals are connected internally, as are the G terminals. When the power supply exceeds 1.0 A per terminal or the total current drawn by the



external loads exceeds 2 A, the output power supply should not be input through the terminals; an external power supply must be used instead.

- When using inductive loads (such as solenoid valves), use a load with a built-in diode to absorb reverse power or attach a diode externally.

**I/O Allocations**

The first word allocated to the Remote Input Terminal is referred to as “word m.” Given this, the bit and word allocations to MIL connector pin numbers are as shown in the following diagram.

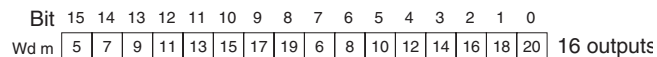

**Dimensions (DRT2-OD16ML(X) and DRT2-ID16ML(X)-1)**

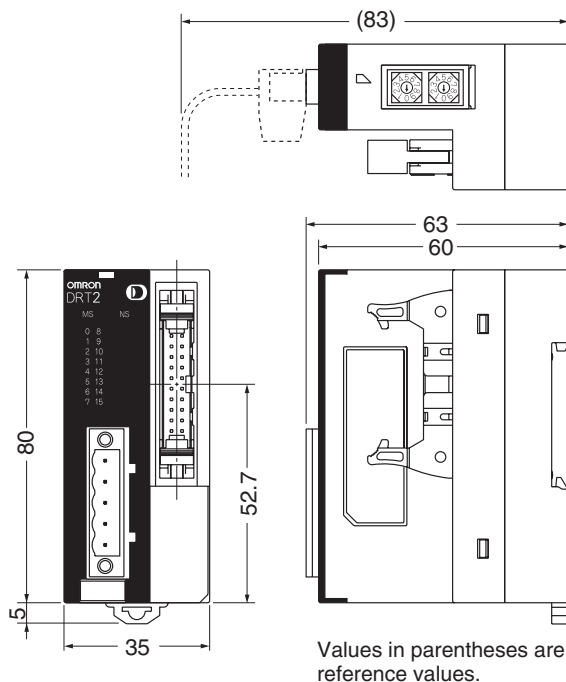

**5-6-7 Transistor Remote Input Terminals with 32 Points and Connectors: DRT2-ID32ML (NPN) and DRT2-ID32ML-1 (PNP)**

**Input Specifications**

Item	Specification	
Model	DRT2-ID32ML	DRT2-ID32ML-1
Internal I/O common	NPN	PNP
Input points	32 points	
ON voltage	17 V DC min. (between each input terminal and V)	17 V DC min. (between each input terminal and G)
OFF voltage	5 V DC max. (between each input terminal and V)	5 V DC max. (between each input terminal and G)
OFF current	1.0 mA max.	
Input current	6.0 mA max./point at 24 V DC 3.0 mA min./point at 17 V DC	
ON delay time	1.5 ms max.	
OFF delay time	1.5 ms max.	

Item	Specification
Max. simultaneously ON input points	32 points (See note.)
Number of circuits	32 points with one common

**Note** All 32 inputs can be ON simultaneously if the Remote I/O Terminal is mounted facing up, but sufficient space will need to be allowed between Units depending on the ambient temperature. Refer to the *Dimensions* diagram on page 165 for details.

**Components of the DRT2-ID32ML and DRT2-ID32ML-1**

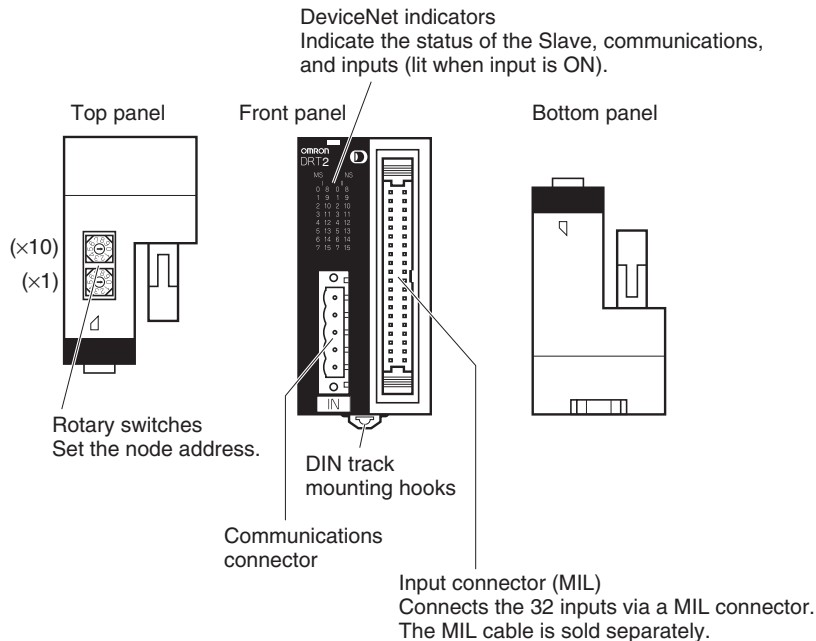

**Input Indicators**

Name	Meaning
I0 to I15	Indicate the status of bits (contacts) 0 to 15 in word m. Lit when input is ON; not lit when input is OFF.
I10 to I115	Indicate the status of bits (contacts) 0 to 15 in word m+1. Lit when input is ON; not lit when input is OFF.

**Note** "m" is the first word allocated to the Remote Input Terminal.

**Internal Circuits**

**DRT2-ID32ML (NPN)**

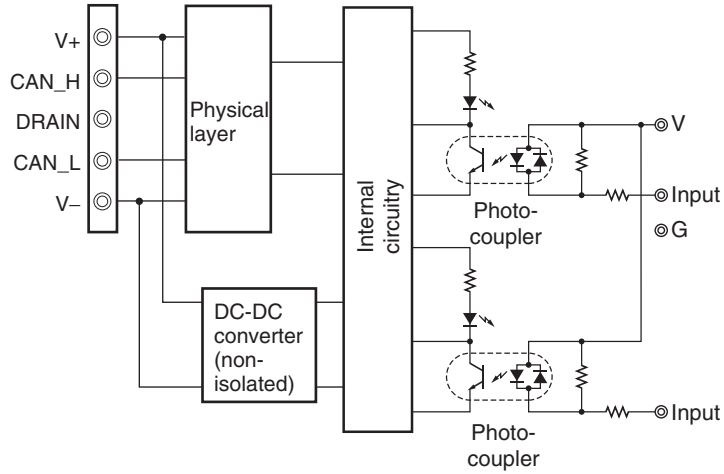

**DRT2-ID32ML-1 (PNP)**

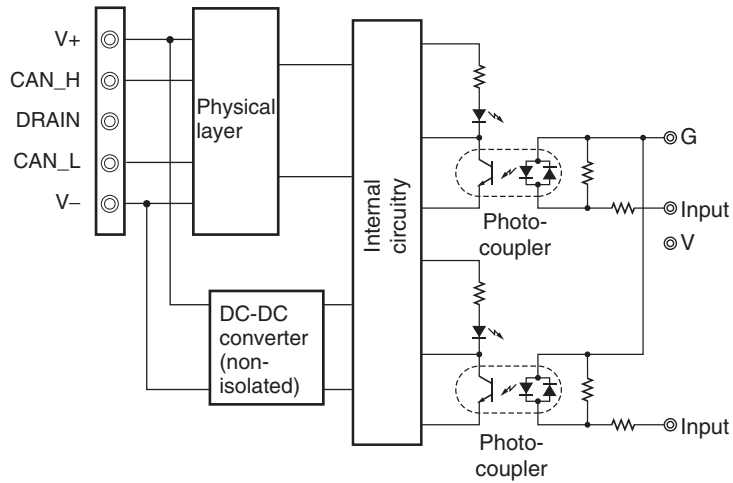

**Wiring**

**DRT2-ID32ML (NPN)**

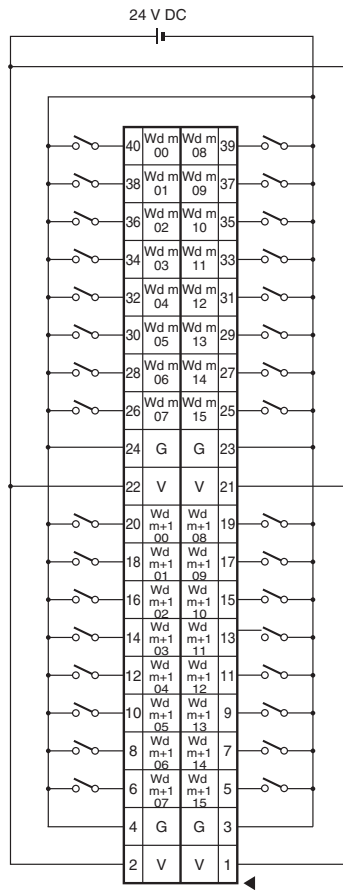

DRT2-ID32ML-1 (PNP)

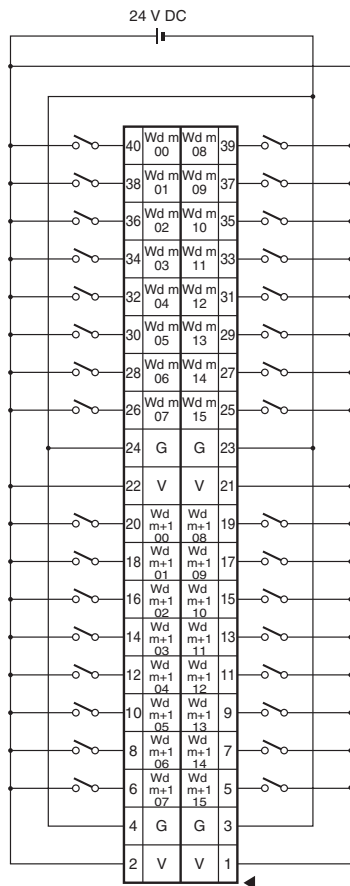

- Note**
1. V terminals are connected internally, as are the G terminals. Connect them carefully.
  2. Wire the V terminals and G terminals correctly so that the following functions operate properly.
    - I/O Power Status Monitor
    - Contact Operation Counter
    - Total ON Time Monitor
    - Function preventing malfunction caused by inrush current at startup.

If these functions are not being used, input signals will be received even if the G terminals of the DRT2-ID32ML or V terminals of the DRT2-ID32ML-1 are not connected.

**I/O Allocations**

The first word allocated to the Remote Input Terminal is referred to as “word m.” Given this, the bit and word allocations to MIL connector pin numbers are as shown in the following diagram.

	Bit 15	14	13	12	11	10	9	8	7	6	5	4	3	2	1	0	
Wd m	25	27	29	31	33	35	37	39	26	28	30	32	34	36	38	40	16 inputs
Wd m+1	5	7	9	11	13	15	17	19	6	8	10	12	14	16	18	20	16 inputs

**Dimensions (DRT2-ID32ML and DRT2-ID32ML-1)**

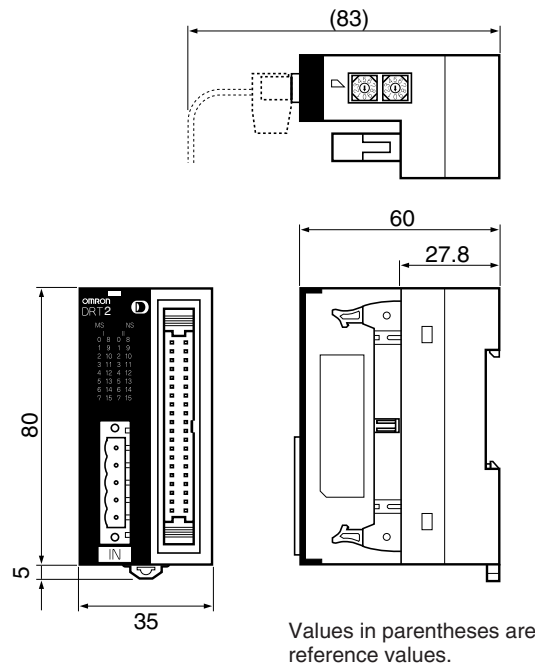

**Note** There are restriction when using the 32-point Transistor Remote Input Terminals with Connectors depending on the ambient operating temperature.

- If the Terminals are not mounted facing up, they can be mounted side-by-side and all inputs can be turned ON simultaneously at 55°C or less.
- If the Terminals are mounted facing up, the distances and temperatures in the graph given below must be maintained to enable turning ON all inputs simultaneously. For example, at an ambient temperature of 55°C, the Terminals must be separated by at least 10 mm.

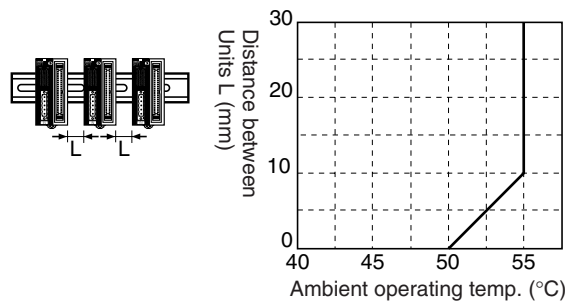

### 5-6-8 Transistor Remote Output Terminals with 32 Points and Connectors: DRT2-OD32ML (NPN) and DRT2-OD32ML-1 (PNP)

#### Output Specifications

Item	Specification	
Model	DRT2-OD32ML	DRT2-OD32ML-1
Internal I/O common	NPN	PNP
Output points	32 points	
Rated output current	0.3 A/point, 4 A/common (see note)	
Residual voltage	1.2 V max. (at 0.3 A, between each output terminal and G)	1.2 V max. (at 0.3 A, between each output terminal and V)
Leakage current	0.1 mA max.	
ON delay time	0.5 ms max.	
OFF delay time	1.5 ms max.	
Number of circuits	32 points with one common	

**Note** Do not allow the total load current to exceed 4 A and do not allow the load current on either the V or G terminal to exceed 1 A.

#### Components of the DRT2-OD32ML and DRT2-OD32ML-1

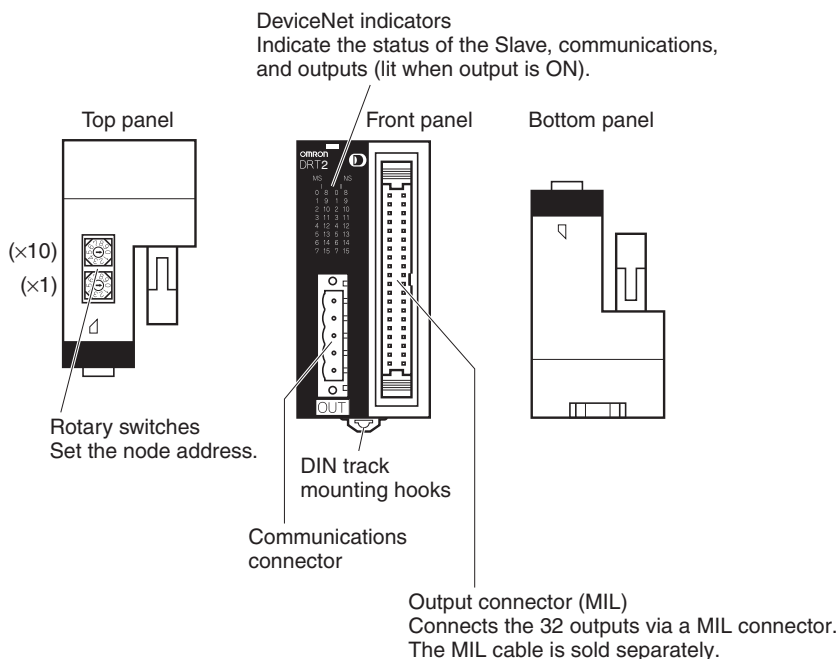

#### Output Indicators

Name	Meaning
I0 to I15	Indicate the status of bits (contacts) 0 to 15 in word m. Lit when output is ON; not lit when output is OFF.
II0 to II15	Indicate the status of bits (contacts) 0 to 15 in word m+1. Lit when output is ON; not lit when output is OFF.

**Note** “m” is the first word allocated to the Remote Output Terminal.

**Internal Circuits**

**DRT2-OD32ML (NPN)**

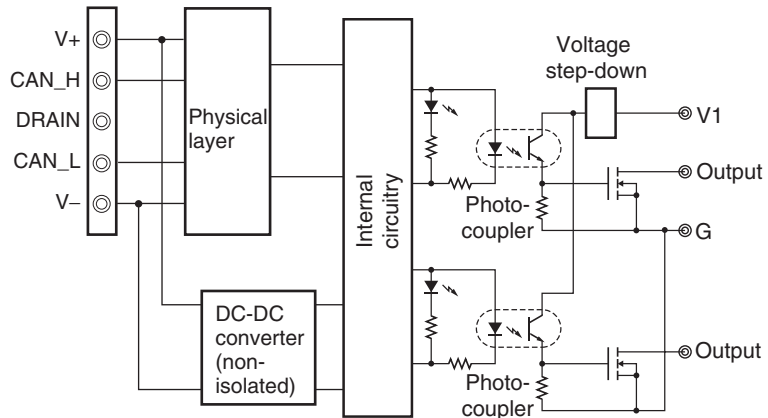

**DRT2-OD32ML-1 (PNP)**

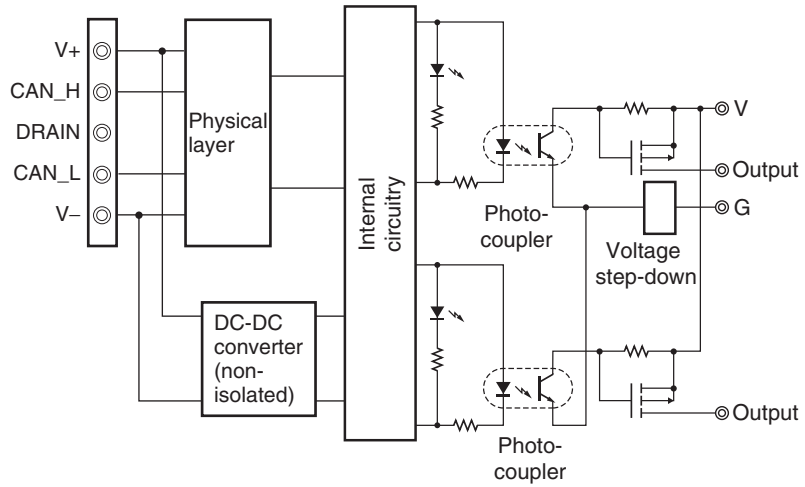



**Wiring**

**DRT2-OD32ML (NPN)**

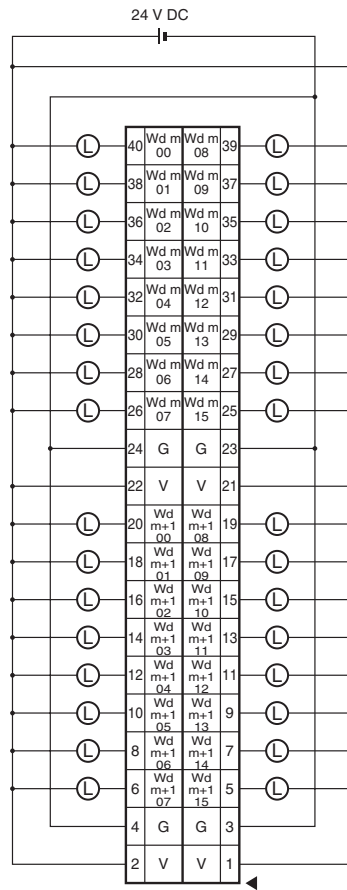

DRT2-OD32ML-1 (PNP)

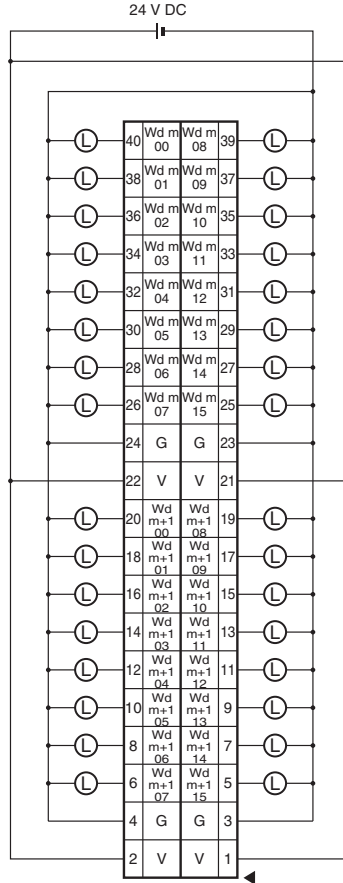

- Note**
1. The V terminals are connected internally, as are the G terminals. When the power supply exceeds 1.0 A per terminal or the total current drawn by the external loads exceeds 4 A, the output power supply should not be input through the terminals; an external power supply must be used instead.
  2. When using inductive loads (such as solenoid valves), use a load with a built-in diode to absorb reverse power or attach a diode externally.

**I/O Allocations**

The first word allocated to the Remote Output Terminal is referred to as “word m.” Given this, the bit and word allocations to MIL connector pin numbers are as shown in the following diagram.

	Bit 15	14	13	12	11	10	9	8	7	6	5	4	3	2	1	0	
Wd m	25	27	29	31	33	35	37	39	26	28	30	32	34	36	38	40	16 outputs
Wd m+1	5	7	9	11	13	15	17	19	6	8	10	12	14	16	18	20	16 outputs

**Dimensions (DRT2-OD32ML and DRT2-OD32ML-1)**

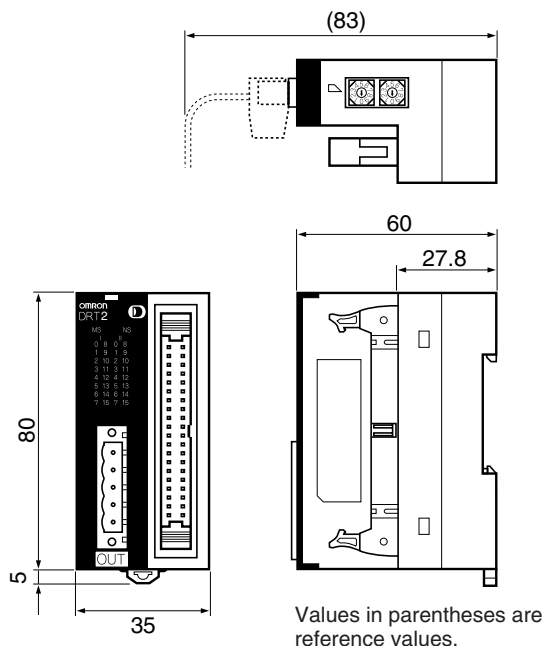

**5-6-9 Transistor Remote I/O Terminals with 16 Inputs and 16 Outputs and Connectors: DRT2-MD32ML (NPN) and DRT2-MD32ML-1 (PNP)**

**Input Specifications**

Item	Specification	
Model	DRT2-MD32ML	DRT2-MD32ML-1
Internal I/O common	NPN	PNP
Input points	16 points	
ON voltage	17 V DC min. (between each input terminal and V)	17 V DC min. (between each input terminal and G)
OFF voltage	5 V DC max. (between each input terminal and V)	5 V DC max. (between each input terminal and G)
OFF current	1.0 mA max.	
Input current	6.0 mA max./point at 24 V DC 3.0 mA min./point at 17 V DC	
ON delay time	1.5 ms max.	
OFF delay time	1.5 ms max.	
Max. No. of ON inputs	16 points	
Number of circuits	16 points with one common	

**Output Specifications**

Item	Specification	
Model	DRT2-MD32ML	DRT2-MD32ML-1
Internal I/O common	NPN	PNP
Output points	16 points	
Rated output current	0.3 A/point, 2 A/common (see note)	
Residual voltage	1.2 V max. (at 0.3 A, between each output terminal and G)	1.2 V max. (at 0.3 A, between each output terminal and V)
Leakage current	0.1 mA max.	
ON delay time	0.5 ms max.	
OFF delay time	1.5 ms max.	
Number of circuits	16 points with one common	

**Note** Do not allow the total load current to exceed 2 A and do not allow the load current on either the V or G terminal to exceed 1 A.

**Components of the DRT2-MD32ML and DRT2-MD32ML-1**

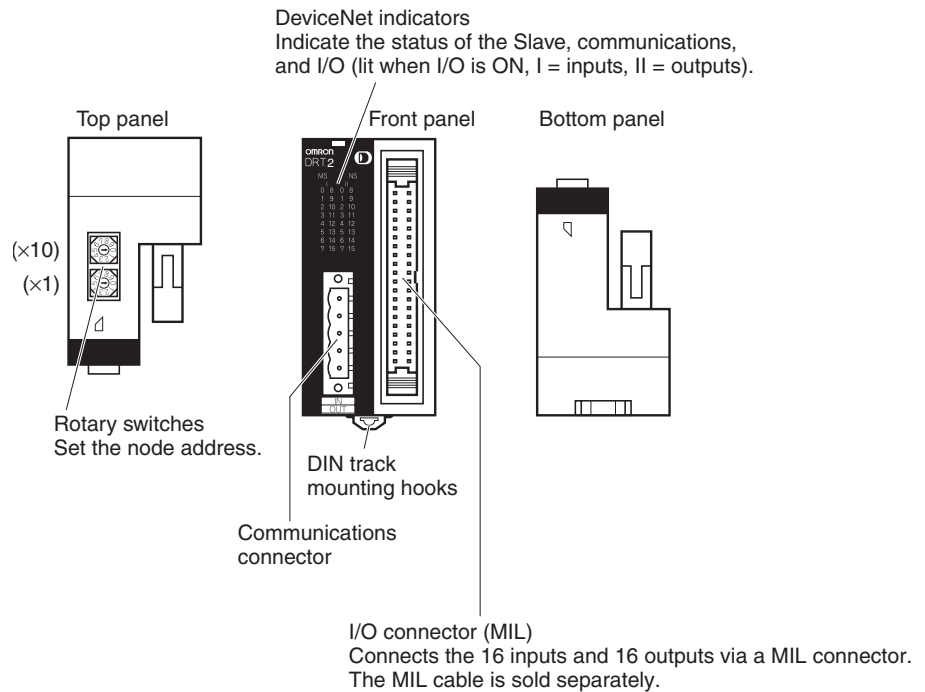

**I/O Indicators**

Name	Meaning
I0 to I15	Indicate the status of bits (contacts) 0 to 15 in word m. Lit when input is ON; not lit when input is OFF.
II0 to II15	Indicate the status of bits (contacts) 0 to 15 in word n. Lit when output is ON; not lit when output is OFF.

**Note** m: The first word allocated for the Remote I/O Terminal's IN Area.  
n: The first word allocated for the Remote I/O Terminal's OUT Area.

**Internal Circuits**

**DRT2-MD32ML (NPN)**

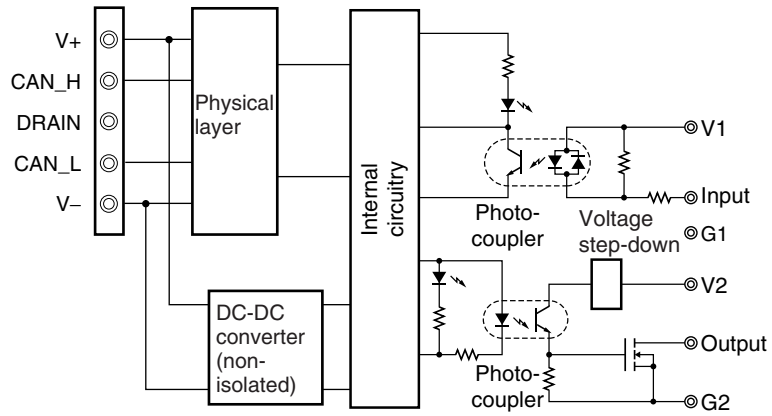

**DRT2-MD32ML-1 (PNP)**

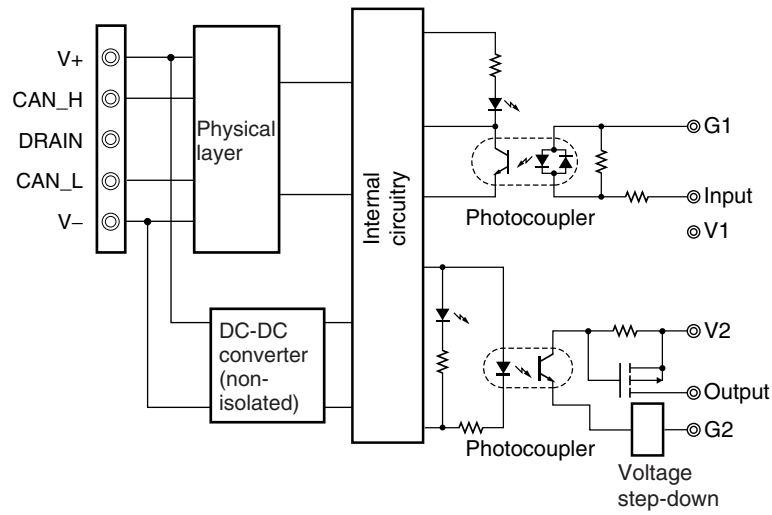

**Wiring**

**DRT2-MD32ML (NPN)**

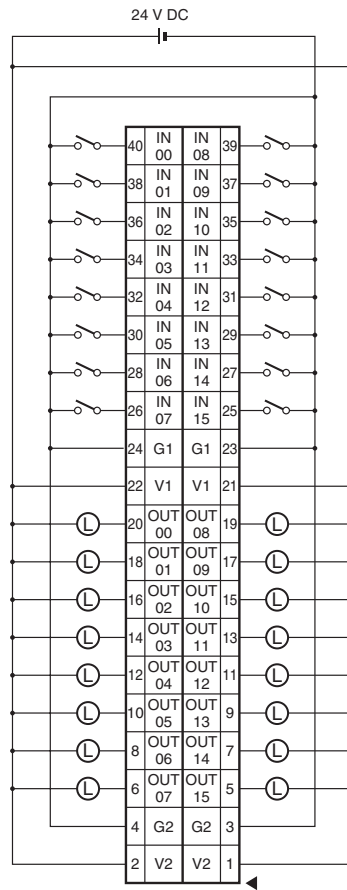

DRT2-MD32ML-1 (PNP)

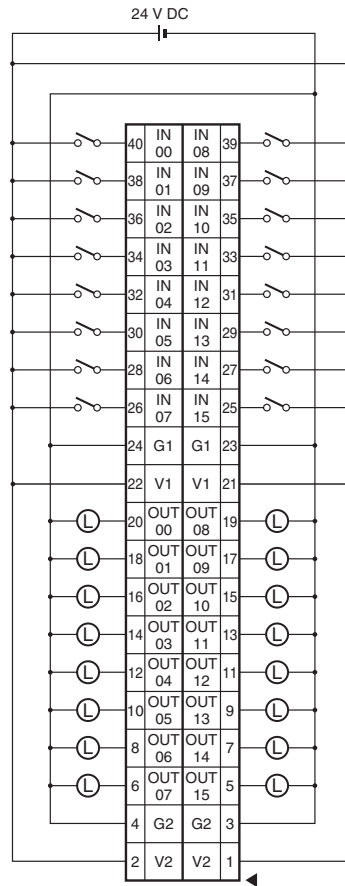

- Note**
1. The V1 terminals are connected internally, as are the V2 terminals, the G1, and the G2 terminals. (V1 is not connected to V2 and G1 is not connected to G2.) When the power supply exceeds 1.0 A per terminal or the total current drawn by the external loads exceeds 2 A, the output power supply should not be input through the terminals; an external power supply must be used instead.
  2. When using inductive loads (such as solenoid valves), use a load with a built-in diode to absorb reverse power or attach a diode externally.
  3. Wire the V1 terminals and G1 terminals correctly so that the following functions operate properly.
    - I/O Power Status Monitor
    - Contact Operation Counter
    - Total ON Time Monitor
    - Function preventing malfunction caused by inrush current at startup.

If these functions are not being used, input signals will be received even if the G1 terminals of the DRT2-ID32ML or V1 terminals of the DRT2-ID32ML-1 are not connected.

I/O Allocations

The input word and output word allocated to the Remote I/O Terminal are referred to as “word m” and “word n” respectively. Given this, the bit and word allocations to MIL connector pin numbers are as shown in the following diagram.

Bit	15	14	13	12	11	10	9	8	7	6	5	4	3	2	1	0
Wd m	25	27	29	31	33	35	37	39	26	28	30	32	34	36	38	40
Wd n	5	7	9	11	13	15	17	19	6	8	10	12	14	16	18	20

16 inputs  
16 outputs

**Dimensions (DRT2-MD32ML and DRT2-MD32ML-1)**

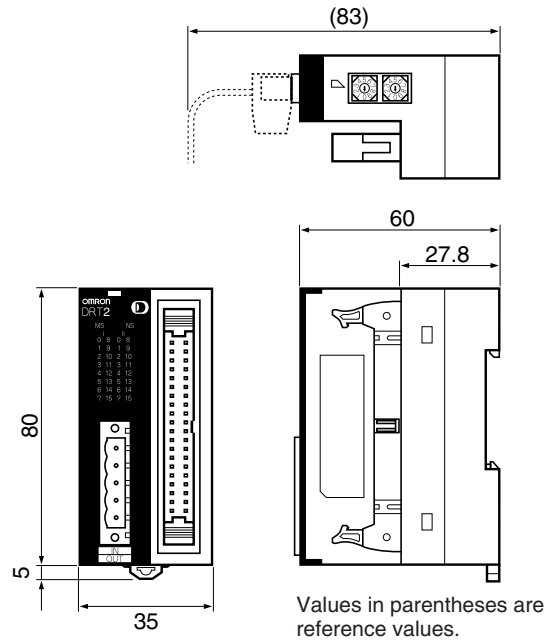

**Note** There are restriction when using the 32-point Transistor Remote I/O Terminals with Connectors depending on the ambient operating temperature.

- If the Terminals are not mounted facing up, they can be mounted side-by-side and all inputs can be turned ON simultaneously at 55°C or less.
- If the Terminals are mounted facing up, the distances and temperatures in the graph given below must be maintained to enable turning ON all inputs simultaneously. For example, at an ambient temperature of 55°C, the Terminals must be separated by at least 10 mm.

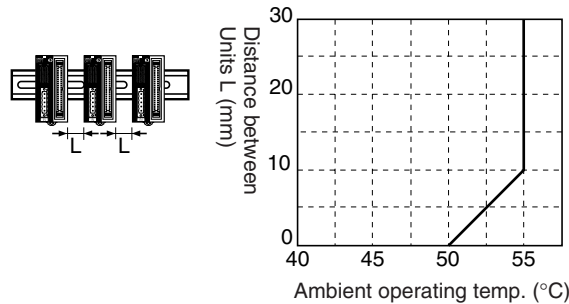



**Mounting in Control Panels**

Either of the following three methods can be used to mount an Remote I/O Terminal in a control panel.

- Mounting to DIN Track
- Mounting perpendicular to a panel using a Mounting Bracket
- Mounting parallel to a panel using a Mounting Bracket

- Note**
1. There are restriction when using the 32-point Transistor Remote I/O Terminals with Connectors or 32-point Transistor Remote Input Terminals with Connectors depending on the ambient operating temperature.
    - If the Terminals are not mounted facing up, they can be mounted side-by-side and all inputs can be turned ON simultaneously at 55°C or less.
    - If the Terminals are mounted facing up, the distances and temperatures in the graph given below must be maintained to enable turning ON all inputs simultaneously. For example, at an ambient temperature of 55°C, the Terminals must be separated by at least 10 mm.

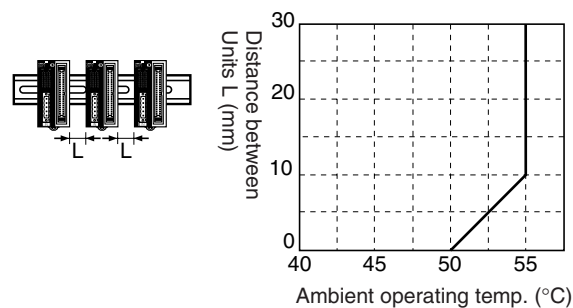

2. Remote I/O Terminals with Connectors cannot be mounted to a control panel with just screws; the SRT2-ATT02 Mounting Bracket B (sold separately) must be used.

**Mounting to DIN Track**

Mount the back of the Remote I/O Terminal to a 35-mm DIN Track. To mount the Terminal, pull down on the mounting hook on the back of the Terminal with a screwdriver, insert the DIN Track on the back of the Terminal, and then secure the Terminal to the DIN Track. When finished, secure all Slaves on both ends of the DIN Track with End Plates.

**Connecting End Plates**

Hook the bottom of the End Plate onto the DIN Track, as shown at (1) in the following diagram, then hook the top of the End Plate as shown at (2).

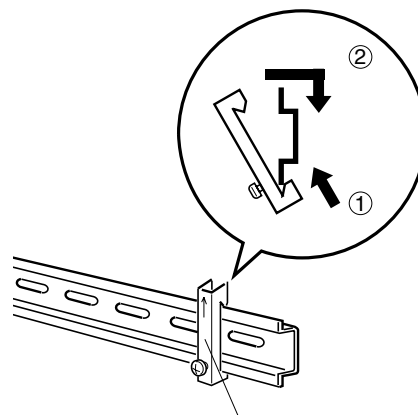

**Note** Always attach End Plate to both ends of Slaves connected to DIN Track.

**Mounting Perpendicular to a Panel Using a Mounting Bracket**

A Remote I/O Terminal with a Connector can be mounted perpendicular to a panel by using the SRT2-ATT02 Mounting Bracket B (sold separately).

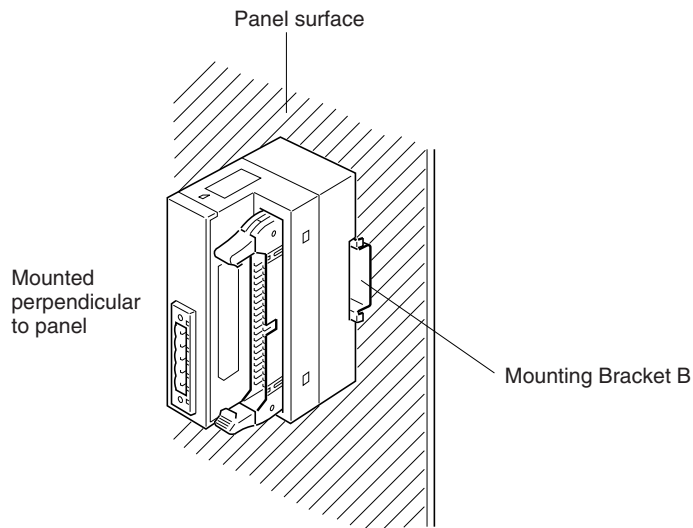

**Mounting Method**

Use the following procedure to mounted the Remote I/O Terminal.

- 1,2,3... 1. Mount the SRT2-ATT02 Mounting Bracket B to the wall using two Phillip's screws as shown below. Refer to *Mounting Bracket Dimensions* on page 180 for mounting dimensions.

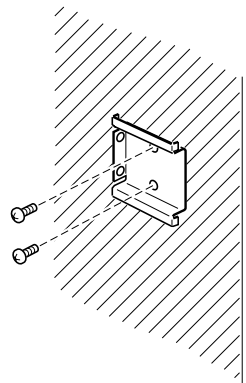

2. Mount the Remote I/O Terminal to the Mounting Bracket B. The Mounting Bracket B is shaped like a DIN Track. Use the same mounting procedure as for DIN Track.

**Mounting Holes and Slave Center Line**

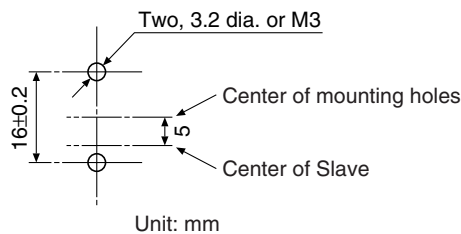

### Mounting Parallel to a Panel Using a Mounting Bracket

A Remote I/O Terminal with a Connector can be mounted parallel to a panel by using the SRT2-ATT02 Mounting Bracket B (sold separately).

**Note** A multi-drop DeviceNet connector cannot be used if the Remote I/O Terminal is mounted parallel to the panel.

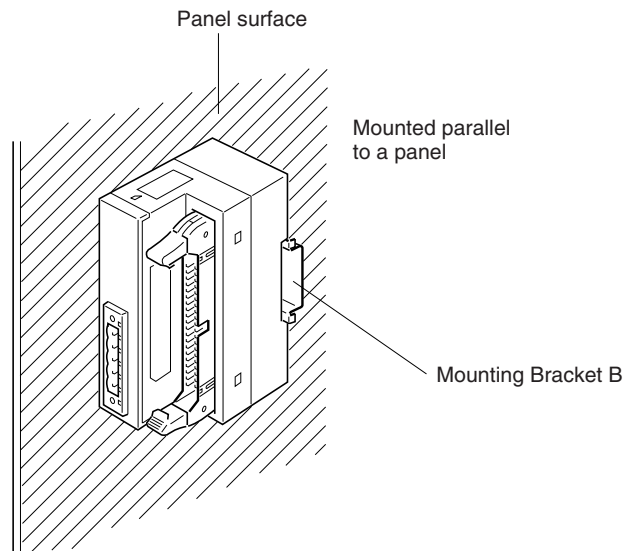

### **Mounting Method**

Use the following procedure to mount the Remote I/O Terminal.

- 1,2,3...**
1. Mount the SRT2-ATT02 Mounting Bracket B to the wall using two Phillip's screws as shown below.

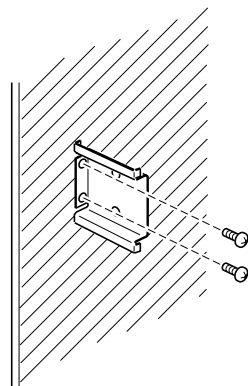

2. Mount the Remote I/O Terminal to the Mounting Bracket B. The Mounting Bracket B is shaped like a DIN Track. Use the same mounting procedure as for DIN Track.

**Note** The multi-drop wiring connector cannot be used if the Remote I/O Terminal is mounted parallel to the panel.

**Mounting Holes and Slave Center Line**

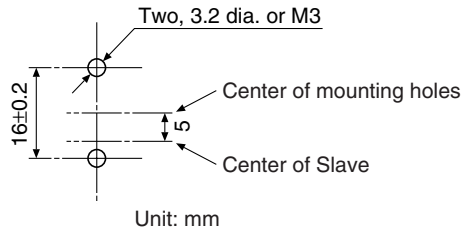

**Mounting Direction**

Unless specific restrictions are given for the Slave, it can be mounted in any direction. Any of the following directions are okay.

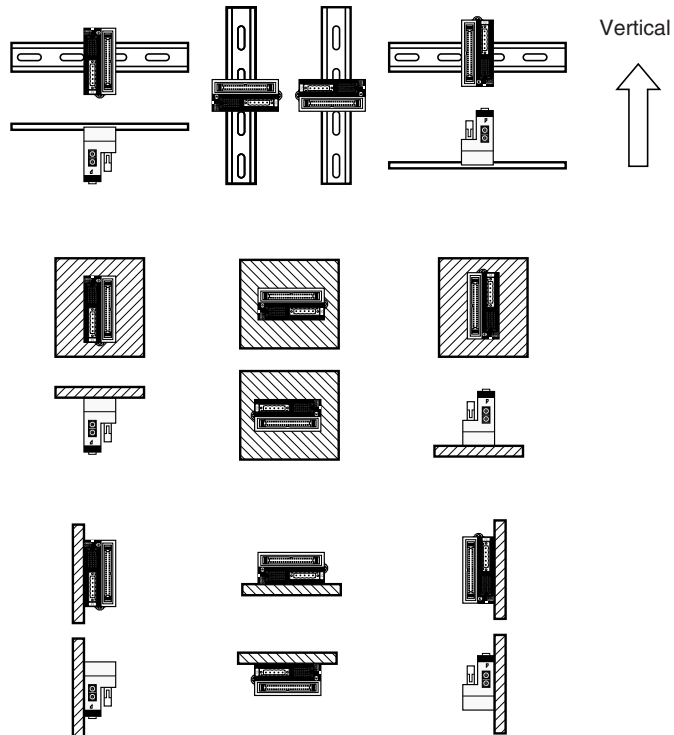

**Mounting Dimensions**

Mounted to DIN Track

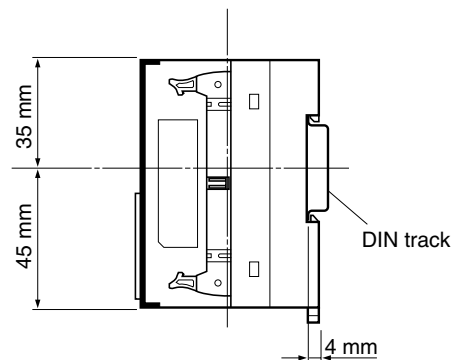

**Mounted Perpendicular to a Panel**

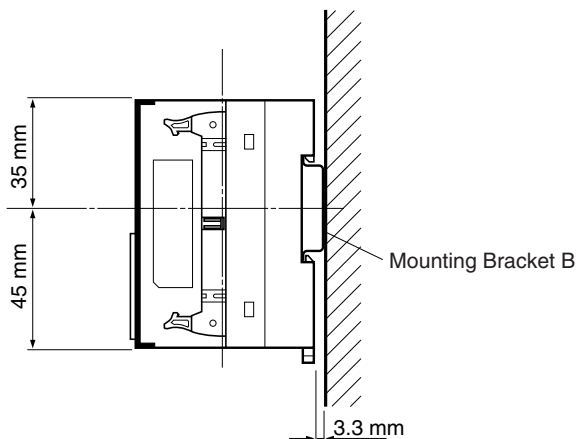

**Mounted Parallel to a Panel**

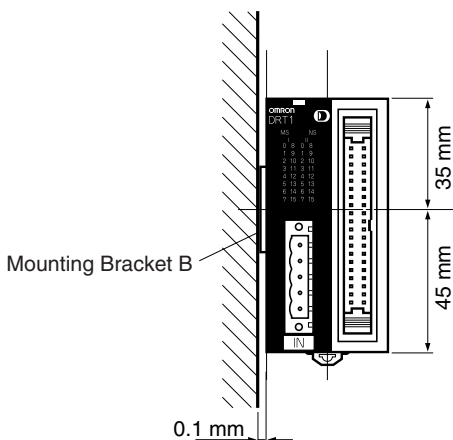

**Mounting Bracket Dimensions**

The dimensions of the SRT2-ATT02 Mounting Bracket B are shown below.

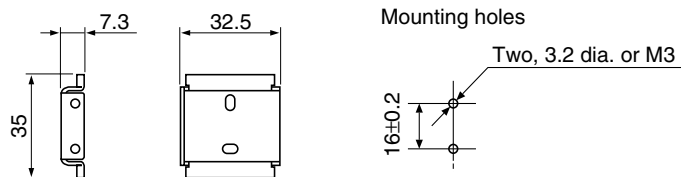

**Wiring Internal Power Supplies, I/O Power Supplies and I/O**

Internal power is supplied together with the communications power supply and does not need to be wired separately. I/O power supplies and I/O are wired through the I/O MIL connector.

**Connecting to I/O Terminals Using OMRON MIL Cables**

The MIL Cables listed in the following table are available to connect OMRON I/O Terminals (e.g., I/O Relay Blocks). Select the MIL Cable that matches the Remote I/O Terminal and the I/O Terminal.

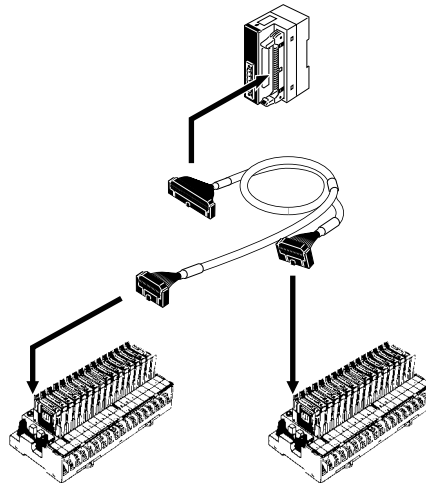

Slave	MIL Cable	I/O Relay Block or other I/O Terminal	Remarks
DRT2-ID16ML	G79-I□C	G7TC-ID16 G7TC-IA16	---
DRT2-OD16ML	G79-O□C	G7TC-OC16/OC08 G70D-SOC16/VSOC16 G70D-FOM16/VFOM16 G70A-ZOC16-3 G70D-SOC08 G70R-SOC08	---
DRT2-OD16ML-1	G79-I□C	G7TC-OC16-1	---
	G79-O□C	G70D-SOC16-1 G70D-FOM16-1 G70A-ZOC16-4	
DRT2-ID32ML	G79-I50-25-D1 (50 cm) G79-I75-50-D1 (75 cm)	G7TC-ID16 G7TC-IA16	---
DRT2-OD32ML	G79-O50-25-D1 (50 cm) G79-O75-50-D1 (75 cm)	G7TC-OC16/OC08 G70D-SOC16/VSOC16 G70D-FOM16/VFOM16 G70A-ZOC16-3 G70D-SOC08 G70R-SOC08	---
DRT2-MD32ML	G79-M50-25-D1 (50 cm) G79-M75-50-D1 (75 cm)	Inputs: G7TC-ID16/IA16 Outputs: G7TC-OC16/OC08 G70D-SOC16/VSOC16 G70D-FOM16/VFOM16 G70A-ZOC16-3 G70D-SOC08 G70R-SOC08	I/O are distinguished by color. Input tube color: Red Output tube color: Yellow
DRT2-OD32ML-1	G79-O50-25-D1 (50 cm) G79-O75-50-D1 (75 cm)	G70D-SOC16-1 G70D-FOM16-1 G70A-ZOC16-4	---
	G79-I50-25-D1 (50 cm) G79-I75-50-D1 (75 cm)	G7TC-OC16-1	---
DRT2-MD32ML-1	G79-M50-25-D2 (50 cm) G79-M75-50-D2 (75 cm)	Inputs: G70A-ZIM16-5 Outputs: G70D-SOC16-1 G70D-FOM16-1 G70A-ZOC16-4	I/O are distinguished by color. Input tube color: Red Output tube color: Yellow

The following cables are also available with a MIL connector on the Remote I/O Terminal end and loose wires on the other end.

MIL Cable	Remarks
G79-A200C-D1 (2 m) G79-A500C-D1 (5 m)	Loose wire size: AWG28 Loose wires are cut.
G79-Y100C-D1 (1 m) G79-Y200C-D1 (2 m) G79-Y500C-D1 (5 m)	Forked terminals are attached to the loose wires. Forked terminals: 161071-M2 (Nippon Terminal)

The MIL pin numbers, loose wire colors, dot markings, and dot colors are listed in the following table.

Pin No.	Core color	Dot marking	Dot color	Pin No.	Core color	Dot marking	Dot color
1	Light brown	■	Black	21	Light brown	■ ■ ■	Black
2	brown		Red	22	brown		Red
3	Yellow		Black	23	Yellow		Black
4			Red	24			Red
5	Light green		Black	25	Light green		Black
6	green		Red	26	green		Red
7	Gray		Black	27	Gray		Black
8			Red	28			Red
9	White		Black	29	White		Black
10			Red	30			Red
11	Light brown	■ ■	Black	31	Light brown	■ ■ ■ ■	Black
12	brown		Red	32	brown		Red
13	Yellow		Black	33	Yellow		Black
14			Red	34			Red
15	Light green		Black	35	Light green		Black
16	green		Red	36	green		Red
17	Gray		Black	37	Gray		Black
18			Red	38			Red
19	White		Black	39	White		Black
20			Red	40			Red

**Using Pressure-welded Flat Cable Connectors**

Use the following procedure to prepare flat cables with XG4M-4030-T MIL Connectors.

1,2,3...

1. Use precision screwdrivers to open the hooks on both ends and separate the contacts from the cover of the MIL socket. There are two tabs on each end of the contact side of the socket. Release both of these at the same time, not one at a time.

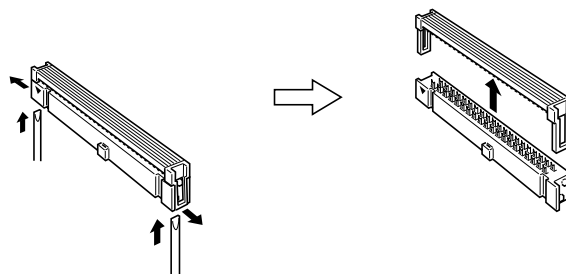

2. Place the flat cable between the contacts and cover of the socket, align the contacts, and press on the cover to lock it in place on the contacts. Use a

vise or similar device to firmly press the cover on until the tabs are properly joined.

Applicable Wires: 1.27-mm pitch flat cable, AWG28 (7-strand wire)

UL2651: Standard Cable, UL20012: Stranded Cable, UL20028: Color Coded Cable

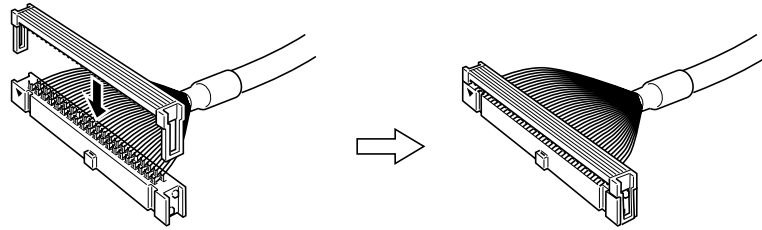

3. If required, fold the back over the connector, and insert and lock a strain relief in place.

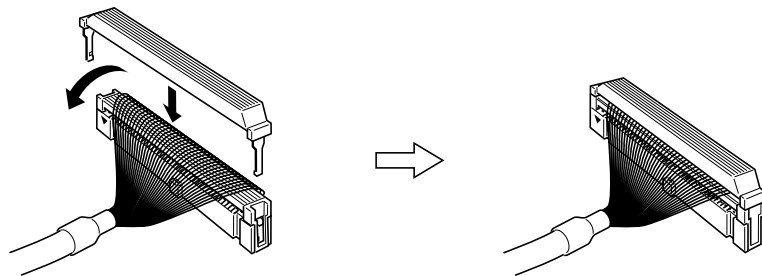

4. Connect the MIL Connector to a Remote I/O Terminal with a Connector.

**Using Loose Wires with Pressure-welded Connectors**

Use the following parts to prepare cables. The Socket used depends on the wire size.

Part	Cable wire size: AWG24	Cable wire size: AWG26 to 26
Socket	XG5M-4032-N	XG5M-4035-N
Semi-cover (See note 1.)	XG5S-2001	
Hood Cover (See note 2.)	XG5S-5022	

- Note**
1. Two Semi-covers are required for each connector.
  2. A multi-drop DeviceNet Connector cannot be used if the Hood Cover is used.

Refer to the *PCB Relays Catalog (X33)* for details on the XG5 Loose Wire Pressure-welded Connectors.



### 5-6-10 Board-type Connector Terminals with 32 Inputs and MIL Connectors: DRT2-ID32B (NPN)/DRT2-ID32B-1 (PNP) and DRT2-ID32BV (NPN)/DRT2-ID32BV-1 (PNP)

#### Input Specifications

Item	Specification	
Model	DRT2-ID32B DRT2-ID32BV	DRT2-ID32B-1 DRT2-ID32BV-1
Internal I/O common	NPN	PNP
Input points	32 points	
ON voltage	17 V DC min. (between each input terminal and V)	17 V DC min. (between each input terminal and G)
OFF voltage	5 V DC max. (between each input terminal and V)	5 V DC max. (between each input terminal and G)
OFF current	1.0 mA max.	
Input current	6.0 mA max. at 24 V DC 3.0 mA min. at 17 V DC (between each input terminal and V terminal)	6.0 mA max. at 24 V DC 3.0 mA min. at 17 V DC (between each input terminal and G terminal)
ON delay time	1.5 ms max.	
OFF delay time	1.5 ms max.	
Max. simultaneously ON input points	32 points	
Number of circuits	32 points with one common circuit	

#### Components

#### DRT2-ID32B (NPN)/DRT2-ID32B-1 (PNP)      DRT2-ID32BV (NPN)/DRT2-ID32BV-1 (PNP)

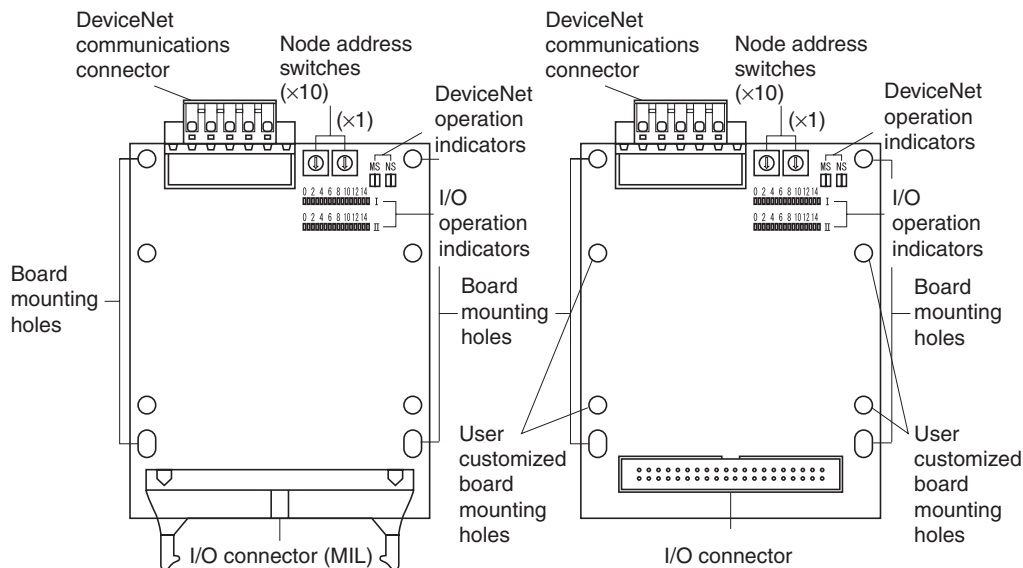

#### Input Indicators

Name	Meaning
I0 to I15	Indicate the status of bits (contacts) 0 to 15 in word m. Lit when input is ON; not lit when input is OFF.
II0 to II15	Indicate the status of bits (contacts) 0 to 15 in word m+1. Lit when input is ON; not lit when input is OFF.

**Note** “m” is the first word allocated to the Remote I/O Terminal.

**Internal Circuits**

**DRT2-ID32B and DRT2-ID32BV (NPN)**

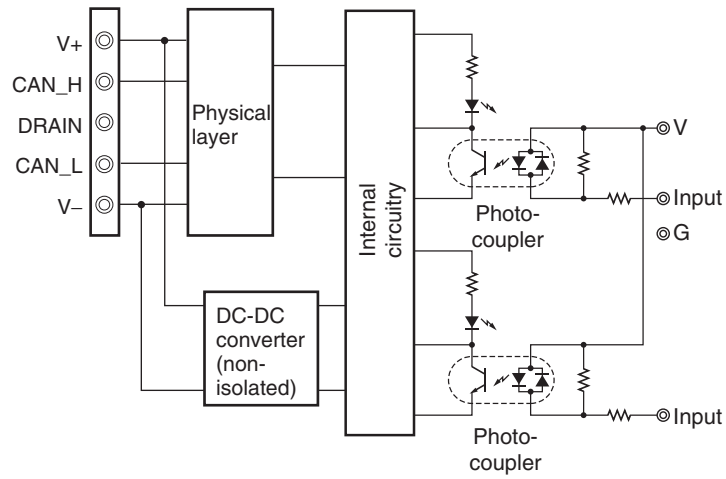

**DRT2-ID32B-1 and DRT2-ID32BV-1 (PNP)**

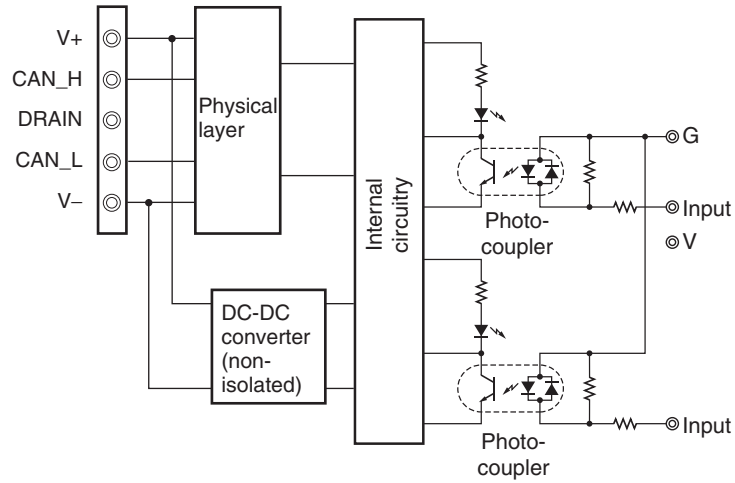

**Wiring**

**DRT2-ID32B and DRT2-ID32BV (NPN)**

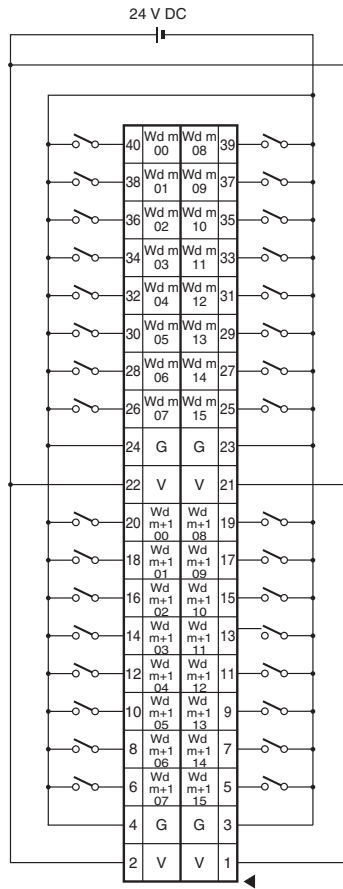

DRT2-ID32B-1 and DRT2-ID32BV-1 (PNP)

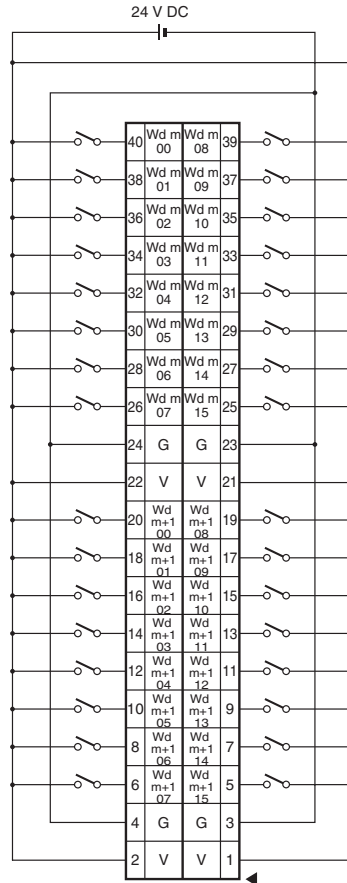

- Note**
1. V terminals are connected internally, as are the G terminals. Connect them carefully.
  2. Wire the V terminals and G terminals correctly so that the following functions operate properly.
    - I/O Power Status Monitor
    - Contact Operation Counter
    - Total ON Time Monitor
    - Function preventing malfunction caused by inrush current at startup.

If these functions are not being used, input signals will be received even if the G terminals of the DRT2-ID32B and DRT2-ID32BV or V terminals of the DRT2-ID32B-1 and DRT2-ID32BV-1 are not connected.

**I/O Allocations**

The first word allocated to the Remote I/O Terminal is referred to as “word m.” Given this, the bit and word allocations to MIL connector pin numbers are as shown in the following diagram.

	Bit 15	14	13	12	11	10	9	8	7	6	5	4	3	2	1	0	
Wd m	25	27	29	31	33	35	37	39	26	28	30	32	34	36	38	40	16 inputs
Wd m+1	5	7	9	11	13	15	17	19	6	8	10	12	14	16	18	20	16 inputs

**Dimensions**

DRT2-ID32B (NPN)/DRT2-ID32B-1 (PNP)    DRT2-ID32BV (NPN)/DRT2-ID32BV-1 (PNP)

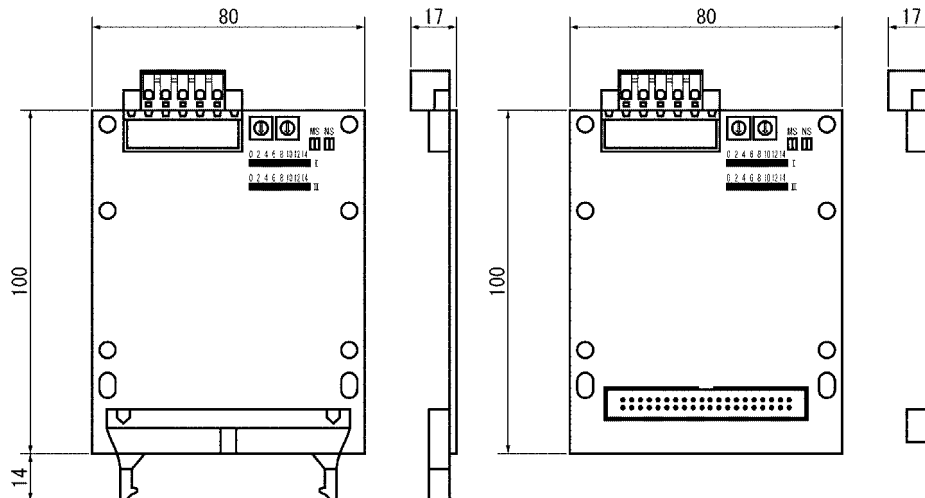

**5-6-11 Board-type Connector Terminals with 32 Outputs and MIL Connectors: DRT2-OD32B (NPN)/DRT2-OD32B-1 (PNP) and DRT2-OD32BV (NPN)/DRT2-OD32BV-1 (PNP)**

**Output Specifications**

Item	Specification	
Model	DRT2-OD32B DRT2-OD32BV	DRT2-OD32B-1 DRT2-OD32BV-1
Internal I/O common	NPN	PNP
Output points	32 points	
Rated output current	0.3 A/point, 4 A/common (See note.)	
Residual voltage	1.2 V max. (at 0.3 A, between each output terminal and G)	1.2 V max. (at 0.3 A, between each output terminal and V)
Leakage current	0.1 mA max.	0.1 mA max.
ON delay time	0.5 ms max.	
OFF delay time	1.5 ms max.	
Number of circuits	32 points with one common circuit	

**Note** Do not allow the total load current to exceed 4 A and do not allow the load current on either the V or G terminal to exceed 1 A.

**Components**

**DRT2-OD32B (NPN)/DRT2-OD32B-1 (PNP) DRT2-OD32BV (NPN)/DRT2-OD32BV-1 (PNP)**

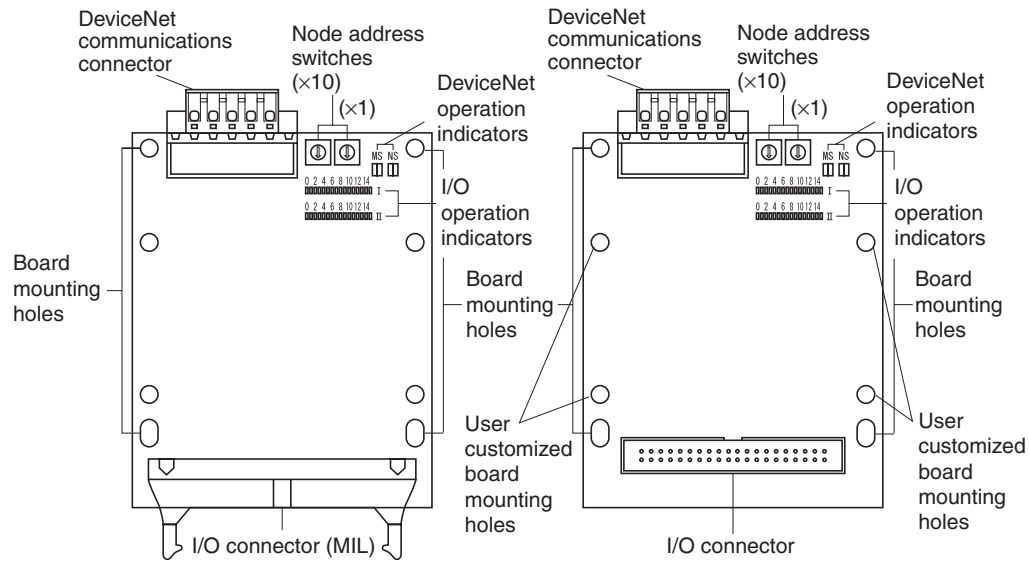

**Output Indicators**

Name	Meaning
I0 to I15	Indicate the status of bits (contacts) 0 to 15 in word m. Lit when output is ON; not lit when output is OFF.
II0 to II15	Indicate the status of bits (contacts) 0 to 15 in word m+1. Lit when output is ON; not lit when output is OFF.

**Note** “m” is the first word allocated to the Remote I/O Terminal.

**Internal Circuits**

**DRT2-OD32B and DRT2-OD32BV (NPN)**

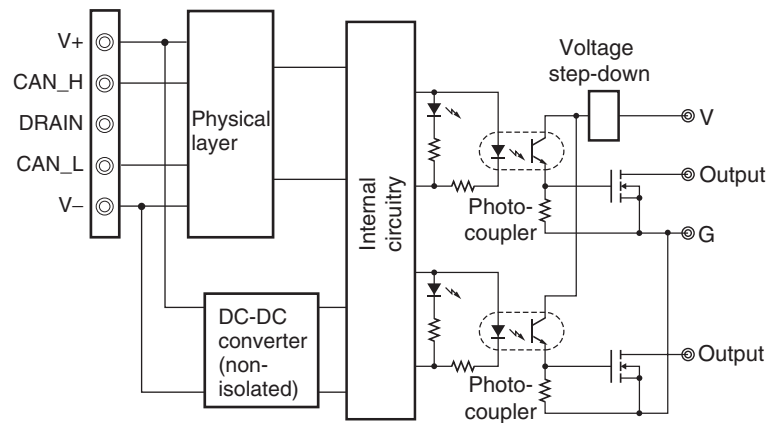

**DRT2-OD32B-1 and DRT2-OD32BV-1 (PNP)**

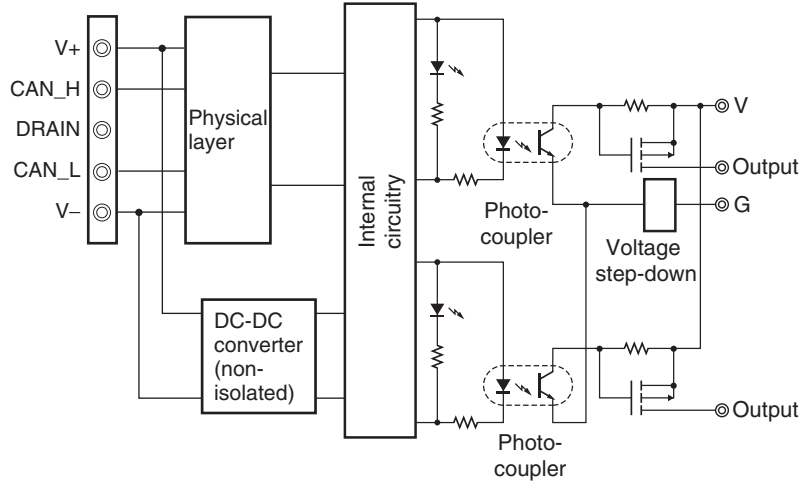

**Wiring**

**DRT2-OD32B and DRT2-OD32BV (NPN)**

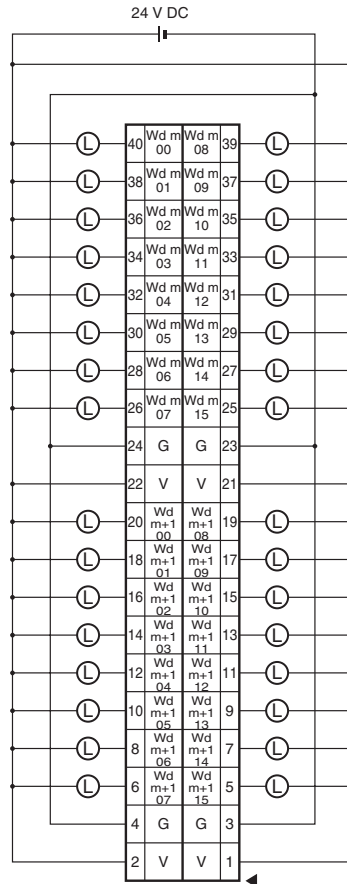

DRT2-OD32B-1 and DRT2-OD32BV-1 (PNP)

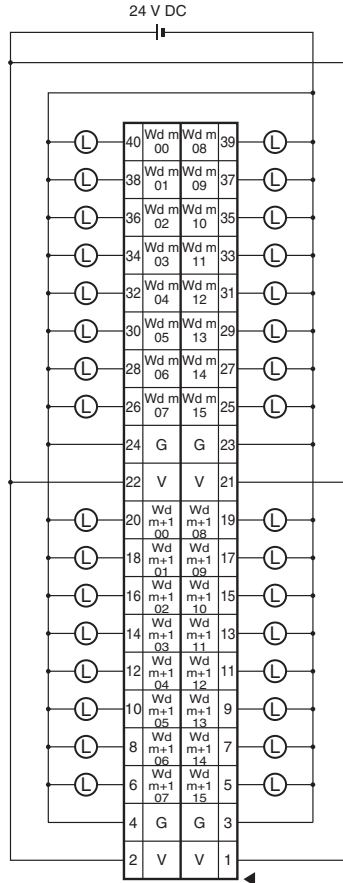

- Note**
1. The V terminals are connected internally, as are the G terminals. When the power supply exceeds 1.0 A per terminal or the total current drawn by the external loads exceeds 4 A, the output power supply should not be input through the terminals; an external power supply must be used instead.
  2. When using inductive loads (such as solenoid valves), use a load with a built-in diode to absorb reverse power or attach a diode externally.

**I/O Allocations**

The first word allocated to the Remote I/O Terminal is referred to as “word m.” Given this, the bit and word allocations to MIL connector pin numbers are as shown in the following diagram.

	Bit	15	14	13	12	11	10	9	8	7	6	5	4	3	2	1	0	
Wd m		25	27	29	31	33	35	37	39	26	28	30	32	34	36	38	40	16 outputs
Wd m+1		5	7	9	11	13	15	17	19	6	8	10	12	14	16	18	20	16 outputs



**Dimensions**

DRT2-OD32B (NPN)/DRT2-OD32B-1 (PNP) DRT2-OD32BV (NPN)/DRT2-OD32BV-1 (PNP)

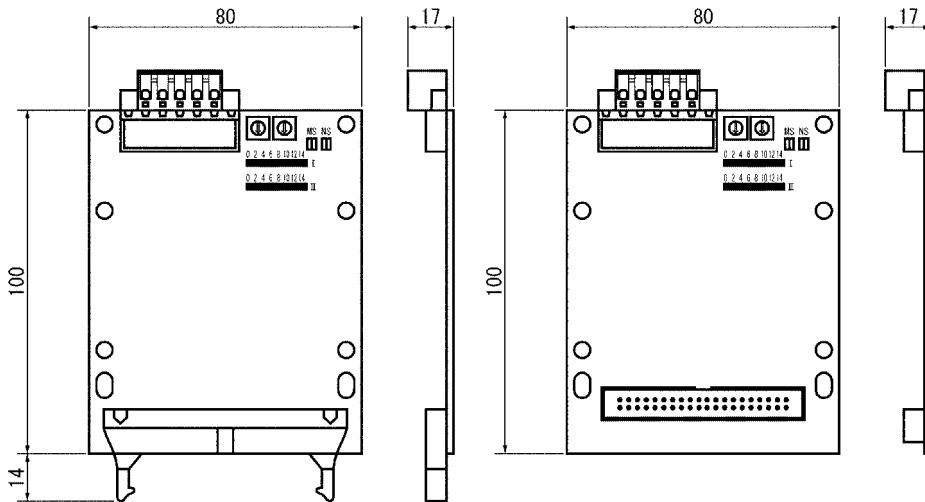

**5-6-12 Board-type Connector Terminals with 16 Inputs, 16 Outputs and MIL Connectors: DRT2-MD32B (NPN)/DRT2-MD32B-1 (PNP) and DRT2-MD32BV (NPN)/DRT2-MD32BV-1 (PNP)**

**Input Specifications**

Item	Specification	
Model	DRT2-MD32B DRT2-MD32BV	DRT2-MD32B-1 DRT2-MD32BV-1
Internal I/O common	NPN	PNP
Input points	16 points	
ON voltage	17 V DC min. (between each input terminal and V)	17 V DC min. (between each input terminal and G)
OFF voltage	5 V DC max. (between each input terminal and V)	5 V DC max. (between each input terminal and G)
OFF current	1.0 mA max.	
Input current	6.0 mA max. at 24 V DC 3.0 mA min. at 17 V DC (between each input terminal and V terminal)	6.0 mA max. at 24 V DC 3.0 mA min. at 17 V DC (between each input terminal and G terminal)
ON delay time	1.5 ms max.	
OFF delay time	1.5 ms max.	
Max. No. of ON inputs	16 points	
Number of circuits	16 points with one common circuit	

**Output Specifications**

Item	Specification	
Model	DRT2-MD32B DRT2-MD32BV	DRT2-MD32B-1 DRT2-MD32BV-1
Internal I/O common	NPN	PNP
Output points	16 points	
Rated output current	0.3 A/point, 2 A/common (See note.)	
Residual voltage	1.2 V max. (at 0.3 A, between each output terminal and G)	1.2 V max. (at 0.3 A, between each output terminal and V)
Leakage current	0.1 mA max.	0.1 mA max.
ON delay time	0.5 ms max.	
OFF delay time	1.5 ms max.	
Number of circuits	16 points with one common circuit	

**Note** Do not allow the total load current to exceed 2 A and do not allow the load current on either the V or G terminal to exceed 1 A.

**Components**

**DRT2-MD32B (NPN)/DRT2-MD32B-1 (PNP) DRT2-MD32BV (NPN)/DRT2-MD32BV-1 (PNP)**

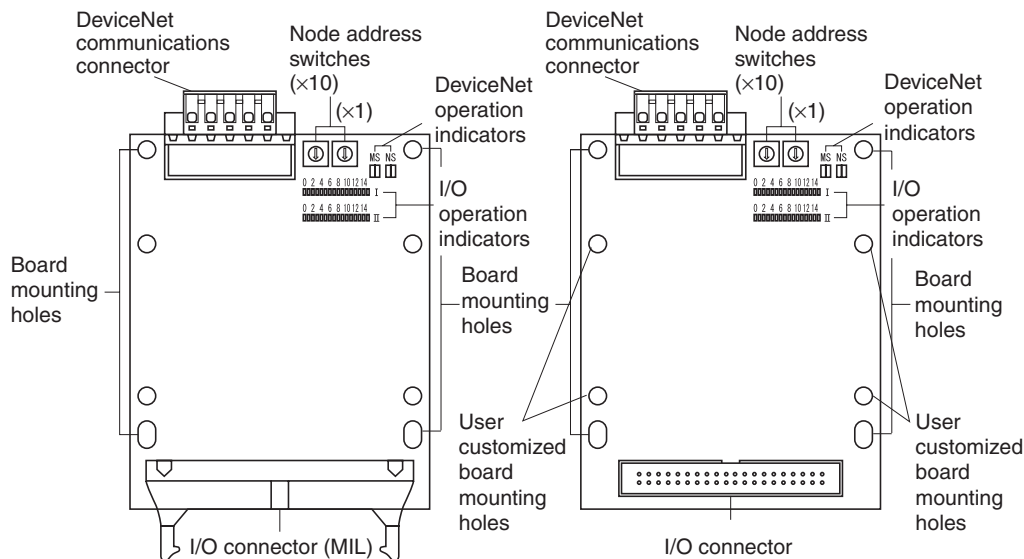

**I/O Indicators**

Name	Meaning
I0 to I15	Indicate the status of bits (contacts) 0 to 15 in word m. Lit when input is ON; not lit when input is OFF.
II0 to II15	Indicate the status of bits (contacts) 0 to 15 in word n. Lit when output is ON; not lit when output is OFF.

**Note** m: The first word allocated for the Remote I/O Terminal's IN Area.  
n: The first word allocated for the Remote I/O Terminal's OUT Area.

**Internal Circuits**

**DRT2-MD32B and DRT2-MD32BV (NPN)**

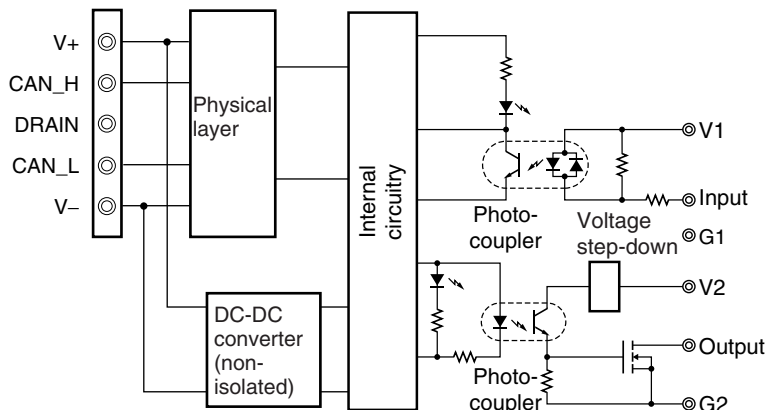

**DRT2-MD32B-1 and DRT2-MD32BV-1 (PNP)**

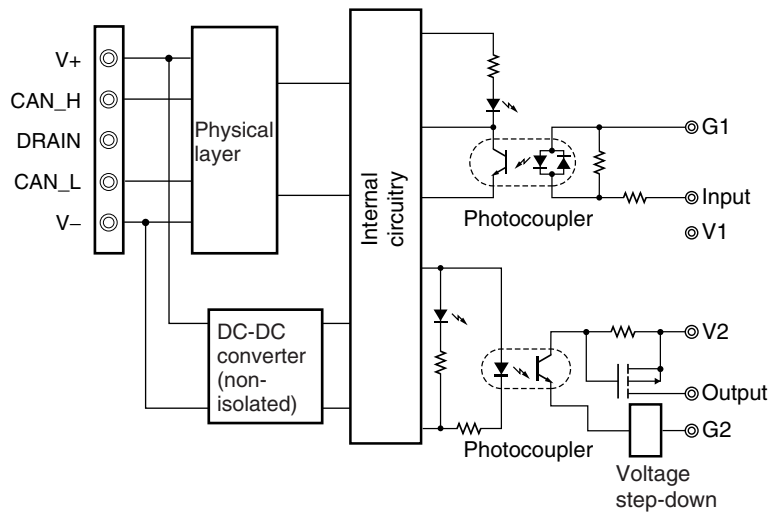

**Wiring**

**DRT2-MD32B and DRT2-MD32BV (NPN)**

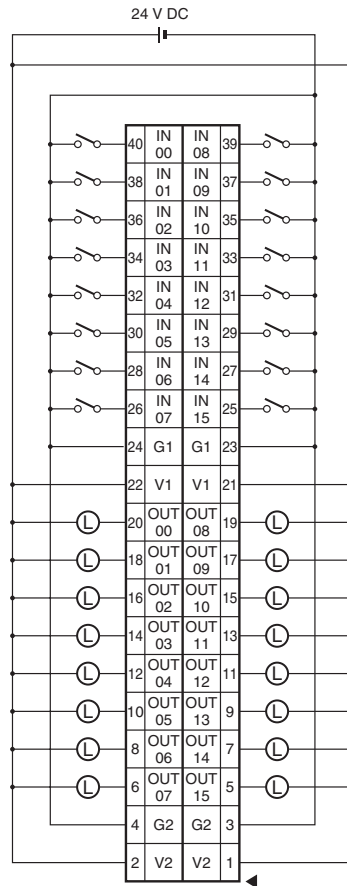

DRT2-MD32B-1 and DRT2-MD32BV-1 (PNP)

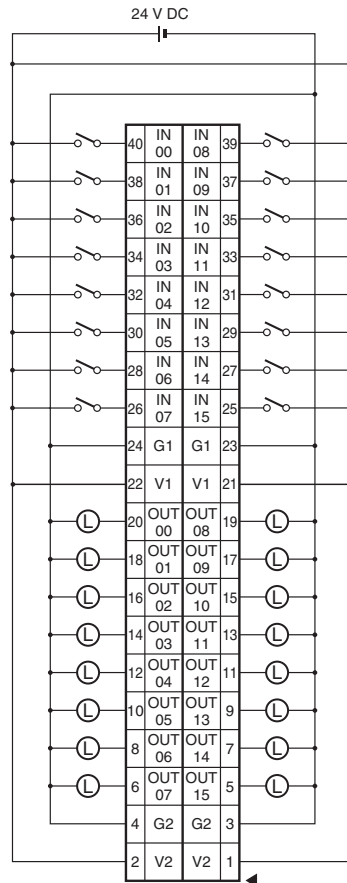

- Note**
1. The V1 terminals are connected internally, as are the V2 terminals, the G1, and the G2 terminals. (V1 is not connected to V2 and G1 is not connected to G2.) When the power supply exceeds 1.0 A per terminal or the total current drawn by the external loads exceeds 2 A, the output power supply should not be input through the terminals; an external power supply must be used instead.
  2. When using inductive loads (such as solenoid valves), use a load with a built-in diode to absorb reverse power or attach a diode externally.
  3. Wire the V1 terminals and G1 terminals correctly so that the following functions operate properly.
    - I/O Power Status Monitor
    - Contact Operation Counter
    - Total ON Time Monitor
    - Function preventing malfunction caused by inrush current at startup.

If these functions are not being used, input signals will be received even if the G1 terminals of the DRT2-MD32B/DRT2-MD32BV or V1 terminals of the DRT2-MD32B-1/DRT2-MD32BV-1 are not connected.

**I/O Allocations**

The input word and output word allocated to the Remote I/O Terminal are referred to as “word m” and “word n” respectively. Given this, the bit and word allocations to MIL connector pin numbers are as shown in the following diagram.

	Bit	15	14	13	12	11	10	9	8	7	6	5	4	3	2	1	0	
Wd m		25	27	29	31	33	35	37	39	26	28	30	32	34	36	38	40	16 inputs
Wd n		5	7	9	11	13	15	17	19	6	8	10	12	14	16	18	20	16 outputs

**Dimensions**

**DRT2-MD32B (NPN)/DRT2-MD32B-1 (PNP) DRT2-MD32BV (NPN)/DRT2-MD32BV-1 (PNP)**

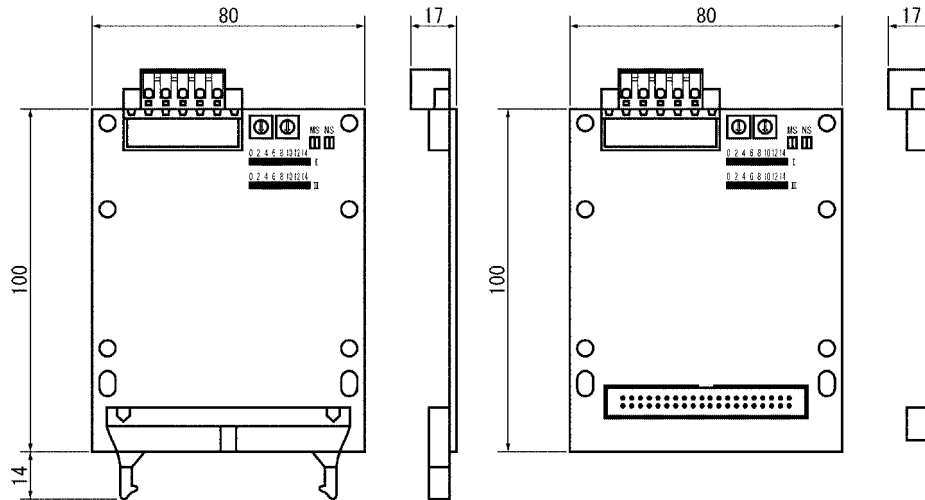

**User Customized Boards**

A board can be created by the user and mounted to the DRT2-□D32BV(-1). This allows the user to create the required I/O system by placing I/O connectors, relays, and other components as necessary on the board and then mounting the board to a Board Terminal. The following diagram illustrates mounting a customized user board to the DRT2-□D32BV(-1).

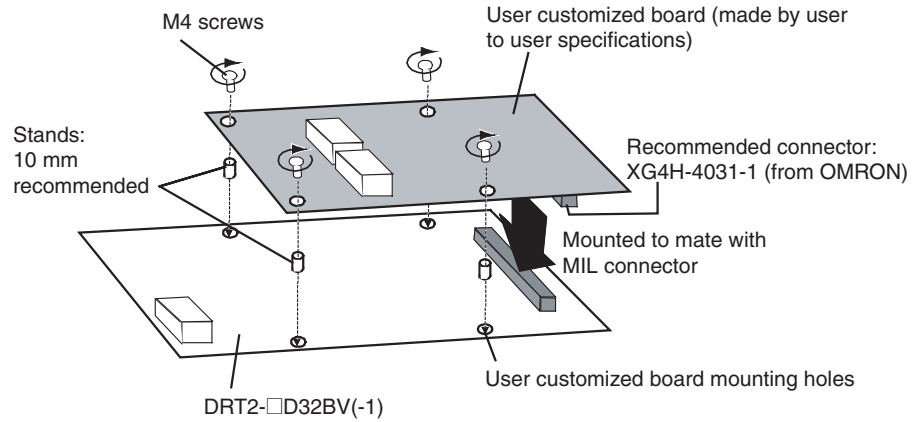

**User Customized Board Dimensions**

Cut the user customized board to the dimensions shown below.

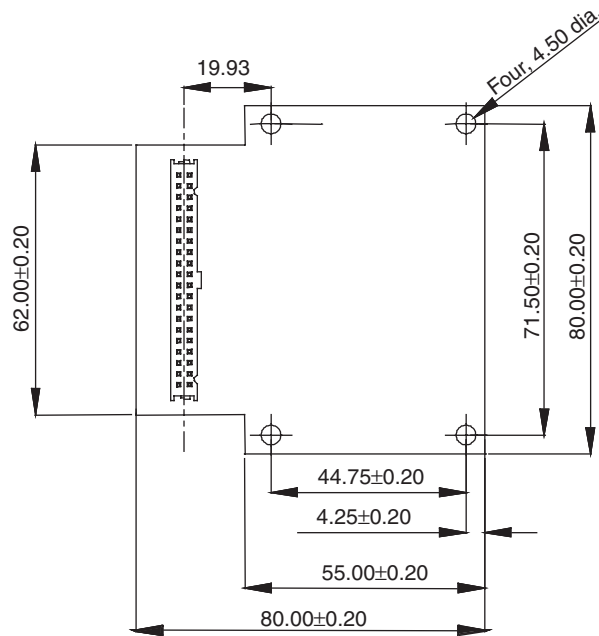

**Mounting**

The DRT2-□D32B/BV is mounted to the control panel using screws. It cannot be mounted to DIN Track. Use M4 mounting screws and mount the board using spacers.

**Mounting Dimensions**

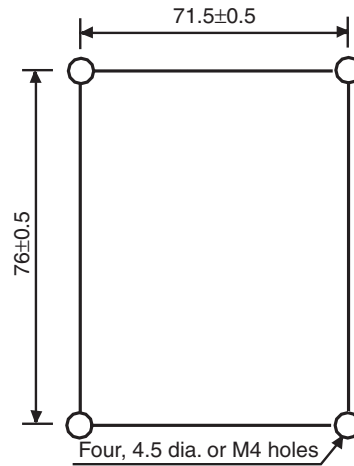

**Mounting Direction**

There are no restrictions to the mounting direction. The board can be mounted in any of the following six directions. The DRT2-□D32BV(-1) is shown in the following diagram.

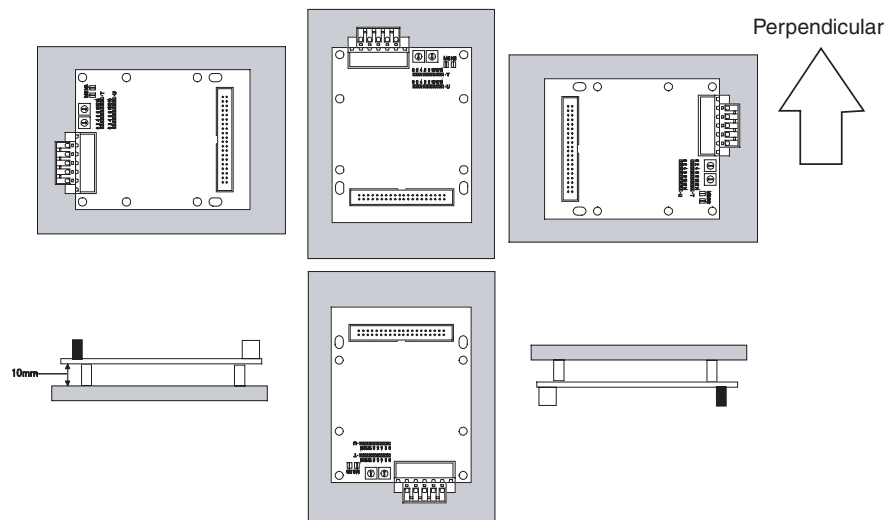

**Wiring Internal Power Supplies, I/O Power Supplies and I/O**

Internal power is supplied together with the communications power supply and does not need to be wired separately. I/O power supplies and I/O are wired through the I/O MIL connector.



**Connecting to I/O Terminals Using OMRON MIL Cables**

The MIL Cables listed in the following table are available to connect OMRON I/O Terminals (e.g., I/O Relay Blocks). Select the MIL Cable that matches the Remote I/O Terminal and the I/O Terminal.

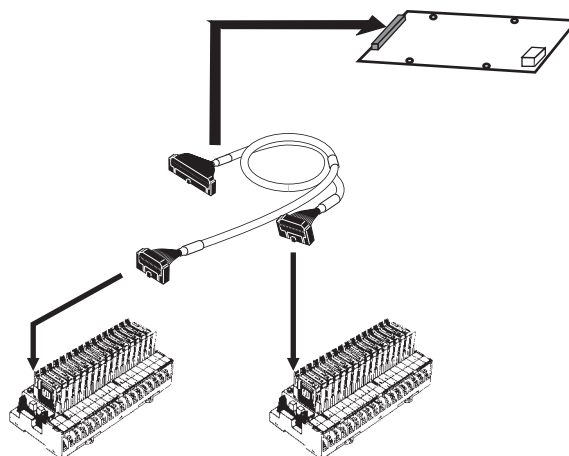

Slave	MIL Cable	I/O Relay Block or other I/O Terminal	Remarks
DRT2-ID32B	G79-I50-25-D1 (50 cm) G79-I75-50-D1 (75 cm)	G7TC-ID16 G7TC-IA16	---
DRT2-OD32B	G79-O50-25-D1 (50 cm) G79-O75-50-D1 (75 cm)	G7TC-OC08/OC16 G70D-SOC16/VSOC16 G70A-ZOC16-3 G70D-FOM16/VFOM16	---
DRT2-MD32B	G79-M50-25-D1 (50 cm) G79-M75-50-D1 (75 cm)	Inputs: G7TC-ID16/IA16 Outputs: G7TC-OC08/OC16 G70D-SOC16/VSOC16 G70A-ZOC16-3	I/O are distinguished by color. Input tube color: Red Output tube color: Yellow
DRT2-ID32B-1	G79-I50-25-D2 (50 cm) G79-I75-50-D2 (75 cm)	G70A-ZIM16-5	---
DRT2-OD32B-1	G79-O50-25-D1 (50 cm) G79-O75-50-D1 (75 cm)	G70A-ZOC16-4 G70D-SOC16-1	---
	G79-I50-25-D1 (50 cm) G79-I75-50-D1 (75 cm)	G7TC-OC16-4 M7F	---
DRT2-MD32B-1	G79-M50-25-D2 (50 cm) G79-M75-50-D2 (75 cm)	Inputs: G70A-ZIM16-5 Outputs: G70A-ZOC16-4 G70D-SOC16-1	I/O are distinguished by color. Input tube color: Red Output tube color: Yellow

The following cables are also available with a MIL connector on the Remote I/O Terminal end and loose wires on the other end.

MIL Cable	Remarks
G79-A200C-D1 (2 m) G79-A500C-D1 (5 m)	Loose wire size: AWG28 Loose wires are cut.
G79-Y100C-D1 (1 m) G79-Y200C-D1 (2 m) G79-Y500C-D1 (5 m)	Forked terminals are attached to the loose wires. Forked terminals: 161071-M2 (Nippon Terminal)

The MIL pin numbers, loose wire colors, dot markings, and dot colors are listed in the following table.

Pin No.	Core color	Dot marking	Dot color	Pin No.	Core color	Dot marking	Dot color
1	Light brown	■	Black	21	Light brown	■ ■ ■	Black
2	brown		Red	22	brown		Red
3	Yellow		Black	23	Yellow		Black
4			Red	24			Red
5	Light green		Black	25	Light green		Black
6			Red	26			Red
7	Gray		Black	27	Gray		Black
8			Red	28			Red
9	White		Black	29	White		Black
10			Red	30			Red
11	Light brown	■ ■	Black	31	Light brown	■ ■ ■ ■	Black
12	brown		Red	32	brown		Red
13	Yellow		Black	33	Yellow		Black
14			Red	34			Red
15	Light green		Black	35	Light green		Black
16			Red	36			Red
17	Gray		Black	37	Gray		Black
18			Red	38			Red
19	White		Black	39	White		Black
20			Red	40			Red

**Using Pressure-welded Flat Cable Connectors**

Use the following procedure to prepare flat cables with XG4M-4030-T MIL Connectors.

- 1,2,3...
1. Use precision screwdrivers to open the hooks on both ends and separate the contacts from the cover of the MIL socket. There are two tabs on each end of the contact side of the socket. Release both of these at the same time, not one at a time.

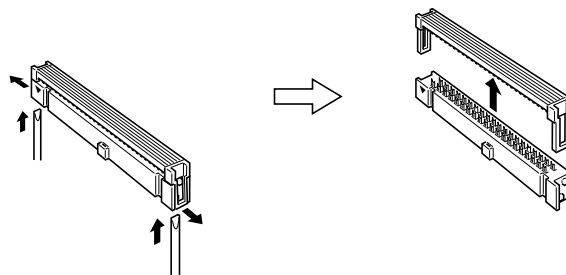

2. Place the flat cable between the contacts and cover of the socket, align the contacts, and press on the cover to lock it in place on the contacts. Use a vise or similar device to firmly press the cover on until the tabs are properly joined.

Applicable Wires: 1.27-mm pitch flat cable, AWG28 (7-strand wire)

UL2651: Standard Cable, UL20012: Stranded Cable, UL20028: Color Coded Cable

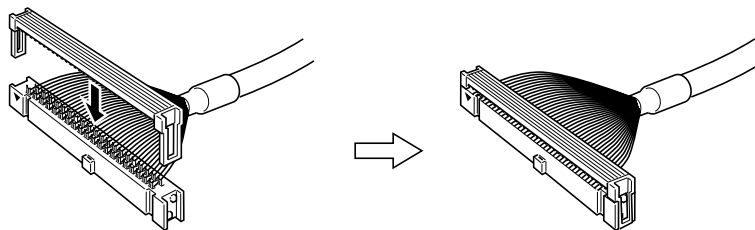

3. If required, fold the back over the connector, and insert and lock a strain relief in place.

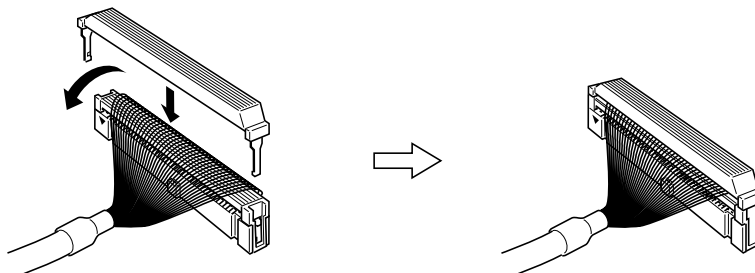

4. Connect the MIL Connector to a Remote I/O Terminal with a Connector.

### Using Loose Wires with Pressure-welded Connectors

Use the following parts to prepare cables. The Socket used depends on the wire size.

Part	Cable wire size: AWG24	Cable wire size: AWG26 to 26
Socket	XG5M-4032-N	XG5M-4035-N
Semi-cover (See note 1.)	XG5S-2001	
Hood Cover (See note 2.)	XG5S-5022	

- Note**
1. Two Semi-covers are required for each connector.
  2. A multi-drop DeviceNet Connector cannot be used if the Hood Cover is used.

Refer to the *PCB Relays Catalog* (Cat. No. X33) for details on the XG5 Loose Wire Pressure-welded Connectors.

## 5-7 Screw-less Clamp Terminals

The Screw-less Clamp Terminal has a structure designed for clamping to a terminal block. It is a reduced-wiring, labor-saving Slave that can make wiring easy by simply inserting post terminals (sleeves). The Unit and terminal block can be detached, making it possible to replace the Unit in the event of a failure without removing the wiring.

There are two categories of Screw-less Clamp Terminals: Those that have detection functions for early detection of errors, and those that do not.

### Models without Detection Functions

Model	Specifications
DRT2-ID16SL(-1)	16 inputs
DRT2-ID32SL(-1)	32 inputs
DRT2-MD32SL(-1)	16 inputs/16 outputs
DRT2-OD16SL(-1)	16 outputs
DRT2-OD32SL(-1)	32 outputs

### Models With Detection Functions

Model	Specifications
DRT2-ID16SLH(-1)	16 inputs
DRT2-ID32SLH(-1)	32 inputs
DRT2-MD32SLH(-1)	16 inputs/16 outputs
DRT2-OD16SLH(-1)	16 outputs
DRT2-OD32SLH(-1)	32 outputs

### 5-7-1 Node Address, Baud Rate, and Output Hold/Clear Settings

These settings are made in the same way as for Remote I/O Terminals (Transistor Type). Refer to 5-5-1 Node Address, Baud Rate, and Output Hold/Clear Settings.

### 5-7-2 Wiring to a Screw-less Clamp Terminal Block

Screw-less Clamp Terminals provide clamp-type terminal blocks that allow wiring without screws. When connecting a sensor or an external device, a special post terminal must be attached to the cable for the sensor or device.

Manufacturer	Model	
PHOENIX CONTACT	AI-0.5-10	0.5 mm <sup>2</sup> (AWG 20)
	AI-0.75-10	0.75 mm <sup>2</sup> (AWG 18)
	AI-1.5-10	1.25 mm <sup>2</sup> (AWG 16)
Nihon Weidmuller	H 0.5/16 D	0.5 mm <sup>2</sup> (AWG 20)
	H 0.75/16 D	0.75 mm <sup>2</sup> (AWG 18)
	H 1.5/16 D	1.25 mm <sup>2</sup> (AWG 16)

### Power Supply Wiring

Two cables are provided with the DRT2-□D32SL(-1) and DRT2-□D32SLH(-1) Terminals for V and G, to transfer power between terminal blocks. Use these cables when there is no need to divide the power by block. The rated current is 10 A max.

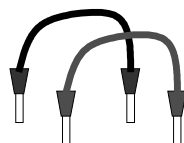

**Wiring to a Clamp Terminal Block**

**Insertion**

Insert the post terminal all the way to the end in any terminal hole.

**Removal**

Pull out the power line while pressing down with a small flat-blade screwdriver on the release button above the terminal hole.

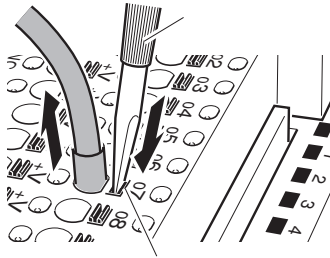

The following screwdriver is recommended for use when removing cables.

**Recommended Screwdriver Model**

Model	Manufacturer
SZF1	PHOENIX CONTACT

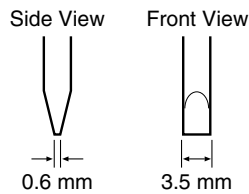

**Removing and Mounting a Clamp Terminal Block**

**Removal**

Use a flat-blade screwdriver to loosen the four screws on the top of the terminal block, and then grasp the handles on both sides and remove the terminal block.

**Mounting**

Grasp the handles on both sides of the terminal block, and insert the terminal block firmly in place. Then use a flat-blade screwdriver to tighten the four screws on the top of the terminal block.

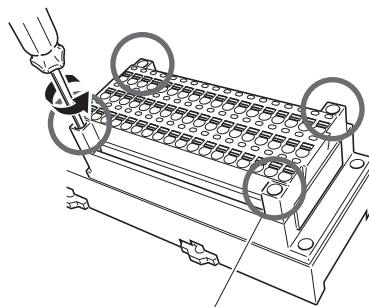

Four 2.6x6 standard screws

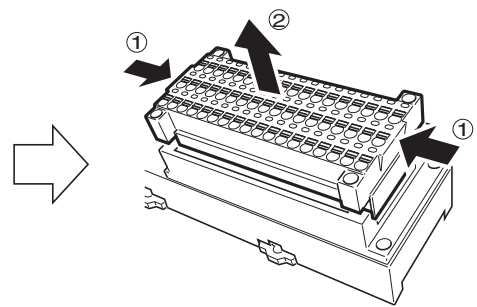







- ① Grasp handles on both sides.
- ② Pull out the terminal block.

**Note** Tighten the screws to a torque of 0.2 to 0.25 N·m.

### 5-7-3 I/O Indicators

The I/O indicators show the ON/OFF status of inputs and outputs and the error status of connected devices.

Indicator name	Status	Color	Meaning (main error)
0 to 15 (Display for each contact)		Yellow	Lit when input or output is ON.
		Red	Lit when error is detected. Output: External load disconnection Input: Sensor disconnection Clear as follows: Output: For manual recovery, clear error and then restart. For automatic recovery, clear error. Input: Clear error.
		Red	Lit when error is detected. Output: External load short-circuit (for DRT2-OD16SLH(-1) only) Input: Sensor power supply short-circuit Clear as follows: Output: For manual recovery, clear error and then restart. For automatic recovery, clear error. Input: Clear error.
		OFF	Lit when input or output is OFF.
I/O		Green	I/O power is being supplied.
		OFF	I/O power is not being supplied.

### 5-7-4 Screw-less Clamp Terminals with 16 Transistor Inputs

#### Input Specifications

Item	Specification			
	DRT2-ID16SL	DRT2-ID16SL-1	DRT2-ID16SLH	DRT2-ID16SLH-1
Model	DRT2-ID16SL	DRT2-ID16SL-1	DRT2-ID16SLH	DRT2-ID16SLH-1
Internal I/O common	NPN	PNP	NPN	PNP
Input points	16 points			
I/O power supply voltage	20.4 to 26.4 V DC (24 V DC, -15% to 10%)			
Input current	6.0 mA max./point at 24 V DC, 3.0 mA min./point at 17 V DC			
Input resistance	4 kΩ			
ON delay time	1.5 ms max.			
OFF delay time	1.5 ms max.			
ON voltage	15 V DC min. (between each input terminal and V)	15 V DC min. (between each input terminal and G)	15 V DC min. (between each input terminal and V)	15 V DC min. (between each input terminal and G)
OFF voltage	5 V DC max. (between each input terminal and V)	5 V DC max. (between each input terminal and G)	5 V DC max. (between each input terminal and V)	5 V DC max. (between each input terminal and G)
ON current	3 mA min.			
OFF current	1 mA max.			
Number of circuits	8 points with one common			
Power supply short-circuit protection	---		Operates at 50 mA/pt. min.	

Item	Specification	
Disconnection detection	---	Operates at 0.3 mA/pt. max.
Current supplied to input devices	100 mA/input	50 mA/input

**Component Names and Functions (Same for DRT2-ID16SL(-1) and DRT2-ID16SLH(-1))**

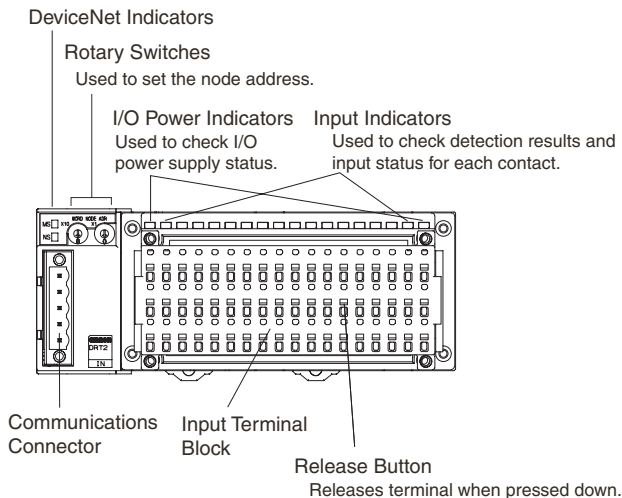

**Internal Circuits**

**DRT2-ID16SL (NPN)**

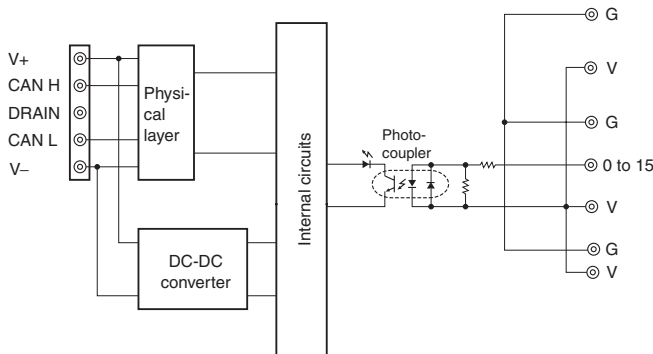

**DRT2-ID16SL-1 (PNP)**

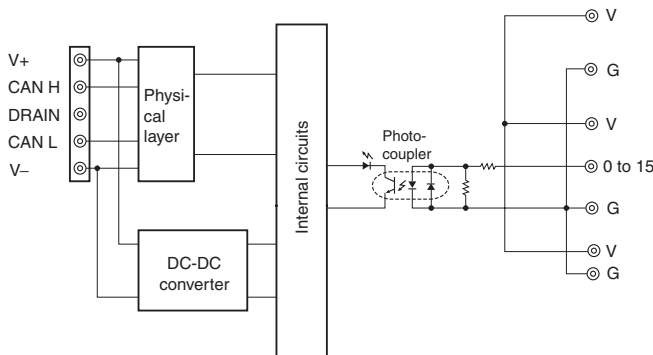

**DRT2-ID16SLH (NPN)**

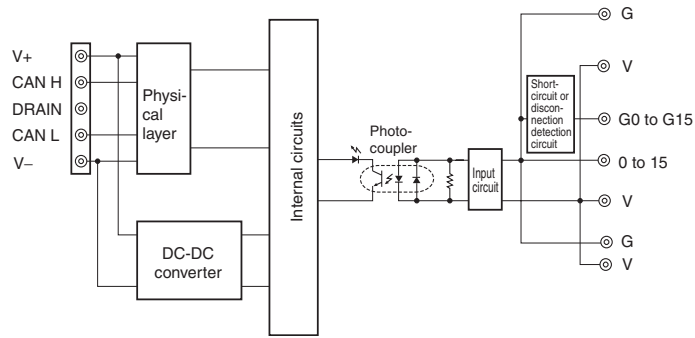

**DRT2-ID16SLH-1 (PNP)**

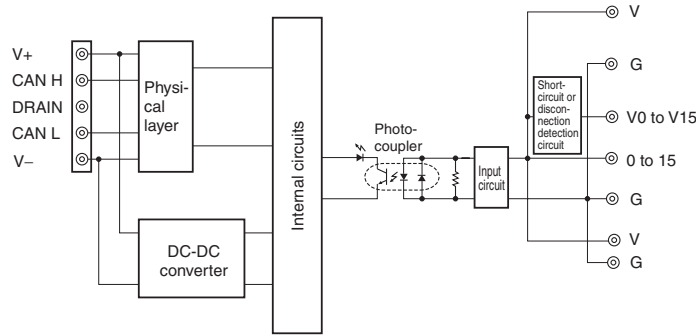

**Wiring**

**DRT2-ID16SL (NPN)**

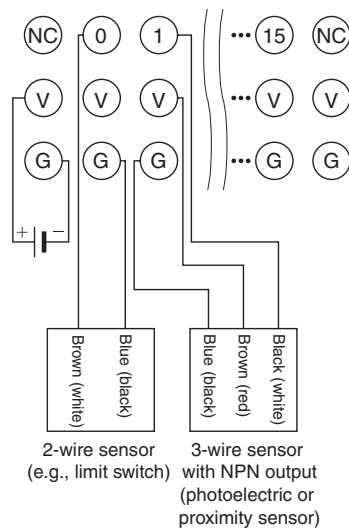



**DRT2-ID16SL-1 (PNP)**

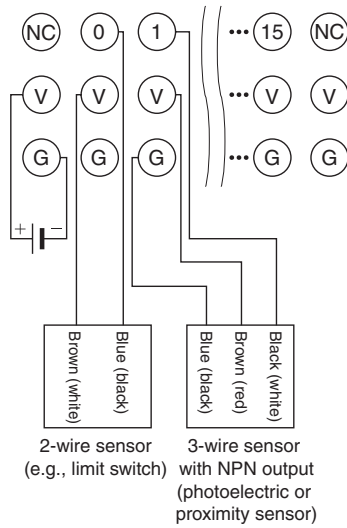

**DRT2-ID16SLH (NPN)**

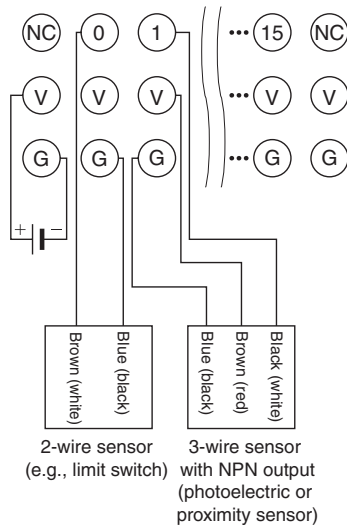

**DRT2-ID16SLH-1 (PNP)**

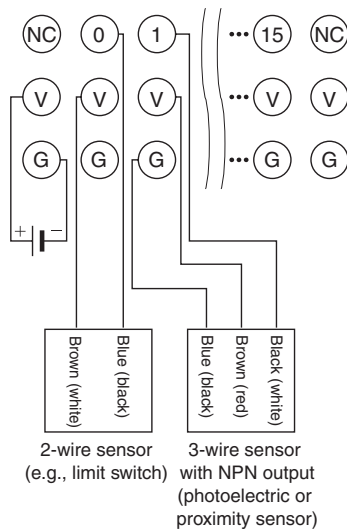

**Note** Wire colors have been changed according to revisions in the JIS standards for photoelectric and proximity sensors. The colors in parentheses are the wire colors prior to the revisions.

**Dimensions (Same for DRT2-ID16SL(-1) and ID16SLH(-1))**

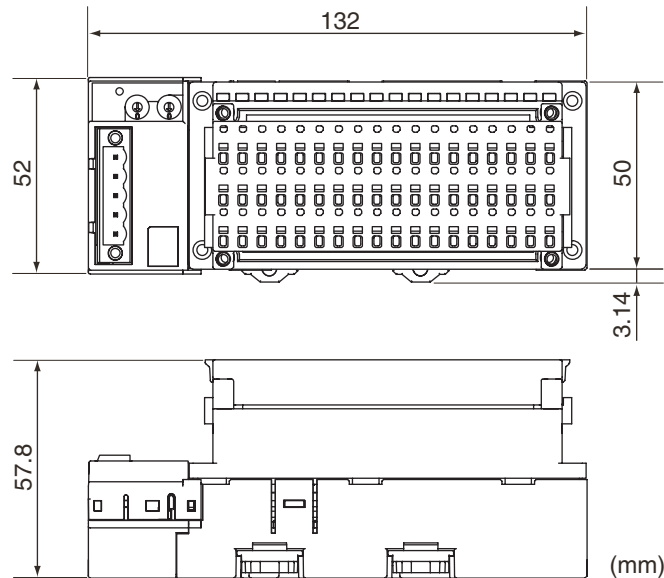

**5-7-5 Screw-less Clamp Terminals with 32 Transistor Inputs**

**Input Specifications**

Item	Specification			
	DRT2-ID32SL	DRT2-ID32SL-1	DRT2-ID32SLH	DRT2-ID32SLH-1
Model	DRT2-ID32SL	DRT2-ID32SL-1	DRT2-ID32SLH	DRT2-ID32SLH-1
Internal I/O common	NPN	PNP	NPN	PNP
Input points	32 points			
I/O power supply voltage	20.4 to 26.4 V DC (24 V DC, -15% to 10%)			
Input current	6.0 mA max./point at 24 V DC, 3.0 mA min./point at 17 V DC			
Input resistance	4 k $\Omega$			
ON delay time	1.5 ms max.			
OFF delay time	1.5 ms max.			
ON voltage	15 V DC min. (between each input terminal and V)	15 V DC min. (between each input terminal and G)	15 V DC min. (between each input terminal and V)	15 V DC min. (between each input terminal and G)
OFF voltage	5 V DC max. (between each input terminal and V)	5 V DC max. (between each input terminal and G)	5 V DC max. (between each input terminal and V)	5 V DC max. (between each input terminal and G)
ON current	3 mA min.			
OFF current	1 mA max.			
Number of circuits	16 points with one common			
Power supply short-circuit protection	---		Operates at 50 mA/pt. min.	
Disconnection detection	---		Operates at 0.3 mA/pt. max.	

**Component Names and Functions (Same for DRT2-ID32SL(-1) and DRT2-ID32SLH(-1))**

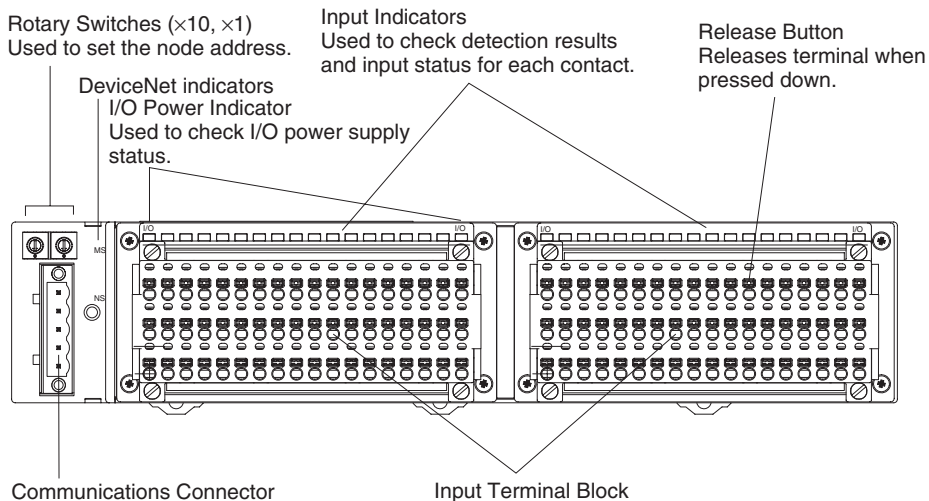

**Internal Circuits**

**DRT2-ID32SL**

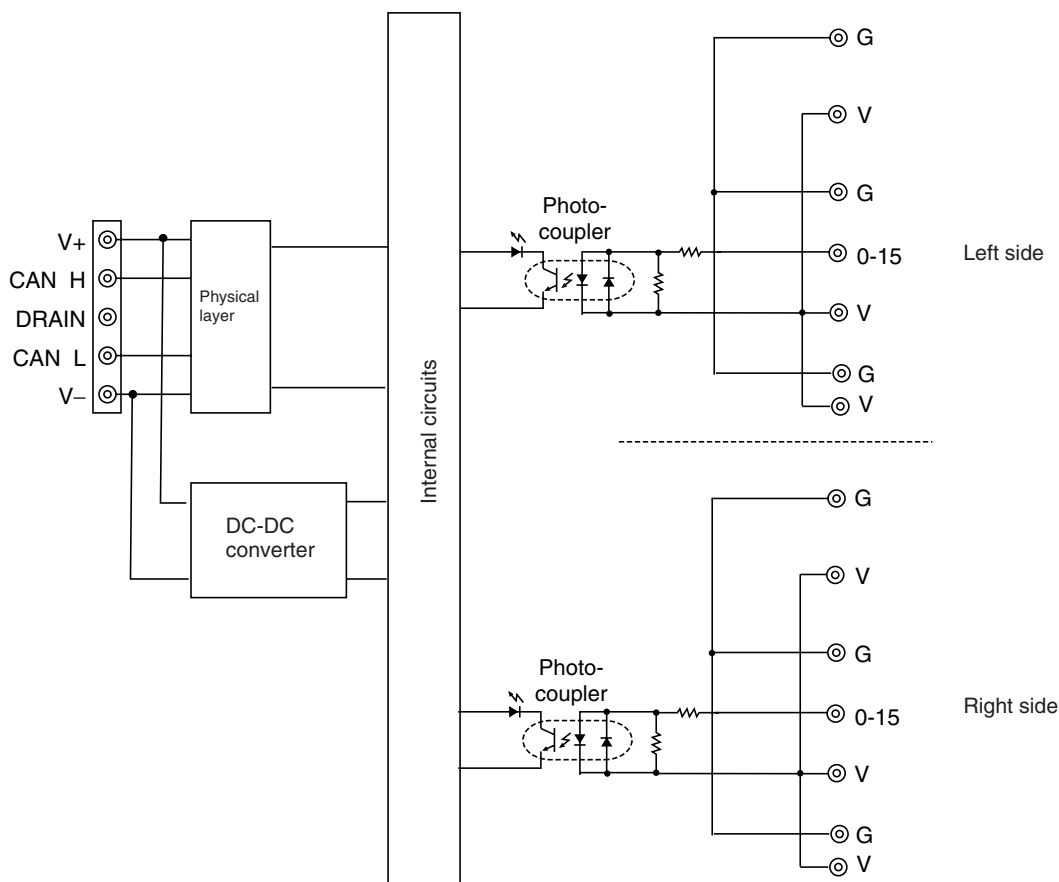

DRT2-ID32SL-1

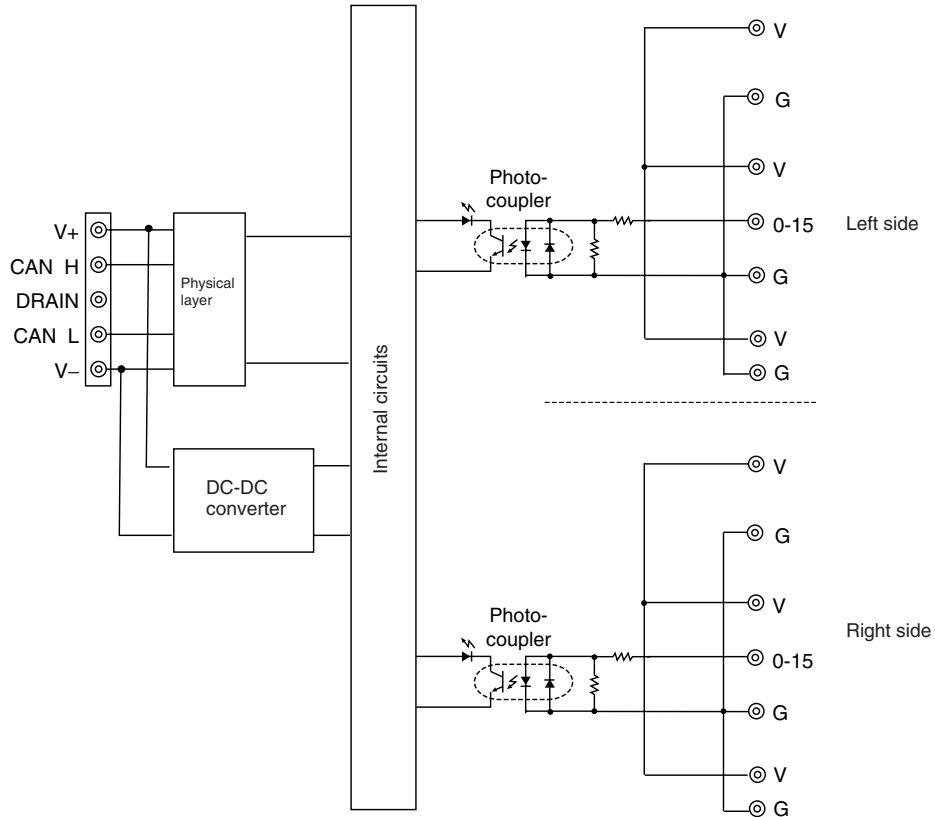

DRT2-ID32SLH

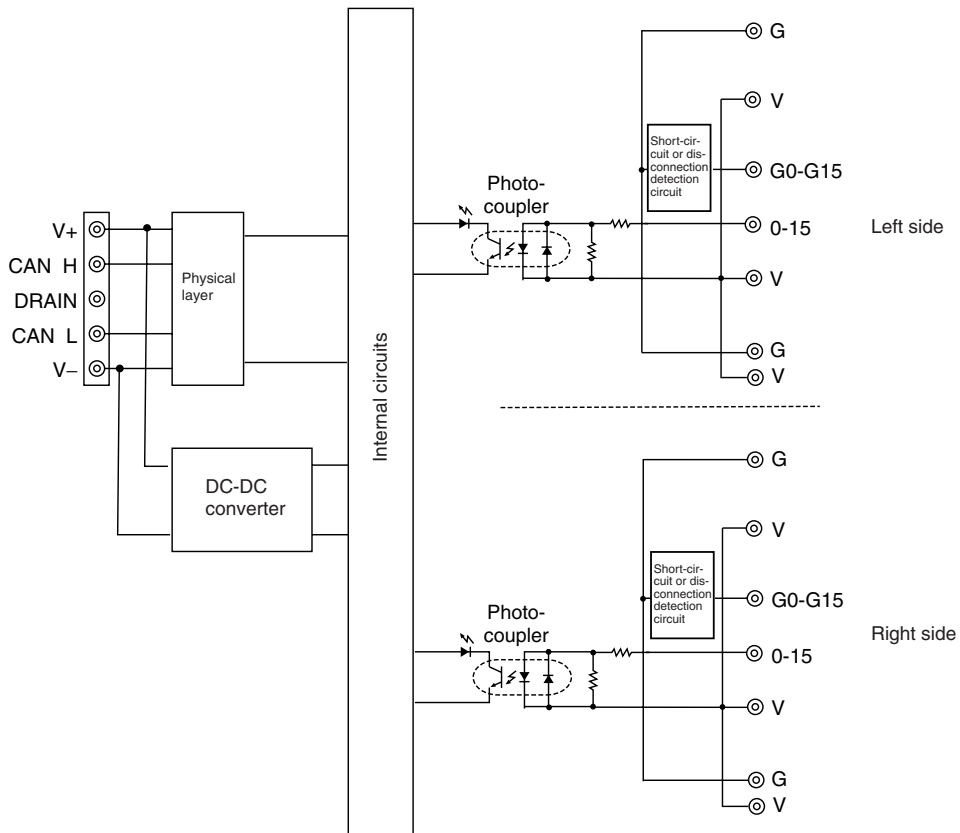

DRT2-ID32SLH-1

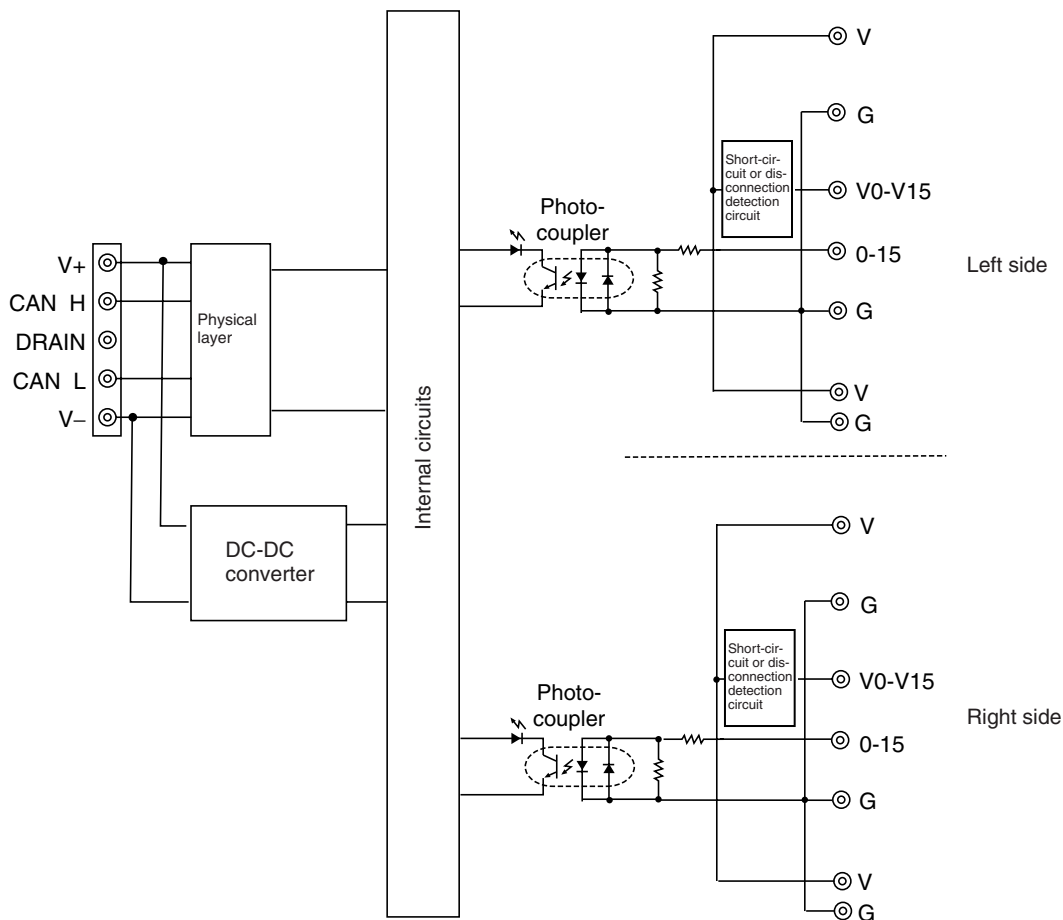

Wiring

DRT2-ID32SL (NPN)

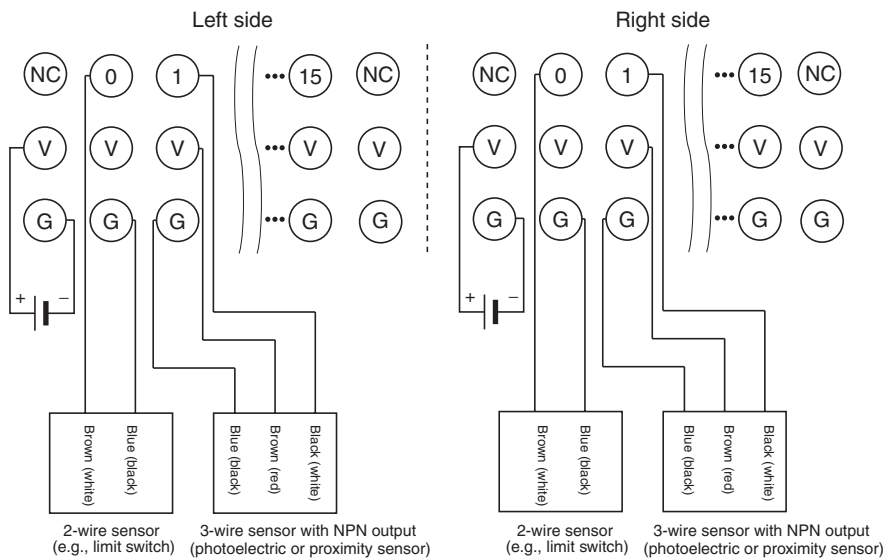

**DRT2-ID32SL-1 (PNP)**

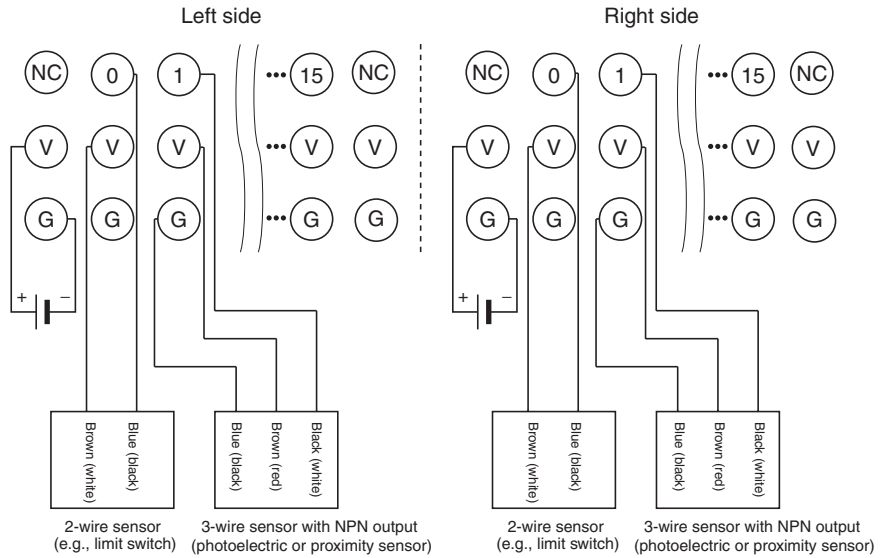

**DRT2-ID32SLH (NPN)**

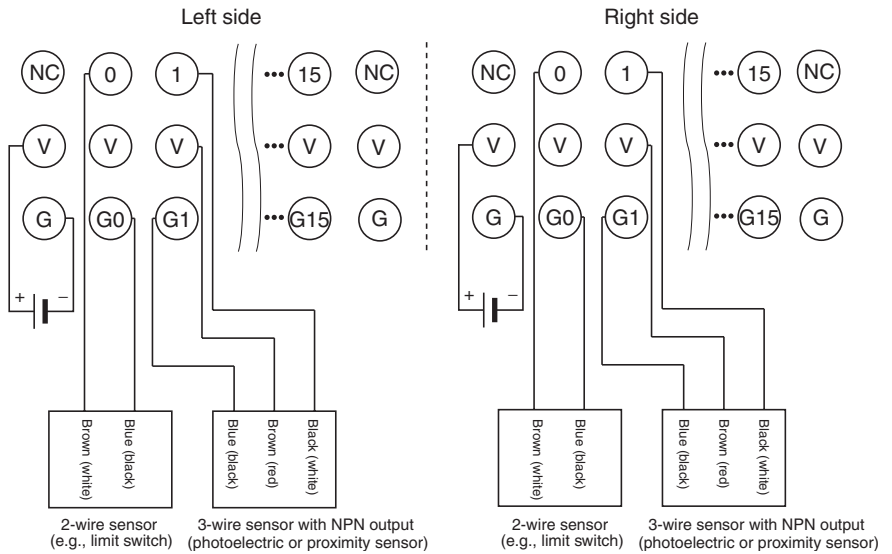

**DRT2-ID32SLH-1 (PNP)**

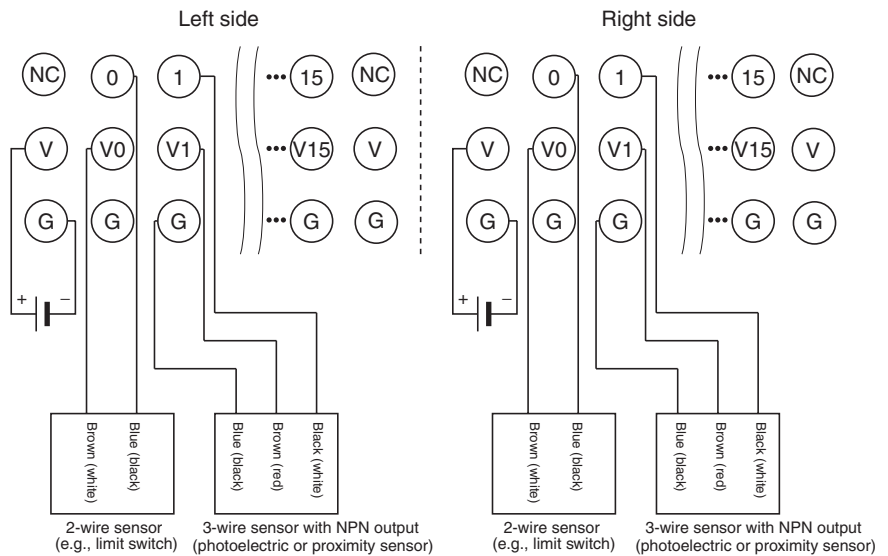

- Note**
1. The I/O power supply's right-side and left-side V terminals, and the right-side and left-side G terminals, are not connected internally. Supply power separately between V and G on the right and left sides respectively.
  2. Wire colors have been changed according to revisions in the JIS standards for photoelectric and proximity sensors. The colors in parentheses are the wire colors prior to the revisions.

**Dimensions (Same for DRT2-ID32SL(-1) and DRT2-ID32SLH(-1))**

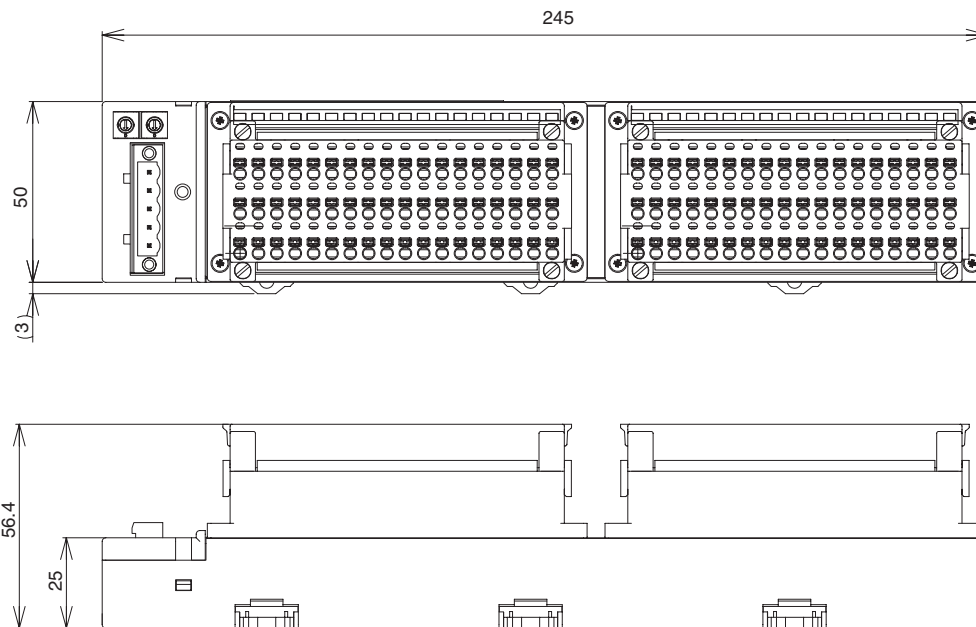

**5-7-6 Screw-less Clamp Terminals with and 16 Transistor Outputs**

**Output Specifications**

Item	Specification			
Model	DRT2-OD16SL	DRT2-OD16SL-1	DRT2-OD16SLH	DRT2-OD16SLH-1
Internal I/O common	NPN	PNP	NPN	PNP
Output points	16 points			
I/O power supply voltage	20.4 to 26.4 V DC (24 V DC, -15% to 10%)			
Output current	0.5 A/point, 4.0 A/common			
Residual voltage	1.2 V max.			
Leakage current	0.1 mA max.			
ON delay time	0.5 ms max.			
OFF delay time	1.5 ms max.			
Disconnection detection	---		Operates at current consumption of 3 mA/point max. (Not detected at 3 mA or less.)	
Current supplied to output devices	100 mA/output			
Output when error detected	According to hold/clear setting when error is detected. (The factory setting is for clear.)			

**Component Names and Functions**  
 (Same for DRT2-OD16SL(-1) and DRT2-OD16SLH(-1))

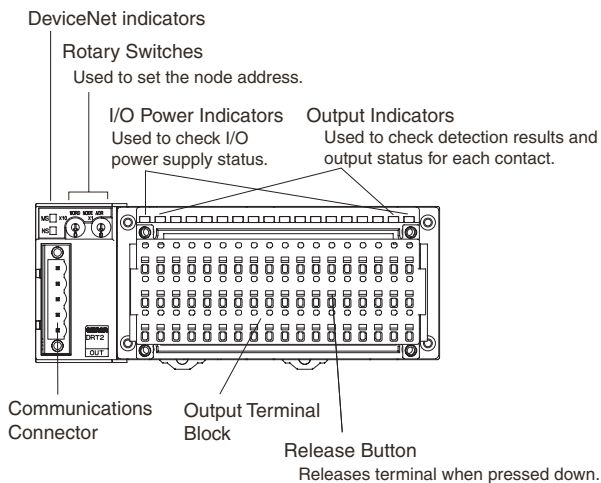

**Internal Circuits**

**DRT2-OD16SL (NPN)**

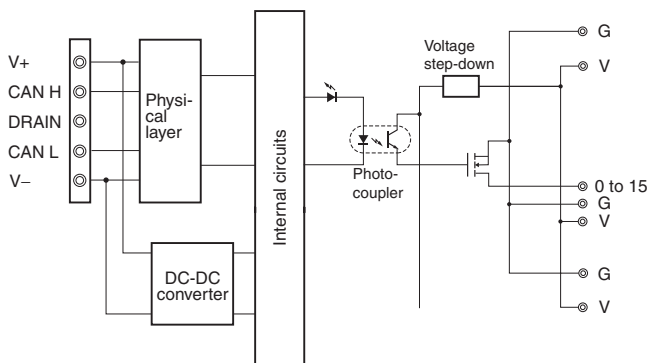

**DRT2-OD16SL-1 (PNP)**

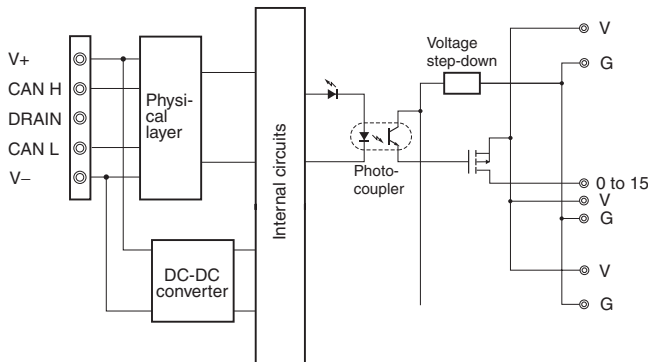



**DRT2-OD16SLH (NPN)**

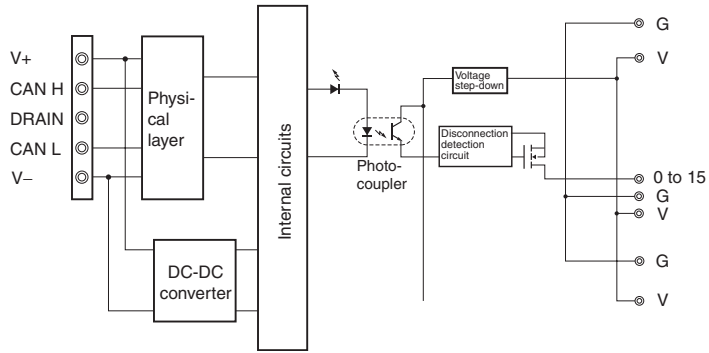

**DRT2-OD16SLH-1 (PNP)**

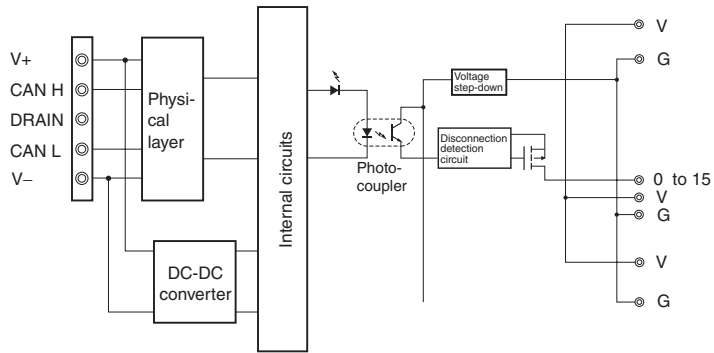

**Wiring**

**DRT2-OD16SL (NPN)**

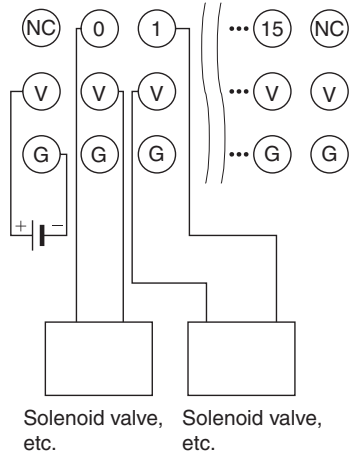

DRT2-OD16SL-1 (PNP)

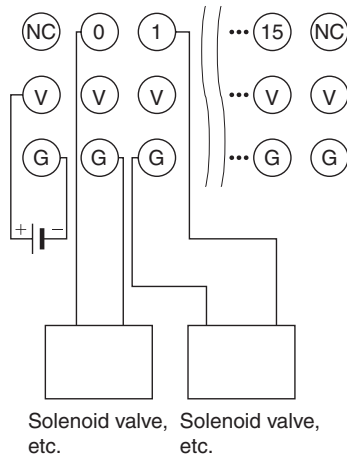

DRT2-OD16SLH (NPN)

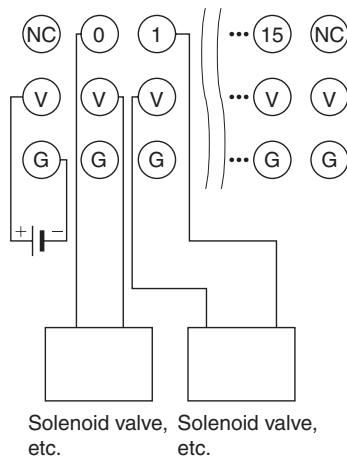

DRT2-OD16SLH-1 (PNP)

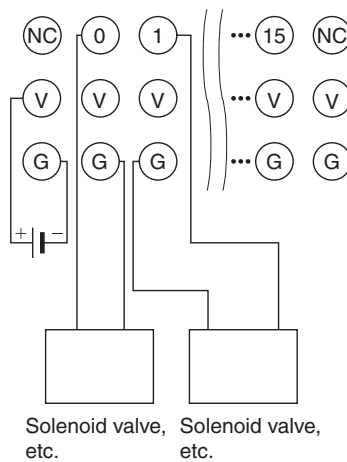

**Note** When using inductive loads (such as solenoid valves), use a load with a built-in diode to absorb reverse power or attach a diode externally.

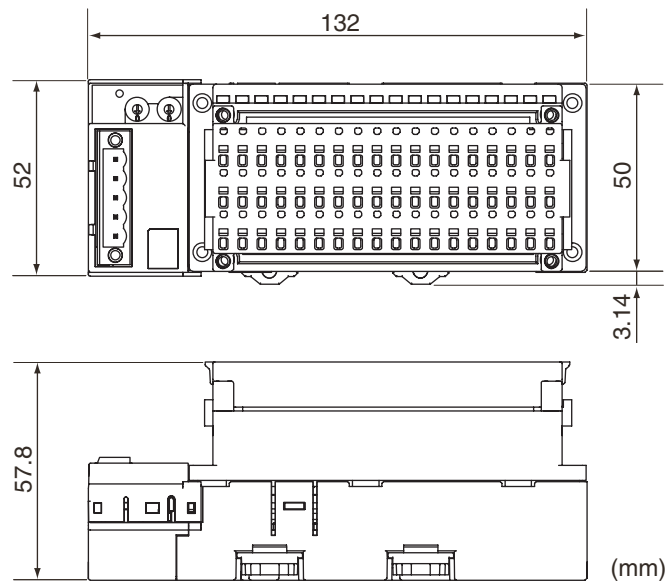
**Dimensions (Same for DRT2-OD16SL(-1) and DRT2-OD16SLH(-1))****Load Short-circuit Protection: DRT2-OD16SLH and DRT2-OD16SLH-1**

Normally, when the output contact (OUT) turns ON, the transistor turns ON, and output current ( $I_{out}$ ) flows, as shown in Fig. 1.

If the current limit ( $I_{lim}$ ) is exceeded when there is an overload in the output current ( $I_{out}$ ) or when a load short-circuit occurs, as shown in Fig. 2 and 3, the output current ( $I_{out}$ ) will be limited. Then, if the output transistor junction temperature ( $T_j$ ) reaches the thermal shutdown temperature ( $T_{std}$ ), the output will be turned OFF to prevent damage to the transistor, the Load Shorted Flag will be turned ON, and the indicator will light red.

In automatic recovery mode (Fig. 2), the short-circuit protection status will be automatically cleared and the output current will start to flow again when the transistor's shutdown temperature ( $T_j$ ) drops to the reset temperature ( $T_r$ ).

In manual recovery mode (Fig. 3), the short-circuit protection status will be held even when the transistor's shutdown temperature ( $T_j$ ) drops to the reset temperature ( $T_r$ ), and recovery will occur when the Unit is reset by turning OFF the I/O power supply or the Unit's power supply.

**Fig. 1 Normal Operation**

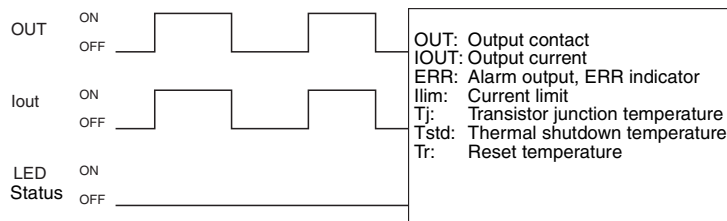

**Fig. 2 Overload or Short-circuit (Automatic Recovery Mode)**

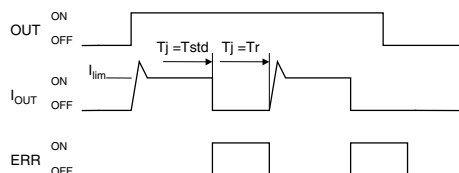

**Fig. 3 Overload or Short-circuit (Manual Recovery Mode)**

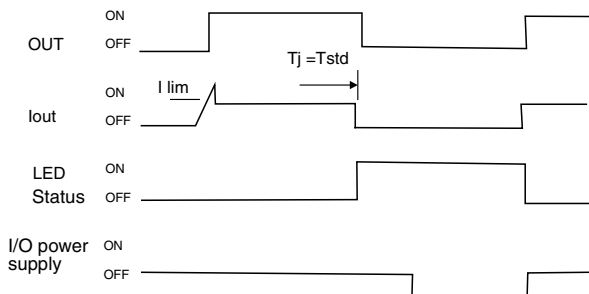

**Automatic Recovery Mode Restrictions**

The Unit has load short-circuit protection, but automatic recovery mode is designed to protect the internal circuits specifically from a brief load short-circuit.

In automatic recovery mode, the Unit's load short-circuit protection is automatically cleared when  $T_j = T_r$ , as shown in Fig. 2. Therefore, as long as the cause of the short-circuit is not removed, the output's ON/OFF operation will repeat.

If the Unit is left with a short circuit, the internal temperature will rise, causing damage to the Unit. Always remove the cause of an external load short-circuit promptly.

**Note** When an external load short-circuit is detected, the External Load Shorted Flag will turn ON in the Unit's Status Area and the indicator corresponding to the shorted output contact will turn ON. An OR for all contact status will output to the Short-circuited Flag.

When the Load Shorted Flag turns ON, either hold the status of the bit in the user program and program to turn OFF all the Unit's outputs, or use an Explicit message to read the contact that is shorted and turn it OFF. The Short-circuited Flag is allocated in the fifth bit in the Unit's status information area.



### 5-7-7 Screw-less Clamp Terminals with and 32 Transistor Outputs

#### Output Specifications

Item	Specification			
	DRT2-OD32SL	DRT2-OD32SL-1	DRT2-OD32SLH	DRT2-OD32SLH-1
Model	DRT2-OD32SL	DRT2-OD32SL-1	DRT2-OD32SLH	DRT2-OD32SLH-1
Internal I/O common	NPN	PNP	NPN	PNP
Output points	32 points			
I/O power supply voltage	20.4 to 26.4 V DC (24 V DC, -15% to 10%)			
Output current	0.5 A/point, 4.0 A/common			
Residual voltage	1.2 V max.			
Leakage current	0.1 mA max.			
ON delay time	0.5 ms max.			
OFF delay time	1.5 ms max.			
Disconnection detection	---		Operates at current consumption of 3 mA/point max. (Not detected at 3 mA or less.)	
Output when error detected	According to hold/clear setting when error is detected. (The factory setting is for clear.)			

#### Component Names and Functions

(Same for DRT2-OD32SL(-1) and DRT2-OD32SLH(-1))

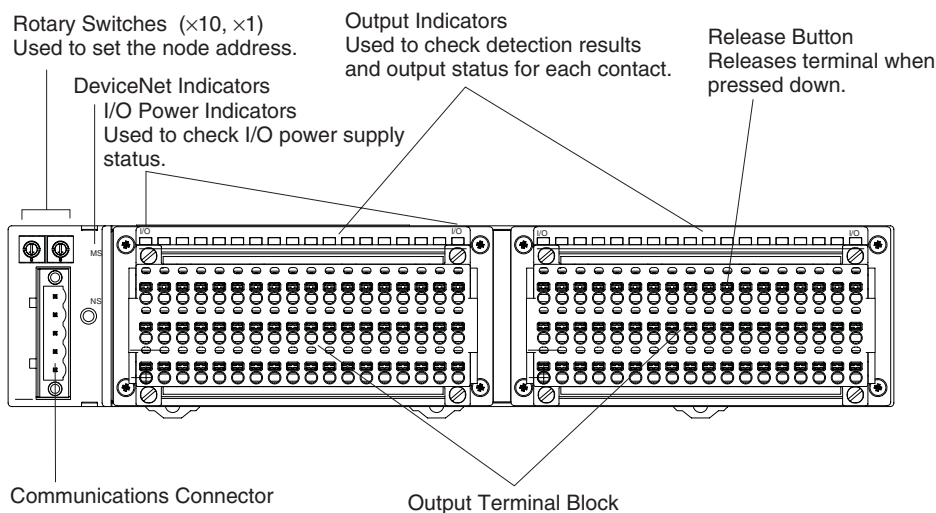

**Internal Circuits**

**DRT2-OD32SL (NPN)**

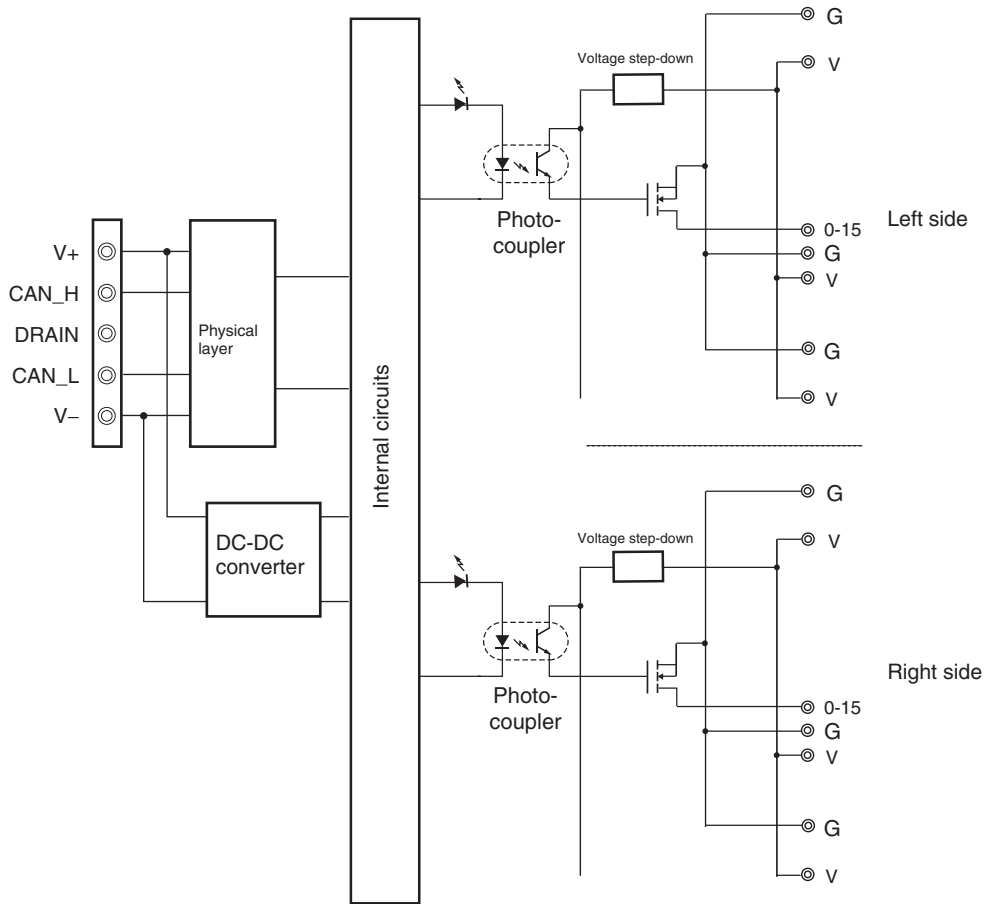

DRT2-OD32SL-1 (PNP)

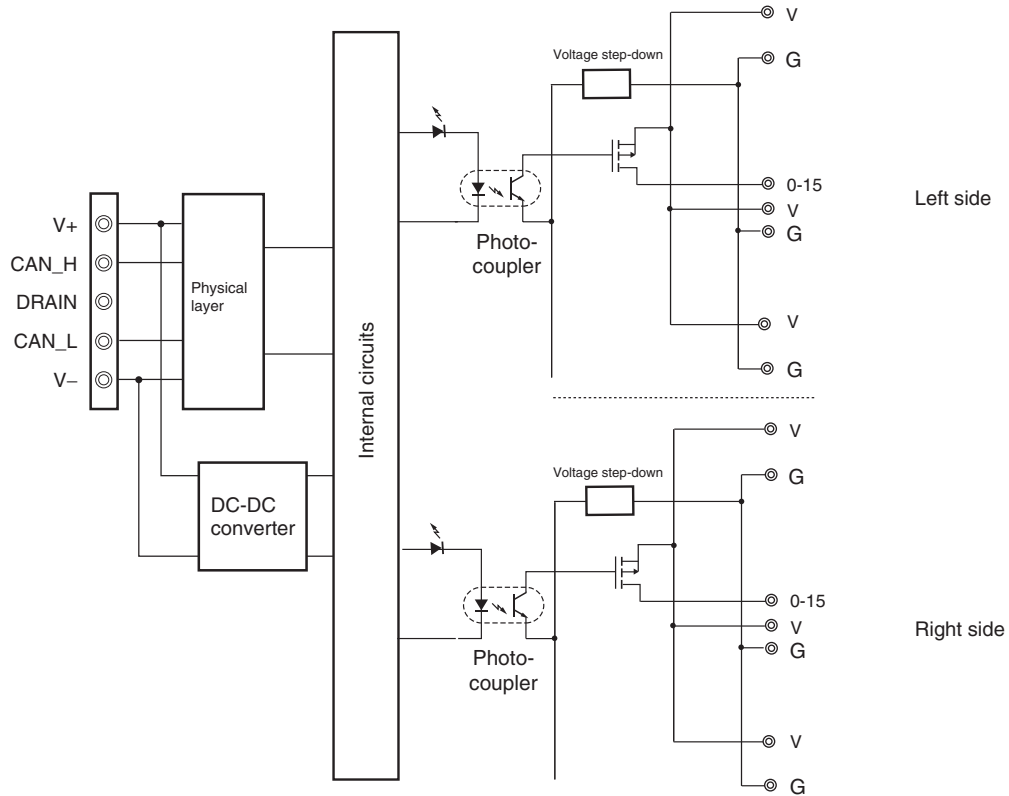

DRT2-OD32SLH (NPN)

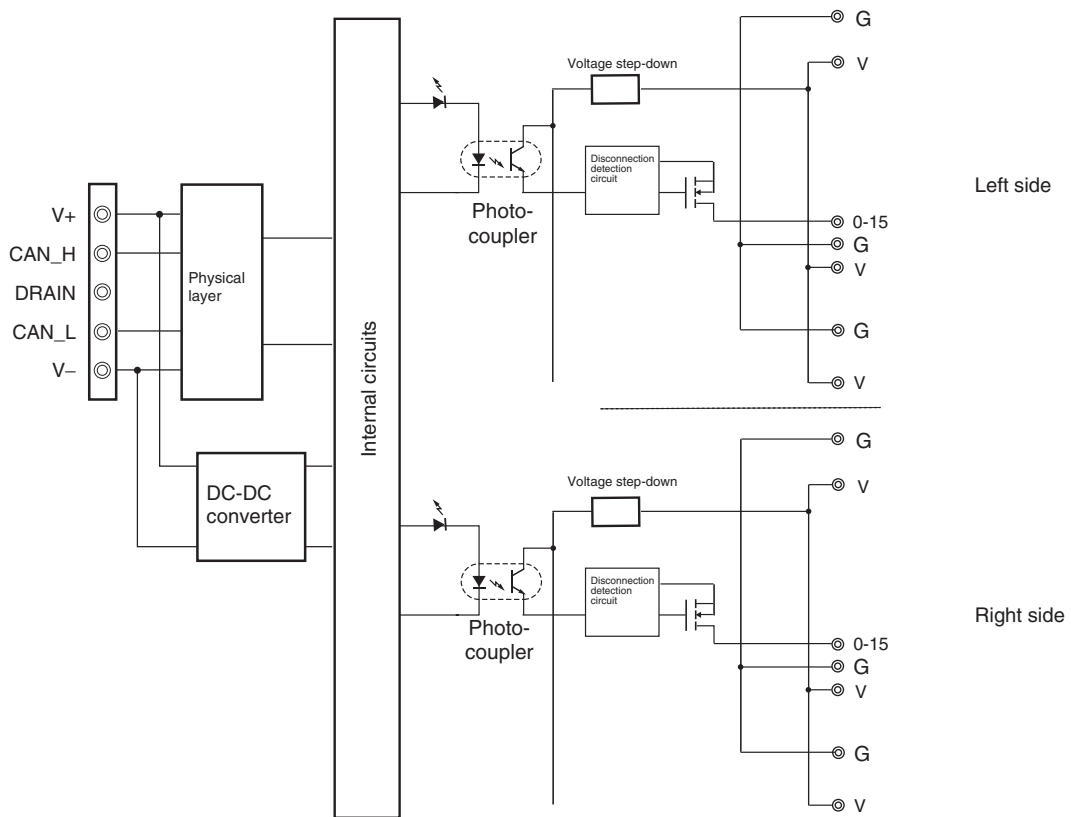

DRT2-OD32SLH-1 (PNP)

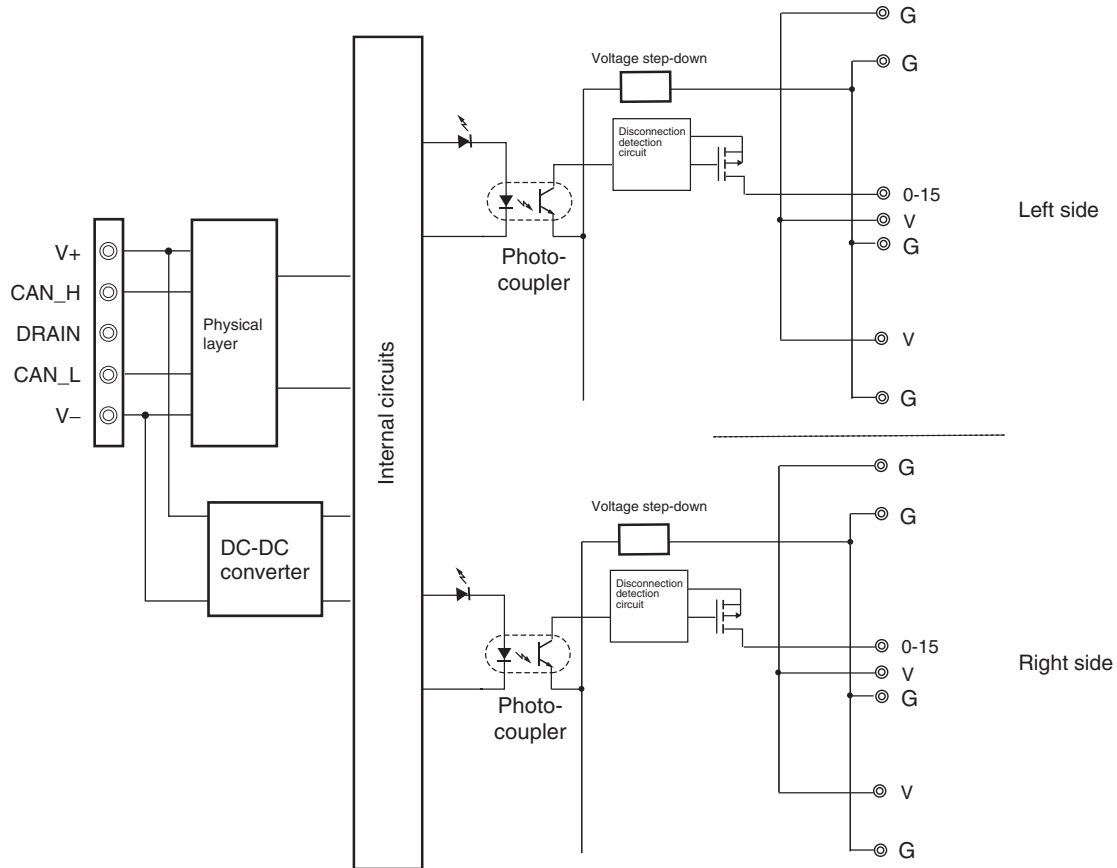

**Wiring**

DRT2-OD32SL (NPN)

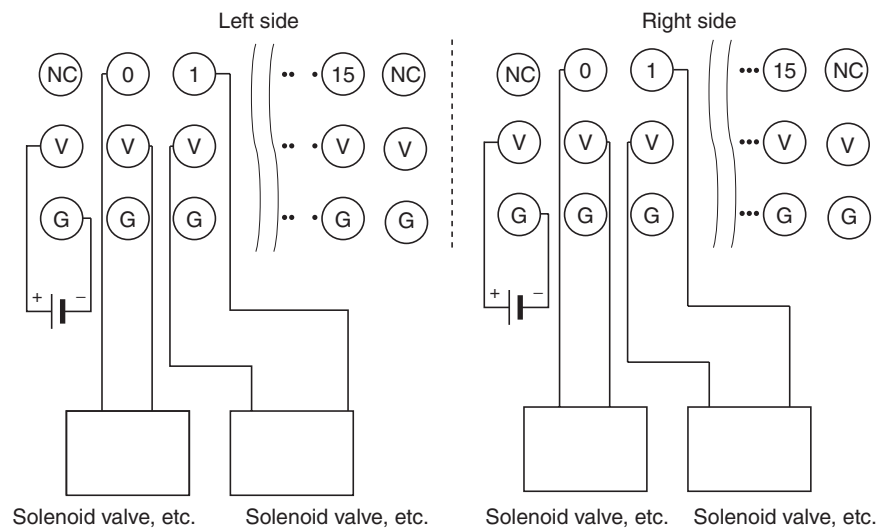



**DRT2-OD32SL-1 (PNP)**

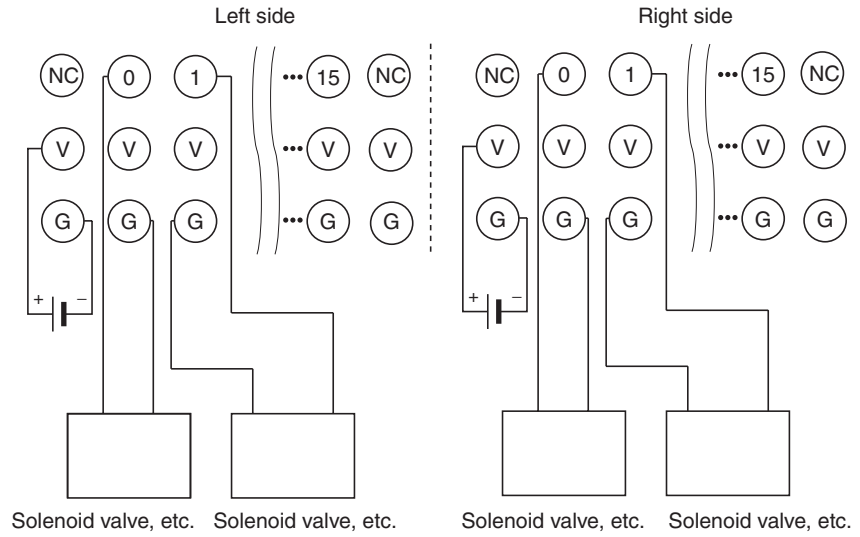

**DRT2-OD32SLH (NPN)**

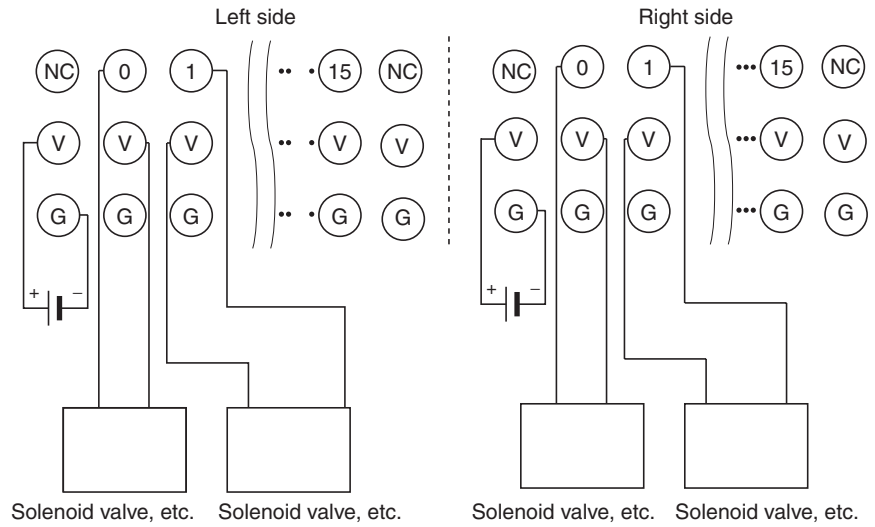

**DRT2-OD32SLH-1 (PNP)**

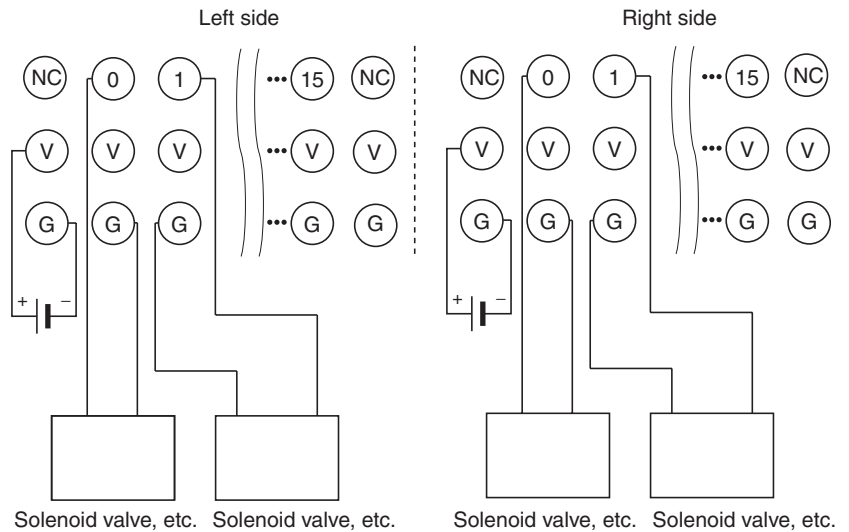

- Note**
1. The I/O power supply's right-side and left-side V terminals, and the right-side and left-side G terminals, are not connected internally. Supply power separately between V and G on the right and left sides respectively.
  2. When using inductive loads (such as solenoid valves), use a load with a built-in diode to absorb reverse power or attach a diode externally.

### Dimensions (DRT2-OD32SL-1 and DRT2-OD32SLH-1)

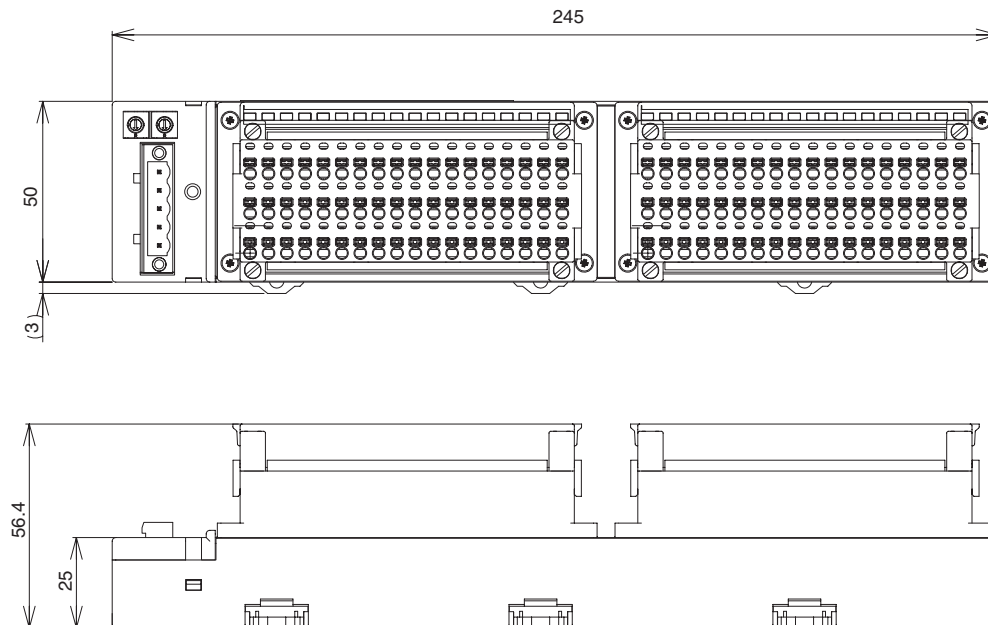

## 5-7-8 Screw-less Clamp Terminals with 16 Transistor Inputs and Outputs

### Input Specifications

Item	Specification			
Model	DRT2-MD32SL	DRT2-MD32SL-1	DRT2-MD32SLH	DRT2-MD32SLH-1
Internal I/O common	NPN	PNP	NPN	PNP
Input points	16 points			
I/O power supply voltage	20.4 to 26.4 V DC (24 V DC, -15% to 10%)			
Input current	6.0 mA max./point at 24 V DC, 3.0 mA min./point at 17 V DC			
Input resistance	4 k $\Omega$			
ON delay time	1.5 ms max.			
OFF delay time	1.5 ms max.			
ON voltage	15 V DC min. (between each input terminal and V)	15 V DC min. (between each input terminal and G)	15 V DC min. (between each input terminal and V)	15 V DC min. (between each input terminal and G)
OFF voltage	5 V DC max. (between each input terminal and V)	5 V DC max. (between each input terminal and G)	5 V DC max. (between each input terminal and V)	5 V DC max. (between each input terminal and G)
ON current	3 mA min.			
OFF current	1 mA max.			
Number of circuits	16 points with one common			
Power supply short-circuit protection	---		Operates at 50 mA/point min.	
Disconnection detection	---		Operates at 0.3 mA max.	

**Output Specifications**

Item	Specification			
	DRT2-MD32SL	DRT2-MD32SL-1	DRT2-MD32SLH	DRT2-MD32SLH-1
Model	DRT2-MD32SL	DRT2-MD32SL-1	DRT2-MD32SLH	DRT2-MD32SLH-1
Internal I/O common	NPN	PNP	NPN	PNP
Output points	16 points			
I/O power supply voltage	20.4 to 26.4 V DC (24 V DC, -15% to 10%)			
Output current	0.5 A/point, 4.0 A/common			
Residual voltage	1.2 V max.			
Leakage current	0.1 mA max.			
ON delay time	0.5 ms max.			
OFF delay time	1.5 ms max.			
Disconnection detection	---			Operates at current consumption of 3 mA/point max. (Not detected at 3 mA or less.)
Output when error detected	According to hold/clear setting when error is detected. (The factory setting is for clear.)			

**Component Names and Functions**

**(Same for DRT2-MD32SL(-1) and DRT2-MD32SLH(-1))**

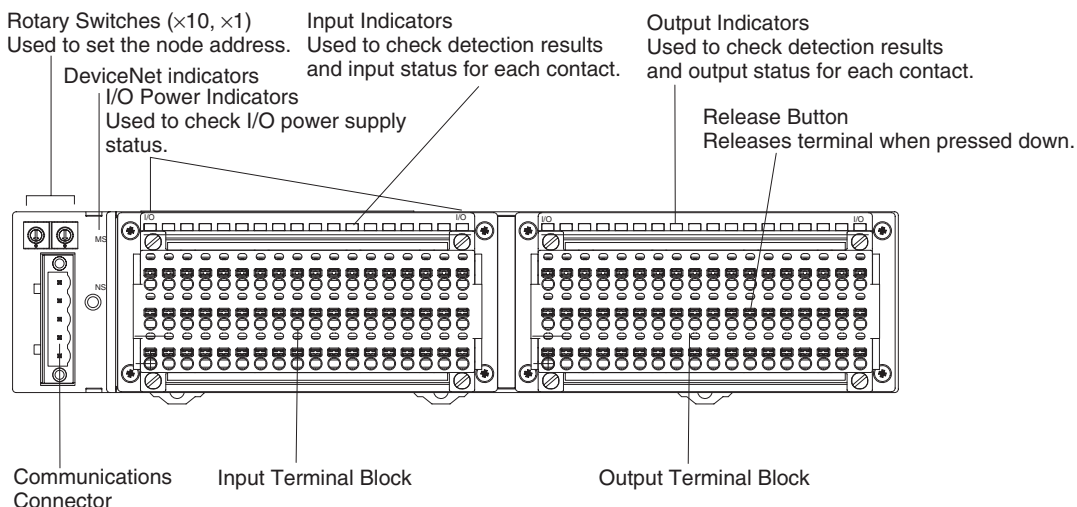

**Internal Circuits**

**DRT2-MD32SL (NPN)**

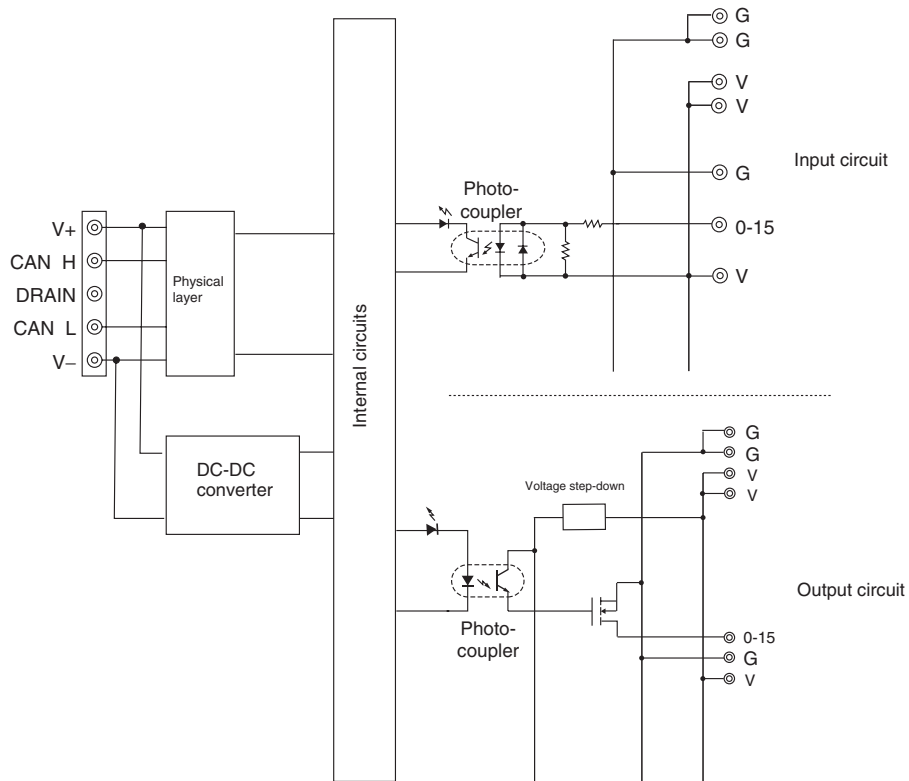

**DRT2-MD32SL-1 (PNP)**

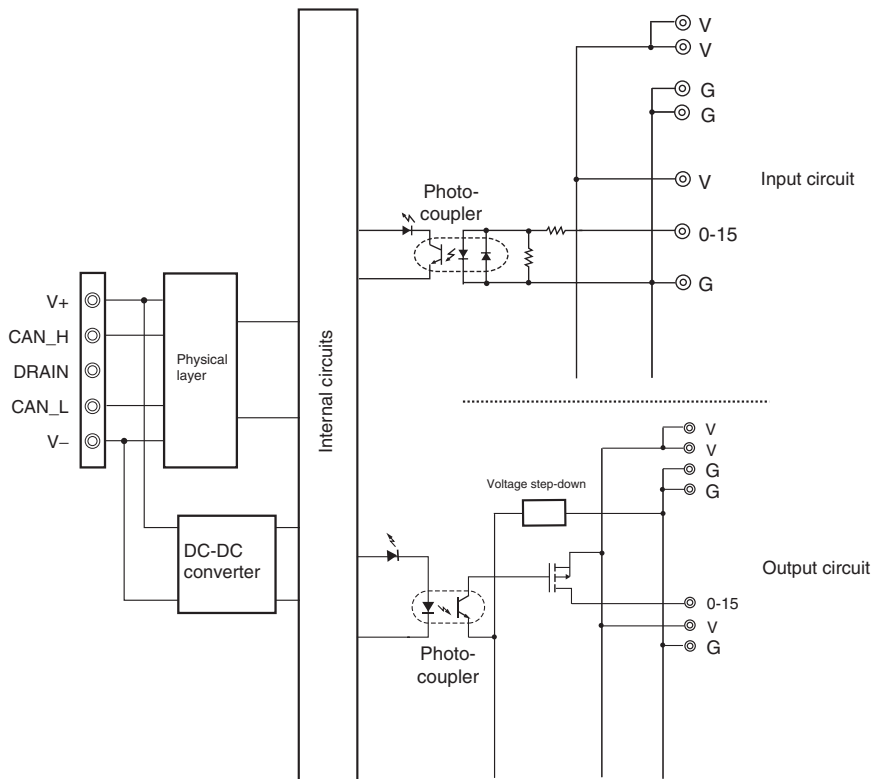

DRT2-MD32SLH (NPN)

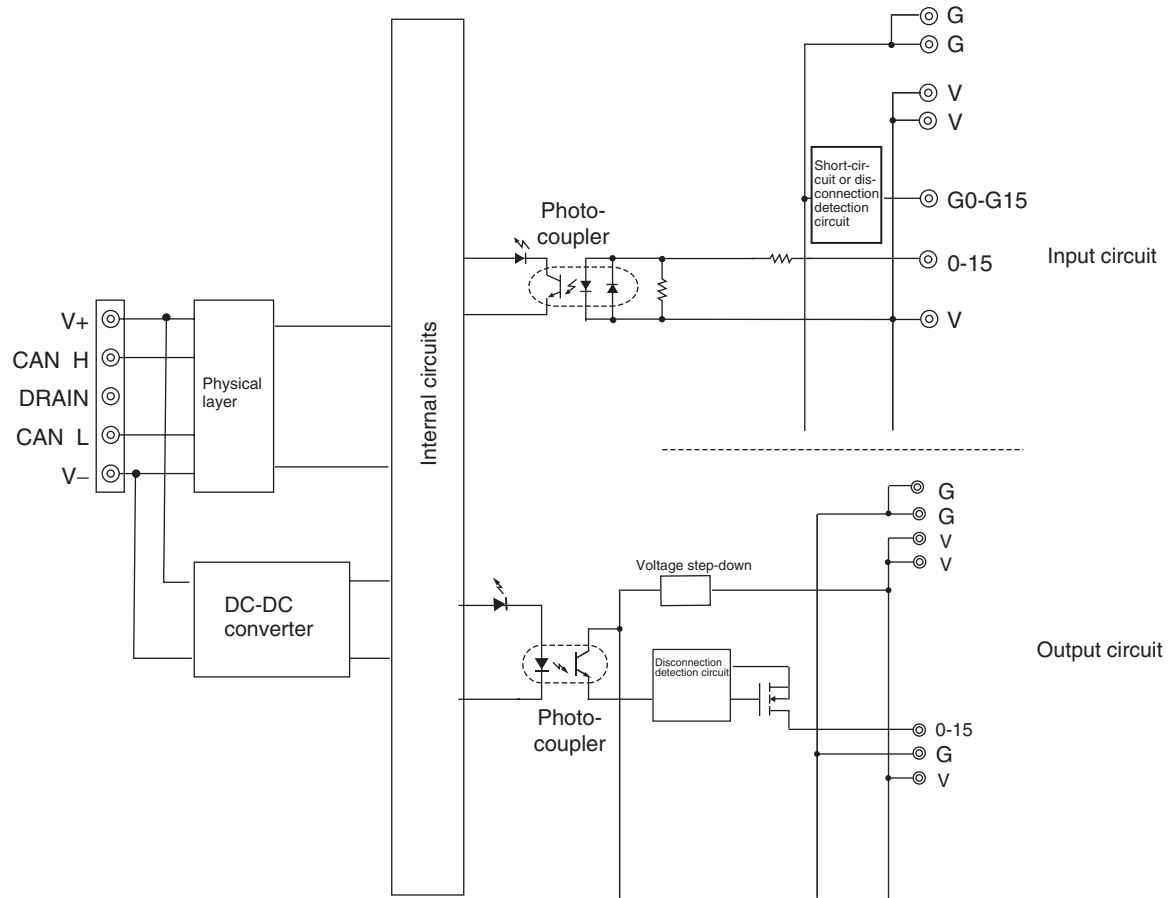

DRT2-MD32SLH-1 (PNP)

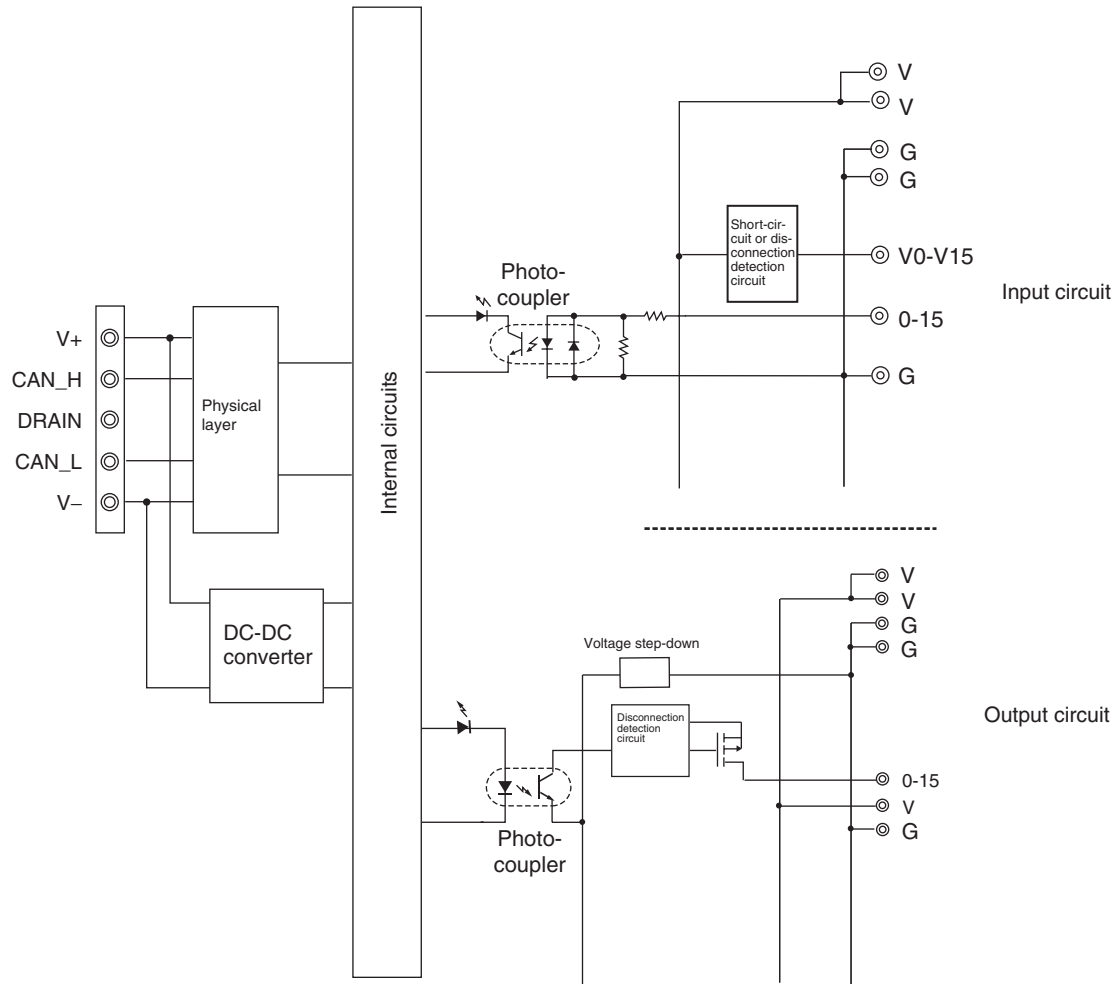

Wiring

DRT2-MD32SL (NPN)

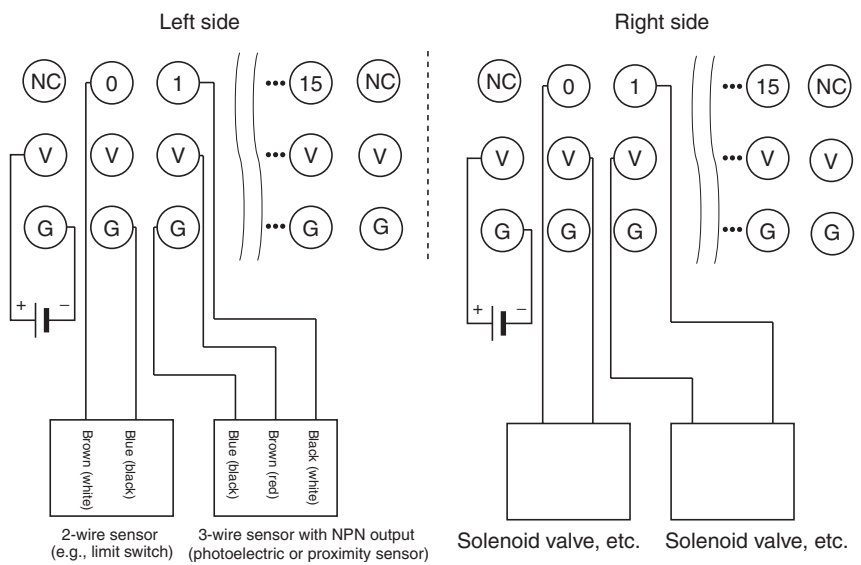

DRT2-MD32SL-1 (PNP)

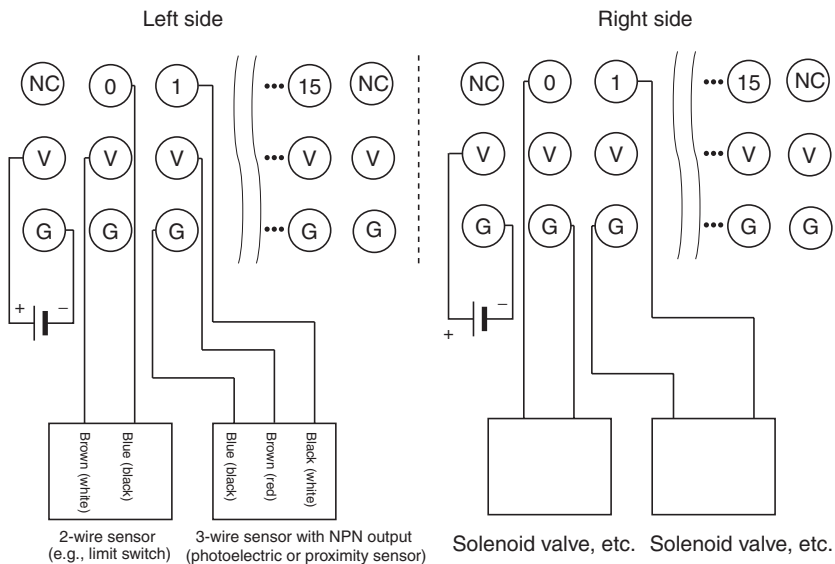

DRT2-MD32SLH (NPN)

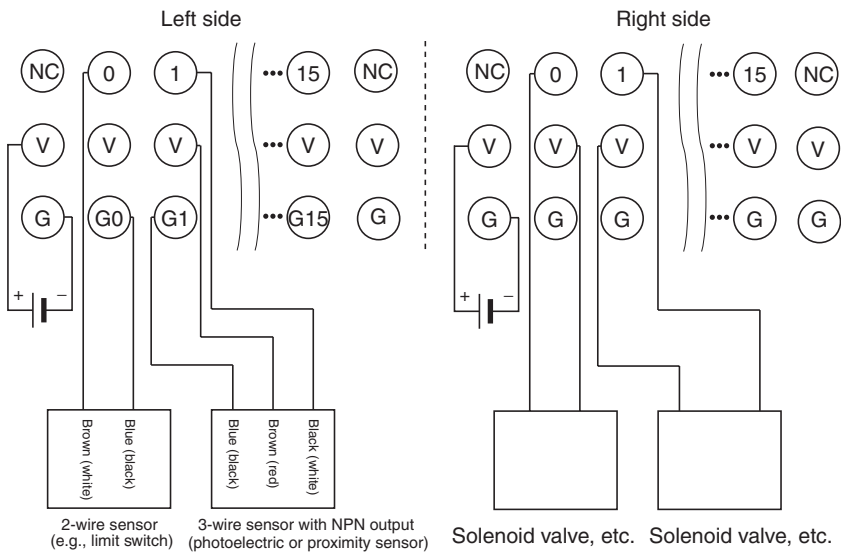

DRT2-MD32SLH-1 (PNP)

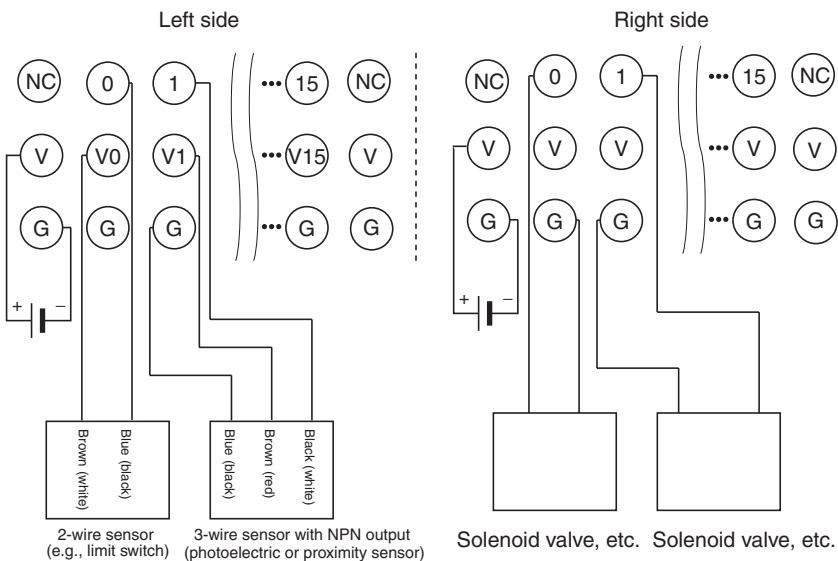

- Note**
1. The I/O power supply's right-side and left-side V terminals, and the right-side and left-side G terminals, are not connected internally. Supply power separately between V and G on the right and left sides respectively.
  2. When using inductive loads (such as solenoid valves), use a load with a built-in diode to absorb reverse power or attach a diode externally
  3. Wire colors have been changed according to revisions in the JIS standards for photoelectric and proximity sensors. The colors in parentheses are the wire colors prior to the revisions.

## Dimensions

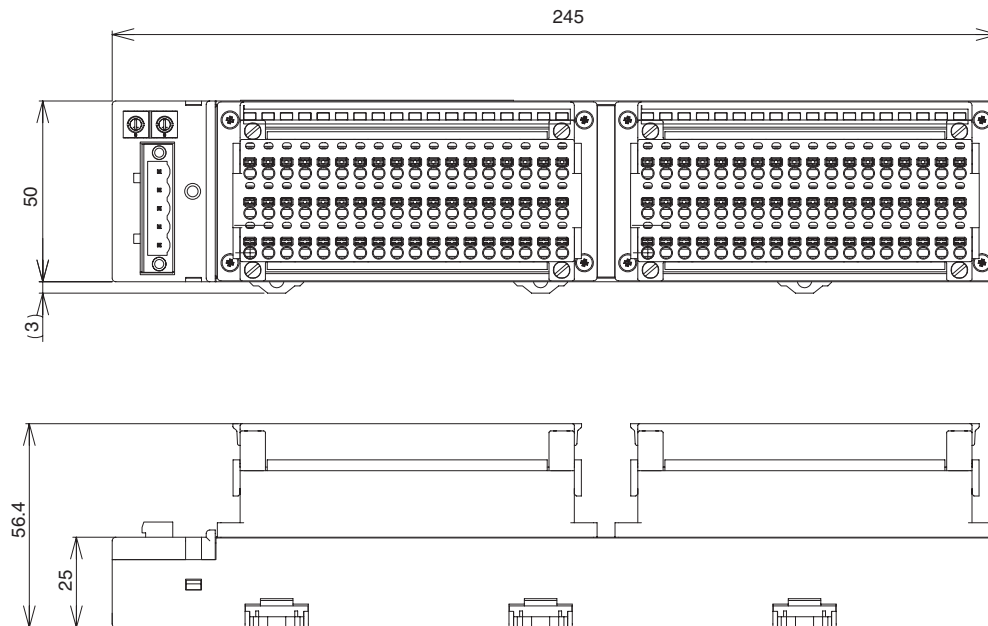

### 5-7-9 Mounting to a Control Panel

A Remote I/O Terminal (either a Basic Unit or Expansion Unit) can be mounted to a control panel as shown below.

#### Mounting to a DIN Track

Mount a 35-mm DIN Track to the rear panel of the Slave. Firmly insert the Slave into the DIN Track while pulling down the DIN Track mounting hooks on the rear panel with a screwdriver. Secure the Slave on the right and left sides between a pair of end plates.



**Mounting the End Plates**

First latch the bottom of the end plate (step 1 in the diagram below), and then latch the top and pull down (step 2 below).

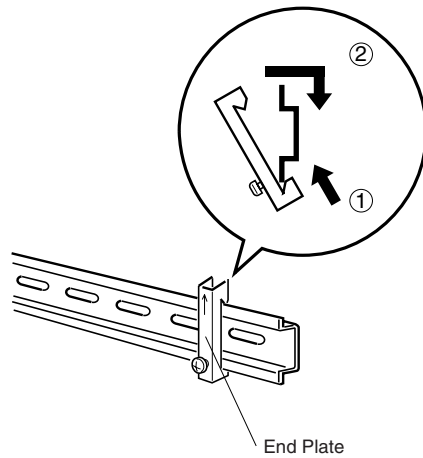

**Note** The Slave must be secured on both sides by a pair of end plates.

**Mounting Direction**

Unless specified in the Slave's documentation, there are no restrictions on the mounting direction. The Slave can be mounted in any of the six directions shown below.

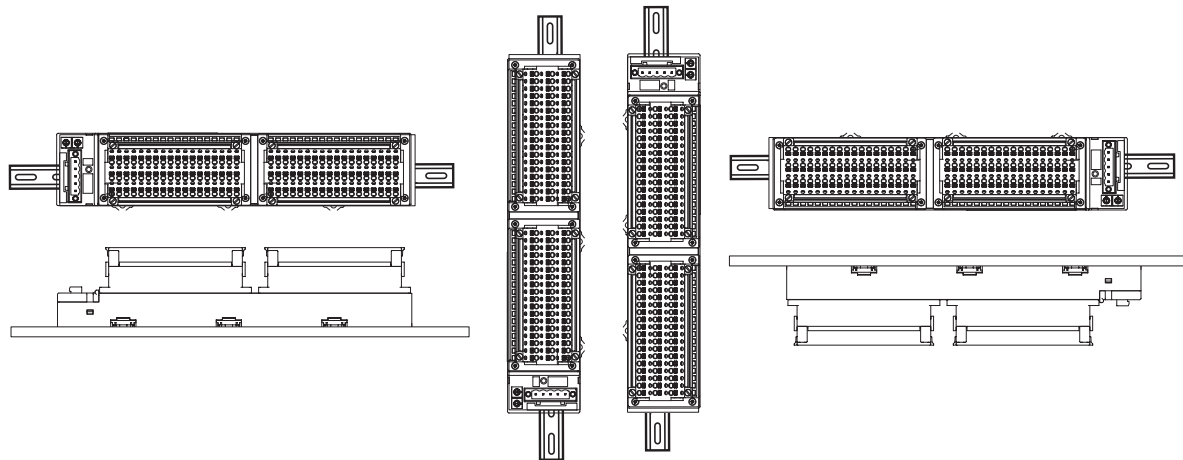

# SECTION 6

## Environment-resistive Slaves

This section provides the specifications and describes the components, terminal arrangements, basic procedures for wiring, and methods for connecting cables of Environment-resistive Slaves (conforming to IP67). Information on Slave settings, mounting and wiring methods are also provided separately for each Slave type.

6-1	Common Specifications for Environment-resistive Slaves . . . . .	234
6-1-1	Current Consumption, Weight, Enclosure Ratings . . . . .	235
6-1-2	I/O Indicators . . . . .	235
6-2	Connecting Communications Cables to Environment-resistive Slaves . . . . .	236
6-2-1	System with Slaves Using Round Connectors Only . . . . .	236
6-2-2	System with Slaves Using Round Connectors and Regular Square Connectors . . . . .	237
6-2-3	Communications Cables for Environment-resistive Terminals . . . . .	237
6-2-4	Example System Assembly . . . . .	239
6-3	Maintenance Information Window . . . . .	239
6-3-1	Checking Maintenance Information . . . . .	239
6-4	Advanced Environment-resistive Terminals . . . . .	245
6-4-1	Node Address, Baud Rate, and Output Hold/Clear Settings . . . . .	245
6-4-2	Environment-resistive Terminals with 8 Transistor Inputs (IP67): DRT2-ID08C (NPN) and DRT2-ID08C-1 (PNP) . . . . .	245
6-4-3	Environment-resistive Terminals with 16 Transistor Inputs (IP67): DRT2-HD16C (NPN) and DRT2-HD16C-1 (PNP) . . . . .	250
6-4-4	Environment-resistive Terminals with 8 Transistor Outputs (IP67): DRT2-OD08C (NPN) and DRT2-OD08C-1 (PNP) . . . . .	255
6-5	Standard Environment-resistive Terminals . . . . .	260
6-5-1	Node Address, Baud Rate, and Output Hold/Clear Settings . . . . .	260
6-5-2	Environment-resistive Terminals with 4 Transistor Inputs (IP67): DRT2-ID04CL (NPN) and DRT2-ID04CL-1 (PNP) . . . . .	261
6-5-3	Environment-resistive Terminals with 8 Transistor Inputs (IP67): DRT2-ID08CL (NPN) and DRT2-ID08CL-1 (PNP) . . . . .	265
6-5-4	Environment-resistive Terminals with 16 Transistor Inputs (IP67): DRT2-HD16CL (NPN) and DRT2-HD16CL-1 (PNP) . . . . .	268
6-5-5	Environment-resistive Terminals with 4 Transistor Outputs (IP67): DRT2-OD04CL (NPN) and DRT2-OD04CL-1 (PNP) . . . . .	272
6-5-6	Environment-resistive Terminals with 8 Transistor Outputs (IP67): DRT2-OD08CL (NPN) and DRT2-OD08CL-1 (PNP) . . . . .	275
6-5-7	Environment-resistive Terminals with 16 Transistor Outputs (IP67): DRT2-WD16CL (NPN) and DRT2-WD16CL-1 (PNP) . . . . .	278
6-5-8	Environment-resistive Terminals with 8 Transistor Inputs and 8 Transistor Outputs (IP67): DRT2-MD16CL (NPN) and DRT2-MD16CL-1 (PNP) . . . . .	282
6-6	Mounting and Wiring Environment-resistive Slaves . . . . .	286
6-6-1	Mounting in Control Panels . . . . .	286
6-6-2	Wiring the Internal Power Supply, I/O Power Supply, and I/O Lines . . . . .	286

## 6-1 Common Specifications for Environment-resistive Slaves

The following table lists specifications that are common to all Environment-resistive Slaves. For details on specifications for each Slave, refer to the following Slave specifications pages.

Item	Specifications
Communications power supply voltage	11 to 25 V DC (Supplied from the communications connector.)
I/O power supply voltage	20.4 to 26.4 V DC (24 V DC, -15 to +10%)
Noise immunity	Conforms to IEC61000-4-4. 2 kV (power lines)
Vibration resistance	10 to 150 Hz, 0.7-mm double amplitude
Shock resistance	150 m/s <sup>2</sup>
Dielectric strength	500 V AC (between isolated circuits)
Insulation resistance	20 M $\Omega$ min. (between isolated circuits)
Ambient temperature	-10 to +55°C
Ambient humidity	25% to 85% (with no condensation)
Operating environment	No corrosive gases
Storage temperature	-25 to +65°C
Enclosure rating	IP67
Mounting	M5 screws for both front and rear panel
Mounting strength	100 N
Communications connector strength	30 N
Screw tightening torque	Round connector (communications connectors, power supply, I/O): 0.39 to 0.49 N·m M5 (mounting Unit from front panel): 1.47 to 1.96 N·m

### 6-1-1 Current Consumption, Weight, Enclosure Ratings

The following table lists the current consumption, weight, and enclosure ratings for Environment-resistive Slaves.

Model	Communications current consumption	Weight	Enclosure rating
DRT2-ID08C	115 mA max.	340 g max.	IP67
DRT2-ID08C-1	115 mA max.	340 g max.	
DRT2-HD16C	190 mA max.	340 g max.	
DRT2-HD16C-1	190 mA max.	340 g max.	
DRT2-OD08C	60 mA max.	390 g max.	
DRT2-OD08C-1	60 mA max.	390 g max.	
DRT2-ID04CL	50 mA max.	275 g max.	
DRT2-ID04CL-1	50 mA max.	275 g max.	
DRT2-OD04CL	45 mA max.	275 g max.	
DRT2-OD04CL-1	45 mA max.	275 g max.	
DRT2-ID08CL	50 mA max.	390 g max.	
DRT2-ID08CL-1	50 mA max.	390 g max.	
DRT2-HD16CL	55 mA max.	390 g max.	
DRT2-HD16CL-1	55 mA max.	390 g max.	
DRT2-OD08CL	50 mA max.	390 g max.	
DRT2-OD08CL-1	50 mA max.	390 g max.	
DRT2-WD16CL	55 mA max.	390 g max.	
DRT2-WD16CL-1	55 mA max.	390 g max.	
DRT2-MD16CL	55 mA max.	390 g max.	
DRT2-MD16CL-1	55 mA max.	390 g max.	

### 6-1-2 I/O Indicators

#### Advanced Slaves (DRT2-□D□□C(-1))

The following table describes the meanings of the I/O indicators provided on Advanced Environment-resistive Slaves. Two I/O indicators, □-A and □-B, are provided for each connector.

Indicator	Color	Status	Definition	Meaning
□-A	Yellow	ON	Device operational	Input ON/Output ON
	Red	ON	Unrecoverable fault	Sensor power shorted
		Flashing	Minor fault	Sensor disconnected
	---	OFF	Device operational	Input OFF/output OFF/input power OFF
□-B	Yellow	ON	Device operational	Input ON
	Red	ON	Unrecoverable fault	Output load shorted
	---	OFF	Device operational	Input OFF/input power OFF

The box indicates the number of the corresponding connector.

**Standard Slaves**  
**(DRT2-□D□□CL(-1))**

The following table describes the meanings of the I/O indicators provided on Standard Environment-resistive Slaves. Two I/O indicators, □-A and □-B, are provided for each connector.

Indicator	Color	Status	Definition	Meaning
□-A	Yellow	ON	Device operational	Input ON/Output ON
	---	OFF	Device operational	Input OFF/output OFF/input power OFF
□-B	Yellow	ON	Device operational	Input ON
	---	OFF	Device operational	Input OFF/input power OFF

The box indicates the number of the corresponding connector.

## 6-2 Connecting Communications Cables to Environment-resistive Slaves

Communications cables are connected to Environment-resistive Slaves using round connectors.

Either Thin Cables or Thick Cables can be used as communications cables with the round connectors. Slaves that use the standard square connectors can also be connected to the Master Unit through a T-branch Tap.

The following wiring examples are for systems using Environment-resistive Slaves.

### 6-2-1 System with Slaves Using Round Connectors Only

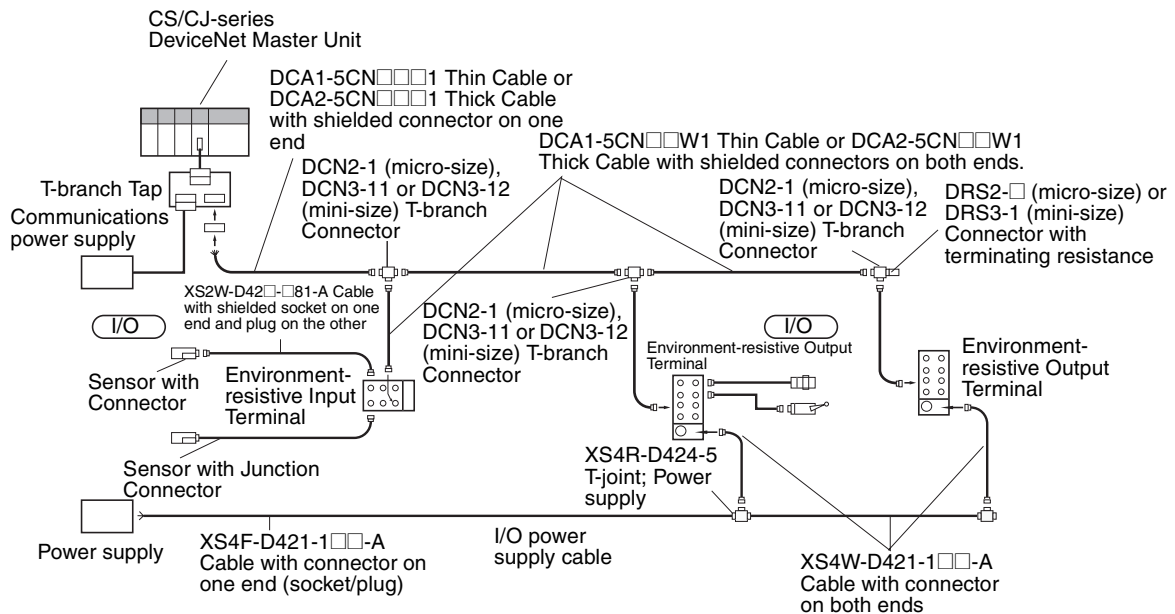

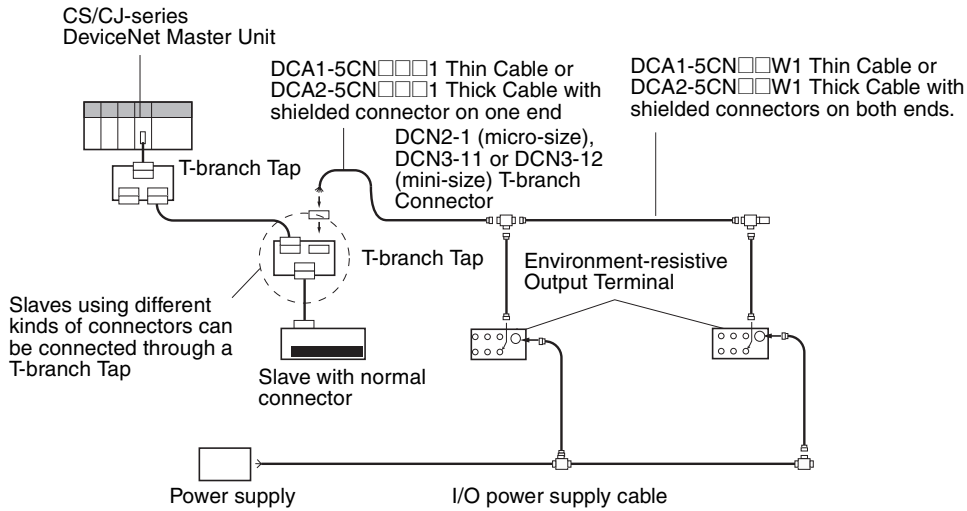

### 6-2-2 System with Slaves Using Round Connectors and Regular Square Connectors



### 6-2-3 Communications Cables for Environment-resistive Terminals

Always use the following communications cables with connectors with Environment-resistive Terminals.

#### Thin Cables with Connectors: Micro-size (previous M12)

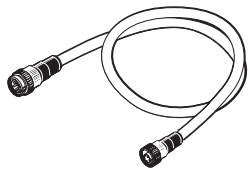
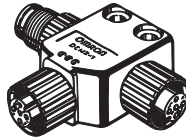

Model	Description
DCA1-5CN□□W1	Cable with shielded connectors on both ends 
DCA1-5CN□□F1	Cable with shielded connector (female socket) on one end 
DCA1-5CN□□H1	Cable with shielded connector (male plug) on one end 
DCA1-5CN□□W5	Cable with shielded connector on both ends (male plug on mini-size end, female socket on micro-size end) 
DCN2-1	Shielded T-branch Connector (for one branch line) 

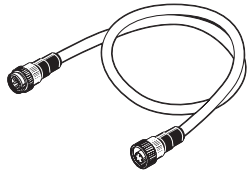
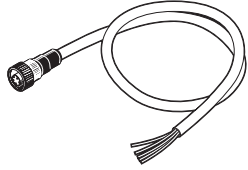
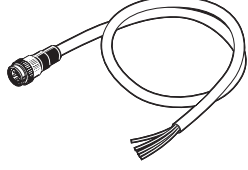
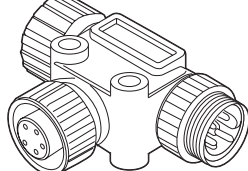
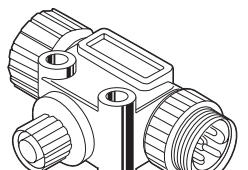
**Thick Cables with Connectors: Mini-size**

Model	Description
DCA2-5CN□□W1	Cable with shielded connectors on both ends 
DCA2-5CN□□F1	Cable with shielded connector (female socket) on one end 
DCA2-5CN□□H1	Cable with shielded connector (male plug) on one end 
DCN3-11	Shielded T-branch Connector (for one branch line) 
DCN3-12	Shielded T-branch Connector (for one branch line)  An M12 connector is used for the branch line. 

- Note**
1. The boxes in the model numbers indicate the cable length in 1-m units. A cable of 0.5 m, however, is indicated as “C5.”
  2. Standard DeviceNet cables are used for these connections, so the cables cannot be used in environments subject to spattering, unless measures are taken to protect the cables.

The following connectors with built-in terminating resistance are also available. A Terminating Resistor can also be connected to a T-branch Connector.

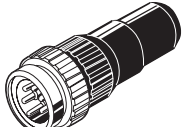
Model	Details
DRS2-1	Shielded Connector (male plug, micro-size) with terminating resistance. 
DRS2-2	Shielded Connector (female socket, micro-size) with terminating resistance. 
DRS3-1	Shielded Connector (male plug, mini-size) with terminating resistance. 

**Note** The allowable current of Thin Cables with shielded connectors is 3 A, and for Thick Cables the allowable current is 8 A.

Multi-drop wiring cannot be used for round communications connectors. Use T-branch wiring and T-branch Taps to connect cables with shielded connectors on both ends.

The rated current capacity of the T-branch Connector's communications power supply pin is 3 A.

A cable with a connector (socket) on one end can be used to connect to a standard DCN1-□C T-branch Tap. A cable with a connector (socket) on one end can also be used to connect to the communications power supply from a T-branch Connector.

### 6-2-4 Example System Assembly

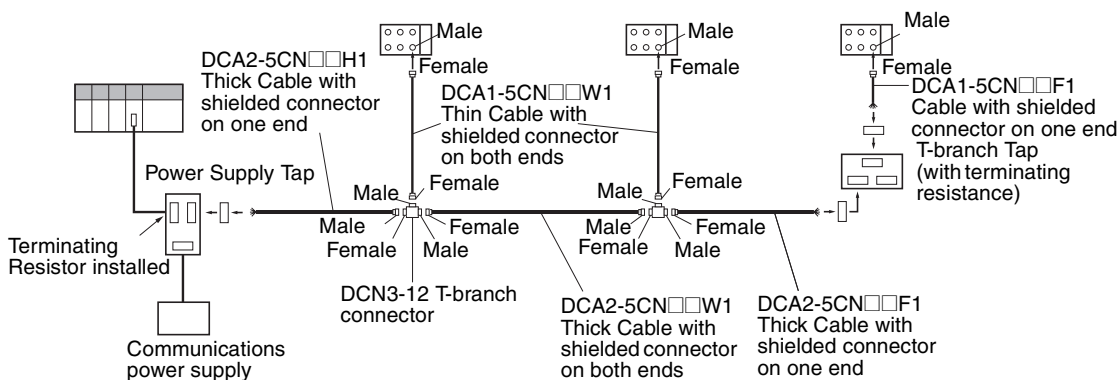

**Note** Tighten the connector by hand to a torque of 0.39 to 0.49 N·m. If the connector is not tightened sufficiently, it will not provide the expected degree of protection and may become loose due to vibration.

Do not use pliers or other tools to tighten the connectors, because these tools may damage the connectors.

## 6-3 Maintenance Information Window

This section describes the Maintenance Information Window, which can be used to check the status of Environment-resistive Slaves. The Monitor Device Window can be used to check the same Slave status information, but the examples in this section uses the Maintenance Information Window. Refer to 4-1-2 Maintenance Mode Window for details on the differences between the Maintenance Information Window and the Monitor Device Window.

### 6-3-1 Checking Maintenance Information

From the DeviceNet Configurator's Main Window, click the right mouse button and select **Maintenance Information**. (From the Maintenance Mode Window, double-click the icon of the desired Slave.)



**General Window**

**Window for the DRT2-HD16C(-1) and DRT2-ID08C(-1)**

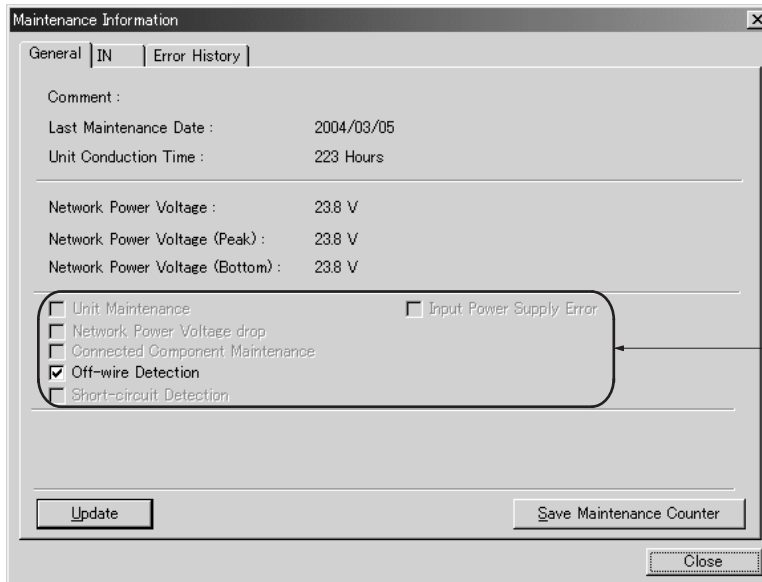

Status check boxes (Status flags)

**Window for the DRT2-OD08C(-1)**

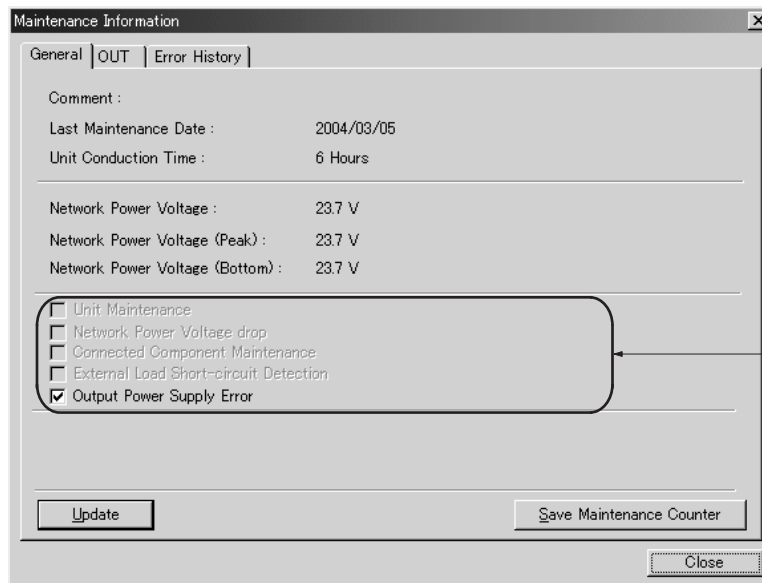

Status check boxes (Status flags)

Window for the DRT2-HD16CL(-1), DRT2-ID08CL(-1), and DRT2-ID04CL(-1)

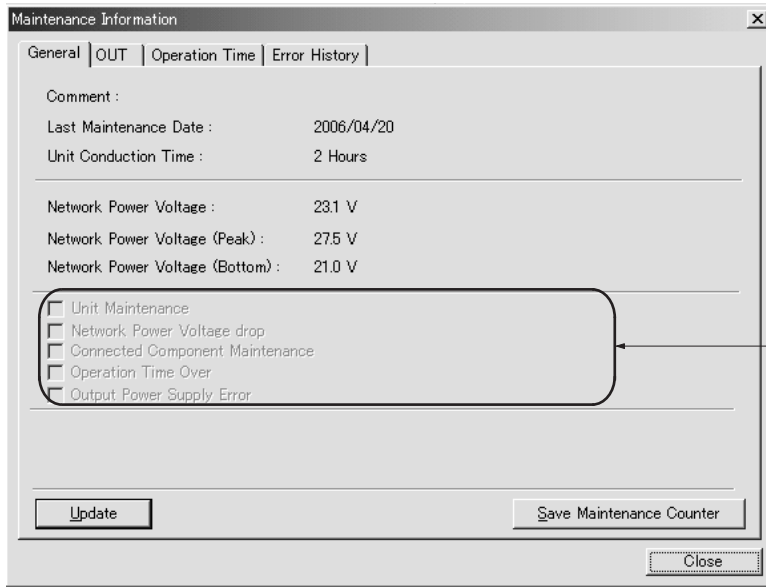

Status check boxes (Status flags)

Window for the DRT2-WD16CL(-1), DRT2-OD08CL(-1), and DRT2-OD04CL(-1)

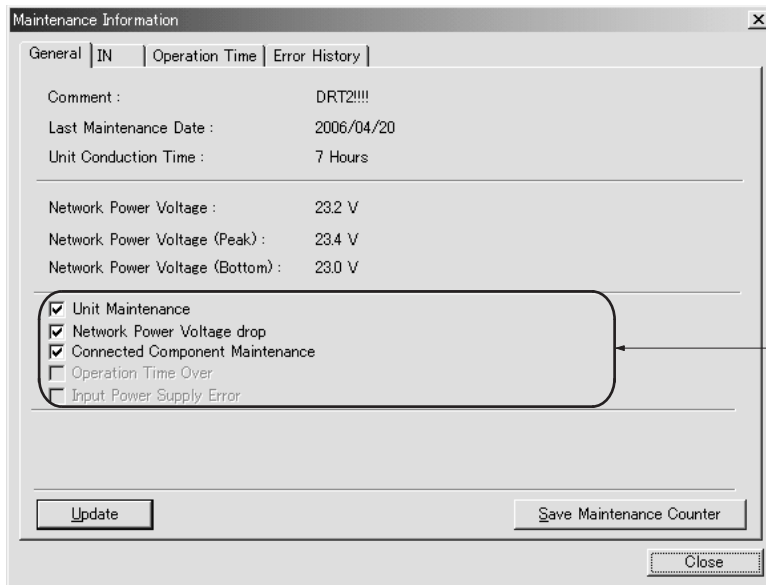

Status check boxes (Status flags)

Window for the DRT2-MD16CL(-1)

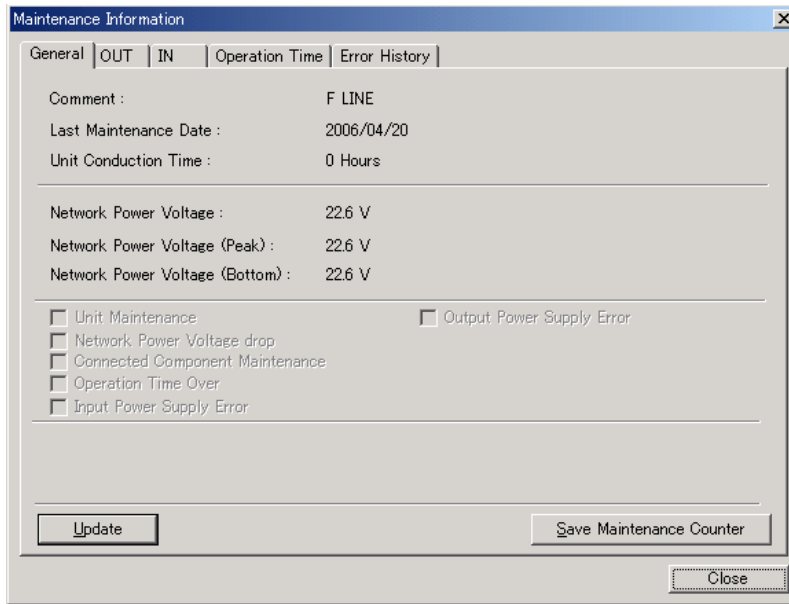

Item	Description
Comment	Displays up to 32 characters of text set as the Unit comment.
Last Maintenance Date	Displays the last maintenance date that was set.
Unit Conduction Time	Displays the total time that the Unit has been ON (cumulative power ON time).
Network Power Voltage	Displays the present network power supply voltage.
Network Power Voltage (Peak)	Displays the maximum power supply voltage up to the present time.
Network Power Voltage (Bottom)	Displays the minimum power supply voltage up to the present time.
Update Button	Click this Button to update the Maintenance information.
Save Maintenance Counter	This function saves the Maintenance counter value in the Unit. If this function is used, the previous value will be retained when the power supply is turned OFF and ON again.

**Note** Always update the information when the parameters have been edited or set.

**Status Check Boxes**

The flags (check boxes) shown in the following table will be turned ON when the corresponding error occurs.

Item	Description
Unit Maintenance	ON when the total Unit ON time exceeds the set value.
Network Power Voltage Drop	ON when the network power supply voltage falls below the set value.
Connected Device Maintenance	ON when any I/O point's Total ON Time Monitor or Contact Operation Counter exceeds its user-set monitor value.
Sensor Disconnected Detection (Advanced Slaves only)	ON when the Sensor Disconnection Detection function detects a disconnection in an input.

Item	Description
Sensor Power Short-circuit Detection (Advanced Slaves only)	ON when the Sensor Power Short-circuit Detection function detects a short circuit in a sensor power supply.
External Load Short-circuit Detection (Advanced Slaves only)	ON when the External Load Short-circuit Detection function detects a short circuit in an output load.
I/O Power Supply Error (Output)	ON when the output power supply is OFF.
I/O Power Supply Error (Input)	ON when the input power supply is OFF.

**Tabs in the Maintenance Information Window**

**IN Tab Page**

Terminals are listed in numerical order.

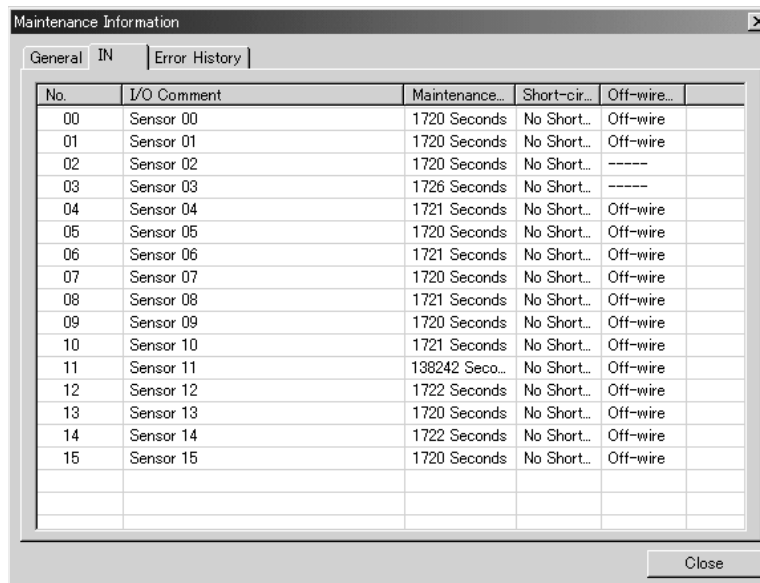

Item	Description
Comment	Displays up to 32 characters of text set as the input comment for each input.
Maintenance Counter	Displays the maintenance counter for each input. If the maintenance counter exceeds the threshold value, a warning icon will be displayed on the left side of the input's No. column. Total ON Time Monitor: Units = seconds Contact Operation Counter: Units = operations
Power Supply Short-circuit	When sensor power short-circuit detection is ON for each input, <i>Shorted</i> will be displayed.
Disconnection Detection History	Records information when a disconnection occurred even once.

**Note** Power Supply Short-circuit and Disconnection Error History are supported for Advanced Slaves only.

OUT Tab Page

Terminals are listed in numerical order.

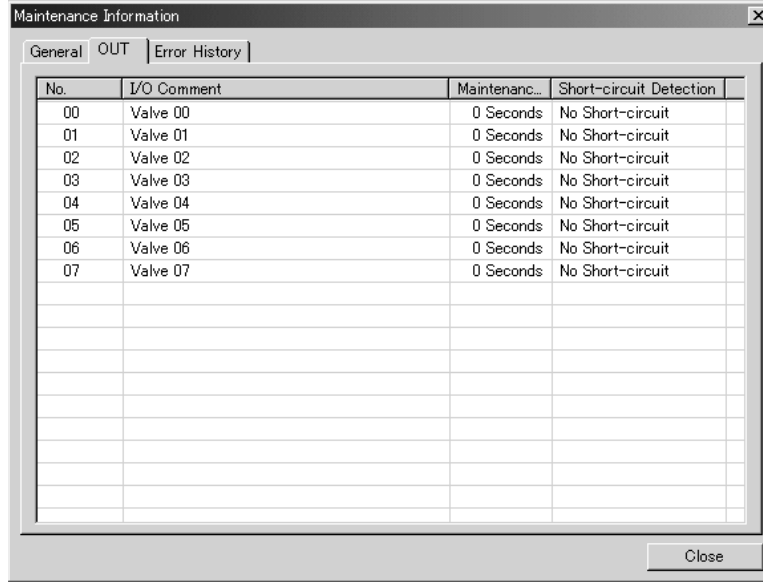

Item	Description
Comment	Displays up to 32 characters of text set as the output comment for each output.
Maintenance Counter	Displays the maintenance counter for each output. If the maintenance counter exceeds the threshold value, a warning icon will be displayed on the left side of the output's No. column. Total ON Time Monitor: Units = seconds Contact Operation Counter: Units = operations
External Load Short-circuit Detection	If a load short circuit is detected, <i>Shorted</i> will be displayed.

**Note** Load Short-circuit Detection is supported for Advanced Slaves only.

Error History Tab Page

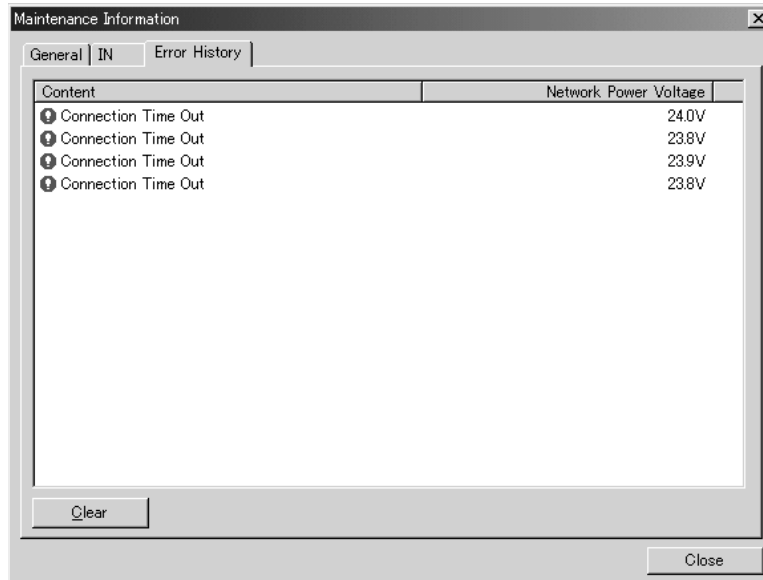

Item	Description
Content	Displays the contents of the communications errors that occurred.
Network Power Voltage	Displays the power supply voltage being supplied when the error occurred.
Clear Button	Clears the error history.

## 6-4 Advanced Environment-resistive Terminals

### 6-4-1 Node Address, Baud Rate, and Output Hold/Clear Settings

This section describes the Environment-resistive Terminal's node address setting, baud rate settings, and hold/clear outputs for communications error setting. These settings are made as follows:

Node address setting: Rotary switches

Baud rate setting: Automatic follow-up

Output hold/clear setting: Software switch

#### Node Address Settings

The node address of the Environment-resistive Terminal is set as a decimal, using the top rotary switch for the ten's digit, and the bottom rotary switch for the one's digit.

Any node address within the setting range can be used as long as it is not already set for another node.

Refer to *SECTION 5 General-purpose Slaves* for details on setting from the Configurator.

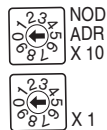

- Note**
1. Setting the same node address for more than one node will cause a node address duplication error and communications will not start.
  2. Always turn OFF the power (including the communications power supply) to the Slave before setting.

#### Baud Rate Setting

The baud rate of the whole system is determined by the baud rate set for the Master Unit. Setting the baud rate for each Unit is not required.

#### Output Hold/Clear Setting

Use the Configurator to set the output hold/clear settings. The factory setting is for outputs to be cleared. Refer to *SECTION 5 General-purpose Slaves* for setting details.

### 6-4-2 Environment-resistive Terminals with 8 Transistor Inputs (IP67): DRT2-ID08C (NPN) and DRT2-ID08C-1 (PNP)

#### Input Specifications

Item	Specifications	
Model	DRT2-ID08C	DRT2-ID08C-1
Internal I/O common	NPN	PNP
Input points	8 points (uses one word in the Master)	

Item	Specifications	
ON voltage	9 V DC min. (between each input terminal and V)	9 V DC min. (between each input terminal and G)
OFF voltage	5 V DC max. (between each input terminal and V)	5 V DC max. (between each input terminal and G)
OFF current	1 mA max.	
Input current	3 mA min./point (at 11 V DC) 11 mA max./point (at 24 V DC)	
Sensor power supply voltage	Maximum communications power supply voltage: +0 V Minimum communications power supply voltage: -1.5 V	
ON delay time	1.5 ms max.	
OFF delay time	1.5 ms max.	
Number of circuits	8 points with one common	

### I/O Status Indicators

The I/O status indicator displays and their meanings are shown in the following table. Refer to the section following on names of components and functions for details on the location of the I/O status indicators. In the indicator name "1-A," the "1" indicates the connector number, and the "A" indicates that it is an I/O status indicator.

Indicator	Color	Status	Meaning
1-A	Yellow	ON	Input 0 is ON.
	Red	ON	The sensor power of connector 1 has shorted.
	Red	Flashing	The sensor of connector 1 is disconnected.
2-A	Yellow	ON	Input 1 is ON.
	Red	ON	The sensor power of connector 2 has shorted.
	Red	Flashing	The sensor of connector 2 is disconnected.
3-A	Yellow	ON	Input 2 is ON.
	Red	ON	The sensor power of connector 3 has shorted.
	Red	Flashing	The sensor of connector 3 is disconnected.
4-A	Yellow	ON	Input 3 is ON.
	Red	ON	The sensor power of connector 4 has shorted.
	Red	Flashing	The sensor of connector 4 is disconnected.
5-A	Yellow	ON	Input 4 is ON.
	Red	ON	The sensor power of connector 5 has shorted.
	Red	Flashing	The sensor of connector 5 is disconnected.
6-A	Yellow	ON	Input 5 is ON.
	Red	ON	The sensor power of connector 6 has shorted.
	Red	Flashing	The sensor of connector 6 is disconnected.
7-A	Yellow	ON	Input 6 is ON.
	Red	ON	The sensor power of connector 7 has shorted.
	Red	Flashing	The sensor of connector 7 is disconnected.
8-A	Yellow	ON	Input 7 is ON.
	Red	ON	The sensor power of connector 8 has shorted.
	Red	Flashing	The sensor of connector 8 is disconnected.

- Note**
1. The I/O status indicator “B” is not used by Units with 8 inputs.
  2. Although the connectors are numbered from 1 to 8, the input bits are numbered from 0 to 7. (The input bits are also numbered from 0 to 7 in the Configurator display.)

**Component Names and Functions: DRT2-ID08C and DRT2-ID08C-1**

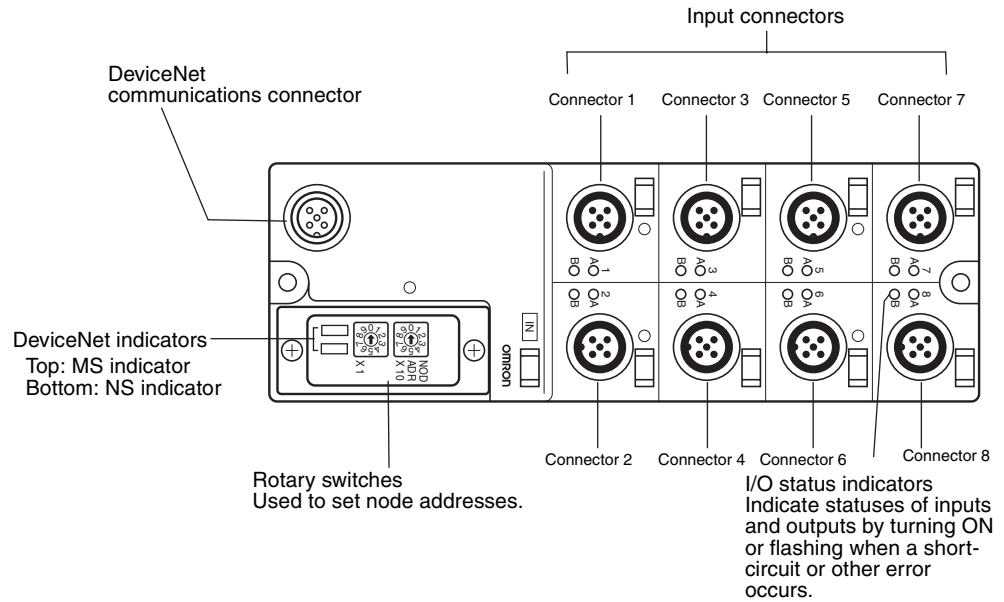

**Internal Circuits**

**DRT2-ID08C (NPN)**

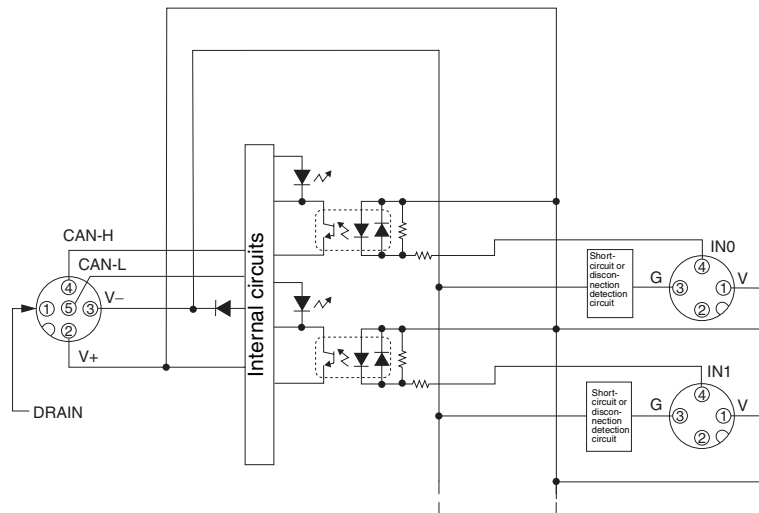



DRT2-ID08C-1 (PNP)

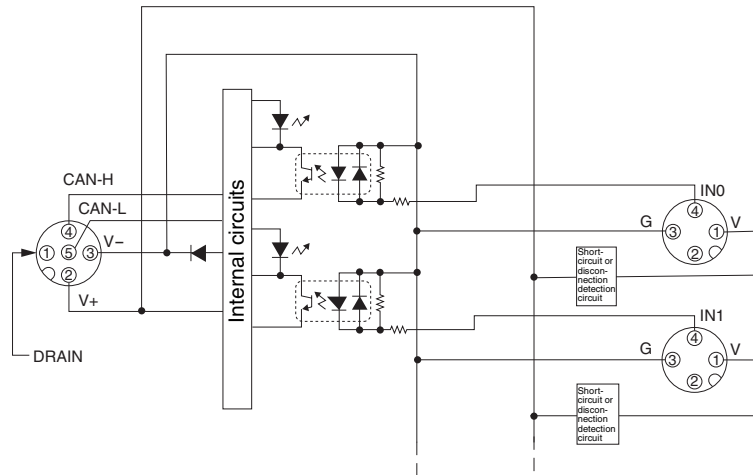

Wiring

DRT2-ID08C (NPN)

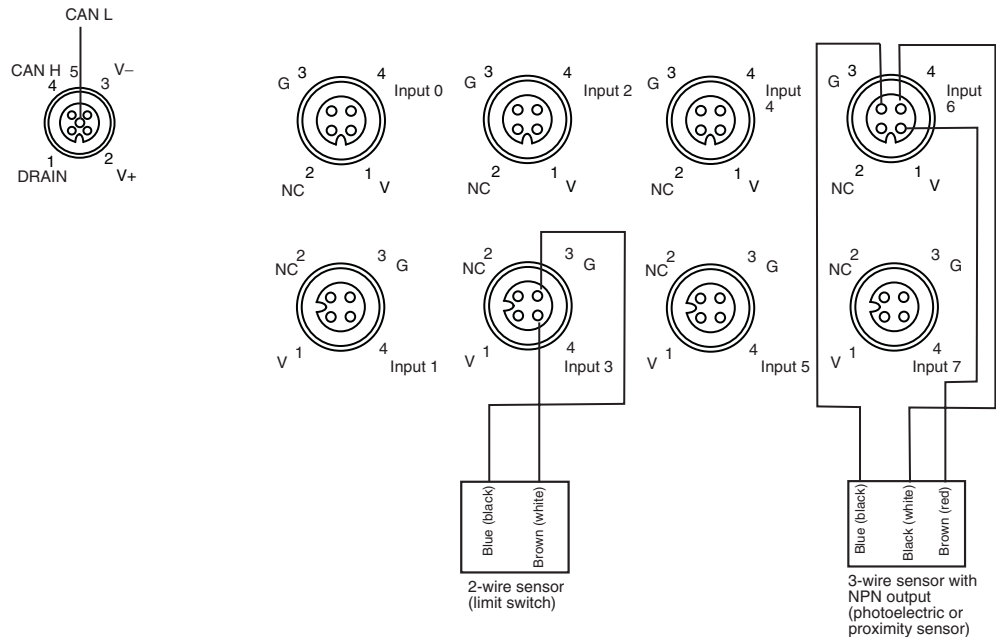

DRT2-ID08C-1 (PNP)

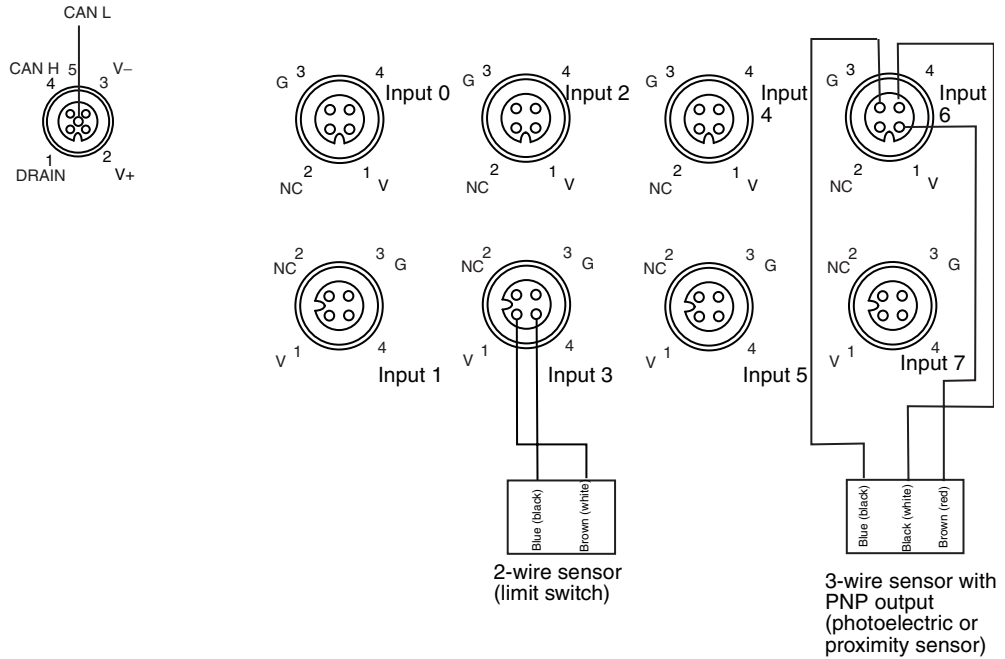

- Note**
1. Wire colors in parentheses are the previous JIS colors for photoelectric and proximity sensors.
  2. The minimum sensor power supply voltage is a communications power supply voltage of -1.5 V. Confirm the rated power supply voltage of the connected sensors when selecting the power supply. Refer to *Appendix E Current Consumption Summary* before setting the communications power supply voltage.

**Dimensions: DRT2-ID08C and DRT2-ID08C-1**

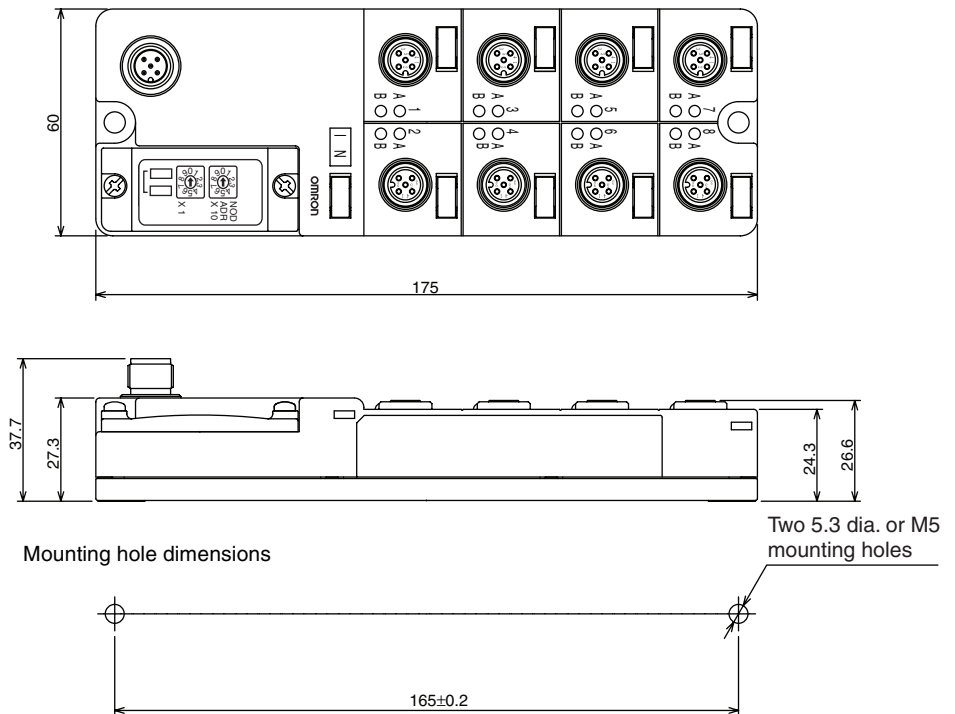

### 6-4-3 Environment-resistive Terminals with 16 Transistor Inputs (IP67): DRT2-HD16C (NPN) and DRT2-HD16C-1 (PNP)

#### Input Specifications

Item	Specifications	
Model	DRT2-HD16C	DRT2-HD16C-1
Internal I/O common	NPN	PNP
Input points	16 points	
ON voltage	9 V DC min. (between each input terminal and V)	9 V DC min. (between each input terminal and G)
OFF voltage	5 V DC max. (between each input terminal and V)	5 V DC max. (between each input terminal and G)
OFF current	1 mA max.	
Input current	3 mA min./point (at 11 V DC) 11 mA max./point (at 24 V DC)	
Sensor power supply voltage	Maximum communications power supply voltage: +0 V Minimum communications power supply voltage: -1.5 V	
ON delay time	1.5 ms max.	
OFF delay time	1.5 ms max.	
Number of circuits	16 points with one common	

#### I/O Status Indicators

The I/O status indicator displays and their meanings are shown in the following table. Refer to the section following on names of parts and functions for details on the location of the I/O status indicators. In the indicator name "1-A," the "1" indicates the connector number, and the "A" indicates that it is an I/O status indicator.

Indicator	Color	Status	Meaning
1-A	Yellow	ON	Input 0 is ON.
	Red	ON	The sensor power of connector 1 has shorted.
	Red	Flashing	The sensor of connector 1 is disconnected.
1-B	Yellow	ON	Input 1 is ON.
2-A	Yellow	ON	Input 2 is ON.
	Red	ON	The sensor power of connector 2 has shorted.
	Red	Flashing	The sensor of connector 2 is disconnected.
2-B	Yellow	ON	Input 3 is ON.
3-A	Yellow	ON	Input 4 is ON.
	Red	ON	The sensor power of connector 3 has shorted.
	Red	Flashing	The sensor of connector 3 is disconnected.
3-B	Yellow	ON	Input 5 is ON.

Indicator	Color	Status	Meaning
4-A	Yellow	ON	Input 6 is ON.
	Red	ON	The sensor power of connector 4 has shorted.
	Red	Flashing	The sensor of connector 4 is disconnected.
4-B	Yellow	ON	Input 7 is ON.
5-A	Yellow	ON	Input 8 is ON.
	Red	ON	The sensor power of connector 5 has shorted.
	Red	Flashing	The sensor of connector 5 is disconnected.
5-B	Yellow	ON	Input 9 is ON.
6-A	Yellow	ON	Input 10 is ON.
	Red	ON	The sensor power of connector 6 has shorted.
	Red	Flashing	The sensor of connector 6 is disconnected.
6-B	Yellow	ON	Input 11 is ON.
7-A	Yellow	ON	Input 12 is ON.
	Red	ON	The sensor power of connector 7 has shorted.
	Red	Flashing	The sensor of connector 7 is disconnected.
7-B	Yellow	ON	Input 13 is ON.
8-A	Yellow	ON	Input 14 is ON.
	Red	ON	The sensor power of connector 8 has shorted.
	Red	Flashing	The sensor of connector 8 is disconnected.
8-B	Yellow	ON	Input 15 is ON.

**Note** Although the connectors are numbered from 1 to 8, the input bits are numbered from 0 to 7. (The input bits are also numbered from 0 to 7 in the Configurator display.)

**Component Names and Functions: DRT2-HD16C and DRT2-HD16C-1**

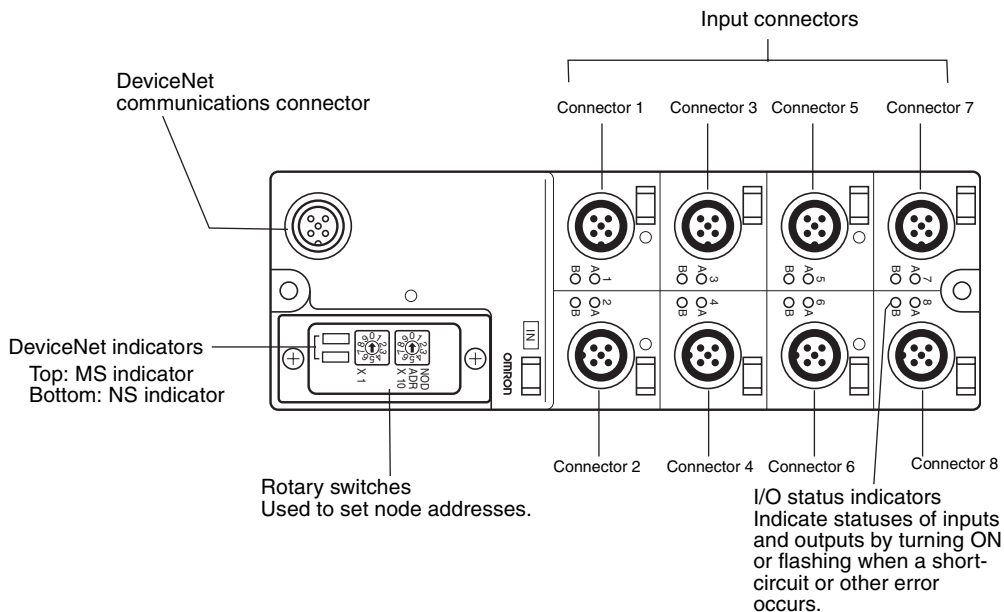

**Internal Circuits**

**DRT2-HD16C (NPN)**

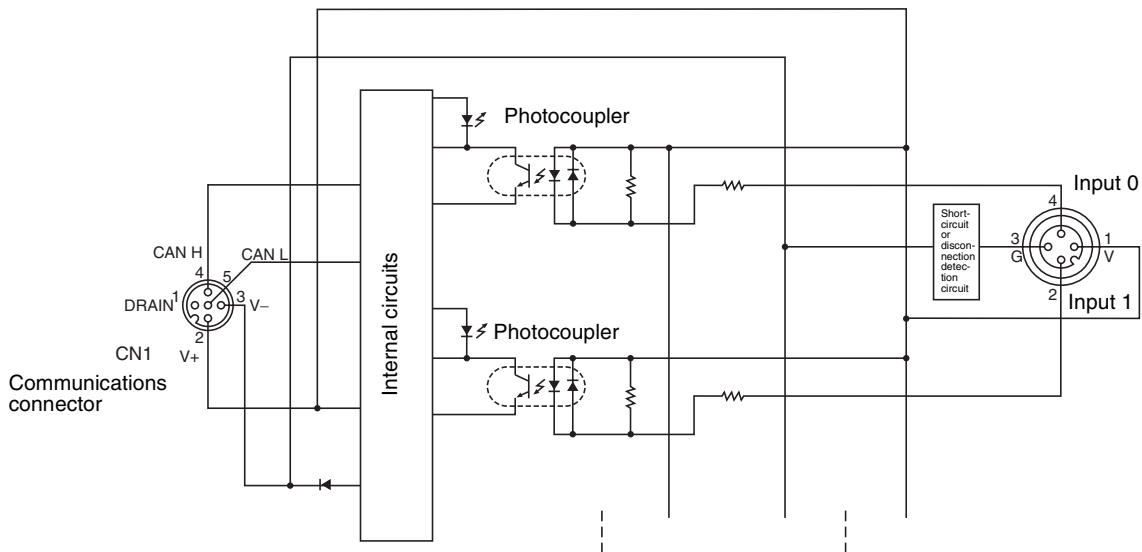

DRT2-HD16C-1 (PNP)

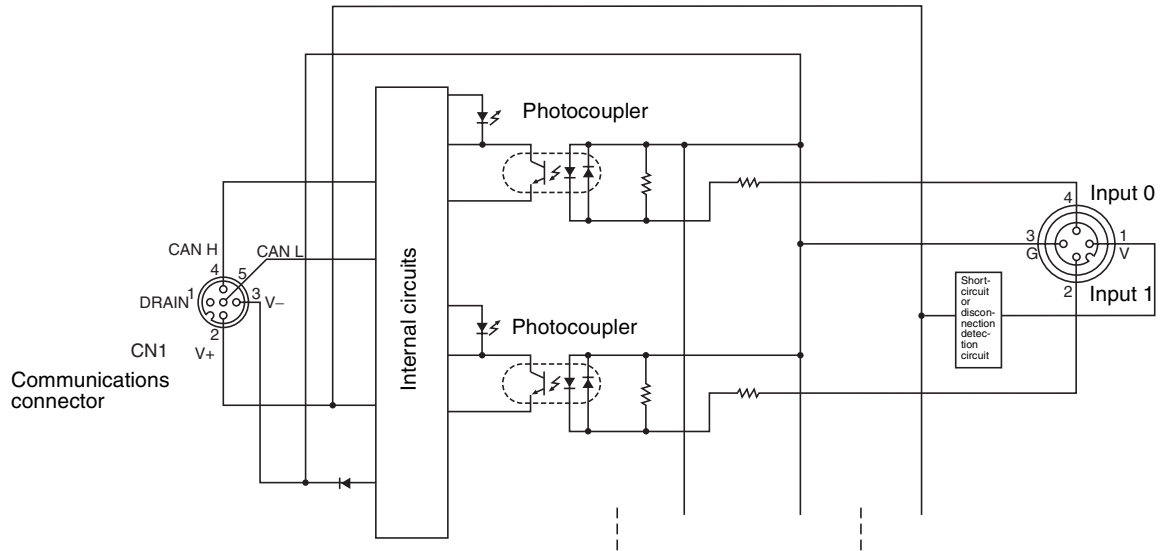

Wiring

DRT2-HD16C (NPN)

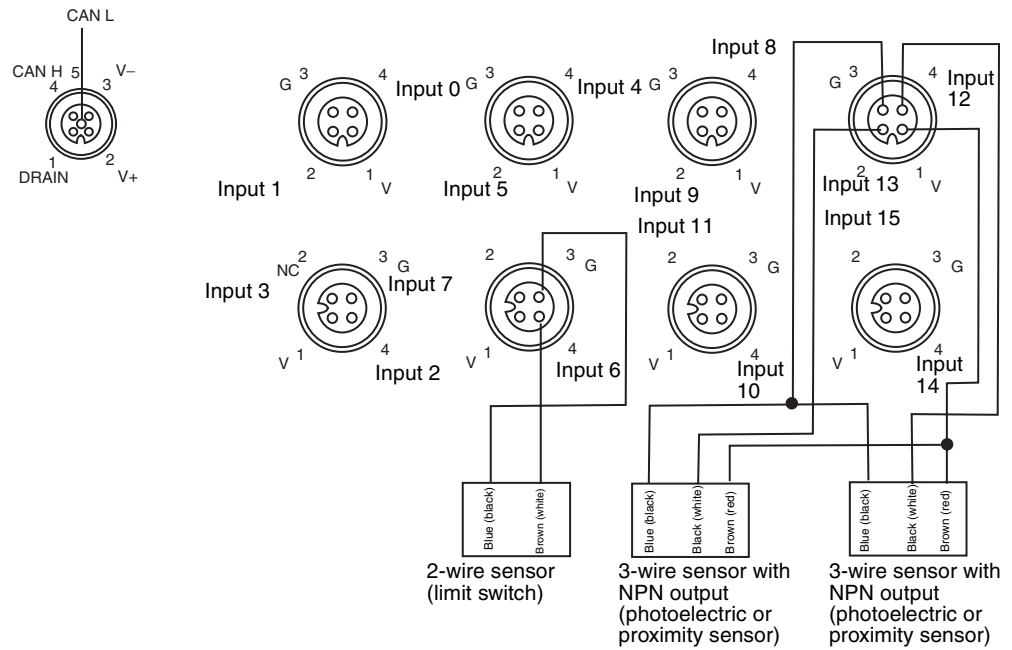

DRT2-HD16C-1 (PNP)

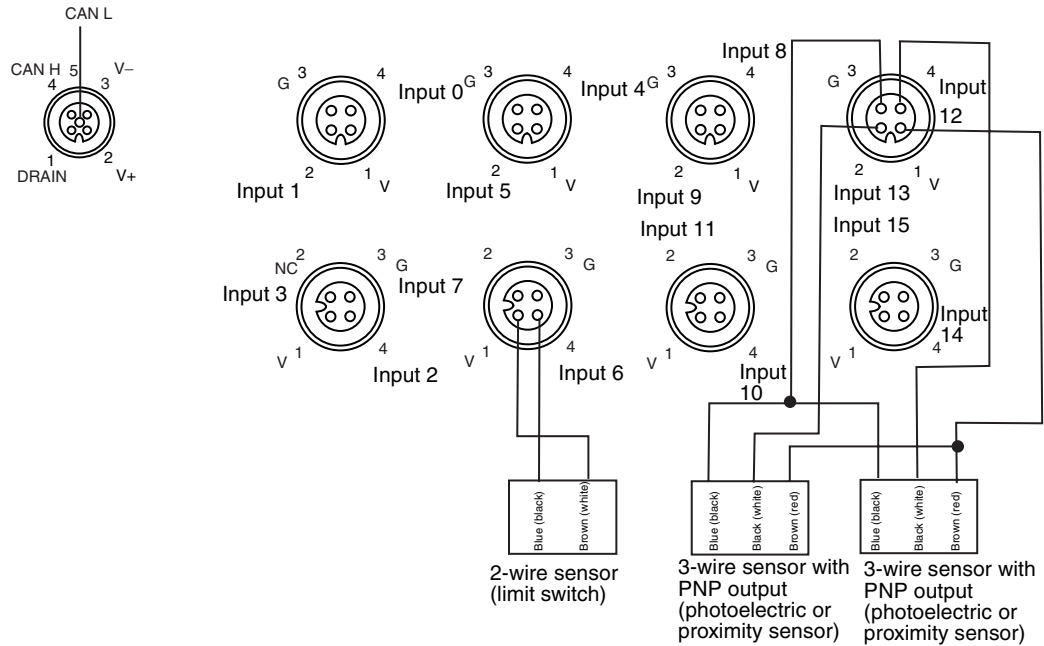

- Note**
1. Wire colors in parentheses are the previous JIS colors for photoelectric and proximity sensors.
  2. The minimum sensor power supply voltage is a communications power supply voltage of  $-1.5$  V. Confirm the rated power supply voltage of the connected sensors when selecting a power supply. Refer to *Appendix E Current Consumption Summary* before setting the communications power supply voltage.

**Dimensions: DRT2-HD16C and DRT2-HD16C-1**

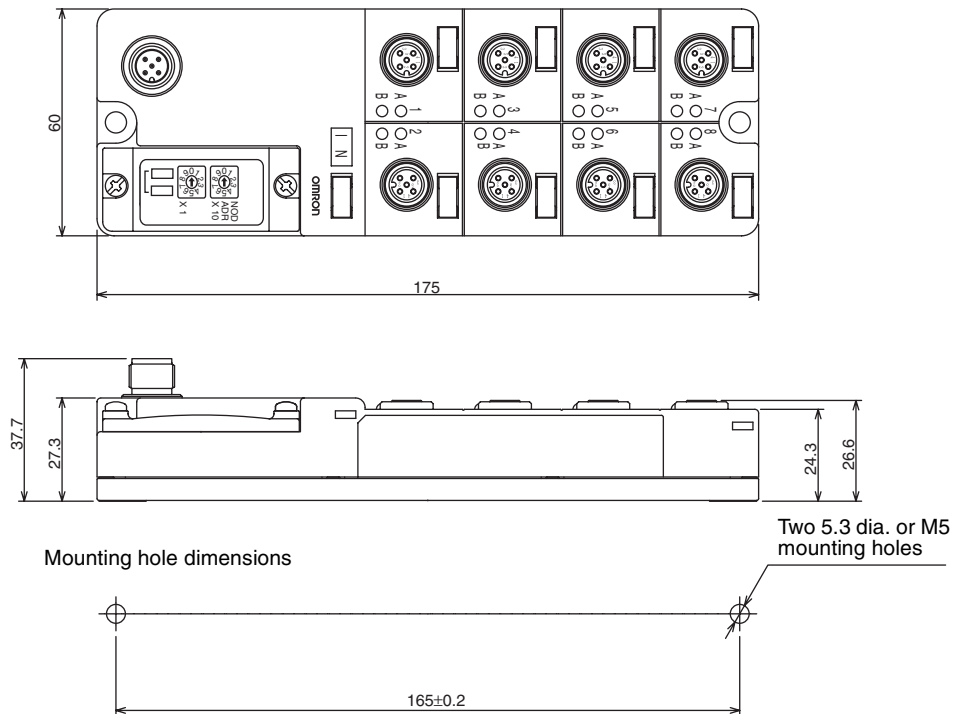

## 6-4-4 Environment-resistive Terminals with 8 Transistor Outputs (IP67): DRT2-OD08C (NPN) and DRT2-OD08C-1 (PNP)

### Output Specifications

Item	Specifications	
Model	DRT2-OD08C	DRT2-OD08C-1
Internal I/O common	NPN	PNP
Output points	8 points	
Rated output current	1.5 A/point, 8.0 A/common	
I/O power supply voltage	20.4 to 26.4 V DC (24 V DC, -15 to +10%)	
Residual voltage	1.2 V max. (at 1.5 A between each output terminal and G)	1.2 V max. (at 1.5 A between each output terminal and V)
Leakage current	0.1 mA max.	
ON delay time	0.5 ms max.	
OFF delay time	1.5 ms max.	
Number of circuits	8 points with one common	

### Status Indicators

#### I/O Status Indicators

The I/O status indicator displays and their meanings are shown in the following table. Refer to the following section on names of components and functions for details on the location of the I/O status indicators. In the indicator name "1-A," the "1" indicates the connector number, and the "A" indicates that it is an I/O status indicator.

Indicator	Color	Status	Meaning
1-A	Yellow	ON	Output 0 is ON.
1-B	Red	ON	The load of output 0 has shorted.
2-A	Yellow	ON	Output 1 is ON.
2-B	Red	ON	The load of output 1 has shorted.
3-A	Yellow	ON	Output 2 is ON.
3-B	Red	ON	The load of output 2 has shorted.
4-A	Yellow	ON	Output 3 is ON.
4-B	Red	ON	The load of output 3 has shorted.
5-A	Yellow	ON	Output 4 is ON.
5-B	Red	ON	The load of output 4 has shorted.
6-A	Yellow	ON	Output 5 is ON.
6-B	Red	ON	The load of output 5 has shorted.
7-A	Yellow	ON	Output 6 is ON.
7-B	Red	ON	The load of output 6 has shorted.
8-A	Yellow	ON	Output 7 is ON.
8-B	Red	ON	The load of output 7 has shorted.

**Note** Although the connectors are numbered from 1 to 8, the input bits are numbered from 0 to 7. (The inputs are also numbered from 0 to 7 in the Configurator displays.)

#### I/O Power Supply Status Indicator

Indicator	Color	Status	Meaning
AUX PWR	Green	ON	I/O power is being supplied.



**Component Names and Functions: DRT2-OD08C and DRT2-OD08C-1**

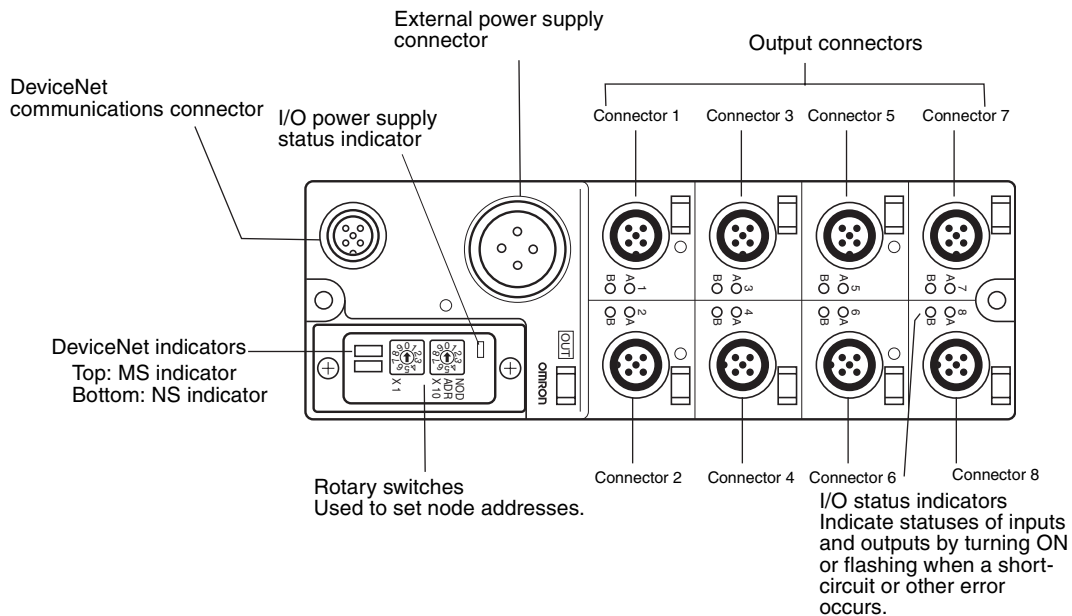

**Internal Circuits**

**DRT2-OD08C (NPN)**

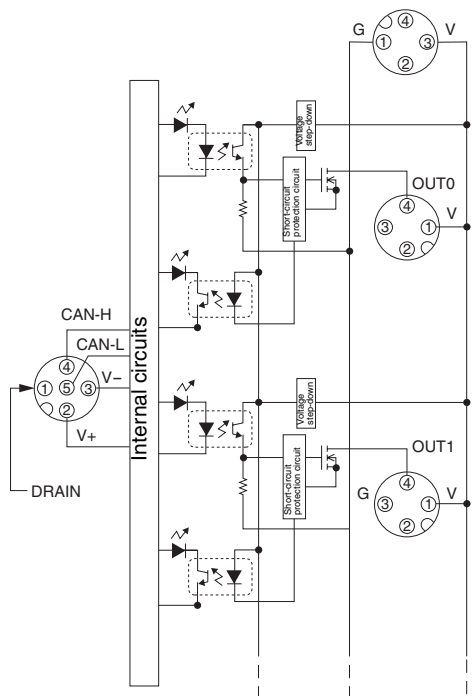

DRT2-OD08C-1 (PNP)

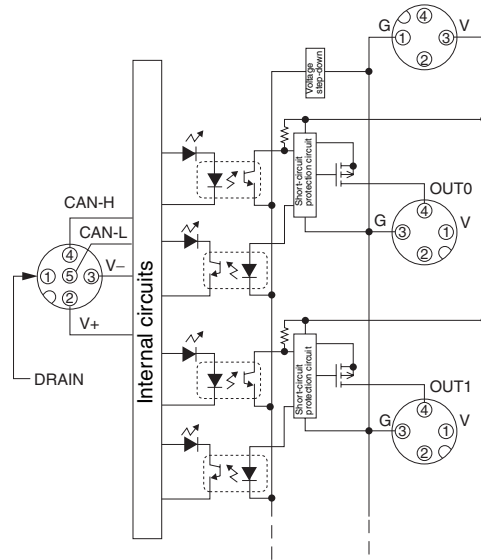

Wiring

DRT2-OD08C (NPN)

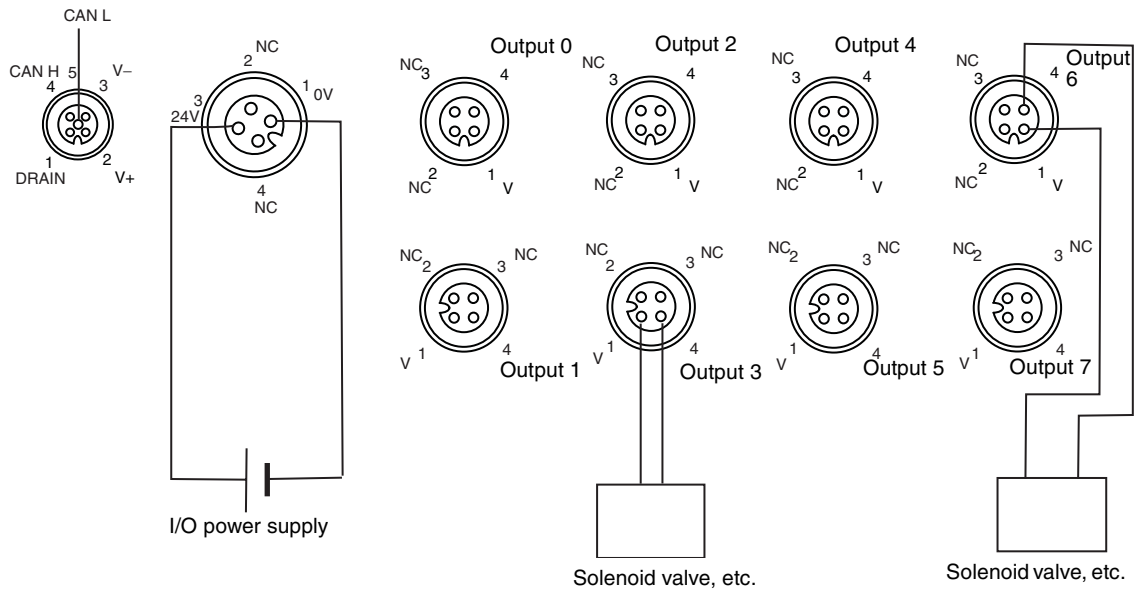

**Note** Power cannot be supplied to output devices from output connector G. Supply power to output devices externally.

DRT2-OD08C-1 (PNP)

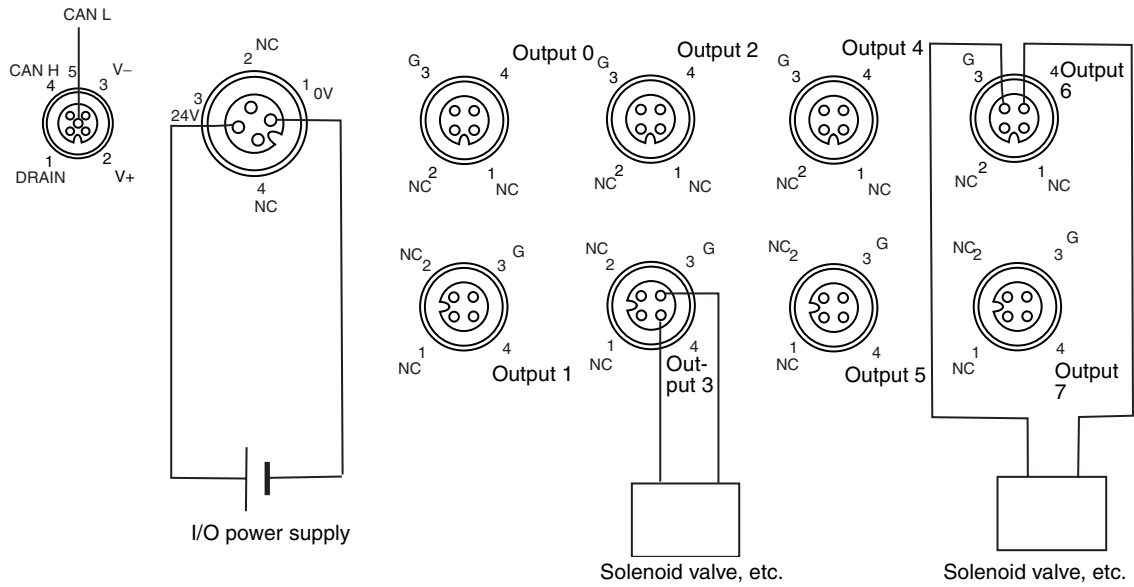

**Note** Power cannot be supplied to output devices from output connector V. Supply power to output devices externally.

**Dimensions: DRT2-OD08C and DRT2-OD08C-1**

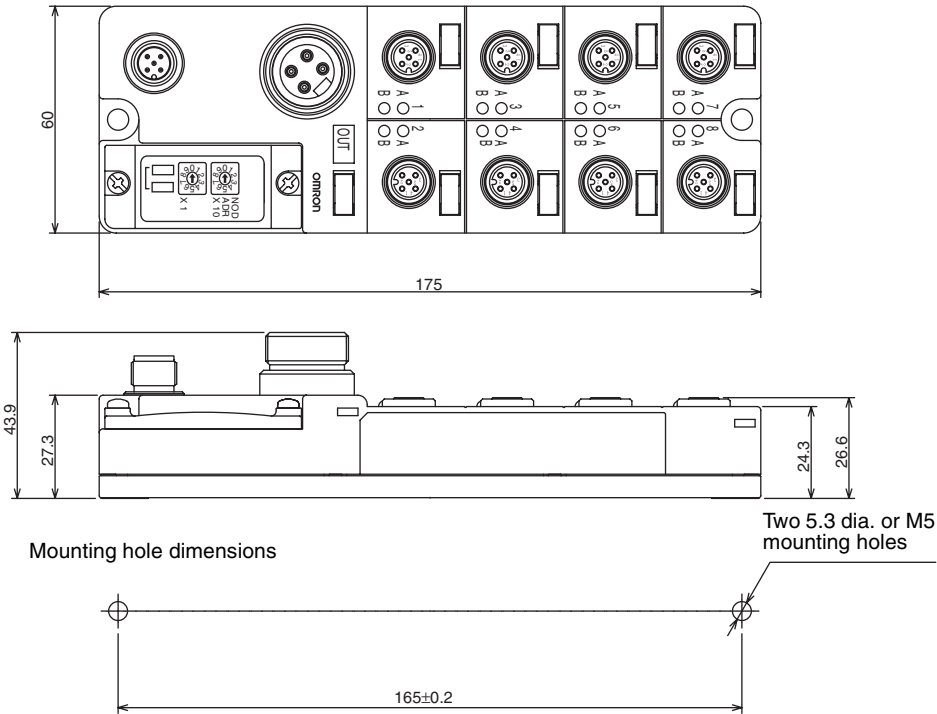

**Load Short-circuit Protection: DRT2-OD08C and DRT2-OD08C-1**

Normally, when the output contact (OUT) turns ON, the transistor turns ON, and output current (I<sub>out</sub>) flows, as shown in Fig. 1.

If the current limit (I<sub>lim</sub>) is exceeded when there is an overload in the output current (I<sub>out</sub>) or when a load short-circuit occurs, as shown in Fig. 2 and 3, the output current (I<sub>out</sub>) will be limited. Then, if the output transistor junction temperature (T<sub>j</sub>) reaches the thermal shutdown temperature (T<sub>std</sub>), the output will

be turned OFF to prevent damage to the transistor, the Load Shorted Flag will be turned ON, and the indicator will light red.

In automatic recovery mode (Fig. 2), the short-circuit protection status will be automatically cleared and the output current will start to flow again when the transistor's shutdown temperature ( $T_j$ ) drops to the reset temperature ( $T_r$ ).

In manual recovery mode (Fig. 3), the short-circuit protection status will be held even when the transistor's shutdown temperature ( $T_j$ ) drops to the reset temperature ( $T_r$ ), and recovery will occur when the Unit is reset by turning OFF the I/O power supply or the Unit's power supply.

**Fig. 1 Normal Operation**

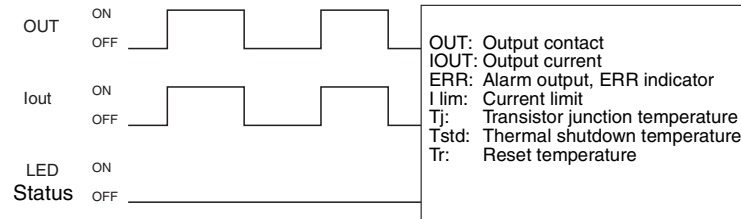

**Fig. 2 Overload or Short-circuit (Automatic Recovery Mode)**

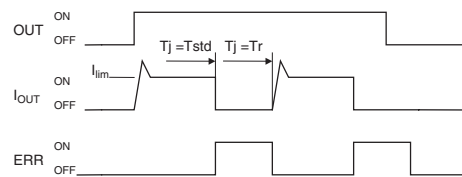

**Fig. 3 Overload or Short-circuit (Manual Recovery Mode)**

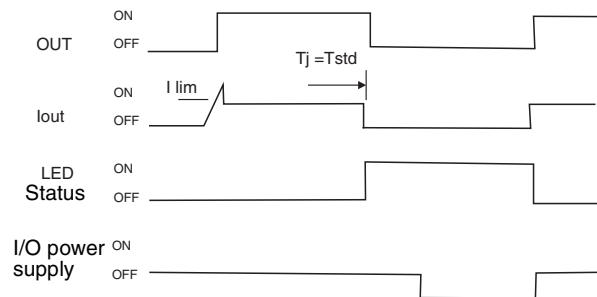

**Automatic Recovery Mode Restrictions**

The Unit has load short-circuit protection, but automatic recovery mode is designed to protect the internal circuits specifically from a brief load short-circuit.

In automatic recovery mode, the Unit's load short-circuit protection is automatically cleared when  $T_j = T_r$ , as shown in Fig. 2. Therefore, as long as the cause of the short-circuit is not removed, the output's ON/OFF operation will repeat.

If the Unit is left with a short circuit, the internal temperature will rise, causing damage to the Unit. Always remove the cause of an external load short-circuit promptly.

**Note** When an external load short-circuit is detected, the External Load Shorted Flag will turn ON in the Unit's Status Area and the indicator corresponding to the shorted output contact will turn ON. An OR for all contact status will output to the Short-circuited Flag.

When the Load Shorted Flag turns ON, either hold the status of the bit in the user program and program to turn OFF all the Unit's outputs, or use an Explicit message to read the contact that is shorted and turn it OFF. The Short-circuited Flag is allocated in the fifth bit in the Unit's status information area.



**Programming Example**

In the following programming example, output bits 00 to 07 of CIO 3200 turn OFF when bit 05 of CIO 3300 (Load Shorted Flag) turns ON once. Output bits 00 to 07 of CIO 3200 will not turn ON again until the cause of the short is removed and the outputs are reset by turning ON work bit W00001.

Setting Status

DRT2-OD08C

Node address 00, I/O allocated to CIO 3200, status allocated to CIO 3300.

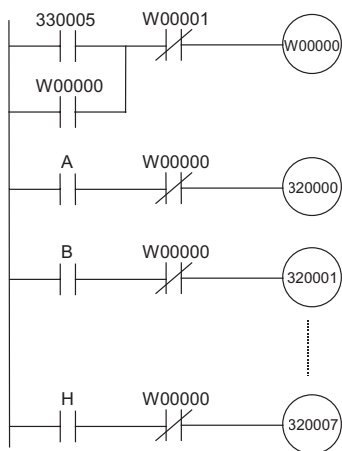

## 6-5 Standard Environment-resistive Terminals

### 6-5-1 Node Address, Baud Rate, and Output Hold/Clear Settings

This section describes the Environment-resistive Terminal's node address setting, baud rate settings, and hold/clear outputs for communications error setting. These settings are made as follows:

Node address setting: Rotary switches

Baud rate setting: Automatic follow-up

Output hold/clear setting: Software switch

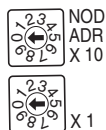

**Node Address Settings**

The node address of the Environment-resistive Terminal is set as a decimal, using the top rotary switch for the ten's digit, and the bottom rotary switch for the one's digit.

Any node address within the setting range can be used as long as it is not already set for another node.

Refer to *SECTION 5 General-purpose Slaves* for details on setting from the Configurator.

- Note**
1. Setting the same node address for more than one node will cause a node address duplication error and communications will not start.
  2. Always turn OFF the power (including the communications power supply) to the Slave before setting.

**Baud Rate Setting**

The baud rate of the whole system is determined by the baud rate set for the Master Unit. Setting the baud rate for each Unit is not required.

**Output Hold/Clear Setting**

Use the Configurator to set the output hold/clear settings. The factory setting is for outputs to be cleared. Refer to *SECTION 5 General-purpose Slaves* for setting details.

## 6-5-2 Environment-resistive Terminals with 4 Transistor Inputs (IP67): DRT2-ID04CL (NPN) and DRT2-ID04CL-1 (PNP)

**Input Specifications**

Item	Specifications	
Model	DRT2-ID04CL	DRT2-ID04CL-1
Internal I/O common	NPN	PNP
Input points	4 points	
ON voltage	15 V DC min. (between each input terminal and V)	15 V DC min. (between each input terminal and G)
OFF voltage	5 V DC max. (between each input terminal and V)	5 V DC max. (between each input terminal and G)
OFF current	1 mA max.	
Input current	6.0 mA max./point (for 24 V DC), 3.0 mA min./point (for 17 V DC)	
I/O power supply voltage	20.4 to 26.4 V DC (24 V DC, -15 to +10%)	
ON delay time	1.5 ms max.	
OFF delay time	1.5 ms max.	
Number of circuits	4 points with one common	

**Indicators****I/O Status Indicators**

The I/O status indicator displays and their meanings are shown in the following table. Refer to the section following on names of components and functions for details on the location of the I/O status indicators. In the indicator name "1-A," the "1" indicates the connector number, and the "A" indicates that it is an I/O status indicator.

Indicator	Color	Status	Meaning
1-A	Yellow	ON	Input 0 is ON.
2-A	Yellow	ON	Input 1 is ON.
3-A	Yellow	ON	Input 2 is ON.
4-A	Yellow	ON	Input 3 is ON.

- Note**
1. The I/O status indicator “B” is not used by Units with 4 inputs.
  2. Although the connectors are numbered from 1 to 4, the input bits are numbered from 0 to 3. (The input bits are also numbered from 0 to 7 in the Configurator display.)

**I/O Power Supply Indicator**

Indicator	Color	Status	Meaning
AUX PWR	Green	ON	I/O power is being supplied.

**Component Names and Functions: DRT2-ID04CL and DRT2-ID04CL-1**

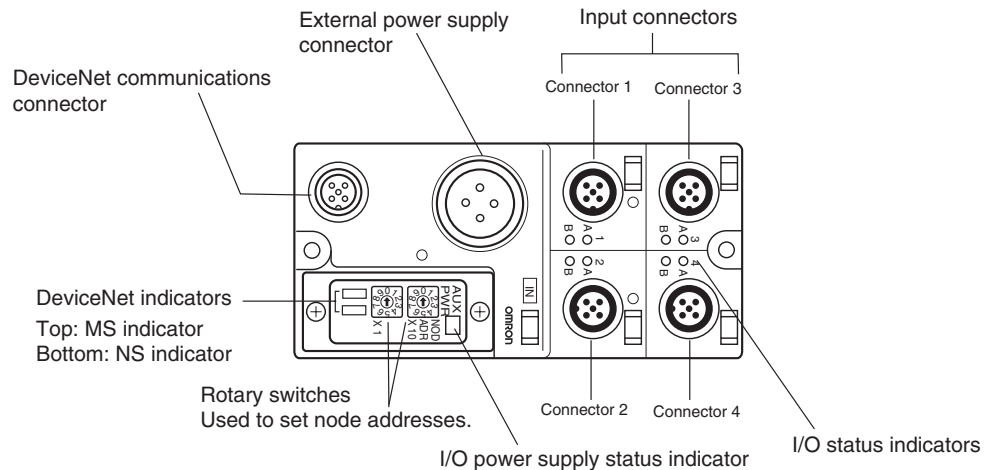

**Internal Circuits**

**DRT2-ID04CL (NPN)**

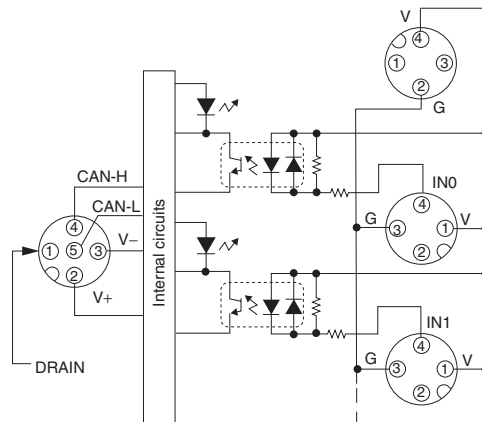

DRT2-ID04CL-1 (PNP)

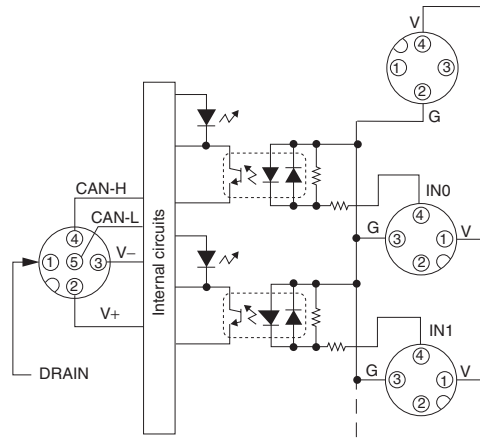

**Wiring**

DRT2-ID04CL (NPN)

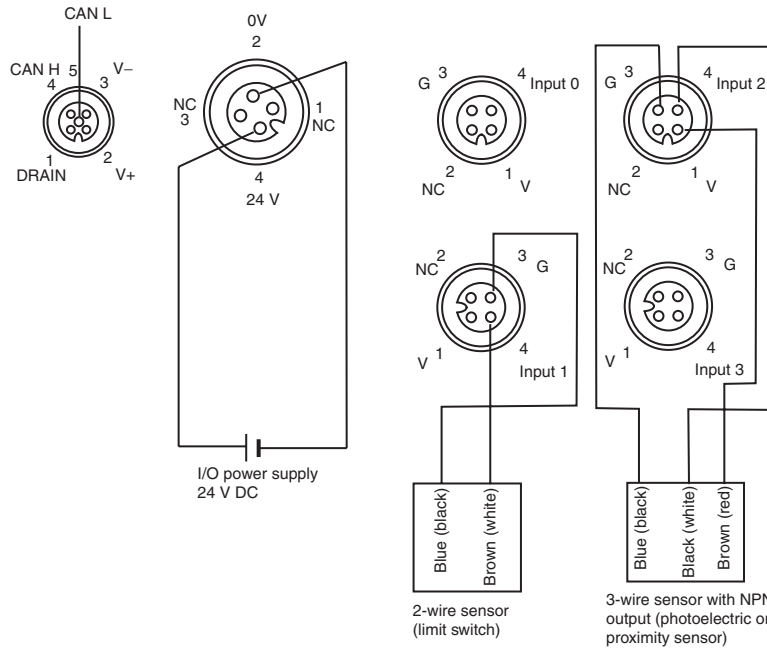



DRT2-ID04CL-1 (PNP)

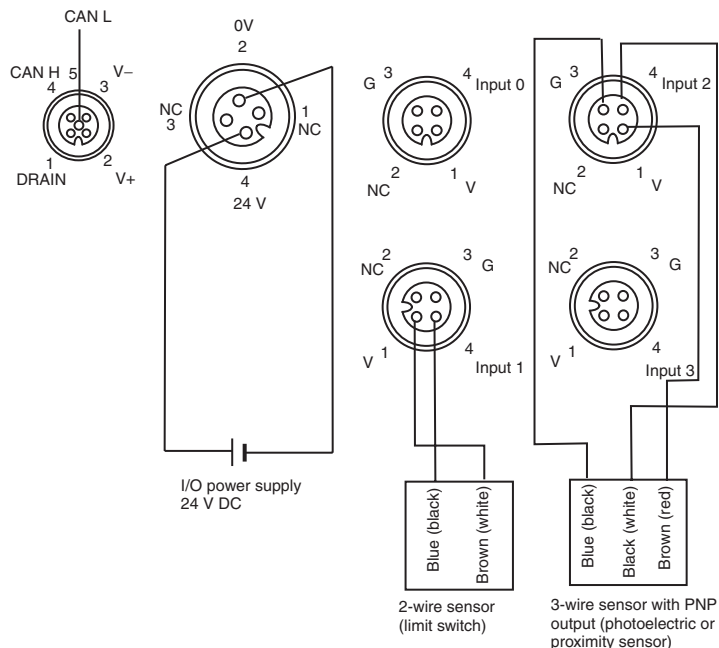

**Note** Wire colors in parentheses are the previous JIS colors for photoelectric and proximity sensors.

**Dimensions: DRT2-ID04CL and DRT2-ID04CL-1**

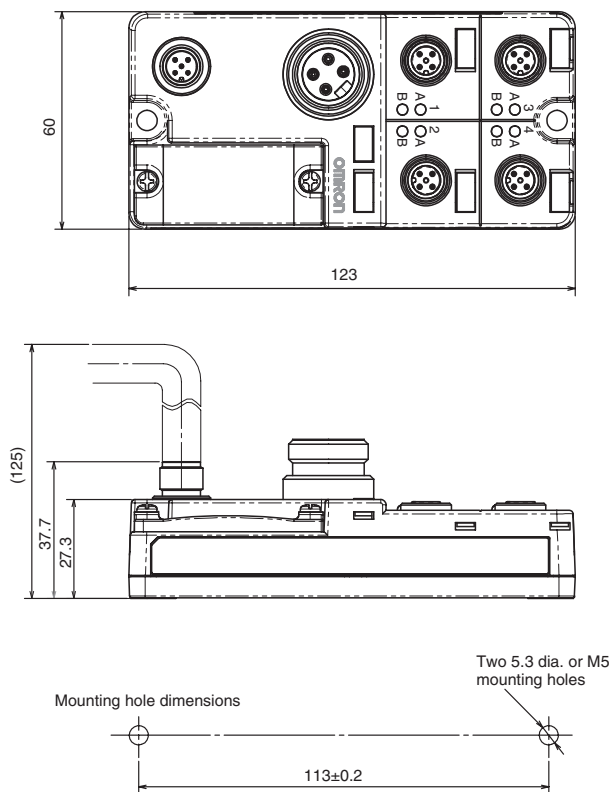

### 6-5-3 Environment-resistive Terminals with 8 Transistor Inputs (IP67): DRT2-ID08CL (NPN) and DRT2-ID08CL-1 (PNP)

#### Input Specifications

Item	Specifications	
Model	DRT2-ID08CL	DRT2-ID08CL-1
Internal I/O common	NPN	PNP
Input points	8 points	
ON voltage	15 V DC min. (between each input terminal and V)	15 V DC min. (between each input terminal and G)
OFF voltage	5 V DC max. (between each input terminal and V)	5 V DC max. (between each input terminal and G)
OFF current	1 mA max.	
Input current	6.0 mA max./point (for 24 V DC), 3.0 mA min./point (for 17 V DC)	
I/O power supply voltage	20.4 to 26.4 V DC (24 V DC, -15 to +10%)	
ON delay time	1.5 ms max.	
OFF delay time	1.5 ms max.	
Number of circuits	8 points with one common	

#### Indicators

##### I/O Status Indicators

The I/O status indicator displays and their meanings are shown in the following table. Refer to the section following on names of components and functions for details on the location of the I/O status indicators. In the indicator name "1-A," the "1" indicates the connector number, and the "A" indicates that it is an I/O status indicator.

Indicator	Color	Status	Meaning
1-A	Yellow	ON	Input 0 is ON.
2-A	Yellow	ON	Input 1 is ON.
3-A	Yellow	ON	Input 2 is ON.
4-A	Yellow	ON	Input 3 is ON.
5-A	Yellow	ON	Input 4 is ON.
6-A	Yellow	ON	Input 5 is ON.
7-A	Yellow	ON	Input 6 is ON.
8-A	Yellow	ON	Input 7 is ON.

- Note**
1. The I/O status indicator "B" is not used by Units with 8 inputs.
  2. Although the connectors are numbered from 1 to 8, the input bits are numbered from 0 to 7. (The input bits are also numbered from 0 to 7 in the Configurator display.)

##### I/O Power Supply Status Indicator

Indicator	Color	Status	Meaning
AUX PWR	Green	ON	I/O power is being supplied.

Component Names and Functions: DRT2-ID08CL and DRT2-ID08CL-1

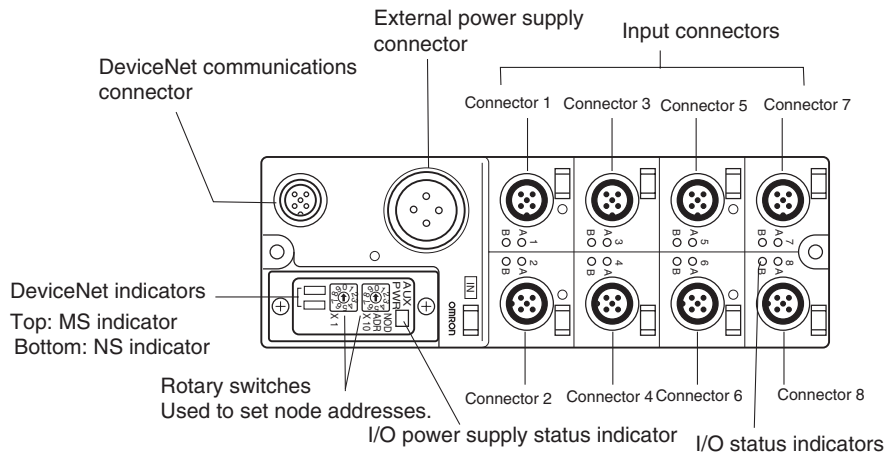

**Internal Circuits**

**DRT2-ID08CL (NPN)**

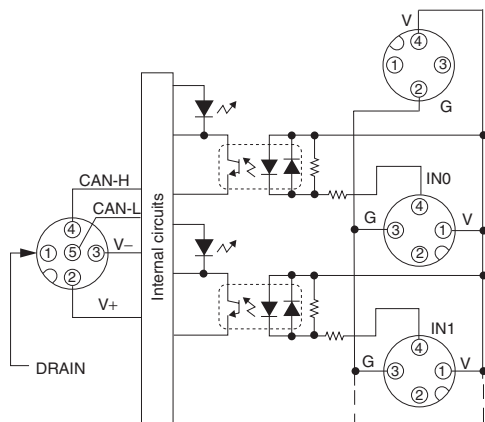

**DRT2-ID08CL-1 (PNP)**

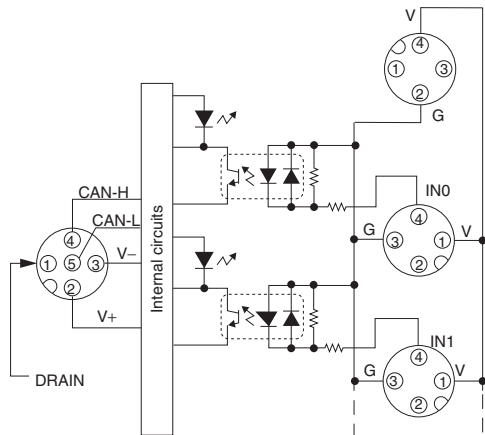

**Wiring**

**DRT2-ID08CL (NPN)**

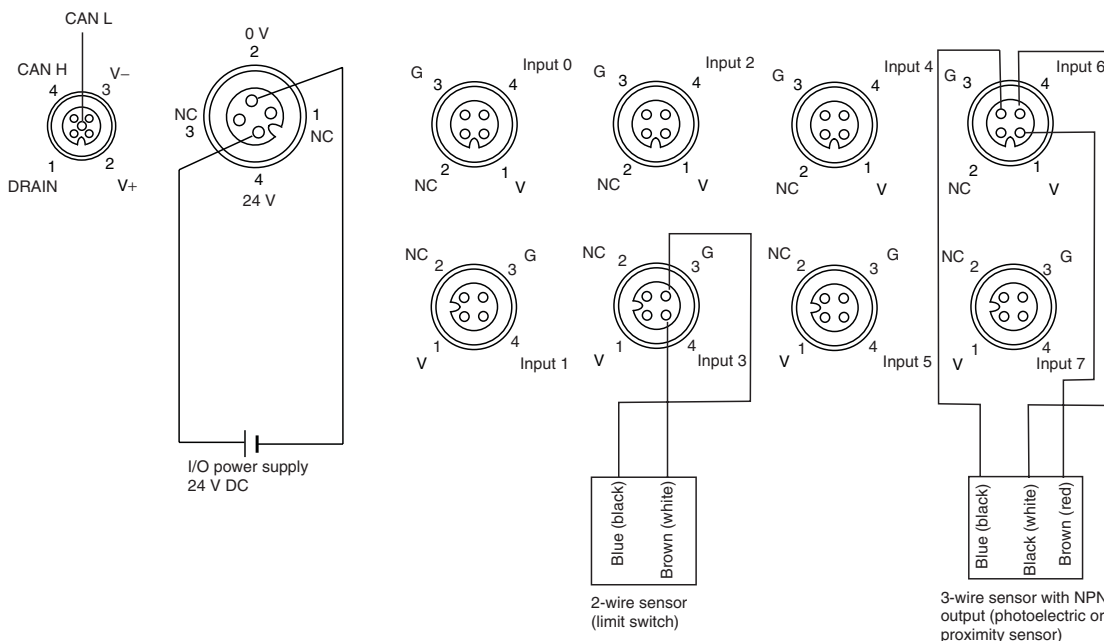

**DRT2-ID08CL-1 (PNP)**

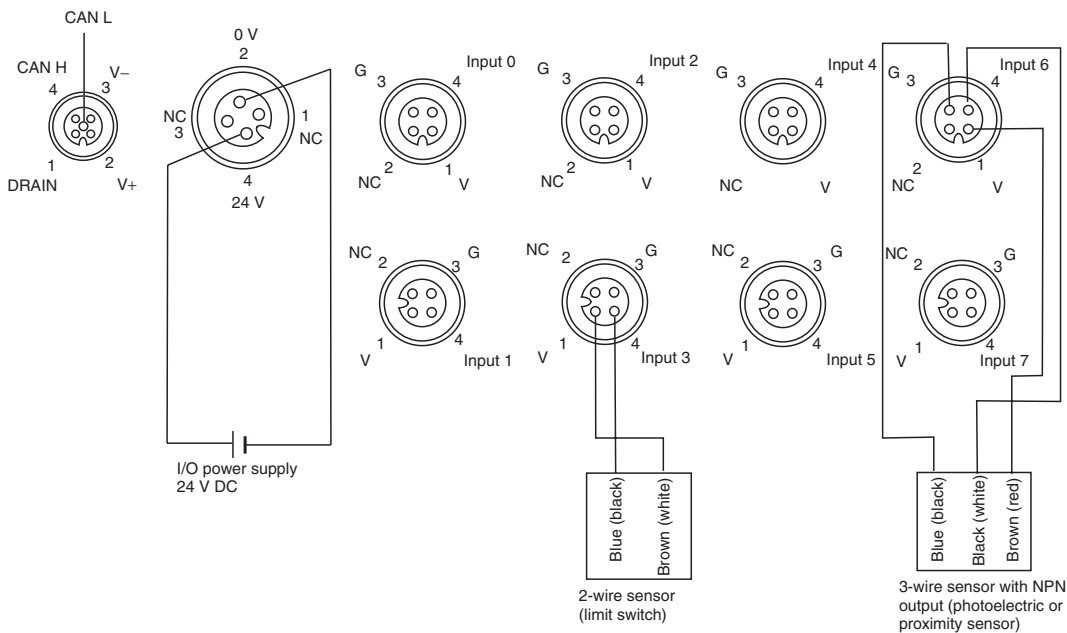

**Note** Wire colors in parentheses are the previous JIS colors for photoelectric and proximity sensors.

**Dimensions: DRT2-ID08CL and DRT2-ID08CL-1**

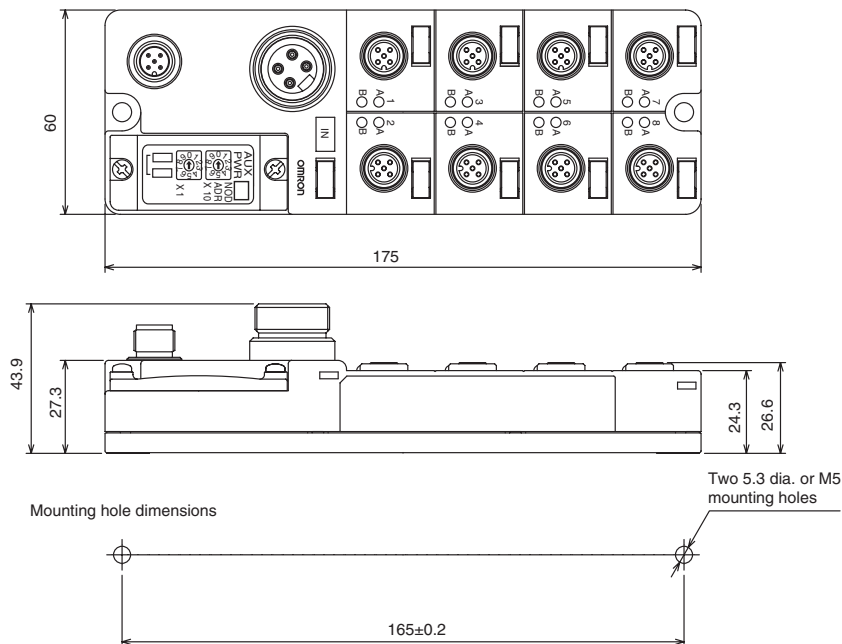

**6-5-4 Environment-resistive Terminals with 16 Transistor Inputs (IP67): DRT2-HD16CL (NPN) and DRT2-HD16CL-1 (PNP)**

**Input Specifications**

Item	Specifications	
Model	DRT2-HD16CL	DRT2-HD16CL-1
Internal I/O common	NPN	PNP
Input points	16 points	
ON voltage	15 V DC min. (between each input terminal and V)	15 V DC min. (between each input terminal and G)
OFF voltage	5 V DC max. (between each input terminal and V)	5 V DC max. (between each input terminal and G)
OFF current	1 mA max.	
Input current	6.0 mA max./point (for 24 V DC), 3.0 mA min./point (for 17 V DC)	
I/O power supply voltage	20.4 to 26.4 V DC (24 V DC, -15 to +10%)	
ON delay time	1.5 ms max.	
OFF delay time	1.5 ms max.	
Number of circuits	16 points with one common	

**Indicators**

**I/O Status Indicators**

The I/O status indicator displays and their meanings are shown in the following table. Refer to the section following on names of components and functions for details on the location of the I/O status indicators. In the indicator

name “1-A,” the “1” indicates the connector number, and the “A” indicates that it is an I/O status indicator.

Indicator	Color	Status	Meaning
1-A	Yellow	ON	Input 0 is ON.
1-B	Yellow	ON	Input 1 is ON.
2-A	Yellow	ON	Input 2 is ON.
2-B	Yellow	ON	Input 3 is ON.
3-A	Yellow	ON	Input 4 is ON.
3-B	Yellow	ON	Input 5 is ON.
4-A	Yellow	ON	Input 6 is ON.
4-B	Yellow	ON	Input 7 is ON.
5-A	Yellow	ON	Input 8 is ON.
5-B	Yellow	ON	Input 9 is ON.
6-A	Yellow	ON	Input 10 is ON.
6-B	Yellow	ON	Input 11 is ON.
7-A	Yellow	ON	Input 12 is ON.
7-B	Yellow	ON	Input 13 is ON.
8-A	Yellow	ON	Input 14 is ON.
8-B	Yellow	ON	Input 15 is ON.

**Note** Although the connectors are numbered from 1 to 8, the input bits are numbered from 0 to 7. (The input bits are also numbered from 0 to 7 in the Configurator display.)

**I/O Power Supply Status Indicator**

Indicator	Color	Status	Meaning
AUX PWR	Green	ON	I/O power is being supplied.

**Component Names and Functions: DRT2-HD16CL and DRT2-HD16CL-1**

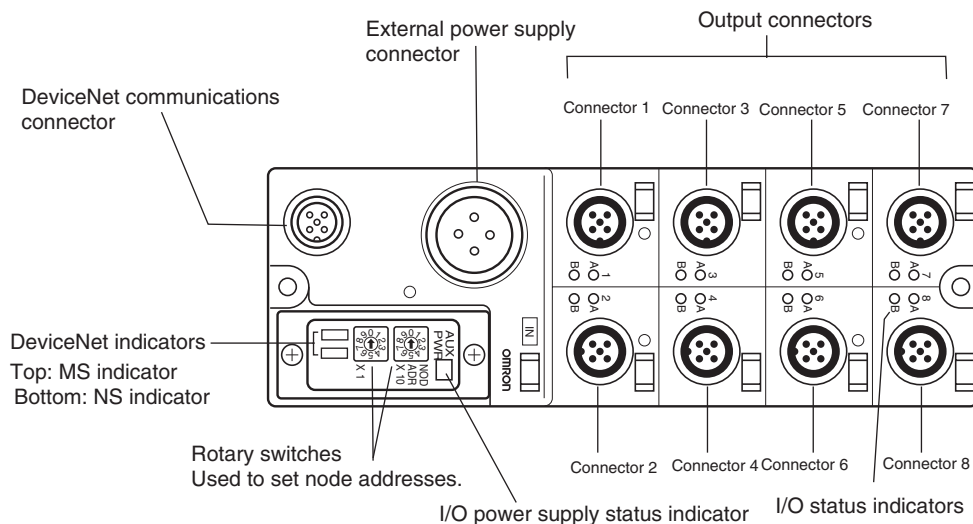

**Internal Circuits**

**DRT2-HD16CL (NPN)**

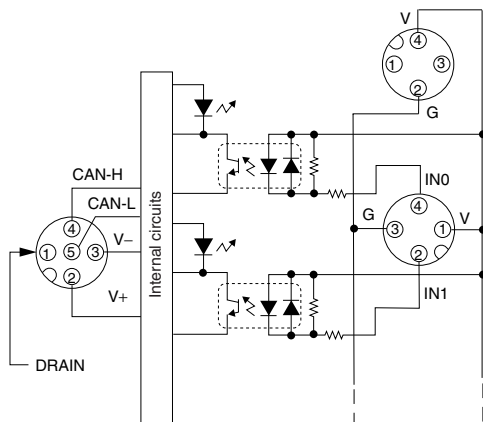

**DRT2-HD16CL-1 (PNP)**

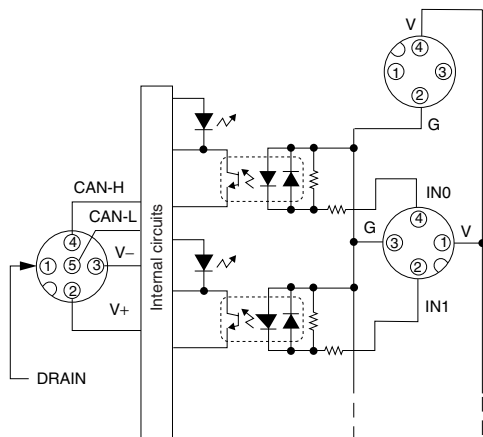

**Wiring**

**DRT2-HD16CL (NPN)**

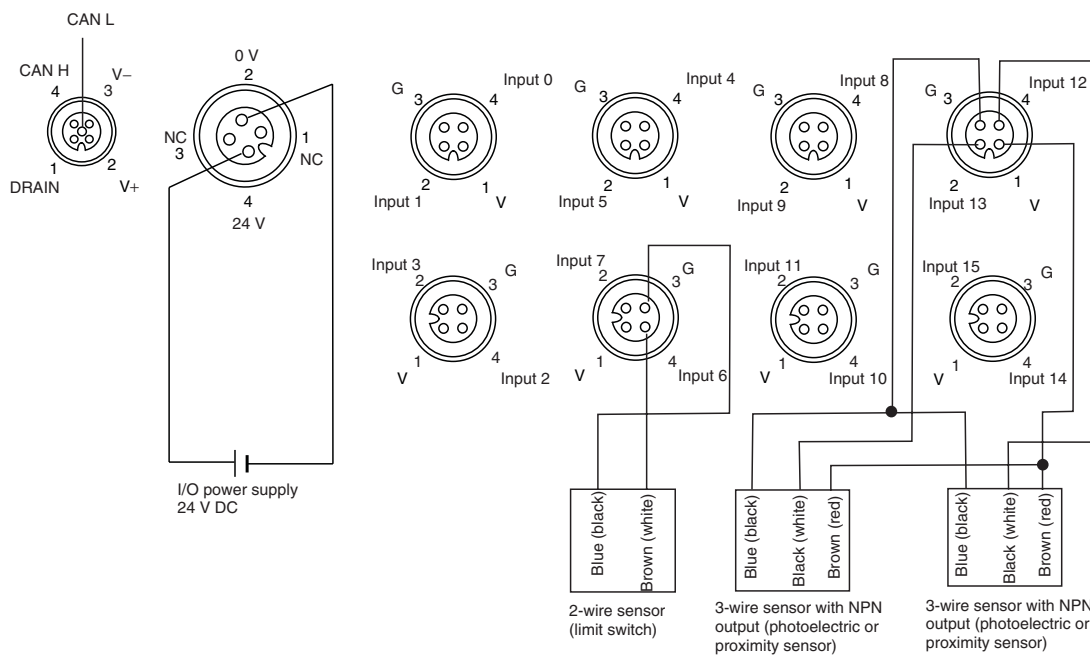

**DRT2-HD16CL-1 (PNP)**

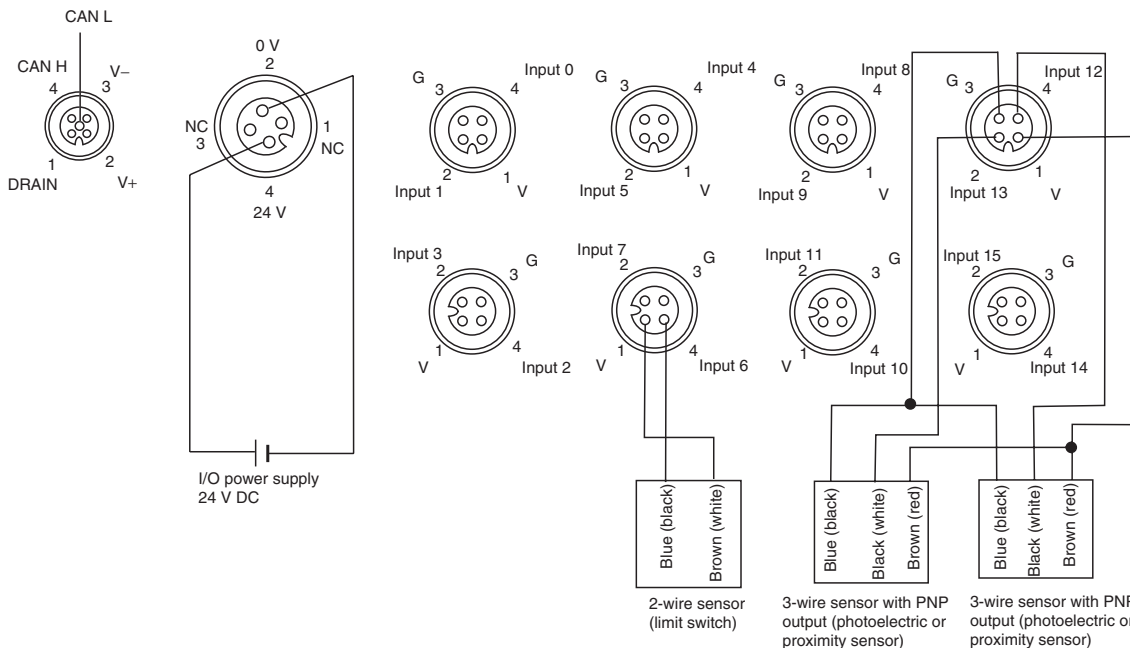

**Note** Wire colors in parentheses are the previous JIS colors for photoelectric and proximity sensors.

**Dimensions: DRT2-HD16CL and DRT2-HD16CL-1**

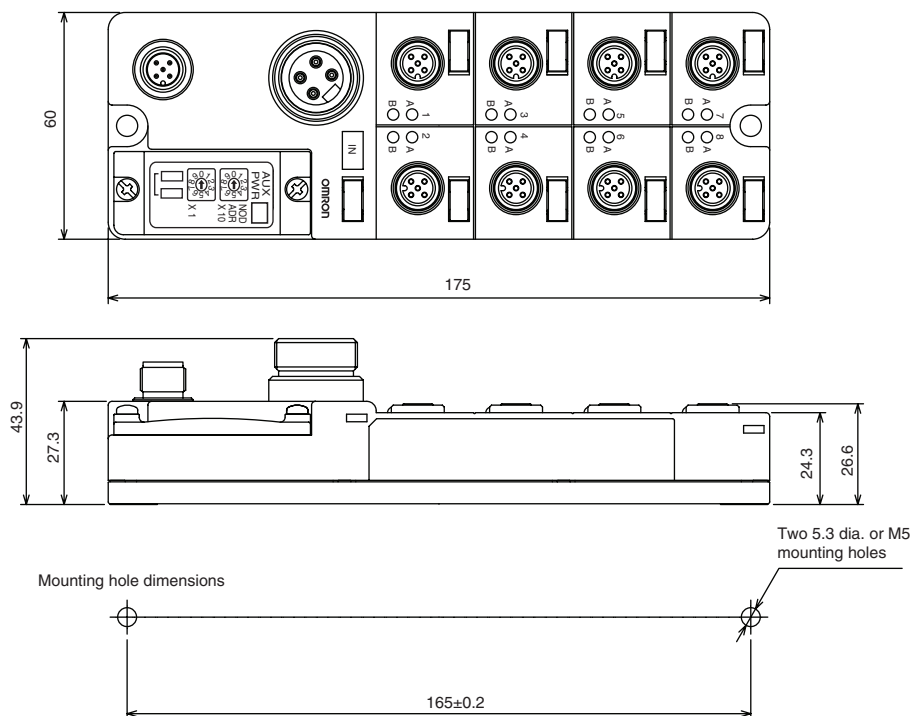



### 6-5-5 Environment-resistive Terminals with 4 Transistor Outputs (IP67): DRT2-OD04CL (NPN) and DRT2-OD04CL-1 (PNP)

#### Output Specifications

Item	Specifications	
Model	DRT2-OD04CL	DRT2-OD04CL-1
Internal I/O common	NPN	PNP
Output points	4 points	
Rated output current	0.5 A/point, 2.0 A/common	
I/O power supply voltage	20.4 to 26.4 V DC (24 V DC, -15 to +10%)	
Residual voltage	1.2 V max. (0.5 A DC, between each output terminal and G)	1.2 V max. (0.5 A DC, between each output terminal and V)
Leakage current	0.1 mA max.	
ON delay time	0.5 ms max.	
OFF delay time	1.5 ms max.	
Number of circuits	4 points with one common	

#### Indicators

##### I/O Status Indicators

The I/O status indicator displays and their meanings are shown in the following table. Refer to the section following on names of components and functions for details on the location of the I/O status indicators. In the indicator name "1-A," the "1" indicates the connector number, and the "A" indicates that it is an I/O status indicator.

Indicator	Color	Status	Meaning
1-A	Yellow	ON	Output 0 is ON.
2-A	Yellow	ON	Output 1 is ON.
3-A	Yellow	ON	Output 2 is ON.
4-A	Yellow	ON	Output 3 is ON.

**Note** Although the connectors are numbered from 1 to 4, the input bits are numbered from 0 to 3.

##### I/O Power Supply Status Indicator

Indicator	Color	Status	Meaning
AUX PWR	Green	ON	I/O power is being supplied.

**Component Names and Functions: DRT2-OD04CL and DRT2-OD04CL-1**

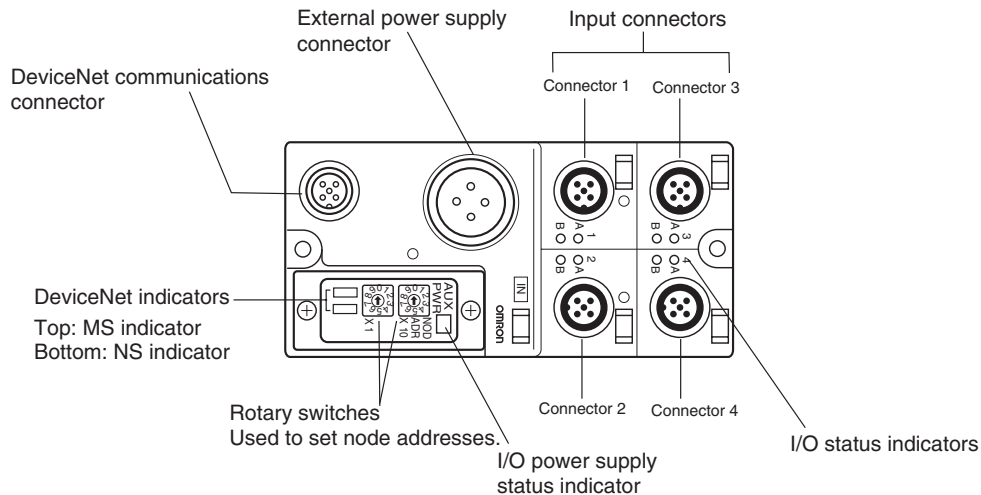

**Internal Circuits**

**DRT2-OD04CL (NPN)**

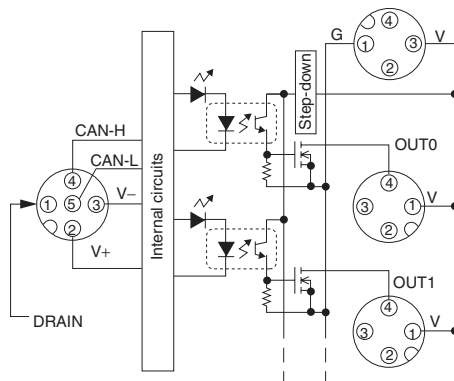

**DRT2-ID04CL-1 (PNP)**

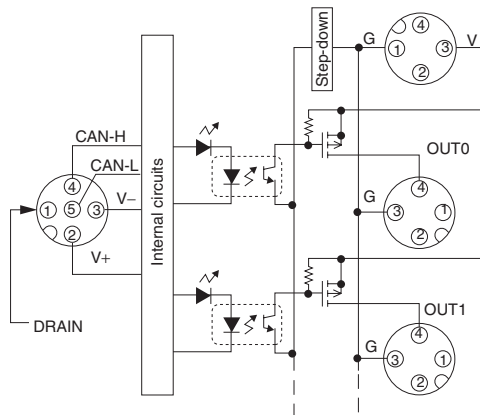

**Wiring**

**DRT2-OD04CL (NPN)**

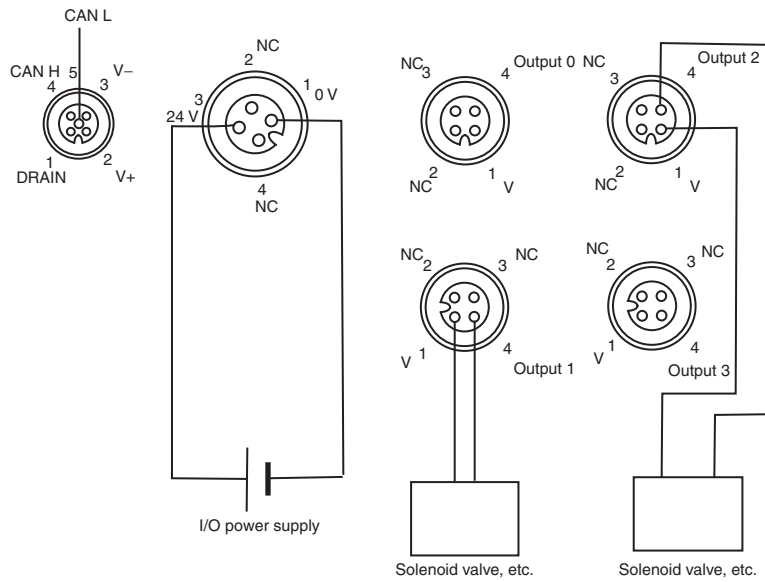

**DRT2-OD04CL-1 (PNP)**

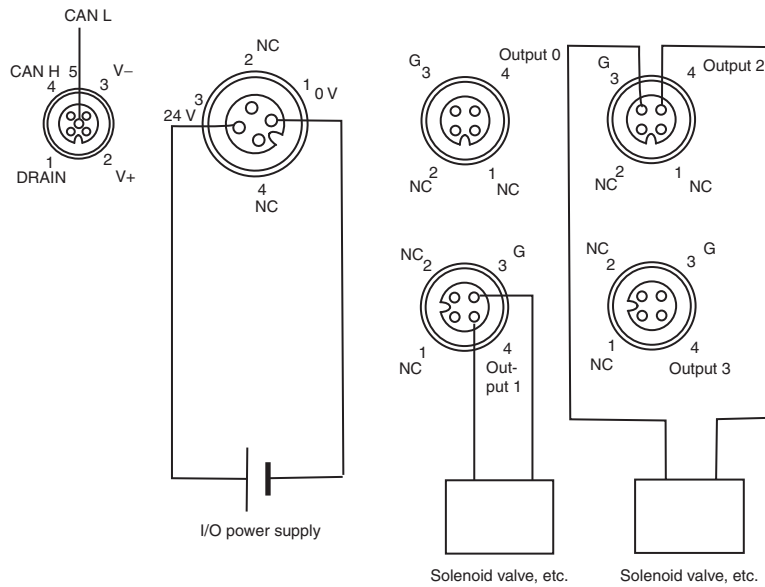

**Dimensions: DRT2-OD04CL and DRT2-OD04CL-1**

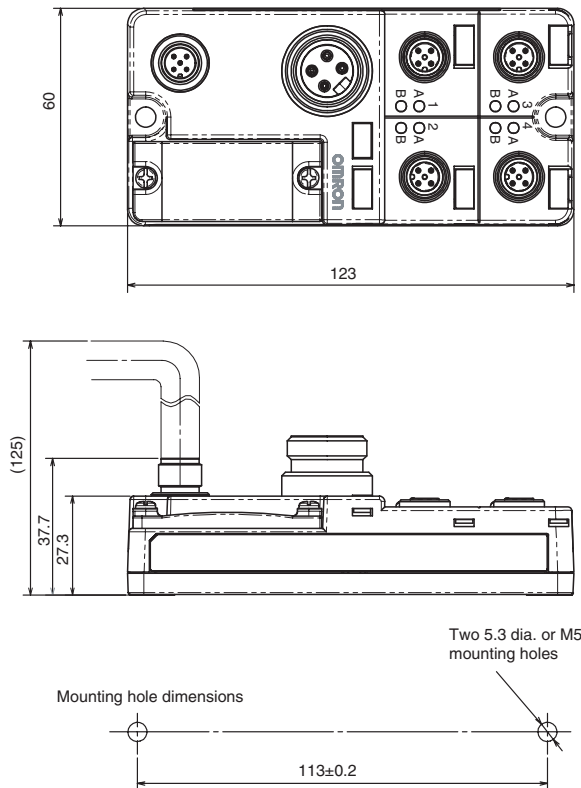

**6-5-6 Environment-resistive Terminals with 8 Transistor Outputs (IP67): DRT2-OD08CL (NPN) and DRT2-OD08CL-1 (PNP)**

**Output Specifications**

Item	Specifications	
Model	DRT2-OD08CL	DRT2-OD08CL-1
Internal I/O common	NPN	PNP
Output points	8 points	
Rated output voltage	0.5 A/point, 4.0 A/common	
I/O power supply voltage	20.4 to 26.4 V DC (24 V DC, -15 to +10%)	
Residual voltage	1.2 V max. (0.5 A DC, between each output terminal and G)	1.2 V max. (0.5 A DC, between each output terminal and V)
Leakage current	0.1 mA max.	
ON delay time	0.5 ms max.	
OFF delay time	1.5 ms max.	
Number of circuits	8 points with one common	

**Indicators**

**I/O Status Indicators**

The I/O status indicator displays and their meanings are shown in the following table. Refer to the section following on names of components and functions for details on the location of the I/O status indicators. In the indicator

name “1-A,” the “1” indicates the connector number, and the “A” indicates that it is an I/O status indicator.

Indicator	Color	Status	Meaning
1-A	Yellow	ON	Output 0 is ON.
2-A	Yellow	ON	Output 1 is ON.
3-A	Yellow	ON	Output 2 is ON.
4-A	Yellow	ON	Output 3 is ON.
5-A	Yellow	ON	Output 4 is ON.
6-A	Yellow	ON	Output 5 is ON.
7-A	Yellow	ON	Output 6 is ON.
8-A	Yellow	ON	Output 7 is ON.

**Note** Although the connectors are numbered from 1 to 8, the input bits are numbered from 0 to 7.

**I/O Power Supply Status Indicator**

Indicator	Color	Status	Meaning
AUX PWR	Green	ON	I/O power is being supplied.

**Component Names and Functions: DRT2-OD08CL and DRT2-OD08CL-1**

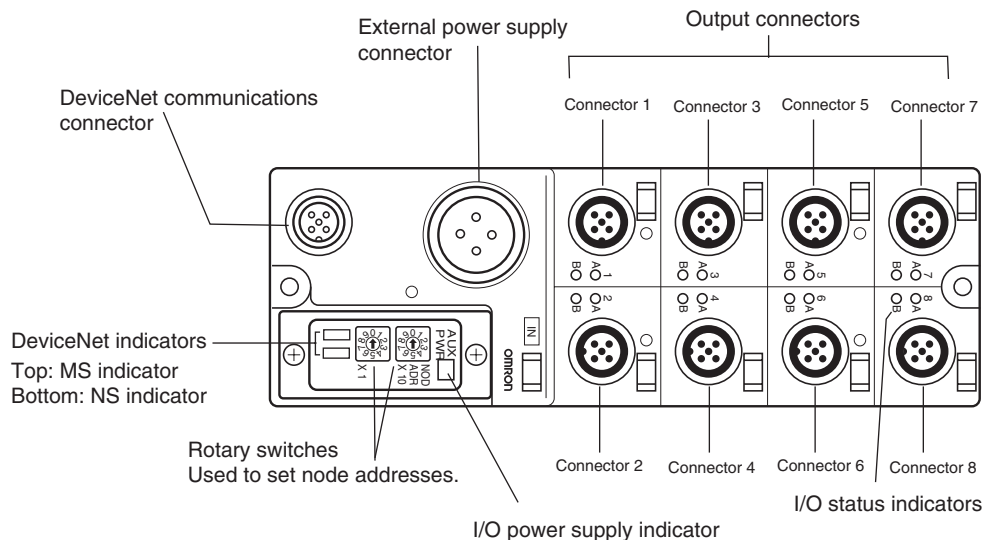

**Internal Circuits**

**DRT2-OD08CL (NPN)**

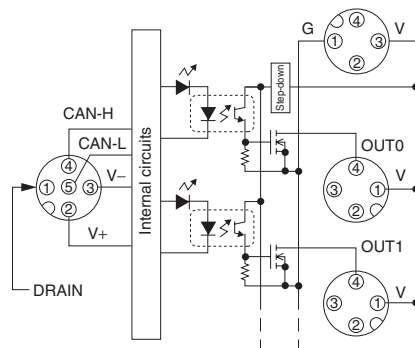

DRT2-OD08CL-1 (PNP)

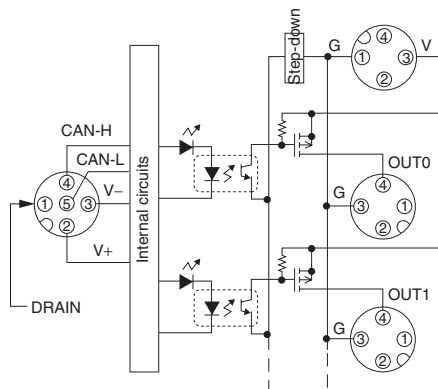

Wiring

DRT2-OD08CL (NPN)

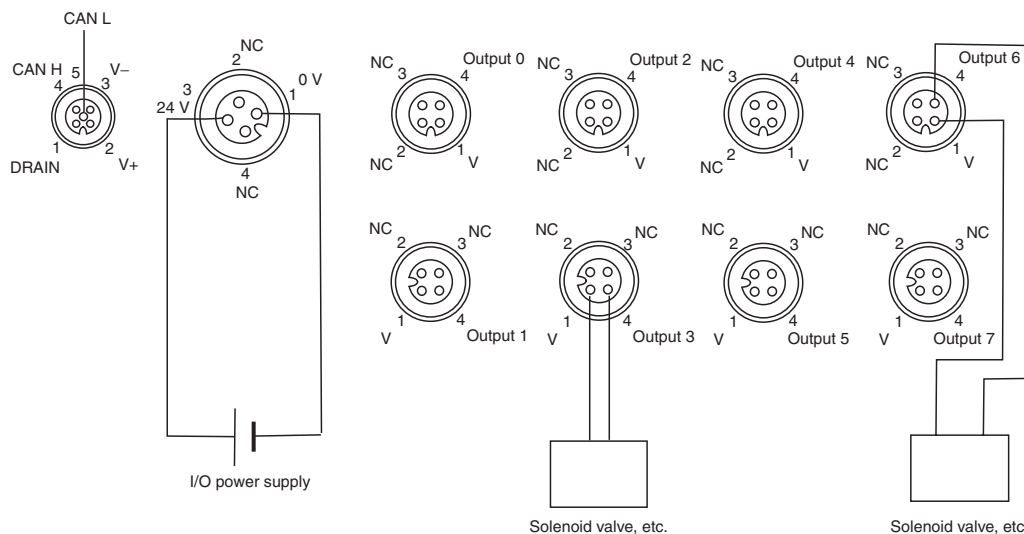

DRT2-OD08CL-1 (PNP)

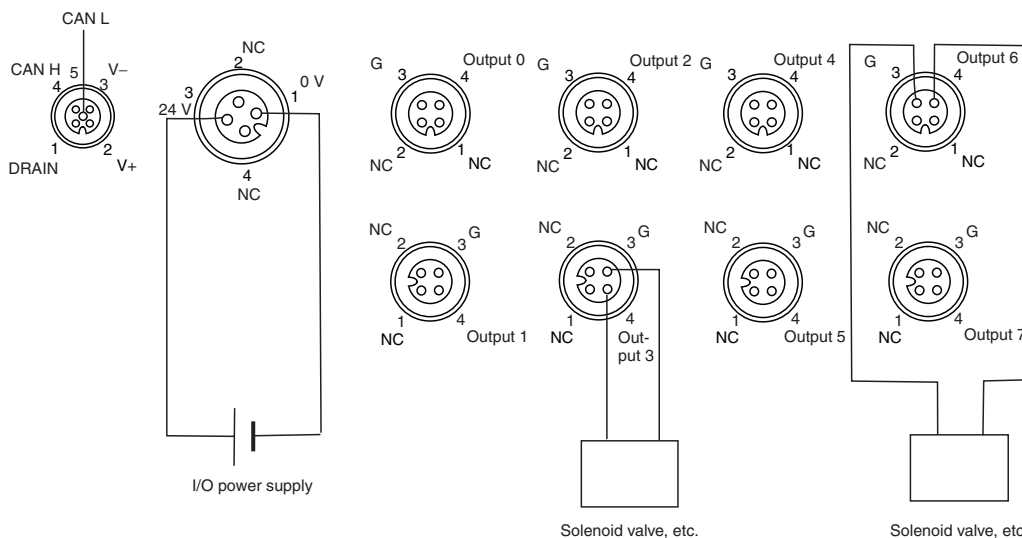

**Dimensions: DRT2-OD08CL and DRT2-OD08CL-1**

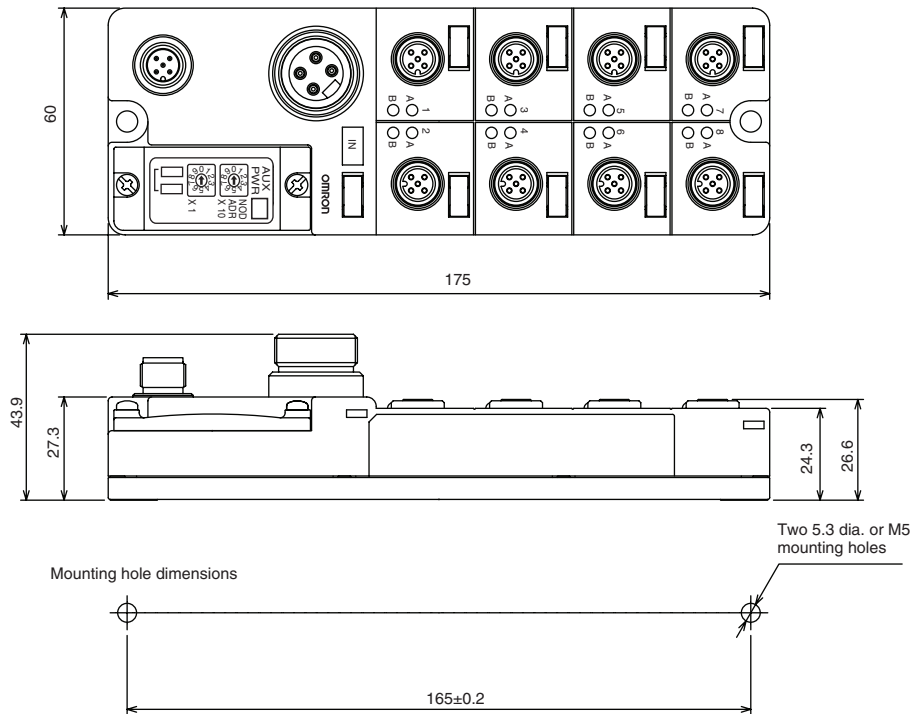

**6-5-7 Environment-resistive Terminals with 16 Transistor Outputs (IP67): DRT2-WD16CL (NPN) and DRT2-WD16CL-1 (PNP)**

**Output Specifications**

Item	Specifications	
Model	DRT2-WD16CL	DRT2-WD16CL-1
Internal I/O common	NPN	PNP
Output points	16 points	
Rated output current	0.5 A/point, 2.0 A/common	
I/O power supply voltage	20.4 to 26.4 V DC (24 V DC, -15 to +10%)	
Residual voltage	1.2 V max. (0.5 A DC, between each output terminal and G)	1.2 V max. (0.5 A DC, between each output terminal and V)
Leakage current	0.1 mA max.	
ON delay time	0.5 ms max.	
OFF delay time	1.5 ms max.	
Number of circuits	16 points with one common	

**Indicators**

**I/O Status Indicators**

The I/O status indicator displays and their meanings are shown in the following table. Refer to the section following on names of components and functions for details on the location of the I/O status indicators. In the indicator

name “1-A,” the “1” indicates the connector number, and the “A” indicates that it is an I/O status indicator.

Indicator	Color	Status	Meaning
1-A	Yellow	ON	Output 0 is ON.
1-B	Yellow	ON	Output 1 is ON.
2-A	Yellow	ON	Output 2 is ON.
2-B	Yellow	ON	Output 3 is ON.
3-A	Yellow	ON	Output 4 is ON.
3-B	Yellow	ON	Output 5 is ON.
4-A	Yellow	ON	Output 6 is ON.
4-B	Yellow	ON	Output 7 is ON.
5-A	Yellow	ON	Output 8 is ON.
5-B	Yellow	ON	Output 9 is ON.
6-A	Yellow	ON	Output 10 is ON.
6-B	Yellow	ON	Output 11 is ON.
7-A	Yellow	ON	Output 12 is ON.
7-B	Yellow	ON	Output 13 is ON.
8-A	Yellow	ON	Output 14 is ON.
8-B	Yellow	ON	Output 15 is ON.

**Note** Although the connectors are numbered from 1 to 8, the input bits are numbered from 0 to 7.

**I/O Power Supply Status Indicator**

Indicator	Color	Status	Meaning
AUX PWR	Green	ON	I/O power is being supplied.

**Component Names and Functions: DRT2-WD16CL and DRT2-WD16CL-1**

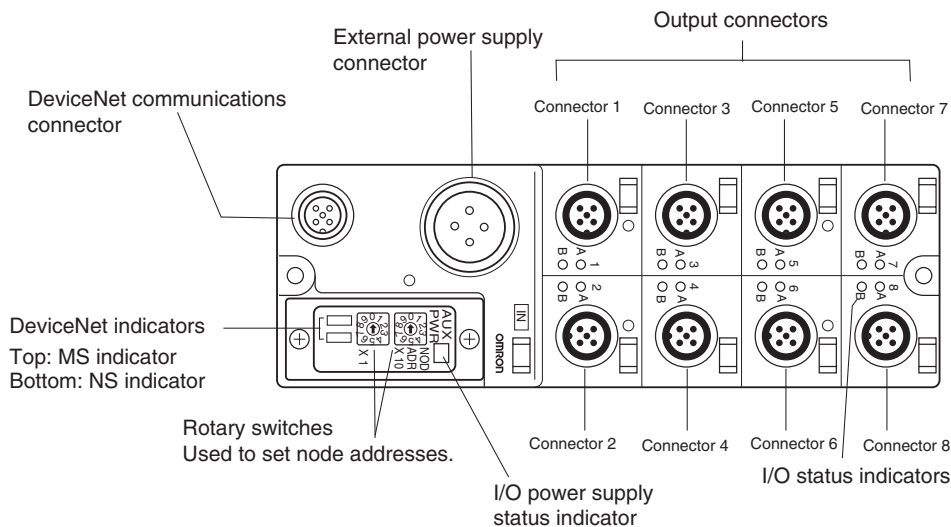



**Internal Circuits**

**DRT2-WD16CL (NPN)**

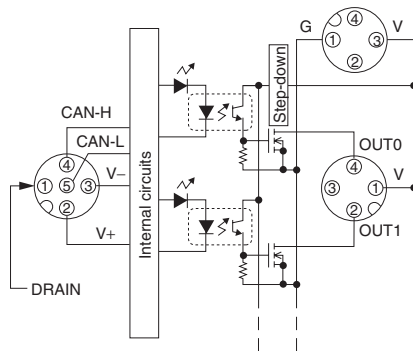

**DRT2-WD16CL-1 (PNP)**

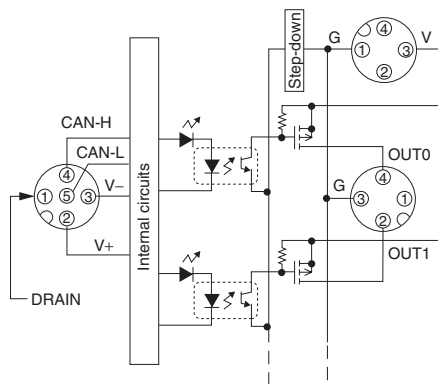

**Wiring**

**DRT2-WD16CL (NPN)**

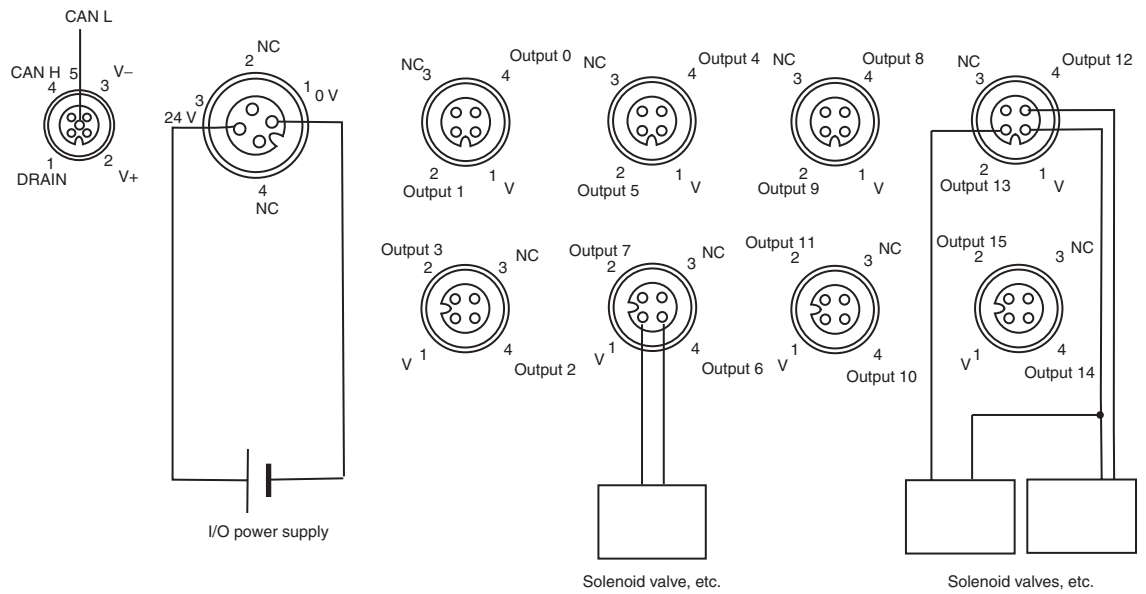

**DRT2-WD16CL-1 (PNP)**

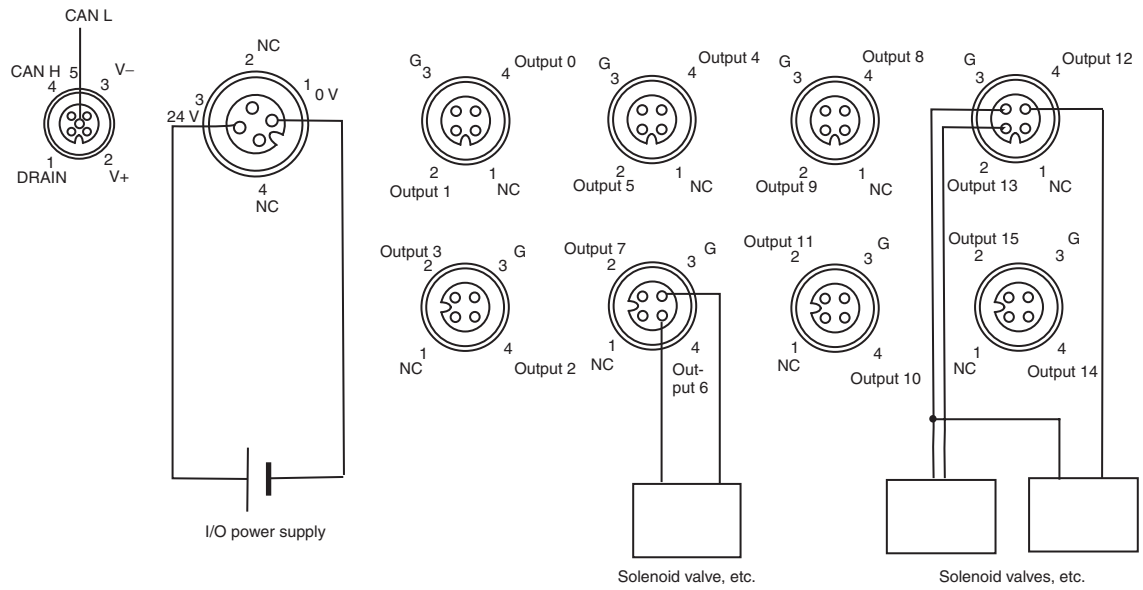

**Dimensions: DRT2-WD16CL and DRT2-WD16CL-1**

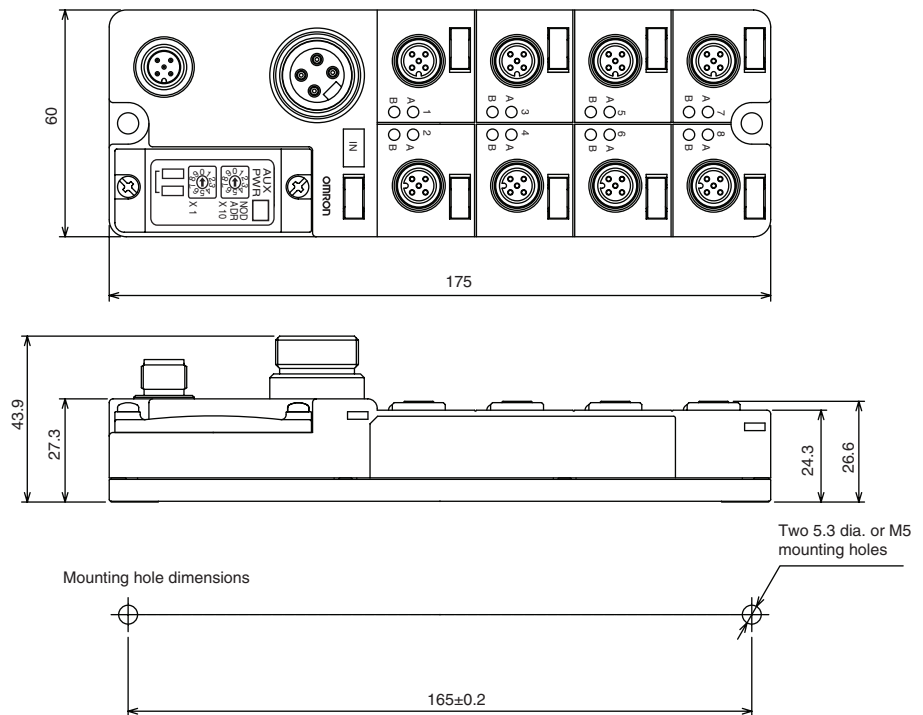

### 6-5-8 Environment-resistive Terminals with 8 Transistor Inputs and 8 Transistor Outputs (IP67): DRT2-MD16CL (NPN) and DRT2-MD16CL-1 (PNP)

#### Input Specifications

Item	Specifications	
Model	DRT2-MD16CL	DRT2-MD16CL-1
Internal I/O common	NPN	PNP
Input points	8 points	
ON voltage	15 V DC min. (between each input terminal and V)	15 V DC min. (between each input terminal and G)
OFF voltage	5 V DC max. (between each input terminal and V)	5 V DC max. (between each input terminal and G)
OFF current	1 mA max.	
Input current	6.0 mA max./point (for 24 V DC), 3.0 mA min./point (for 17 V DC)	
I/O power supply voltage	20.4 to 26.4 V DC (24 V DC, -15 to +10%)	
ON delay time	1.5 ms max.	
OFF delay time	1.5 ms max.	
Number of circuits	8 points with one common	

#### Output Specifications

Item	Specifications	
Model	DRT2-MD16CL	DRT2-MD16CL-1
Internal I/O common	NPN	PNP
Output points	8 points	
Rated output voltage	0.5 A/point, 4.0 A/common	
I/O power supply voltage	20.4 to 26.4 V DC (24 V DC, -15 to +10%)	
Residual voltage	1.2 V max. (0.5 A DC, between each output terminal and G)	1.2 V max. (0.5 A DC between each output terminal and V)
Leakage current	0.1 mA max.	
ON delay time	0.5 ms max.	
OFF delay time	1.5 ms max.	
Number of circuits	8 points with one common	

#### Indicators

##### **I/O Status Indicators**

The I/O status indicator displays and their meanings are shown in the following table. Refer to the section following on names of components and functions for details on the location of the I/O status indicators. In the indicator

name “1-A,” the “1” indicates the connector number, and the “A” indicates that it is an I/O status indicator.

Indicator	Color	Status	Meaning
1-A	Yellow	ON	Input 0 is ON.
1-B	Yellow	ON	Input 1 is ON.
2-A	Yellow	ON	Input 2 is ON.
2-B	Yellow	ON	Input 3 is ON.
3-A	Yellow	ON	Input 4 is ON.
3-B	Yellow	ON	Input 5 is ON.
4-A	Yellow	ON	Input 6 is ON.
4-B	Yellow	ON	Input 7 is ON.
5-A	Yellow	ON	Output 0 is ON.
5-B	Yellow	ON	Output 1 is ON.
6-A	Yellow	ON	Output 2 is ON.
6-B	Yellow	ON	Output 3 is ON.
7-A	Yellow	ON	Output 4 is ON.
7-B	Yellow	ON	Output 5 is ON.
8-A	Yellow	ON	Output 6 is ON.
8-B	Yellow	ON	Output 7 is ON.

**Note** Although the connectors are numbered from 1 to 8, the input bits are numbered from 0 to 7.

**I/O Power Supply Status Indicator**

Indicator	Color	Status	Meaning
IN AUX	Green	ON	IN power is being supplied.
OUT AUX	Green	ON	OUT power is being supplied.

**Component Names and Functions: DRT2-MD16CL and DRT2-MD16CL-1**

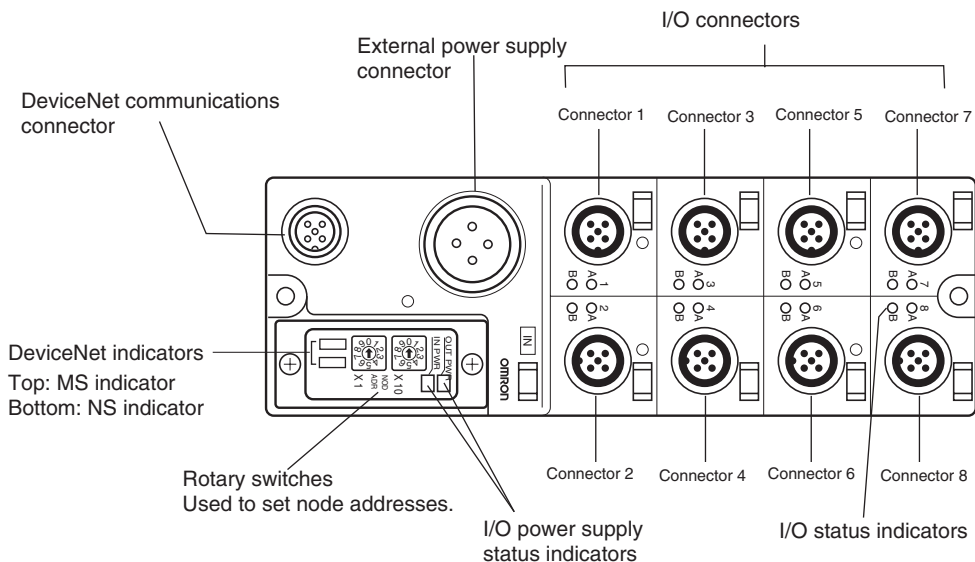

**Internal Circuits**

**DRT2-MD16CL (NPN)**

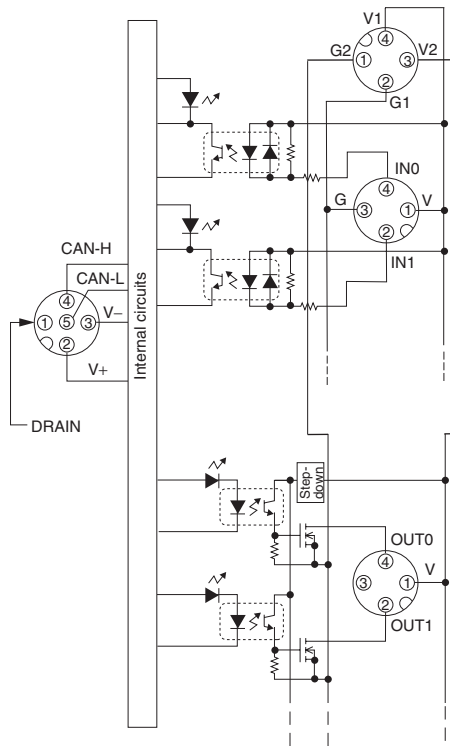

**DRT2-MD164CL-1 (PNP)**

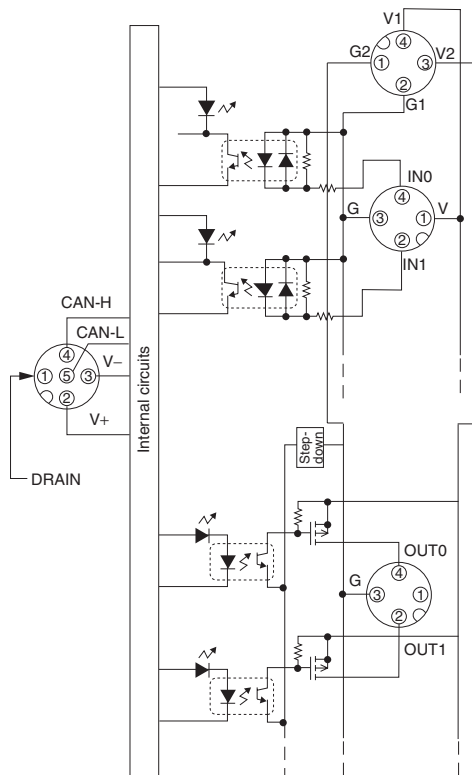

Wiring

DRT2-MD16CL (NPN)

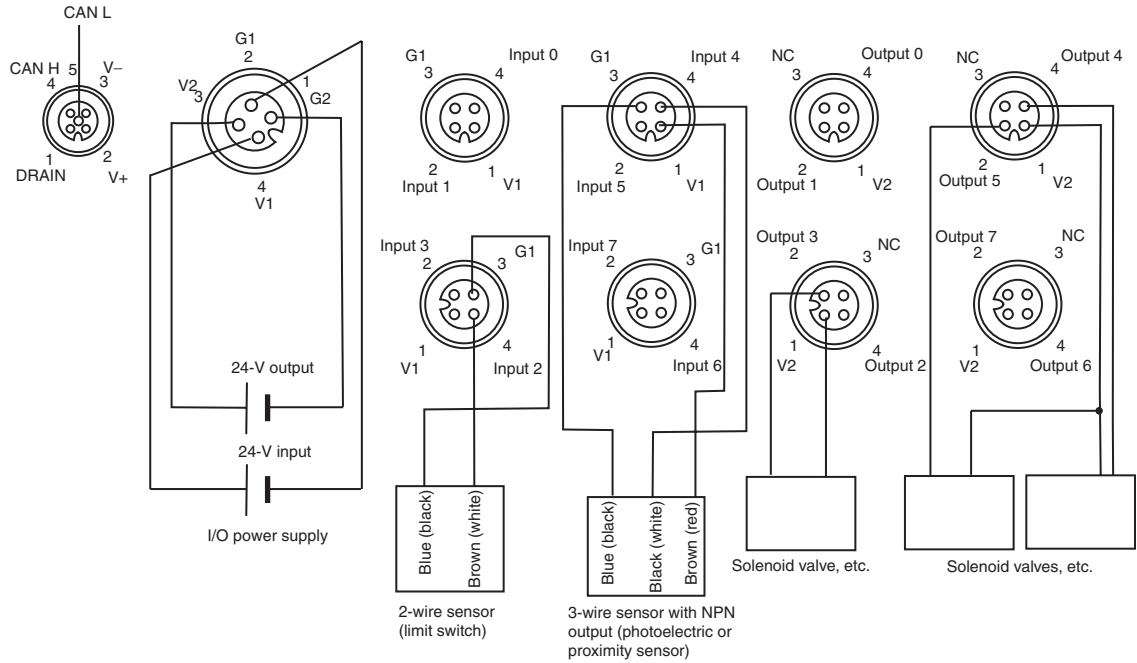

DRT2-MD16CL-1 (PNP)

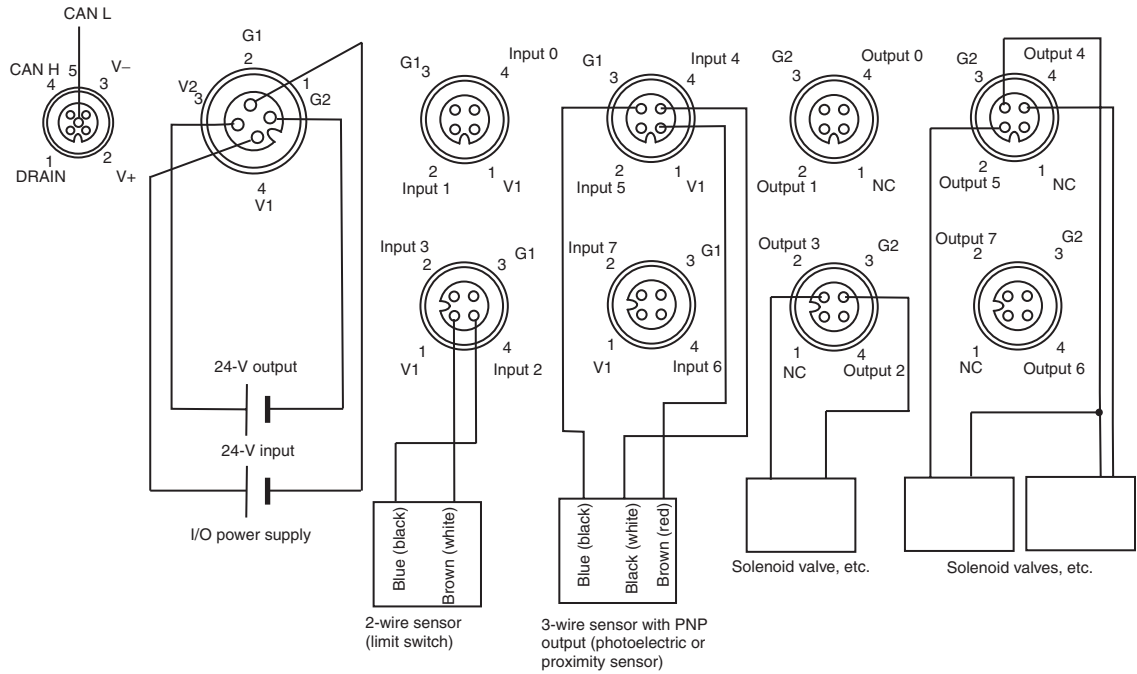

**Dimensions: DRT2-MD16CL and DRT2-MD16CL-1**

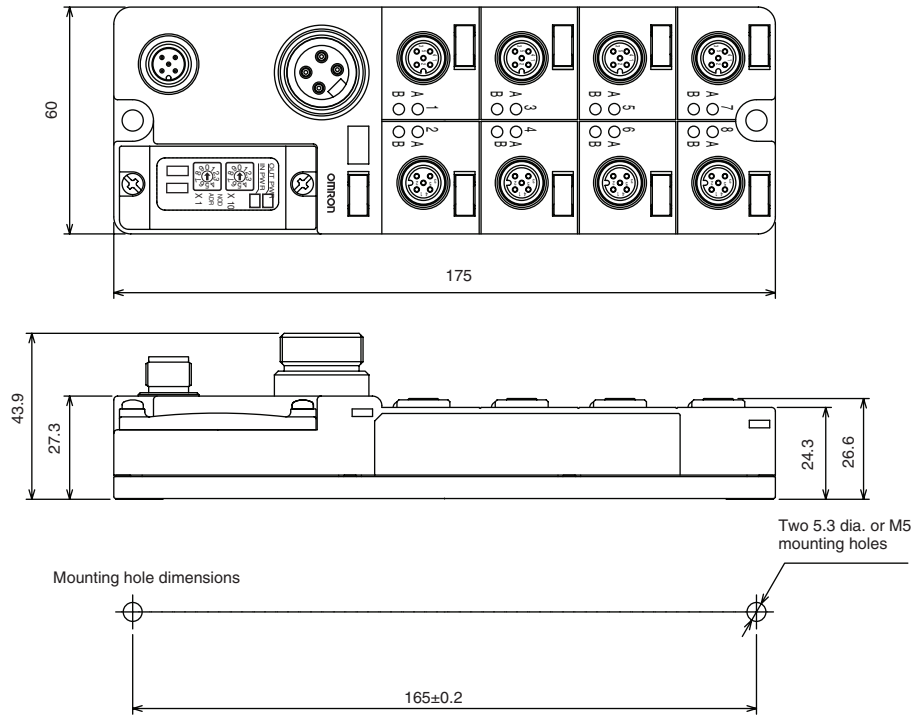

## 6-6 Mounting and Wiring Environment-resistive Slaves

### 6-6-1 Mounting in Control Panels

Use screws to mount the Environment-resistive Terminal in the Control Panel. Environment-resistive Terminals cannot be mounted on a DIN Track.

Drill the mounting holes in the control panel according to the dimensions shown in the dimensions diagrams and secure the Terminal with M5 screws.

The appropriate tightening torque is 1.47 to 1.96 N-m.

#### Mounting Direction

The terminal can be mounted in any of the following six directions.

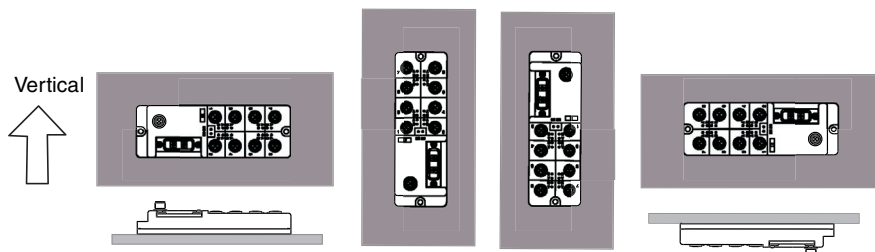

### 6-6-2 Wiring the Internal Power Supply, I/O Power Supply, and I/O Lines

#### Wiring the Internal Power Supply and I/O Power Supply

DRT2-ID08C(-1) and  
DRT2-HD16C(-1)

The internal power supply and I/O power supply share the communications power supply so an external power supply is not required.

DRT2-ID04CL(-1),  
 DRT2-OD04CL(-1),  
 DRT2-OD08C(-1),  
 DRT2-ID08CL(-1),  
 DRT2-OD08CL(-1),  
 DRT2-HD16CL(-1),  
 DRT2-WD16CL(-1)  
 and DRT2-MD16CL(-1)

The internal power supply shares the communications power supply, but the I/O power supply must be supplied from external power supply connectors. The DRT1-series Environment-resistive Terminals used I/O power supply cables with connectors (XS2W-D42□-□8□-□) that are different to the connectors used with the DRT2-series Terminals. Always use the compatible power supply connectors listed in the following table.

Compatible Connectors

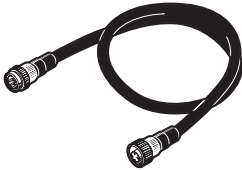
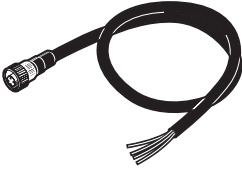
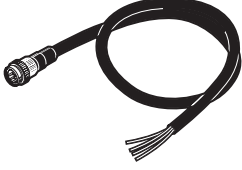
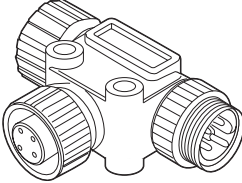
Connector	Mode	
Cable with connectors on both ends (socket and plug)	XS4W-D421-1□□-A	
Cable with connector on one end (female socket)	XS4F-D421-1□□-A	
Cable with connector on one end (male plug)	XS4H-D421-1□□-A	
T-joint	XS4R-D424-5	

Example System Assembly

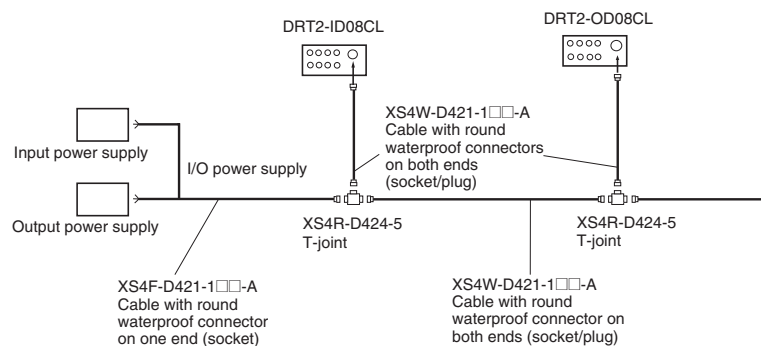

- Note**
1. Tighten the connector by hand to a torque of 0.39 to 0.49 N·m. If the connector is not tightened sufficiently, it will not provide the expected degree of protection and may become loose due to vibration. Do not use pliers or other tools to tighten the connectors, because these tools may damage the connectors.
  2. The OMRON S8□□ Power Supply Unit is recommended for the I/O power supply. The load short-circuit detection function uses the transistor's ther-



mal shutdown, so when a Power Supply Unit with a low-capacity rating or instantaneous shutoff overcurrent protection is used, the load short-circuit may not be detected. Always use a Power Supply Unit with a rating of 50 W or higher if it uses dropping overcurrent protection characteristic. Always use a Power Supply Unit with a rating of 150 W or higher if it uses intermittent overcurrent protection. The current limiter will protect the transistor even if short-circuit detection is disabled.

**Wiring I/O**

Connect the I/O wiring to the Environment-resistive Terminal with the XS2-series Round Waterproof Connectors listed in the following table.

**Compatible Connectors**

Connector	Model
Cable with connector on one end (male plug)	XS2H-D421-□80-A
Cable with connectors on both ends (socket and plug)	XS2W-D42□-□81-A
Connector plug assembly (male) (Crimp-connector or solder type)	XS2G-D4□□

Sensors that are pre-wired with a connector can be connected directly. Refer to the catalog or manual for details on the device's pin arrangements before connecting any device.

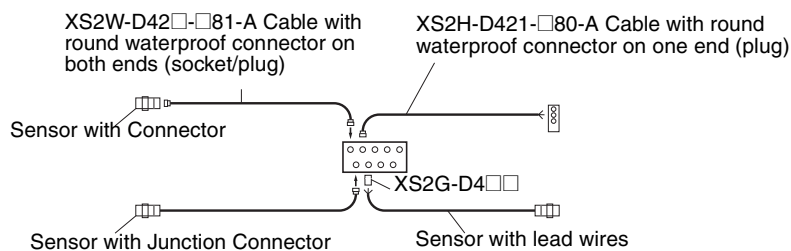

**Note** Refer to the OMRON Sensors Catalog (X42) for details on Sensor Connections and Round Waterproof Connectors (Sensor I/O Connectors).

Use one of the following OMRON Y-joints when connecting a DRT2-HD16C(-1), DRT2-HD16CL(-1), or DRT2-MD16CL(-1) Environment-resistive Terminal with 16 inputs to sensors or limit switches, except when the sensor has diagnostic output.

Connector	Model
Y-joint with plug/socket (connector on both ends)	XS2R-D426-□11-F
Y-joint with plug/socket (without cable)	XS2R-D426-1

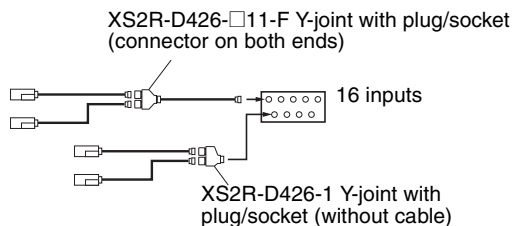

**Note** The XS2G Connector Plug for Custom Cable Assembly (L-shaped type) and XS2W-series L-shaped plug type cannot be connected to a Y-joint Connector, because these connectors will cause interference with any Connectors located beside them.

**XS2R-D426-□11-F Y-joint with Plug/Socket (Connector on Both Ends)**

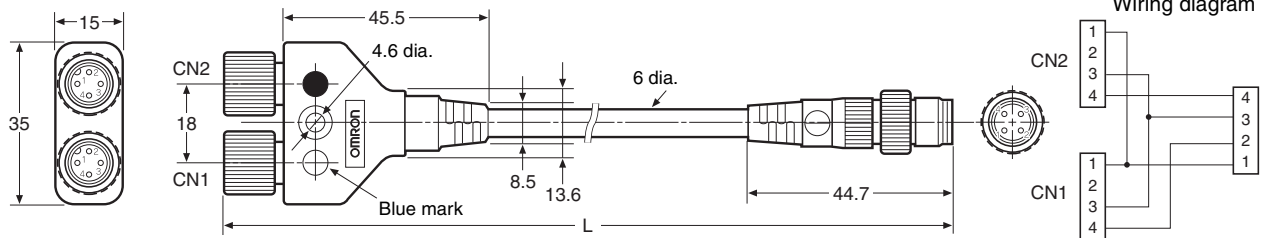

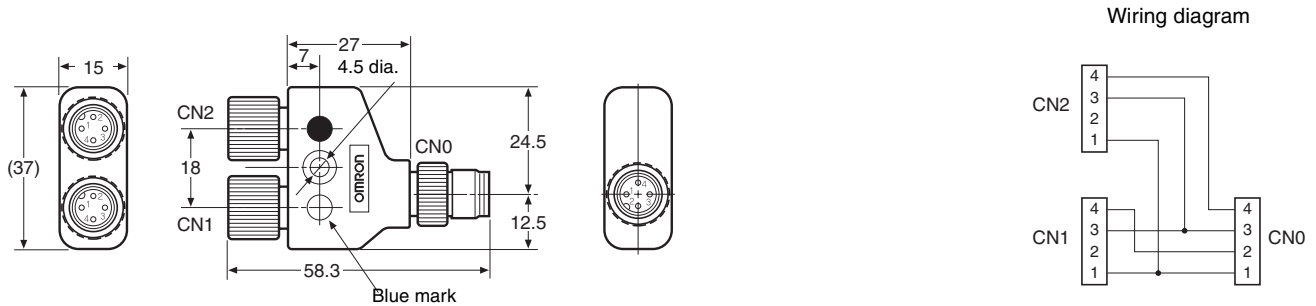

**Note** Refer to the *Sensor I/O Connector Group Catalog* (Cat. No. X073) for details.

**XS2R-D426-1 Y-joint with Plug/Socket (without Cable)**

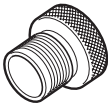
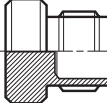

**Note** Tighten the connector by hand to a torque of 0.39 to 0.49 N·m. If the connector is not tightened sufficiently, it will not provide the expected degree of protection and may become loose due to vibration. Do not use pliers or other tools to tighten the connectors, because these tools may damage the connectors.

Always cap unused connectors with an XS2Z-12 Waterproof Cover or XS2Z-15 Dust Cover shown in the following diagram.

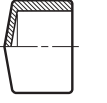
XS2Z-12 Waterproof Cover		XS2Z-15 Dust Cover	
			
The connector will meet IP67 standards if a Waterproof Cover is attached. Always tighten the connector by hand to a torque of 0.39 to 0.49 N·m.		Press the Dust Cover onto the connector firmly. The Dust Cover will protect the connector from dust, but does not meet IP67 standards.	

**Maintaining Enclosure Ratings**

- Note**
- The IP67 enclosure rating will not be met if the surfaces where the contact block and cover meet are subjected to excessive force. Protect the contact block and cover from excessive force.  
The IP67 standard is lower than waterproof standards. Do not submerge the system components.  
The body of the components is plastic resin. Do not place objects on the components or allow the components to be stepped on.
  - There are two kinds of wiring for OMRON Two-wire Proximity Sensors (pre-wired with connector). One switch has IEC pin arrangement (M1GJ type) and the other has OMRON pin arrangement (M1J type). Refer to the

following table to determine the appropriate Environment-resistive Terminal to use with each kind of switch.

<b>Two-wire Proximity Sensor (pre-wired with connector)</b>	<b>Compatible Terminal</b>
IEC pin arrangement (M1GJ type)	DRT2-ID08C-1 DRT2-HD16C-1
OMRON pin arrangement (M1J type)	DRT2-ID08C DRT2-HD16C

# SECTION 7

## Analog Slaves

This section provides the specifications, terminal arrangements, mounting procedures, and connection methods of Analog I/O Terminals. Information is included on types of I/O data that can be allocated, allocation methods and procedures, and math operation processing. Setting methods using the Configurator are also described.

7-1	Overview of Analog Slaves . . . . .	292
7-1-1	DRT2 Analog Slaves . . . . .	292
7-1-2	Comparison of DRT1 and DRT2 Functions . . . . .	292
7-1-3	List of Data Processing Functions . . . . .	295
7-1-4	Data Processing Flowcharts (Analog/Temperature Input Terminals)	297
7-1-5	Selecting Data (Analog/Temperature Input Terminals) . . . . .	298
7-1-6	I/O Data Allocated in the Master . . . . .	301
7-1-7	Allocating I/O Data in the Master . . . . .	303
7-1-8	Procedure for Allocating I/O in the Master . . . . .	304
7-1-9	Application Procedure Flowchart . . . . .	305
7-2	Common Procedures . . . . .	308
7-2-1	Connecting Communications Cables . . . . .	308
7-2-2	Node Address and Baud Rate Settings . . . . .	308
7-2-3	Mounting in Control Panels . . . . .	309
7-2-4	Wiring the I/O Lines . . . . .	310
7-3	Maintenance Information Window . . . . .	310
7-3-1	Checking Maintenance Information . . . . .	310
7-4	Analog Input Terminals . . . . .	315
7-4-1	DRT2-AD04 and DRT2-AD04H Analog Input Terminals . . . . .	315
7-4-2	I/O Data Allocation Methods . . . . .	325
7-4-3	Functions and Settings . . . . .	335
7-4-4	Calculating the Conversion Cycle (DRT2-AD04 Only) . . . . .	358
7-5	Analog Output Terminals . . . . .	359
7-5-1	DRT2-DA02 Analog Output Terminal . . . . .	359
7-5-2	I/O Data Types and Allocation Methods . . . . .	364
7-5-3	Functions and Setting Methods . . . . .	368
7-6	Temperature Input Terminals . . . . .	377
7-6-1	DRT2-TS04T and DRT2-TS04P Temperature Input Terminals . . . . .	377
7-6-2	Temperature Input Terminal Display Modes . . . . .	385
7-6-3	I/O Data Selection and Allocation . . . . .	393
7-6-4	Functions and Settings . . . . .	406

## 7-1 Overview of Analog Slaves

This section provides an overview of Analog Slaves, including details on functions and setting methods for each Slave.

### 7-1-1 DRT2 Analog Slaves

Compared with the previous DRT1 Analog Slaves, DRT2 Analog Slaves combine the maintenance functions (network power voltage monitor and Unit conduction time monitor) of DRT2-series Slaves with various functions of Analog Slaves (such as scaling and peak/bottom hold). Analog Input Terminals are also able to internally perform math on analog input values, which previously required ladder programming in the Master CPU Unit. Analog data or temperature data can be selected from the six values obtained from math operations and allocated in the Master in combination with Generic Status Flags or other status information. (Status information alone can also be allocated.) The Configurator or explicit messages can be used to allocate data in the Master, and to set Analog Slave functions and perform monitoring.

### 7-1-2 Comparison of DRT1 and DRT2 Functions

#### Analog Input Terminals

Slave	DRT1 Series		DRT2 Series	
Model	DRT1-AD04	DRT1-AD04H	DRT2-AD04	DRT2-AD04H
Analog points	4 inputs			
Input range (signals)	0 to 5 V, 1 to 5 V, 0 to 10 V, -10 to 10 V, 0 to 20 mA, 4 to 20 mA	0 to 5 V, 1 to 5 V, 0 to 10 V, 0 to 20 mA, 4 to 20 mA (-10 to 10 V not supported)	0 to 5 V, 1 to 5 V, 0 to 10 V, -10 to 10 V, 0 to 20 mA, 4 to 20 mA	0 to 5 V, 1 to 5 V, 0 to 10 V, 0 to 20 mA, 4 to 20 mA (-10 to 10 V not supported)
AD conversion cycle	2 ms/point (8 ms/4 points or 4 ms/2 points)	250 ms/ 4 points	By setting the number of conversion points (1 to 4 points), the conversion cycle can be shortened (e.g., 4 points: 4 ms max.)  <b>Note</b> The conversion cycle will be slightly different when the math operations are used.	250 ms/ 4 points
AD conversion data	0 to 5 V, 1 to 5 V, 0 to 10 V, 0 to 20 mA, 4 to 20 mA: 0000 to 1770 hex -10 to 10 V: 8BB8 to 0BB8 hex <b>Note</b> Signed binary	0 to 5 V, 1 to 5 V, 0 to 10 V, 0 to 20 mA, 4 to 20 mA: 0000 to 7530 hex  <b>Note</b> Two's complement	0 to 5 V, 1 to 5 V, 0 to 10 V, 0 to 20 mA, 4 to 20 mA: 0000 to 1770 hex -10 to 10 V: F448 to 0BB8 hex  <b>Note</b> Two's complement	0 to 5 V, 1 to 5 V, 0 to 10 V, 0 to 20 mA, 4 to 20 mA: 0000 to 7530 hex  <b>Note</b> Two's complement
Resolution	1/6,000 (full scale)	1/30,000 (full scale)	1/6,000 (full scale)	1/30,000 (full scale)
Unit power supply	Supplied by local power supply terminal.		Supplied by communications power supply.	
Communications power supply current consumption	30 mA max.		90 mA max.	70 mA max.
Overall accuracy	25°C	Voltage input: ±0.3% FS; Current input: ±0.4% FS		
	-10 to 55°C	0 to 55°C: Voltage input: ±0.6% FS; Current input: ±0.8% FS	-10 to 55°C: Voltage input: ±0.6% FS; Current input: ±0.8% FS	

Slave	DRT1 Series		DRT2 Series	
Model	DRT1-AD04	DRT1-AD04H	DRT2-AD04	DRT2-AD04H
Data allocated in Master	Only analog input values for 4 inputs		Default: Analog input values for 4 points The Configurator can be used to allocate peak, bottom, top, and valley values, rate of change, comparator results, Generic Status Flags, etc.	
Input switching (Sets number of AD conversion points)	Supported. (Set using DIP switch: Select either 2 or 4 points)	Not supported.	Supported (Set using Configurator: Select from 1 to 4 points)	Not supported.
Input range switching	Set using rotary switches: Inputs 0 and 2 share one setting, and Inputs 1 and 3 share another setting.		<ul style="list-style-type: none"> <li>Using DIP switch: Inputs 0 and 1 share setting, Inputs 2 and 3 share setting.</li> <li>Using Configurator: Inputs 0 to 3 set separately.</li> </ul>	
Node address setting	Set using DIP switch.		Set using the rotary switches or the Configurator.	
Baud rate setting	Set using DIP switch.		Automatically detected: Uses baud rate set for Master Unit.	
Moving average	Supported. (Set using DIP switch.)	Not supported.	Supported. (Set using Configurator.)	
Off-wire detection	Supported.			
Scaling, offset compensation, peak/bottom hold, top/valley hold, rate of change operations, comparator, user adjustment (maintenance function), cumulative counter (maintenance function), last maintenance date (maintenance function)	Not supported.		Supported. (Set using Configurator.)	

### Analog Output Terminals

Slave	DRT1 Series		DRT2 Series	
Model	DRT1-DA02		DRT2-DA02	
Analog points	2 outputs			
Output signal range	1 to 5 V, 0 to 10 V, -10 to 10 V, 0 to 20 mA, 4 to 20 mA (0 to 5 V not supported)		0 to 5 V, 1 to 5 V, 0 to 10 V, -10 to 10 V, 0 to 20 mA, 4 to 20 mA	
Conversion time	4 ms/2 points		2 ms/2 points	
AD conversion data	0 to 5 V, 1 to 5 V, 0 to 10 V, 0 to 20 mA, 4 to 20 mA: 0000 to 1770 hex -10 to 10 V: 8BB8 to 0BB8 hex <b>Note</b> Signed binary		0 to 5 V, 1 to 5 V, 0 to 10 V, 0 to 20 mA, 4 to 20 mA: 0000 to 1770 hex -10 to 10 V: F448 to 0BB8 hex <b>Note</b> Two's complement	
Resolution	1/6,000 (full scale)			
Unit power supply	Supplied by local power supply terminal.		Supplied by communications power supply.	
Communications power supply current consumption	30 mA max.		120 mA max.	
Overall accuracy	25°C	Voltage output: ±0.3% FS; Current output: ±0.4% FS		
	-10 to 55°C	0 to 55°C: Voltage output: ±0.6% FS; Current output: ±0.8% FS		
Data allocated in Master	Only Analog output values for 2 outputs		Default: Analog output values for 2 points The Configurator can be used to allocate Generic Status Flags.	

Slave	DRT1 Series	DRT2 Series
<b>Model</b>	<b>DRT1-DA02</b>	<b>DRT2-DA02</b>
Input range switching	Set using the rotary switches.	Set using the DIP switch or the Configurator.
Node address setting	Set using the DIP switch.	Set using the rotary switches or the Configurator.
Baud rate setting	Set using the DIP switch.	Automatically detected: Uses the baud rate set for the Master Unit.
Communications error output	Set using the DIP switch.	Set using the Configurator.
Scaling, user adjustment (maintenance function), cumulative counter (maintenance function), last maintenance date (maintenance function)	Not supported.	Supported. (Set using the Configurator.)

**Temperature Input Terminals**

Slave	DRT1 Series		DRT2 Series	
<b>Model</b>	<b>DRT1-TS04T</b>	<b>DRT1-TS04P</b>	<b>DRT2-TS04T</b>	<b>DRT2-TS04P</b>
Input type	Thermocouple	Platinum resistance thermometer	Thermocouple	Platinum resistance thermometer
Dimensions	150 × 40 × 50 (W × H × D)		115 × 49.7 × 50 (W × H × D)	
Maintenance method	Replacement of each Unit		Just the Terminal Block can be removed.	
Input type setting method	Set with a Rotary Switch.		Set with a DIP switch (hardware) setting or Configurator (software) setting.	
Input type setting	All 4 inputs are set together.		Inputs can be set individually. (All inputs are set to the same input type if the DIP switch (hardware) setting is used. In addition, the following settings cannot be set individually: Off-wire (disconnection) display setting, Number of display digits setting, and °C/°F setting.)	
Input type (sensor type)	R, S, K1, K2, J1, J2, T, B, L1, L2, E, U, N, W, PL2	PT, JPT	R, S, K1, K2, J1, J2, T, B, L1, L2, E, U, N, W, PL2	PT, JPT, PT2, JPT2
Input accuracy	±0.5% of indication value or ±2°C, whichever is larger) ±1 digit max.	±0.5% of indication value or ±1°C, whichever is larger) ±1 digit max.	±0.3% of indication value or ±1°C, whichever is larger) ±1 digit max. (See note.)	–200 to 850°C input range: ±0.3% of indication value or ±0.8°C, whichever is larger) ±1 digit max. –200 to 200°C input range: ±0.3% of indication value or ±0.5°C, whichever is larger) ±1 digit max.
Conversion cycle	250 ms/ 4 points			
1/100 display mode	The temperature data is multiplied by 100 and sent to the Master as 6-digit hexadecimal data. In this case, the hexadecimal data is divided into two parts and the parts are sent alternately each 125 ms. (The data is sent in 1-word units).		The temperature data is multiplied by 100 and sent to the Master as 8-digit hexadecimal data. (The data is sent in 2-word units).	
DRT1-compatible 1/100 display mode	---		The temperature data is multiplied by 100 and sent to the Master as 6-digit hexadecimal data. In this case, the hexadecimal data is divided into two parts and the parts are sent alternately each 125 ms. (The data is sent in 1-word units).	

Slave		DRT1 Series	DRT2 Series
Unit power supply		Supplied by local power supply terminal.	Supplied by communications power supply.
Communications power supply current consumption		30 mA max.	70 mA max.
Connections		Poll, Bitstrobe	Poll, Bitstrobe, COS/cyclic
Data allocated in Master		Just temperature data for 4 inputs	Default: Temperature data for 4 inputs The following data items can be allocated by making additional Configurator settings: Peak value, Bottom value, Top value, Valley value, Rate-of-change value, Comparator result; Generic Status Flags, etc.
Node address setting		Set using the DIP switch.	Set using the rotary switches or the Configurator.
Baud rate setting		Set using the DIP switch.	Automatically detected: Uses the baud rate set for the Master Unit.
Moving average		Not supported.	Supported. (Set using Configurator.)
Off-wire (disconnection) detection		Supported.	
Scaling, offset compensation, peak/bottom hold, top/valley hold, rate of change operations, comparator		Not supported.	Supported. (Set using Configurator.)
Maintenance functions	User adjustment	Not supported.	Supported. (Set using Configurator.)
	Cumulative counter		
	Last maintenance date		
	Input temperature variation detection function		
	Temperature integration function		
	Top/Valley count function		
	Temperature range timing function		

**Note** The input accuracy depends on the mounting method. For details, refer to the *Performance Specifications* in 7-6-1 *DRT2-TS04T and DRT2-TS04P Temperature Input Terminals*.

### 7-1-3 List of Data Processing Functions

The following tables list the data processing functions that can be used with Analog Slaves. Refer to 7-4-3 *Functions and Settings* for details on functions and setting methods.

#### DRT2-AD04/DRT2-AD04H Analog Input Terminals

Function	Details	Default
Moving average	Calculates the average of the past eight analog input values, and produces a stable input value even when the input value is unsteady.	Moving average disabled.
Setting the number of AD conversion points (DRT2-AD04 only)	By reducing the number of input conversion points, the conversion cycle speed can be increased. For details, refer to 7-4-4 <i>Calculating the Conversion Cycle (DRT2-AD04 Only)</i> .	4-point conversion



Function	Details	Default
Scaling	Performs scaling. Scaling allows conversion of values between 0 and 6,000 (0 to 30,000 in the DRT2-AD04H) into values using the industry unit required by the user. It reduces the number of operations requiring ladder programming in the Master CPU Unit. Scaling also supports an offset function for compensating for mounting errors in sensors and other devices.	0 to 6,000 (DRT2-AD04) 0 to 28,000 (DRT2-AD04H)
Peak/bottom hold	Holds the maximum and minimum analog input values.	Disabled
Top/valley hold	Holds the top and valley values for analog input values.	Disabled
Rate of change	Calculates the rate of change for analog input values.	Disabled
Comparator	Compares the analog input value or an analog value after math processing (value for peak, bottom, top, valley, rate of change) with the four set values HH, H, L, and LL, and indicates the result with the Analog Status Flags.	Disabled
Off-wire detection	Detects disconnections of analog inputs. (Valid only for the input ranges 4 to 20 mA and 1 to 5 V)	Enabled
User adjustment	Adjusts the input when an offset occurs in the input voltage or current.	Disabled
Cumulative counter	Calculates an approximation to the integral of analog input values over time.	Disabled
Last maintenance date	Records the date of the last maintenance in the Unit.	2002/1/1 (DRT2-AD04) 2004/1/1 (DRT2-AD04H)

### DRT2-DA02 Analog Output Terminals

Function	Details	Default
Scaling	Performs scaling. Scaling allows conversion of values between 0 and 6,000 into values using the industry unit required by the user. It reduces the number of operations required in ladder programming in the Master.	Disabled (0 to 6,000)
User adjustment	Adjusts the output when an offset occurs in the output voltage or current.	Disabled
Cumulative counter (maintenance function)	Calculates an approximation to the integral of analog output values over time.	Disabled
Error output value setting	Sets the value output when a communications error occurs for each output.	Low limit
Last maintenance date	Records the date of the last maintenance in the Unit.	2002/1/1

### DRT2-TS04T/DRT2-TS04P Temperature Input Terminals

Function	Details	Default
Moving average	Calculates the average of the past eight temperature input values, and produces a stable input value even when the input value is unsteady.	Moving average disabled.
Scaling	Performs scaling. Scaling allows input values to be converted using default upper and lower limits that can be set independently in each Unit. The scaling function reduces the number of operations requiring ladder programming in the Master CPU Unit. Scaling also provides an offset function to compensate for mounting errors in sensors and other devices.	Disabled 0 to 28,000
Peak/bottom hold	Holds the maximum and minimum temperature input values.	Disabled
Top/valley hold	Holds the top and valley temperature input values.	Disabled
Rate of change	Calculates the rate of change of temperature input values.	Disabled

Function		Details	Default
Comparator		Compares the temperature input value or an analog value after math processing (value for peak, bottom, top, valley, rate of change) with the four set values HH, H, L, and LL, and indicates the result with the Analog Status Flags.	Disabled
Off-wire detection		Detects disconnections of analog inputs.	Enabled
User adjustment		An offset caused by hardware inaccuracy (or other factor) can be corrected with an arbitrary user-set input value.	Disabled
Last maintenance date		Records the date of the last maintenance in the Unit.	2004/1/1
Input temperature variation detection function		Makes a relative comparison of two inputs and detects a temperature difference between two inputs.	Disabled
Replacement monitoring functions	Temperature integration function	Compiles the total heat exposure of a device or sensor by multiplying the temperature and measurement time.	Disabled
	Top/Valley count function	Counts the number of heating cycles handled by a device or application that has fixed cycles of temperature changes.	Disabled
	Temperature range timing function	Measures how long the system is at a user-set temperature or within a user-set temperature range.	Disabled

### 7-1-4 Data Processing Flowcharts (Analog/Temperature Input Terminals)

#### Analog Input Value or Temperature Input Value

The following math operations can be performed on the external analog input value or temperature input value. The values obtained after processing (analog input values or temperature input values) can be allocated as I/O in the Master.

- Scaling to desired industry unit
- Moving average processing (not supported by the DRT2-AD04H)

#### Other Operation Results

After moving average and scaling processing, the analog input value or temperature input value can be processed using the following operations. The values after processing are called peak value, bottom value, top value, valley value, rate of change, and cumulated value.

- Peak/hold operation
- Top/valley operation
- Rate of change operation
- Cumulative operation (maintenance function)

Analog processing is performed according to the following flowchart.

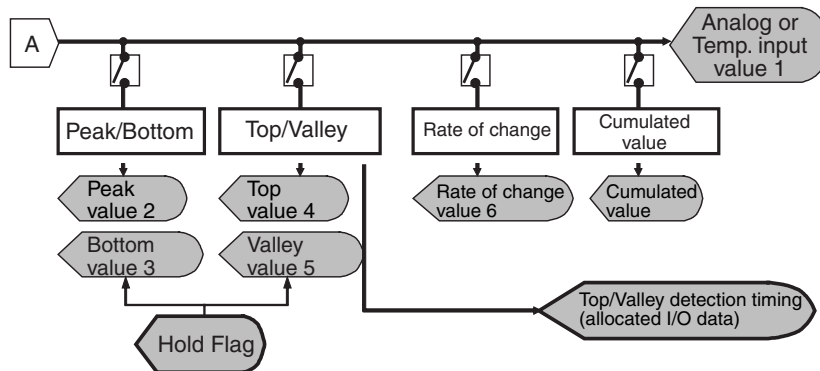
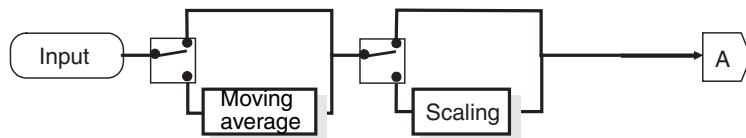

Data Flow

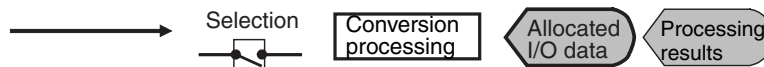

### 7-1-5 Selecting Data (Analog/Temperature Input Terminals)

After performing math operations, select up to two of the six resulting values to allocate in the Master, from the analog/temperature input value, peak value, bottom value, top value, valley value, and rate of change. The selected data is referred to as “analog data” or “temperature data,” and can be allocated in the Master individually or in combination with Status Flags. The data is selected using the Configurator or explicit messages. For Analog Data 1 or Temperature Data 1, comparison operations with four alarm set values can be performed (comparator function).

**Flow of Data in Analog Input Terminals**

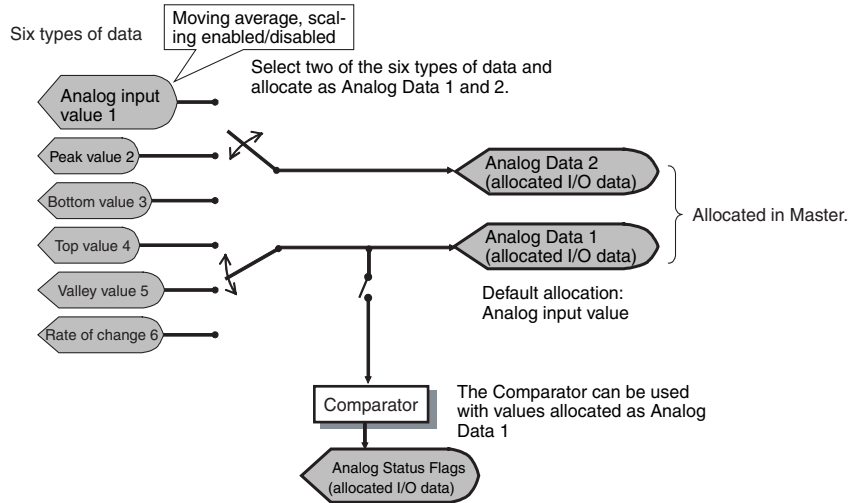

For Inputs 0 to 3, Analog Data 1 and 2 can be separately selected, as shown in the following diagram.

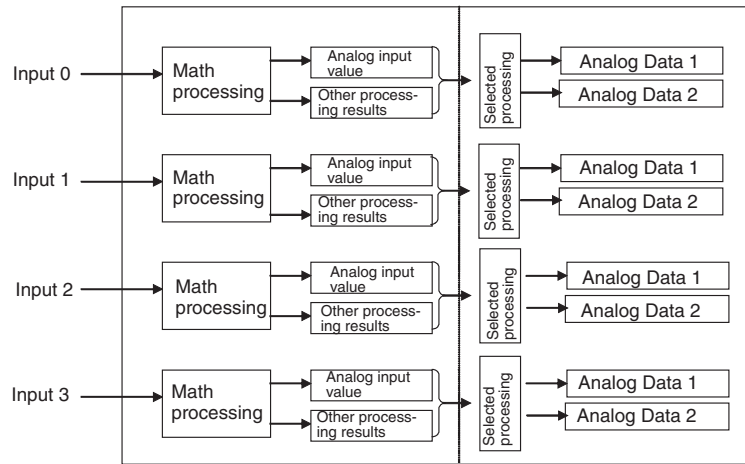

**Flow of Data in Temperature Input Terminals**

In a Temperature Input Terminal, it is possible to select from six types of data and switch the display mode. The display mode can be “normal display mode”

or “1/100 display mode” and the data can be allocated as “Temperature Data 1” or “Temperature Data 2.”

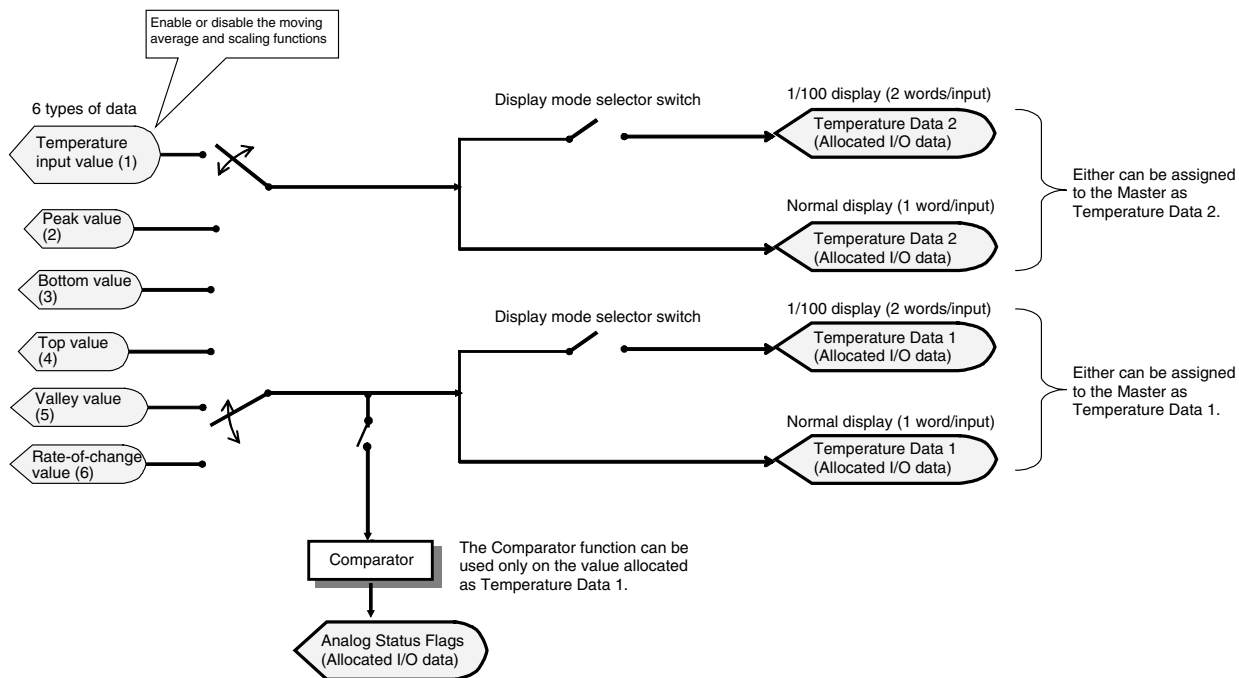

**Note** The Temperature Data 1 and Temperature Data 2 settings must be set to “normal display” when using the DRT1-compatible 1/100 display mode. Refer to 7-6-2 Temperature Input Terminal Display Modes for details on the DRT1-compatible 1/100 display mode.

Temperature Data 1 and Temperature Data can be selected separately with inputs 0 to 3, as shown in the following diagram.

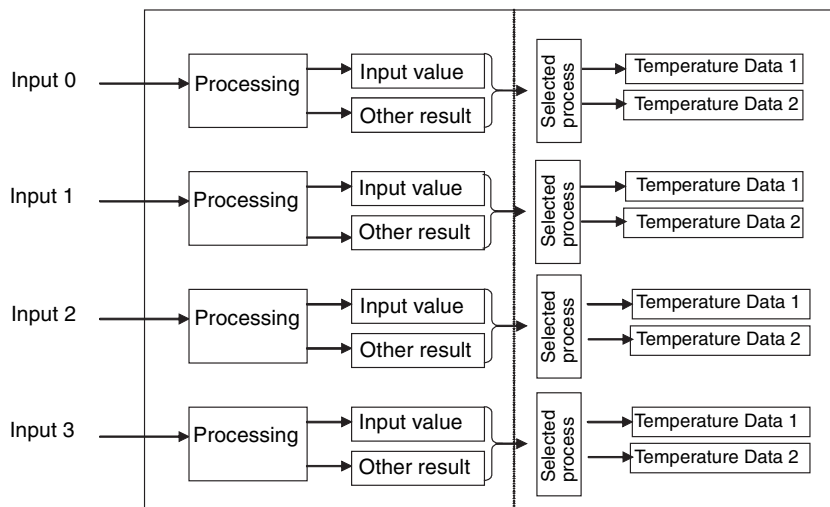

### 7-1-6 I/O Data Allocated in the Master

#### Analog and Temperature Input Terminals

Analog Input Terminals and Temperature Input Terminals support the following five types of input data (three of which are Status Flags), and one type of output data. The required data can be allocated in the Master either individually or in combination with other data.

#### Individual Input Data

I/O data	Details	Assembly Instance No.
Analog Data 1 (8 input bytes) Temperature Data 1 (Normal display: 8 input bytes 1/100 display: 16 input bytes)	<ul style="list-style-type: none"> <li>Used to monitor analog data or temperature data.</li> <li>Select one type of data from analog/temperature input value, peak value, bottom value, top value, valley value, or rate of change. (Default allocation: Analog or Temperature input value)</li> </ul> <p><b>Note</b> The comparator can be used with Analog Data 1 or Temperature Data 1.</p>	104 108 (for 1/100 display of Temperature Data, see note)
Analog Data 2 (8 input bytes) Temperature Data 2 (Normal display: 8 input bytes 1/100 display: 16 input bytes)	<ul style="list-style-type: none"> <li>Used to monitor other data at the same time as the data allocated to Analog Data 1 or Temperature Data 1.</li> <li>Select one type of data from analog/temperature input value, peak value, bottom value, top value, valley value, or rate of change.</li> </ul> <p><b>Note</b> The temperature difference detection function can be used to detect differences between the value in an input word and Temperature Data 2.</p>	114 118 (for 1/100 display of Temperature Data, see note)
Generic Status Flags (1 input byte)	Used to allocate the Network Voltage Monitor Flag, the Unit Conduction Time Monitor Flag, and the Cumulative Counter Flag.	121
Top/Valley Detection Timing Flags (2 input bytes)	Top/Valley Detection Timing Flags are allocated in one word. These flags are used to time reading the values held as the top and valley values when both the top and valley values are allocated at the same time.	122
Analog Status Flags (4 input bytes)	Used to allocate the bits for the Comparator Result Flag, Top/Valley Detection Timing Flag and Off-wire Detection Flag. The function of each bit is as follows: <ul style="list-style-type: none"> <li>Comparator Result Flags Allow control of the judgement results only, without allocating analog values</li> <li>Top/Valley Detection Timing Flags Used to time reading the values held as the top and valley values when both the top and value values are allocated at the same time.</li> <li>Off-wire Detection Flags Disconnections can be detected even when the analog values are not allocated.</li> </ul>	134

**Note** Always set the connection path with the Configurator when the display mode is set to 1/100 display mode on the Unit's DIP switch. If the "normal display" I/O data is selected with the configurator, the temperature data allocated in the I/O data will be 0.

#### Individual Output Data

I/O data	Details	Assembly Instance No.
Hold Flags (1 output byte)	Used with each of the hold functions (peak, bottom, top, and valley) to control the execution timing of hold functions from the Master.	190

**Fixed I/O Data Combinations (DRT2-AD04 and DRT2-AD04H)**

I/O Data Type	Details	Assembly Instance No.
Analog Data 1 + Analog Data 2 (16 input bytes)	Allocation of Analog Data 1 followed by Analog Data 2.	144
Top/Valley Detection Timing Flags + Generic Status Flags (3 input bytes)	Allocation of the Top/Valley Detection Timing Flags followed by the Generic Status Flags.	151
Analog Status Flags + Generic Status Flags (5 input bytes)	Allocation of the Analog Status Flags followed by the Generic Status Flags.	164
Analog Data 1 + Top/Valley Detection Timing Flags (10 input bytes)	Allocation of Analog Data 1 followed by the Top/Valley Detection Timing Flags.	174
Analog Data 1 + Top/Valley Detection Timing Flags + Generic Status Flags (11 input bytes)	Allocation of Analog Data 1 followed by Top/Valley Detection Timing Flags and then the Generic Status Flags.	184

**Fixed I/O Data Combinations (DRT2-TS04T and DRT2-TS04P)**

I/O Data Type	Details	Assembly Instance No.
Temperature Data 1 + Temperature Data 2 16 input bytes (Normal display) 32 input bytes (1/100 display)	Allocation of Temperature Data 1 followed by Temperature Data 2.	144 (Normal display) 148 (1/100 display)
Top/Valley Detection Timing Flags + Generic Status Flags (3 input bytes)	Allocation of the Top/Valley Detection Timing Flags followed by the Generic Status Flags.	151
Analog Status Flags + Generic Status Flags (5 input bytes)	Allocation of the Analog Status Flags followed by the Generic Status Flags.	164
Temperature Data 1 + Top/Valley Detection Timing Flags 10 input bytes (Normal display) 18 input bytes (1/100 display)	Allocation of Temperature Data 1 followed by the Top/Valley Detection Timing Flags.	174 (Normal display) 178 (1/100 display)
Analog Data 1 + Top/Valley Detection Timing Flags + Generic Status Flags 11 input bytes (Normal display) 19 input bytes (1/100 display)	Allocation of Temperature Data 1 followed by Top/Valley Detection Timing Flags and then the Generic Status Flags.	184 (Normal display) 188 (1/100 display)

**Note** Data can be allocated using other data combinations, but only when an OMRON CS/CJ-series Master Unit is used because the settings are made in the Master Unit.

**Analog Output Terminals**

Analog Output Terminals support one type of input data and output data each. Allocate the required data as shown in the following tables.

**Input Data**

Data Type	Details	Assembly Instance No.
Generic Status Flags (1 input byte)	Used to allocate the Network Voltage Monitor Flag, the Unit Conduction Time Monitor Flag, and the Cumulative Counter Flag.	121

**Output Data**

Data Type	Details	Assembly Instance No.
Output data (4 output bytes)	Used to allocate analog output data.	192

### 7-1-7 Allocating I/O Data in the Master

I/O is allocated in the Master using the methods shown in the following table. Select the appropriate method depending on whether the allocated area in the Master is fixed or user-defined, and whether the allocated I/O data is the default I/O, a selected combination of data, or user-defined data.

Allocation method		I/O data that can be allocated in the Master
Allocated area in Master	Allocated I/O data	
Fixed allocations	1. Default I/O data allocation	Allocates only analog/temperature input values for 4 points.
	2. Using Configurator to select I/O data (patterns) by editing the Slave's device parameters (fixed I/O data combinations)  <b>Note</b> Settings from the Master are supported by CJ/CS-series DeviceNet Units only.	The following 11 types of I/O data can be allocated by selecting from the pull-down menu for the Slave's default connection path. <ul style="list-style-type: none"> <li>• Analog Data 1 or Temperature Data 1</li> <li>• Analog Data 2 or Temperature Data 2</li> <li>• Generic Status Flags</li> <li>• Top/Valley Detection Timing Flags</li> <li>• Analog Status Flags</li> <li>• Analog Data 1 + Analog Data 2 or Temperature Data 1 + Temperature Data 2</li> <li>• Top/Valley Detection Timing Flags + Generic Status Flags</li> <li>• Analog Status Flags + Generic Status Flags (5 input bytes)</li> <li>• Analog Data 1 or Temperature Data 1 + Top/Valley Detection Timing Flags</li> <li>• Analog Data 1 or Temperature Data 1 + Top/Valley Detection Timing Flags + Generic Status Flags</li> <li>• Hold Flags</li> </ul>
User allocations	1. Default I/O data allocation	(Same as fixed allocations.)
	2. Using Configurator to select I/O data (patterns) by editing the Slave's device parameters (fixed I/O data combinations)	(Same as fixed allocations.)
	3. Using Configurator to select I/O data for each connection by editing the Master's device parameters and allocating each data to user-defined addresses (user-defined I/O data combinations)  <b>Note</b> Supported by CJ/CS-series DeviceNet Units only.	The following 11 types of I/O data can be allocated by selecting up to two types from the pull-down menu for the Master's connection path. <ul style="list-style-type: none"> <li>• Analog Data 1 or Temperature Data 1</li> <li>• Analog Data 2 or Temperature Data 2</li> <li>• Generic Status Flags</li> <li>• Top/Valley Detection Timing Flags</li> <li>• Analog Status Flags</li> <li>• Analog Data 1 + Analog Data 2</li> <li>• Top/Valley Detection Timing Flags + Generic Status Flags</li> <li>• Analog Status Flags + Generic Status Flags</li> <li>• Analog Data 1 or Temperature Data 1 + Top/Valley Detection Timing Flags</li> <li>• Analog Data 1 or Temperature Data 1 + Top/Valley Detection Timing Flags + Generic Status Flags</li> <li>• Hold Flags</li> </ul>

**Note** For details on the data allocation patterns and methods, refer to 7-4-2 I/O Data Allocation Methods.



7-1-8 Procedure for Allocating I/O in the Master

Application		Step 1	Step 2	Step 3	
		Enable/disable functions	Select analog data	1. Allocate I/O data in fixed combinations	2. Allocate user-defined data in user-defined area
		Set using the Configurator in the Slave's Edit Device Parameters Window		Set using the Configurator under <i>Default Connection Path</i> in the Slave's Edit Device Parameters Window	Set using the Configurator under the Connection Tab in the Master's Edit Device Parameter Window
Allocating analog input only in the Master	Using default allocation	Not required.	Not required.	Not required.	---
	Scaling with desired industry unit	Set the scaling function.	Not required.	Not required.	---
	Averaging external analog inputs	Set the moving average processing operation.	Not required.	Not required.	---
Allocating other values (not analog input) in the Master	Allocating the maximum (peak) or minimum (bottom) value in the Master	Set the peak/bottom hold function.	Allocate the maximum (peak) or minimum (bottom) value as Analog Data 1, Analog Data 2, Temperature Data 1, or Temperature Data 2.	Select an I/O data (pattern) that includes either Analog Data 1, Analog Data 2, Temperature Data 1, or Temperature Data 2, and select the Hold Flag.	Specify either Analog Data 1, Analog Data 2, Temperature Data 1, or Temperature Data 2, and the Hold Flag.
	Allocating the top or valley value in the Master	Set the top/valley hold function.	Allocate the top or valley value as Analog Data 1, Analog Data 2, Temperature Data 1, or Temperature Data 2.	Select an I/O data (pattern) that includes Analog Data 1, Analog Data 2, Temperature Data 1, or Temperature Data 2, and select the Hold Flag.	Specify either Analog Data 1, Analog Data 2, Temperature Data 1, or Temperature Data 2, and the Hold Flag.
	Allocating top or valley timing in the Master	Set the top/valley hold function.	Not required.	Select an I/O data (pattern) that includes the Top/Valley Detection Timing Flag, and select the Hold Flag.	Specify the Top/Valley Detection Timing Flag and the Hold Flag.
	Allocating the rate of change in the Master	Set the rate of change operation function.	Allocate the rate of change value in Analog Data 1, Analog Data 2, Temperature Data 1, or Temperature Data 2.	Select an I/O data (pattern) that includes Analog Data 1, Analog Data 2, Temperature Data 1, or Temperature Data 2.	Specify either Analog Data 1, Analog Data 2, Temperature Data 1, or Temperature Data 2.
Allocating the alarm output for analog input, peak/bottom, top/valley, or rate of change value in the Master		Set the HH, H, L, and LL alarms for the comparator function.	Allocate any of the analog data types in Analog Data 1 or Temperature Data 1.	Select an I/O data (pattern) that includes the Analog Status Flags.	Specify the Analog Status Flags.
Monitoring the cumulated value from the Configurator.		Set the cumulative count function.	Not required.	Not required.	Not required.

### 7-1-9 Application Procedure Flowchart

#### Analog Input Terminals

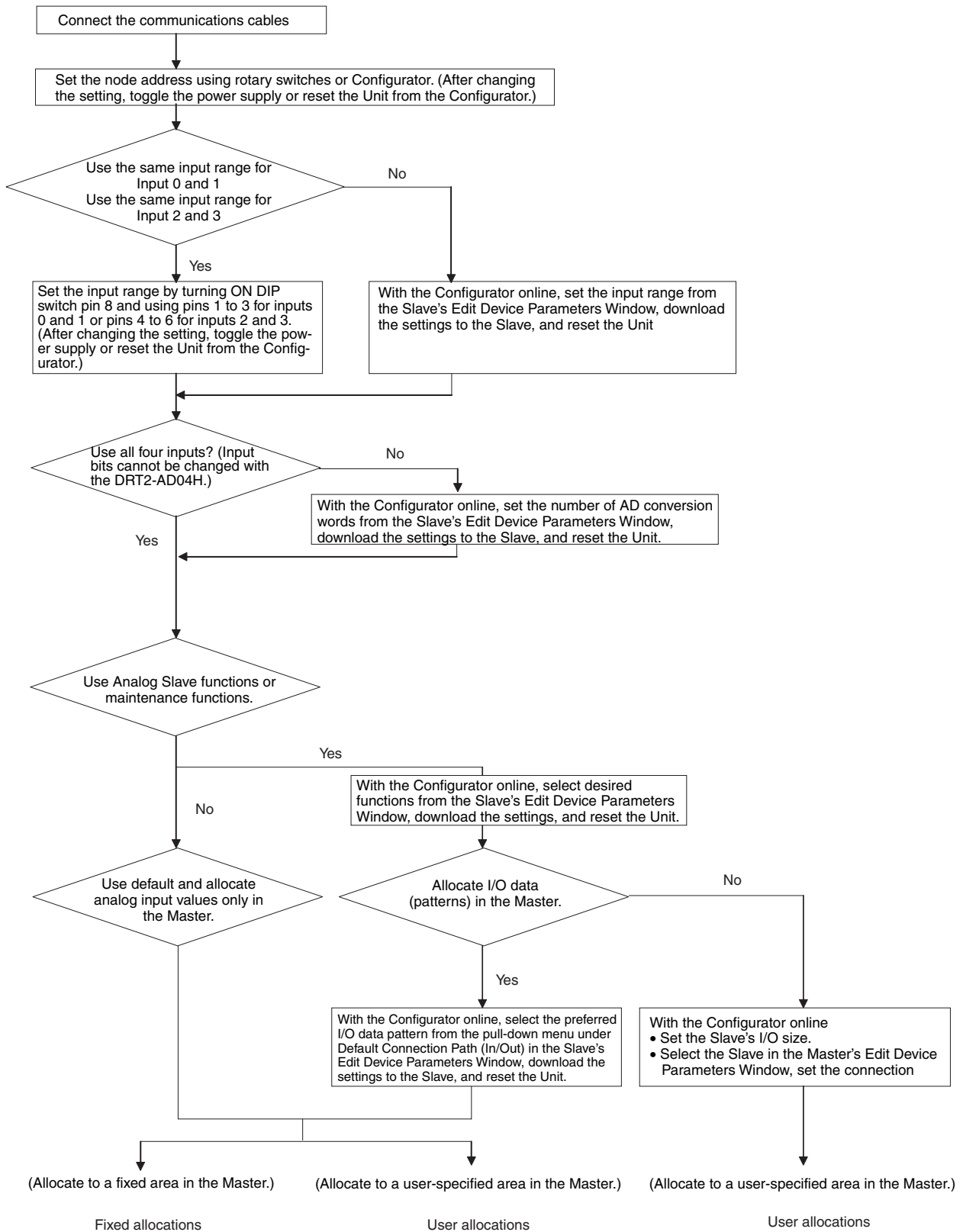

### Analog Output Terminals

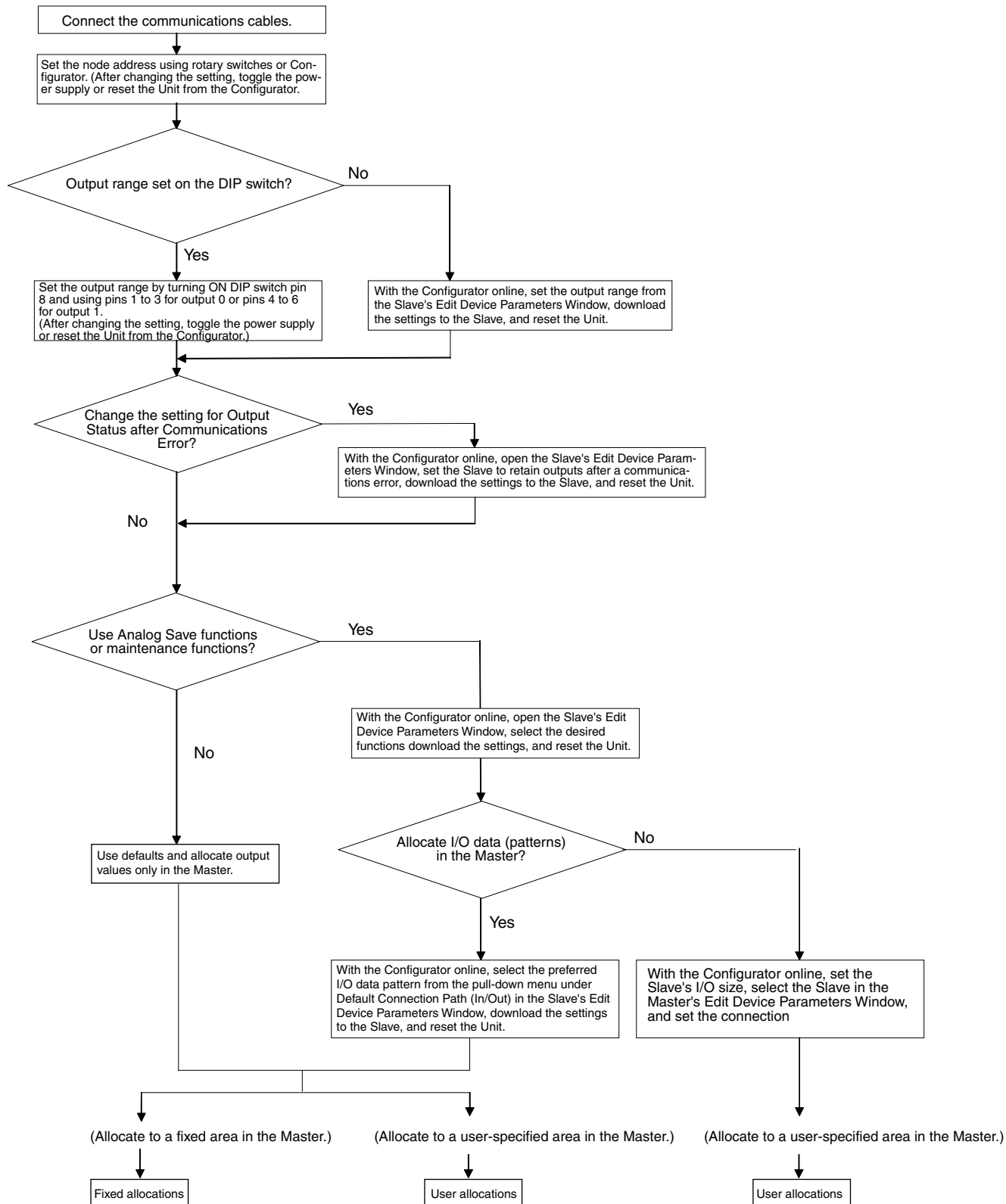

### Temperature Input Terminals

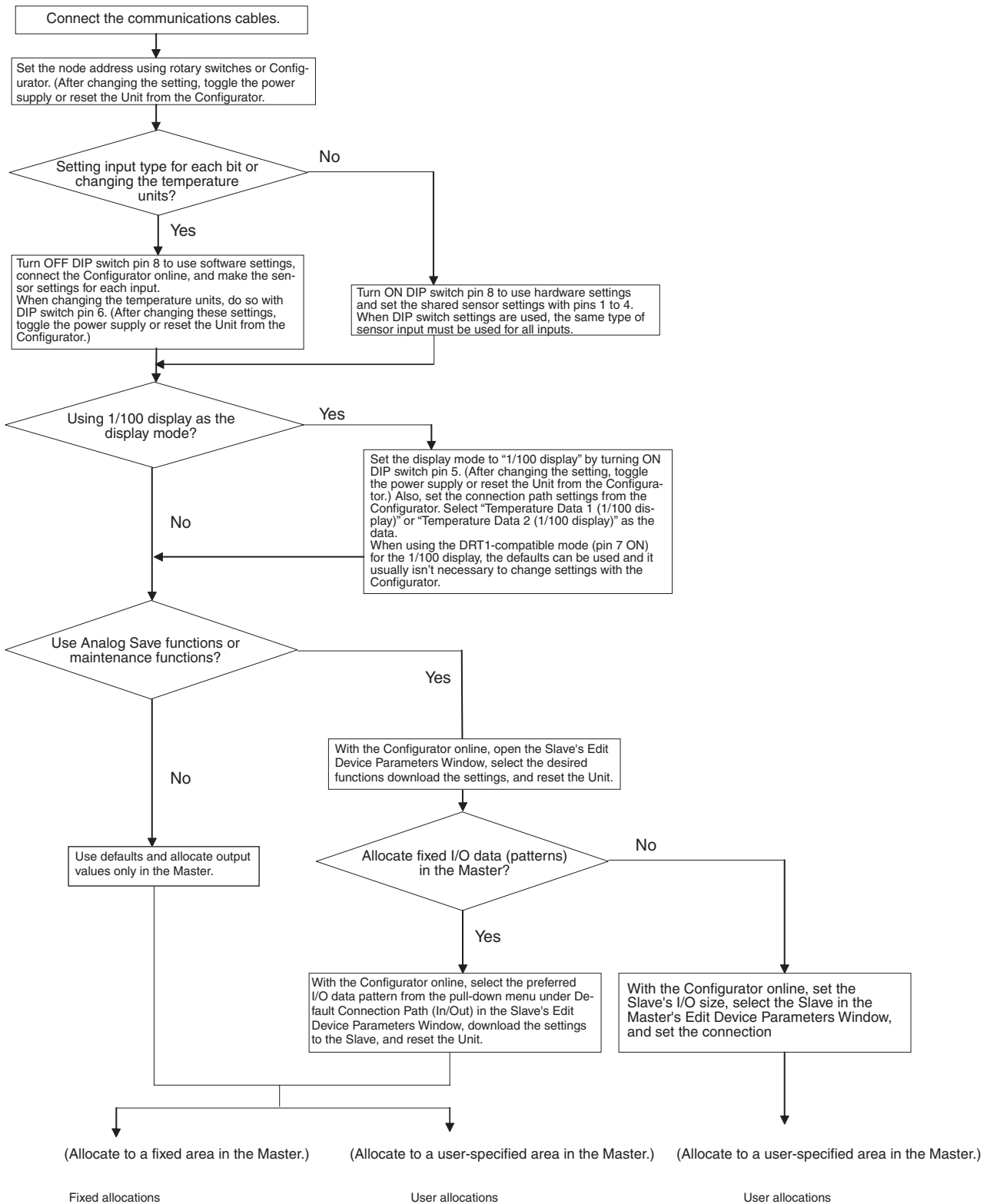

## 7-2 Common Procedures

### 7-2-1 Connecting Communications Cables

Communications cables are connected using the same methods as for General-purpose Slaves. Refer to *5-2 Connecting Communications Cables to General-purpose Slaves* for details.

### 7-2-2 Node Address and Baud Rate Settings

The Analog Slaves' node address and baud rate settings are described here.

Node address setting: Use rotary switch or the Configurator

Baud rate setting: Automatically detected from the Master

#### Node Address Settings

The node address of the Analog Slave is set as a decimal value using the left rotary switch for the ten's digit and the right rotary switch for the one's digit. (Up to 63 nodes can be set.)

Node addresses 64 to 99 can be set using the Configurator using the following method.

**Note** The rotary switch settings are read when the power is turned ON.

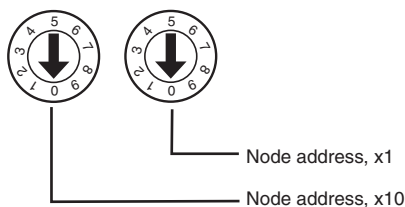

#### Setting Node Addresses Using the DeviceNet Configurator

- 1,2,3... 1. Click the right mouse button over the icon of the corresponding DRT2 Analog Slave in the Network Configuration Window, and select **Change Node Address**.

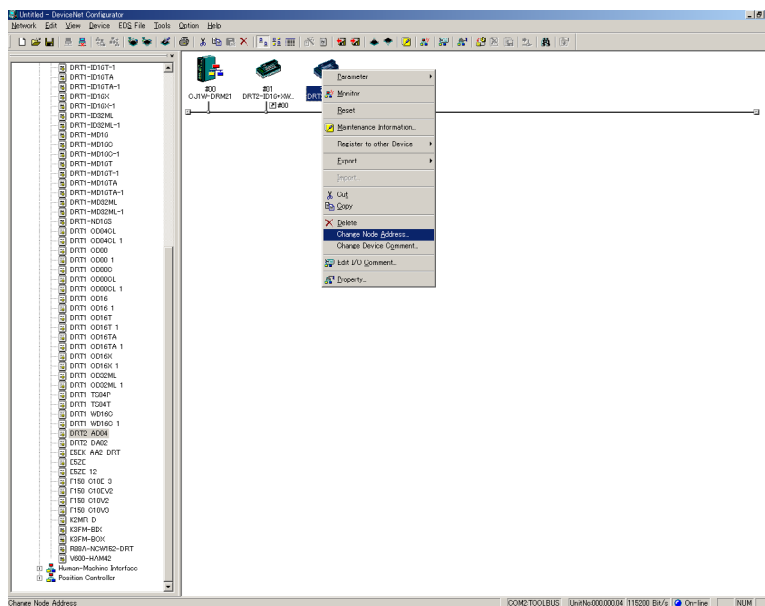

2. The following window will be displayed. Enter the node address.

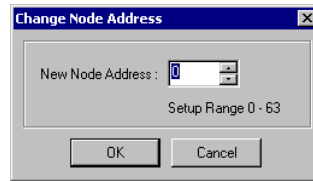

3. Click the **OK** Button.

**Note** Any node address within the setting range can be used as long as it is not already set for another node. Setting the same node address for more than one node will cause a node address duplication error and communications will not start.

## **Baud Rate Setting**

The baud rate of the system is determined by the baud rate set for the Master Unit (automatic detection). Setting the baud rate for each Unit is not required.

## **7-2-3 Mounting in Control Panels**

An Analog Slave can be mounted in a control panel using the following method.

### **Using DIN Track**

Mount the back of the Slave to a 35-mm DIN Track. To mount the Slave, pull down on the mounting hook on the back of the Unit with a screwdriver, latch the DIN Track onto the back of the Slave, and then secure the Slave to the DIN Track. Secure the Slaves by mounting End Plates on both sides of them.

### **Connecting End Plates**

Hook the bottom of the End Plates onto the DIN Track, as shown at (1) in the following diagram, then hook the top of the End Plates as shown at (2).

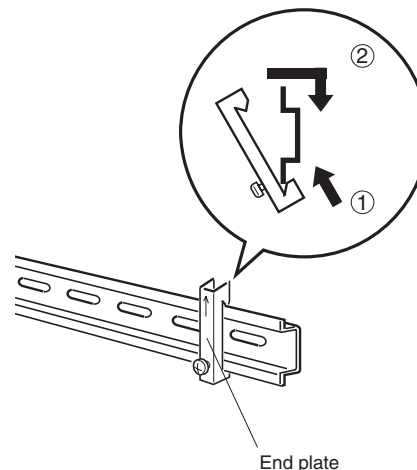

**Note** Always attach End Plates to both ends of Slaves connected to the DIN Track.

### **Mounting Direction**

Unless specific restrictions are given for the Slave, it can be mounted in any of the following six directions. The input accuracy of the DRT2-TS04T depends on the mounting method in some cases (see note).

**Note** The input accuracy of a DRT2-TS04T is slightly less accurate if mounted vertically or facing down (mounting direction 3, 4, or 6 below) when the DRT2-TS04T is used to replace another Temperature Input Terminal and the existing Terminal Block is left in place. For details, refer to the *Performance*

Specifications in 7-6-1 DRT2-TS04T and DRT2-TS04P Temperature Input Terminals.

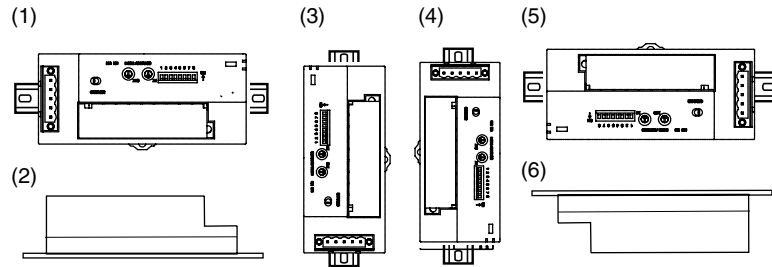

## 7-2-4 Wiring the I/O Lines

The I/O lines are all wired to M3 screw terminals.

Connect M3 crimp terminals to the wires and then connect them to the Terminal Block.

Tighten the screws to a torque of 0.5 N·m.



## 7-3 Maintenance Information Window

This section describes the Maintenance Information Window, which can be used to monitor the status of Analog Slaves. The Monitor Device Window can be used to check the same Slave status information, but the examples in this section uses the Maintenance Information Window. Refer to 4-1-2 *Maintenance Mode Window* for details on the differences between the Maintenance Information Window and the Monitor Device Window.

### 7-3-1 Checking Maintenance Information

The Maintenance Mode Window can be opened in two ways.

1. Right-click the Main Window to display the popup menu and select **Maintenance Information**.
2. Open the Maintenance Mode Window and double-click the desired Slave's icon.

**General Window**

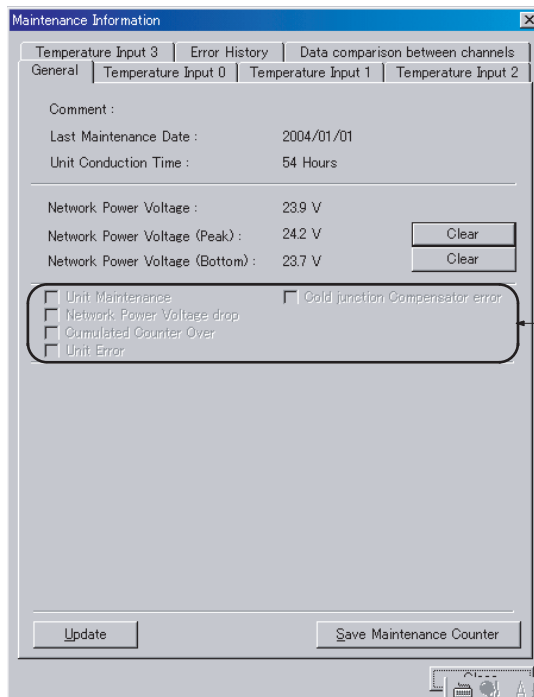

**Note** This explanation in this example uses a Temperature Input Terminal’s Maintenance Information Window. The Tab name will be “Analog Input □” or “Analog Output □” for an Analog Terminal’s Maintenance Information Window.

Item	Description
Comment	Displays up to 32 characters of text set as the Unit comment.
Last Maintenance Date	Displays the last maintenance date that was set.
Unit Conduction Time	Displays the total time that the Unit has been ON (cumulative power ON time).
Network Power Voltage	Displays the present network power supply voltage.
Network Power Voltage (Peak)	Displays the maximum power supply voltage up to the present time.
Network Power Voltage (Bottom)	Displays the minimum power supply voltage up to the present time.
Update Button	Click this Button to update the Maintenance information.
Save Maintenance Counter	This function saves the Maintenance counter value in the Unit. If this function is used, the previous value will be retained when the power supply is turned OFF and ON again.

**Note** Always update the information when the parameters have been edited or set.

**Status Check Boxes**

The flags (check boxes) shown in the following table will be turned ON when the corresponding error occurs.

Item	Description
Unit Maintenance	ON when the total Unit ON time exceeds the set value.
Network Power Voltage drop	ON when the network power supply voltage falls below the set value.
Cumulated Counter Over	ON when any one of the input’s cumulative counter values exceeds the set value.



Item	Description
Unit Error	ON when a Unit Error has occurred in an Analog Unit.
Cold junction Compensator error (DRT2-TS04T only)	ON when there is an error in the cold junction compensator.

**Individual Temperature Input Windows**

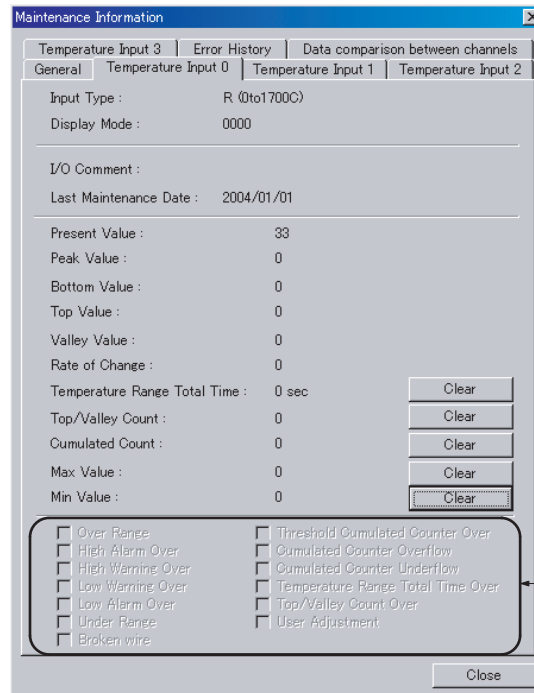

**Display Area**

Item	Description
Input Type	Shows the present input sensor type. (DRT2-TS04□ only)
Display Mode	Indicates the number of digits displayed. (DRT2-TS04□ only) 0000: No decimal point 0000.0: Decimal point and significant digits to 0.1 0000.0: Decimal point and significant digits to 0.01
I/O Comment	Displays up to 32 characters of text as a comment. A separate comment can be set for each input.
Last Maintenance Date	Displays the last maintenance date that was set. (All models.)
Present Value	Displays the present analog value. (All models.) Displays values derived from the analog value, including the Peak, Bottom, Top, and Valley values, and Rate-of-change (DRT2-AD04□ and DRT2-TS04□), the Temperature Range Total Time and Top/Valley Count (DRT2-TS04□ only), and the Cumulated Count. For details, refer to each function's explanation and settings.

Status Check Boxes

**Status Boxes Displayed for All Analog Slaves**

Item	Description
Threshold Cumulated Counter Over	ON when the cumulative counter value exceeds the set value.
Cumulated Counter Overflow	ON when there is an overflow in the cumulative counter value.
Cumulated Counter Underflow	ON when there is an underflow in the cumulative counter value.

**Status Boxes Displayed for the DRT2-AD04□ and DRT2-TS04□ Only**

Item	Description
Over Range/Under Range	ON when the analog data is above or below the displayable range.
Alarm Over/Warning Over	ON when the analog data is above or below the monitoring set values set in the comparator function.
Broken wire	ON when a wire is broken or disconnected. (Used only for Analog Input Terminals when the input range is 1 to 5 V or 4 to 20 mA.)

**Status Boxes Displayed for the DRT2-TS04□ Only**

Item	Description
Temperature Range Total Time Over	ON when the present value being counted in the set range exceeds the monitoring set value.
Top/Valley Count Over	ON when the top or valley count exceeds the monitoring set value.
User Adjustment	ON when the user-set adjustment function is operating.

**Data Comparison between Channels Window (DRT2-TS04□ Only)**

Each comparison number (No.) corresponds to the comparison of a pair of inputs.

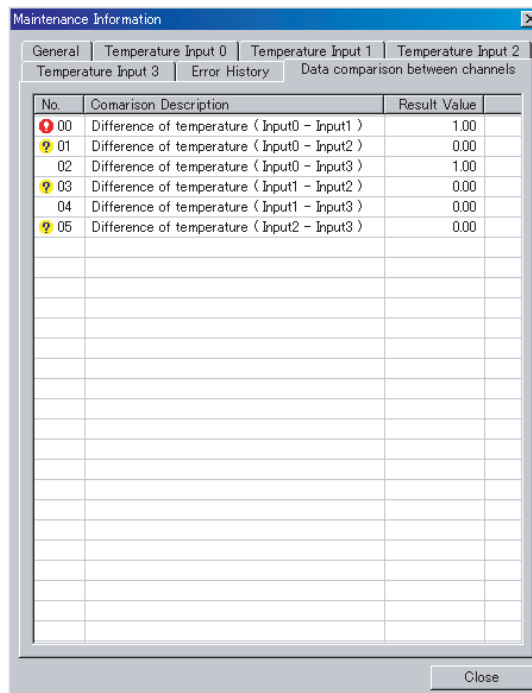

Item	Description
Comparison Description	Displays the inputs used in the error calculation.
Result Value	Displays the calculation results.

- Note**
1. When a result value exceeds the monitoring set value, a red alarm icon will be displayed to the left of the comparison number (No.).
  2. When either of the comparison inputs is disconnected (off-wire detected), the result value will be set to 0.00 and a yellow alarm icon will be displayed to the left of the comparison number (No.).

**Error History Window**

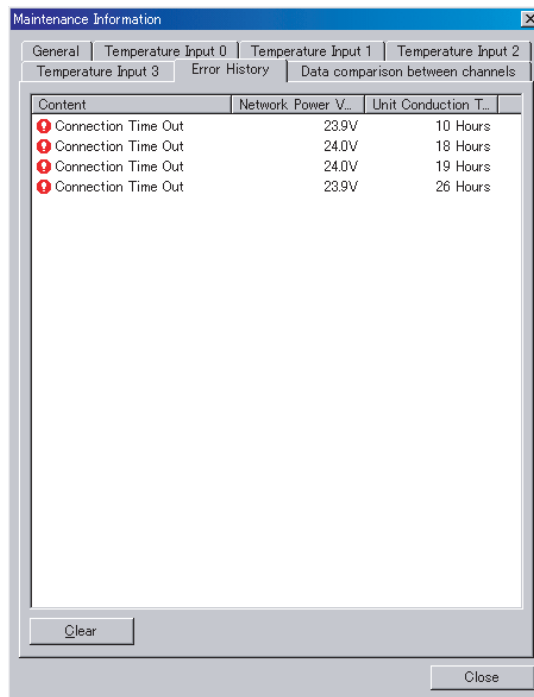

Item	Description
Content	Displays the contents of the communications errors that occurred.
Network Power Voltage	Displays the power supply voltage being supplied when the error occurred.
Unit Conduction Time	Displays the total time that the network power supply had been ON when the error occurred. DRT2-TS04□ only)
Clear Button	Clears the error history.

## 7-4 Analog Input Terminals

### 7-4-1 DRT2-AD04 and DRT2-AD04H Analog Input Terminals

#### General Specifications

Item	Specifications
Communications power supply voltage	11 to 25 V DC (Supplied from the communications connector.)
Current consumption	DRT2-AD04: 90 mA max. (24 V DC) DRT2-AD04H: 70 mA max. (24 V DC)
Noise immunity	Conforms to IEC61000-4-4. 2 kV (power lines)
Vibration resistance	10 to 150 Hz, 0.7-mm double amplitude
Shock resistance	150 m/s <sup>2</sup>
Dielectric strength	500 V AC for 1 min. with 1-mA sensing current (between isolated circuits)
Ambient temperature	−10 to +55°C
Ambient humidity	25% to 85% (with no condensation)
Operating environment	No corrosive gases
Storage temperature	−25 to +65°C
Mounting	35-mm DIN Track mounting
Mounting strength	50 N In the direction of the Track: 10 N
Screw tightening torque	M3 (power supply, I/O terminals): 0.5 N·m
Weight	DRT2-AD04: 170 g max. DRT2-AD04H: 160 g max.

#### Performance Specifications

##### DRT2-AD04

Item	Specifications		
	Voltage input	Current input	
Input points	4 points (Inputs 0 to 3)		
Input signal range	0 to 5 V 1 to 5 V 0 to 10 V −10 to 10 V	0 to 20 mA 4 to 20 mA	
Input range setting method	<ul style="list-style-type: none"> <li>DIP switch: Inputs 0 and 1 share same setting, and Inputs 2 and 3 share same setting.</li> <li>Configurator: Inputs 0 to 3 set separately.</li> </ul>		
Maximum signal input	±15 V	±30 mA	
Input impedance	1 M Ω min.	Approximately 250 Ω	
Resolution	1/6,000 (full scale)		
Overall accuracy	25°C	±0.3% FS	±0.4% FS
	−10 to 55°C	±0.6% FS	±0.8% FS
Analog conversion cycle	4 ms max./ 4 points <b>Note</b> When the DeviceNet communications cycle is 4 ms and math operations are not used.		
AD conversion data	−10 to 10 V range: F448 to 0BB8 hex full scale (−3,000 to 3,000) Other ranges: 0000 to 1770 hex full scale (0 to 6,000) AD conversion range: ±5% FS of the above data ranges.		
Isolation method	Photocoupler isolation (between input and communications lines) No isolation between input signal wires		

Item	Specifications	
	Voltage input	Current input
I/O connection method	Terminal-block connection	
Standard accessories	4 short bars for current input	

**DRT2-AD04H**

Item	Specifications	
	Voltage input	Current input
Input points	4 points (Inputs 0 to 3)	
Input signal range	0 to 5 V 1 to 5 V 0 to 10 V	0 to 20 mA 4 to 20 mA
Input range setting method	<ul style="list-style-type: none"> <li>• DIP switch: Inputs 0 and 1 share same setting, and Inputs 2 and 3 share same setting.</li> <li>• Configurator: Inputs 0 to 3 set separately.</li> </ul>	
Maximum signal input	±15 V	±30 mA
Input impedance	1 MΩ min.	Approximately 250 Ω
Resolution	1/30,000 (full scale)	
Overall accuracy	25°C	±0.3% FS
	-10 to 55°C	±0.6% FS
±0.8% FS		
Analog conversion cycle	4 points/250 ms max.	
AD conversion data	0000 to 7530 hex full scale AD conversion range: ±5% FS of the above data ranges.	
Isolation method	Photocoupler isolation (between input and communications lines and between input signal wires)	
I/O connection method	Terminal-block connection	
Standard accessories	4 short bars for current input	

**Names and Functions of Parts**

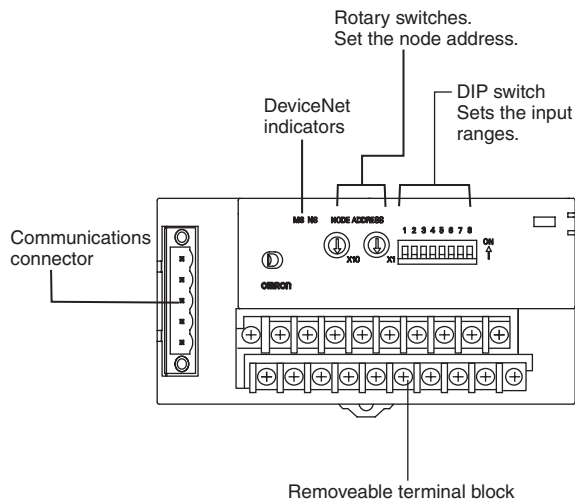

**Setting the Input Signal Range**

**Setting with the DIP Switch**

The input range can be set using the DIP switch or the Configurator.

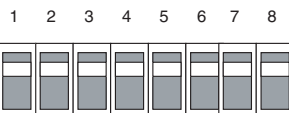

Each pin is set according to the following table.

Pin No.	Setting	Specifications
1	Input Terminal: Input range setting for Inputs 0 and 1.	Default setting: All pins OFF
2		
3		
4	Input Terminal: Input range setting for Inputs 2 and 3.	Default setting: All pins OFF
5		
6		
7	AD conversion data format setting	ON: Signed binary OFF: Two's complement
8	Range setting method	OFF: Use Configurator. ON: Use DIP switch. The other DIP switch settings are disabled when pin 8 is OFF. Default setting: OFF

- Note**
1. When using the DRT2-AD04H, always set pin 7 to its default setting (OFF).
  2. Always set pin 8 to ON if the DIP switch is used to set the ranges. If this pin is OFF, the DIP switch settings will not be enabled.
  3. The DIP switch settings are read when the power is turned ON.

**Input Range Settings**

■ **Inputs 0 and 1 (Shared Setting)**

Signal range	Pin 1	Pin 2	Pin 3
0 to 5 V	OFF	OFF	OFF
1 to 5 V	ON	OFF	OFF
0 to 10 V	OFF	ON	OFF
-10 to 10 V	ON	ON	OFF
4 to 20 mA	OFF	OFF	ON
0 to 20 mA	ON	OFF	ON
Cannot set for other ranges.	---	---	---

■ **Inputs 2 and 3 (Shared Setting)**

Signal range	Pin 4	Pin 5	Pin 6
0 to 5 V	OFF	OFF	OFF
1 to 5 V	ON	OFF	OFF
0 to 10 V	OFF	ON	OFF
-10 to 10 V	ON	ON	OFF
4 to 20 mA	OFF	OFF	ON
0 to 20 mA	ON	OFF	ON
Cannot set for other ranges.	---	---	---

- Note**
1. When the DIP switch is used to set the input ranges (pin 8 ON), the input signal ranges will always be the same for Inputs 0 and 1 and for Inputs 2 and 3. If it is necessary to set separate input signal ranges for Inputs 0 to 3, use the Configurator to make the settings rather than the DIP switch. When pin 8 is OFF, the other DIP switch settings are disabled.
  2. When all the four inputs (inputs 0 to 3) are not being used in the DRT2-AD04, the number of AD conversion points can be set using the Configurator to speed up the conversion cycle for each input. Refer to *7-4-3 Functions and Settings* and *7-4-4 Calculating the Conversion Cycle (DRT2-AD04 Only)*.

### Setting Using the DeviceNet Configurator

Use the following procedure to set the input range for each input using the Configurator.

1,2,3...

1. Double-click the icon of the Slave to be set in the Main Window and open the Edit Device Parameters Window. (From the Maintenance Mode Window, click the right mouse button over the Slave icon and select **Parameters** and **Edit**.)
2. Select the Tab Page for the input where the range is to be changed.
3. Select the desired range from the pull-down menu in the *Input Range* field.

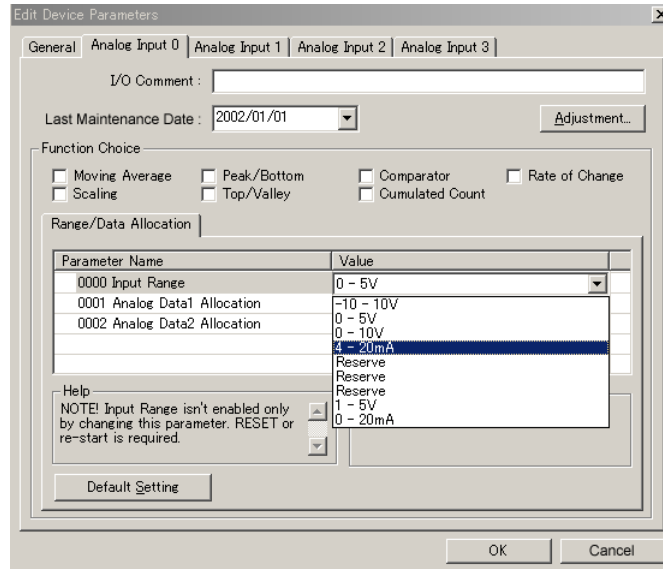

4. Return to the **General** Tab, click the **Download** Button, and then click the **Reset** Button to reset the Unit.
5. Click the **OK** Button and exit the window.

### Internal Circuits (DRT2-AD04 Only)

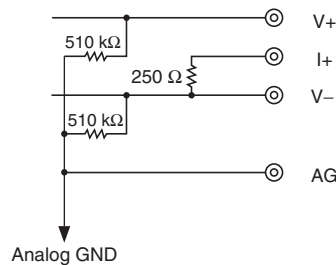

**Note** Since inputs are isolated from each other in the DRT2-AD04H, it is not necessary to be concerned with the structure of the internal circuits.

### Wiring

Connect the terminals of the Analog Input Terminal for each Input Unit according to the following diagrams, depending on whether a voltage input or a current input is being used.

DRT2-AD04

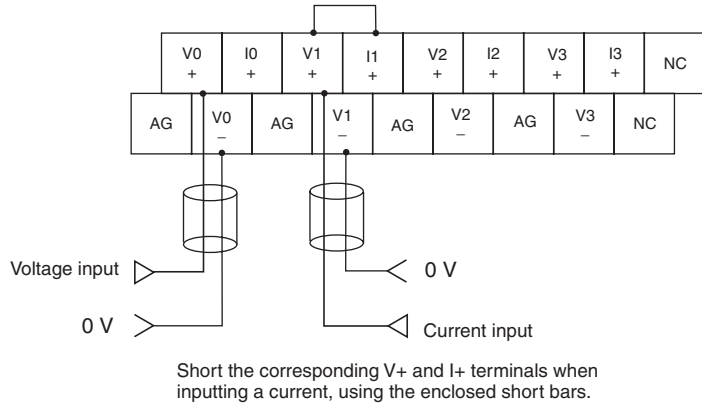

DRT2-AD04H

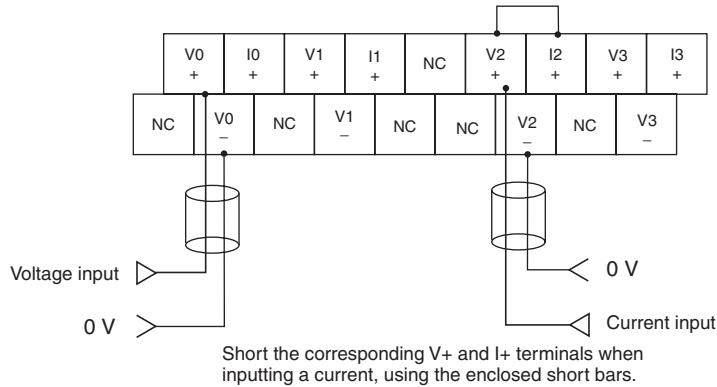

**Input Range and Conversion Data**

The analog data that is input can be converted to digital data according to the input range, as described here. If the input exceeds the input range, the AD conversion data will be fixed at the upper or Low Limit.

DRT2-AD04 Input Ranges

■ **Input Range: 0 to 5 V**

The voltage range 0 to 5 V corresponds to 0000 to 1770 hex (0 to 6,000). The convertible data range is FED4 to 189C hex (-300 to 6,300). Negative voltages are expressed as two's complements (16 bits). When a disconnection occurs, the data equivalent to 0 V input will be used (0000 hex).

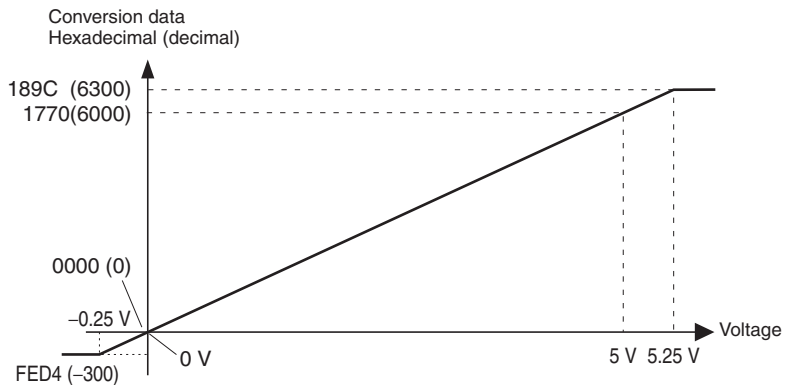



■ **Input Range: 1 to 5 V**

The voltage range 1 to 5 V corresponds to 0000 to 1770 hex (0 to 6,000). The convertible data range is FED4 to 189C hex (-300 to 6,300). If the input voltage falls below the input range (input voltage less than 0.76 V), a disconnection is detected and the data is set to 7FFF hex.

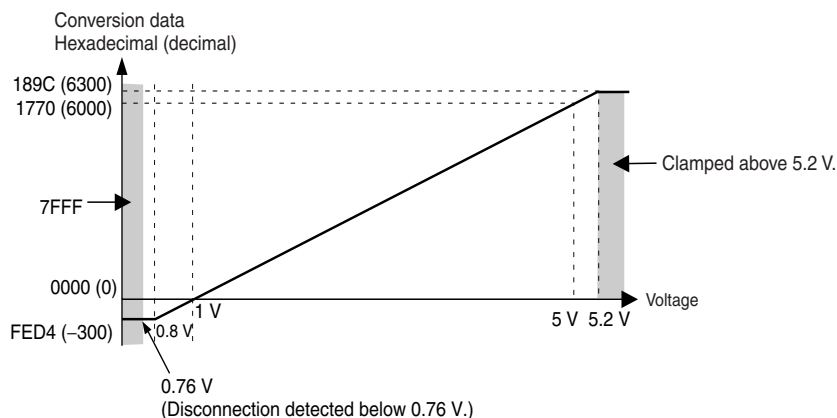

■ **Input Range: 0 to 10 V**

The voltage range 0 to 10 V corresponds to 0000 to 1770 hex (0 to 6,000). The convertible data range is FED4 to 189C hex (-300 to 6,300). Negative voltages are expressed as two's complements (16 bits). When a disconnection occurs, the data equivalent to 0 V input will be used (0000 hex).

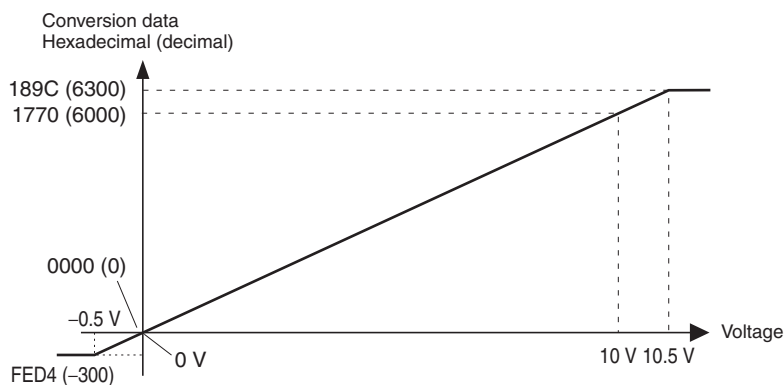

■ **Input Range: -10 to 10 V**

The voltage range -10 to 10 V corresponds to F448 to 0BB8 hex (-3,000 to 3,000). The convertible data range is F31C to 0CE4 hex (-3,300 to 3,300). Negative voltages are expressed as two's complements (16 bits). When a disconnection occurs, the data equivalent to 0 V input will be used (0000 hex).

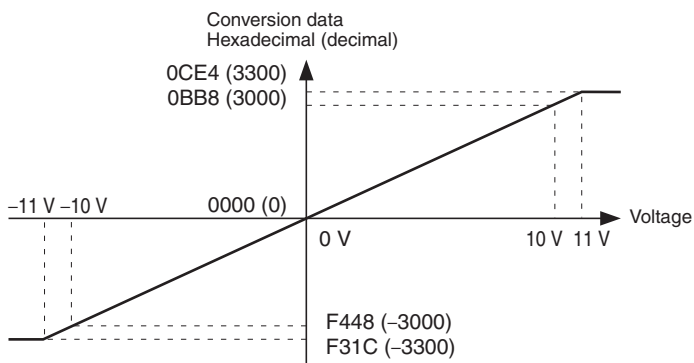

■ **Input Range: 0 to 20 mA**

The current range 0 to 20 mA corresponds to 0000 to 1770 hex (0 to 6,000). The convertible data range is FED4 to 189C hex (-300 to 6,300). Negative currents are expressed as two's complements (16 bits). When a disconnection occurs, the data equivalent to 0 mA input will be used (0000 hex).

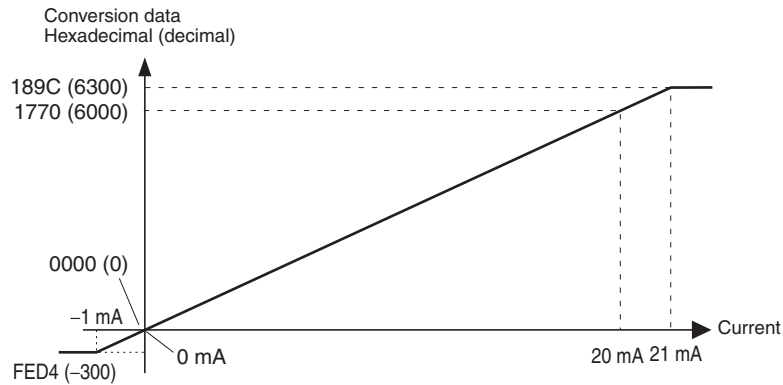

■ **Input Range: 4 to 20 mA**

The current range 4 to 20 mA corresponds to 0000 to 1770 hex (0 to 6,000). The convertible data range is FED4 to 189C hex (-300 to 6,300). If the input current is below the input range (input current less than 3.04 mA), a disconnection is detected and the data is set to 7FFF hex.

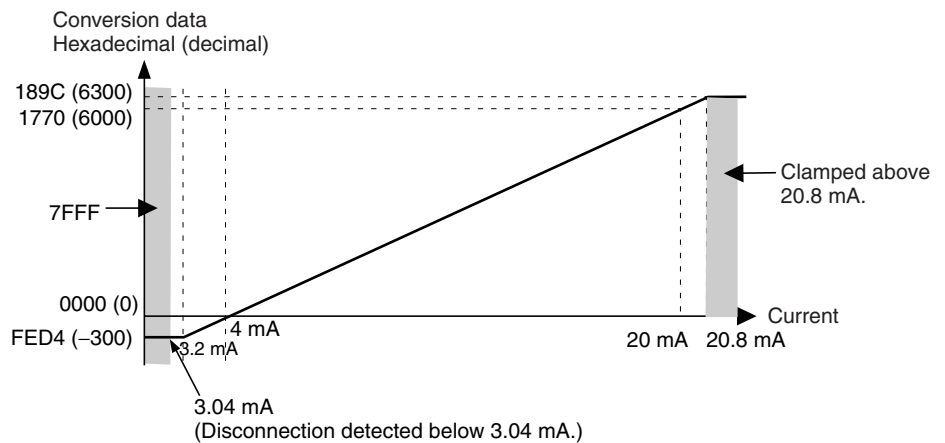

### DRT2-AD04H Input Ranges

#### ■ Input Range: 0 to 10 V

The voltage range 0 to 10 V corresponds to 0000 to 7530 hex (0 to 30,000). The convertible data range is FA24 to 7B0C hex (-1,500 to 31,500). Negative voltages are expressed as two's complements.

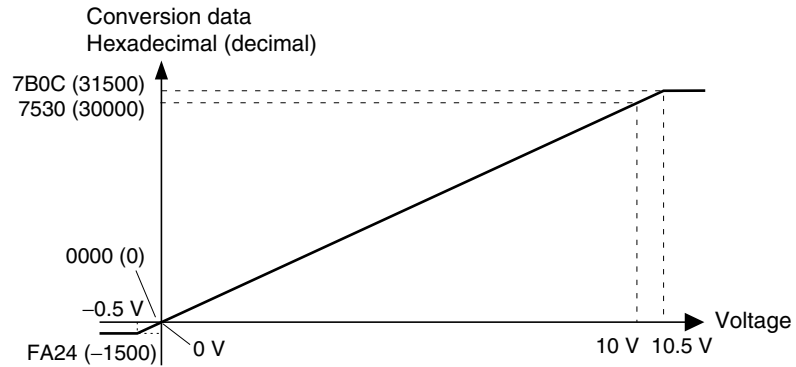

#### ■ Input Range: 0 to 5 V

The voltage range 0 to 5V corresponds to 0000 to 7530 hex (0 to 30,000). The convertible data range is FA24 to 7B0C hex (-1,500 to 31,500). Negative voltages are expressed as two's complements.

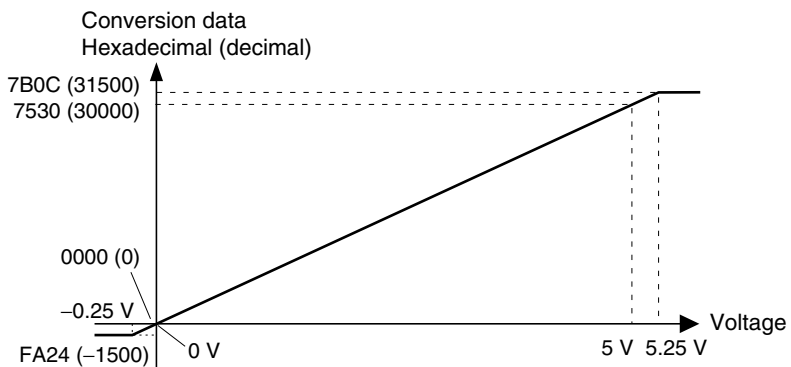

■ **Input Range: 1 to 5 V**

The voltage range 1 to 5 V corresponds to 0000 to 7530 hex (0 to 30,000). The convertible data range is FA24 to 7B0C hex (-1,500 to 31,500). The voltage range 0.8 to 1 V corresponds to FA24 to 0000 hex (-1,500 to 0). If a the input voltage falls below the input range (input voltage less than 0.76 V), a disconnection is detected and the data is set to 7FFF hex.

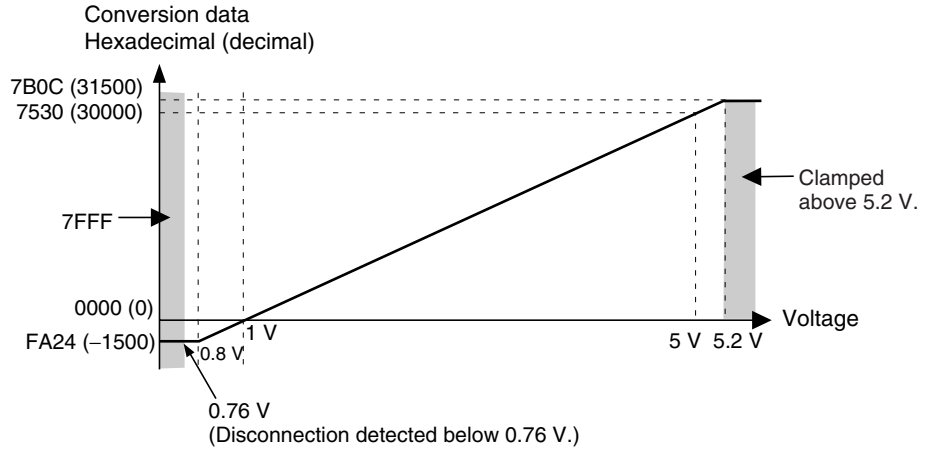

■ **Input Range: 0 to 20 mA**

The current range 0 to 20 mA corresponds to 0000 to 7530 hex (0 to 30,000). The convertible data range is FA24 to 7B0C hex (-1,500 to 31,500). Negative voltages are expressed as two's complements.

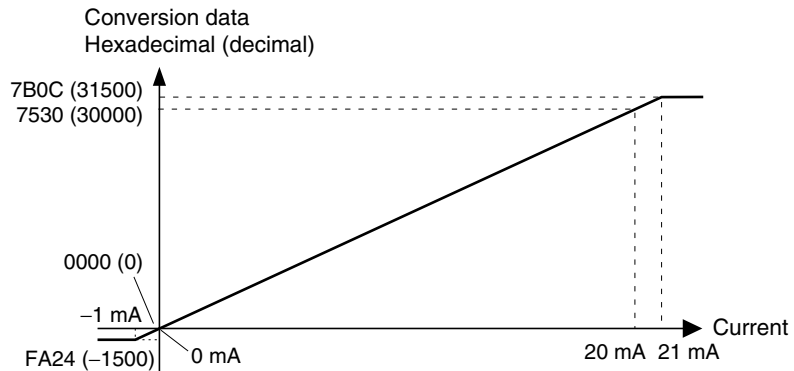

■ **Input Range: 4 to 20 mA**

The current range 0 to 20 mA corresponds to 0000 to 7530 hex (0 to 30,000). The convertible data range is FA24 to 7B0C hex (-1,500 to 31,500). The current range 3.2 to 4 mA corresponds to FA24 to 0000 hex (-1,500 to 0). If the input current is below the input range (input current less than 3.04 mA), a disconnection is detected and the data is set to 7FFF hex.

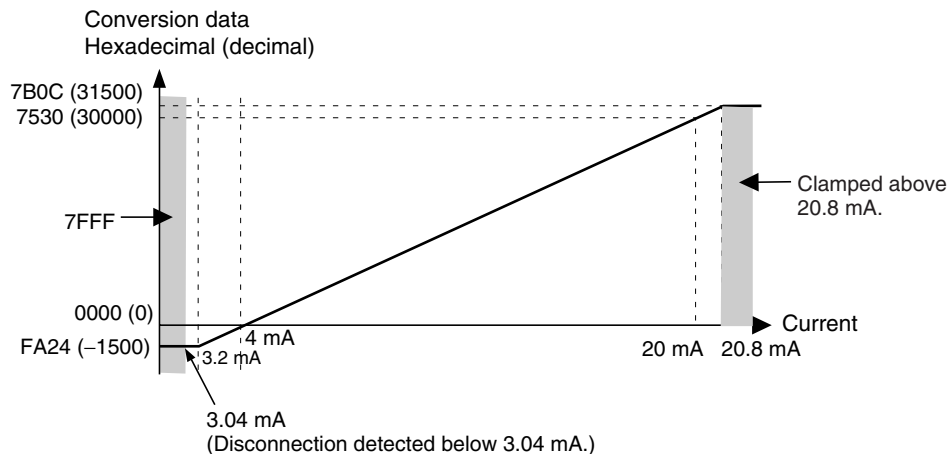

**AD Conversion Data**

Negative AD conversion data is expressed as two's complements. The NEG instruction (two's complement conversion) can be used to obtain the absolute value of the two's complement. When pin 7 of the DIP Switch is turned ON, the AD conversion data will be expressed in signed binary.

	15	14	13	12	11	10	9	8	7	6	5	4	3	2	1	0
Word +0	Input 0 AD conversion data															
Word +1	Input 1 AD conversion data															
Word +2	Input 2 AD conversion data															
Word +3	Input 3 AD conversion data															

**Conversion Speed**

**DRT2-AD04**

The AD conversion data for 4 input points is refreshed every 3.82 s max., although the conversion speed will vary depending on the functions and number of AD conversion points being used. Refer to 7-4-4 Calculating the Conversion Cycle (DRT2-AD04 Only) for details.

**DRT2-AD04H**

The AD conversion data is refreshed every 250 ms. After a step response is input, however, it may take up to 650 ms until 90% of the input value is reached and the AD conversion data can be transferred.

**Dimensions**

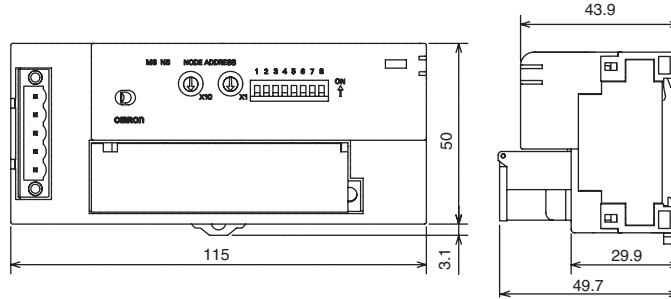

**7-4-2 I/O Data Allocation Methods**

**Selecting Analog Data**

After performing math operations, up to two of the six resulting values can be selected to allocate in the Master (one type each for Analog Data 1 and Analog Data 2). Select from analog input value, peak value, bottom value, top value, valley value, and rate of change. The selected data is allocated in the Master individually or in combination with Status Flags. The following methods can be used to select the analog data.

**Using the Configurator**

1,2,3...

1. Double-click the icon of the Analog Slave to be set in the Main Window and open the Edit Device Parameters Window. (From the Maintenance Mode Window, click the right mouse button over the Slave icon and select **Parameters** and **Edit**.)
2. Click the Tab Page for the input where analog data is to be selected. From the data on which math operations have been performed, select two types of data from the pull-down menu as Analog Data 1 and Analog Data 2.

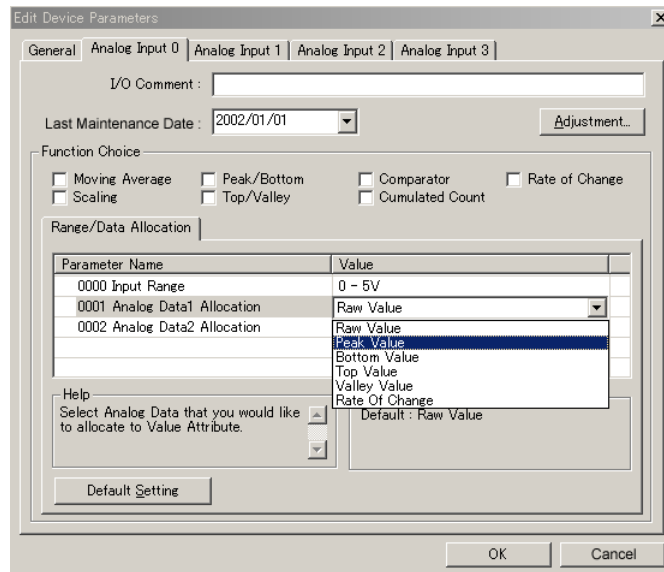

3. Return to the **General** Tab, click the **Download** Button, and then click the **Reset** Button to reset the Unit.
4. Click the **OK** Button and exit the window.

**Allocating I/O Data in the Master**

Use one of the following methods to select data for allocating in the Master and then perform remote I/O communications.

- 1,2,3...**
1. Allocating only analog input values (default I/O data) in the Master.
  2. Allocating selected I/O data (patterns) in the Master (fixed I/O data combinations).
  3. Allocating user-defined I/O data in the Master (user-defined I/O data combinations).

■ **Allocating Analog Input Values (Default I/O Data) Only**

When using the Analog Input Terminal's default settings, only the analog input values are selected as I/O data and allocated in the four words (eight bytes) of the Master's IN Area, as shown in the following diagram.

<b>15</b>		<b>0</b>
	<b>Analog input value for Input 0</b>	
	<b>Analog input value for Input 1</b>	
	<b>Analog input value for Input 2</b>	
	<b>Analog input value for Input 3</b>	

■ **Allocating Selected I/O Data (Patterns)**

The analog data selected from the data on which math operations have been performed is combined with other data such as Status Flags and allocated in the Master.

Example: Allocating Analog Data 1 + Top/Valley Detection Timing Flags in the Master.

<b>15</b>	<b>8</b>	<b>7</b>	<b>0</b>
	<b>Analog Data 1 for Input 0</b>		
	<b>Analog Data 1 for Input 1</b>		
	<b>Analog Data 1 for Input 2</b>		
	<b>Analog Data 1 for Input 3</b>		
	<b>Top Detection Timing Flag</b>	<b>Valley Detection Timing Flag</b>	

The following method can be used to allocate data from the Configurator.

**Setting Using the DeviceNet Configurator**

- 1,2,3...**
1. Double-click the icon of the Analog Slave to be set in the Main Window and open the Edit Device Parameters Window. (From the Maintenance Mode Window, click the right mouse button over the Slave icon and select **Parameters** and **Edit**.)

- Click the **General** Tab and select the desired I/O data (pattern) from the pull-down menu under the *Default Connection Path (in)* field. In the following example, Analog Data 1 and Analog Data 2 are both allocated.

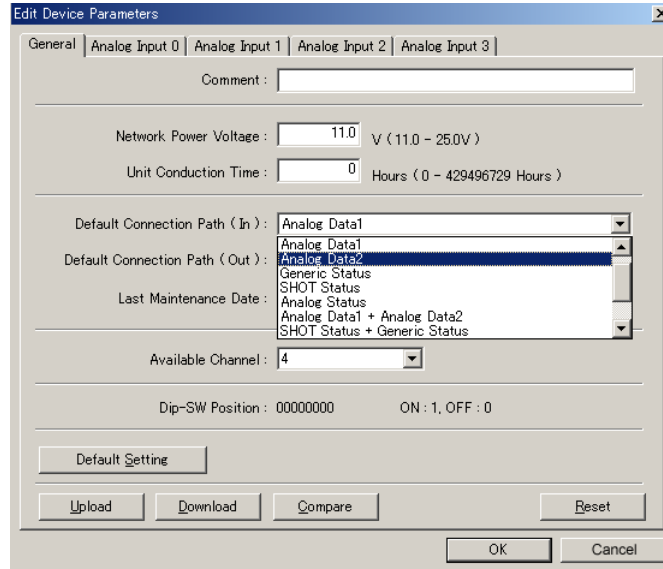

- Click the **Download** Button and then click the **Reset** Button to reset the Unit.
- Click the **OK** Button and exit the window.

#### ■ **Allocating User-defined I/O Data (Any I/O Data Combination)**

The analog data selected from the data on which math operations have been performed can be allocated in the Master with other data such as Status Flags, in any combination. The Configurator can be used to allocate two data patterns in the Master with any combination.

This method is supported by CS/CJ-series DeviceNet Master Units only.

**Note** Priority is given to settings in the Master, so the setting for the Slave's default connection path is not required.

Use the following method to allocate data from the Configurator.

- 1,2,3...** Double-click the icon of the Master Unit to which I/O will be allocated and open the Edit Device Parameters Window. (From the Maintenance Mode Window, click the right mouse button over the Master Unit icon and select **Parameters** and **Edit**.)



- Click the **General** Tab, select the Analog Slave to be set, and click the **Advanced Setup** Button.

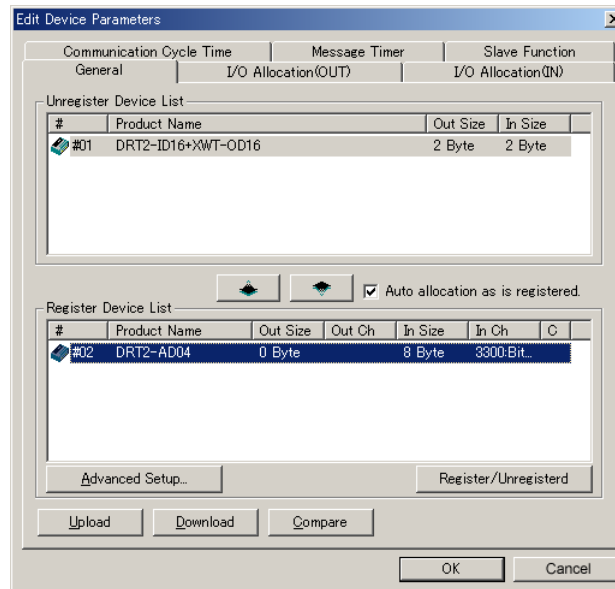

- Click the **Connection** Tab, and select **User Setup**. Select **Use Poll Connection**, and then select the I/O data (pattern) from the pull-down menu for the connection path. In the same way, select **Use Cyclic Connection**, and then select any I/O data (pattern) from the pull-down menu for the connection path.

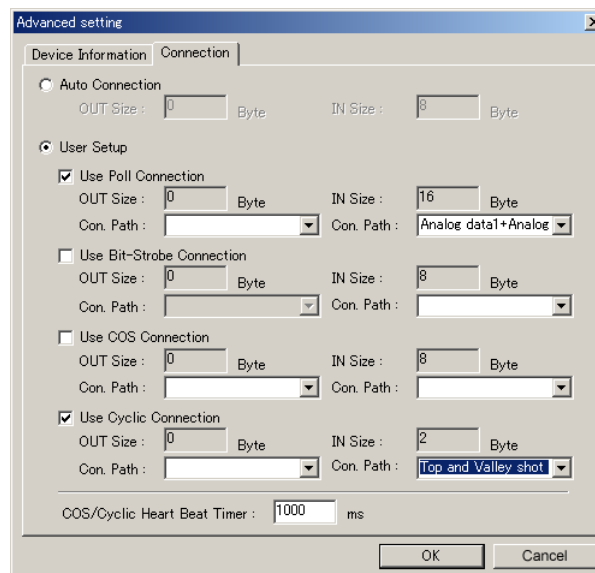

- Click the **OK** Button and exit the window.
- Click the **I/O Allocation (IN)** Tab and edit the I/O allocations. Select the Smart Slave to be set and click the **Edit** Button to display the Edit I/O Allocate Window. Set the *Poll* settings (Analog Data 1 + Analog Data 2 in this example) to block 1, allocated 3300 (word CIO 3300). Set the Cyclic settings (Analog Data 1 + Top/Valley Detection Timing Flags

+ Generic Status Flags in this example) to block 2, allocated 3500 (word CIO 3500).

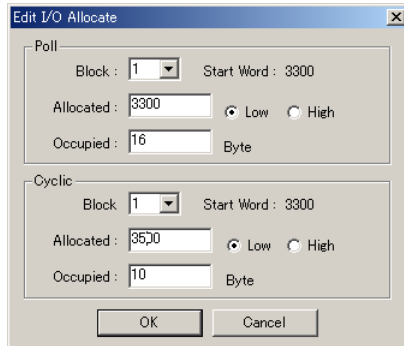

6. Click the **OK** Button and use the following window to confirm that I/O has been allocated correctly.

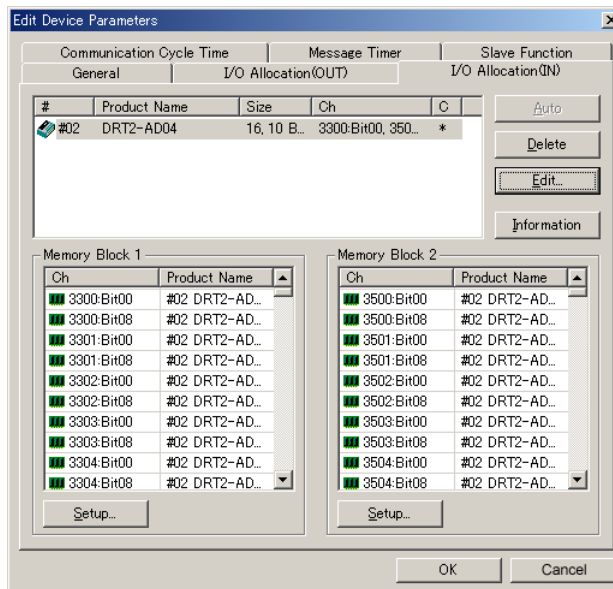

7. Click the **OK** Button, return to the **General** Tab, and click the **Download** Button.

**Note** Do not allocate a COS connection for Analog Data 1 or 2. If a COS connection is allocated for analog data, a frame will be transmitted to the host at every count change. Analog data changes frequently, causing frames to be sent frequently, increasing network traffic. This will increase the communications cycle time.

**I/O Data**

**Analog Data 1 (Instance 104)**

Analog Data 1 is used to monitor analog values. Analog input value is allocated as the default setting, but any one of analog input value, peak value, bottom value, top value, valley value or rate of change can be selected as allocation data.

**Note** The comparator function can be used for the data allocated in Analog Data 1.

The data format used for allocating data in the Master is shown below. Data is allocated as two's complements (8 bytes = 4 words).

15	0
Analog Data 1 for Input 0	
Analog Data 1 for Input 1	
Analog Data 1 for Input 2	
Analog Data 1 for Input 3	

**Analog Data 2 (Instance 114)**

Analog Data 2 is used to monitor other analog data in addition to that in Analog Data 1. Select one type of following data other than that allocated for Analog Data 1: Analog input value, peak value, bottom value, top value, valley value, or rate of change.

**Note** The comparator function cannot be used with Analog Data 2.

The data format used for allocating data in the Master is shown below. Data is allocated as two's complements (8 bytes = 4 words).

15	0
Analog Data 2 for Input 0	
Analog Data 2 for Input 1	
Analog Data 2 for Input 2	
Analog Data 2 for Input 3	

**Generic Status Flags (Instance 121)**

The Generic Status Flags are used to monitor flags that indicate maintenance information (Network Power Voltage Monitor Flag, Unit Conduction Time Monitor Flag, and Analog Cumulative Counter Flag). The following data format is used for allocating flags in the Master (1 byte).

Bit 7	Bit 6	Bit 5	Bit 4	Bit 3	Bit 2	Bit 1	Bit 0
0	0	MRF	CCW	RHW	NPW	0	0

The details of each bit are shown in the following table.

Bit	Abbreviation	Name	Details
0	---	---	Reserved. (Always 0.)
1	---	---	Reserved. (Always 0.)
2	NPW	Network Power Voltage Monitor Flag	Turns ON when the Network power level drops below the set monitor value.
3	RHW	Unit Conduction Time Monitor Flag	Turns ON when the Unit ON time exceeds the set monitor value.
4	CCW	Analog Cumulative Counter Flag	Turns ON when any of the cumulated analog values exceeds the set monitor value.
5	MRF	Unit Error Flag	Turns ON when analog conversion stops due to a Unit error.
6	---	---	Reserved. (Always 0.)
7	---	---	Reserved. (Always 0.)

The following format is used when Generic Status Flags are allocated, starting from the rightmost byte of the Master.

Word 15	8	7	0
+0	Generic Status Flags		

**Top/Valley Detection Timing Flags (Instance 132)**

These flags turn ON for the one-shot time when detecting the top or valley for the top/valley hold function.

These flags are used to time reading the values held as the top and valley values at the Master. The following data format is used when these flags are allocated in the Master (2 bytes).

	Bit 7	Bit 6	Bit 5	Bit 4	Bit 3	Bit 2	Bit 1	Bit 0
+0	0	0	0	0	V_ST3	V_ST2	V_ST1	V_ST0
+1	0	0	0	0	T_ST3	T_ST2	T_ST1	T_ST0

The details of each byte are shown in the following table.

Byte	Abbreviation	Name	Details
+0	V_STx	Valley Detection Timing Flag	Turns ON when a valley is detected by the valley hold function and then turns OFF after the one-shot time has elapsed.
+1	T_STx	Top Detection Timing Flag	Turns ON when a top is detected by the top hold function and then turns OFF after the one-shot time has elapsed.

**Note** The one-shot time can be changed. For details, refer to the one-shot time settings for the top/valley hold function.

The following format is used when the Top/Valley Detection Timing Flags are allocated, starting from the rightmost byte of the Master

Word	15	12 11	8 7	4 3	0
+0		Top Detection Timing Flag		Valley Detection Timing Flag	

**Analog Status Flags (Instance 134)**

The Analog Status Flags include allocations for the Comparator Result Flag, the Top/Valley Detection Timing Flags, and the Off-wire Detection Flags. These flags are used for detection and monitoring.

The data format used for each byte when these flags are allocated in the Master is shown below (4 bytes).

	Bit 7	Bit 6	Bit 5	Bit 4	Bit 3	Bit 2	Bit 1	Bit 0	
+0	BW0	T_ST0	V_ST0	HH	H	PS0	L	LL	Input 0
+1	BW1	T_ST1	V_ST1	HH	H	PS1	L	LL	Input 1
+2	BW2	T_ST2	V_ST2	HH	H	PS2	L	LL	Input 2
+3	BW3	T_ST3	V_ST3	HH	H	PS3	L	LL	Input 3

The details for each bit are shown in the following table.

Bit	Abbreviation	Name		Details
0	LLx	Comparator result	Low Low Limit Alarm Flag	Turns ON when the value of data allocated in Analog Data 1 drops below the Low Low Limit alarm setting.
1	Lx		Low Limit Alarm Flag	Turns ON when the value of data allocated in Analog Data 1 drops below the Low Limit alarm setting.
2	PSx		Normal Flag (pass signal)	Turns ON when none of the alarms (High High Limit, High Limit, Low Low Limit, and Low Limit) have been output.
3	Hx		High Limit Alarm Flag	Turns ON when the value of data allocated in Analog Data 1 exceeds the High Limit alarm setting.
4	HHx		High High Limit Alarm Flag	Turns ON when the value of data allocated in Analog Data 1 exceeds the High High Limit alarm setting.
5	V_STx	Top/valley detection timing	Valley Detection Timing Flag	Used with the valley hold function. Turns ON when a valley is detected, and turns OFF after the one-shot time has lapsed.
6	T_STx		Top Detection Timing Flag	Used with the top hold function. Turns ON when a top is detected, and turns OFF after the one-shot time has lapsed.
7	BWx	Off-wire Detection Flag		Turns ON when a disconnection is detected.

The following format is used when Analog Status Flags are allocated, starting from the rightmost byte of the Master.

	Word 15	8	7	0
+0	For Input 1		For Input 0	
+1	For Input 3		For Input 2	

**Analog Data 1 + Analog Data 2 (Instance 144)**

This data pattern consists of Analog Data 1 followed by Analog Data 2 and is allocated in the Master using the following data format. Negative data values are given as two's complements (16 bytes = 8 words).

	Word 15	0
+0	Analog Data 1 for Input 0	
+1	Analog Data 1 for Input 1	
+2	Analog Data 1 for Input 2	
+3	Analog Data 1 for Input 3	
+4	Analog Data 2 for Input 0	
+5	Analog Data 2 for Input 1	
+6	Analog Data 2 for Input 2	
+7	Analog Data 2 for Input 3	

**Top/Valley Detection Timing Flags + Generic Status Flags (Instance 151)**

This data pattern consists of the Top/Valley Detection Timing Flags followed by Generic Status Flags and is allocated in the Master using the following data format, shown by byte (3 bytes).

	Bit 7	Bit 6	Bit 5	Bit 4	Bit 3	Bit 2	Bit 1	Bit 0
+0	0	0	0	0	V_ST3	V_ST2	V_ST1	V_ST0
+1	0	0	0	0	T_ST3	T_ST2	T_ST1	T_ST0
+2	0	0	MRF	CCW	RHW	NPW	0	0

The following format is used when this data pattern is allocated, starting from the rightmost byte of the Master.

Word	15	8	7	0
+0	Top Detection Timing Flags			Valley Detection Timing Flags
+1	Generic Status Flags			

**Analog Status Flags + Generic Status Flags (Instance 164)**

This data pattern consists of Analog Status Flags followed by Generic Status Flags and is allocated in the Master using the following data format, shown by byte (5 bytes).

	Bit 7	Bit 6	Bit 5	Bit 4	Bit 3	Bit 2	Bit 1	Bit 0	
+0	BD0	T_ST0	V_ST0	HH	H	PS0	LL	L	Input 0
+1	BD1	T_ST1	V_ST1	HH	H	PS1	LL	L	Input 1
+2	BD2	T_ST2	V_ST2	HH	H	PS2	LL	L	Input 2
+3	BD3	T_ST3	V_ST3	HH	H	PS3	LL	L	Input 3
+4	0	0	MRF	CCW	RHW	NPW	0	0	

The following format is used when this data pattern is allocated, starting from the rightmost byte of the Master.

Word	15	8	7	0
+0	For Input 1			For Input 0
+1	For Input 3			For Input 2
+2	Generic Status Flags			

**Analog Data 1 + Top/Valley Detection Timing Flags (Instance 174)**

This data pattern consists of Analog Data 1 followed by the Top/Valley Detection Timing Flags and is allocated in the Master using the following data format (10 bytes).

	Bit 7	Bit 6	Bit 5	Bit 4	Bit 3	Bit 2	Bit 1	Bit 0
+0	Analog Data 1 for Input 0							
+1	Analog Data 1 for Input 1							
+2	Analog Data 1 for Input 2							
+3	Analog Data 1 for Input 3							
+4	Analog Data 1 for Input 3							
+5	Analog Data 1 for Input 3							
+6	Analog Data 1 for Input 3							
+7	Analog Data 1 for Input 3							
+8	0	0	0	0	V_ST3	V_ST2	V_ST1	V_ST0
+9	0	0	0	0	T_ST3	T_ST2	T_ST1	T_ST0

The following format is used when this data pattern is allocated, starting from the rightmost byte of the Master.

Word	15	8	7	0
+0	Analog Data 1 for Input 0			
+1	Analog Data 1 for Input 1			
+2	Analog Data 1 for Input 2			
+3	Analog Data 1 for Input 3			
+4		Top Detection Timing Flags		Valley Detection Timing Flags

**Analog Data 1 + Top/Valley Detection Timing Flags + Generic Status Flags (Instance 184)**

This data pattern consists of Analog Data 1 followed by the Top/Valley Detection Timing Flags and then the Generic Status Flags and is allocated in the Master using the following data format, shown by byte (11 bytes).

	Bit 7	Bit 6	Bit 5	Bit 4	Bit 3	Bit 2	Bit 1	Bit 0
+0	Analog Data 1 for Input 0							
+1	Analog Data 1 for Input 1							
+2	Analog Data 1 for Input 2							
+3	Analog Data 1 for Input 3							
+4	Analog Data 1 for Input 3							
+5	Analog Data 1 for Input 3							
+6	Analog Data 1 for Input 3							
+7	Analog Data 1 for Input 3							
+8	0	0	0	0	V_ST3	V_ST2	V_ST1	V_ST0
+9	0	0	0	0	T_ST3	T_ST2	T_ST1	T_ST0
+10	0	0	MRF	CCW	RHW	NPW	0	0

The following format is used when this data pattern is allocated starting from the rightmost byte of the Master.

Word	15	8	7	0
+0	Analog Data 1 for Input 0			
+1	Analog Data 1 for Input 1			
+2	Analog Data 1 for Input 2			
+3	Analog Data 1 for Input 3			
+4		Top Detection Timing Flags		Valley Detection Timing Flags
	Generic Status Flags			

**Hold Flags (Output) (Instance 190)**

Hold Flags are used with the peak/bottom hold and top/valley hold functions. The Hold Flags are used to control the hold execution timing from the Master and are allocated in the Master using the following data format (1 byte).

**Note** A delay may occur between when the Master's power is turned ON until notification of the Hold Flag status is sent to the Slave.

	Bit 7	Bit 6	Bit 5	Bit 4	Bit 3	Bit 2	Bit 1	Bit 0
+0					HD3	HD2	HD1	HD0



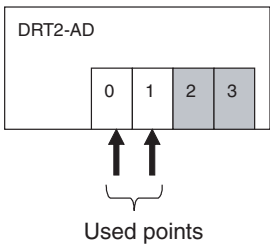
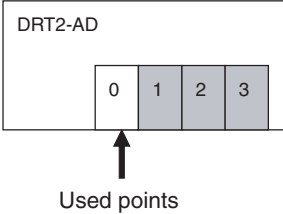

Conversion points	Details
2 points	Converting Inputs 0 and 1.  DRT2-AD 0 1 2 3 ↑ ↑ Used points
1 point	Converting Input 0 only.  DRT2-AD 0 1 2 3 ↑ Used points

**Setting Using the DeviceNet Configurator (DRT2-AD04 Only)**

- 1,2,3...
1. Double-click the icon of the Analog Slave to be set in the Main Window and open the Edit Device Parameters Window. (From the Maintenance Mode Window, click the right mouse button over the Slave icon and select **Parameters** and **Edit**.)
  2. Click the **General** Tab and select the number of conversion points from the pull-down menu under the *Available Channel* field. In the following example, all four points are selected for conversion.

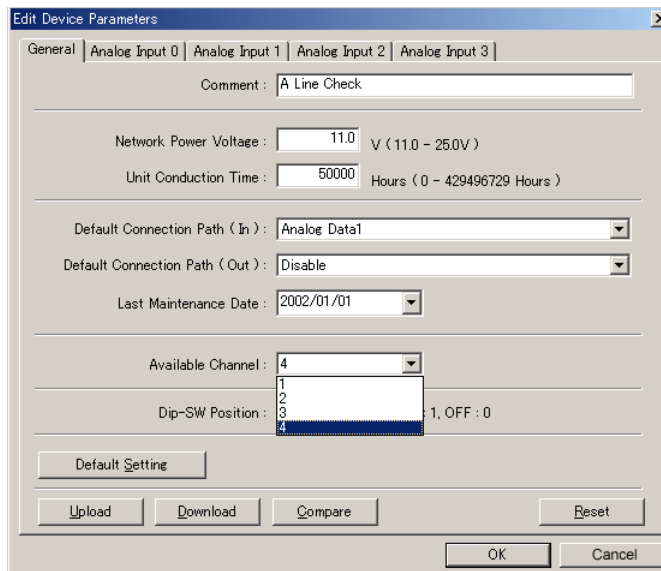

3. Click the **Download** Button, and then click the **Reset** Button to reset the Unit.
4. Click the OK Button and exit the window.

**Moving Average Processing**

This function calculates the average value (moving average) of the previous eight inputs, and uses the resulting value as conversion data. When the input value fluctuates frequently, averaging can be used to produce a stable input value, as shown in the following diagram.

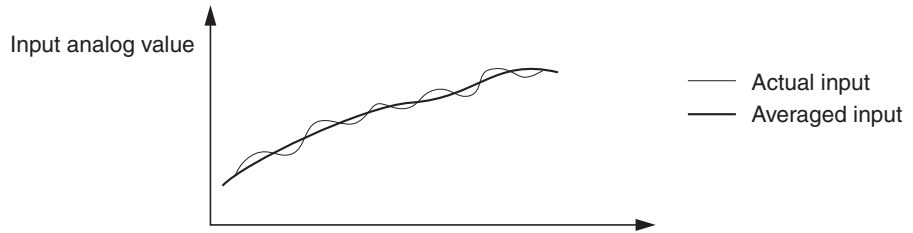

**Setting Using the DeviceNet Configurator**

- 1,2,3... 1. Double-click the icon of the Analog Slave to be set in the Main Window and open the Edit Device Parameters Window. (From the Maintenance Mode Window, click the right mouse button over the Slave icon and select **Parameters** and **Edit**.)
2. Select the Tab Page for the input where moving average processing is to be performed, and select **Moving Average** under the *Function Choice* heading.

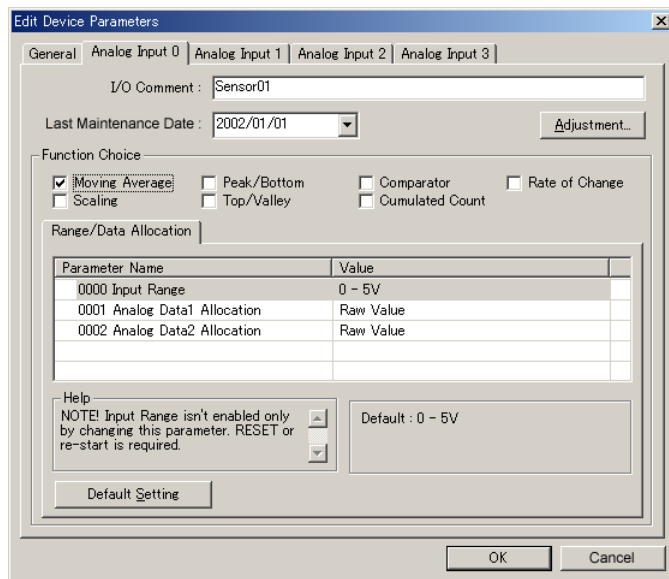

3. Return to the **General** Tab, click the **Download** Button, and then click the **Reset** Button to reset the Unit.
4. Click the **OK** Button and exit the window.

**Scaling**

The default setting is used to perform AD conversion of analog input values, scaling them to a count between 0 and 6,000 (0 to 30,000 in the DRT2-AD04H). Scaling can be used to change scaled values that correspond to the input signal range into other values required by the user (industry unit values). Scaling also eliminates the need for ladder programming in the Master to perform math operations. The following two methods of input scaling can be used.

**Default Scaling**

Analog input values (count values) are converted to the original voltage and current values. The units used are mV or  $\mu\text{A}$ . When default scaling is selected, scaling is performed according to the range used, as shown in the following table.

Input range	0 to 5 V	0 to 10 V	1 to 5 V	-10 to 10 V (AD04 only)	0 to 20 mA	4 to 20 mA
100%	5,000 mV	10,000 mV	5,000 mV	10,000 mV	20,000 $\mu\text{A}$	20,000 $\mu\text{A}$
0%	0000 mV	0000 mV	1,000 mV	-10,000 mV	0000 $\mu\text{A}$	4,000 $\mu\text{A}$
Off-wire	---	---	7FFF hex	---	---	7FFF hex

**User Scaling**

Analog input values (count values) are scaled to user-defined values. The conversion values for 100% and 0% are set using the Configurator.

Input range	0 to 5 V	0 to 10 V	1 to 5 V	-10 to 10 V (AD04 only)	0 to 20 mA	4 to 20 mA
100%	Set using Configurator (-28,000 to 28,000)					
0%	Set using Configurator (-28,000 to 28,000)					
Off-wire	---	---	7FFF hex	---	---	7FFF hex

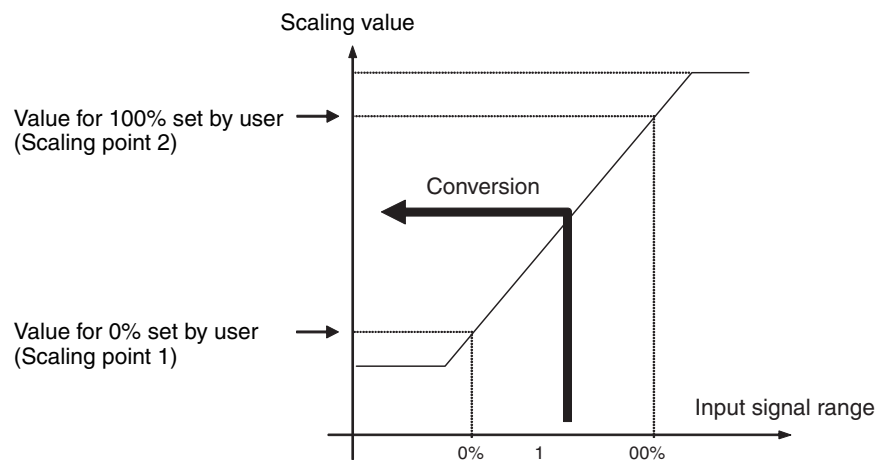

**Note** Reverse scaling, where the 0% scaling value is higher than the 100% scaling value, is also supported.

**Offset Compensation**

Scaling analog input values of linear sensors to distances produces mounting error in the sensor. Offset compensation compensates for error that occurs during scaling. The offset amount is added to the scaled line before processing, as shown in the following diagram. The offset (error) value can be input between -28,000 to 28,000, but make sure that underflow or overflow does not occur. The High Limit is 7FFE hex and the Low Limit is 8000 hex.

**Note** The offset value can be set even when using default scaling.

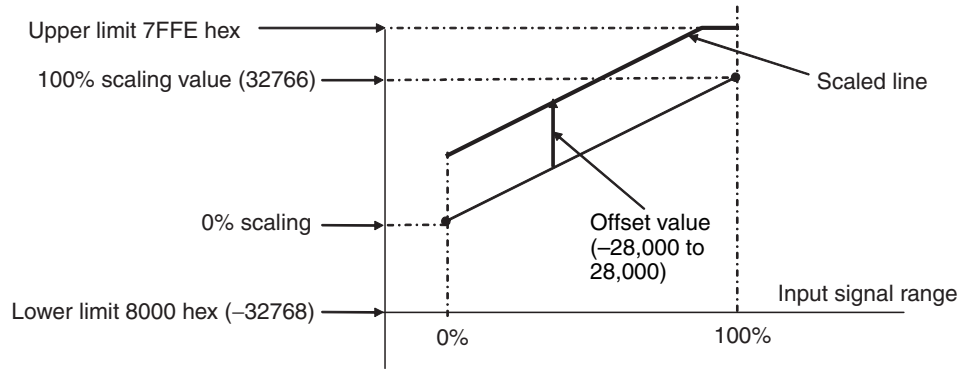

**Setting Using the DeviceNet Configurator**

- 1,2,3...**
1. Double-click the icon of the Analog Slave to be set in the Main Window and open the Edit Device Parameters Window. (From the Maintenance Mode Window, click the right mouse button over the Slave icon and select **Parameters** and **Edit**.)
  2. Select the Tab Page for the input where scaling is to be performed, and select **Scaling** under the *Function Choice* heading.

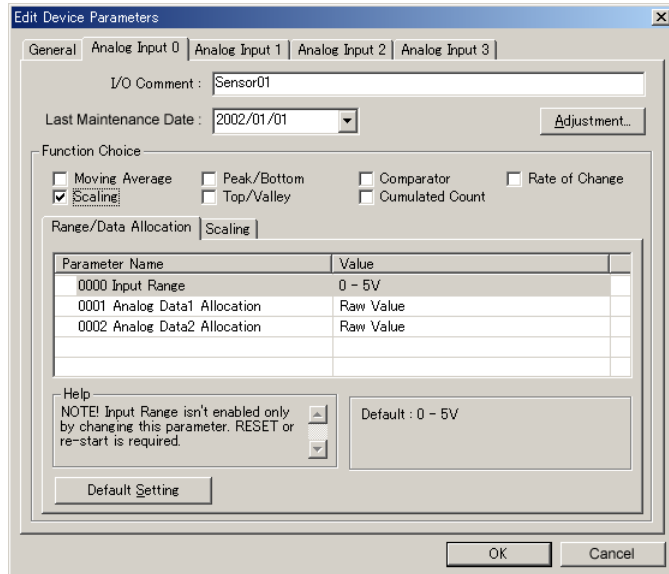

- Click the **Scaling** Tab, and select either **Default Scaling** or **User Scaling**.

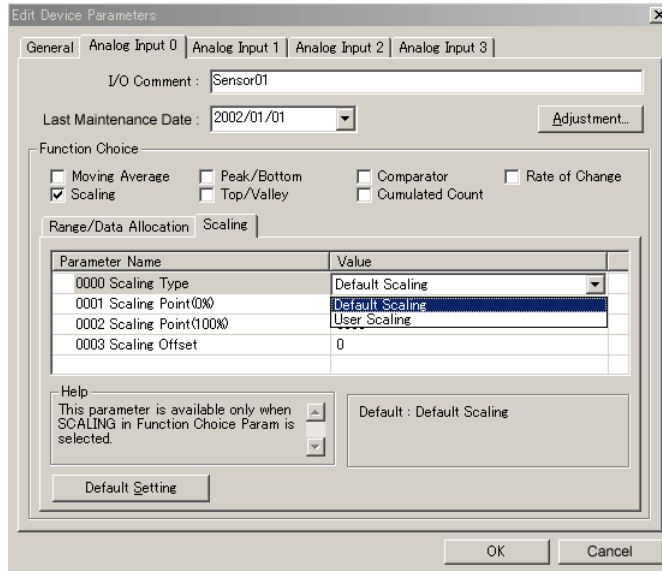

- For user scaling, set the 0% value in the *Scaling point 1* field, and set the 100% value in the *Scaling point 2* field.

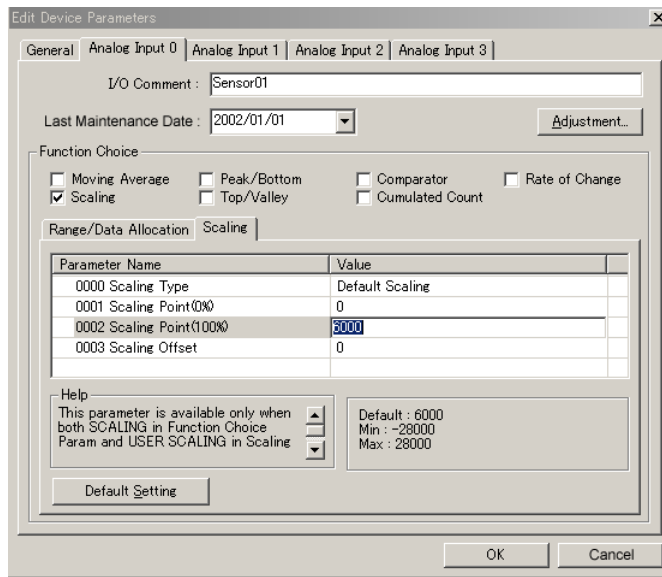

- For offset compensation, set the offset value in the *Scaling Offset* field. Also select either **Default Scaling** or **User Scaling** in the *Scaling Type* field.

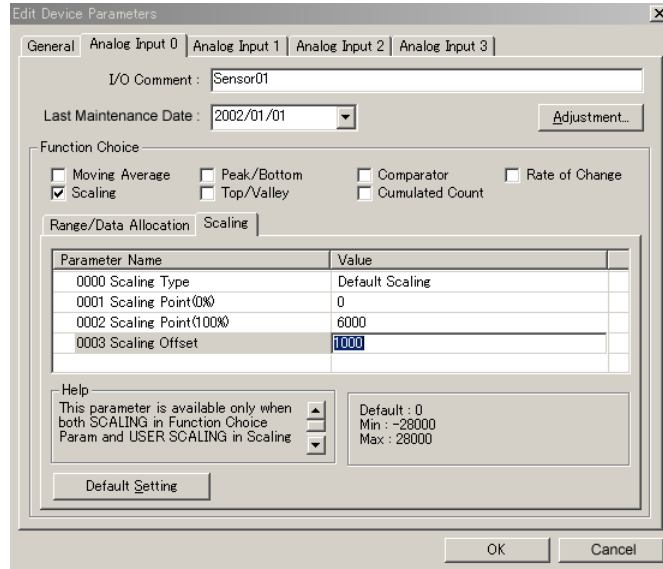

- Return to the **General** Tab, click the **Download** Button, and then click the **Reset** Button to reset the Unit.
- Click the **OK** Button and exit the window.

**Peak/Bottom Hold**

Peak/bottom hold is used to hold the maximum (peak) value or minimum (bottom) value of the analog input value. When the Hold Flag (output) allocated in the OUT Area turns ON, the hold function starts, searching for the peak or bottom value until the Hold Flag turns OFF. (The peak/bottom value is refreshed when the Hold Flag turns OFF.) The comparator function can be used to compare the peak or bottom values allocated as analog data. (Refer to details on the comparator function.)

■ **Example of Bottom Hold**

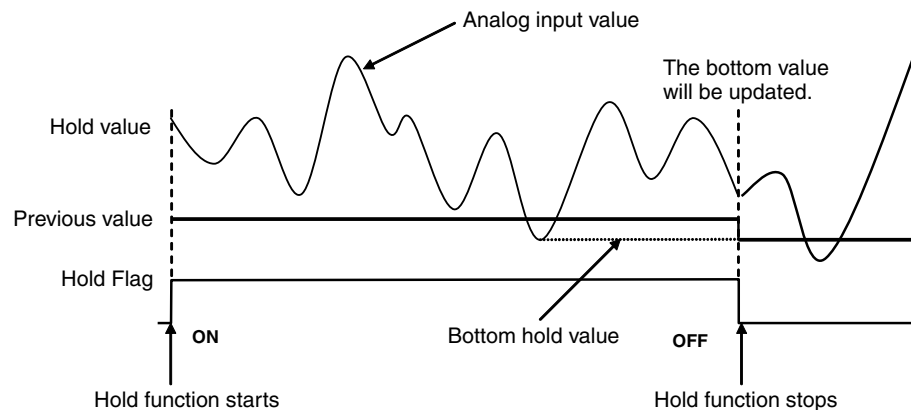

**Note** A delay in network transmission time will occur from the time the Hold Flag turns ON (or OFF) in the Master’s ladder program until notification of the flag’s status is actually sent to the Slave. Therefore, even when the Hold Flag is ON, the first analog data transmitted to the Master when the CPU Unit power is turned ON may be the data from when the Hold Flag was OFF. To collect peak/bottom hold data using the Hold Flag at the Master, configure a ladder

program that considers the transmission delay when the Hold Flag is turned ON, then enables the peak/bottom hold values after a fixed time interval.

### Setting Using the DeviceNet Configurator

- 1,2,3... 1. Double-click the icon of the Analog Slave to be set in the Main Window and open the Edit Device Parameters Window. (From the Maintenance Mode Window, click the right mouse button over the Slave icon and select **Parameters** and **Edit**.)
2. Select the Tab Page for the input where peak/bottom hold is to be set, and select **Peak/Bottom Hold** under the *Function Choice* heading.

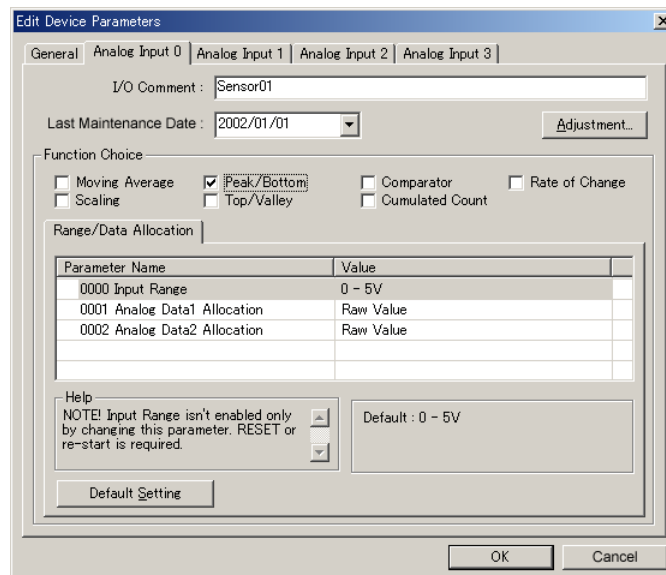

3. To allocate the Hold Flags (output) in the default connection path, click the **General** Tab and select **Holding Value** from the pull-down menu in the *Default Connection Path (Out)* field.

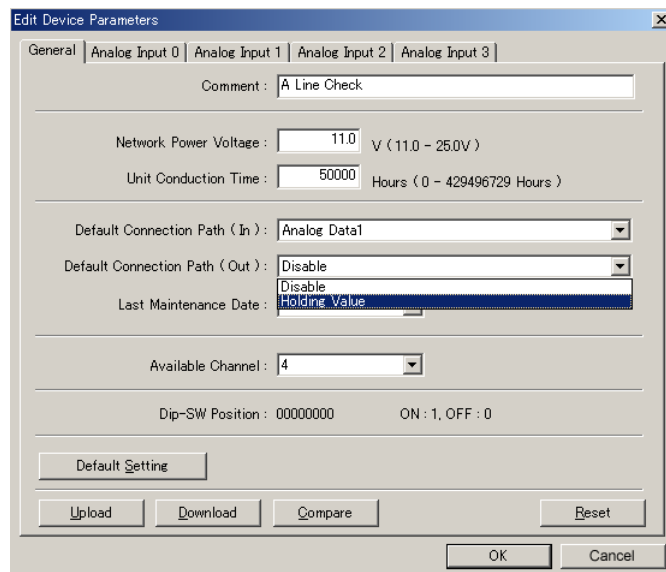

4. Click the **Download** Button and then click the **Reset** Button to reset the Unit.
5. Click the **OK** Button and exit the window.

## Top/Valley Hold

Top/valley hold is used to hold the top and valley values of the analog input value.

Analog values that fluctuate more than twice the hysteresis value are monitored, and the top or valley values are held. The top or valley value is allocated along with the Top/Valley Detection Timing Flags, which can be used to check the hold timing.

When the Hold Flag (output) allocated in the OUT Area turns ON, the hold function starts, refreshing the top or valley value until the Hold Flag turns OFF. (The last value is held when the Hold Flag turns OFF, but the next time the Hold Flag turns ON, the hold value is initialized as soon as a top or valley occurs.) The comparator can be used to compare the top or valley value allocated as analog data. (Refer to details on the comparator function.)

### ■ Example of Valley Hold

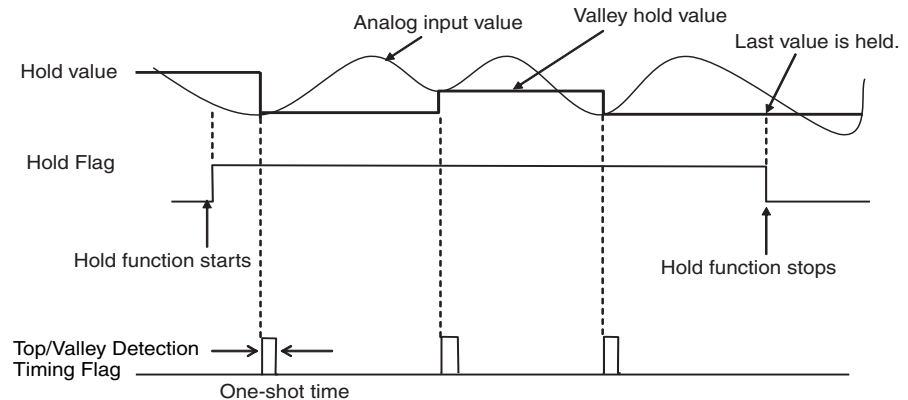

- Note**
1. A delay in network transmission time will occur from the time the Hold Flag turns ON (or OFF) in the Master's ladder program until notification of the flag's status is actually sent to the Slave. Therefore, even when the Hold Flag is ON, the first analog data transmitted to the Master when the CPU Unit power is turned ON may be the data from when the Hold Flag was OFF. To collect top/valley hold data using the Hold Flag at the Master, configure a ladder program which considers the transmission delay time when the Hold Flag is turned ON, then enables the top/valley hold values after a fixed time interval.
  2. The time that the Top/Valley Detection Timing Flags are ON can be adjusted by setting the one-shot time. Use the Configurator to set the one-shot time (the setting range is 1 to 65535 ms).
  3. If the Hold Flag turns OFF during the time the Top/Valley Detection Timing Flag is set to be ON, both flags will turn OFF simultaneously.

### Setting Using the DeviceNet Configurator

- 1,2,3... 1. Double-click the icon of the Analog Slave to be set in the Main Window and open the Edit Device Parameters Window. (From the Maintenance Mode Window, click the right mouse button over the Slave icon and select **Parameters** and **Edit**.)



- Select the Tab Page for the input where top/valley hold is to be set, and select **Top/Valley Hold** under the *Function Choice* heading.

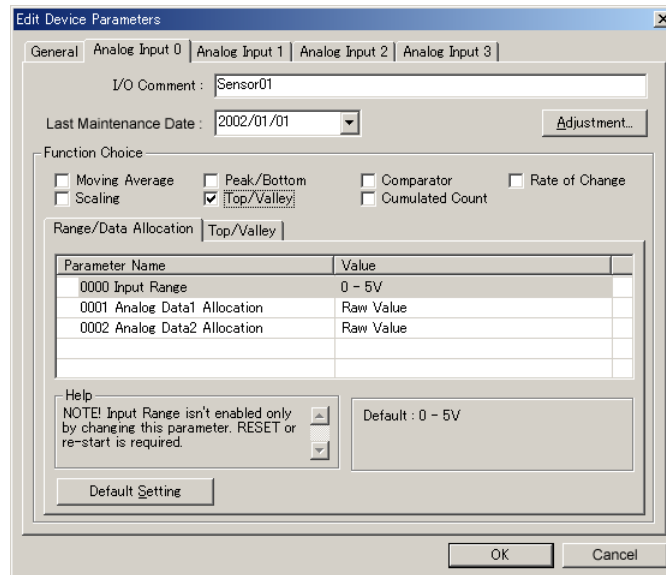

- To allocate the Hold Flag (output) in the default connection path, click the **General** Tab, and select **Holding Value** from the pull-down menu in the *Default Connection Path (Out)* field.

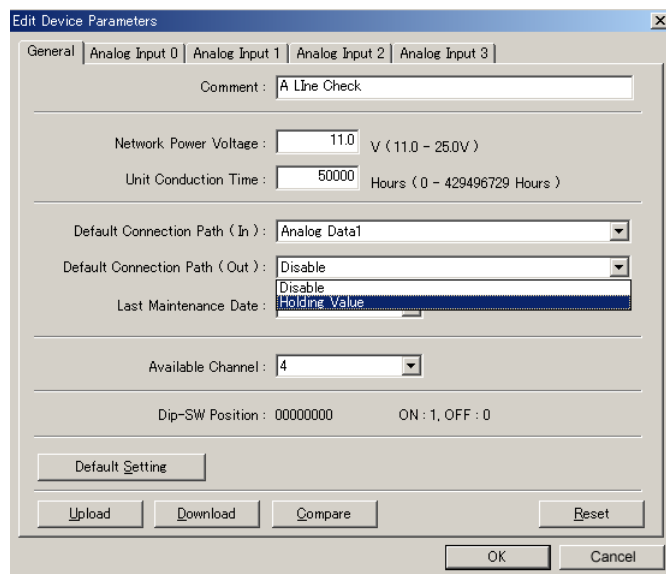

- Click the **Download** Button, and then click the **Reset** Button to reset the Unit.

## Hysteresis Setting

The hysteresis value can be set using the Configurator to prevent detection of top or valley values that occur due to minor fluctuations in the analog input value. This will cause the start of data holding to be delayed after the actual top or valley value occurs, as shown in the following diagram.

■ **Timing for Setting Data**

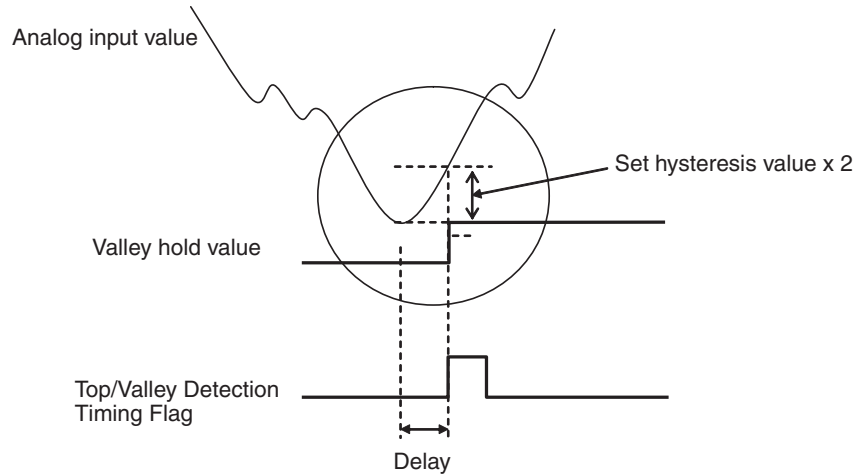

■ **Setting Hysteresis Using the DeviceNet Configurator**

- 1,2,3... 1. Input the value for hysteresis in the *Hysteresis* field in the **Top/Valley** Tab under the *Function Choice* heading.

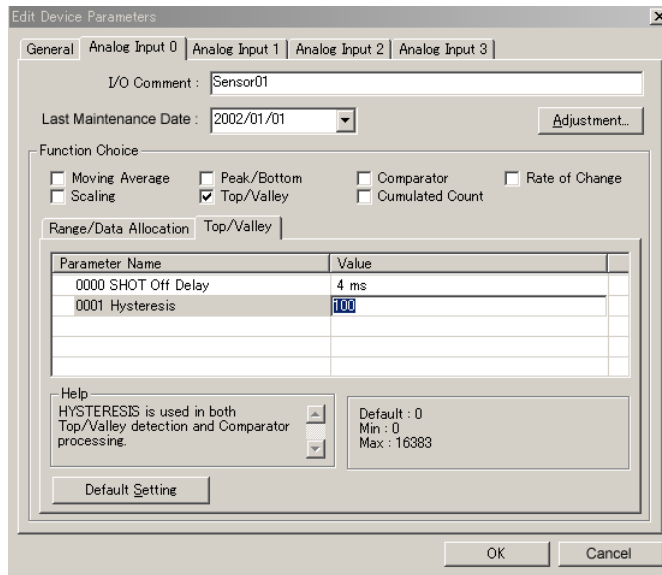

2. Return to the **General** Tab, click the **Download** Button, and then click the **Reset** Button to reset the Unit.  
 3. Click the **OK** Button and exit the window.

**Note** The hysteresis value set for the top/valley hold function is also used by the comparator function.

**One-shot Time Setting**

- 1,2,3... 1. Input the desired value in the *SHOT Off Delay* field of the **Top/Valley** Tab under the *Function Choice* heading.

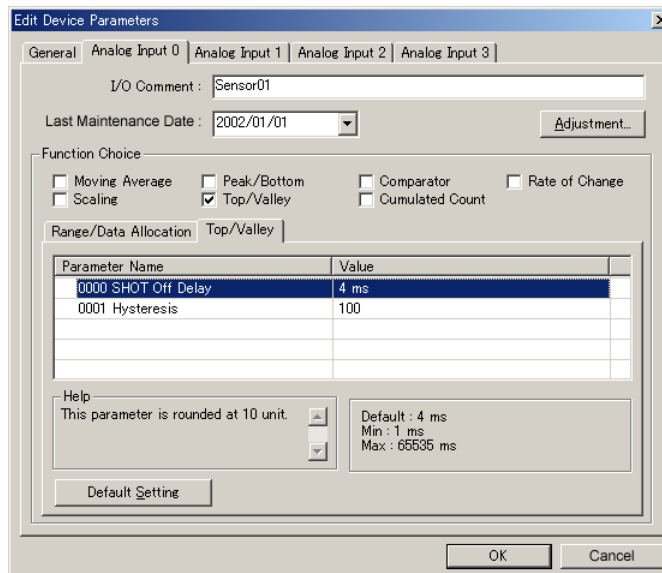

2. Return to the **General** Tab, click the **Download** Button, and then click the **Reset** Button to reset the Unit.  
 3. Click the **OK** Button and exit the window.

**Rate of Change Calculation**

The rate of change can be obtained for each sampling cycle set for the analog input data. This function calculates the difference between each set sampling cycle and value obtained in the previous cycle. The default setting for the sampling cycle is 100 ms and the sampling cycle setting range depends on the model, as shown in the following table.

Model	Sampling cycle setting range
DRT2-AD04	10 to 65,530 ms (Set in 10-ms units.)
DRT2-AD04H	250 to 65,500 ms (Set in 250-ms units.)

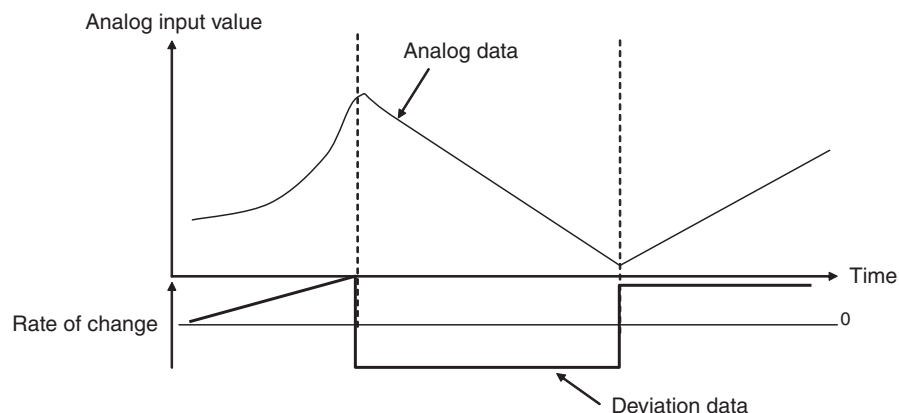

**Note** If the sampling cycle is set to a small value, the rate of change will be sensitive to small changes. If the analog data is subject to minute fluctuations, and the sampling cycle is shorter than the cycle of fluctuation, the fluctuation will be

regarded as the rate of change. To prevent this occurring, use moving average processing, which will set a longer sampling cycle.

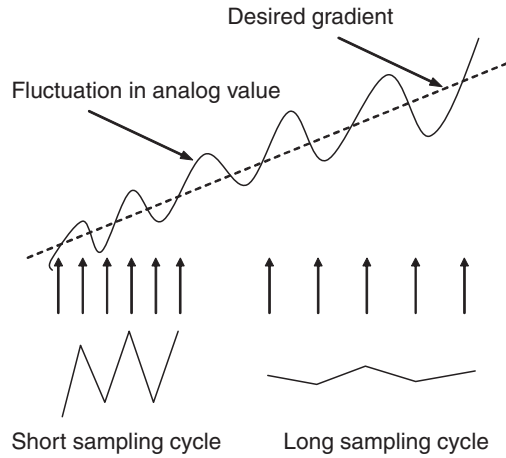

### Setting Using the DeviceNet Configurator

- 1,2,3... 1. Double-click the icon of the Analog Slave to be set in the Main Window and open the Edit Device Parameters Window. (From the Maintenance Mode Window, click the right mouse button over the Slave icon and select **Parameters** and **Edit**.)
2. Select the Tab Page for the input where rate of change is to be set, and select **Rate of Change** under the *Function Choice* heading.

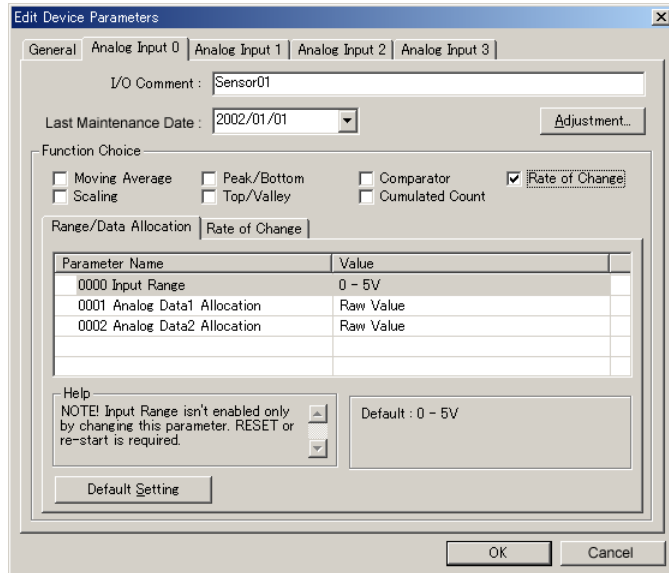

- To set the sampling cycle, click the **Rate of Change** Tab and input the desired value for the sampling cycle in the *Sampling Rate* field.

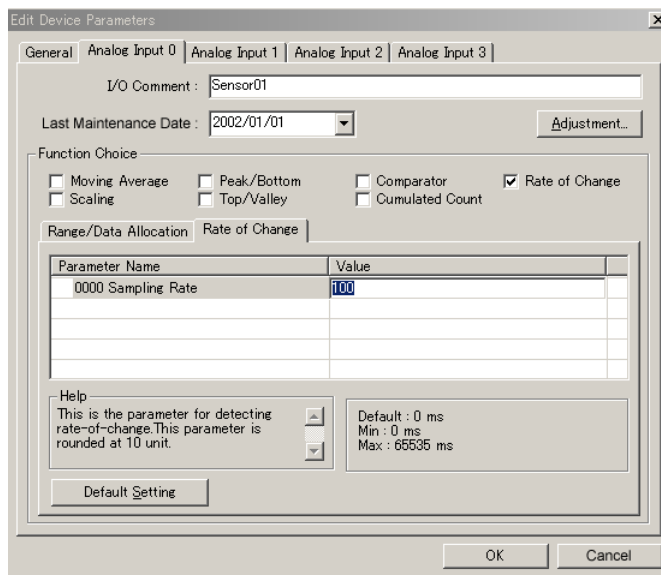

- Return to the **General** Tab, click the **Download** Button, and then click the **Reset** Button to reset the Unit.
- Click the **OK** Button and exit the window.

## Comparator

When the High High Limit, High Limit, Low Low Limit, and Low Limit are set in the Slave, a flag will turn ON when a value exceeds the setting range. The four set values are High High Limit (HH), High Limit (H), Low Low Limit (LL), and Low Limit (L), and the values are compared with those in Analog Data 1. (The comparator function cannot be used with Analog Data 2.) When each of these values is exceeded, the Comparator Result Flag in the area for Analog Status Flags turns ON. If an alarm does not occur, the Normal Flag (pass signal) turns ON.

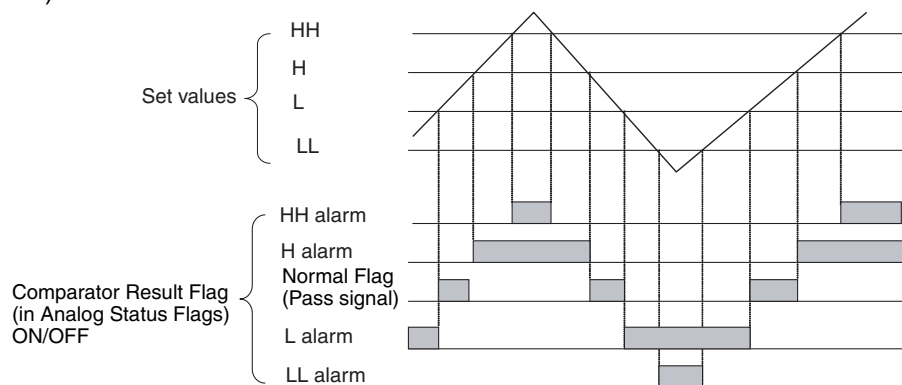

**Note** When the analog input value changes faster than the conversion cycle, the High Limit alarm may turn ON without the Normal Flag (pass signal) turning ON for the Low Limit alarm. Configure ladder programs to prevent this occurring.

**Setting Hysteresis**

The Comparator Result Flag turns OFF when the value is lower than the hysteresis width (H or HH alarm occurs) or exceeds it (L or LL alarm occurs), as shown in the following diagram. If the analog value fluctuates around the threshold, and the flag repeatedly turns ON or OFF, setting hysteresis will stabilize the flag operation.

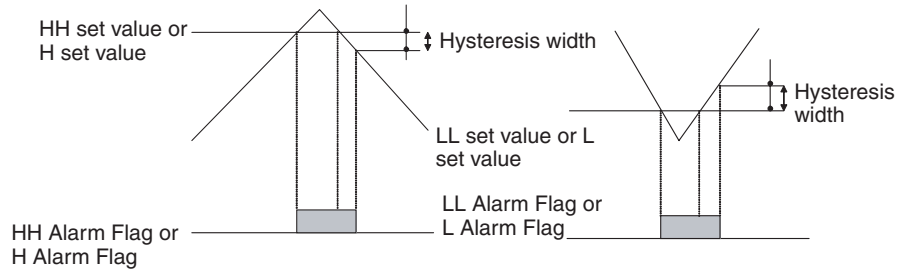

**OFF Delay**

The time until the Comparator Result Flag turns OFF can be extended. For example, even if the Flag is ON momentarily, the OFF delay can be set so that the Master can receive notification of the Flag's status.

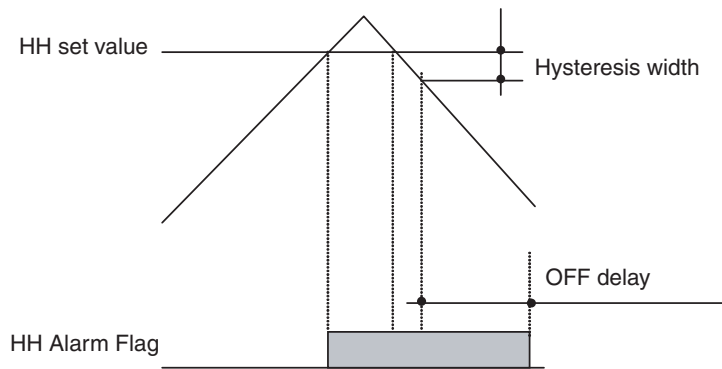

**Setting Using the DeviceNet Configurator**

- 1,2,3... 1. Double-click the icon of the Analog Slave to be set in the Main Window and open the Edit Device Parameters Window. (From the Maintenance Mode Window, click the right mouse button over the Slave icon and select **Parameters** and **Edit**.)

- Select the Tab Page for the input where the comparator function is to be set, and select **Comparator** under the *Function Choice* heading.

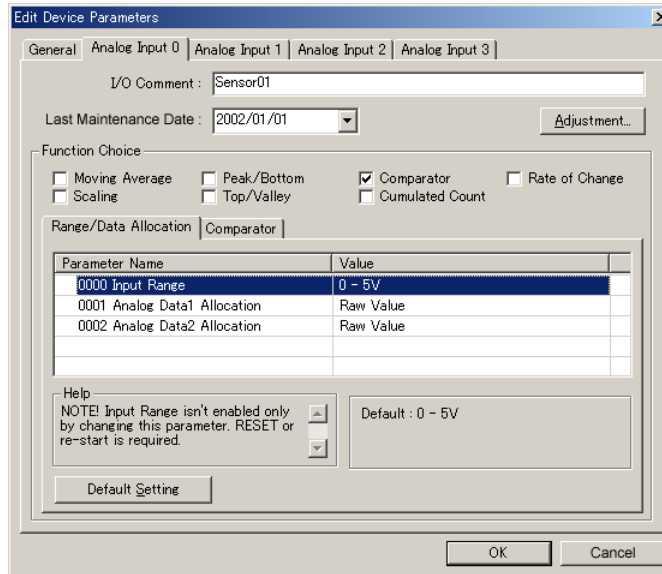

- Click the **Comparator** Tab and set each of the alarm values. The example here shows the setting for *Alarm Trip Point High* (HH limit set value).

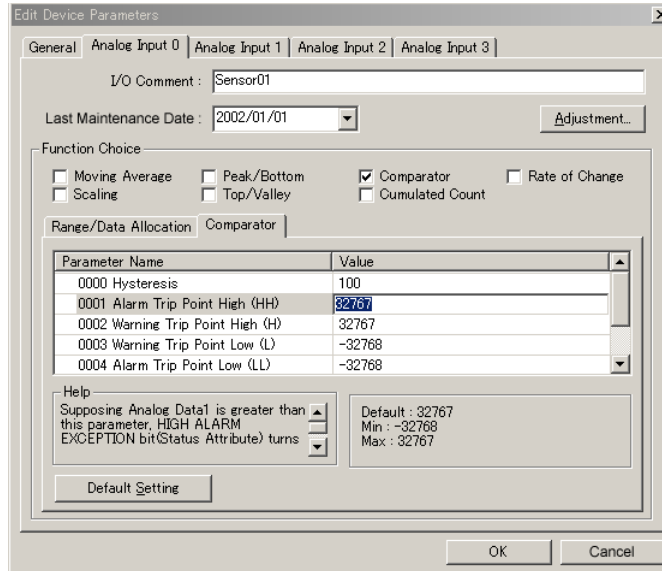

- To set the hysteresis value, input the desired value in the *Hysteresis* field.

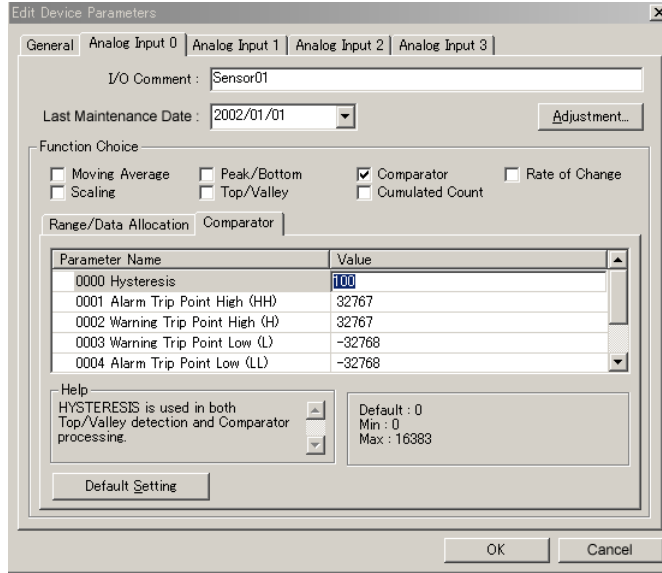

**Note** The hysteresis value set for the comparator function is also used by the top/valley hold function.

- To set the OFF delay function, input the desired value in the *Comparator Off Delay* field.

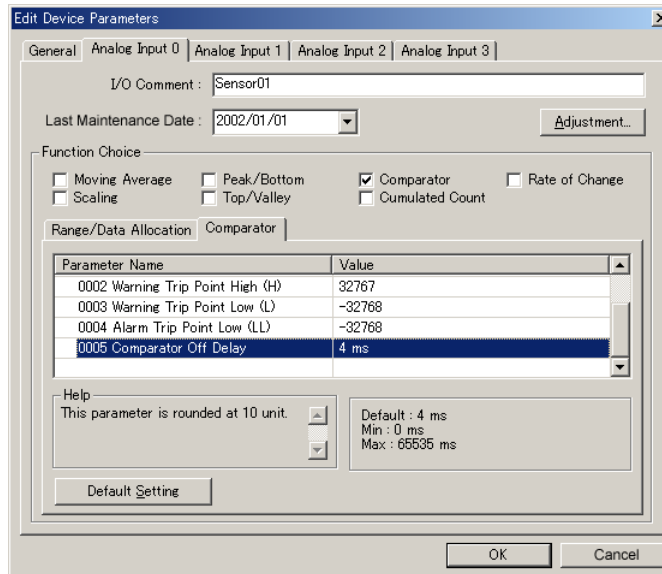

- Return to the **General** Tab, click the **Download** Button, and then click the **Reset** Button to reset the Unit.
- Click the **OK** Button and exit the window.

**Off-wire Detection**

When a disconnection occurs in an analog input line (voltage input or current input), the Off-wire Detection Flag turns ON for each input that is enabled in the number of AD conversion points. The Off-wire Detection Flags are included in the Analog Status Flags.

When Off-wire Detection is enabled, the value of AD conversion data is set to 7FFF hex. When the input returns to a value within the range that can be converted, the Off-wire Detection function will automatically be turned OFF, and normal data conversion will occur.



Off-wire Detection functions with input ranges of 1 to 5 V or 4 to 20 mA only. With the 1 to 5 V input range, an off-wire condition is detected when the input voltage is below 0.76 V (less than 6%). With the 4 to 20 mA input range, an off-wire condition is detected when the input current is below 3.04 mA.

### User Adjustment

Depending on factors such as the characteristics and connection methods of the input device, the input can be adjusted to compensate for error in the input voltage or current. The following diagram shows when compensation is applied to the conversion line at the two points for 0% and 100%.

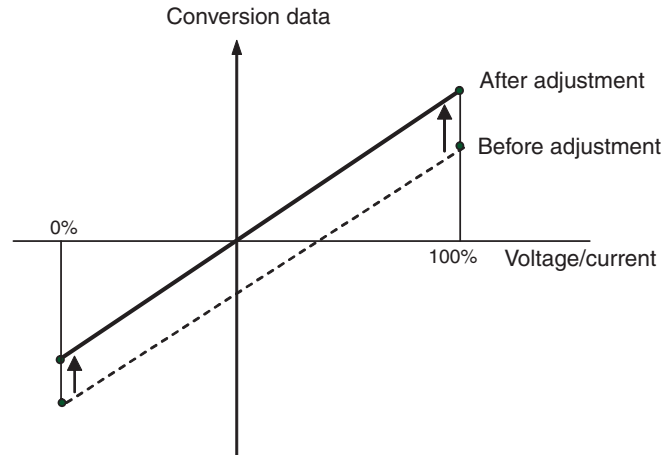

The following table shows the input ranges that support user adjustment.

Input range	Low Limit	High Limit
0 to 5 V	-0.25 to 0.25 V	4.75 to 5.25 V
1 to 5 V	0.8 to 1.2 V	4.8 to 5.2 V
0 to 10 V	-0.5 to 0.5 V	9.5 to 10.5 V
-10 to 10 V	-11 to -9.0 V	9.0 to 11 V
4 to 20 mA	3.2 to 4.8 mA	19.2 to 20.8 mA
0 to 20 mA	-1.0 to 1.0 mA	19 to 21 mA

### Setting Using the DeviceNet Configurator

- 1,2,3...**
1. Double-click the icon of the Analog Slave to be set in the Main Window and open the Edit Device Parameters Window. (From the Maintenance Mode Window, click the right mouse button over the Slave icon and select **Parameters** and **Edit**.)

2. Select the Tab Page for the input to be adjusted, and click the **Adjustment** Button. (At the same time set the input range again.)

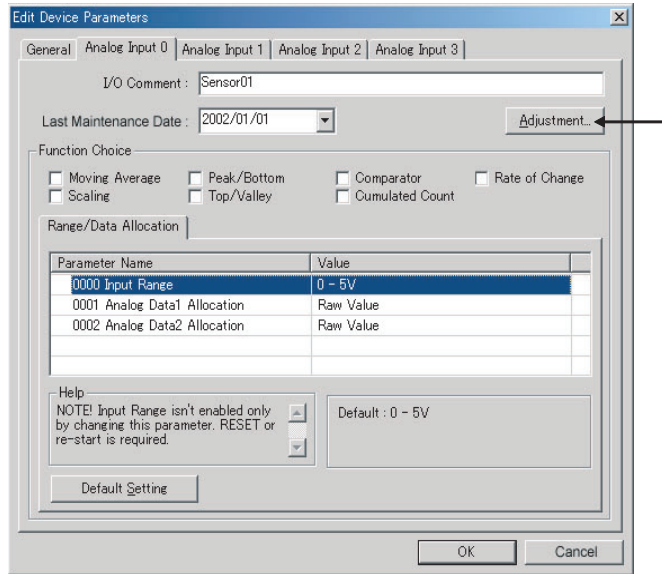

3. Input the voltage (or current) transmitted from the connected device to the Unit's input terminal that is equivalent to the 100% value.
4. Click the **Fix upper adjusting value** Button, and input the adjusted value.

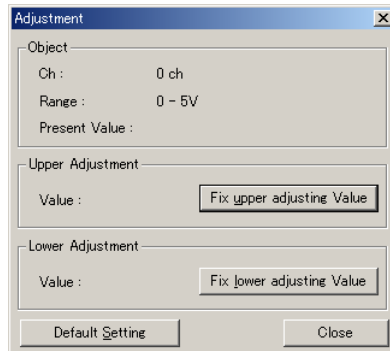

5. Input the voltage (or current) transmitted from the connected device to the Unit's input terminal that is equivalent to the 0% value.
6. Click the **Fix lower adjusting value** Button, and input the adjusted value.

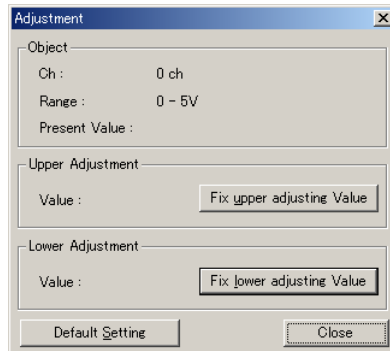

7. To return an adjusted value to the default setting, click the **Default Setting** Button.
8. Close the Adjustment Window, return to the **General** Tab, click the **Download** Button, and then click the **Reset** Button to reset the Unit.

- Click the **OK** Button and exit the window.

## Cumulative Counter

The cumulative counter calculates an approximation to the integral of analog input values over time. The cumulated value can be calculated in “count hours” (by selecting “hours”) or “count minutes” (by selecting “minutes”). The count value is the analog input value in the industry unit obtained after scaling. For example, 100.0 count hours indicates a value equivalent to an analog input value of 100 counts continuing for one hour. The counter range for a four-byte area (two words) for count hours or count minutes is  $-214,748,364.8$  to  $+214,748,364.7$ . Data is displayed on the Configurator in units of 0.1 hour or minute.

Monitor values can also be set in the Unit. When the cumulated count value exceeds the set monitor value, the Cumulative Counter Flag in the area for Generic Status Flags turns ON.

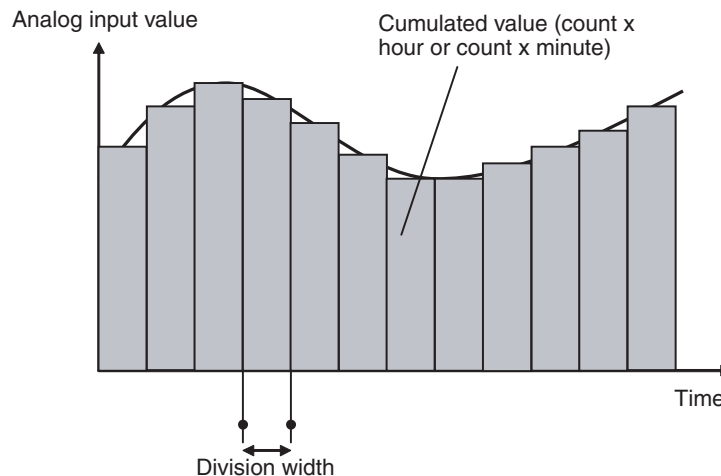

**Note** The following table shows the divisions for the cumulative counter.

### DRT2-AD04

Unit	Divisions
Hour	3.6 s (1/1,000 hour)
Minute	60 ms (1/1,000 minute)

### DRT2-AD04H

Unit	Divisions
Hour	15 s (1/240 hour)
Minute	250 ms (1/240 minute)

## Setting Using the DeviceNet Configurator

- 1,2,3...** Double-click the icon of the Analog Slave to be set in the Main Window and open the Edit Device Parameters Window. (From the Maintenance Mode Window, click the right mouse button over the Slave icon and select **Parameters** and **Edit**.)

- Select the Tab Page for the input where the cumulative counter is to be set, and select **Cumulated Count** under the *Function Choice* heading.

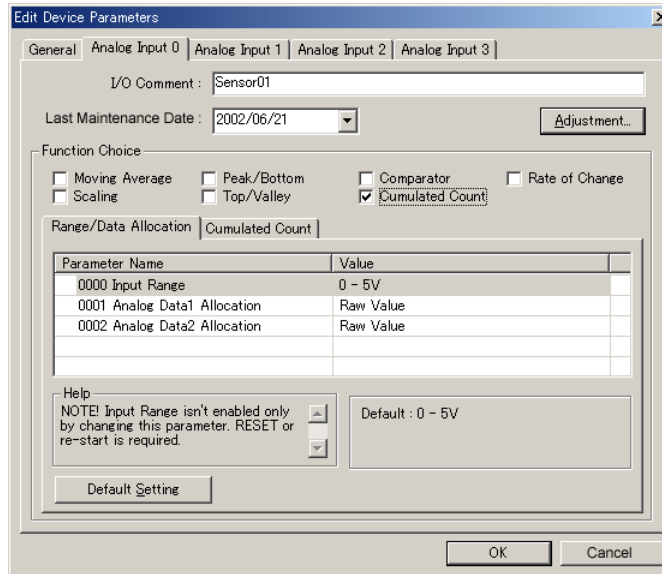

- To set the counter unit, click the **Cumulated Count** Tab and select **Hour** or **Minute** from the pull-down menu in the *Cumulated Timer* field.

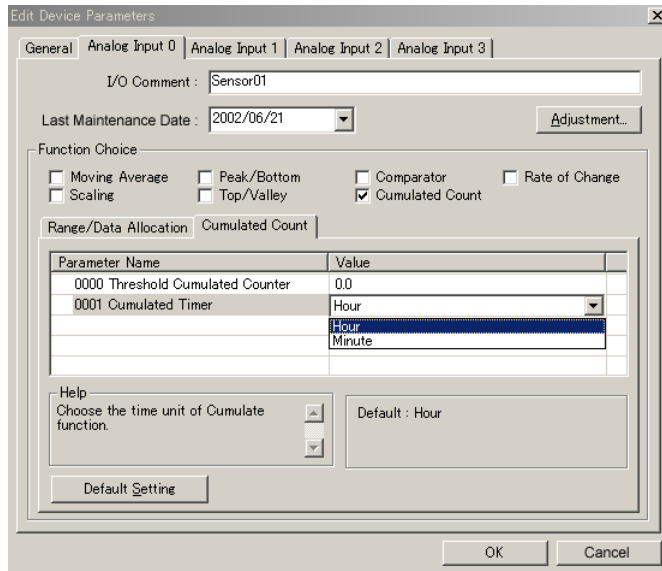

- To set the monitor value, click the **Cumulated Count** Tab, and input the desired value in the *Threshold Cumulated Counter* field.

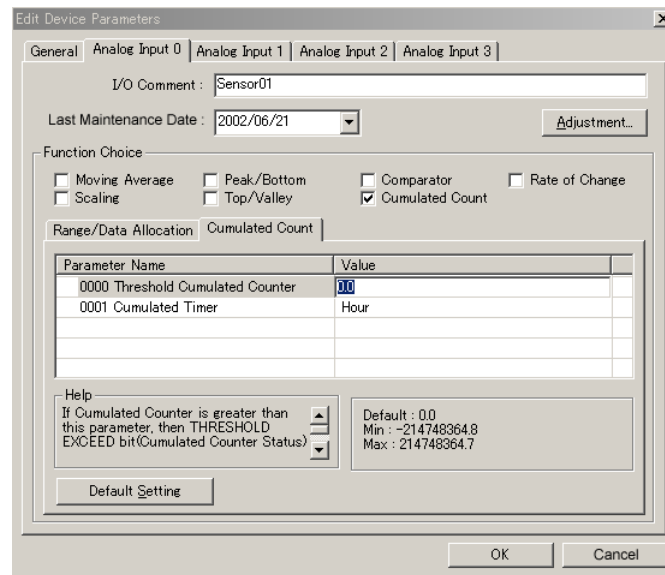

- Return to the **General** Tab, click the **Download** Button, and then click the **Reset** Button to reset the Unit.
- Click the **OK** Button and exit the window.

### Last Maintenance Date

The last maintenance date can be set in the Unit separately for the Unit and the connected devices. It enables the user to easily determine the next maintenance date. The date can be set using the Configurator.

### Setting Using the DeviceNet Configurator

#### ■ Setting the Last Maintenance Date of the Unit

- 1,2,3...** Double-click the icon of the Analog Slave to be set in the Main Window and open the Edit Device Parameters Window. (From the Maintenance Mode Window, click the right mouse button over the Slave icon and select **Parameters** and **Edit**.)

- Click the **General** Tab, and select the applicable date from the pull-down menu in the *Last Maintenance Date* field. (To enter the current date, select **Today**, which is at the bottom of the pull-down menu.)

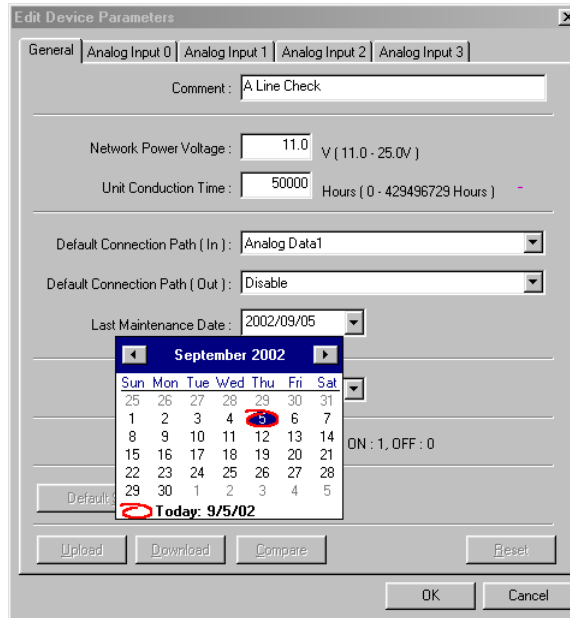

- Click the **Download** Button, and then click the **Reset** Button to reset the Unit.
- Click the **OK** Button and exit the window.

■ **Setting the Last Maintenance Date of the Connected Device**

1,2,3...

- Double-click the icon of the Analog Slave to be set in the Main Window and open the Edit Device Parameters Window. (From the Maintenance Mode Window, click the right mouse button over the Slave icon and select **Parameters** and **Edit**.)
- Click the Tab Page for the input that is connected to a connecting device requiring the last maintenance date to be set. Select the applicable date

from the pull-down menu in the *Last Maintenance Date* field. (To enter the current date, select **Today**, which is at the bottom of the pull-down menu.)

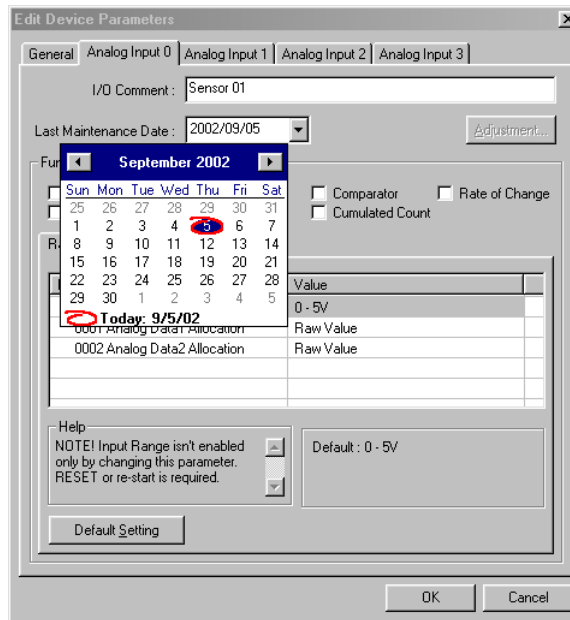

3. Return to the **General** Tab, click the **Download** Button, and then click the **Reset** Button to reset the Unit.
4. Click the **OK** Button and exit the window.

### 7-4-4 Calculating the Conversion Cycle (DRT2-AD04 Only)

The conversion cycle speed can be improved by setting the number of AD conversion points, but will vary with the use of the math operations. Use the following table and formula to calculate the conversion cycle time.

**Formula**

AD conversion cycle time = AD base conversion time +  $\Sigma$  (Additional time for each function)

AD base conversion time: Cycle time when the math operation is not used at all. The value for each conversion point from 1 to 4 is different.

Extra time for each function: The additional time that is required when math operations are used.

The following table shows the AD base conversion times (unit: ms).

Time	1 point	2 points	3 points	4 points
Max	1.66	2.42	3.21	3.82
Min	0.68	0.81	1.47	2.03
Average	0.88	1.60	2.32	3.07

**Note** The DeviceNet communications cycle is 4 ms.

The following table shows the additional time required for each function (unit: ms).

Math operation	Additional time for each point
Moving average	0.045
Scaling	0.055
Peak/bottom hold	0.025
Top/valley hold	0.070
Comparator	0.065

Math operation	Additional time for each point
Rate of change	0.030
Cumulative counter	0.035

**Calculation Example**

When using three points, and applying scaling to the first and second inputs, and the cumulative counter to the third input, the maximum AD conversion cycle time can be obtained by using the following formula.

$$\text{Formula: } 3.21 + (0.055 \times 2) + 0.035 = 3.355 \text{ ms}$$

**Note** With the DRT2-DA04H, the conversion cycle time is within 250 ms even when all of the math operations are being used.

## 7-5 Analog Output Terminals

### 7-5-1 DRT2-DA02 Analog Output Terminal

#### General Specifications

Item	Specifications
Communications power supply voltage	11 to 25 V DC (Supplied from the communications connector.)
Current consumption	120 mA max. (24 V DC)
Noise immunity	Conforms to IEC61000-4-4. 2 kV (power lines)
Vibration resistance	10 to 150 Hz, 0.7-mm double amplitude
Shock resistance	150 m/s <sup>2</sup>
Dielectric strength	500 V AC for 1 min. with 1-mA sensing current (between communications and analog circuits)
Ambient temperature	-10 to +55°C
Ambient humidity	25% to 85% (with no condensation)
Operating environment	No corrosive gases
Storage temperature	-25 to +65°C
Mounting	35-mm DIN Track mounting
Mounting strength	50 N In the direction of the Track: 10 N
Screw tightening torque	M3 (power supply, I/O terminals): 0.5 N·m
Weight	150 g max.

#### Performance Specifications

Item	Specifications	
	Voltage output	Current output
Output points	2 points (outputs 0 and 1)	
Output type	0 to 5 V 1 to 5 V 0 to 10 V -10 to 10 V	0 to 20 mA 4 to 20 mA
Output range setting method	<ul style="list-style-type: none"> <li>DIP switch: Outputs 0 and 1 set separately.</li> <li>Configurator: Outputs 0 and 1 set separately.</li> </ul>	
External output allowable load resistance	1 kΩ min.	600 Ω max.
Resolution	1/6,000 (full scale)	
Overall accuracy	25°C	±0.4% FS
	-10 to 55°C	±0.8% FS
Conversion time	2 ms/ 2 points	



Item	Specifications	
	Voltage output	Current output
DA conversion data	-10 to 10 V range: F448 to 0BB8 hex full scale (-3,000 to 3,000) Other ranges: 0000 to 1770 hex full scale (0 to 6,000) DA conversion range: $\pm 5\%$ FS of the above data ranges.	
Isolation method	Photocoupler isolation (between output and communications lines) No isolation between output signal wires.	
I/O connection method	Terminal-block connection	
Standard accessories	None	

**Names and Functions of Parts**

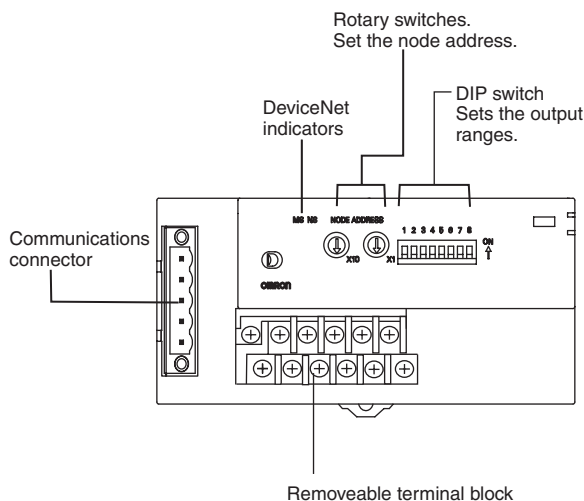

**Setting the Output Signal Range**

**Setting with the DIP Switch**

The output range can be set using the DIP switch or the Configurator.

1 2 3 4 5 6 7 8



Each pin is set according to the following table.

Pin No.	Setting	Specifications
1	Sets output range for Output 0	Default setting: All pins OFF
2		
3		
4	Sets output range for Output 1	Default setting: All pins OFF
5		
6		
7	Sets DA conversion data format	ON: Signed binary OFF: Two's complement
8	Range setting method	OFF: Use Configurator. ON: Use DIP switch. Default setting: OFF

- Note**
1. Always set pin 8 to ON if the DIP switch is used to set the range. If this pin is OFF, the DIP switch settings will not be enabled.
  2. The DIP switch settings are read when the power is turned ON.

Output Range Settings

■ Output 0

Signal range	Pin 1	Pin 2	Pin 3
0 to 5 V	OFF	OFF	OFF
1 to 5 V	ON	OFF	OFF
0 to 10 V	OFF	ON	OFF
-10 to 10 V	ON	ON	OFF
4 to 20 mA	OFF	OFF	ON
0 to 20 mA	ON	OFF	ON

■ Output 1

Signal range	Pin 4	Pin 5	Pin 6
0 to 5 V	OFF	OFF	OFF
1 to 5 V	ON	OFF	OFF
0 to 10 V	OFF	ON	OFF
-10 to 10 V	ON	ON	OFF
4 to 20 mA	OFF	OFF	ON
0 to 20 mA	ON	OFF	ON

Setting Using the DeviceNet Configurator

1,2,3...

Use the following procedure to set the output range for each output using the Configurator.

1. Double-click the icon of the Slave to be set in the Main Window and open the Edit Device Parameters Window. (From the Maintenance Mode Window, click the right mouse button over the Slave icon and select **Parameters** and **Edit**.)
2. Select the Tab Page for the output where the range is to be changed.
3. Click the *Output Range* field, and select the desired range.

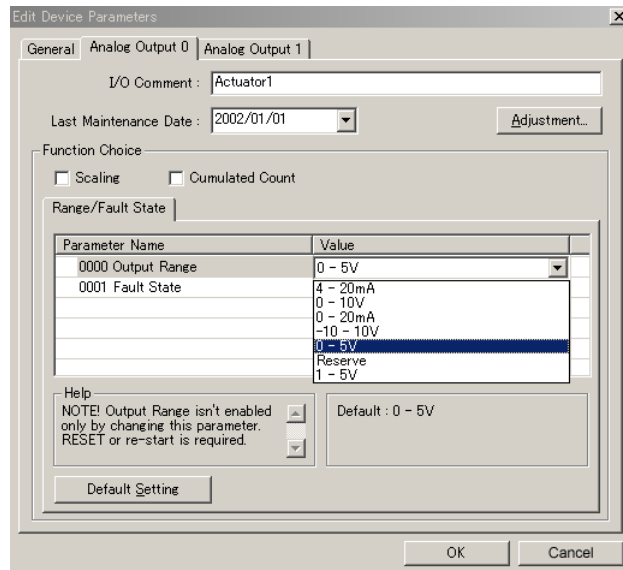

4. Return to the **General** Tab, click the **Download** Button, and then click the **Reset** Button to reset the Unit.
5. Click the **OK** Button and exit the window.

**Internal Circuits**

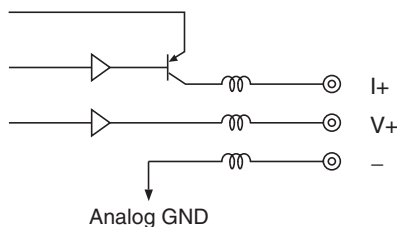

The negative terminals for output 0 and output 1 are connected internally.

**Wiring**

The terminal wiring varies according to whether voltage or current output is used.

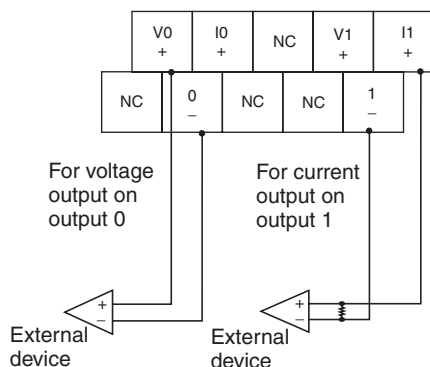

**Note:** The voltage or current output signal ranges are set on the DIP switch or from the Configurator.

**Output Range and Conversion Data**

**Output Range: 0 to 5 V**

The digital values that are output are converted to analog data according to the output range used, as shown below. When the value exceeds the output range, the DA conversion data is fixed at the High Limit or Low Limit set value.

The values 0000 to 1770 hex (0 to 6,000) correspond to the voltage range 0 to 5 V. The output range is -0.25 to 5.25 V.

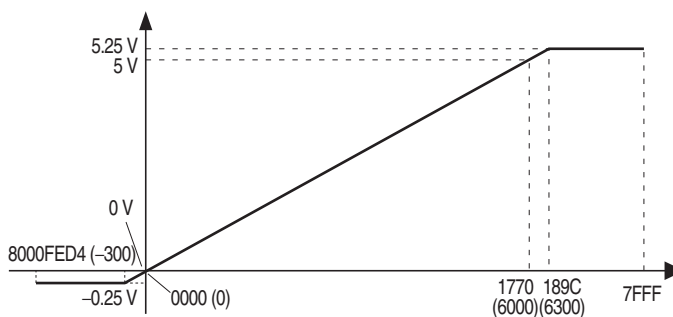

**Output Range: 1 to 5 V**

The values 0000 to 1770 hex (0 to 6,000) correspond to the voltage range 1 to 5 V. The output range is 0.8 to 5.2 V.

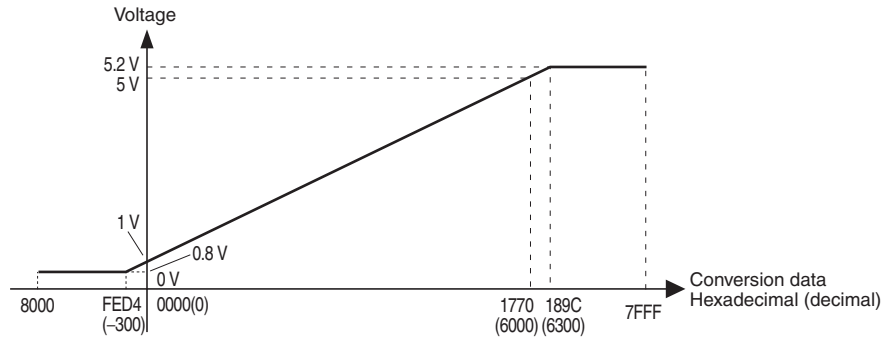

**Output Range: 0 to 10 V**

The values 0000 to 1770 hex (0 to 6,000) correspond to the voltage range 0 to 10 V. The output range is -0.5 to 10.5 V.

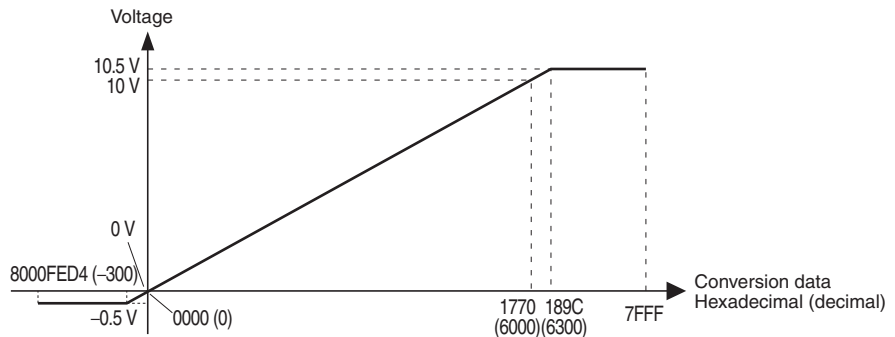

**Output Range: -10 to 10 V**

The values F448 to 0BB8 hex (-3,000 to 3,000) correspond to the voltage range -10 to 10 V. The output range is -11 to 11 V. Negative voltages are specified as two's complements (16 bits).

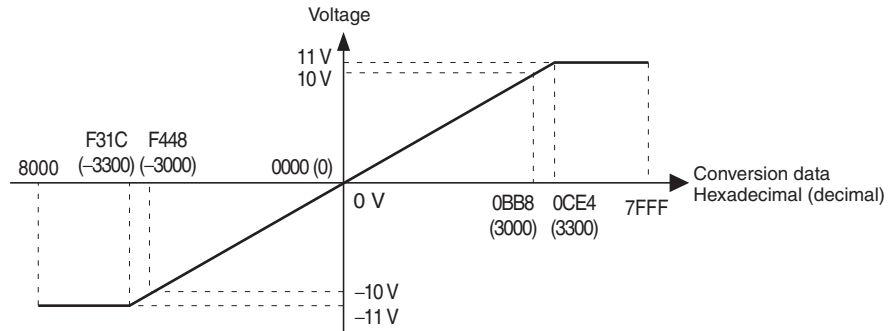

**Output Range: 4 to 20 mA**

The values 0000 to 1770 hex (0 to 6,000) correspond to the current range 4 to 20 mA. The output range is 3.2 to 20.8 mA.

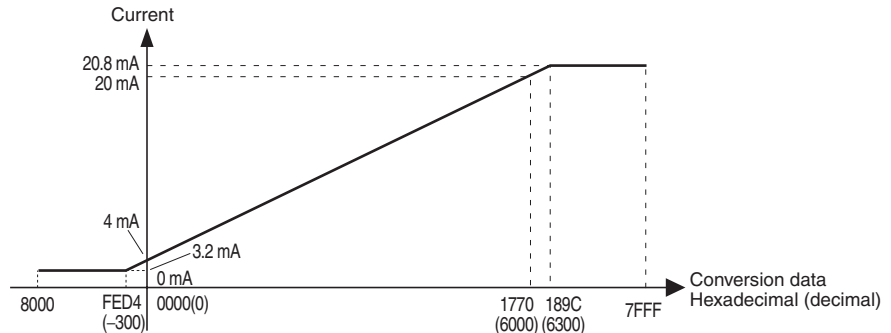

**Output Range: 0 to 20 mA**

The values 0000 to 1770 hex (0 to 6,000) correspond to the current range 0 to 20 mA. The output range is 0 to 21 mA.

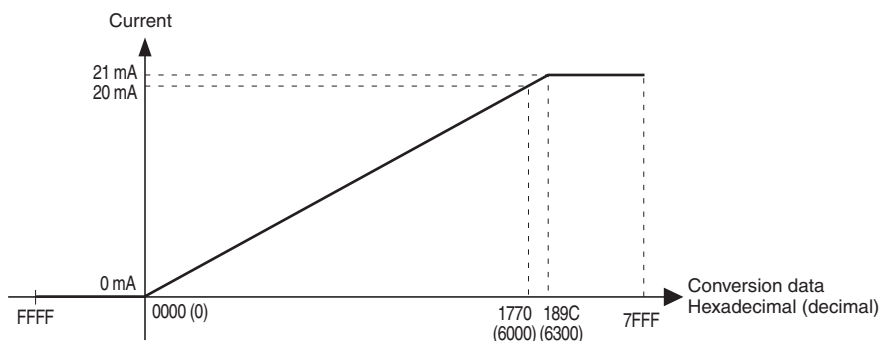

**DA Conversion Data**

DA conversion data is output from the Master as shown in the following diagram.

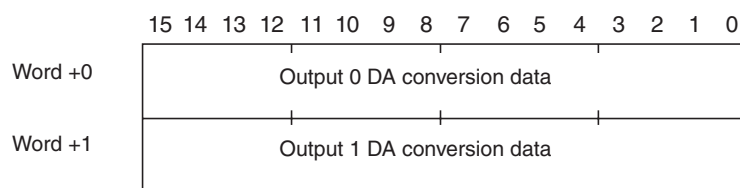

When outputting negative voltages, specify the DA conversion data as two's complements. The NEG instruction can be used to obtain two's complements from absolute values. When pin 7 of the DIP Switch is turned ON, the DA conversion data will be expressed in signed binary.

**Dimensions**

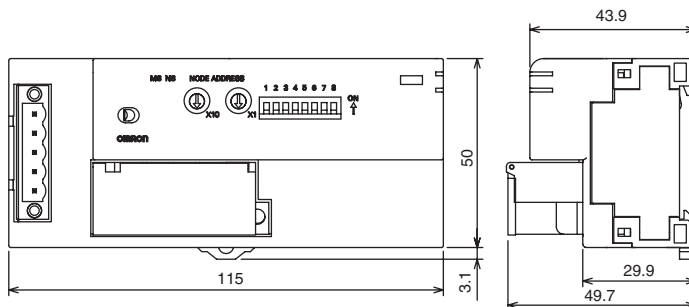

**7-5-2 I/O Data Types and Allocation Methods**

Analog Output Terminals support one type of output data and input data (Generic Status Flags) each. I/O can be allocated in the Master using one of the following three methods.

- 1,2,3...
1. Allocating only analog output values (default I/O data) in the Master.
  2. Allocating selected I/O data.
  3. Allocating user-defined I/O data.

**I/O Data Allocated in the Master**

■ **Allocating Only Analog Output Values (Default I/O Data)**

When using the Analog Output Terminal's default settings, only the analog output values are allocated as I/O in the two words (four bytes) of the Master's OUT Area. The Configurator can also be used to allocate the I/O data in a user-defined address (user allocation).

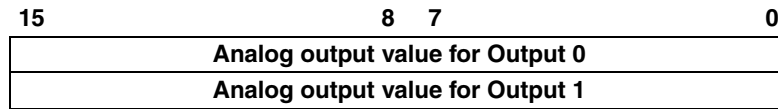

■ **Allocating Selected I/O Data**

Analog data that has been processed using math operations and Status Flags (input) can be allocated in the Master. The Configurator can be used to select the data from a pull-down menu, as shown in the following procedure.

**Setting Using the DeviceNet Configurator**

- 1,2,3...
1. Double-click the icon of the Slave to be set in the Main Window and open the Edit Device Parameters Window. (From the Maintenance Mode Window, click the right mouse button over the Slave icon and select **Parameters** and **Edit**.)
  2. Click the **General** Tab, and select **Analog Data** from the pull-down menu in the *Default Connection Path (Out)* field. To allocate the Status Flags at the same time, select **Generic Status** from the pull-down menu in the *Default Connection Path (In)* field.

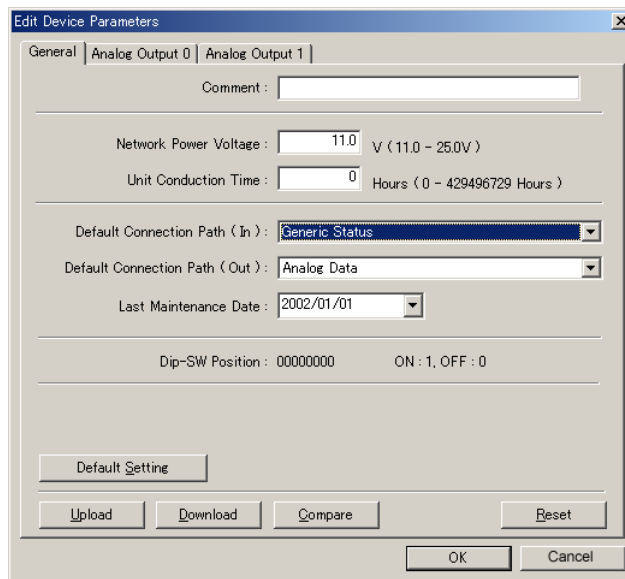

3. Click the **Download** Button, and then click the **Reset** Button to reset the Unit.
4. Click the **OK** Button and exit the window.

■ **Allocating User-defined I/O Data**

Analog data that has been processed using math operations and Status Flags can be selected and allocated as I/O in the Master in any combination. The Configurator can be used to allocate the I/O in the Master. This method is supported by CS/CJ-series DeviceNet Master Units only.

**Note** The settings in the Master are given priority, so the default connection path settings in the Slaves are not required.

### Setting Using the DeviceNet Configurator

- 1,2,3...
1. Double-click the icon of the Slave to be set in the Main Window and open the Edit Device Parameters Window. (From the Maintenance Mode Window, click the right mouse button over the Slave icon and select **Parameters** and **Edit**.)
  2. Click the **General** Tab, select the Analog Slave to be set from the device list, and click the **Advanced Setup** Button.

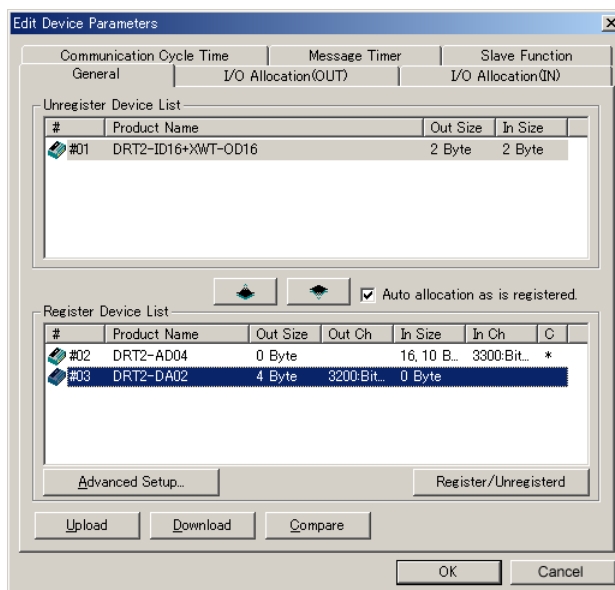

3. Click the **Connection** Tab, and select **User Setup**. Select **Use Poll Connection** and then select **Analog Data** from the pull-down menu in the *Con. Path* field for output. At the same time, select **Use Bit-Strobe Connection**, and then select **Generic Status** from the pull-down menu in the *Con. Path* field for input.

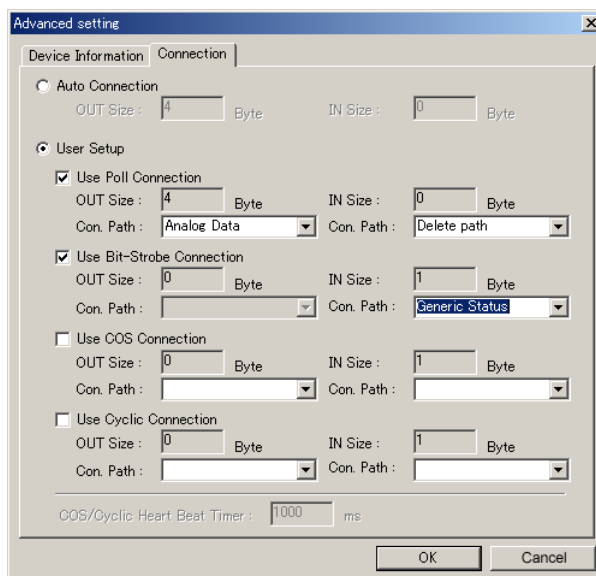

4. Click the **OK** Button.

- Click the **I/O Allocation (IN)** or **I/O Allocation (OUT)** Tab, and edit the I/O allocations. Select the Smart Slave where the I/O allocations are to be edited and click the **Edit** Button to display the Edit I/O Allocate Window. In the following setting example, analog data allocations are set in the **I/O Allocation (OUT)** Tab Page. (In this example, I/O is allocated in block 1, allocated 3202 (word CIO 3202.) Allocate the Status Flags in the same area, setting them on the I/O Allocation (IN) Tab Page.

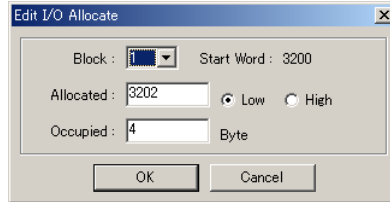

- Click the **OK** Button and use the following window to confirm that I/O has been allocated correctly.

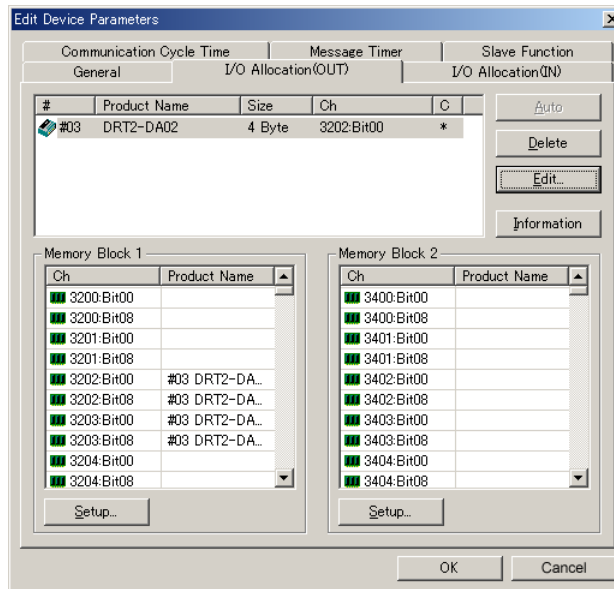

- Return to the **General** Tab, and click the **Download** Button.
- Click the **OK** Button and exit the window.

### I/O Data (Patterns)

#### **Analog Output Data (Instance 192)**

Analog Output Data is used to allocate two words (four bytes) of output data in the Master. The data format used when data in the Master is allocated is shown below. Data is allocated as two's complements.

15	0
<b>Analog output data for Output 0</b>	
<b>Analog output data for Output 1</b>	

#### **Generic Status Flags (Instance 121)**

The Generic Status Flag flags are allocated for monitoring flags with maintenance information (Network Power Voltage Monitor Flag, Unit Conduction Time Monitor Flag, and Analog Cumulative Counter Flag). The following data format is used when these flags are allocated in the Master (1 byte).

<b>Bit 7</b>	<b>Bit 6</b>	<b>Bit 5</b>	<b>Bit 4</b>	<b>Bit 3</b>	<b>Bit 2</b>	<b>Bit 1</b>	<b>Bit 0</b>
0	0	MRF	CCW	RHW	NPW	0	0



The details of each bit are shown in the following table.

Bit	Abbreviation	Name	Details
0	---	---	Reserved. (Always 0.)
1	---	---	Reserved. (Always 0.)
2	<b>NPW</b>	Network Power Voltage Monitor Flag	Turns ON when the Network power level drops below the set monitor value.
3	<b>RHW</b>	Unit Conduction Time Monitor Flag	Turns ON when the Unit ON time exceeds the set monitor value.
4	<b>CCW</b>	Analog Cumulative Counter Flag	Turns ON when any of the cumulated analog values exceeds the set monitor value.
5	<b>MRF</b>	Unit Error Flag	Turns ON when analog conversion stops due to a Unit error.
6	---	---	Reserved. (Always 0.)

The following format is used when the Generic Status Flags are allocated, starting from the rightmost byte of the Master.

Word	15	8	7	0
+1				<b>Generic Status Flags</b>

### 7-5-3 Functions and Setting Methods

#### Scaling

The default setting is used to perform AD conversion, converting analog output values that have been scaled to a count of 0 to 6,000 into corresponding digital values in the output signal range. Scaling can be used to change scaled values that correspond to the output signal range into other values required by the user (industry unit values). Scaling also eliminates the need for ladder programming in the Master to perform math operations. The following two methods of scaling can be used.

#### Default Scaling

Default scaling converts analog output values into voltage or current values. The units used are mV or  $\mu\text{A}$ . When default scaling is selected, scaling is performed according to the output range, as shown in the following table.

Output range	0 to 5 V	0 to 10 V	1 to 5 V	-10 to 10 V	0 to 20 mA	4 to 20 mA
100%	5,000 mV	10,000 mV	5,000 mV	10,000 mV	20,000 $\mu\text{A}$	20,000 $\mu\text{A}$
0%	0000 mV	0000 mV	1,000 mV	-10,000 mV	0000 $\mu\text{A}$	4,000 $\mu\text{A}$
Off-wire	---	---	7FFF hex	---	---	7FFF hex

**User Scaling**

User scaling allows analog output values to be scaled to user-defined values. The conversion values for 100% and 0% are set using the Configurator.

Input range	0 to 5 V	0 to 10 V	1 to 5 V	-10 to 10 V	0 to 20 mA	4 to 20 mA
100%	Set using Configurator (-28,000 to 28,000)					
0%	Set using Configurator (-28,000 to 28,000)					
Off-wire	---	---	7FFF hex	---	---	7FFF hex

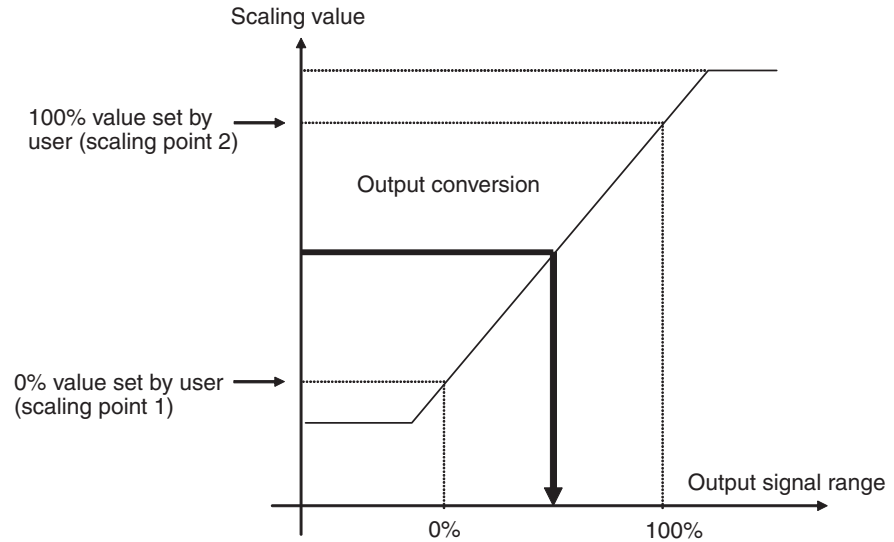

**Note** Reverse scaling, where the 0% scaling value is higher than the 100% scaling value, is also supported.

**Offset Compensation**

Offset compensation is used to compensate for error that occurs during scaling. The offset amount is added to the scaled line before processing, as shown in the following diagram. The offset (error) value can be input between -28,000 and 28,000, but if underflow or overflow occurs in the scaled line, the 100% or 0% output will not be possible. The High Limit is 7FFE hex and the Low Limit is 8000 hex.

**Note** The offset value can be set even when using default scaling.

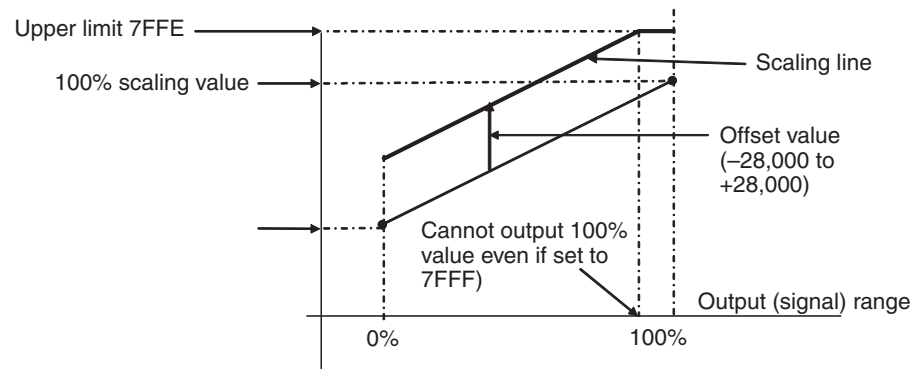

## Setting Using the DeviceNet Configurator

- 1,2,3...
1. Double-click the icon of the Analog Slave to be set in the Main Window and open the Edit Device Parameters Window. (From the Maintenance Mode Window, click the right mouse button over the Slave icon and select **Parameters** and **Edit**.)
  2. Select the Tab Page for the output where scaling is to be performed, and select **Scaling** under the *Function Choice* heading.

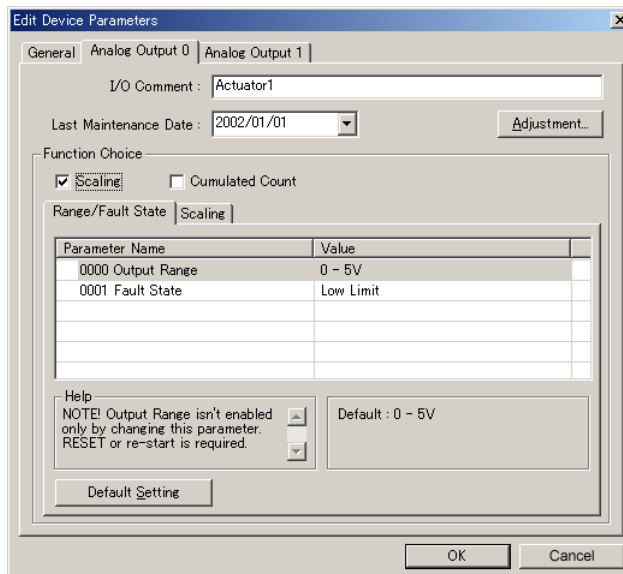

3. To select the scaling type, click the **Scaling** Tab, and select either **Default Scaling** or **User Scaling**. The following example shows when *User Scaling* is selected.

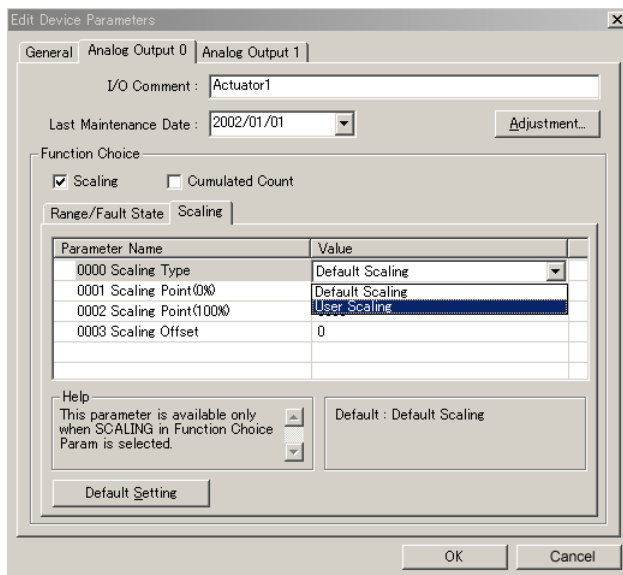

- For user scaling, set the 0% value in the *Scaling point 1* field, and set the 100% value in the *Scaling point 2* field.

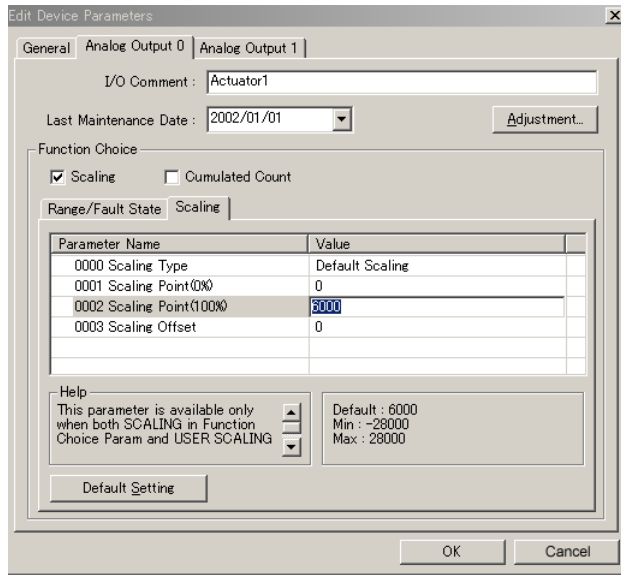

- For offset compensation, set the offset value in the *Scaling Offset* field. Also select either **Default Scaling** or **User Scaling** in the *Scaling Type* field.

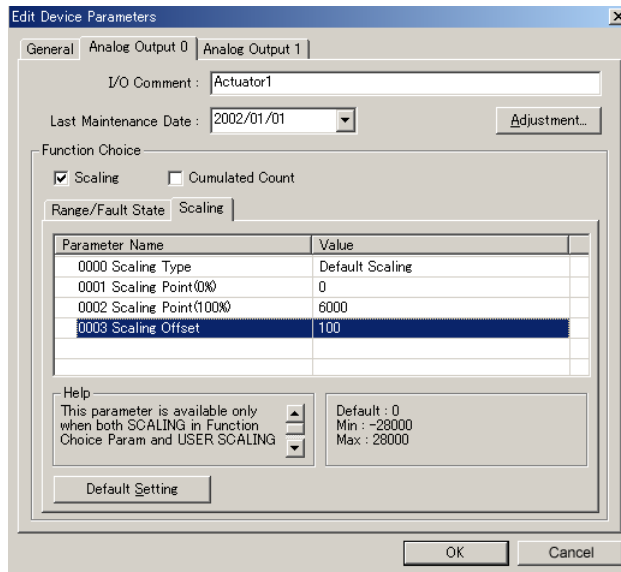

- Return to the **General** Tab, click the **Download** Button, and then click the **Reset** Button to reset the Unit.
- Click the **OK** Button and exit the window.

**User Adjustment**

Depending on factors such as the characteristics and connection methods of the output device, the output can be adjusted to compensate for error in the final output. The following diagram shows when compensation is applied to the conversion line at the two points for 0% and 100%.

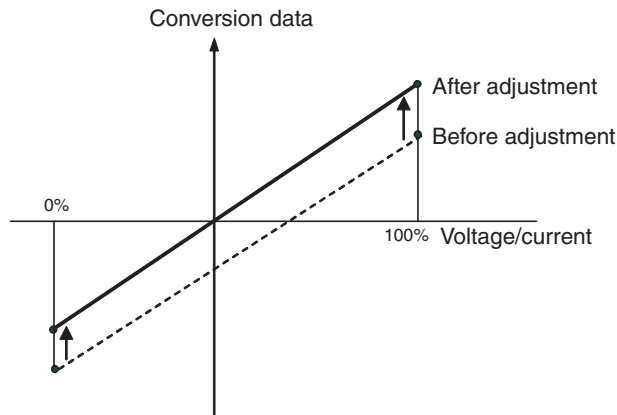

The ranges supported for adjustment (-5% to +5%) are shown in the following table. If adjustment cannot be performed within the following ranges, check the method being used to connect the output device.

Output range	Low Limit	High Limit
0 to 5 V	-0.25 to 0.25 V	4.75 to 5.25 V
1 to 5 V	0.8 to 1.2 V	4.8 to 5.2 V
0 to 10 V	-0.5 to 0.5 V	9.5 to 10.5 V
-10 to 10 V	-11 to -9.0 V	9.0 to 11 V
4 to 20 mA	3.2 to 4.8 mA	19.2 to 20.8 mA
0 to 20 mA	0.2 to 1.0 mA	19 to 21 mA

**Setting Using the DeviceNet Configurator**

- 1,2,3... 1. Double-click the icon of the Analog Slave to be set in the Main Window and open the Edit Device Parameters Window. (From the Maintenance Mode Window, click the right mouse button over the Slave icon and select **Parameters** and **Edit**.)

2. Select the Tab Page for the output to be adjusted, and click the **Adjustment** Button. (At the same time set the output range again.)

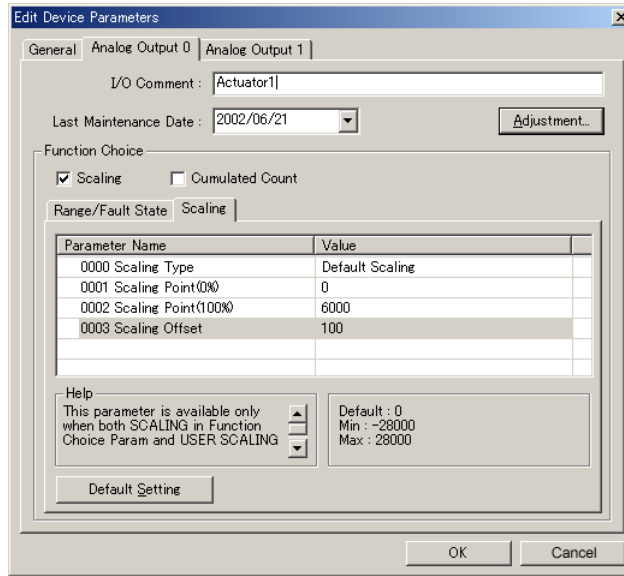

**Adjusting the Low Limit**

3. Output the value that is equivalent to 0% from the Master Unit. Always perform adjustment with the 0% value.
4. Adjust the analog value that is output from the terminal using the Low Limit slide bar, as shown in the following window. Repeat adjustments until the correct 0% value is output from the output device. After compensation is completed, click the **Fix lower adjusting value** Button.

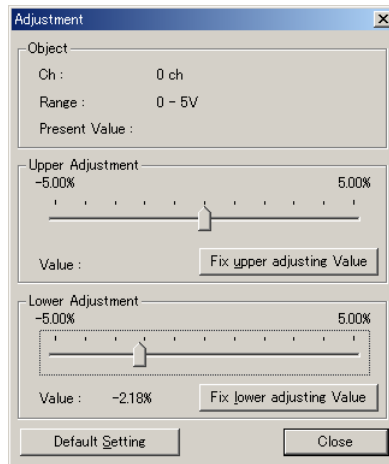

5. To return to the default settings, click the **Default Setting** Button
6. Close the Adjustment Window, return to the **General** Tab, click the **Download** Button, and then click the **Reset** Button to reset the Unit.
7. Click the **OK** Button and exit the window.

**Adjusting the High Limit**

8. Output the value from the Master Unit that is equivalent to the Output Unit's maximum (100%) value. Adjustment is best performed using the 100% value, but can be performed using a lower value.
9. Adjust the analog value that is output from the terminal using the High Limit slide bar, as shown in the following window. Repeat adjustments until the

correct 100% value is output from the output device. After compensation is completed, click the **Fix upper adjusting value** Button.

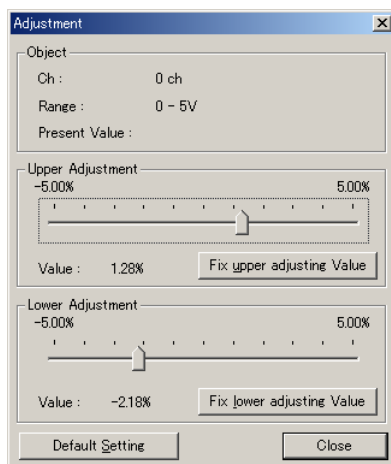

**Note** If the High Limit adjustment is not performed for the 100% value, a discrepancy will occur when the Low Limit is adjusted, so always adjust the Low Limit of Output Terminals before adjusting the High Limit.

### Cumulative Counter

The cumulative counter calculates an approximation to the integral of analog output values over time. The cumulated value can be calculated in “count hours” (by selecting “hours”) or “count minutes” (by selecting “minutes”). The count value is the analog output value in the industry unit obtained after scaling. For example, 100.0 count hours indicates a value equivalent to an analog output value of 100 counts continuing for one hour. The counter range for a four-byte area (two words) for count hours or count minutes is -214,748,364.8 to 214,748,364.7. Data is displayed on the Configurator in units of 0.1 hours or minutes.

Monitor values can also be set in the Unit. When the cumulated count value exceeds the set monitor value, the Cumulative Counter Flag in the area for Generic Status Flags turns ON.

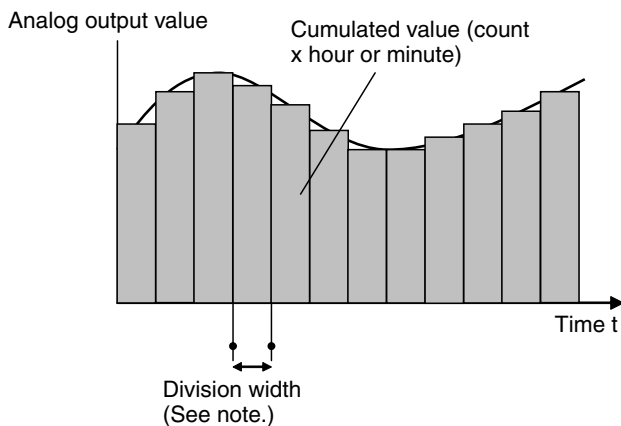

**Note** The following table shows the divisions for the cumulative counter.

Unit	Divisions
Hour	3.6 s (1/1,000 hour)
Minute	60 ms (1/1,000 minute)

Setting Using the DeviceNet Configurator

- 1,2,3...
1. Double-click the icon of the Analog Slave to be set in the Main Window and open the Edit Device Parameters Window. (From the Maintenance Mode Window, click the right mouse button over the Slave icon and select **Parameters** and **Edit**.)
  2. Select the Tab Page for the output where the cumulated counter is to be set, and select **Cumulated Count** under the *Function Choice* heading.

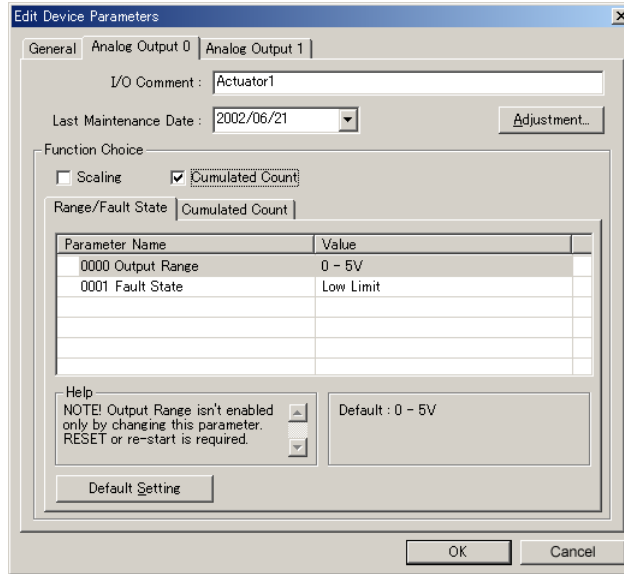

3. To set the counter unit, click the **Cumulated Count** Tab and select **Hour** or **Minute** from the pull-down menu in the *Cumulated Timer* field.

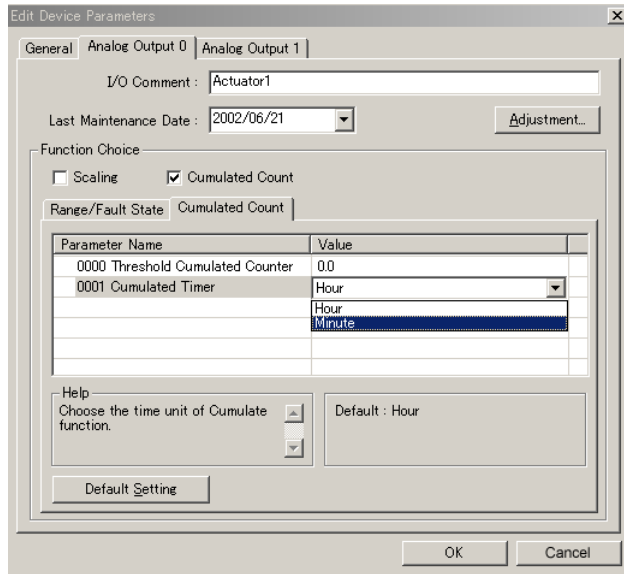



- To set the monitor value, click the **Cumulated Count** Tab, and input the desired value in the *Threshold Cumulated Counter* field.

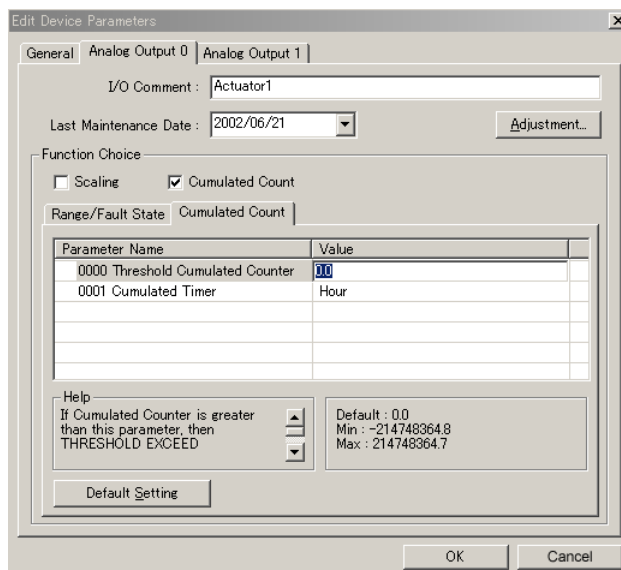

- Return to the **General** Tab, click the **Download** Button, and then click the **Reset** Button to reset the Unit.
- Click the **OK** Button and exit the window.

### Setting Output Value for Errors

The value that is output when communications errors (time-out and BusOff errors) occur can be set for each output. The four output value settings are set using the Configurator.

#### Setting Patterns

Low limit	Outputs the values in the following table according to the output range.
High limit	Outputs the values in the following table according to the output range.
Hold last state	Holds and outputs the value from immediately before the error occurred.
Zero count	Outputs the value when 0 is written from the Host. This setting will be affected by scaling settings that are used.

#### Output Ranges and Values

Output range	Low limit	High limit	Hold last state
0 to 5 V	-0.25 V	5.25 V	Holds value.
1 to 5 V	0.8 V	5.2 V	Holds value.
0 to 10 V	-0.5 V	10.5 V	Holds value.
-10 to 10 V	-11 V	11 V	Holds value.
4 to 20 mA	3.2 mA	20.8 mA	Holds value.
0 to 20 mA	0 mA	21 mA	Holds value.

**Note** When a node address has been used more than once or a Unit error has occurred, the current output will be 0 mA and the voltage output will be 0 V, regardless of the setting.

#### Setting Using the DeviceNet Configurator

- 1,2,3...** Double-click the icon of the Analog Slave to be set in the Main Window and open the Edit Device Parameters Window. (From the Maintenance Mode Window, click the right mouse button over the Slave icon and select **Parameters** and **Edit**.)

2. Select the Tab Page for the output where the error output value is to be set, and select the desired item from the pull-down menu in the *Fault State* field.

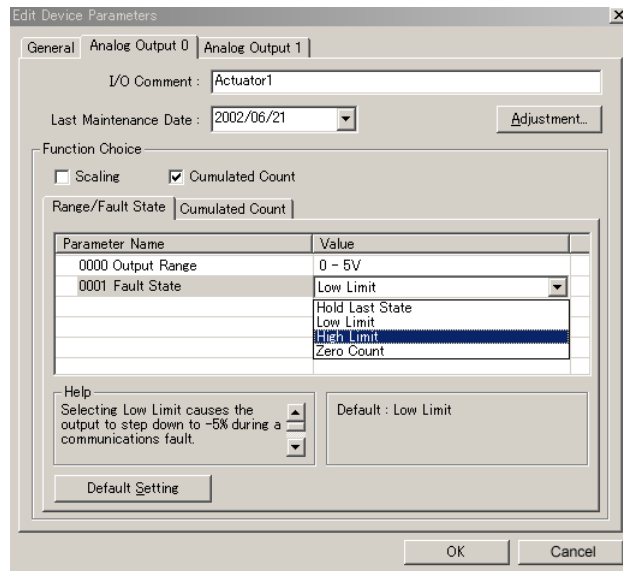

3. Return to the **General** Tab, click the **Download** Button, and then click the **Reset** Button to reset the Unit.
4. Click the **OK** Button and exit the window.]

## 7-6 Temperature Input Terminals

### 7-6-1 DRT2-TS04T and DRT2-TS04P Temperature Input Terminals

#### General Specifications

Item	Specifications	
Model	DRT2-TS04T	DRT2-TS04P
Input type	Thermocouple input	Platinum resistance thermometer input
Number of I/O points	4 inputs (Occupies 4 input words in the Master when normal display mode is selected or 8 input words when 1/100 display mode is selected.)	
Communications power supply voltage	11 to 25 VDC (supplied through communications connector)	
Current consumption	70 mA max. (24 VDC)	
Noise immunity	Conforms to IEC61000-4-4, 2.0 kV	
Vibration resistance	10 to 150 Hz, 0.7 mm double amplitude	
Shock resistance	150 m/s <sup>2</sup>	
Dielectric strength	500 VAC between isolated circuits	
Insulation resistance	20 MΩ min. at 100 V DC (default value)	
Ambient temperature	Operating: -10 to 55°C (with no icing or condensation) Storage: -25 to 65°C	
Ambient operating humidity	25% to 85%	
Atmosphere	Must be free from corrosive gases.	
Mounting method	35-mm DIN track mounting	
Mounting strength	50 N (10 N in the DIN track direction)	
Screw tightening torque	M3: 0.5 N·m	

Item	Specifications	
Terminal strength	Pulling: 50 N	
Weight	160 g max.	160 g max.

**Performance Specifications**

Item	Specifications															
Model	DRT2-TS04T	DRT2-TS04P (See note 1.)														
Input type	Switchable between R, S, K1, K2, J1, J2, T, B, L1, L2, E, U, N, W, and PL2 When set with Configurator: Input types can be set individually for each input. When set with DIP switch: The same input type setting applies to all 4 inputs.	Switchable between PT, JPT, PT2, and JPT2 When set with Configurator: Input types can be set individually for each input. When set with DIP switch: The same input type setting applies to all 4 inputs.														
Indicator accuracy	(±0.3% of indication value or ±1°C, whichever is larger) ±1 digit max. (See note 2.)  <b>Indicator Accuracy in Exceptional Cases</b>	–200 to 850°C input range: (±0.3% of indication value or ±0.8°C, whichever is larger) ±1 digit max. –200 to 200°C input range: (±0.3% of indication value or ±0.5°C, whichever is larger) ±1 digit max.														
	<table border="1"> <thead> <tr> <th>Input type and temperature range</th> <th>Input accuracy</th> </tr> </thead> <tbody> <tr> <td>K1, K2, T, and N below –100°C</td> <td>±2°C ±1 digit max.</td> </tr> <tr> <td>U, L1, and L2</td> <td>±2°C ±1 digit max.</td> </tr> <tr> <td>R and S below 200°C</td> <td>±3°C ±1 digit max.</td> </tr> <tr> <td>B below 400°C</td> <td>Not specified.</td> </tr> <tr> <td>W</td> <td>±0.3% of indication value or ±3°C (whichever is larger) ±1 digit max.</td> </tr> <tr> <td>PL2</td> <td>±0.3% of indication value or ±2°C (whichever is larger) ±1 digit max.</td> </tr> </tbody> </table>	Input type and temperature range	Input accuracy	K1, K2, T, and N below –100°C	±2°C ±1 digit max.	U, L1, and L2	±2°C ±1 digit max.	R and S below 200°C	±3°C ±1 digit max.	B below 400°C	Not specified.	W	±0.3% of indication value or ±3°C (whichever is larger) ±1 digit max.	PL2	±0.3% of indication value or ±2°C (whichever is larger) ±1 digit max.	
Input type and temperature range	Input accuracy															
K1, K2, T, and N below –100°C	±2°C ±1 digit max.															
U, L1, and L2	±2°C ±1 digit max.															
R and S below 200°C	±3°C ±1 digit max.															
B below 400°C	Not specified.															
W	±0.3% of indication value or ±3°C (whichever is larger) ±1 digit max.															
PL2	±0.3% of indication value or ±2°C (whichever is larger) ±1 digit max.															
Conversion cycle	250 ms/4 points															
Temperature conversion data	Hexadecimal data (4-digit hexadecimal when normal display mode is selected or 8-digit hexadecimal when 1/100 display mode is selected.)															
Isolation method	Between input and communication lines: Photocoupler isolation Between temperature input signals: Photocoupler isolation															

- Note**
1. A current of 0.35 mA flows to sensors connected to the DRT2-TS04P.
  2. The indicator accuracy specifications differ depending on the mounting direction. Refer to the above table for details.

**Effects of Mounting Direction on Indicator Accuracy**

In the DRT2-TS04T, a cold junction compensator is included in the Terminal Block. The indicator accuracy will be reduced depending on the mounting direction if just the Terminal Unit itself is replaced and the serial numbers of the Terminal Block and Terminal Unit do not match. The serial numbers of the Terminal Block and Terminal Unit can be found on the labels affixed to the Units as shown below.

**Terminal Unit Label**

Remove the terminal block. The label is attached to the Unit under the terminal block.



**Terminal Block Label**

The label is attached to the back of the terminal block.

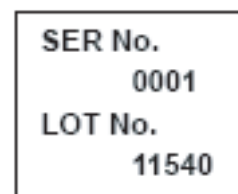

If the serial number of the terminal block and Unit are the same, basic performance specifications apply regardless of the mounting direction. If the serial numbers are different, the following indication accuracies apply.

Mounting direction	Input accuracy														
Mounted normally (1)	As specified in the Performance Specifications.														
Mounted in any other direction other than (1)	$\pm 0.3\%$ of indication value or $\pm 2^{\circ}\text{C}$ (whichever is larger) $\pm 1$ digit max. <b>Indicator Accuracy in Exceptional Cases</b> <table border="1"> <thead> <tr> <th>Input type and temperature range</th> <th>Input accuracy</th> </tr> </thead> <tbody> <tr> <td>K1, K2, T, and N below <math>-100^{\circ}\text{C}</math></td> <td><math>\pm 3^{\circ}\text{C} \pm 1</math> digit max.</td> </tr> <tr> <td>U, L1, and L2</td> <td><math>\pm 3^{\circ}\text{C} \pm 1</math> digit max.</td> </tr> <tr> <td>R and S below <math>200^{\circ}\text{C}</math></td> <td><math>\pm 4^{\circ}\text{C} \pm 1</math> digit max.</td> </tr> <tr> <td>B below <math>400^{\circ}\text{C}</math></td> <td>Not specified.</td> </tr> <tr> <td>W</td> <td><math>\pm 0.3\%</math> of indication value or <math>\pm 4^{\circ}\text{C}</math> (whichever is larger) <math>\pm 1</math> digit max.</td> </tr> <tr> <td>PL2</td> <td><math>\pm 0.3\%</math> of indication value or <math>\pm 3^{\circ}\text{C}</math> (whichever is larger)</td> </tr> </tbody> </table>	Input type and temperature range	Input accuracy	K1, K2, T, and N below $-100^{\circ}\text{C}$	$\pm 3^{\circ}\text{C} \pm 1$ digit max.	U, L1, and L2	$\pm 3^{\circ}\text{C} \pm 1$ digit max.	R and S below $200^{\circ}\text{C}$	$\pm 4^{\circ}\text{C} \pm 1$ digit max.	B below $400^{\circ}\text{C}$	Not specified.	W	$\pm 0.3\%$ of indication value or $\pm 4^{\circ}\text{C}$ (whichever is larger) $\pm 1$ digit max.	PL2	$\pm 0.3\%$ of indication value or $\pm 3^{\circ}\text{C}$ (whichever is larger)
Input type and temperature range	Input accuracy														
K1, K2, T, and N below $-100^{\circ}\text{C}$	$\pm 3^{\circ}\text{C} \pm 1$ digit max.														
U, L1, and L2	$\pm 3^{\circ}\text{C} \pm 1$ digit max.														
R and S below $200^{\circ}\text{C}$	$\pm 4^{\circ}\text{C} \pm 1$ digit max.														
B below $400^{\circ}\text{C}$	Not specified.														
W	$\pm 0.3\%$ of indication value or $\pm 4^{\circ}\text{C}$ (whichever is larger) $\pm 1$ digit max.														
PL2	$\pm 0.3\%$ of indication value or $\pm 3^{\circ}\text{C}$ (whichever is larger)														

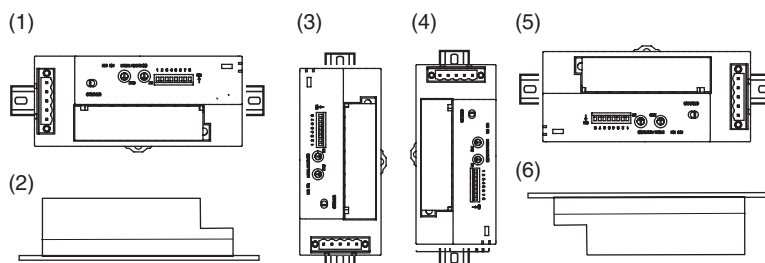

**Names and Functions of Parts**

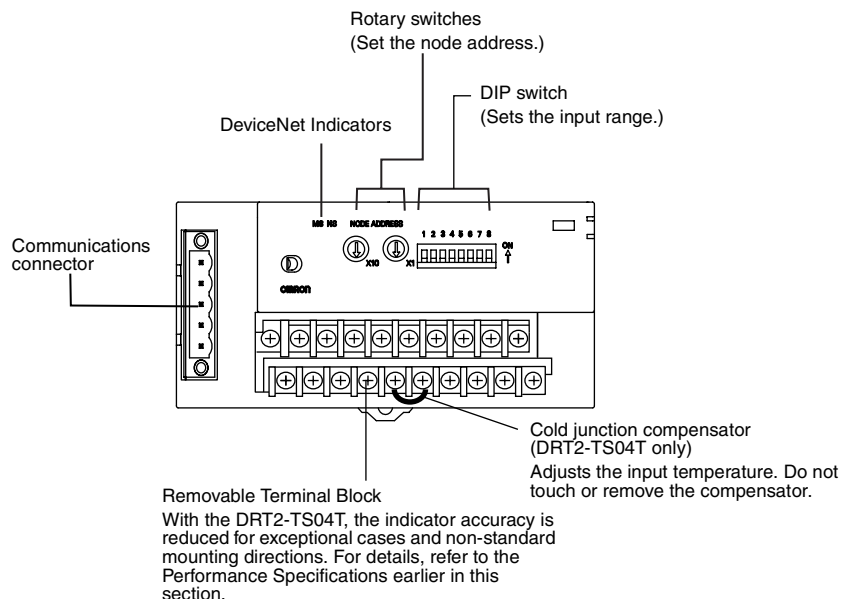

**Setting the Input Type**

**Setting with the DIP Switch**

The input type can be set using the DIP switch or the Configurator.

1 2 3 4 5 6 7 8

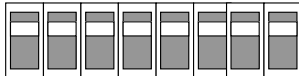

Set each pin according to the following table.

Pin No.	Setting	Specifications
SW1	The settings on pins 1 to 4 select the input type (input range). See the following table for the various combinations and corresponding input type settings.	This setting is enabled only when pin 8 is ON. Default setting: All pins OFF
SW2		
SW3		
SW4		
SW5	Sets the temperature display to normal or 1/100 display mode. (Displays data to 0.01 precision.)	ON: 1/100 display mode OFF: Normal display mode Default setting: OFF
SW6	Selects °C or °F display.	OFF: °C conversion ON: °F conversion Default setting: OFF
SW7	Sets the temperature display to DRT1-compatible 1/100 display mode. (Displays data to 0.01 precision.)	ON: DRT1 1/100 display mode OFF: Not used. When pin 7 is ON, the DRT1-compatible 1/100 display mode will be used, regardless of the setting of pin 5. Default setting: OFF
SW8	Selects the input type setting method. When the input type is set with the DIP switch, all 4 inputs are set to the same input type. To set different input types, use the Configurator to make the settings.	OFF: Set with Configurator. ON: Set with DIP switch. The other DIP switch pin settings are disabled when pin 8 is OFF. Default setting: OFF

**DRT2-TS04T**

SW1	SW2	SW3	SW4	Input type
OFF	OFF	OFF	OFF	R
ON	OFF	OFF	OFF	S
OFF	ON	OFF	OFF	K1
ON	ON	OFF	OFF	K2
OFF	OFF	ON	OFF	J1
ON	OFF	ON	OFF	J2
OFF	ON	ON	OFF	T
ON	ON	ON	OFF	E
OFF	OFF	OFF	ON	L1
ON	OFF	OFF	ON	L2
OFF	ON	OFF	ON	U
ON	ON	OFF	ON	N
OFF	OFF	ON	ON	W
ON	OFF	ON	ON	B
OFF	ON	ON	ON	PL2
ON	ON	ON	ON	Not used.

If the settings are incorrect, the MS Indicator will flash red and the Unit will not operate. In this case, make the settings again and reset the power supply.

**DRT2-TS04P**

SW1	SW2	SW3	SW4	Input type
OFF	OFF	Always OFF.		PT
ON	OFF			JPT
OFF	ON			PT2
ON	ON			JPT2

If the settings are incorrect, the MS Indicator will flash red and the Unit will not operate. In this case, make the settings again and reset the power supply.

- Note**
1. Always set pin 8 to ON if the DIP switch is used to set the ranges. If this pin is OFF, the DIP switch settings will not be enabled.
  2. The DIP switch settings are read when the power is turned ON.
  3. The 1/100 display mode and °C/°F display settings cannot be set individually for each input.
  4. When the display mode is set to 1/100 display mode with the DIP switch (pin 5 ON), the connection path must be set with the configurator. Refer to *7-6-2 Temperature Input Terminal Display Modes* for details. If “1/100 display” is not selected in the I/O data in the connection path settings from the Configurator, the temperature data will be 0.
  5. When a DRT1-series Temperature Input Terminal (DRT1-TS04T or DRT1-TS04P) is being replaced with one of these DRT2-series Slaves and the 1/100 display mode is being used, refer to the following table and set the appropriate display mode.

SW7	SW5	Display mode
OFF	OFF	Normal display
OFF	ON	1/100 display
ON	Not used.	DRT1-compatible 1/100 display

**Setting Using the DeviceNet Configurator**

Use the following procedure to set the input type for each input using the Configurator.

- 1,2,3... 1. Double-click the icon of the Slave to be set in the Main Window and open the Edit Device Parameters Window. (From the Maintenance Mode Window, click the right mouse button over the Slave icon and select **Parameters** and **Edit**.)
2. Select the Tab Page for the input where the sensor settings will be set.

- Select the desired sensor from the pull-down menu in the *Sensor Type* field.

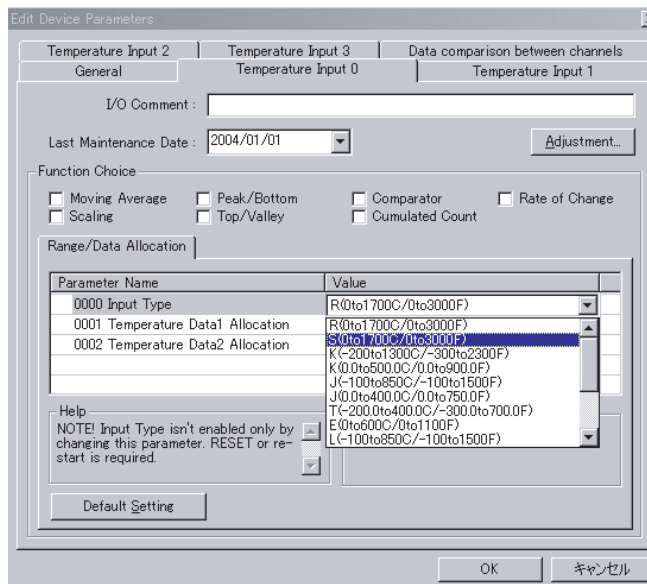

- Return to the **General** Tab, click the **Download** Button, and then click the **Reset** Button to reset the Unit.
- Click the **OK** Button and exit the window.

### Temperature Ranges by Input Type

The input type can be set with the DIP switch or Configurator. The following tables show the temperature ranges for each input type.

#### DRT2-TS04T

Input type	Temperature range (°C)	Temperature range (°F)
R	0 to 1,700	0 to 3,000
S	0 to 1,700	0 to 3,000
K1	-200 to 1,300	-300 to 2,300
K2	0.0 to 500.0	0.0 to 900.0
J1	-100 to 850	-100 to 1,500
J2	0.0 to 400.0	0.0 to 750.0
T	-200.0 to 400.0	-300.0 to 700.0
E	0 to 600	0 to 1,100
L1	-100 to 850	-100 to 1,500
L2	0.0 to 400.0	0.0 to 750.0
U	-200.0 to 400.0	-300.0 to 700.0
N	-200 to 1,300	-300 to 2,300
W	0 to 2,300	0 to 4,100
B	100 to 1,800	300 to 3,200
PL2	0 to 1,300	0 to 2,300

#### DRT2-TS04P

Input type	Temperature range (°C)	Temperature range (°F)
PT	-200.0 to 850.0	-300.0 to 1,500.0
JPT	-200.0 to 650.0	-300.0 to 1,200.0
PT2	-200.0 to 200.0	-300.0 to 380.0
JPT2	-200.0 to 200.0	-300.0 to 380.0

**Note** The temperature ranges listed above are the ranges in which the input accuracy is within the specified range.

**Convertible Temperature Ranges**

The convertible data range depends on the selected sensor, as shown in the following tables.

**DRT2-TS04T**

Input type	°C	Display	°F	Display
R	-20 to 1,720	FFEC to 06B8	-20 to 3,020	FFEC to 0BCC
S	-20 to 1,720	FFEC to 06B8	-20 to 3,020	FFEC to 0BCC
K1	-220 to 1,320	FF24 to 0528	-320 to 2,320	FEC0 to 0910
K2	-20.0 to 520.0	FF38 to 1450	-20.0 to 920.0	FF38 to 23F0
J1	-120 to 870	FF88 to 0366	-120 to 1,520	FF88 to 05F0
J2	-20.0 to 420.0	FF38 to 1068	-20.0 to 770.0	FF38 to 1E14
T	-220.0 to 420.0	F768 to 1068	-320.0 to 720.0	F380 to 1C20
E	-20 to 620	FFEC to 026C	-20 to 1,120	FFEC to 0460
L1	-120 to 870	FF88 to 0366	-120 to 1,520	FF88 to 05F0
L2	-20.0 to 420.0	FF38 to 1068	-20.0 to 770.0	FF38 to 1E14
U	-220.0 to 420.0	F768 to 1068	-320.0 to 720.0	F380 to 1C20
N	-220 to 1,320	FF24 to 0528	-320 to 2,320	FEC0 to 0910
W	-20 to 2,320	FFEC to 0910	-20 to 4,120	FFEC to 1018
B	80 to 1,820	0050 to 071C	280 to 3,220	0118 to 0C94
PL2	-20 to 1,320	FFEC to 0528	-20 to 2,320	FFEC to 0910

- Note**
1. The display data will be clamped at the minimum value when the value is below the minimum display value but higher than the value at which an off-wire condition is detected.
  2. When an off-wire condition is detected, the display data will be 7FFF. (In 1/100 display mode, the display data will be 7FFF FFFF.)

**DRT2-TS04T**

Input type	°C	Display	°F	Display
PT	-220.0 to 870.0	F768 to 21FC	-320.0 to 1,520.0	F380 to 3B60
JPT	-220.0 to 670.0	F768 to 1A2C	-320.0 to 1,220.0	F380 to 2FA8
PT2	-220.0 to 220.0	F768 to 0898	-320.0 to 400.0	F380 to 0FA0
JPT2	-220.0 to 220.0	F768 to 0898	-320.0 to 400.0	F380 to 0FA0

- Note**
1. If the Unit is subjected to sudden temperature changes, moisture may condense in the Unit and cause incorrect indications. If there is condensation, remove the Unit from service and keep it at a steady temperature for about 1 hour before using it again.
  2. If the input temperature exceeds the convertible range, the temperature data will be clamped at the minimum or maximum value. If the temperature exceeds the convertible range by a certain value, an off-wire condition (broken or disconnected input wire) will be detected and the temperature data will be set to 7FFF. If the input temperature returns to the convertible range, the off-wire detection function will be reset automatically and normal conversion data will be stored.



**Terminal Arrangement**

**DRT2-TS04T**

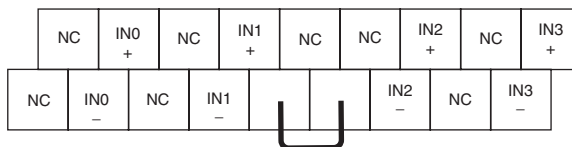

Cold junction compensator  
 Adjusts the input temperature. Do not touch or remove the compensator. The correct temperature data will not be displayed if the compensator is disturbed.

**DRT2-TS04P**

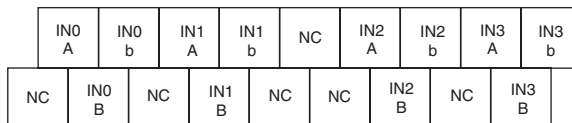

**Wiring**

DRT2-TS04T  
 Thermocouple input

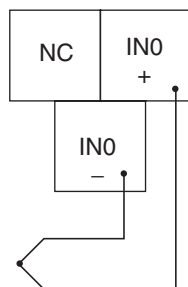

DRT2-TS04P  
 Platinum-resistance thermometer input

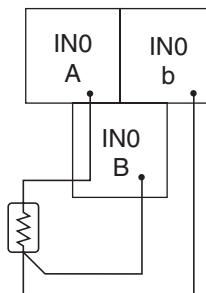

**Note** When all of the inputs are not being used, an off-wire condition may be detected in the unused, open input terminal. To prevent an off-wire detection, wire the unused input terminals as shown in the following diagram.

DRT2-TS04T  
 Thermocouple input

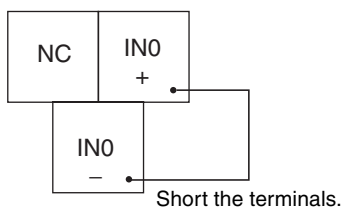

DRT2-TS04P  
 Platinum-resistance thermometer input

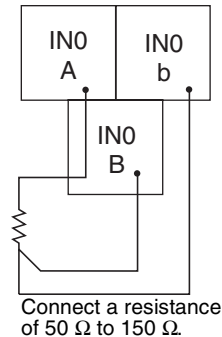

## 7-6-2 Temperature Input Terminal Display Modes

### Normal Display Mode (Default Setting)

The input temperature data is converted to 4-digit hexadecimal digital data and transmitted to the Master. If the conversion data is negative, the negative value is expressed as the two's complement.

The four inputs occupy 4 words in the Master, as shown in the following diagram. If the input type's data has 0.1 digits, the value transmitted to the master is 10 times the actual value. (The decimal point is omitted.)

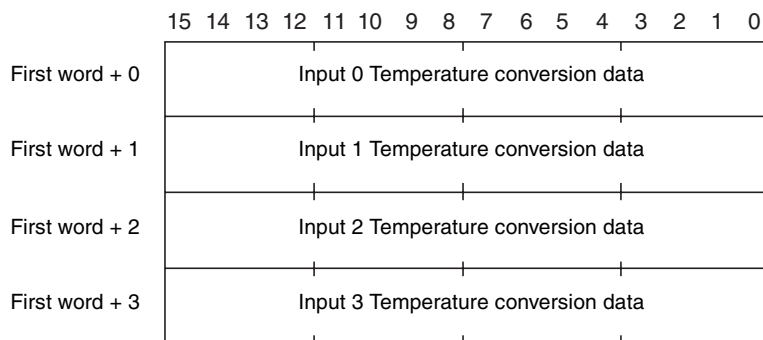

- Example 1: R type thermocouple at 1,000°C  
1,000 converted to hexadecimal → 03E8 hex
- Example 2: U type thermocouple at 350.0°C  
 $350 \times 10 = 3,500$  converted to hexadecimal → 0DAC hex

### 1/100 Display Mode

The input temperature data for all input types is transmitted to the Master as data with precision to 0.01 digits. The temperature data is multiplied by 100 and converted to 8-digit hexadecimal digital data (four long values).

If the conversion data is negative, the negative value is expressed as the two's complement.

The four inputs occupy 8 words in the Master, as shown in the following diagram.

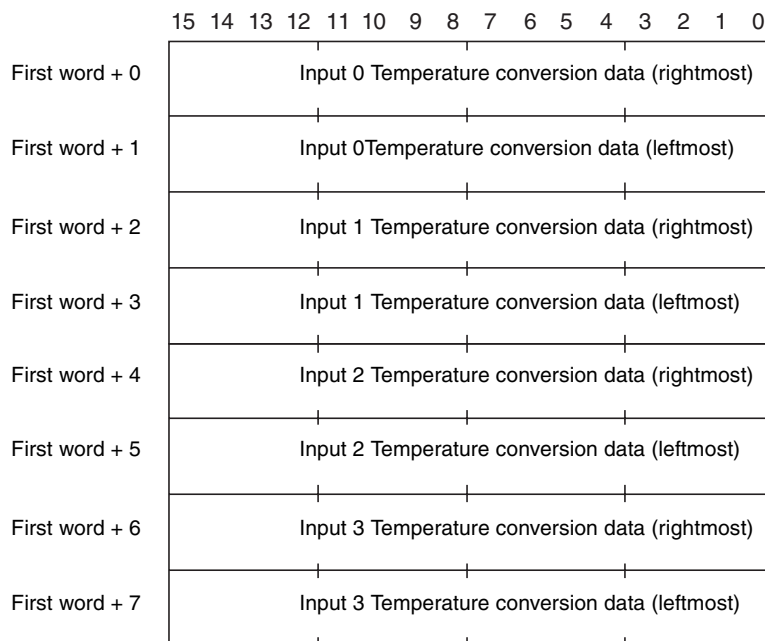

- Example 1: 850.00°C  
850 × 100 = 85,000 converted to hexadecimal → 0001 4C08 hex  
Rightmost data = 4C08 hex; Leftmost data = 0001 hex
- Example 2: -200.00°C  
-200 × 100 = -20,000 converted to hexadecimal → FFFF B1E0 hex  
Rightmost data = B1E0 hex; Leftmost data = FFFF hex

### Setting the 1/100 Display Mode

#### ■ Using the Slave's Default Connection Path

- 1,2,3...**
1. Turn ON pin 5 of the Slave's DIP switch. (Select 1/100 display mode.)
  2. Turn ON the Master and Slave power supplies. At this point, the Slave will not be in 1/100 display mode.
  3. Double-click the icon of the Slave to be set in the Main Window and open the Edit Device Parameters Window.

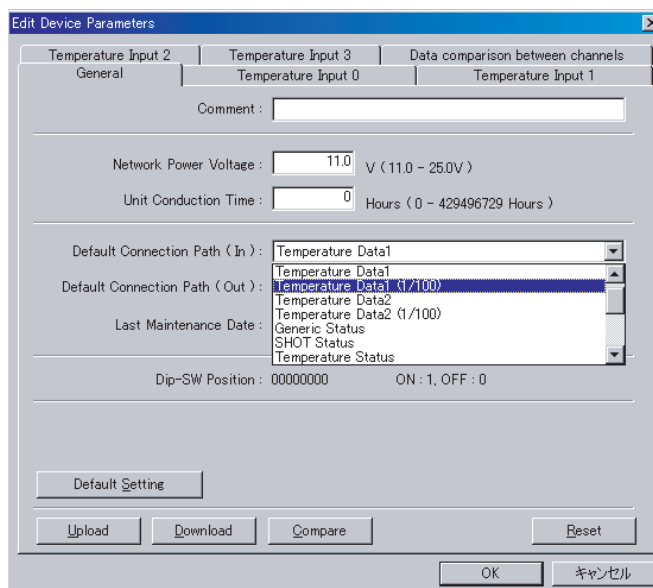

4. Select **Temperature Data1 (1/100)** or **Temperature Data2 (1/100)** from the pull-down menu in the *Default Connection Path (In)* field. Click the **Download** Button and then click the **Reset** Button to reset the Unit.

#### ■ Using the Master's Connection Path

- 1,2,3...**
1. Turn ON pin 5 of the Slave's DIP switch. (Select 1/100 display mode.)
  2. Turn ON the Master and Slave power supplies. At this point, the Slave will not be in 1/100 display mode.
  3. Double-click the icon of the Master to be set in the Main Window and open the Edit Device Parameters Window.

- Select a Slave in the *Register Device* list and click the **Advanced Setup** Button to open the Advanced setting Window.

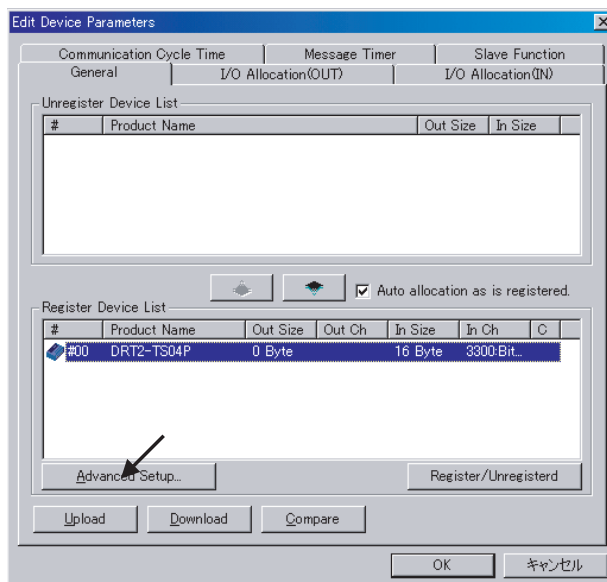

- Click the **Connection** Tab, select **User Setup**, and select the type of connection being used. Select **Temp. data1 (4B/EU)** from the pull-down menu in the *Con. (Connection) Path* field for input and then click the **OK** Button.

**Note** The 1/100 display mode cannot be selected when a Bit-Strobe connection is being used.

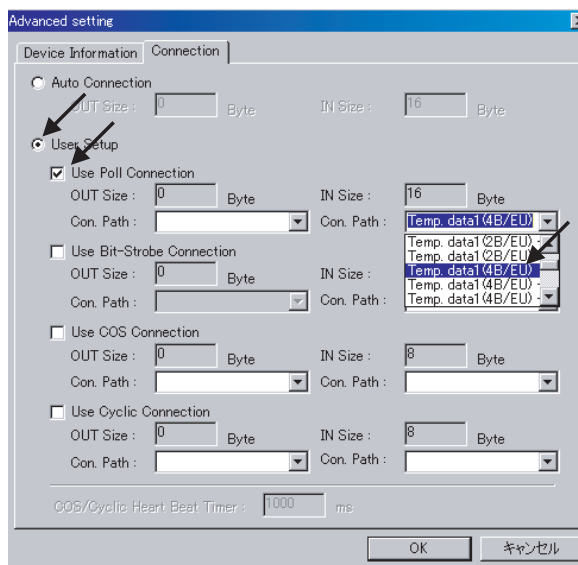

- Return to the Edit Device Parameters Window and click the **I/O Allocation (IN)** Tab. Click the **Edit** Button to display the Edit I/O Allocate Window.

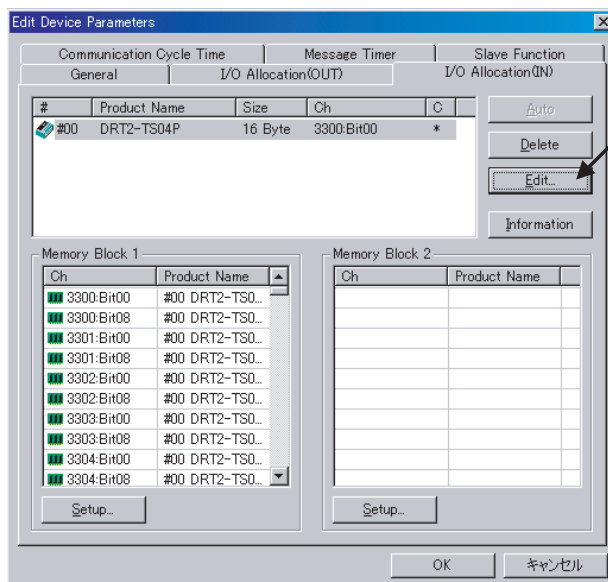

- Set the allocated words in the Edit I/O Allocate Window,

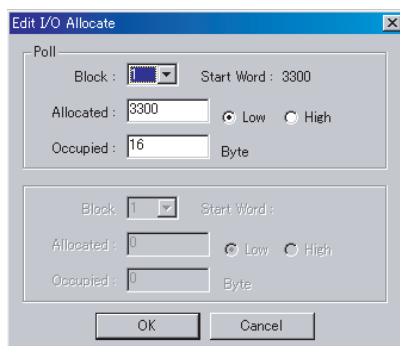

- Click the **General** Tab in the Edit Device Parameters Window and click the **Download** Button. The Master will be reset and will restart with the specified connection type, I/O data, and allocated words.

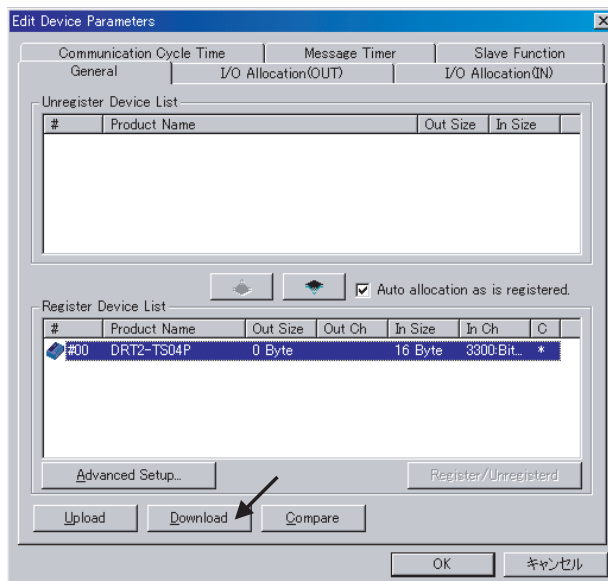

- Note**
1. After selecting 1/100 display mode by turning ON pin 5 of the DIP switch, the 1/100 display mode must be enabled by setting the connection path with the Configurator.  
If the normal display mode is selected for the I/O data in the Configurator, the temperature data will be 0.
  2. In 1/100 display mode, the temperature data will be converted to two places below the decimal even though the actual resolution is not 0.01°C (or °F). Consequently, the 0.1°C/°F or 0.01°C/°F display digits may jump back and forth between values. Treat any values displayed beyond the specified input resolution as reference data.

**DRT1-compatible**  
**1/100 Display Mode**

The input temperature data for all input types is transmitted to the Master as data with precision to 0.01 digits. In DRT1-compatible 1/100 display mode, a single temperature data value is multiplied by 100 and transmitted to the Master as 6-digit signed hexadecimal data (4 integer digits and 2 digits below the decimal point). At this point, the data is divided into two words and the two words are transmitted alternately at 125-ms intervals (each word contains one part of the temperature value).

The four inputs occupy 4 words in the Master, as shown in the following diagram.

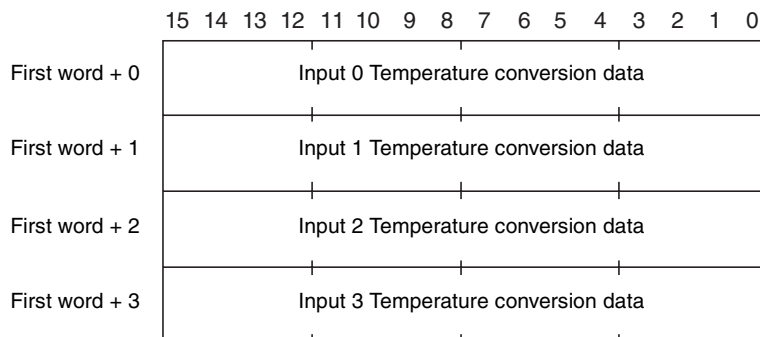

The following diagram shows how the temperature data is divided into two words and the structure of each word.

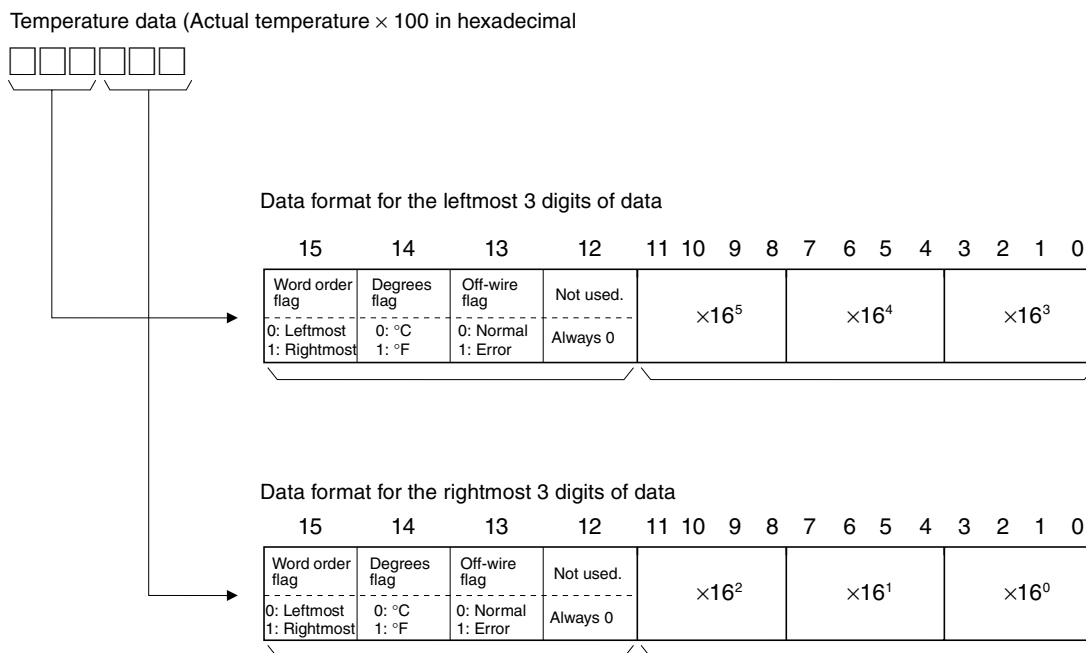

- Word order flag: Indicates whether the word contains the rightmost or leftmost 3 digits.
- Degrees flag: Indicates whether the temperature units are °C or °F.
- Off-wire flag: A value of 1 indicates an off-wire condition was detected. In this case, the leftmost 3 digits will be 7FF and the rightmost digits will be FFF.

The rightmost 3 digits and leftmost 3 digits are sent to the Master alternately in 125-ms intervals, as shown in the following diagram.

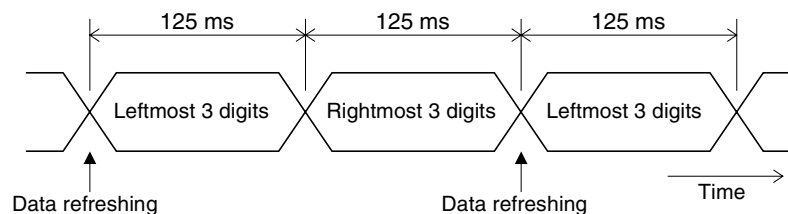

**Example 1: 1130.25 °C**

Temperature × 100: 113,025  
 Transmitted value: 01B981 (113,025 in hexadecimal)

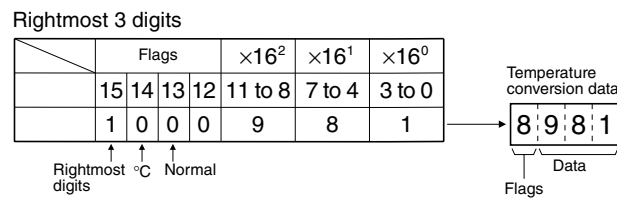
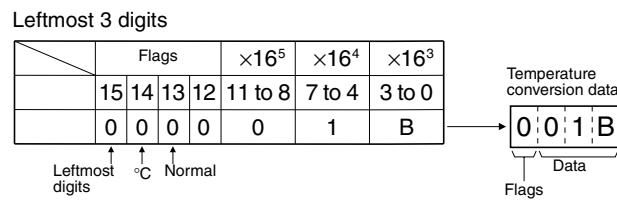

**Example 2: -100.12°C**

Temperature × 100: -10,012  
 Transmitted value: FFD8E4 (-10,012 in hexadecimal)

Leftmost 3 digits

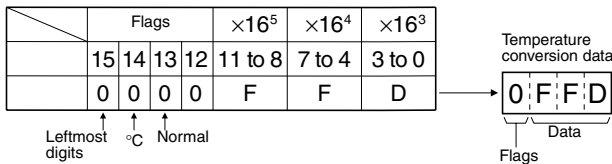

Rightmost 3 digits

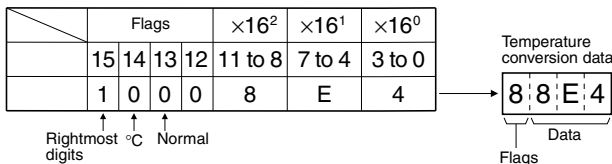

**Example 3: -200.12°C**

Temperature × 100: -20,012  
 Transmitted value: FFB1D4 (-20,012 in hexadecimal)

Leftmost 3 digits

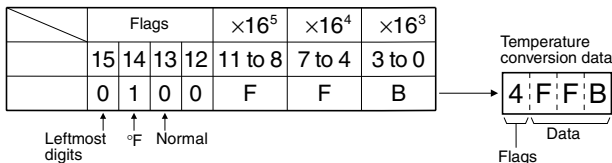

Rightmost 3 digits

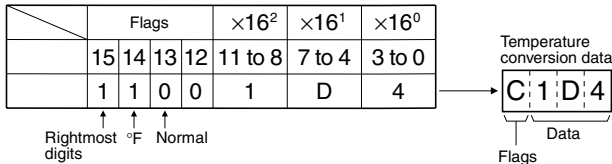

**Example 4: Input Error (Off-wire) with °F Temperature Data**

Transmitted value: 7FFFFFFF

Leftmost 3 digits

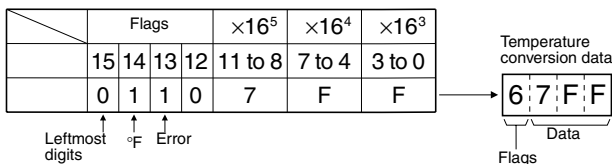

Rightmost 3 digits

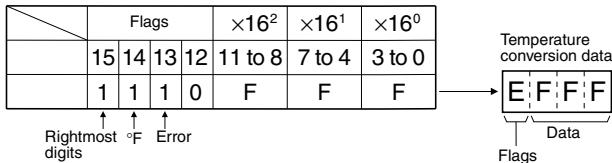

**Note** 1. Data is transmitted in the order: leftmost 3 digits → rightmost 3 digits. When reading the temperature data in the program, always read it in the same order (leftmost 3 digits → rightmost 3 digits).



- Consider the PLC's cycle time and communications time and make adjustments if necessary so that the data read cycle is less than 125 ms. If the data read cycle exceeds 125 ms, it will not be possible to read the correct data.

■ **Sample Program (for DRT2-TS04T or DRT2-TS04P)**

The following sample program is a CS1 ladder program for use with a Temperature Input Terminal operating in DRT1-compatible 1/100 display mode.

**Temperature Input Terminal's Settings**

Allocated words: CIO 3300 to CIO 3303

Display mode: DRT1-compatible 1/100 display mode

**Operation**

The input 0 temperature data is multiplied by 100 and stored in CIO 0030 to CIO 0032, as shown in the following diagram.

	15	to	12	11	to	8	7	to	4	3	2	1	0
Word 30	×16 <sup>3</sup>			×16 <sup>2</sup>			×16 <sup>1</sup>			×16 <sup>0</sup>			
Word 31	×16 <sup>7</sup>			×16 <sup>6</sup>			×16 <sup>5</sup>			×16 <sup>4</sup>			
Word 32										0	Degrees flag	Off-wire flag	0

Degrees flag: 0 for °C, 1 for °F

Off-wire flag: 0 for normal, 1 for an off-wire error

The content of CIO 0030 and CIO 0031 is treated as 8-digit hexadecimal data.

**Sample Program**

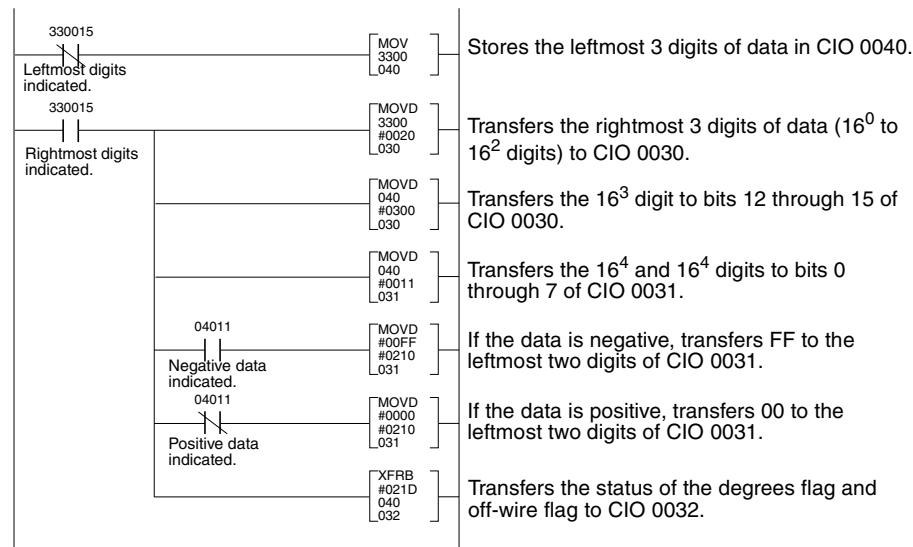

**Dimensions**

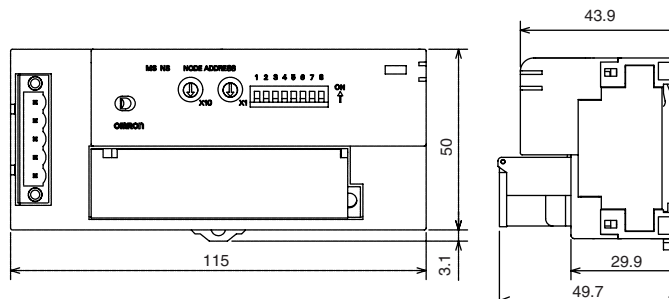

**7-6-3 I/O Data Selection and Allocation**

**Selecting Temperature Data**

Up to two of the six resulting values can be selected to allocate in the Master (one type each for Temperature Data 1 and Temperature Data 2). Select from analog input value, peak value, bottom value, top value, valley value, and rate of change. The selected data is allocated in the Master individually or in combination with Status Flags. The following methods can be used to select the temperature data.

**Using the Configurator**

1,2,3...

1. Double-click the icon of the Slave to be set in the Main Window and open the Edit Device Parameters Window. (From the Maintenance Mode Window, click the right mouse button over the Slave icon and select **Parameters** and **Edit**.)
2. Click the Tab Page for the input where temperature data is to be selected. From the data on which math operations have been performed, select two types of data from the pull-down menu as Temperature Data 1 and Temperature Data 2.

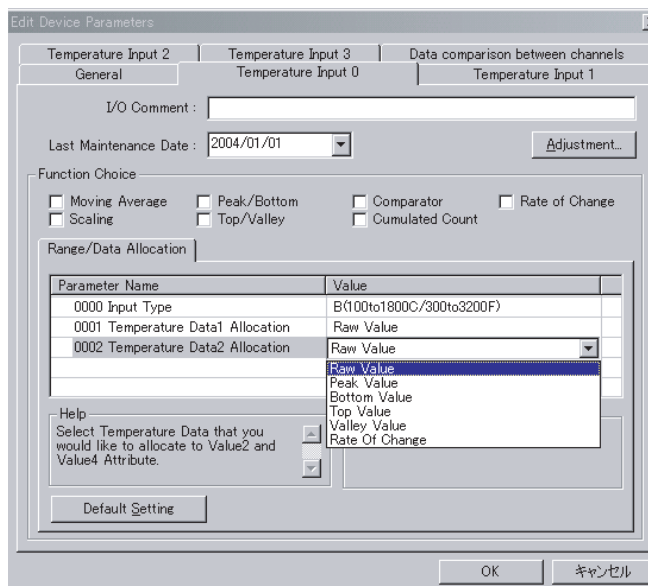

3. Return to the **General** Tab, click the **Download** Button, and then click the **Reset** Button to reset the Unit.
4. Click the **OK** Button and exit the window.

**Allocating I/O Data in the Master**

Use one of the following methods to select data for allocating in the Master and then perform remote I/O communications.

- 1,2,3...**
1. Allocating only temperature input values (default I/O data) in the Master.
  2. Allocating selected I/O data (patterns) in the Master (fixed I/O data combinations).
  3. Allocating user-defined I/O data in the Master (user-defined I/O data combinations).

■ **Allocating Temperature Input Values (Default I/O Data) Only**

When using the Temperature Input Terminal’s default settings, only the temperature input values are selected as I/O data and allocated in the four words (eight bytes) of the Master’s IN Area, as shown in the following diagram. The data is also be allocated to 4 words when the temperature input value is set to 1/100 display by setting the Slave’s DIP switch to DRT1-compatible 1/100 display mode.

<b>15</b>		<b>0</b>
	<b>Temperature input value for Input 0</b>	
	<b>Temperature input value for Input 1</b>	
	<b>Temperature input value for Input 2</b>	
	<b>Temperature input value for Input 3</b>	

When the temperature input value has been set for “1/100 display mode” with the Configurator, eight words (sixteen bytes) are allocated in the Master’s IN Area, as shown in the following diagram.

<b>15</b>		<b>0</b>
	<b>Temperature input value for Input 0</b>	
	<b>Temperature input value for Input 0</b>	
	<b>Temperature input value for Input 1</b>	
	<b>Temperature input value for Input 1</b>	
	<b>Temperature input value for Input 2</b>	
	<b>Temperature input value for Input 2</b>	
	<b>Temperature input value for Input 3</b>	
	<b>Temperature input value for Input 3</b>	

■ **Allocating Selected I/O Data (Patterns)**

The temperature data selected from the data on which math operations have been performed is combined with other data such as Status Flags and allocated in the Master.

Example: Allocating Temperature Data 1 + Top/Valley Detection Timing Flags in the Master.

<b>15</b>		<b>8</b>	<b>7</b>		<b>0</b>
	<b>Temperature Data 1 for Input 0</b>				
	<b>Temperature Data 1 for Input 1</b>				
	<b>Temperature Data 1 for Input 2</b>				
	<b>Temperature Data 1 for Input 3</b>				
	<b>Top Detection Timing Flag</b>		<b>Valley Detection Timing Flag</b>		

The following method can be used to allocate data from the Configurator.

## Setting Using the DeviceNet Configurator

- 1,2,3...**
1. Double-click the icon of the Temperature Input Terminal to be set in the Main Window and open the Edit Device Parameters Window. (From the Maintenance Mode Window, click the right mouse button over the Slave icon and select **Parameters** and **Edit**.)
  2. Click the **General** Tab and select the desired I/O data (pattern) from the pull-down menu under the *Default Connection Path (in)* field. In the following example, the Generic Status flags are allocated.

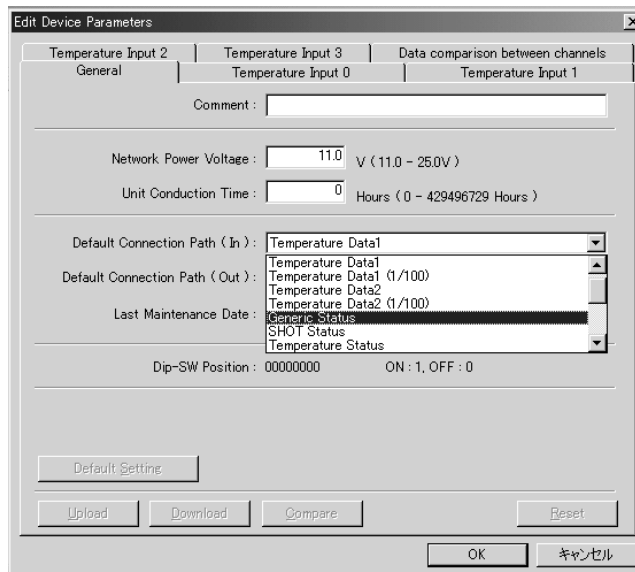

3. Click the **Download** Button and then click the **Reset** Button to reset the Unit.
4. Click the **OK** Button and exit the window.

#### ■ Allocating User-defined I/O Data (Any I/O Data Combination)

The temperature data selected from the data on which math operations have been performed can be allocated in the Master with other data such as Status Flags, in any combination. The Configurator can be used to allocate two data patterns in the Master with any combination.

This method is supported by CS/CJ-series DeviceNet Master Units only.

**Note** Priority is given to settings in the Master, so the setting for the Slave's default connection path is not required.

Use the following method to allocate data from the Configurator.

- 1,2,3...**
1. Double-click the icon of the Master Unit to which I/O will be allocated and open the Edit Device Parameters Window. (From the Maintenance Mode Window, click the right mouse button over the Master Unit icon and select **Parameters** and **Edit**.)

- Click the **General** Tab, select the Temperature Input Terminal to be set, and click the **Advanced Setup** Button.

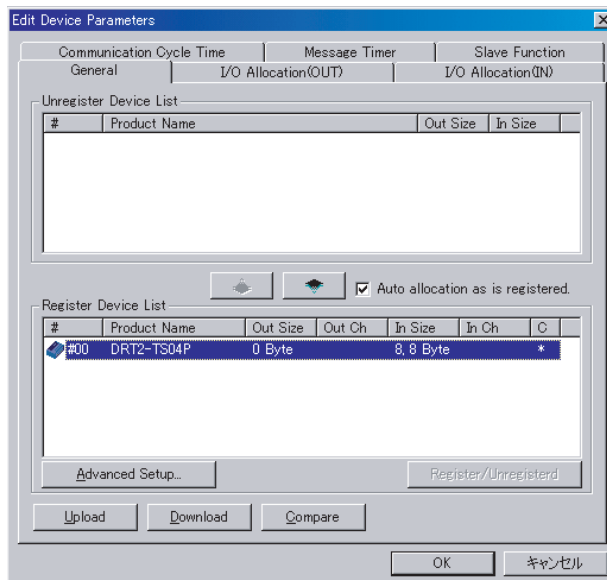

- Click the **Connection** Tab, and select **User Setup**. Select **Use Poll Connection**, and then select the I/O data (pattern) from the pull-down menu for the connection path. In the same way, select **Use Cyclic Connection**, and then select any I/O data (pattern) from the pull-down menu for the connection path.

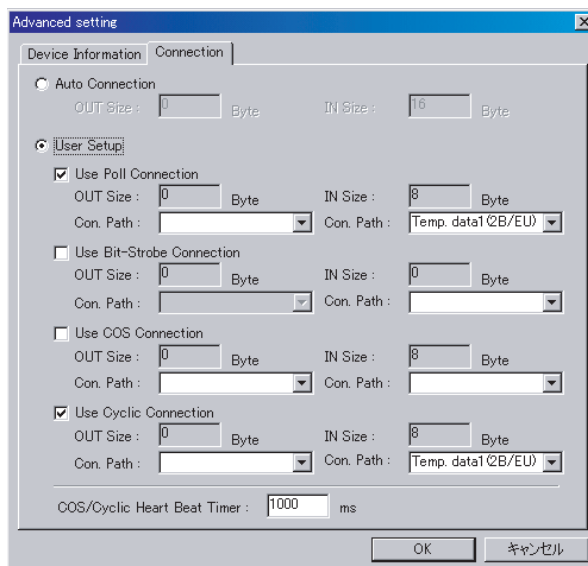

- Click the **OK** Button and exit the window.
- Click the **I/O Allocation (IN)** Tab and edit the I/O allocations. Select the Smart Slave to be set and click the **Edit** Button to display the Edit I/O Allocate Window.

Set the *Poll* settings to block 1, allocated 3300 (word CIO 3300).  
 Set the *Cyclic* settings to block 2, allocated 3500 (word CIO 3500).

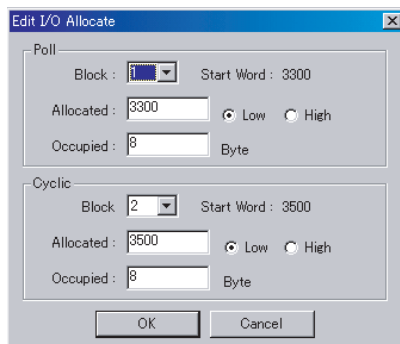

- Click the **OK** Button and use the following window to confirm that I/O has been allocated correctly.

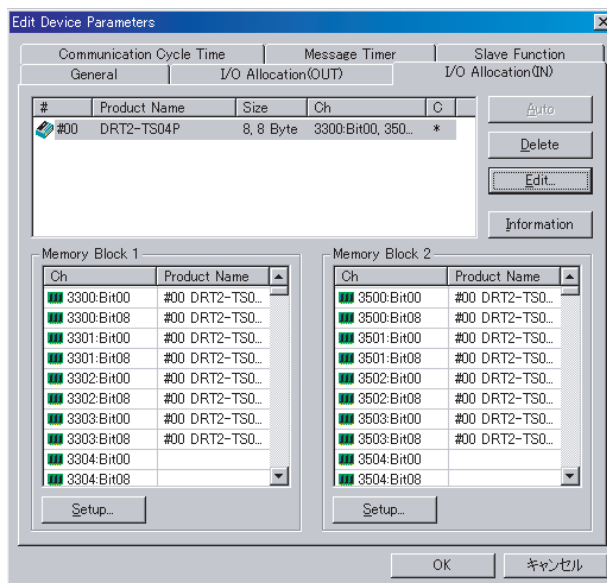

- Click the **OK** Button, return to the **General** Tab, and click the **Download** Button.

### I/O Data

#### **Temperature Data 1 (Instance 104 or 108)**

Temperature Data 1 is used to monitor the temperature input values. The temperature input value is allocated as the default setting, but any one of temperature input value, peak value, bottom value, top value, valley value or rate of change can be selected as allocation data.

**Note** The comparator function can be used for the data allocated in Temperature Data 1.

The following tables show the data format used for allocating data in the Master. Data is allocated as two's complements.

**Normal Display (Instance 104)**

15	0
Temperature Data 1 for Input 0	
Temperature Data 1 for Input 1	
Temperature Data 1 for Input 2	
Temperature Data 1 for Input 3	

**1/100 Display Mode (Instance 108)**

15	0
Temperature Data 1 for Input 0	
Temperature Data 1 for Input 0	
Temperature Data 1 for Input 1	
Temperature Data 1 for Input 1	
Temperature Data 1 for Input 2	
Temperature Data 1 for Input 2	
Temperature Data 1 for Input 3	
Temperature Data 1 for Input 3	

**Temperature Data 2 (Instance 114 or 118)**

Temperature Data 2 is used to monitor other temperature data in addition to that in Temperature Data 1. Select one type of following data other than that allocated for Temperature Data 1: Temperature input value, peak value, bottom value, top value, valley value, or rate of change.

**Note** The “Data Comparison between Channels” function, which detects temperature differences between different input channels, can be used with the values allocated as Temperature Data 2.

The following tables show the data format used for allocating data in the Master. Data is allocated as two’s complements.

**Normal Display (Instance 114)**

15	0
Temperature Data 2 for Input 0	
Temperature Data 2 for Input 1	
Temperature Data 2 for Input 2	
Temperature Data 2 for Input 3	

**Note** When the DRT1-compatible 1/100 display mode is being used for 1/100 display, only 4 words (8 bytes) are occupied in the Master as well.

**1/100 Display Mode (Instance 118)**

15	0
Temperature Data 2 for Input 0	
Temperature Data 2 for Input 0	
Temperature Data 2 for Input 1	
Temperature Data 2 for Input 1	
Temperature Data 2 for Input 2	
Temperature Data 2 for Input 2	
Temperature Data 2 for Input 3	
Temperature Data 2 for Input 3	

**Generic Status Flags (Instance 121)**

The Generic Status Flags are used to monitor flags that indicate maintenance information (Network Power Voltage Monitor Flag, Unit Conduction Time Monitor Flag, and Temperature Data Cumulative Counter Flag). The following data format is used for allocating flags in the Master (1 byte).

<b>Bit 7</b>	<b>Bit 6</b>	<b>Bit 5</b>	<b>Bit 4</b>	<b>Bit 3</b>	<b>Bit 2</b>	<b>Bit 1</b>	<b>Bit 0</b>
<b>CCB</b>	<b>0</b>	<b>MRF</b>	<b>CCW</b>	<b>RHW</b>	<b>NPW</b>	<b>0</b>	<b>0</b>

The details of each bit are shown in the following table.

Bit	Abbreviation	Name	Details
0	---	---	Reserved. (Always 0.)
1	---	---	Reserved. (Always 0.)
2	<b>NPW</b>	Network Power Voltage Monitor Flag	Turns ON when the Network power level drops below the set monitor value.
3	<b>RHW</b>	Unit Conduction Time Monitor Flag	Turns ON when the Unit ON time exceeds the set monitor value.
4	<b>CCW</b>	Temperature Data Cumulative Counter Flag	Turns ON when any of the cumulated analog values exceeds the set monitor value.
5	<b>MRF</b>	Unit Error Flag	Turns ON when analog conversion stops due to a Unit error.
6	---	---	Reserved. (Always 0.)
7	---	Cold Junction Compensator Off-wire Flag	Turns ON when the cold junction compensator is broken or off-wire. (DRT2-TS04T only)

The following format is used when Generic Status Flags are allocated, starting from the rightmost byte of the Master.

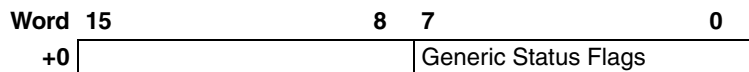

**Top/Valley Detection Timing Flags (Instance 122)**

These flags turn ON for the one-shot time when detecting the top or valley for the top/valley hold function.

These flags are used to time reading the values held as the top and valley values at the Master. The following data format is used when these flags are allocated in the Master (2 bytes).

	<b>Bit 7</b>	<b>Bit 6</b>	<b>Bit 5</b>	<b>Bit 4</b>	<b>Bit 3</b>	<b>Bit 2</b>	<b>Bit 1</b>	<b>Bit 0</b>
+0	0	0	0	0	V_ST3	V_ST2	V_ST1	V_ST0
+1	0	0	0	0	T_ST3	T_ST2	T_ST1	T_ST0

The details of each byte are shown in the following table.

Byte	Abbreviation	Name	Details
+0	V_STx	Valley Detection Timing Flag	Turns ON when a valley is detected by the valley hold function and then turns OFF after the one-shot time has elapsed.
+1	T_STx	Top Detection Timing Flag	Turns ON when a top is detected by the top hold function and then turns OFF after the one-shot time has elapsed.

**Note** The one-shot time can be changed. For details, refer to the one-shot time settings for the top/valley hold function.



The following format is used when the Top/Valley Detection Timing Flags are allocated, starting from the rightmost byte of the Master

Word	15	12	11	8	7	4	3	0
+0			Top Detection Timing Flag				Valley Detection Timing Flag	

**Analog Status Flags (Instance 134)**

The Analog Status Flags include allocations for the Comparator Result Flag, the Top/Valley Detection Timing Flags, and the Off-wire Detection Flags. These flags are used for detection and monitoring.

The data format used for each byte when these flags are allocated in the Master is shown below (4 bytes).

	Bit 7	Bit 6	Bit 5	Bit 4	Bit 3	Bit 2	Bit 1	Bit 0	
+0	BW0	T_ST0	V_ST0	HH	H	PS0	L	LL	Input 0
+1	BW1	T_ST1	V_ST1	HH	H	PS1	L	LL	Input 1
+2	BW2	T_ST2	V_ST2	HH	H	PS2	L	LL	Input 2
+3	BW3	T_ST3	V_ST3	HH	H	PS3	L	LL	Input 3

The details for each bit are shown in the following table.

Bit	Abbreviation	Name	Details
0	LLx	Comparator result	Low Low Limit Alarm Flag Turns ON when the value of data allocated in Temperature Data 1 drops below the Low Low Limit alarm setting.
1	Lx		Low Limit Alarm Flag Turns ON when the value of data allocated in Temperature Data 1 drops below the Low Limit alarm setting.
2	PSx		Normal Flag (pass signal) Turns ON when none of the alarms (High High Limit, High Limit, Low Low Limit, and Low Limit) have been output.
3	Hx		High Limit Alarm Flag Turns ON when the value of data allocated in Temperature Data 1 exceeds the High Limit alarm setting.
4	HHx		High High Limit Alarm Flag Turns ON when the value of data allocated in Temperature Data 1 exceeds the High High Limit alarm setting.
5	V_STx	Top/valley detection timing	Valley Detection Timing Flag Used with the valley hold function. Turns ON when a valley is detected, and turns OFF after the one-shot time has lapsed.
6	T_STx		Top Detection Timing Flag Used with the top hold function. Turns ON when a top is detected, and turns OFF after the one-shot time has lapsed.
7	BWx	Off-wire Detection Flag	Turns ON when a disconnection is detected.

The following format is used when Analog Status Flags are allocated, starting from the rightmost byte of the Master.

	Word 15	8	7	0
+0	For Input 1		For Input 0	
+1	For Input 3		For Input 2	

**Temperature Data 1 +  
Temperature Data 2  
(Instance 144 or 148)**

This data pattern consists of Temperature Data 1 followed by Temperature Data 2 and is allocated in the Master using the following data format. Negative data values are given as two's complements

**Normal Display (Instance 144)**

	Word 15	0
+0	Temperature Data 1 for Input 0	
+1	Temperature Data 1 for Input 1	
+2	Temperature Data 1 for Input 2	
+3	Temperature Data 1 for Input 3	
+4	Temperature Data 2 for Input 0	
+5	Temperature Data 2 for Input 1	
+6	Temperature Data 2 for Input 2	
+7	Temperature Data 2 for Input 3	

**1/100 Display Mode (Instance 148)**

	Word 15	0
+0	Temperature Data 1 for Input 0	
+1	Temperature Data 1 for Input 0	
+2	Temperature Data 1 for Input 1	
+3	Temperature Data 1 for Input 1	
+4	Temperature Data 1 for Input 2	
+5	Temperature Data 1 for Input 2	
+6	Temperature Data 1 for Input 3	
+7	Temperature Data 1 for Input 3	
+8	Temperature Data 2 for Input 0	
+9	Temperature Data 2 for Input 0	
+10	Temperature Data 2 for Input 1	
+11	Temperature Data 2 for Input 1	
+12	Temperature Data 2 for Input 2	
+13	Temperature Data 2 for Input 2	
+14	Temperature Data 2 for Input 3	
+15	Temperature Data 2 for Input 3	

**Top/Valley Detection  
Timing Flags + Generic  
Status Flags  
(Instance 151)**

This data pattern consists of the Top/Valley Detection Timing Flags followed by Generic Status Flags and is allocated in the Master using the following data format, shown by byte (3 bytes).

	Bit 7	Bit 6	Bit 5	Bit 4	Bit 3	Bit 2	Bit 1	Bit 0
+0	0	0	0	0	V_ST3	V_ST2	V_ST1	V_ST0
+1	0	0	0	0	T_ST3	T_ST2	T_ST1	T_ST0
+2	0	0	MRF	CCW	RHW	NPW	0	0

The following format is used when this data pattern is allocated, starting from the rightmost byte of the Master.

<b>Word 15</b>	<b>8</b>	<b>7</b>	<b>0</b>
+0		Top Detection Timing Flags	Valley Detection Timing Flags
+1	Generic Status Flags		

**Analog Status Flags + Generic Status Flags (Instance 164)**

This data pattern consists of Analog Status Flags followed by Generic Status Flags and is allocated in the Master using the following data format, shown by byte (5 bytes).

	<b>Bit 7</b>	<b>Bit 6</b>	<b>Bit 5</b>	<b>Bit 4</b>	<b>Bit 3</b>	<b>Bit 2</b>	<b>Bit 1</b>	<b>Bit 0</b>	
+0	BD0	T_ST0	V_ST0	HH	H	PS0	LL	L	Input 0
+1	BD1	T_ST1	V_ST1	HH	H	PS1	LL	L	Input 1
+2	BD2	T_ST2	V_ST2	HH	H	PS2	LL	L	Input 2
+3	BD3	T_ST3	V_ST3	HH	H	PS3	LL	L	Input 3
+4	0	0	MRF	CCW	RHW	NPW	0	0	

The following format is used when this data pattern is allocated, starting from the rightmost byte of the Master.

<b>Word 15</b>	<b>8</b>	<b>7</b>	<b>0</b>
+0	For Input 1		For Input 0
+1	For Input 3		For Input 2
+2	Generic Status Flags		

**Temperature Data 1 + Top/Valley Detection Timing Flags (Instance 174 or 178)**

This data pattern consists of Temperature Data 1 followed by the Top/Valley Detection Timing Flags and is allocated in the Master using the following data format (10 bytes).

**Normal Display (Instance 174)**

	<b>Bit 7</b>	<b>Bit 6</b>	<b>Bit 5</b>	<b>Bit 4</b>	<b>Bit 3</b>	<b>Bit 2</b>	<b>Bit 1</b>	<b>Bit 0</b>	
+0	Temperature Data 1 for Input 0								
+1	Temperature Data 1 for Input 1								
+2	Temperature Data 1 for Input 2								
+3	Temperature Data 1 for Input 3								
+4	Temperature Data 1 for Input 3								
+5	Temperature Data 1 for Input 3								
+6	Temperature Data 1 for Input 3								
+7	Temperature Data 1 for Input 3								
+8	0	0	0	0	V_ST3	V_ST2	V_ST1	V_ST0	
+9	0	0	0	0	T_ST3	T_ST2	T_ST1	T_ST0	

The following format is used when this data pattern is allocated, starting from the rightmost byte of the Master.

<b>Word 15</b>	<b>8</b>	<b>7</b>	<b>0</b>
+0	Temperature Data 1 for Input 0		
+1	Temperature Data 1 for Input 1		
+2	Temperature Data 1 for Input 2		
+3	Temperature Data 1 for Input 3		
+4		Top Detection Timing Flags	Valley Detection Timing Flags

**1/100 Display (Instance 178)**

	Bit 7	Bit 6	Bit 5	Bit 4	Bit 3	Bit 2	Bit 1	Bit 0
+0	Temperature Data 1 for Input 0							
+1	Temperature Data 1 for Input 0							
+2	Temperature Data 1 for Input 0							
+3	Temperature Data 1 for Input 0							
+4	Temperature Data 1 for Input 1							
+5	Temperature Data 1 for Input 1							
+6	Temperature Data 1 for Input 1							
+7	Temperature Data 1 for Input 1							
+8	Temperature Data 1 for Input 2							
+9	Temperature Data 1 for Input 2							
+10	Temperature Data 1 for Input 2							
+11	Temperature Data 1 for Input 2							
+12	Temperature Data 1 for Input 3							
+13	Temperature Data 1 for Input 3							
+14	Temperature Data 1 for Input 3							
+15	Temperature Data 1 for Input 3							
+16	0	0	0	0	V_ST3	V_ST2	V_ST1	V_ST0
+17	0	0	0	0	T_ST3	T_ST2	T_ST1	T_ST0

The following format is used when this data pattern is allocated, starting from the rightmost byte of the Master.

Word	15	8	7	0
+0	Temperature Data 1 for Input 0			
+1	Temperature Data 1 for Input 0			
+2	Temperature Data 1 for Input 1			
+3	Temperature Data 1 for Input 1			
+4	Temperature Data 1 for Input 2			
+5	Temperature Data 1 for Input 2			
+6	Temperature Data 1 for Input 3			
+7	Temperature Data 1 for Input 3			
+8	Top Detection Timing Flags		Valley Detection Timing Flags	

**Temperature Data 1 + Top/Valley Detection Timing Flags + Generic Status Flags (Instance 184 or 188)**

This data pattern consists of Analog Data 1 followed by the Top/Valley Detection Timing Flags and then the Generic Status Flags and is allocated in the Master using the following data format, shown by byte (11 bytes).

**Normal Display (Instance 184)**

	Bit 7	Bit 6	Bit 5	Bit 4	Bit 3	Bit 2	Bit 1	Bit 0
+0	Temperature Data 1 for Input 0							
+1	Temperature Data 1 for Input 1							
+2	Temperature Data 1 for Input 2							
+3	Temperature Data 1 for Input 3							
+4	Temperature Data 1 for Input 3							
+5	Temperature Data 1 for Input 3							
+6	Temperature Data 1 for Input 3							
+7	Temperature Data 1 for Input 3							
+8	0	0	0	0	V_ST3	V_ST2	V_ST1	V_ST0
+9	0	0	0	0	T_ST3	T_ST2	T_ST1	T_ST0
+10	CCB	0	MRF	CCW	RHW	NPW	0	0

The following format is used when this data pattern is allocated starting from the rightmost byte of the Master.

Word	15	8	7	0
+0	Temperature Data 1 for Input 0			
+1	Temperature Data 1 for Input 1			
+2	Temperature Data 1 for Input 2			
+3	Temperature Data 1 for Input 3			
+4		Top Detection Timing Flags		Valley Detection Timing Flags
+5	Generic Status Flags			

**1/100 Display (Instance 188)**

	Bit 7	Bit 6	Bit 5	Bit 4	Bit 3	Bit 2	Bit 1	Bit 0
+0	Temperature Data 1 for Input 0							
+1	Temperature Data 1 for Input 0							
+2	Temperature Data 1 for Input 0							
+3	Temperature Data 1 for Input 0							
+4	Temperature Data 1 for Input 1							
+5	Temperature Data 1 for Input 1							
+6	Temperature Data 1 for Input 1							
+7	Temperature Data 1 for Input 1							
+8	Temperature Data 1 for Input 2							
+9	Temperature Data 1 for Input 2							
+10	Temperature Data 1 for Input 2							
+11	Temperature Data 1 for Input 2							
+12	Temperature Data 1 for Input 3							
+13	Temperature Data 1 for Input 3							
+14	Temperature Data 1 for Input 3							
+15	Temperature Data 1 for Input 3							
+16	0	0	0	0	V_ST3	V_ST2	V_ST1	V_ST0
+17	0	0	0	0	T_ST3	T_ST2	T_ST1	T_ST0
+18	CCB	0	MRF	CCW	RHW	NPW	0	0

The following format is used when this data pattern is allocated, starting from the rightmost byte of the Master.

<b>Word</b>	<b>15</b>	<b>8</b>	<b>7</b>	<b>0</b>
+0	Temperature Data 1 for Input 0			
+1	Temperature Data 1 for Input 0			
+2	Temperature Data 1 for Input 1			
+3	Temperature Data 1 for Input 1			
+4	Temperature Data 1 for Input 2			
+5	Temperature Data 1 for Input 2			
+6	Temperature Data 1 for Input 3			
+7	Temperature Data 1 for Input 3			
+8		Top Detection Timing Flags		Valley Detection Timing Flags
+9	Generic Status Flags			

**Hold Flags (Output)  
(Instance 190)**

Hold Flags are used with the peak/bottom hold and top/valley hold functions. The Hold Flags are used to control the hold execution timing from the Master and are allocated in the Master using the following data format (1 byte).

**Note** A delay may occur between when the Master’s power is turned ON until notification of the Hold Flag status is sent to the Slave.

	<b>Bit 7</b>	<b>Bit 6</b>	<b>Bit 5</b>	<b>Bit 4</b>	<b>Bit 3</b>	<b>Bit 2</b>	<b>Bit 1</b>	<b>Bit 0</b>
+0					<b>HD3</b>	<b>HD2</b>	<b>HD1</b>	<b>HD0</b>

The details for each bit are shown in the following table.

Bit	Abbreviation	Name	Details
<b>0</b>	<b>HD0</b>	Hold Flag for Input 0	The hold function is performed for Temperature Input 0 while this flag is ON. The hold function stops and the last value is held when the flag goes OFF.
<b>1</b>	<b>HD1</b>	Hold Flag for Input 1	The hold function is performed for Temperature Input 1 while this flag is ON. The hold function stops and the last value is held when the flag goes OFF.
<b>2</b>	<b>HD2</b>	Hold Flag for Input 2	The hold function is performed for Temperature Input 2 while this flag is ON. The hold function stops and the last value is held when the flag goes OFF.
<b>3</b>	<b>HD3</b>	Hold Flag for Input 3	The hold function is performed for Temperature Input 3 while this flag is ON. The hold function stops and the last value is held when the flag goes OFF.

The following format is used when the Hold Flags are allocated, starting from the rightmost byte of the Master.

<b>Word</b>	<b>15</b>	<b>8</b>	<b>7</b>	<b>0</b>
+0				<b>Hold Flags</b>

### 7-6-4 Functions and Settings

#### Moving Average Processing

This function calculates the average value (moving average) of the previous eight inputs, and uses the resulting value as conversion data. When the input value fluctuates frequently, averaging can be used to produce a stable input value, as shown in the following diagram.

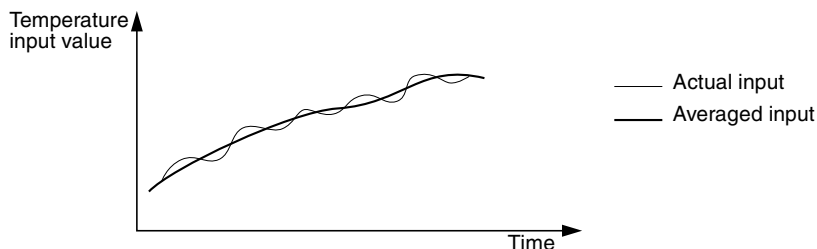

#### Setting Using the DeviceNet Configurator

- 1,2,3... 1. Double-click the icon of the Temperature Input Terminal to be set in the Main Window and open the Edit Device Parameters Window. (From the Maintenance Mode Window, click the right mouse button over the Slave icon and select **Parameters** and **Edit**.)
2. Select the Tab Page for the input where moving average processing is to be performed, and select **Moving Average** under the *Function Choice* heading.

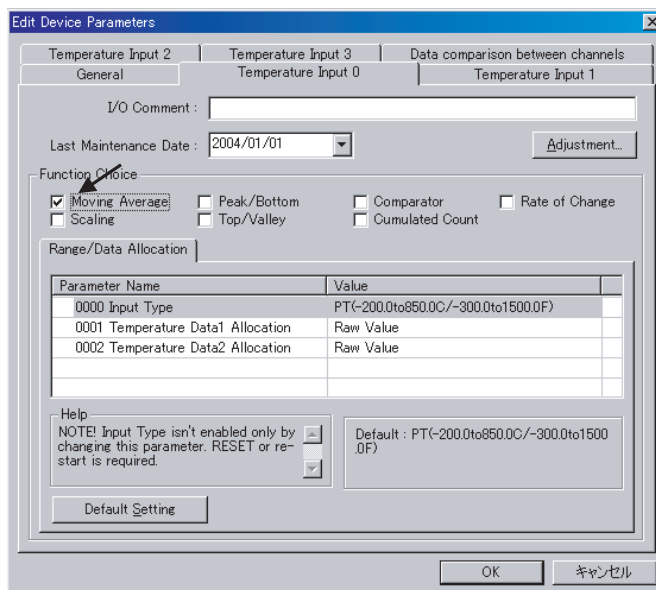

3. Return to the **General** Tab, click the **Download** Button, and then click the **Reset** Button to reset the Unit.
4. Click the **OK** Button and exit the window.

#### Scaling

Scaling can be used to convert the temperature input values (measured values) to display values in the scale required by the user. Scaling also eliminates the need for ladder programming in the Master to perform these basic math operations.

In order to scale the temperature input values (measured values) to the scale required by the user, use the Configurator to set the conversion values

(-28,000 to 28,000) for two points in the scale (the 100% value and 0% value).

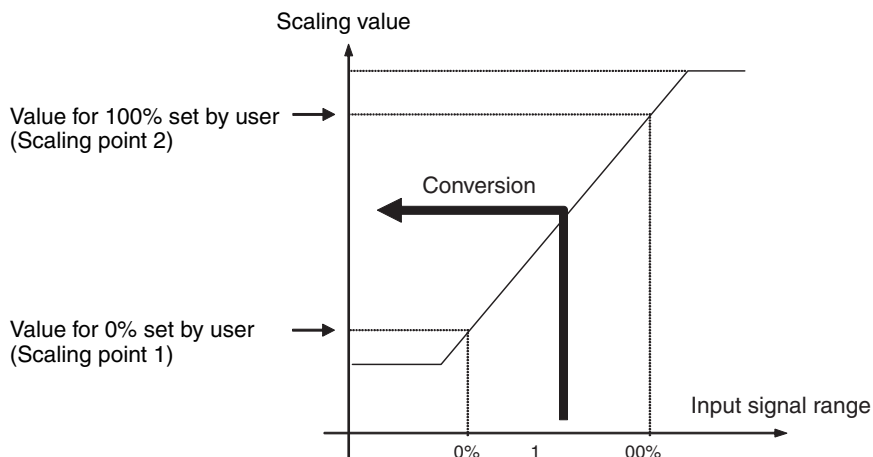

- Note**
1. The default values are 0 and 28,000.
  2. Reverse scaling, where the 0% scaling value is higher than the 100% scaling value, is also supported.

**Offset Compensation**

The scaling function is equipped with offset compensation, which can compensate for any error that occurs during scaling. The offset amount is added to the scaled line as shown in the following diagram. The offset (error) value can be input between -28,000 to 28,000, but make sure that underflow or overflow does not occur. The High Limit is 7FFE hex and the Low Limit is 8000 hex.

**Note** The offset value can be set even when using default scaling.

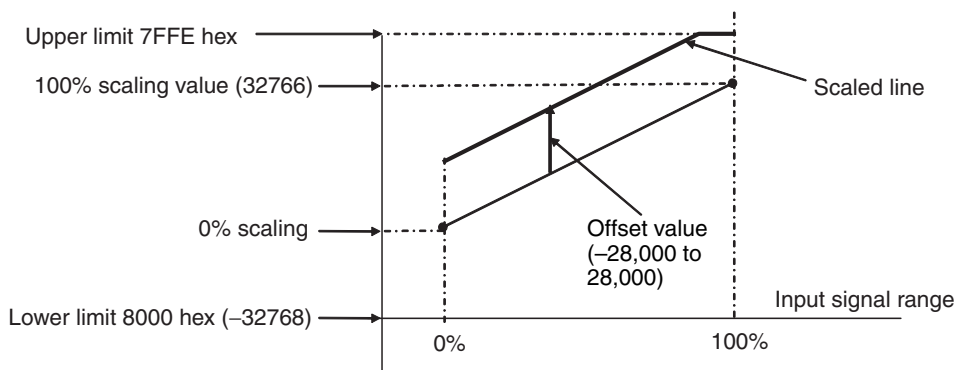

**Setting Using the DeviceNet Configurator**

- 1,2,3...**
1. Double-click the icon of the Temperature Input Terminal to be set in the Main Window and open the Edit Device Parameters Window. (From the Maintenance Mode Window, click the right mouse button over the Slave icon and select **Parameters** and **Edit**.)



- Select the Tab Page for the input where scaling is to be performed, and select **Scaling** under the *Function Choice* heading.

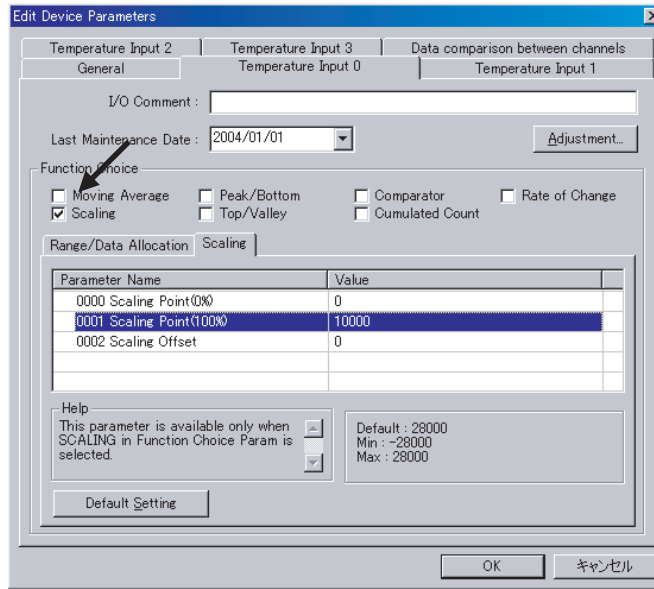

- Set the 0% value in the *Scaling point 1* field, and set the 100% value in the *Scaling point 2* field.

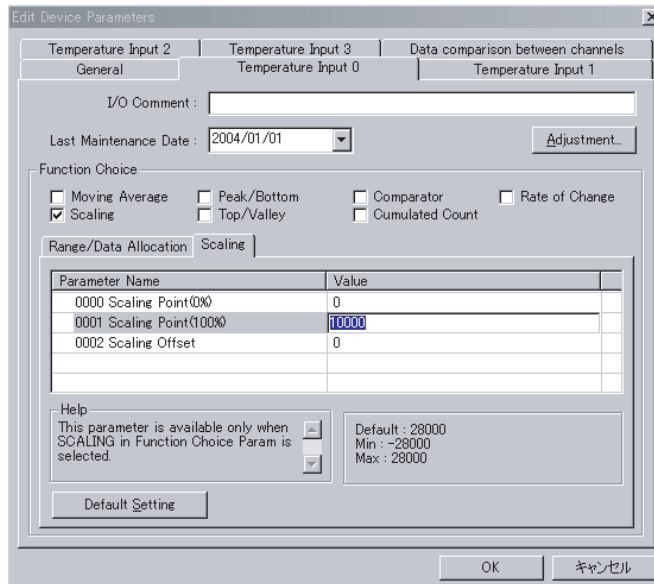

- When using the offset compensation option, set the offset value in the *Scaling Offset* field.

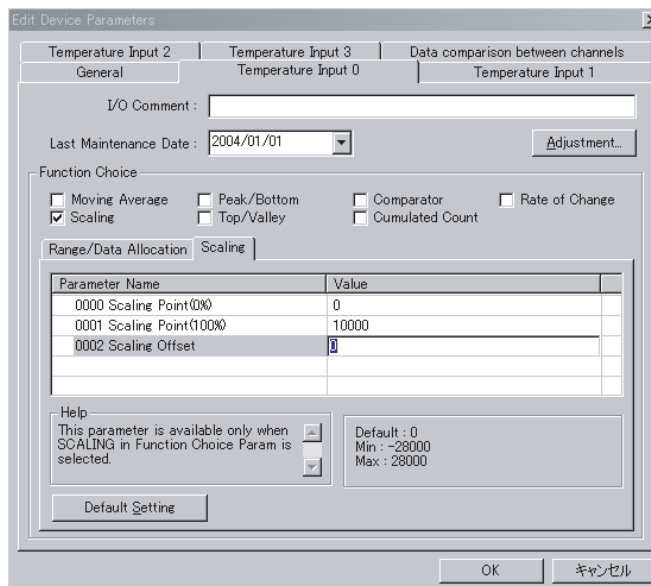

- Return to the **General** Tab, click the **Download** Button, and then click the **Reset** Button to reset the Unit.
- Click the **OK** Button and exit the window.

### Peak/Bottom Hold

Peak/bottom hold is used to hold the maximum (peak) value or minimum (bottom) value of the temperature input value. When the Hold Flag (output) allocated in the OUT Area turns ON, the hold function starts, searching for the peak or bottom value until the Hold Flag turns OFF. (The peak/bottom value is refreshed when the Hold Flag turns OFF.) The comparator function can be used to compare the peak or bottom values allocated as temperature data 1. (Refer to details on the comparator function.)

#### Example of Bottom Hold

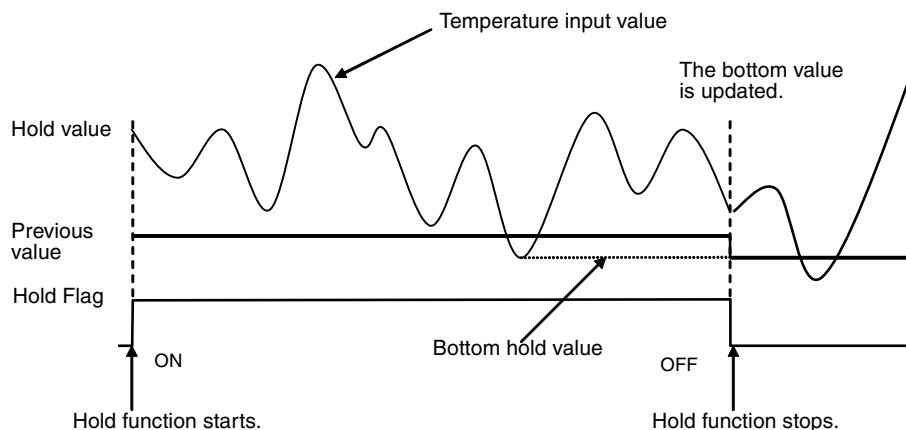

**Note** A delay in network transmission time will occur from the time the Hold Flag turns ON (or OFF) in the Master's ladder program until notification of the flag's status is actually sent to the Slave. Therefore, even when the Hold Flag is ON, the first temperature data transmitted to the Master when the CPU Unit power is turned ON may be the data from when the Hold Flag was OFF. To collect peak/bottom hold data using the Hold Flag at the Master, configure a ladder

program that considers the transmission delay when the Hold Flag is turned ON, then enables the peak/bottom hold values after a fixed time interval.

**Setting Using the DeviceNet Configurator**

- 1,2,3... 1. Double-click the icon of the Temperature Input Terminal to be set in the Main Window and open the Edit Device Parameters Window. (From the Maintenance Mode Window, click the right mouse button over the Slave icon and select **Parameters** and **Edit**.)
2. Select the Tab Page for the input where peak/bottom hold is to be set, and select **Peak/Bottom Hold** under the **Function Choice** heading.

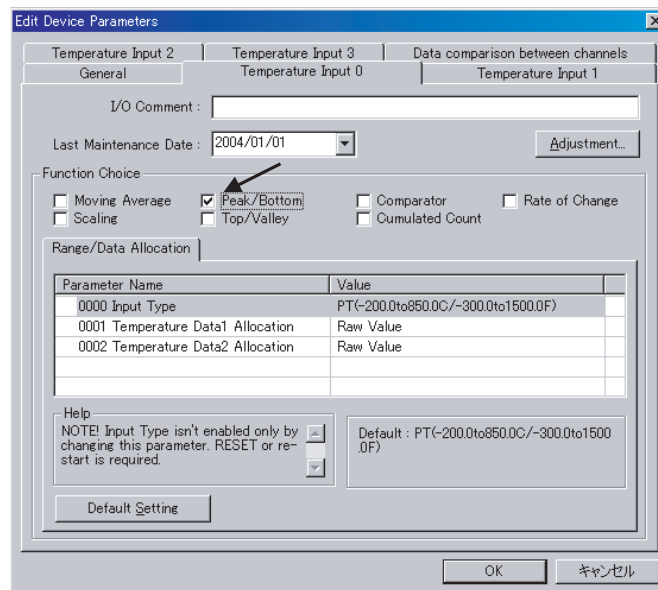

3. To allocate the Hold Flags (output) in the default connection path, click the **General** Tab and select **Holding Value** from the pull-down menu in the **Default Connection Path (Out)** field.

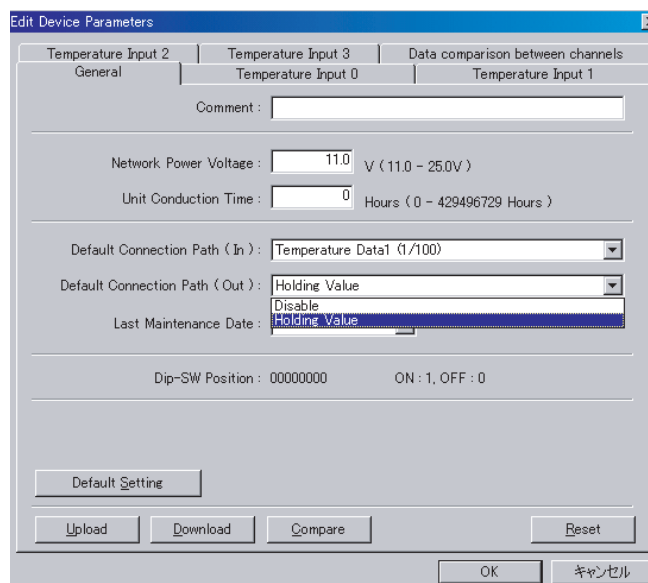

4. Click the **Download** Button and then click the **Reset** Button to reset the Unit.
5. Click the **OK** Button and exit the window.

**Top/Valley Hold**

Top/valley hold is used to hold the top and valley values of the temperature input value.

Temperature values that fluctuate more than twice the hysteresis value are monitored, and the top or valley values are held. The top or valley value is allocated along with the Top/Valley Detection Timing Flags, which can be used to check the hold timing.

When the Hold Flag (output) allocated in the OUT Area turns ON, the hold function starts, refreshing the top or valley value until the Hold Flag turns OFF. (The last value is held when the Hold Flag turns OFF, but the next time the Hold Flag turns ON, the hold value is initialized as soon as a top or valley occurs.) The comparator can be used to compare the top or valley value allocated as temperature data 1. (Refer to details on the comparator function.)

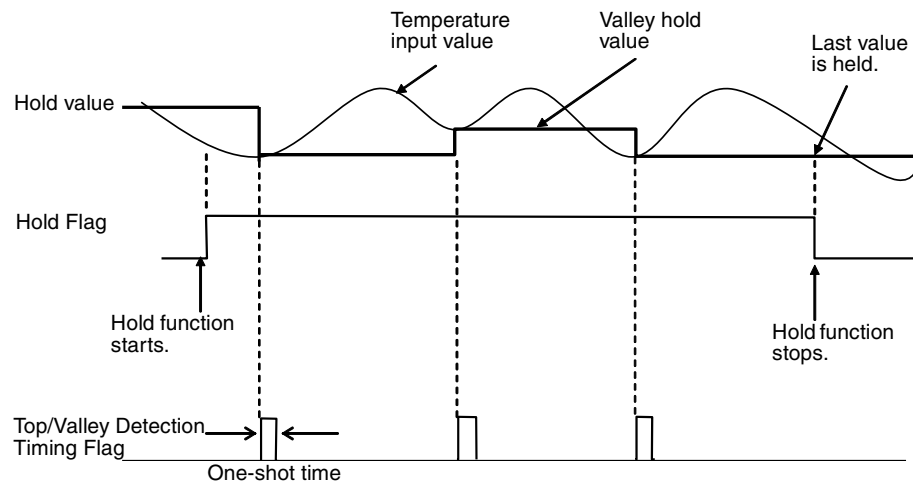
**Example of Valley Hold**

- Note**
1. A delay in network transmission time will occur from the time the Hold Flag turns ON (or OFF) in the Master's ladder program until notification of the flag's status is actually sent to the Slave. Therefore, even when the Hold Flag is ON, the first temperature data transmitted to the Master when the CPU Unit power is turned ON may be the data from when the Hold Flag was OFF. To collect top/valley hold data using the Hold Flag at the Master, configure a ladder program which considers the transmission delay time when the Hold Flag is turned ON, then enables the top/valley hold values after a fixed time interval.
  2. The time that the Top/Valley Detection Timing Flags are ON can be adjusted by setting the one-shot time. Use the Configurator to set the one-shot time (the setting range is 1 to 65,535 ms).
  3. If the Hold Flag turns OFF during the time the Top/Valley Detection Timing Flag is set to be ON, both flags will turn OFF simultaneously.

**Setting Using the DeviceNet Configurator**

- 1,2,3...**
1. Double-click the icon of the Temperature Input Terminal to be set in the Main Window and open the Edit Device Parameters Window. (From the Maintenance Mode Window, click the right mouse button over the Slave icon and select **Parameters** and **Edit**.)

2. Select the Tab Page for the input where top/valley hold is to be set, and select **Top/Valley** under the *Function Choice* heading.

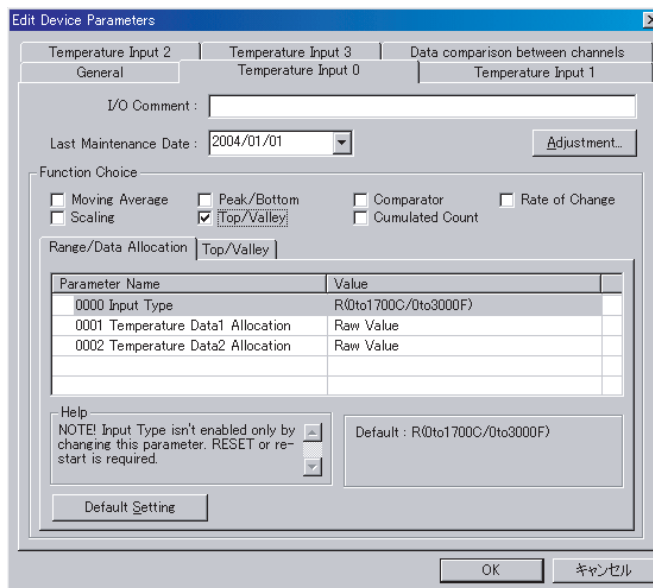

3. To allocate the Hold Flag (output) in the default connection path, click the **General** Tab, and select **Holding Value** from the pull-down menu in the *Default Connection Path (Out)* field.

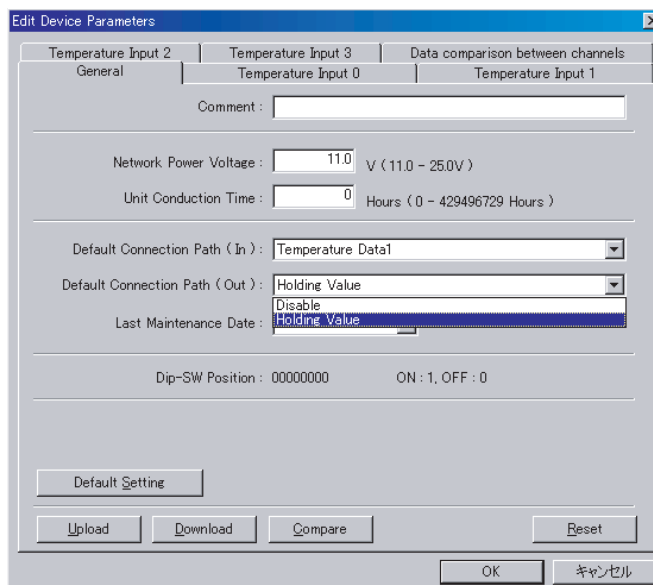

4. Click the **Download** Button, and then click the **Reset** Button to reset the Unit.

**Hysteresis Setting**

The hysteresis value can be set using the Configurator to prevent detection of top or valley values that occur due to minor fluctuations in the temperature input value. This will cause the start of data holding to be delayed after the actual top or valley value occurs, as shown in the following diagram.

**Timing for Setting Data**

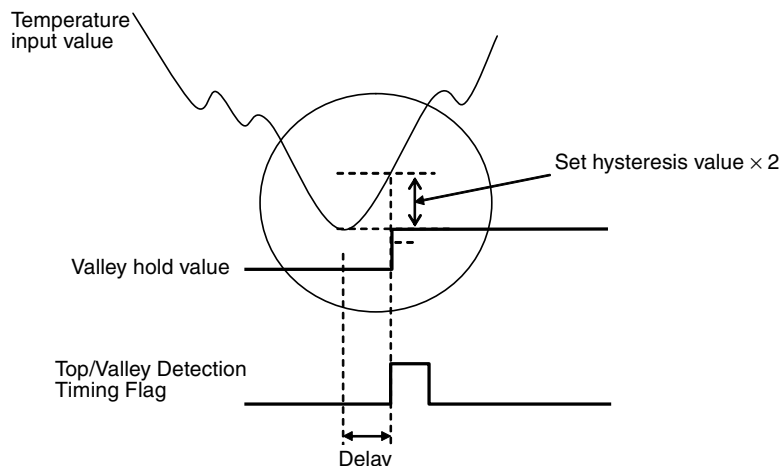

**Setting Hysteresis Using the DeviceNet Configurator**

- 1,2,3... 1. Input the value for hysteresis in the *Hysteresis* field in the **Top/Valley** Tab under the *Function Choice* heading.

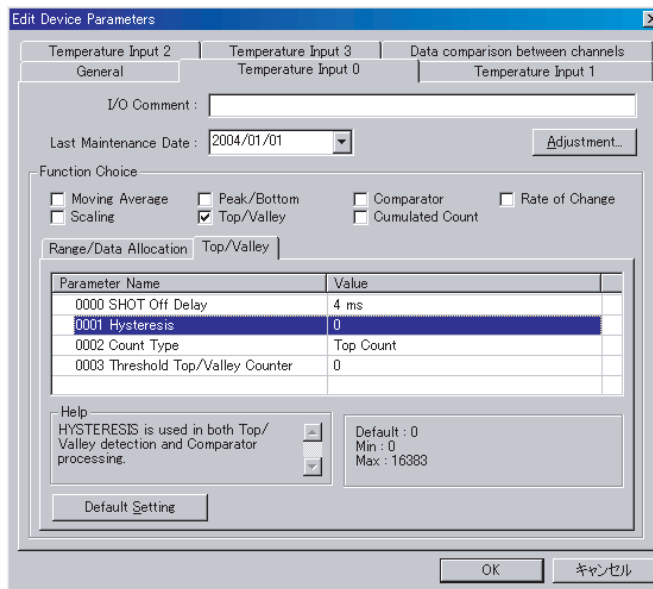

2. Return to the **General** Tab, click the **Download** Button, and then click the **Reset** Button to reset the Unit.  
 3. Click the **OK** Button and exit the window.

**Note** The hysteresis value set for the top/valley hold function is also used by the comparator function.

One-shot Time Setting

- 1,2,3... 1. Input the desired value in the *SHOT Off Delay* field of the **Top/Valley** Tab under the *Function Choice* heading.

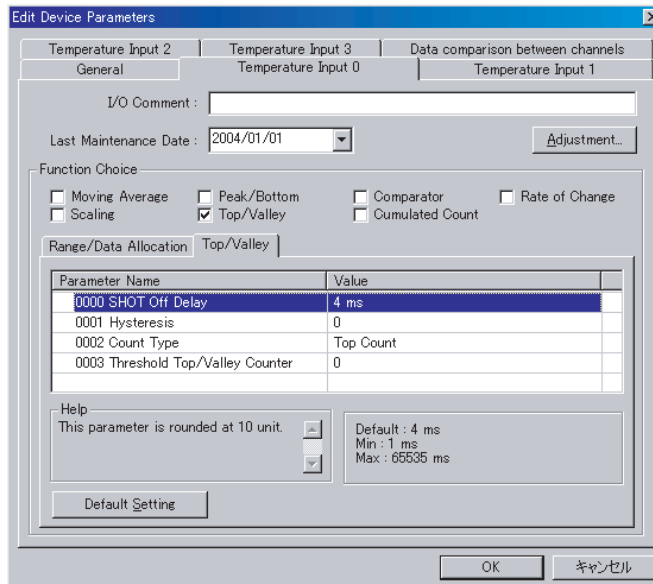

2. Return to the **General** Tab, click the **Download** Button, and then click the **Reset** Button to reset the Unit.  
 3. Click the **OK** Button and exit the window.

**Top/Valley Counter Function**

This function counts the number of temperature tops or valleys in devices or applications that have repetitive temperature rises (or drops). A threshold value can be set for the counter to indicate when preventative maintenance is required for the Unit or sensors.

The Over Threshold status can be read in the Maintenance Information Window or via an explicit message.

**Valley Counter Operation**

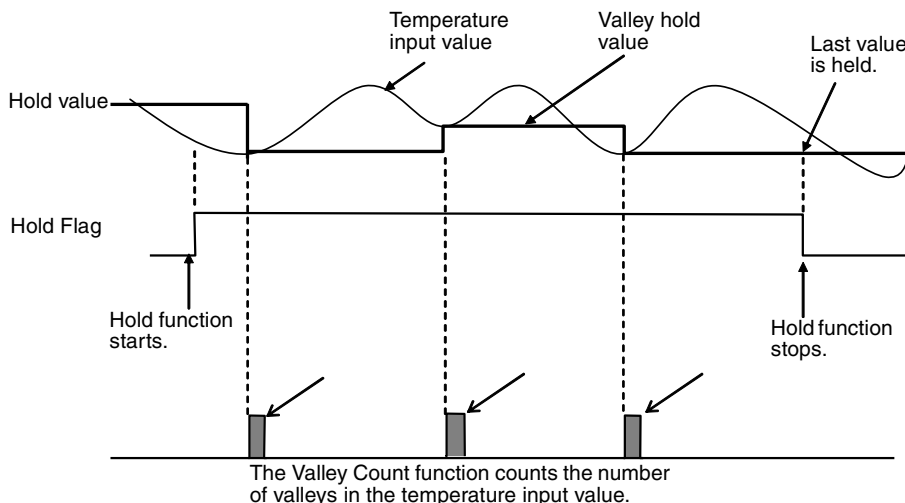

Setting Using the DeviceNet Configurator

- 1,2,3... 1. Double-click the icon of the Temperature Input Terminal to be set in the Main Window and open the Edit Device Parameters Window. (From the Maintenance Mode Window, click the right mouse button over the Slave icon and select **Parameters** and **Edit**.)
2. Select the Tab Page for the input where top/valley counter is to be set, and select **Top/Valley** under the *Function Choice* heading.
3. Select the **Top/Valley** Tab and select either **Top Count** or **Valley Count** from the pull-down menu in the *Count Type* field.

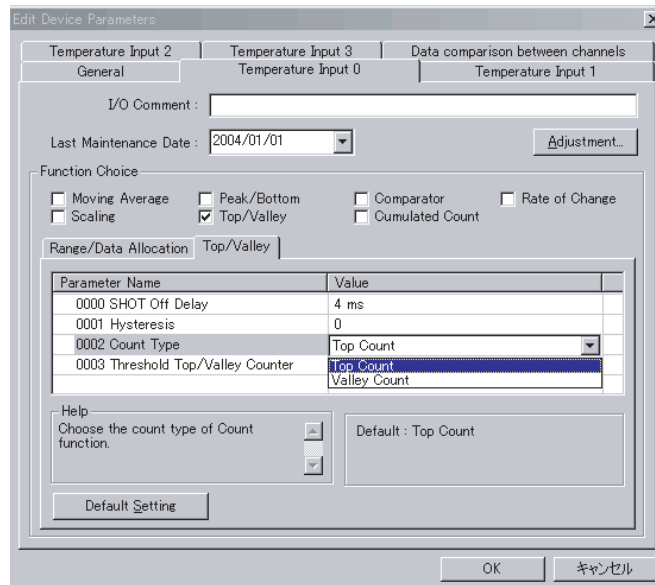

4. A threshold count value can be set in the *Threshold Top/Valley Counter* field.

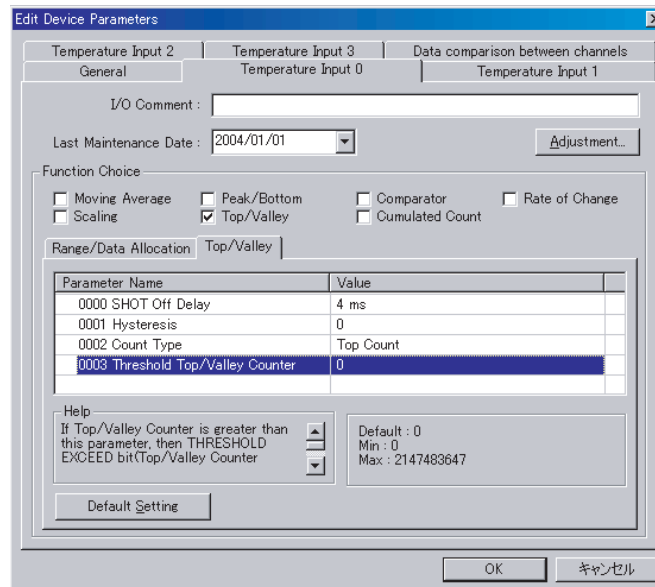

5. Return to the **General** Tab, click the **Download** Button, and then click the **Reset** Button to reset the Unit.
6. Click the **OK** Button and exit the window.



**Rate of Change Calculation**

The rate of change can be obtained for each sampling cycle set for the temperature input data. This function calculates the difference between each set sampling cycle and value obtained in the previous cycle. The sampling cycle can be set between 250 ms and 65,500 ms in 250-ms increments. The default setting for the sampling cycle is 250 ms.

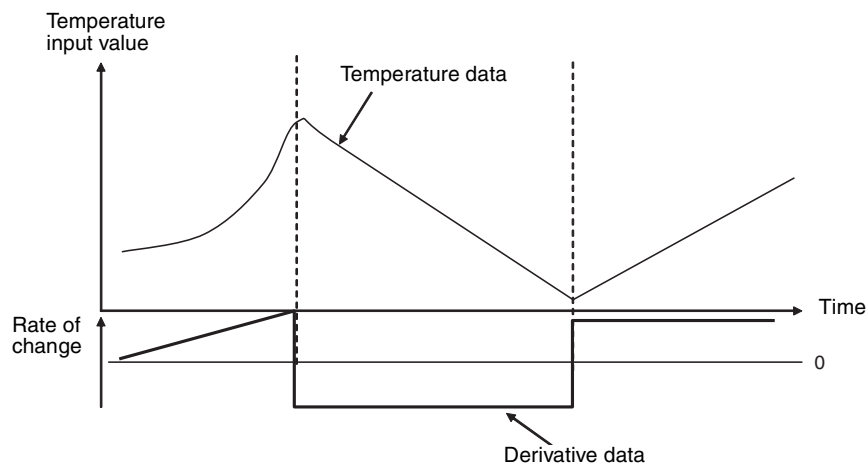

**Note** If the sampling cycle is set to a small value, the rate of change will be sensitive to small changes. If the temperature data is subject to minute fluctuations, and the sampling cycle is shorter than the cycle of fluctuation, the fluctuation will be regarded as the rate of change. To prevent this occurring, use moving average processing, which will set a longer sampling cycle.

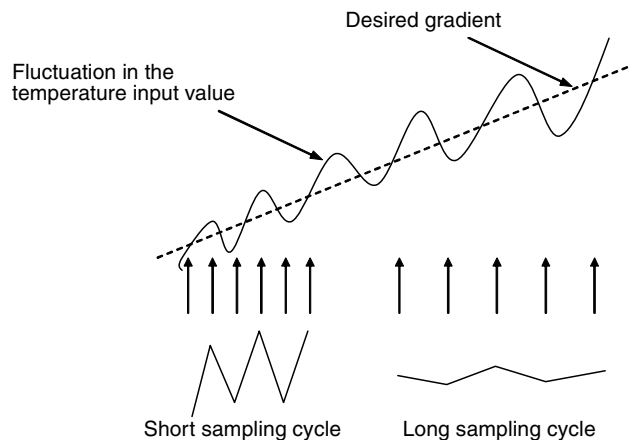

**Setting Using the DeviceNet Configurator**

- 1,2,3... 1. Double-click the icon of the Temperature Input Terminal to be set in the Main Window and open the Edit Device Parameters Window. (From the Maintenance Mode Window, click the right mouse button over the Slave icon and select **Parameters** and **Edit**.)

2. Select the Tab Page for the input where rate of change is to be set, and select **Rate of Change** under the *Function Choice* heading.

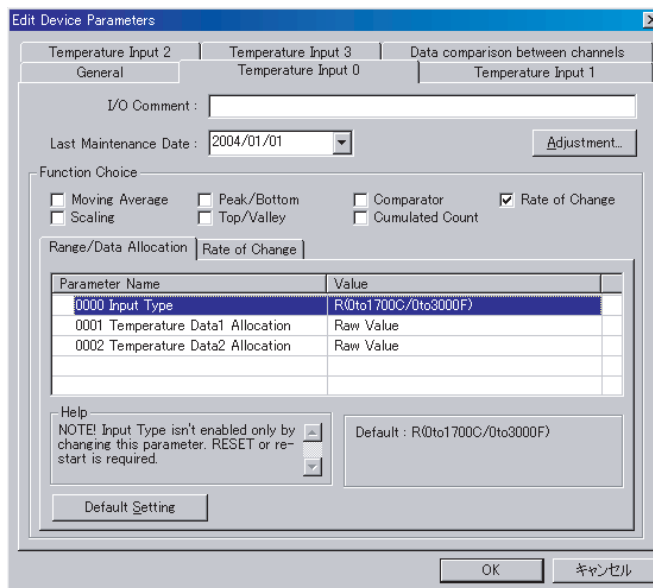

3. To set the sampling cycle, click the **Rate of Change** Tab and input the desired value for the sampling cycle in the *Sampling Rate* field.

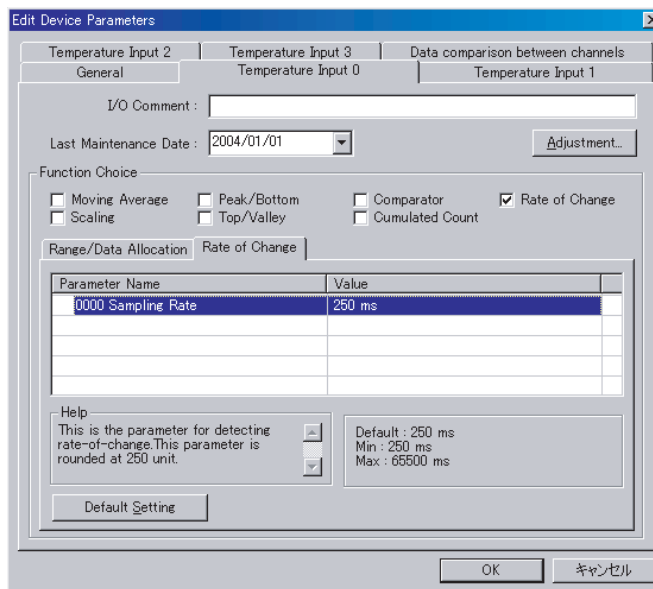

4. Return to the **General** Tab, click the **Download** Button, and then click the **Reset** Button to reset the Unit.
5. Click the **OK** Button and exit the window.

### Comparator

When the High High Limit, High Limit, Low Low Limit, and Low Limit are set in the Slave, a status flag will be turned ON when a value exceeds the setting range. The four set values are High High Limit (HH), High Limit (H), Low Low Limit (LL), and Low Limit (L), and the values are compared with those in Temperature Data 1. (The comparator function cannot be used with Temperature Data 2.)

The setting range is -31,500 to 415,000.

When each of these values is exceeded, the Comparator Result Flag in the area for Analog Status Flags is turned ON. If an alarm has not occurred, the Normal Flag (pass signal) will be ON.

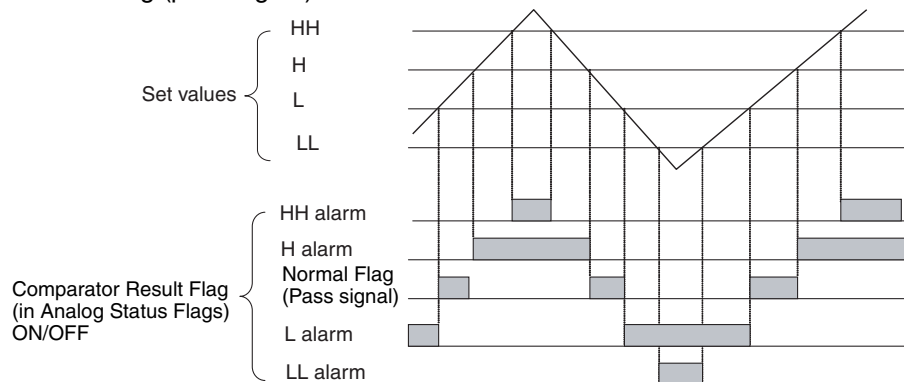

**Note** When the temperature input value changes faster than the conversion cycle, the status may go from a Low Limit alarm directly to a High Limit alarm without having the Normal Flag (pass signal) go ON in between. Configure ladder programs to prevent this from occurring.

**Setting Hysteresis**

The Comparator Result Flag turns OFF when the value is lower than the hysteresis width (H or HH alarm occurs) or exceeds it (L or LL alarm occurs), as shown in the following diagram. If the analog value fluctuates around the threshold, and the flag repeatedly turns ON or OFF, setting hysteresis will stabilize the flag operation. The setting range is 0 to 16,383.

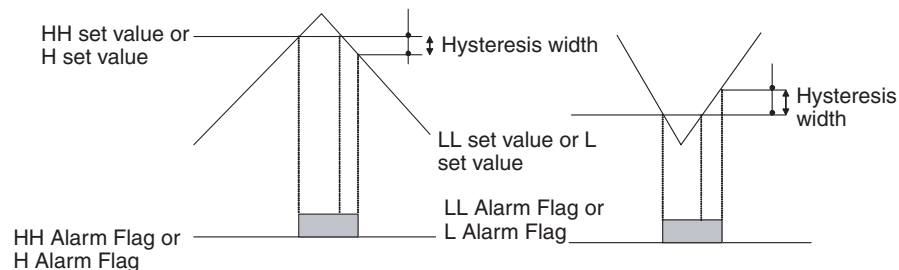

**Note** When setting the hysteresis value, adjust for each input's decimal point position or the 1/100 display mode if the 1/100 display mode is being used. Always correct the hysteresis value after changing the display mode setting or replacing the sensor with a sensor that has a different decimal point position. Example hysteresis value settings for 10°C:

- R thermocouple (normal display) setting: 0010 decimal
- T thermocouple (normal display) setting: 0100 decimal
- Setting for any input with 1/100 display: 1000 decimal

**OFF Delay**

The time until the Comparator Result Flag turns OFF can be extended. For example, even if the Flag is ON momentarily, the OFF delay can be set so that the Master can receive notification of the Flag's status.

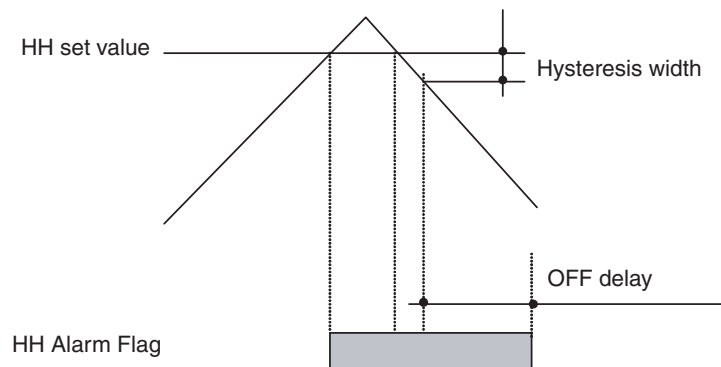

**Setting Using the DeviceNet Configurator**

- 1,2,3... 1. Double-click the icon of the Temperature Input Terminal to be set in the Main Window and open the Edit Device Parameters Window. (From the Maintenance Mode Window, click the right mouse button over the Slave icon and select **Parameters** and **Edit**.)
2. Select the Tab Page for the input where the comparator function is to be set, and select **Comparator** under the *Function Choice* heading.

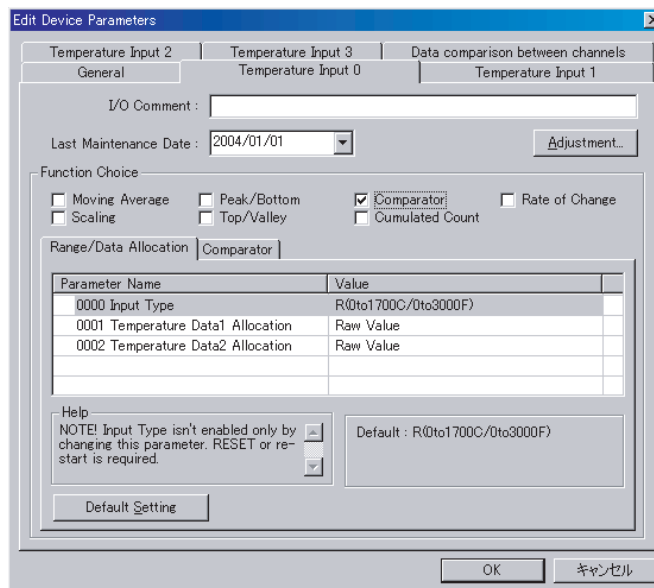

- Click the **Comparator** Tab and set each of the alarm values. The example here shows the setting for *Alarm Trip Point High* (HH limit set value).

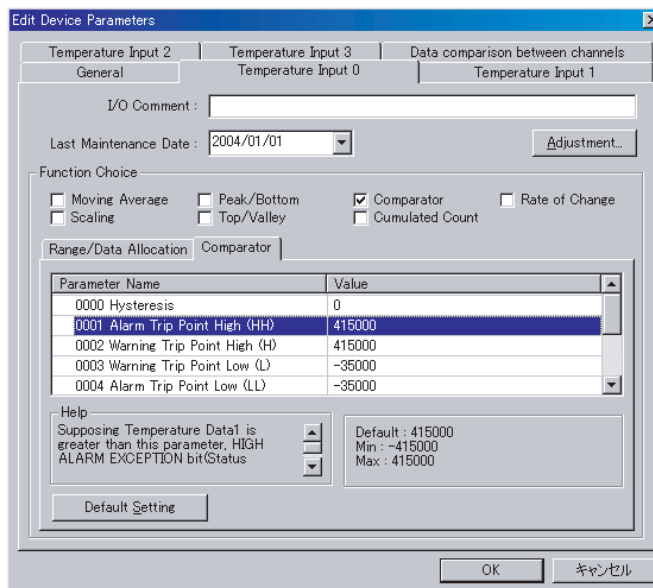

**Note** When setting the hysteresis value, adjust for each input's decimal point position or the 1/100 display mode if the 1/100 display mode is being used. Always correct the hysteresis value after changing the display mode setting or replacing the sensor with a sensor that has a different decimal point position.

Example hysteresis value settings for 10°C:

- R thermocouple (normal display) setting: 0010 decimal
  - T thermocouple (normal display) setting: 0100 decimal
  - Setting for any input with 1/100 display: 1000 decimal
- To set the hysteresis value, input the desired value in the *Hysteresis* field.

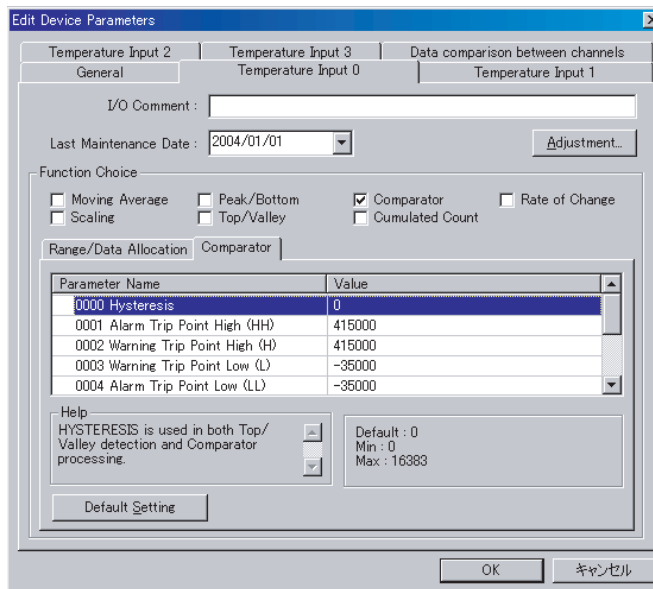

**Note** The hysteresis value set for the comparator function is also used by the top/valley hold function.

- To set the OFF delay function, input the desired value in the *Comparator Off Delay* field.

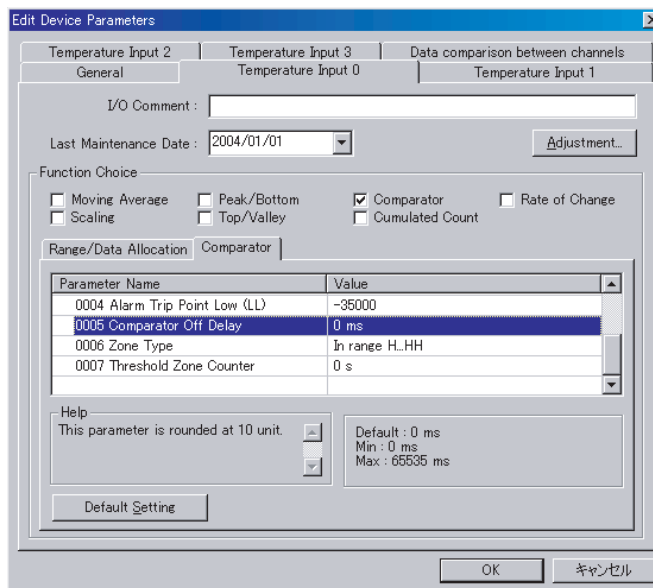

- Return to the **General** Tab, click the **Download** Button, and then click the **Reset** Button to reset the Unit.
- Click the **OK** Button and exit the window.

### Temperature Zone Counter Function (Zone Count)

This function times (in 1-second units) how long the temperature input value is within a user-set temperature range. The zone count can indicate when preventative maintenance is required for devices or applications that deteriorate at a fixed rate within the user-set temperature range.

Select the temperature zone settings in the **Comparator** Tab. The temperature zone boundaries are defined by the High High Limit (HH), High Limit (H), Low Low Limit (LL), or Low Limit (L). Any threshold value can be set in the Threshold Zone Counter to indicate when the threshold time within the zone has been exceeded.

The Over Threshold status can be read in the Maintenance Information Window or via an explicit message.

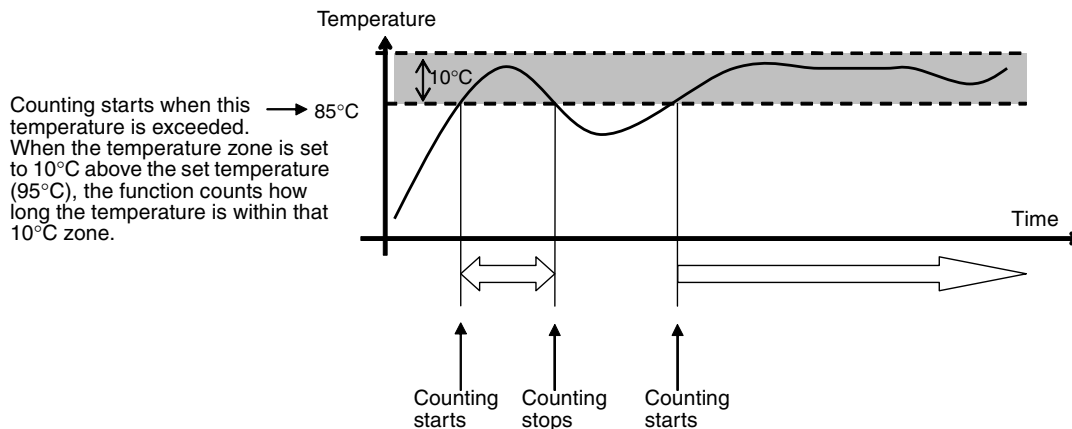

Setting Using the DeviceNet Configurator

- 1,2,3... 1. Double-click the icon of the Temperature Input Terminal to be set in the Main Window and open the Edit Device Parameters Window. (From the Maintenance Mode Window, click the right mouse button over the Slave icon and select **Parameters** and **Edit**.)
2. Select the Tab Page for the input where the Zone Count function is to be set, and select **Comparator** under the *Function Choice* heading.

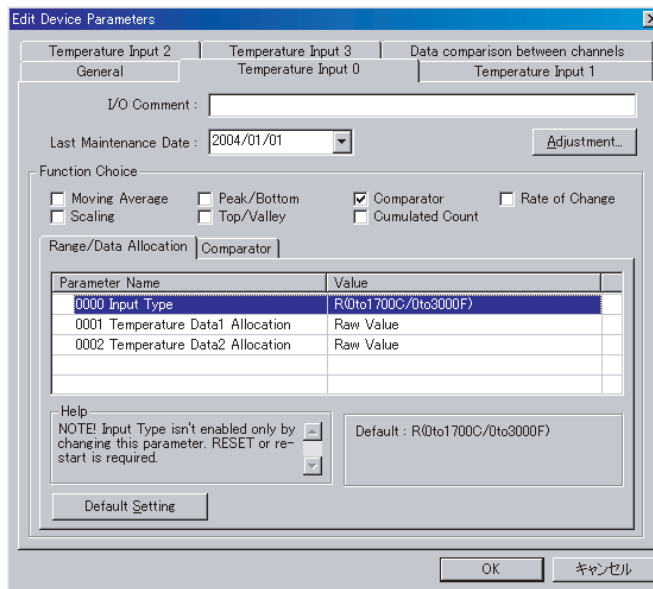

3. Click the **Comparator** Tab and select the desired type of zone from the pull-down menu under the *Zone Type* field.

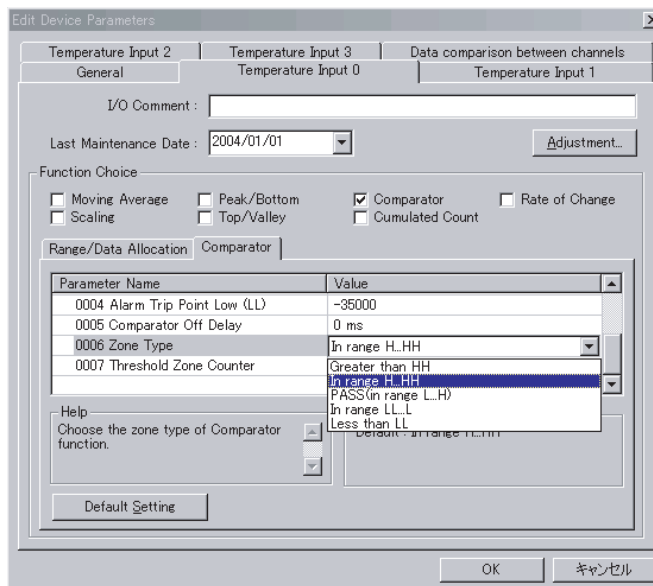

- A threshold count value (time in seconds) can be set in the *Threshold Zone Counter* field to indicate when the temperature has been in the temperature zone longer than the threshold setting.

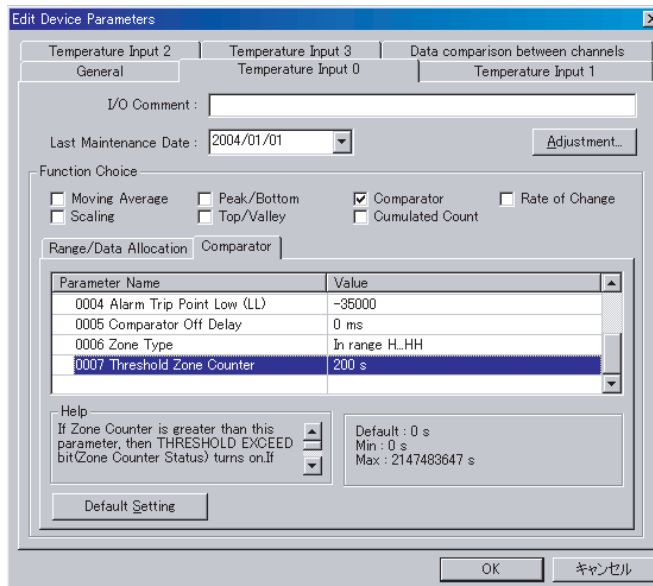

- Return to the **General** Tab, click the **Download** Button, and then click the **Reset** Button to reset the Unit.
- Click the **OK** Button and exit the window.

**Data Comparison between Channels**

This function can be used to compare the temperature values in any two inputs (inputs 0 to 3) and monitor the relative temperature difference. A threshold value can be set to detect an excessive temperature difference for preventative maintenance in devices in which the temperature difference may cause or indicate a problem.

The comparison result and over-threshold status can be read in the Maintenance Information Window or via an explicit message.

- Note**
- The comparison operation can be performed only on the data set as Temperature Data 2.
  - When the “peak value” or “bottom value” is selected as the temperature data for Temperature Data 2, that processed value will be used in the comparison operation and not the actual temperature input value.



- The comparison result will be read to a precision of 0.01, regardless of the setting.

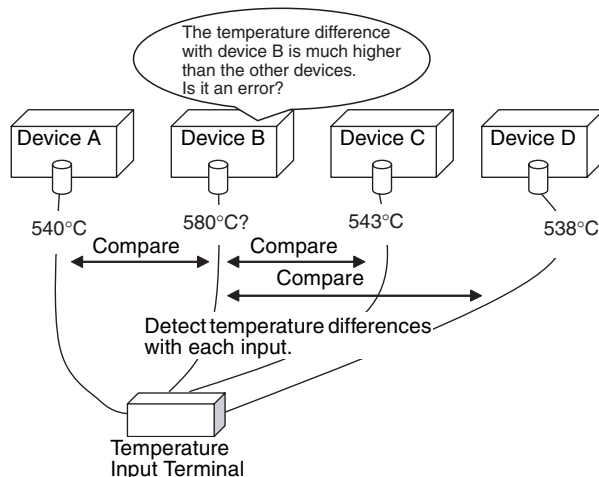

**Setting Using the DeviceNet Configurator**

- 1,2,3... 1. Double-click the icon of the Temperature Input Terminal to be set in the Main Window and open the Edit Device Parameters Window. (From the Maintenance Mode Window, click the right mouse button over the Slave icon and select **Parameters** and **Edit**.)
2. Select the **Data comparison between channels** Tab.

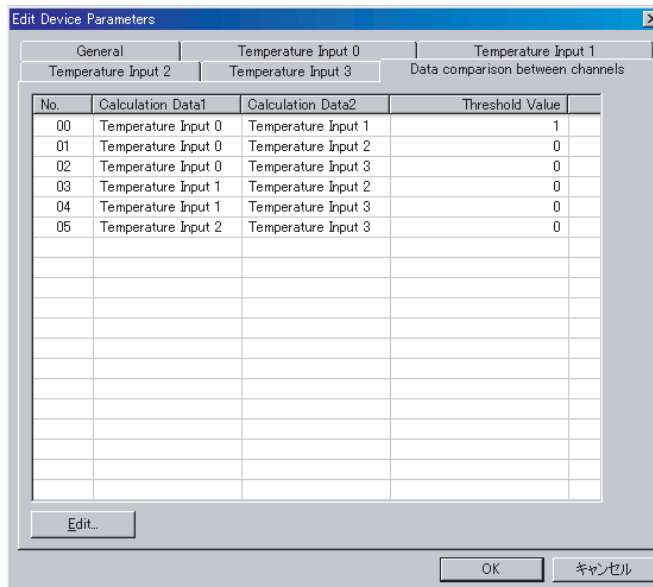

3. Double-click the **Calculation Data1** or **Calculation Data2** header cell to open the Edit Calculation Data Window. Select the two temperature inputs (to be compared) from the pull-down menus in the *Calculation Data1* and *Calculation Data2* fields. Set a threshold value in the *Threshold Value* field. Always set the threshold

value to a precision of 0.01. For example, when setting 10°C, input 1000 for 10.00°C.

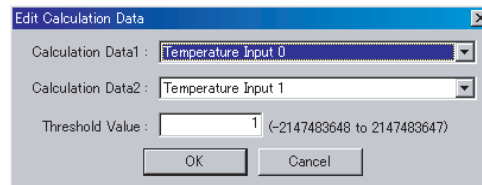

4. Return to the **General** Tab, click the **Download** Button, and then click the **Reset** Button to reset the Unit.
5. Click the **OK** Button and exit the window.
6. The comparison results can be checked in the Maintenance Information Window or **Data comparison between channels** Tab.

### **Off-wire Detection**

When an input sensor is disconnected, the Off-wire Detection Flag turns ON for each input. The Off-wire Detection Flags are included in the Analog Status Flags.

When an off-wire condition is detected, the value of AD conversion data is set to 7FFF hex (7FFF FFFF when 1/100 display mode is being used). When the input returns to a value within the range that can be converted, the Off-wire Detection function will automatically be turned OFF, and normal data conversion will resume.

### **Last Maintenance Date**

The last maintenance date can be set in the Unit separately for the Unit and the connected devices. It enables the user to easily determine the next maintenance date. The date can be set using the Configurator.

### **Setting Using the DeviceNet Configurator**

#### ■ **Setting the Last Maintenance Date of the Unit**

- 1,2,3... 1. Double-click the icon of the Temperature Input Terminal to be set in the Main Window and open the Edit Device Parameters Window. (From the Maintenance Mode Window, click the right mouse button over the Slave icon and select **Parameters** and **Edit**.)

- Click the **General** Tab, and select the applicable date from the pull-down menu in the *Last Maintenance Date* field. (To enter the current date, select **Today**, which is at the bottom of the pull-down menu.)

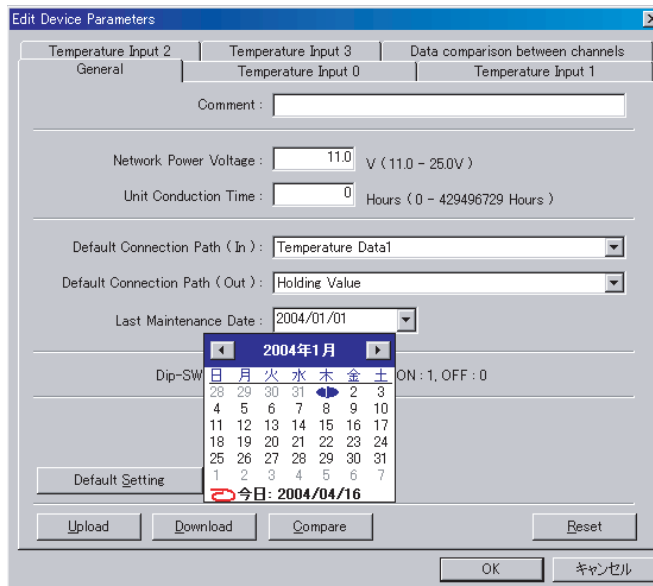

- Click the **Download** Button, and then click the **Reset** Button to reset the Unit.
- Click the **OK** Button and exit the window.

■ **Setting the Last Maintenance Date of the Connected Device**

1,2,3...

- Double-click the icon of the Temperature Input Terminal to be set in the Main Window and open the Edit Device Parameters Window. (From the Maintenance Mode Window, click the right mouse button over the Slave icon and select **Parameters** and **Edit**.)
- Click the Tab Page for the input that is connected to a connecting device requiring the last maintenance date to be set. Select the applicable date from the pull-down menu in the *Last Maintenance Date* field. (To enter the current date, select **Today**, which is at the bottom of the pull-down menu.)

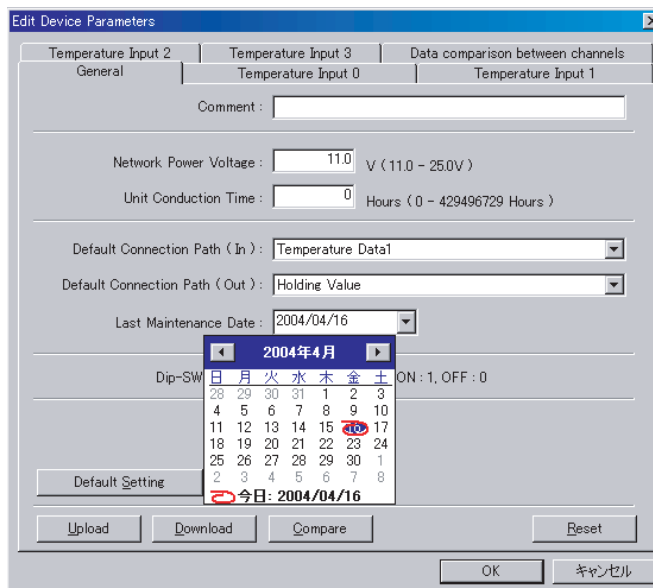

3. Return to the **General** Tab, click the **Download** Button, and then click the **Reset** Button to reset the Unit.
4. Click the **OK** Button and exit the window.

### Cumulative Counter

The cumulative counter integrates the temperature input value over time to determine the amount of heat endured by a sensor or device. calculates a time integral of analog input values over time. The cumulative value can be calculated in hours ( $^{\circ}\text{C} \times \text{hours}$  or  $^{\circ}\text{F} \times \text{hours}$ ) or minutes ( $^{\circ}\text{C} \times \text{minutes}$  or  $^{\circ}\text{F} \times \text{minutes}$ ).

For example, when the units are set to hours, a cumulative value of 100 hours indicates a temperature value equivalent to  $100^{\circ}\text{C}$  continuing for one hour. The value stored in the four-byte area (two words) is the integral value for 300 time divisions. The data is displayed according to the set conditions. (See notes 1 and 2.)

Monitor values can also be set in the Unit. When the cumulated count value exceeds the set monitor value, the Cumulative Counter Flag in the area for Generic Status Flags turns ON.

- Note**
1. When  $^{\circ}\text{F}$  units are selected, the integration is performed on the  $^{\circ}\text{F}$  values.
  2. Even if the 1/100 display mode is selected, the integration is performed on the original ( $\times 100$ ) temperature values.
  3. The meaning of the integral value depends on the decimal point position for the temperature values.

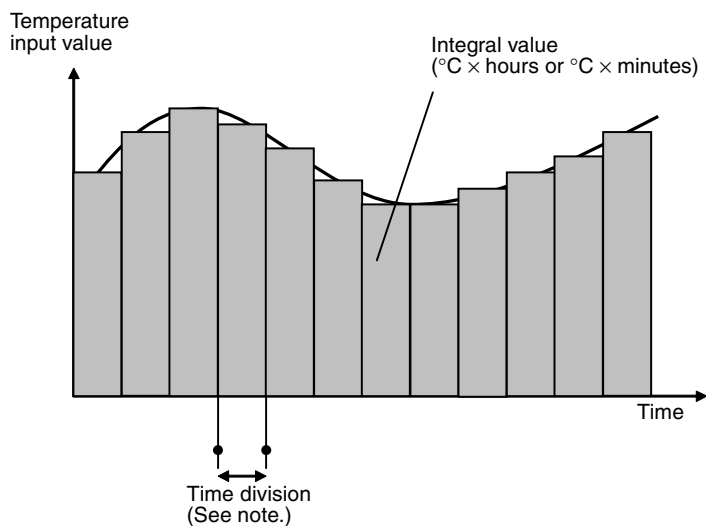

**Note** The following table shows the time divisions and number of measurements.

Units	Time division	Number of measurements
Hours	12 seconds	300
Minutes	200 ms	300

### Setting Using the DeviceNet Configurator

- 1,2,3...**
1. Double-click the icon of the Temperature Input Terminal to be set in the Main Window and open the Edit Device Parameters Window. (From the Maintenance Mode Window, click the right mouse button over the Slave icon and select **Parameters** and **Edit**.)

- Select the Tab Page for the input where the cumulative counter is to be set, and select **Cumulated Count** under the *Function Choice* heading.

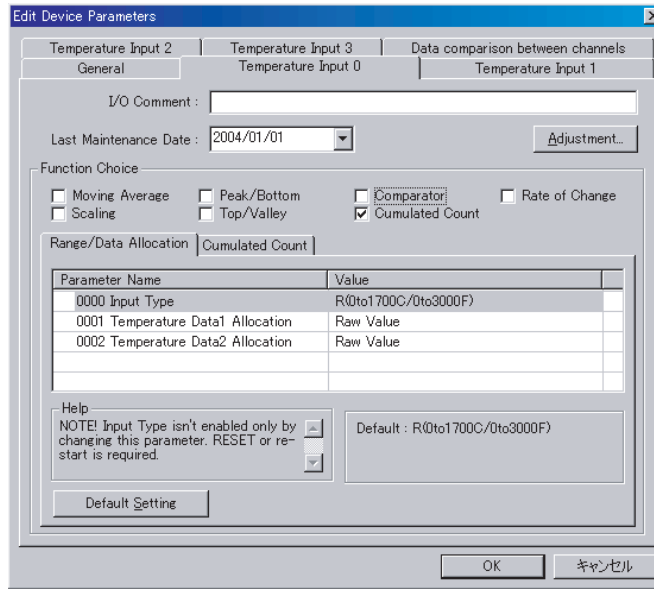

- To set the counter unit, click the **Cumulated Count** Tab and select **Hour** or **Minute** from the pull-down menu in the *Cumulated Timer* field.

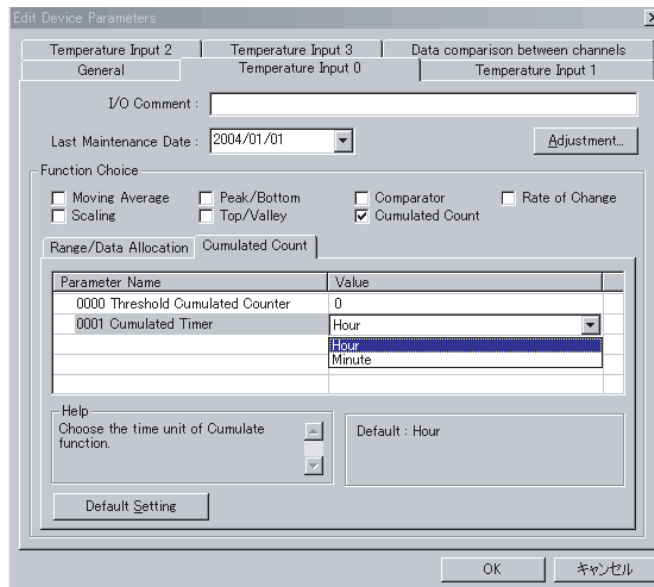

- To set the monitor value, click the **Cumulated Count** Tab, and input the desired value in the *Threshold Cumulated Counter* field.

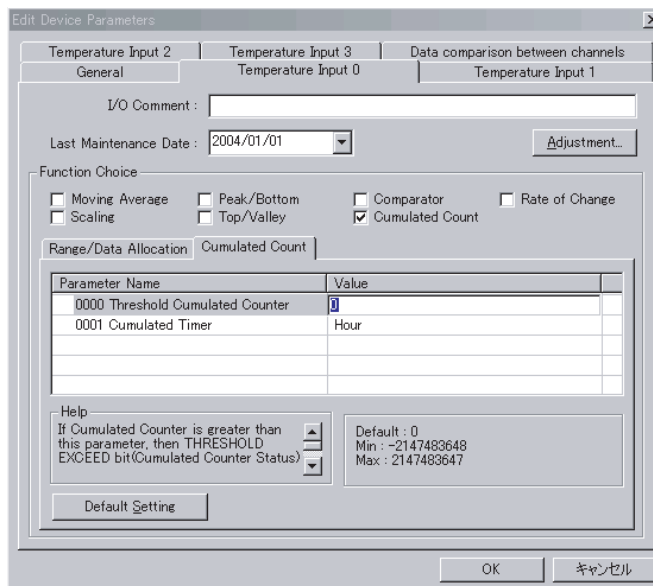

- Return to the **General** Tab, click the **Download** Button, and then click the **Reset** Button to reset the Unit.
- Click the **OK** Button and exit the window.

### User Adjustment

This function can be used to compensate for offsets in the input values caused by factors such as the characteristics and connection methods of the input sensor.

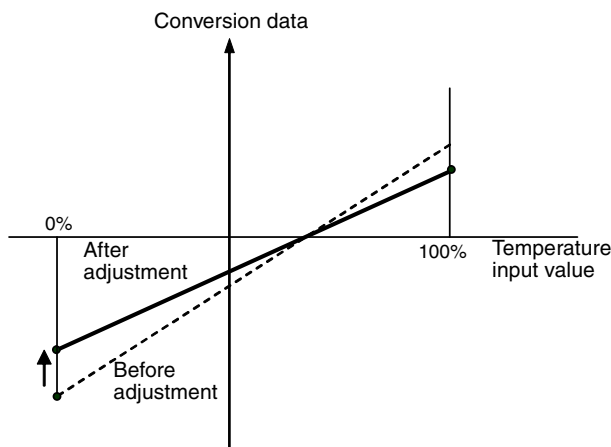

- Note**
- Temperature Input Terminals are properly adjusted at the factory before shipment, so it is normally unnecessary to make adjustments. Use the User Adjustment function only when absolutely necessary. OMRON is not responsible for the results of user adjustments. If a mistake is made in the adjustments, the adjustment data can be cleared to return to the factory default settings.
  - The Temperature Input Terminal continues the temperature conversion operations even after user adjustments have been made. It is possible for temperature data values to change suddenly from previous values after the user adjustments are made, so always consider the effects on the operating environment before applying user adjustments.

**Adjustment Procedure for the DRT2-TS04T**

Use the following procedure to adjust the Temperature Input Terminal. Follow the flowchart closely for proper adjustment.

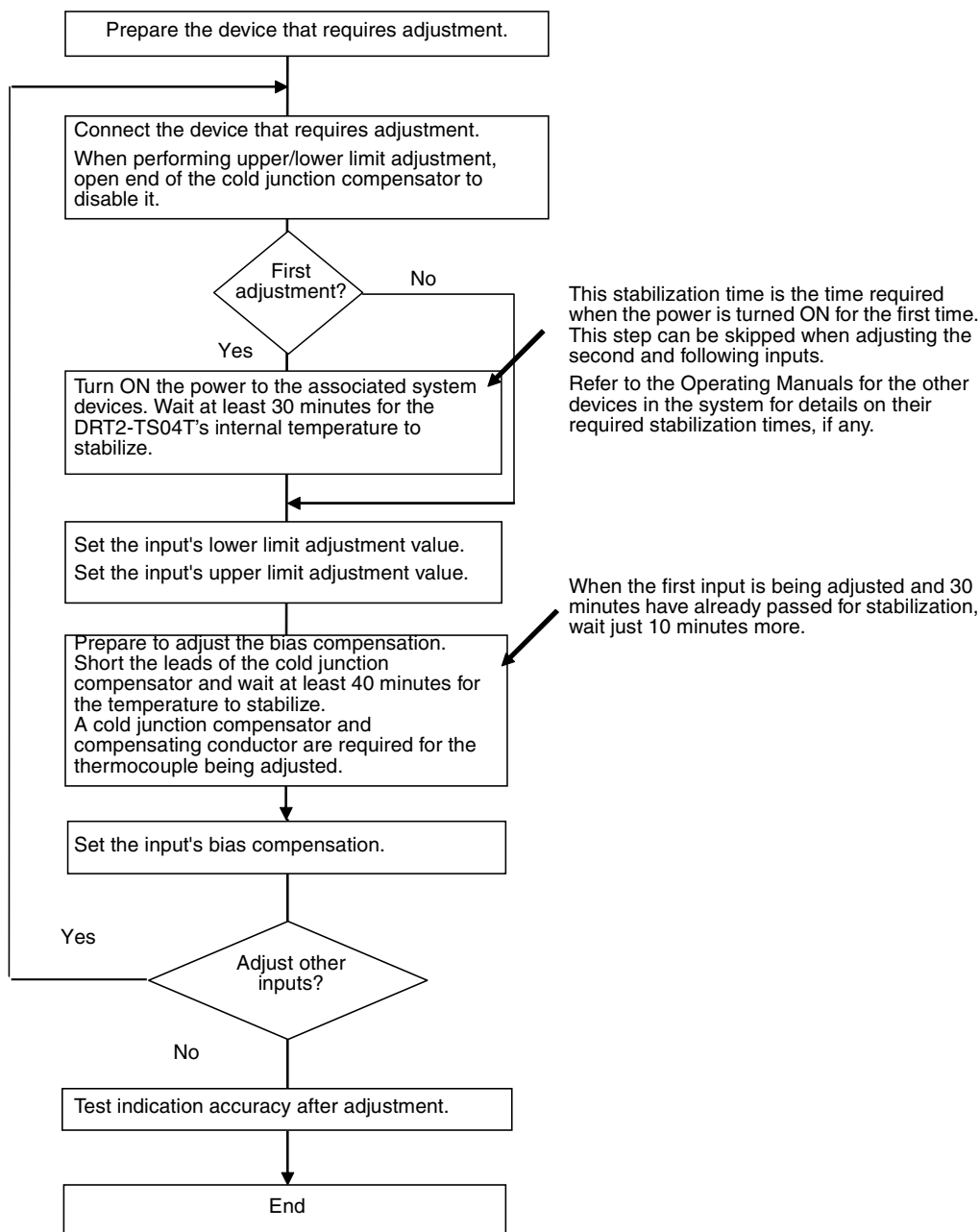

**Note** The only sensors that can be adjusted are ones that operate while the power supply is ON. When adjusting for sensors that are not presently in use, change the input type setting, toggle the power supply or reset the Unit from the Configurator, and perform the adjustment procedure from the beginning of the flowchart.

**Connecting the Devices required for DRT2-TS04T Adjustment**

The following paragraphs explain how to connect the devices that must be connected to the DRT2-TS04T for user adjustment. Wire the following devices properly when adjusting the DRT2-TS04T.

■ **Reference Voltage/Current Generator and Precision Digital Multimeter**

Used to make adjustments at the upper limit and lower limit.

Prepare devices that can generate accurate 0 mV, 20 mV, and 50 mV voltages. Use a precision digital multimeter that can measure the output voltage and indicate when the voltage/current generator is not producing an accurate voltage output.

■ **Cold Junction Compensator (such as a ZERO-CON 0°C Bath) and Compensating Conductors**

Used to adjust the bias compensation value.

The cold junction compensator (the ZERO-CON 0°C bath is used in following examples) is a device that maintains an accurate 0°C (32°F) temperature for thermocouple sensors. Use a cold junction compensator compatible with the sensor being adjusted.

**Note** When using an R, S, E, B, or W type thermocouple, a K type can be substituted. Set the ZERO-CON to 0°C (32°F).

■ **DeviceNet Configurator (Version 2.40 or Higher)**

The actual adjustment operations are performed with the Configurator. Check the version of the Configurator, because the DRT2-TS04T cannot be adjusted with an old version.

Refer to the DeviceNet Configurator Operation Manual for details on the Configurator.

**Adjustment Device Connection Diagram**

Connect the reference voltage/current generator (STV), precision digital multimeter (DMM), and cold junction compensator to the input terminals. In the following examples, the devices are connected to input 1, but connect to the corresponding terminals when adjusting inputs 2 to 4.

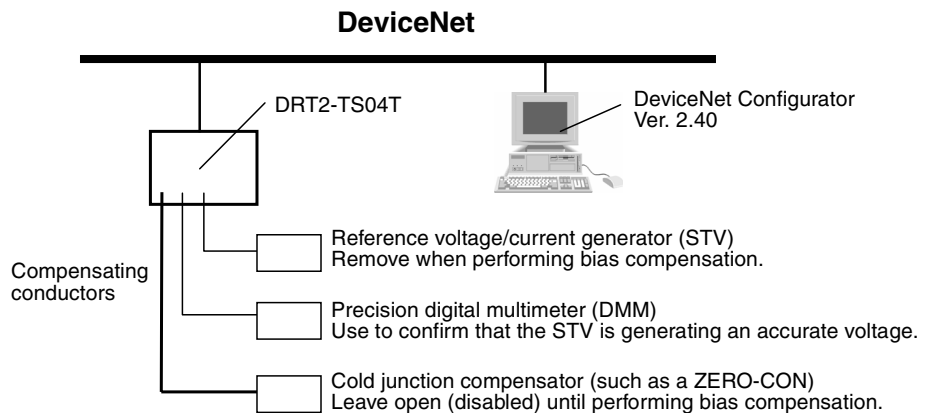

**Note** The personal computer (Configurator) is connected through DeviceNet in the diagram above. If a CS1W-DRM21 or CJ1W-DRM21 Master Unit is being used, the Configurator can also be connected through the Master Unit using a peripheral bus connection. Refer to the Configurator Operation Manual for details.

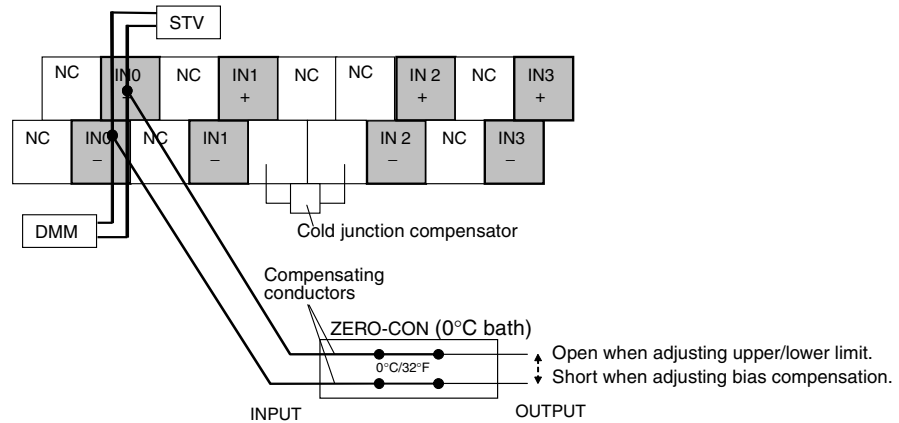

**Input Terminal Connections****Checking the Wiring and Making Adjustments****■ Adjusting the DRT2-TS04T's Upper and Lower Limit Values**

- 1,2,3...**
1. Open the thermocouple leads from the ZERO-CON (0°C bath).
  2. Check the sensor and input type being used.
 

**Note** When using an R, S, B, E, or W sensor, use a K thermocouple's compensating conductors. In addition, when using an R, S, or B type sensor, set the input type as K2 (0.0 to 500.0°C). When using an E or W type sensor, set the input type as K1 (-200 to 1,300°C).
  3. Connect the Configurator to the DeviceNet network and go online.
  4. Upload settings to the Configurator.
  5. Turn ON the power supplies of all Units, including the Temperature Input Terminal to be adjusted. Wait approximately 30 minutes for the Temperature Input Terminal's internal temperature to stabilize.
  6. Double-click the icon of the Temperature Input Terminal to be set in the Main Window and open the Edit Device Parameters Window. (From the Maintenance Mode Window, click the right mouse button over the Slave icon and select **Parameters** and **Edit**.)

7. Select the Tab Page for the input that will be adjusted and click the **Adjustment** Button to open the Adjustment Window.

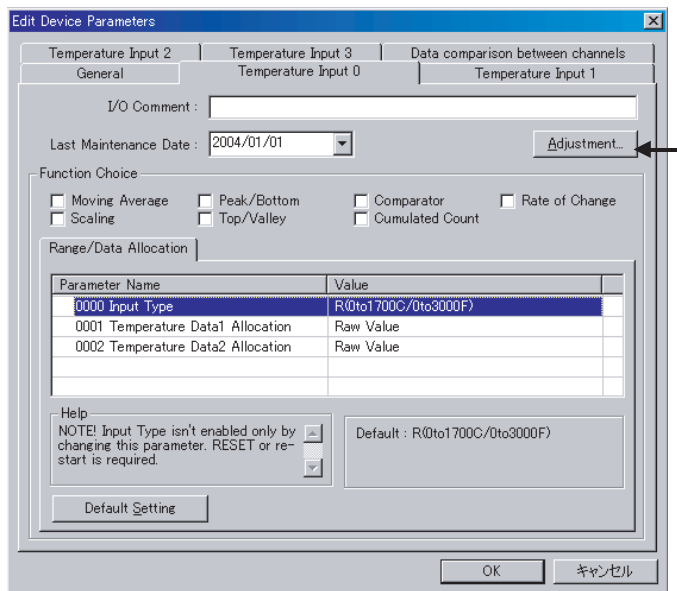

8. Adjust the lower limit value (lower adjusting value). Input 0 mV from the reference voltage/current generator (STV) to the Temperature Input Terminal's input terminals. Wait at least 1 minute for the input to stabilize.
9. Click the **Fix lower adjusting Value** Button. The lower limit adjustment value will be stored in the Unit.

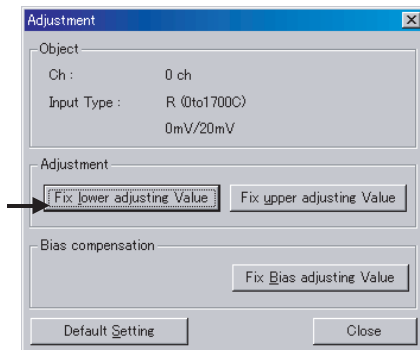

10. Adjust the upper limit value (upper adjusting value). Input the upper limit voltage from the reference voltage/current generator to the input terminals of the input to be adjusted. Refer to the following table for the appropriate voltage. Wait at least 1 minute for the input to stabilize.

Input type	Input voltage
K1	50 mV
K2	20 mV
J1	50 mV
J2	20 mV
T	20 mV
L1	50 mV
L2	20 mV
U	20 mV
N	50 mV
PL2	50 mV

- Click the **Fix upper adjusting Value** Button. The upper limit adjustment value will be stored in the Unit.

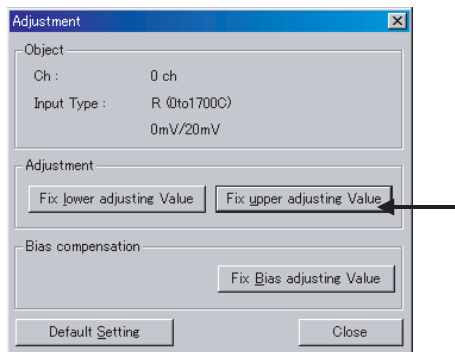

- To check whether the user adjustment values have been accepted and the Unit is operating with adjustment values different from the factory defaults, click the right mouse button over the Slave icon and select **Maintenance Information** to open the Maintenance Information Window. Select the Tab Page for the input that was adjusted. If there is a check in the *User Adjustment* Box (bottom right box), the Unit is operating with user-set adjustment values.

- Note**
- When checking whether or not the user adjustment values have been set correctly, always refresh the data by clicking the **Update** Button in the Maintenance Information Window's **General** Tab or uploading the settings again. For details on the Maintenance Information Window, refer to 7-3 *Maintenance Information Window*.
  - If the correct reference voltage was not input, the adjustment values may not be accepted.

■ **Adjusting the DRT2-TS04T's Bias Compensation Value**

- 1,2,3...**
- Disconnect the reference voltage/current generator (STV) and short the leads from the ZERO-CON (0°C bath).
  - After completing the wiring, wait at least 40 minutes, and click the **Fix Bias adjusting Value** Button. The bias compensation value will be stored in the Unit.

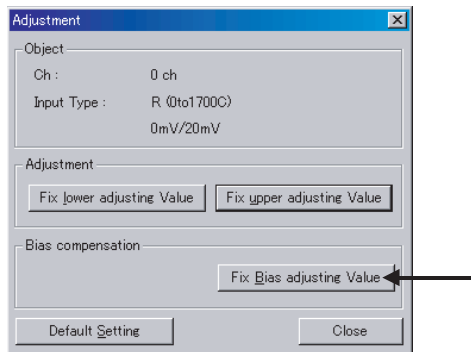

■ **Resetting User Adjustments**

If it is necessary to reset the upper limit adjustment value, lower limit adjustment value, and bias compensation value to the factory defaults, click the **Default Setting** Button. The settings will be returned to the factory settings. The upper/lower limit adjustment values and bias compensation value are all initialized at the same time.

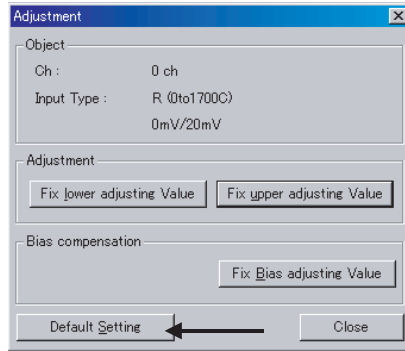

- Note**
1. The bias compensation value may not be accepted if there is a large temperature difference between the Terminal Block and ZERO-CON (0°C bath). If this problem occurs, correct the adjustment system by using a ZERO-CON compatible with the sensor being adjusted or other means.
  2. Always test the indication accuracy after making user adjustments to verify that the adjustments are correct. Test the indication accuracy at three points: the lower limit value, an intermediate value, and the upper limit value.
    - Connect the external devices as shown in the following diagram.
    - After verifying that the ZERO-CON is set to 0°C, set the STV's output voltage to produce a voltage equivalent to the test voltage.

**Note** Always use the compensating conductors (the same kind that will be used with the sensor being adjusted) to connect the ZERO-CON to the DRT2-TS04T's input terminals.

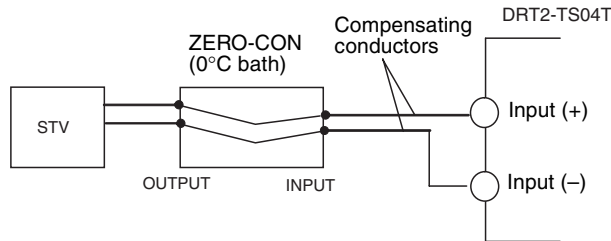

**Note** In order to perform the adjustment procedure properly, always allow sufficient time for temperature stabilization, as shown in the following diagram. Also allow sufficient time for devices such as the STV, DMM, and ZERO-CON to stabilize. Refer to each device's operating manual for details.

**Stabilization Times required in Each Step**

The following diagram shows the stabilization times (waiting times) required when adjusting all 4 inputs.

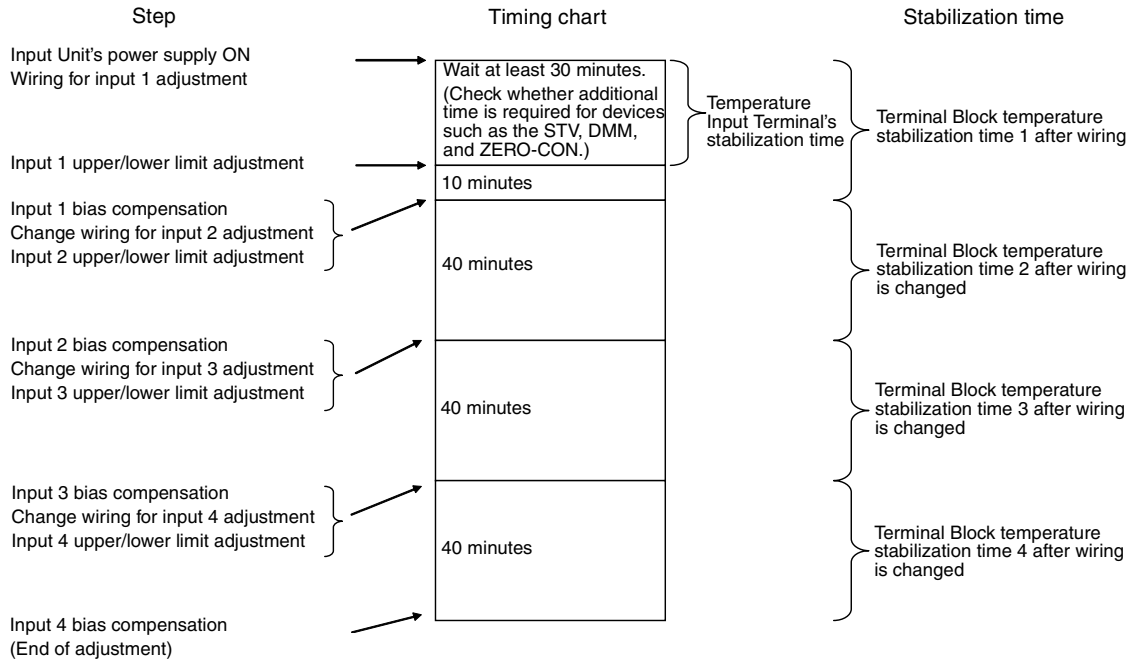

**Note** The terminal block temperature stabilization time does not affect the upper/lower limit adjustment after changing the wiring for inputs 2, 3, and 4, so the adjustment can be performed immediately if 30 minutes have passed since the Temperature Input Terminal's power was turned ON.

**Adjustment Procedure for the DRT2-TS04P**

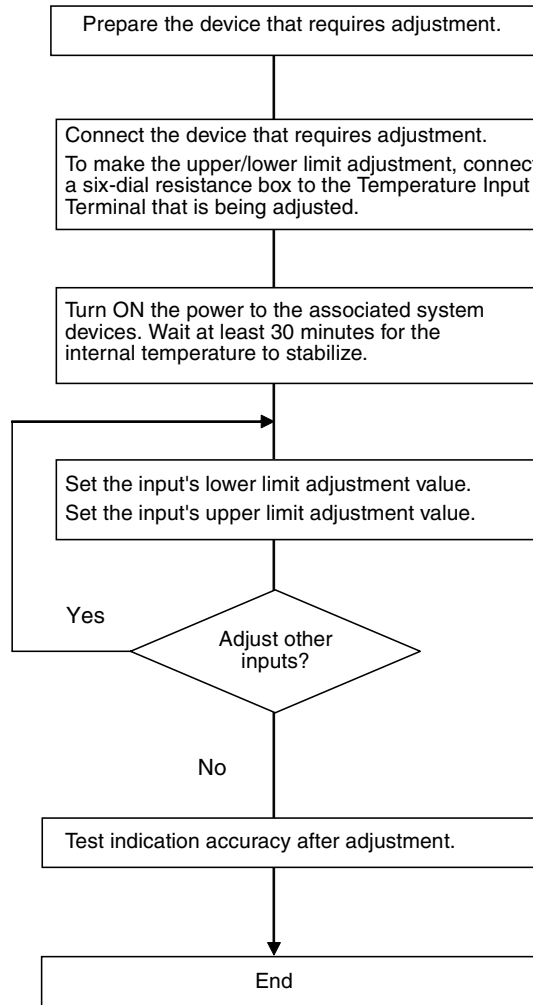

**Note** The only sensors that can be adjusted are ones that operate while the power supply is ON. When adjusting for sensors that are not presently in use, change the input type setting and perform the adjustment procedure from the beginning of the flowchart.

**Connecting the Devices required for DRT2-TS04P Adjustment**

The following paragraphs explain how to connect the devices that must be connected to the DRT2-TS04T for user adjustment. Wire the following devices properly when adjusting the DRT2-TS04T.

■ **Six-dial Resistance Box and Precision Digital Multimeter**

Used to make adjustments at the upper limit and lower limit.

Prepare device that can provide accurate resistance values for measurement. Use a precision digital multimeter that can measure the resistance values and indicate when the six-dial resistance box is not producing an accurate resistance.

■ **DeviceNet Configurator (Version 2.40 or Higher)**

The actual adjustment operations are performed with the Configurator. Check the version of the Configurator, because the DRT2-TS04P cannot be adjusted with an old version.

Refer to the DeviceNet Configurator Operation Manual for details on the Configurator.

**Adjustment Device Connection Diagram**

Connect the six-dial resistance box to the input terminals. In the following examples, the devices are connected to input 1, but connect to the corresponding terminals when adjusting inputs 2 to 4.

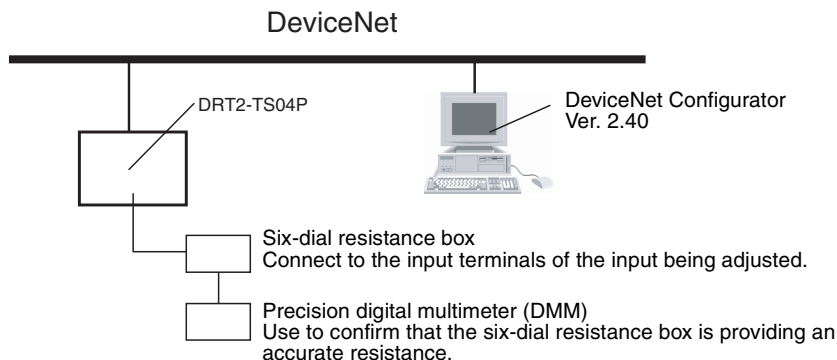

- Note**
1. When connecting the six-dial resistance box, use a cable with the same gauge as the one that will be used for operation.
  2. The personal computer (Configurator) is connected through DeviceNet in the diagram above. If a CS1W-DRM21 or CJ1W-DRM21 Master Unit is being used, the Configurator can also be connected through the Master Unit using a peripheral bus connection. Refer to the Configurator Operation Manual for details.

**Input Terminal Connections**

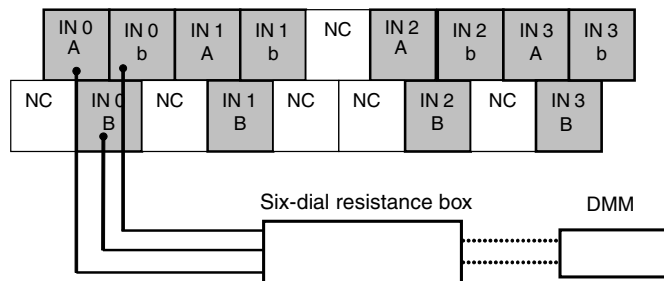

**Checking the Wiring and Making Adjustments**

■ **Adjusting the DRT2-TS04P’s Upper and Lower Limit Values**

- 1,2,3...**
1. Set the resistance value on the six-dial resistance box equivalent to the test value and properly wire the box to the input of the Temperature Input Terminal that is being adjusted.
  2. If the correct resistance cannot be obtained, properly wire the digital multimeter to the six-dial resistance box and measure the resistance.
  3. Connect the Configurator to the DeviceNet network and go online.
  4. Upload settings to the Configurator.
  5. Turn ON the power supplies of all Units, including the Temperature Input Terminal to be adjusted. Wait approximately 30 minutes for the Temperature Input Terminal’s internal temperature to stabilize.
  6. Double-click the icon of the Temperature Input Terminal to be set in the Main Window and open the Edit Device Parameters Window. (From the Maintenance Mode Window, click the right mouse button over the Slave icon and select **Parameters** and **Edit**.)

7. Select the Tab Page for the input that will be adjusted and click the **Adjustment** Button to open the Adjustment Window.

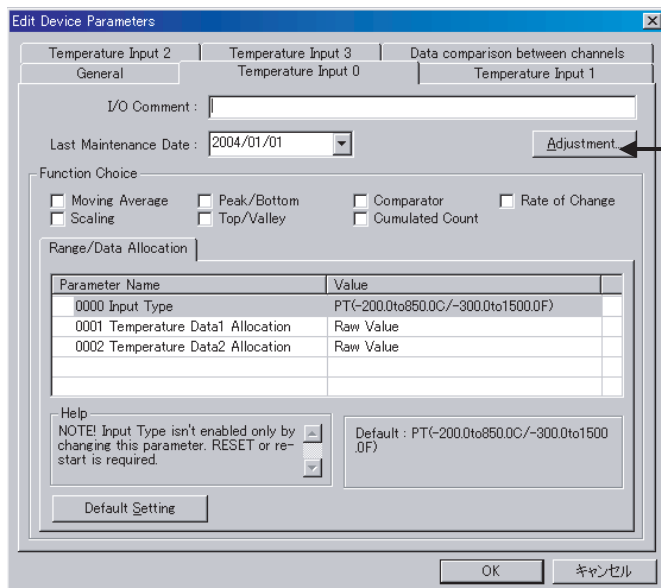

8. Adjust the lower limit value (lower adjusting value). Input 18 Ω from the six-dial resistance box to the Temperature Input Terminal's input terminals. Wait at least 1 minute for the input to stabilize.
9. Click the **Fix lower adjusting Value** Button. The lower limit adjustment value will be stored in the Unit.

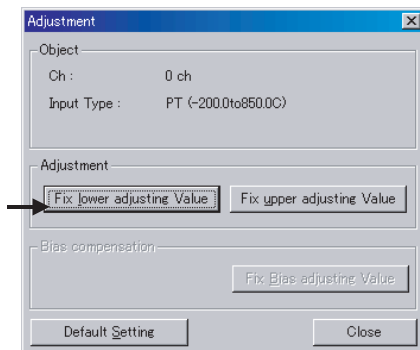

10. Adjust the upper limit value (upper adjusting value). Input either 180 Ω or 390 Ω from the six-dial resistance box to the input terminals of the input to be adjusted. Refer to the following table for the appropriate resistance. Wait at least 1 minute for the input to stabilize.

Input type	Input resistance for upper limit adjustment
PT	390 Ω
JPT	390 Ω
PT2	180 Ω
JPT2	180 Ω



11. Click the **Fix upper adjusting Value** Button. The upper limit adjustment value will be stored in the Unit.

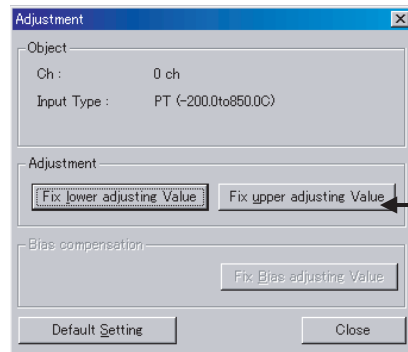

12. If it is necessary to restore the upper and lower limit adjustment values to the factory default settings, click the **Default Setting** Button. The settings will be returned to the factory settings.

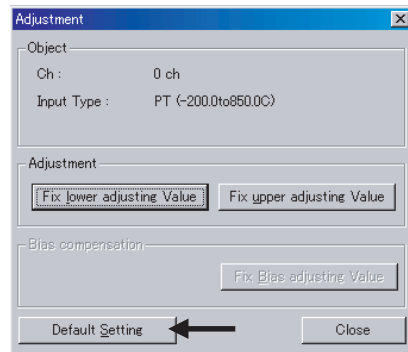

13. To check whether the user adjustment values have been accepted and the Unit is operating with adjustment values different from the factory defaults, click the right mouse button over the Slave icon and select **Maintenance Information** to open the Maintenance Information Window. Select the Tab Page for the input that was adjusted. If there is a check in the *User Adjustment* Box (bottom right box), the Unit is operating with user-set adjustment values.

- Note**
1. When checking whether or not the user adjustment values have been set correctly, always refresh the data by clicking the **Update** Button in the Maintenance Information Window's **General** Tab or uploading the settings again. For details on the Maintenance Information Window, refer to 7-3 *Maintenance Information Window*.
  2. Always test the indication accuracy after making user adjustments to verify that the adjustments are correct. Test the indication accuracy at three points: the lower limit value, an intermediate value, and the upper limit value.
    - Connect the external devices as shown in the following diagram.
    - Wait at least 30 minutes after the Temperature Input Terminal's power is turned ON and set the resistance value on the six-dial resistance box equivalent to the test value.

**Note** If the power supply is not turned OFF after making an adjustment, it is not necessary to wait 30 minutes before continuing testing.

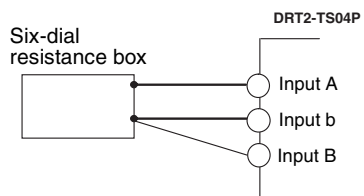



# SECTION 8

## Communications Timing

This section provides information on the time required for a complete communications cycle, for an output response to be made to an input, to start the system, and to send messages.

8-1	Remote I/O Communications Characteristics . . . . .	444
8-1-1	I/O Response Time . . . . .	444
8-1-2	Communications Cycle Time and Refresh Time . . . . .	449
8-1-3	More than One Master in Network . . . . .	451
8-1-4	System Startup Time . . . . .	452
8-2	Message Communications Characteristics . . . . .	453
8-2-1	Message Communications Time . . . . .	453

## 8-1 Remote I/O Communications Characteristics

This section describes the characteristics of DeviceNet remote I/O communications when OMRON Master and Slave Units are being used. Use this section for reference when planning operations that require precise I/O timing.

The equations provided here are valid under the following conditions:

- The Master Unit is operating with the scan list enabled.
- All of the required Slaves are participating in communications.
- No errors are being indicated at the Master Unit.
- Messages are not being produced in the Network (from another company's configurator, for example).

**Note** The values provided by these equations may not be accurate if another company's Master or Slave is being used in the Network.

### 8-1-1 I/O Response Time

The I/O response time is the time it takes from the reception of an input signal at an Input Slave to the output of the corresponding output signal at an Output Slave after being processed by the ladder program at the Master.

#### CVM1- and CV-series PLCs (Asynchronous Mode)

##### Minimum I/O Response Time

The minimum I/O response time occurs when the DeviceNet Master Unit refreshing is executed just after the input signal is received by the Master and instruction execution is completed within one peripheral servicing cycle.

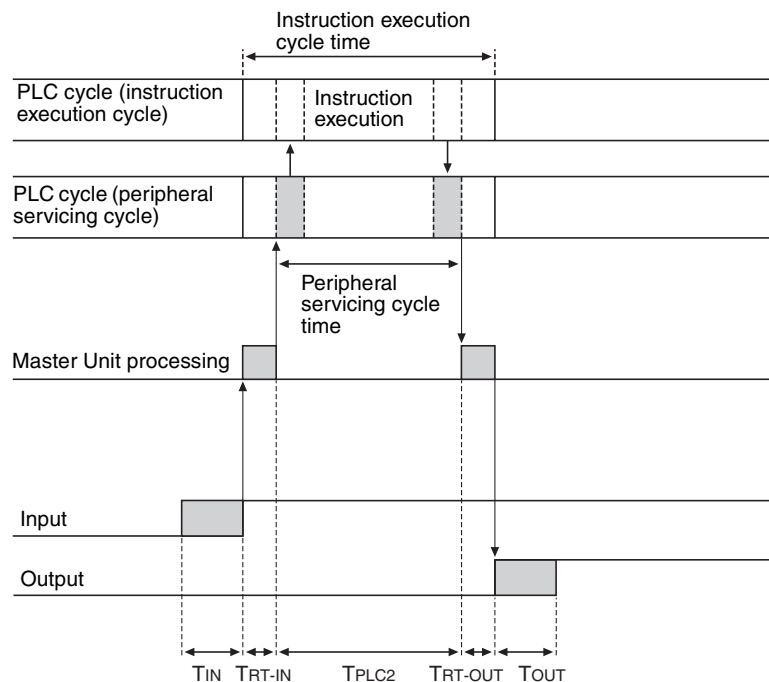

- $T_{IN}$ : The Input Slave's ON (OFF) delay (Minimum value: 0)
- $T_{OUT}$ : The Output Slave's ON (OFF) delay (Minimum value: 0)
- $T_{RT-IN}$ : The Input Slave's communications time/Slave (Refer to page 450.)
- $T_{RT-OUT}$ : The Output Slave's communications time/Slave (Refer to page 450.)

$T_{PLC2}$ : The PLC's peripheral servicing cycle time

**Note** Refer to *SECTION 5 General-purpose Slaves* and *SECTION 6 Environment-resistive Slaves* for details on Input and Output Slaves' ON and OFF delay times. Refer to *Refresh Time* on page 451 and the Operation Manual for the PLC being used for details on the PLC's peripheral servicing cycle time.

The minimum I/O response time ( $T_{MIN}$ ) is the total of the following terms:

$$T_{MIN} = T_{IN} + T_{RT-IN} + T_{PLC2} + T_{RT-OUT} + T_{OUT}$$

**Maximum I/O Response Time**

The maximum I/O response time occurs with the I/O timing shown in the following diagram.

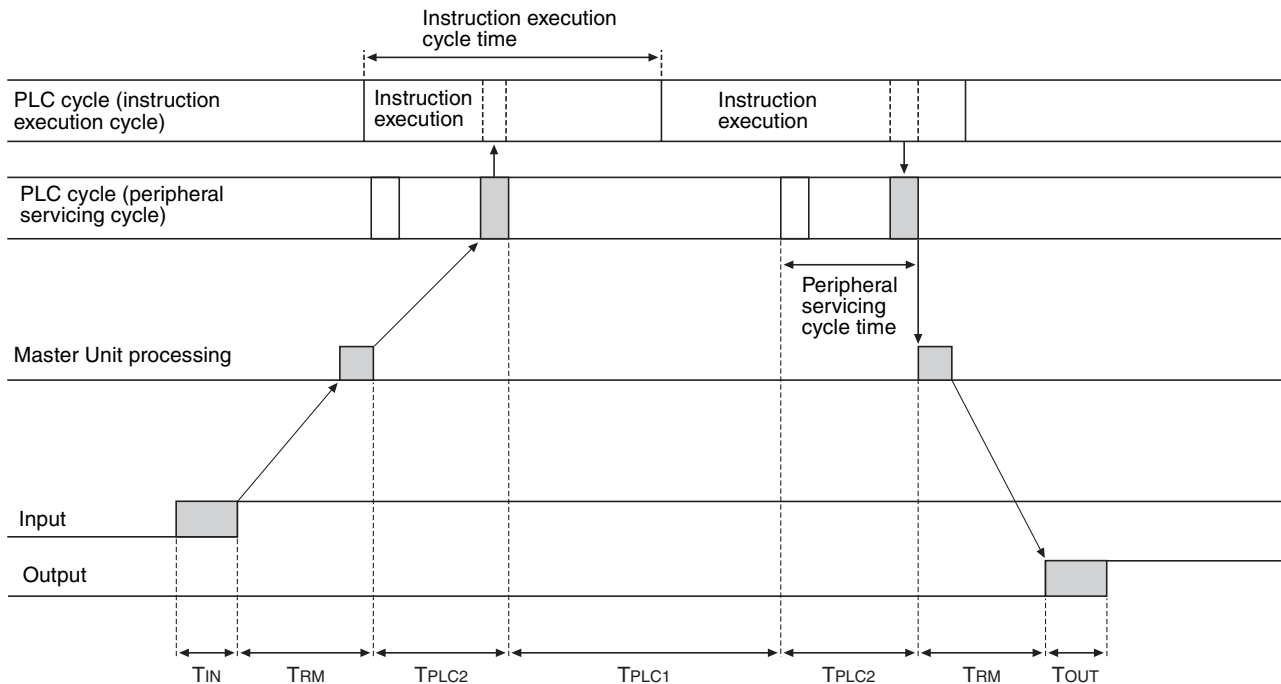

$T_{IN}$ : The Input Slave's ON (OFF) delay

$T_{OUT}$ : The Output Slave's ON (OFF) delay

$T_{RM}$ : The whole Network's communications cycle time (Refer to page 451.)

$T_{PLC1}$ : The PLC's instruction execution cycle time

$T_{PLC2}$ : The PLC's peripheral servicing cycle time

**Note** Refer to *SECTION 4 Functions of All Slaves, General-purpose Slaves, and Environment-resistive Slaves*, *SECTION 5 General-purpose Slaves* and *SECTION 6 Environment-resistive Slaves* for details on Input and Output Slaves' ON and OFF delay times. Refer to *Refresh Time* on page 451 and the Operation Manual for the PLC being used for details on the PLC's instruction execution and peripheral servicing cycle times.

The maximum I/O response time ( $T_{MAX}$ ) is the total of the following terms:

$$T_{MAX} = T_{IN} + 2 \times T_{RM} + T_{PLC1} + 2 \times T_{PLC2} + T_{OUT}$$

**CVM1- and CV-series PLCs (Synchronous Mode)**

**Minimum I/O Response Time**

The minimum I/O response time occurs with the I/O timing shown in the following diagram.

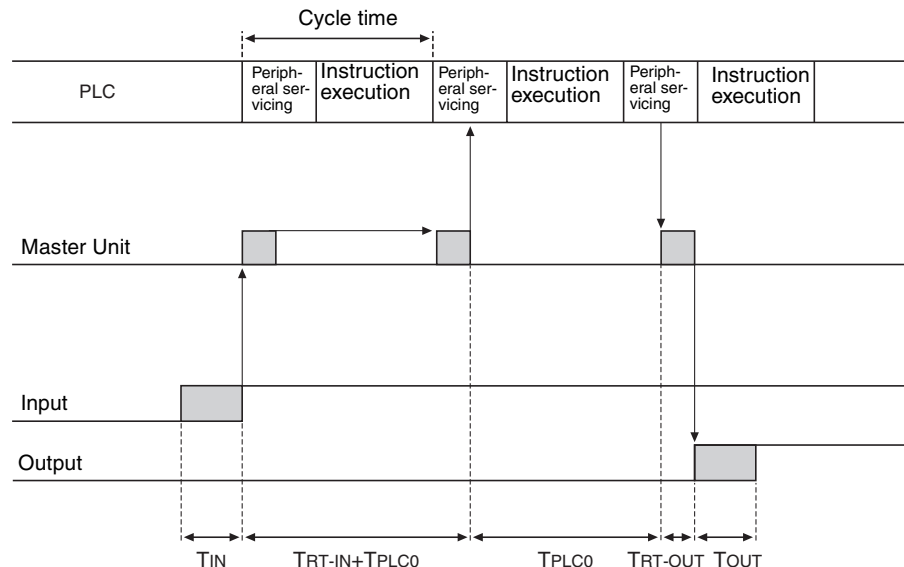

- T<sub>IN</sub>: The Input Slave's ON (OFF) delay (Minimum value: 0)
- T<sub>OUT</sub>: The Output Slave's ON (OFF) delay (Minimum value: 0)
- T<sub>RT-IN</sub>: The Input Slave's communications time/Slave (Refer to page 450.)
- T<sub>RT-OUT</sub>: The Output Slave's communications time/Slave (Refer to page 450.)
- T<sub>PLC0</sub>: The PLC's cycle time (instruction execution + peripheral servicing)

**Note** Refer to *SECTION 5 General-purpose Slaves* and *SECTION 6 Environment-resistive Slaves* for details on Input and Output Slaves' ON and OFF delay times. Refer to *Refresh Time* on page 451 and the Operation Manual for the PLC being used for details on the PLC's cycle time.

The minimum I/O response time (T<sub>MIN</sub>) is the total of the following terms:

$$T_{MIN} = T_{IN} + T_{RT-IN} + 2 \times T_{PLC0} + T_{RT-OUT} + T_{OUT}$$

**Maximum I/O Response Time**

The maximum I/O response time occurs with the I/O timing shown in the following diagram.

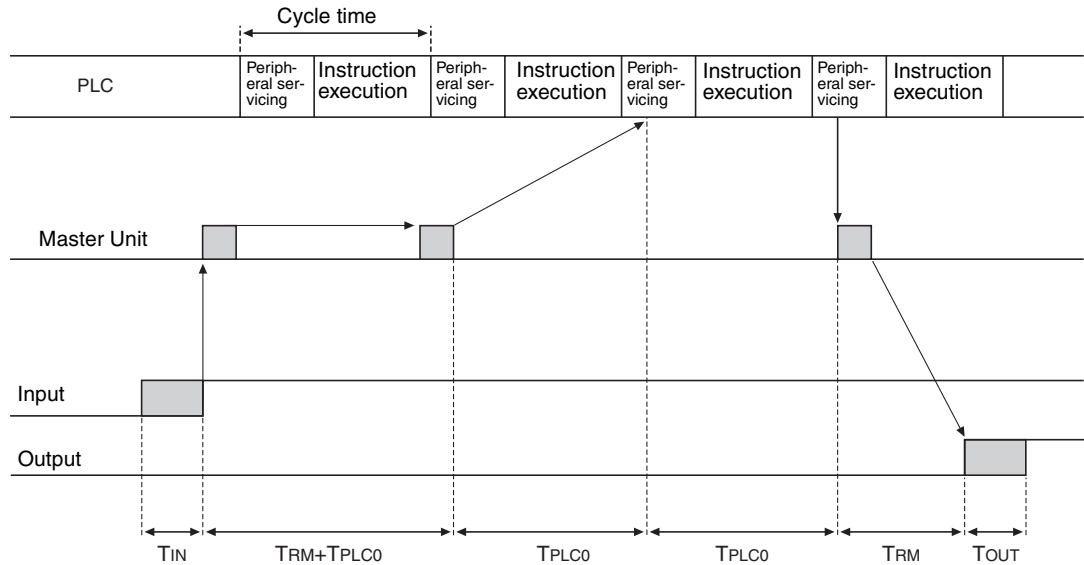

- $T_{IN}$ : The Input Slave's ON (OFF) delay
- $T_{OUT}$ : The Output Slave's ON (OFF) delay
- $T_{RM}$ : The whole Network's communications cycle time (Refer to page 449.)
- $T_{PLC0}$ : The PLC's cycle time (instruction execution + peripheral servicing)

**Note** Refer to SECTION 5 General-purpose Slaves and SECTION 6 Environment-resistive Slaves for details on Input and Output Slaves' ON and OFF delay times. Refer to Refresh Time on page 451 and the Operation Manual for the PLC being used for details on the PLC's instruction execution and peripheral servicing cycle times.

The maximum I/O response time ( $T_{MAX}$ ) is the total of the following terms:

$$T_{MAX} = T_{IN} + 2 \times T_{RM} + 3 \times T_{PLC0} + T_{OUT}$$



**CS, CJ, C200HX/HG/HE (-Z), and C200HS PLCs****Minimum I/O Response Time**

The minimum I/O response time occurs when the DeviceNet Slave I/O refreshing is executed just after the input signal is received by the Master and I/O is refreshed for the Slave first in the next I/O refresh cycle.

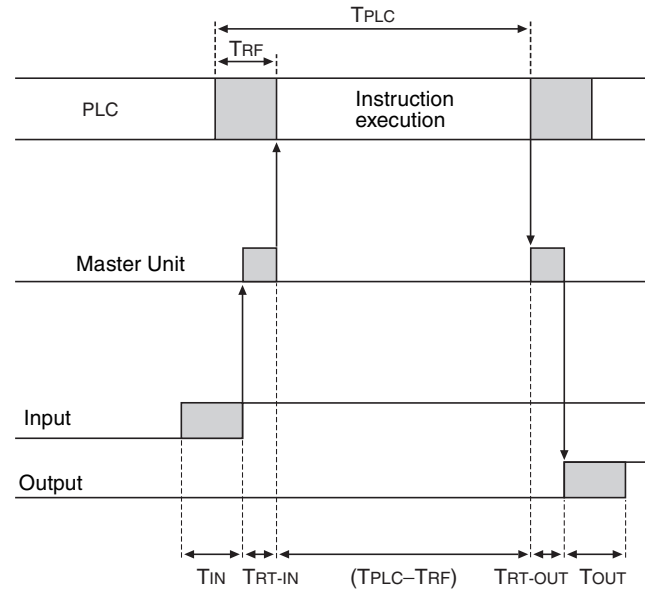

$T_{IN}$ : The Input Slave's ON (OFF) delay (Minimum value: 0)

$T_{OUT}$ : The Output Slave's ON (OFF) delay (Minimum value: 0)

$T_{RT-IN}$ : The Input Slave's communications time/Slave (Refer to page 450.)

$T_{RT-OUT}$ : The Output Slave's communications time/Slave (Refer to page 450.)

$T_{PLC}$ : The PLC's cycle time

$T_{RF}$ : The PLC's DeviceNet Unit refresh time (Refer to page 451.)

**Note** Refer to *SECTION 5 General-purpose Slaves* and *SECTION 6 Environment-resistive Slaves* for details on Input and Output Slaves' ON and OFF delay times. Refer to *Refresh Time* on page 451 and the Operation Manual for the PLC being used for details on the PLC's cycle time.

The minimum I/O response time ( $T_{MIN}$ ) is the total of the following terms:

$$T_{MIN} = T_{IN} + T_{RT-IN} + (T_{PLC} - T_{RF}) + T_{RT-OUT} + T_{OUT}$$

**Maximum I/O Response Time**

The maximum I/O response time occurs with the I/O timing shown in the following diagram.

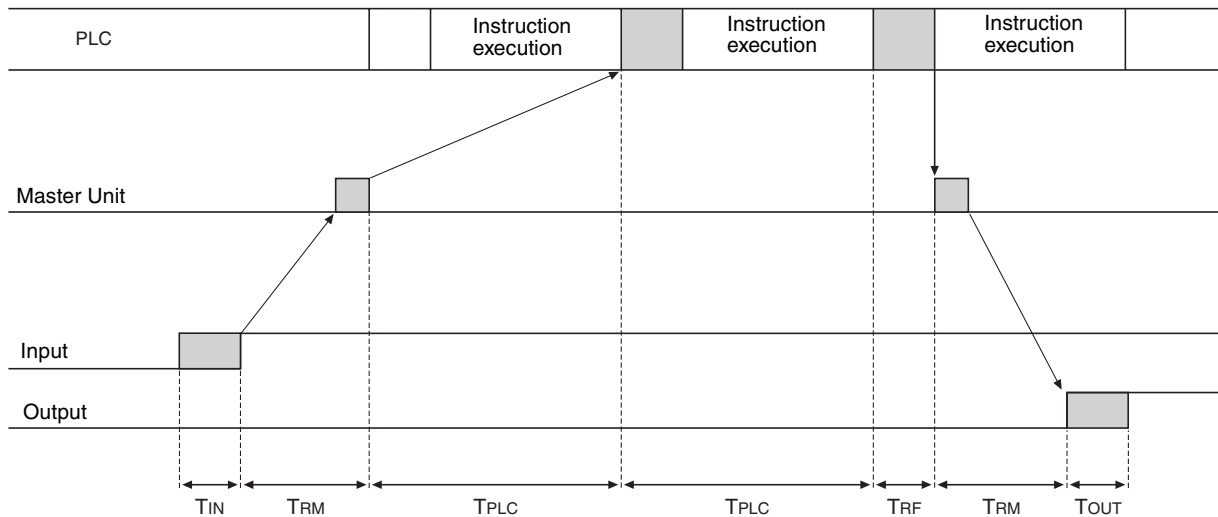

- $T_{IN}$ : The Input Slave's ON (OFF) delay
- $T_{OUT}$ : The Output Slave's ON (OFF) delay
- $T_{RM}$ : The whole Network's communications cycle time (Refer to page 450.)
- $T_{PLC}$ : The PLC's cycle time
- $T_{RF}$ : The PLC's DeviceNet Unit refresh time (Refer to page 451.)

**Note** Refer to *SECTION 5 General-purpose Slaves* and *SECTION 6 Environment-resistive Slaves* for details on Input and Output Slaves' ON and OFF delay times. Refer to *Refresh Time* on page 451 and the Operation Manual for the PLC being used for details on the PLC's cycle time.

The maximum I/O response time ( $T_{MAX}$ ) is the total of the following terms:

$$T_{MAX} = T_{IN} + 2 \times T_{RM} + 2 \times T_{PLC} + T_{RF} + T_{OUT}$$

**8-1-2 Communications Cycle Time and Refresh Time**

The communications cycle time, communications time for each Slave, and refresh time are explained in this section. All of these times are necessary for calculating the time required for various processes in a DeviceNet Network.

**Communications Cycle Time**

The communications cycle time is the time from the completion of a Slave's remote I/O communications processing until remote I/O communications with the same Slave are processed again. The communications cycle time is also used to calculate the maximum I/O response time.

The communications cycle time depends on several factors, including the number of Masters on the Network and on whether or not message communications are being performed. The following examples provide equations for when there is only one Master Unit. For details on cycle time equations for multiple Master Units, refer to page 451.

The following equations show the communications cycle time ( $T_{RM}$ ) when there is only one Master in the Network.

Even if the equation result is less than 2 ms, the minimum communications cycle time ( $T_{RM}$ ) is 2 ms.

$$T_{RM} = \Sigma (\text{communications time for each Slave}) \\ + \text{MULTIPLE I/O TERMINAL processing time} \\ + \text{Explicit message communications time} \\ + \text{COS/Cyclic connection communications time [ms]} \\ + 0.01 \times N + 1.0 \text{ [ms]}$$

Communications time for each Slave:

Time required for each Slave. (Refer to pages 450 to 451.)  $\Sigma$  (communications time for each Slave) is the total of the processing of each Slave in the Network.

MULTIPLE I/O TERMINAL processing time:

$$3.5 \text{ [ms]}$$

Only when Slaves with input, output or mixed I/O of more than 8 bytes exist.

Explicit message communications time:

$$0.11 \times T_B + 0.6 \text{ [ms]}$$

Added as delay time when explicit message communications (send or receive) are used.

$T_B$ : Constant (500 kbps:  $T_B = 2$ ; 250 kbps:  $T_B = 4$ ; 125 kbps:  $T_B = 8$ )

COS/Cyclic connection communications time:

$$(0.05 + 0.008 \times S) \times T_B \times n \text{ [ms]}$$

Added as delay time when COS/Cyclic connection is used for communications.

$S$ : Total size (bytes) of the COS/Cyclic connection's input size and output size.

$n$ : Number of nodes for which COS/Cyclic connections occur at the same time during one communications cycle.

$N$ : Number of Slaves

### **Communications Time for each Slave**

The communications time for each Slave is the time required for communications to be performed with a single Slave.

The following equations show the communications time per Slave ( $T_{RT}$ ) for each kind of Slave Unit.

#### **Output Slaves with up to 8 Bytes of Output**

$$T_{RT} = 0.016 \times T_B \times S_{OUT1} + 0.11 \times T_B + 0.07 \text{ [ms]}$$

$S_{OUT1}$ : The number of Output Slave output words

$T_B$ : The baud rate (500 kbps:  $T_B = 2$ ; 250 kbps:  $T_B = 4$ ; 125 kbps:  $T_B = 8$ )

#### **Input Slaves with up to 8 Bytes of Input**

$$T_{RT} = 0.016 \times T_B \times S_{OUT1} + 0.06 \times T_B + 0.05 \text{ [ms]}$$

$S_{IN1}$ : The number of Input Slave input words

$T_B$ : The baud rate (500 kbps:  $T_B = 2$ ; 250 kbps:  $T_B = 4$ ; 125 kbps:  $T_B = 8$ )

#### **Mixed I/O Slaves with up to 8 Bytes of I/O**

$$T_{RT} = 0.016 \times T_B \times (S_{OUT2} + S_{IN2}) + 0.11 \times T_B + 0.07 \text{ [ms]}$$

$S_{OUT2}$ : The number of Mixed I/O Slave output words

$S_{IN2}$ : The number of Mixed I/O Slave input words

$T_B$ : The baud rate (500 kbps:  $T_B = 2$ ; 250 kbps:  $T_B = 4$ ; 125 kbps:  $T_B = 8$ )

**Input Slaves, Output Slaves, or Mixed I/O Slaves with More than 8 Bytes of I/O**

$$T_{RT} = T_{OH} + T_{BYTE-IN} \times B_{IN} + T_{BYTE-OUT} \times B_{OUT} \text{ [ms]}$$

- T<sub>OH</sub>: The overhead protocol
- T<sub>BYTE-IN</sub>: The input byte transmission time
- B<sub>IN</sub>: The number of input bytes
- T<sub>BYTE-OUT</sub>: The output byte transmission time
- B<sub>OUT</sub>: The number of output bytes

Baud rate	T <sub>OH</sub>	T <sub>BYTE-IN</sub>	T <sub>BYTE-OUT</sub>
500 kbps	0.306 ms	0.040 ms	0.036 ms
250 kbps	0.542 ms	0.073 ms	0.069 ms
125 kbps	1.014 ms	0.139 ms	0.135 ms

The number of output bytes (B<sub>OUT</sub>) for Input Slaves only is 0, and the number of input bytes (B<sub>IN</sub>) for Output Slaves only is 0.

**Refresh Time**

The refresh time is the time required for I/O data to be exchanged between the PLC's CPU Unit and the DeviceNet Master Unit. The PLC's cycle time is increased when a Master Unit is mounted, as shown below.

**Note** Refer to the PLC's Operation Manual for more details on the refresh time and the PLC's cycle time.

**Master Unit for CV-series PLCs**

The PLC's cycle time (CPU Bus Unit servicing) is increased by the amount shown in the following table when a Master Unit is mounted to the PLC.

Process	Processing time
CPU Bus Unit servicing	DeviceNet Unit refreshing: 1.1 ms

**Master Unit for CS, CJ, C200HX/HG/HE (-Z), and C200HS PLCs**

The PLC's cycle time (I/O refreshing) is increased by the amount shown in the following table when a Master Unit is mounted to the PLC.

Process	Processing time
I/O refreshing	DeviceNet Unit I/O refreshing: Using Master Unit for CS, CJ, and C200HX/HG/HE (-Z) PLCs $1.72 + 0.022 \times \text{number of words (ms)}$ (See note.) Using Master Unit for C200HS PLCs $2.27 + 0.077 \times \text{number of words (ms)}$ (See note.)

**Note** The number of words refreshed is the total number of words in the I/O Area that are allocated to the Slaves, including any unused words between those words actually used by the Slaves.

For example, if there are only two Input Slaves with node addresses 1 and 5, the 5 input words for nodes 1 through 5 would be refreshed even though the input words for nodes 2, 3, and 4 are unused.

If message communications are being performed, just add the number of words used in message communications to the above number of words for whenever messages are being processed.

**8-1-3 More than One Master in Network**

The following equation shows the communications cycle time (T<sub>RM</sub>) when there is more than one Master in the Network.

An example for two Master Units is shown here.

First, the Network is divided into two groups: Master A and the Slaves in remote I/O communications with it, and Master B and the Slaves in remote I/O communications with it.

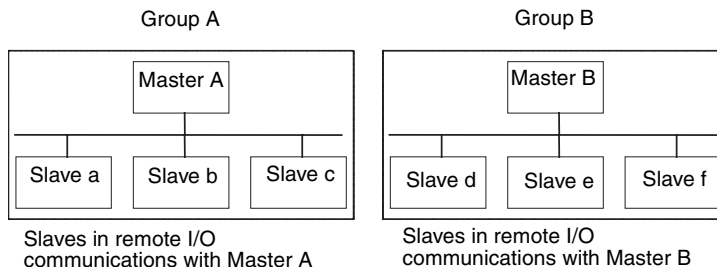

**Note** Although in the above diagram the Slaves are separated into two separate groups for each Master for convenience, the actual physical positions of the Slaves in the Network are irrelevant.

Next, refer to page 450 and calculate the communications cycle time for each group as if they were separate Networks.

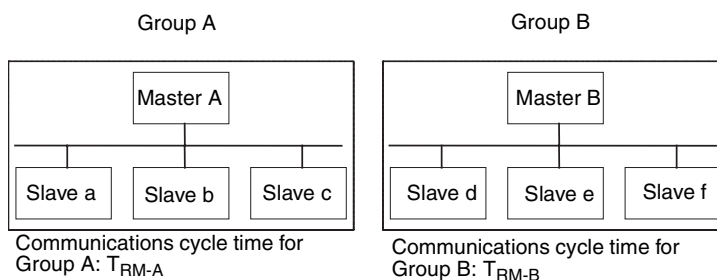

In Networks with two Masters, the communications cycle time for the entire Network will be the sum of the communications cycle times for both groups.

$$T_{RM} = T_{RM-A} + T_{RM-B}$$

Although this example shows only two Masters in the Network, the total communications cycle time for any Network with more than one Master can be calculated by dividing it into groups performing remote I/O communications and adding the communications cycle times of all the groups.

### 8-1-4 System Startup Time

This section describes the system startup time for a Network, assuming that the scan list is enabled and that remote I/O communications are set to start automatically at startup. The system startup time is the delay from the time that the Master Unit is turned ON or restarted until the time remote I/O communications begin.

The system startup time when the Master Unit is set to start up immediately after power supplies of all the Slaves' are turned ON is different from when the Master Unit is restarted while communications are in progress. The startup times are shown in the following table.

Condition	Slave's indicator status	System startup time
The Master is started immediately after Slave startup.	NS indicator is OFF or flashing green.	6 s
The Master only is restarted.	NS indicator is flashing red while the Master is OFF.	8 s
The Slaves only are restarted.	---	10 s

**Program Example**

As shown in the preceding table, it takes time for DeviceNet communications to start up. This programming uses flags in the Master Status Area to prevent the Slaves' I/O processing from being performed until the Master Unit and remote I/O communications have started up.

**Note** Refer to the operation manual of the Master Unit being used for details on the Master Unit Status Area.

The following program example is for a CS1-series PLC and a Master Unit with a unit number of 00.

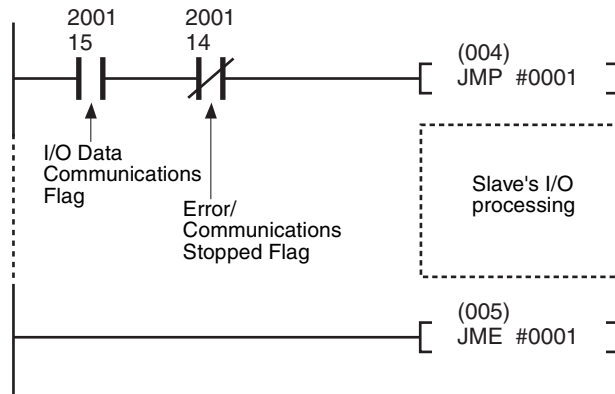

## 8-2 Message Communications Characteristics

### 8-2-1 Message Communications Time

The message communications time is the time required from the time a Master Unit starts to send a message over the Network to another node until the Master Unit completes sending the message (SEND(090)/RCV(098) instructions to send/receive data and CMND(490)/IOWR(223) instructions to execute FINS commands).

**Note** If the CPU Unit attempts to send another message or receives a message from another node before the message communications time has finished, the response message being sent or the message being received from another node may be destroyed. Always perform message communications at intervals longer than the message communications time and use message instructions (SEND(090), RCV(098), CMND(490), and IOWR(223)). Never send messages to any one node at intervals less than the message communications time.

If send or receive messages are destroyed, the error record will be placed in the error history of the Master Unit. If an error occurs, read the error history using the FINS command or monitor the error history from the Configurator.

The following equation can be used to calculate the approximate message communications time.

$$\text{Message communications time} = \text{Communications cycle time} \left( (\text{No. of message bytes} + 15) \div 6 + 1 \right)$$

The number of message bytes is the number of data bytes following the FINS command code. The communications cycle time depends on whether remote I/O communications are being used.

**Message Communications Only (Remote I/O Communications Not Used)**

Message communications time = 2 (see note) + 0.11 × T<sub>B</sub> + 0.6 (ms)

T<sub>B</sub>: Baud rate (500 kbps: T<sub>B</sub> = 2; 250 kbps: T<sub>B</sub> = 4; 125 kbps: T<sub>B</sub> = 8)

**Note** The communications cycle when remote I/O communications are not being used is 2 ms.

**Message Communications with Remote I/O Communications**

Communications cycle time = (Communications cycle time for remote I/O communications only) + 0.11 × T<sub>B</sub> + 0.6 (ms)

T<sub>B</sub>: Baud rate (500 kbps: T<sub>B</sub> = 2; 250 kbps: T<sub>B</sub> = 4; 125 kbps: T<sub>B</sub> = 8)

**Note** The above equations can be used to find the approximate message communications time, but not the maximum time. The message communications time will depend on the frequency of the message communications, the load on the remote node, the communications cycle time, and other factors. For any one Master Unit, the message communications time may be greatly increased due to heavy loads.

# SECTION 9

## Troubleshooting and Maintenance

This section describes error processing, periodic maintenance operations, and troubleshooting procedures needed to keep the DeviceNet Network operating properly. We recommend reading through the error processing procedures in both this manual and the operation manual for the master being used before operation so that operating errors can be identified and corrected more quickly.

9-1	Indicators and Error Processing .....	456
9-2	Troubleshooting .....	457
9-2-1	Troubleshooting by LED Indicators .....	457
9-2-2	Troubleshooting by Slave Model .....	460
9-3	Maintenance .....	466
9-3-1	Cleaning .....	466
9-3-2	Inspection .....	466
9-3-3	Replacing Units .....	467

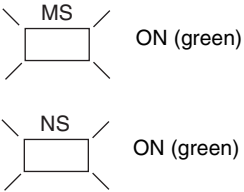
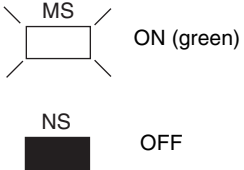
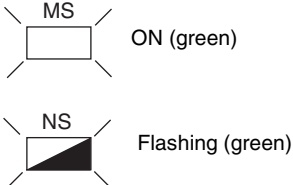
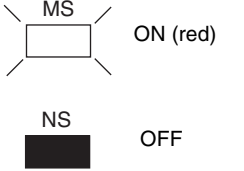
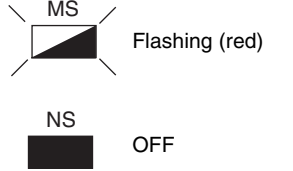
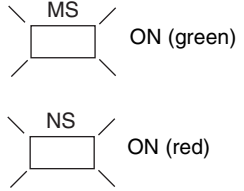

## 9-1 Indicators and Error Processing

MS/NS indicators	Details		Probable cause and remedy
 <p>MS ON (green) NS ON (green)</p>	Remote I/O communications or message communications in progress	Remote I/O Communications or message communications in progress	Remote I/O communications and/or message communications are being performed. (Normal status)
 <p>MS ON (green) NS OFF</p>	Checking for node address duplication	Checking for node address duplication at the Master.	If this indicator status has occurred for only specific Slaves, check that the Slave baud rate settings are correct and then restart them.
 <p>MS ON (green) NS Flashing (green)</p>	Waiting for connection	Waiting for connection to be established with Master.	
 <p>MS ON (red) NS OFF</p>	Watchdog timer error	Watchdog timer error has occurred in Slave	Replace the Slave Unit.
 <p>MS Flashing (red) NS OFF</p>	Switch settings are incorrect.	The DIP switch or other switch settings are incorrect.	Check the switch settings and restart the Slave Unit.
 <p>MS ON (green) NS ON (red)</p>	Node address duplication	Slave Unit has been assigned the same node address as the Master Unit.	Reset the Slave Unit so that it has a unique node address, and then restart the Slave Unit.

MS/NS indicators	Details		Probable cause and remedy
<p>MS ON (green)</p> <p>NS ON (red)</p>	<p>Bus Off error detected</p>	<p>Bus Off status (communications stopped due to multiple data errors)</p>	<p>Check the following items and restart the Slave.</p> <p>Do Master/Slave baud rates match?</p> <p>Are lengths of cables (trunk and branch lines) correct?</p> <p>Are cables loose?</p> <p>Are Terminating Resistors connected to both ends of the trunk line only?</p> <p>Is noise interference excessive?</p>
<p>MS ON (green)</p> <p>NS Flashing (red)</p>	<p>Communications time-out.</p>		<p>Check the following items and restart the Slave.</p> <p>Do Master/Slave baud rates match.</p> <p>Are lengths of cables (trunk and branch lines) correct?</p> <p>Are cables loose?</p> <p>Are Terminating Resistors connected to both ends of the trunk line only?</p> <p>Is noise interference excessive?</p>

## 9-2 Troubleshooting

### 9-2-1 Troubleshooting by LED Indicators

#### Red Indicator (ON or Flashing)

<p>MS indicator is a constant red.</p>	<p>The Slave Unit is faulty. Replace the Slave Unit if it is faulty.</p> <p>The Expansion Unit has been removed or disconnected. Check the Expansion Unit.</p>
<p>MS indicator is flashing red.</p>	<p>An error has occurred in the Slave's internal non-volatile memory data. Double-click the icon of the Slave in the Main Window and open the Edit Device Parameters Window. Click the <b>Default Setup</b> Button, and then click the <b>Reset</b> Button. If the MS indicator continues to flash red after returning the data to the default status, replace the Slave Unit.</p> <p>The DIP switch settings or other settings are incorrect. Check the switch settings and restart the Slave Unit.</p> <p>The cold junction compensator has been removed or disconnected (DRT2-TS04T only). Check the cold junction compensator.</p>

<p>After the MS indicator is lit green, the NS indicator changes to red immediately without flashing green.</p>	<p>Check the following points and then restart the faulty Slave.                  Check for a node address duplication.                  Check all the node addresses. If required, change settings so that each node has a unique node address.                  See the troubleshooting steps below under the error heading "The NS indicator lights green but changes to red after a short time."                  If a particular Slave's NS indicator is always red, replace that Slave.</p>
<p>The NS indicator lights green but changes to red after a short time.                  OR                  The NS indicator lights green but flashes red after a short time.</p>	<p>Check the following points and then restart the faulty Slave.                  Make sure that there are 121-Ω Terminating Resistors connected at both ends of the trunk line.                  Connect 121-Ω Terminating Resistors if the resistance is not correct.                  Check whether all of the Slaves' settings are correct.                  Check whether the communications cables are connected properly.                  Check whether the power supply is set correctly and the power supply cables are connected properly.                  Check all the nodes for broken wires in the communications and power supply cables attached to the connectors.                  Check whether communications power is correctly supplied to the network.                  If there is nearby equipment that generates electrical noise, take steps to shield the Master, Slaves, and communications cables from the noise.                  If an error has occurred in a network with an OMRON Master Unit, refer to the Master Unit's Operation Manual.                  If an error has occurred in a network with a another company's Master Unit, refer to the relevant operation manual.                  If a particular Slave's NS indicator is always red, replace that Slave.</p>

**Trouble Adding a Slave to the Network**

<p>The NS indicator remains OFF</p>	<p>Check that the Slave's connector is connected correctly.                  Check that the Master is operating properly.                  When using an OMRON Master Unit, refer to the Master Unit's Operation Manual.                  If another company's Master is being used, refer to the relevant operation manual.                  Check whether the communications cables are connected properly.                  Check whether the power supply is set correctly and the power supply cables are connected properly.                  Check for broken wires in the communications and power supply cables attached to the connectors.</p>
-------------------------------------	--

<p>The NS indicator continues to flash green.</p>	<p>Check that the Master is operating properly.                  When using an OMRON Master Unit, refer to the Master Unit's Operation Manual.                  If another company's Master is being used, refer to the relevant operation manual.                  Check whether the Slave is registered in the Master's scan list.                  If an OMRON Master Unit is being used, a new Slave cannot be added to the network if the Master is operating with the scan list enabled.                  First clear the scan list, check that all the Slaves have joined the network, and then create the scan list.                  If another company's Master is being used, refer to the relevant operation manual for details on registering a new Slave in its scan list.</p>
<p>The NS indicator alternates between being a constant green and flashing green OR                  The NS indicator alternates between flashing red and flashing green</p>	<p>When using an OMRON Master Unit, check the following points and perform the error processing steps according to the indicator status.                  Register the scan list again.                  First clear the scan list, check that all the Slaves have joined the network, and then create the scan list.                  Check that the Slave's allocated I/O Area does not overlap with that of another Slave. If there is an overlap, change the Slave's node address to eliminate the overlap.                  Check that the allocated I/O Area does not exceed the allowable range shown below. If the I/O Area exceeds this range, change the Slave's node address to correct the problem.                  When using another company's Master Unit, check that the I/O size registered in the Master's scan list matches the actual I/O size of the Slave.                  The I/O size is recorded in the following attributes of the Connection Object:                      Interface 2 (Polled I/O Connection)                      Interface 4 (COS/cyclic Connection)                          Produced Connection Size (input size)                          Consumed Connection Size (output size)                  and:                      Interface 3 (Bit-strobed I/O Connection)                          Produced Connection Size (input size)                    Refer to <i>Appendix B Using Another Company's Master Unit</i>, and register the correct values in the Master Unit's scan list.                  Refer to the Master Unit's operation manual for details on registering values.</p>

### 9-2-2 Troubleshooting by Slave Model

Model	Details	Probable cause	Remedy
Errors occurring all Slaves	MS and NS indicators are a constant red.	See 9-2-1 <i>Troubleshooting by LED Indicators</i> .	---
	The Network Power Voltage Error Flag does not go ON even when the network power supply voltage drops.	The network power voltage monitor value is set too low. (The default setting is 11 V.)	Increase the network power voltage monitor value.
	The appropriate network power supply voltage is being supplied, but a Network Power Voltage Error is still detected.	The network power voltage monitor value is set too high.	Decrease the network power voltage monitor value.
	The network power voltage monitor value cannot be set.	The 11 to 25 V setting range has been exceeded.	Set a value within the 11 to 25 V setting range.
	The I/O comment or Unit comment cannot be set.	A comment longer than 32 characters is being set.	Set a comment up to 32 characters long.
	The Unit Maintenance or Connected Device Maintenance Status Flag will not go ON.	The maintenance status function is disabled if the monitor value is set to 0.	Set the monitor value to a non-zero value.
	One of the following values was not held at its previous value when the Unit's power was turned ON again. General-purpose Slaves: Unit Conduction Time or Maintenance Counter value Temperature Input Terminals: Temperature Range Total Time or Top/Valley Count value	When the power is ON, these values are saved to the Unit's non-volatile memory once every 6 minutes. The Save Maintenance Counter function can be used to save these values immediately. If the power is turned OFF without saving the values, the last stored values (up to 6 minutes old) will be read.	Execute the Save Maintenance Counter function before turning OFF the power.
Errors occurring in all Slaves except the Analog Slaves	The Maintenance Counter value returned to 0.	The counter is reset to 0 when the Unit is reset. The counter is reset to 0 when the Maintenance Counter setting is switched between Total ON Time Monitor and Contact Operation Counter.	---
	Parameters were edited or set, but some functions were not changed.	The changed function will be enabled only when power is turned OFF and ON again.	Reset the Slave by turning the power OFF and ON, or resetting from the Configurator.
	An output is turned ON, but the Maintenance Counter is not incremented.	The I/O power supply is OFF.	Check whether the I/O power supply is being supplied.

Model	Details	Probable cause	Remedy
Errors occurring in Slaves that support Expansion Units DRT2-ID16(-1) DRT2-OD16(-1) DRT2-ROS16	I/O communications could not be used after mounting the Expansion Unit and turning ON the power.	When an Expansion Unit is mounted or removed the number of I/O points changes, so the Master's scan list may not match the actual system.	Set the Master's scan list again.
	An Expansion Unit was mounted or removed online and the MS indicator is lit red.	Expansion Units cannot be mounted or removed online	Turn OFF the power before mounting or removing an Expansion Unit.
	The Operation Time Monitor function cannot be used.	This function is usable only when an Input Unit and Output Unit are used together.  With the DRT2-ID16(-1): Function is usable only when an XWT-OD08(-1) or XWT-OD16(-1) is mounted.  With the DRT2-OD16(-1) or DRT2-ROS16: Function is usable only when an XWT-ID08(-1) or XWT-ID16(-1) is mounted.  The function is not supported by the DRT2-ID08(-1), DRT2-OD08(-1), DRT2-ID16S, DRT2-HD16C, DRT2-ID08C, or DRT2-OD08C.	---
Errors occurring in Slaves that support the Operation Time Monitor function DRT2-ID16(-1)* DRT2-OD16(-1)* DRT2-ROS16* DRT2-MD16(-1) DRT2-MD16S(-1) DRT2-□D16TA(-1) DRT2-□D16ML(X)(-1) DRT2-□D32ML(-1) DRT2-□D32B/BV(-1) DRT2-□D□□SL/SLH(-1) DRT2-□D04CL(-1) DRT2-MD16CL(-1)  * Supported only when an Expansion Unit is mounted and the Slave can be used as an I/O Unit.	The Operation Time Monitor is not showing the expected value.	When the input filter is being used, there will be a delay in the ON time or OFF time.  In Slaves other than the Basic, Sensor Connector types, and Environment-resistive Slaves, the operation time can be set to measure from the rising edge or falling edge of the signals. This setting may be incorrect.  In Slaves other than the Basic and Sensor Connector types, the operation time combination can be set. If the values are not as expected, this setting may be incorrect. The accuracy is ±6 ms.	Take into account the effect of the filter settings on the Operation Time Monitor or set the filter constants to 0 ms.  Recheck the Operation Time edge settings and combination settings in Slaves that support those settings.
	The Operation Time Over Flag is going ON and OFF.	The operation time is compared to the monitoring set value and the Operation Time Over Flag is updated for each measurement. Even if this flag turns ON, it will turn OFF the next time it is updated (i.e., for the next measurement) if the operation time is below the monitoring set value.  All Slaves except for Standard Slaves and Sensor Connector Slaves have flags that hold status when the monitoring set value is exceeded.	---

Model	Details	Probable cause	Remedy
Errors occurring in Slaves with outputs DRT2-OD08(-1) DRT2-OD16(-1) DRT2-MD16(-1) DRT2-ROS16 DRT2-MD16S(-1) DRT2-OD16TA(-1) DRT2-MD16TA(-1) DRT2-OD16ML(X)(-1) DRT2-OD32ML(-1) DRT2-MD32ML(-1) DRT2-OD32B/BV(-1) DRT2-MD32B/BV(-1) DRT2-OD16SL/SLH(-1) DRT2-OD32SL/SLH(-1) DRT2-MD32SL/SLH(-1) DRT2-OD04CL(-1) DRT2-OD08C(-1) DRT2-OD08CL(-1) DRT2-WD16CL(-1) DRT2-MD16CL(-1)	The outputs cannot be held when a communications error has occurred.	The Slave's Output Hold/Clear setting is set to clear outputs when there is a communications error.	Set the Slave's Output Hold/Clear setting to hold outputs when there is a communications error.
	The outputs cannot be cleared when a communications error has occurred.	The Slave's Output Hold/Clear setting is set to hold outputs when there is a communications error.	Set the Slave's Output Hold/Clear setting to clear outputs when there is a communications error.
Errors occurring in Slaves with inputs DRT2-ID08(-1) DRT2-ID16(-1) DRT2-MD16(-1) DRT2-MD16S(-1) DRT2-ID16TA(-1) DRT2-MD16TA(-1) DRT2-ID16ML(X)(-1) DRT2-ID32ML(-1) DRT2-MD32ML(-1) DRT2-ID32B/BV(-1) DRT2-MD32B/BV(-1) DRT2-ID16SL/SLH(-1) DRT2-ID32SL/SLH(-1) DRT2-MD32SL/SLH(-1) DRT2-HD16C(-1) DRT2-ID08C(-1) DRT2-ID04CL(-1) DRT2-ID08CL(-1) DRT2-HD16CL(-1) DRT2-MD16CL(-1)	There is a delay in the input's ON or OFF timing.	An input delay may be set in the input filter function.	Either set the input filter value to 0 or an appropriate non-zero input filter value.
Errors occurring in Slaves equipped with the Sensor Disconnected Detection function DRT2-HD16C(-1) DRT2-ID08C(-1) DRT2-ID16SLH(-1) DRT2-ID32SLH(-1) DRT2-MD32SLH(-1)	The Sensor Disconnected (Off-wire) Detection Flag is going ON for inputs that are not being used.	The Sensor Disconnected Detection function (Off-wire Detection function) may not be disabled for the inputs that are not being used.	Disable the Sensor Disconnected Detection function (Off-wire Detection function) for inputs that are not being used.
Errors occurring in Slaves equipped with the external load short-circuit detection function DRT2-OD08C(-1) DRT2-MD16S(-1) DRT2-OD16SLH(-1)	A short-circuit was corrected after being detected by the external load short-circuit detection function, but the Load Shorted Flag does not go OFF.	The function is set for manual reset. (The default setting is manual reset.)	After correcting the short-circuit, turn the I/O power supply OFF and then ON again.

<b>Model</b>	<b>Details</b>	<b>Probable cause</b>	<b>Remedy</b>
Errors occurring in Slaves equipped with the External Load Disconnected Detection function DRT2-OD16SLH(-1) DRT2-OD32SLH(-1) DRT2-MD32SLH(-1)	The Load Disconnected Flag is going ON for outputs that are not being used.	The Load Disconnected Detection function may not be disabled for the outputs that are not being used.	Disable the Load Disconnected Detection function for outputs that are not being used.
	The Load Disconnected Flag is going ON for an output even though the load is connected.	The load's current consumption is too low. (The minimum output current is 3 mA.)	Disable the Load Disconnected Detection function. (The function cannot detect disconnection of this load.)
	A disconnection was corrected after being detected by the external load disconnected detection function, but the Load Disconnected Flag does not go OFF.	The function is set for manual reset. (The default setting is manual reset.)	After correcting the disconnection, turn the I/O power supply OFF and then ON again.



Model	Details	Probable cause	Remedy
Errors occurring in Analog Slaves	The Flag does not go ON even though the monitor value (threshold) has been exceeded.	The function is not enabled for the Analog Smart Slave. If the monitor value is set to 0, the Flag will always be OFF. The input's decimal point position was in the wrong place when the monitor value was set (DRT2-TS04□ only).	Enable the desired function. Set the monitor value to a non-zero value. Check the decimal point position and enter the monitor value again.
	The expected input value (or analog output value) is not received even after changing the input type, display mode, and units settings.  The function does not operate as expected even after changing data allocated to I/O data and changing the function's Enable Bit.	The new settings will not be reflected without resetting the Slave by turning the power OFF and ON or resetting the Slave from the Configurator.	Either turn the Slave's power OFF and ON or reset the Slave from the Configurator.
	The analog data does not have the expected value or there is a large error in the analog value. A disconnection (off-wire condition) is detected even though the device is connected.	I/O data is not allocated to the function correctly. Scaling is being performed. The connected sensor does not match the input type setting.  There is a large error in the user adjustment settings. The following conditions apply to Temperature Input Terminals only: The setting for the 1/100 display mode/normal display mode is incorrect. The sensor's decimal point position was read incorrectly. The following conditions apply to the DRT2-TS04T only: The Unit is mounted vertically or face-down. The Unit was replaced, but the Terminal Block was not changed. (The accuracy may be reduced if the components are not replaced as a set.)	Check that the analog data format is correct and I/O data is allocated correctly.  If scaling is being performed, check whether the scaling values are correct.  If the scaling function has been enabled inadvertently, disable scaling. Check the input type setting. Perform the user adjustment procedure again. The following remedies apply to Temperature Input Terminals only: In normal display mode, the display value is multiplied by ×1 or ×10, depending on the input type setting. In 1/100 display mode, the display value is multiplied by ×100, regardless of the input type setting. Check the settings and input type again. Check the Unit's mounting direction.
	The DIP switch settings are ineffective.	Pin 8 of the DIP switch is OFF. (This is the default setting.)	Turn ON pin 8.
	The user adjustment and bias compensation settings are not accepted (DRT2-TS04T only).	Adjustment was performed with a input that was outside of the acceptable setting range.	Perform the adjustment procedure again with the correct input voltage (or current). Check the adjustment system and correct if necessary.

Model	Details	Probable cause	Remedy
Errors occurring in Analog Slaves (Input) DRT2-AD04 DRT2-AD04H DRT2-TS04□	The off-wire display will not go away.	The sensor is disconnected. The cold junction compensator has been removed (DRT2-TS04T only). The temperature is far outside of the sensor's measurement temperature range. The input type is incorrect for the temperature being measured.	Fix the sensor disconnection. Check the connected sensor, input type setting, and temperature range.
	The off-wire display will not appear.	With Analog Input Terminals, the off-wire display will not operate if the input is outside of the 1 to 5 V range or 4 to 20 mA range.	---
	The Top/Valley Detection Timing Flag will not go ON. The Top/Valley Count Over Flag will not go ON (DRT2-TS04T only).	The hysteresis setting is too high. The hysteresis setting is 0.	Adjust the hysteresis setting.
	The Top/Valley Detection Timing Flags go ON too frequently. The Top/Valley count is unexpectedly high (DRT2-TS04T only).	The hysteresis setting is too low.	Adjust the hysteresis setting.
Errors occurring in the DRT2-AD04 Analog Input Terminal only	The conversion cycle is too long.	The number of AD conversion points is set to the maximum (4 points). The processing time is longer for each additional function.	If there are unneeded inputs, reduce the number of points. If there are unused functions, delete those functions.
Errors occurring in the DRT2-DA02 Analog Output Terminal only	The expected value is not held when a communications error occurs.	The output hold/clear setting is incorrect.	Check the output hold/clear setting.

Model	Details	Probable cause	Remedy
Errors occurring in the DRT2-TS04□ Temperature Input Terminal only	The 1/100 display mode has been set, but the display reads 0.	The allocated word is a one-word normal display area.	Either change the default connection path to a 1/100 display area or select a connection path in the Master for the 1/100 display area.
	The temperature difference detected by the Data Comparison between Channels function is not rising properly.	A value other than the temperature value is allocated to analog data 2. (The temperature difference display is always a 1/100 display.)	Allocate the temperature value to analog data 2.
	The Zone Counter is not counting even though the temperature value is set as the count condition.	The Comparator function is not enabled as a function type.	Enable the Comparator function. (The power must be turned OFF and then ON again.)
	The Top/Valley Count Over Flag will not go ON (DRT2-TS04T only).	The Top/Valley function is not enabled as a function type. The hysteresis setting is too high. The hysteresis setting is 0.	Enable the Top/Valley function. (The power must be turned OFF and then ON again.) Adjust the hysteresis setting.
	The Comparator function does not operate as expected even though the function and hysteresis value have been set.	The temperature display setting has been switched (°C to °F or vice versa). The decimal point position was read incorrectly.	Check the decimal point position and °C/°F display for the input type and display mode. If these settings have been changed during operation, check the Comparator function and hysteresis settings and correct if necessary.

## 9-3 Maintenance

This section describes the routine cleaning and inspection recommended as regular maintenance. Handling methods when replacing Units are also explained here.

### 9-3-1 Cleaning

Clean the DeviceNet Units regularly as described below in order to keep the Network in its optimal operating condition.

- Wipe the Unit with a dry, soft cloth for regular cleaning.
- When dust or dirt cannot be removed with a dry cloth, dampen the cloth with a neutral cleanser (2%), wring out the cloth, and wipe the Unit.
- Smudges may remain on the Unit from gum, vinyl, or tape that was left on for a long time. Remove these smudges when cleaning.

**Note** Never use volatile solvents such as paint thinner or benzene, or chemical wipes to clean the Unit. These substances may damage the surface of the Unit.

### 9-3-2 Inspection

Inspect the system periodically to keep it in its optimal operating condition.

In general, inspect the system once every 6 to 12 months, but inspect more frequently if the system is used in high-temperature, humid,- or dusty conditions.

**Inspection Equipment**

Prepare the following equipment before inspecting the system.

**Equipment Required for Regular Inspection**

A flat-blade and a Phillips screwdriver, a screwdriver for connecting communications connectors, a tester (or a digital voltmeter), industrial alcohol, and a clean cloth are required for routine inspection.

**Other Equipment that May Be Required**

A synchroscope, oscilloscope, thermometer, or hygrometer may be required.

**Inspection Procedure**

Check the items in the following table and correct any condition that is below standard.

Inspection item	Details	Standard	Equipment
Environmental conditions	Are ambient and cabinet temperatures correct?	Refer to the specifications for each Slave.	Thermometer
	Are ambient and cabinet humidity correct?	Refer to the specifications for each Slave.	Hygrometer
	Has dust or dirt accumulated?	No dust or dirt	Visual inspection
Installation conditions	Are the Units installed securely?	No looseness	Phillips screwdriver
	Are the connectors of the communications cables fully inserted?	No looseness	Phillips screwdriver
	Are the external wiring screws tight?	No looseness	Phillips screwdriver
	Are the connecting cables undamaged?	No external damage	Visual inspection

**9-3-3 Replacing Units**

The Network consists of the DeviceNet Master Unit and Slave Units. The entire network is affected when a Unit is faulty, so a faulty Unit must be repaired or replaced quickly. We recommend having spare Units available to restore Net-work operation as quickly as possible.

**Precautions**

Observe the following precautions when replacing a faulty Unit.

After replacement make sure that there are no errors with the new Unit.

When a Unit is being returned for repair, attach a sheet of paper detailing the problem and return the Unit to your OMRON dealer.

If there is a faulty contact, try wiping the contact with a clean, lint-free cloth dampened with alcohol.

**Settings after Replacing Units**

After replacing a Unit, set the new Unit's switches to the same settings that were on the old Unit.



# Appendix A

## DeviceNet Explicit Messages

DeviceNet explicit messages sent from the Master Unit to a DRT2-series Smart Slave can be used to read or write any parameter of a specified Smart Slave.

The Smart Slaves process the commands sent from the Master and then return responses.

### Basic Format of Explicit Messages

The basic format of each command and response is shown below.

#### Command Block

Destination node address	Service code	Class ID	Instance ID	Attribute ID	Data
--------------------------	--------------	----------	-------------	--------------	------

#### Destination Node Address

The node address of the Unit that is sending the explicit messages (commands) is specified as a single-byte hexadecimal.

#### Service Code, Class ID, Instance ID, Attribute ID

The parameters used for specifying the command, processing object, and processing content.

**Note** The number of bytes designated for Class ID, Instance ID, and Attribute ID depend on the Master Unit. When sent from an OMRON DeviceNet Master, the Class ID and Instance ID are 2 bytes (4 digits), and Attribute ID is 1 byte (2 digits).

#### Data

Data is not required when the read command is used.

### Response Block

#### Normal Response Block

Number of bytes received	Source node address	Service code	Data
--------------------------	---------------------	--------------	------

#### Error Response Block

Number of bytes received: 0004 Hex (fixed)	Source node address	Service code	Error code
---	---------------------	--------------	------------

#### Number of Bytes Received

The number of bytes received from the source node address is returned in hexadecimal. When an error response is returned for an explicit message, the number of bytes is always 0004 Hex.

#### Source Node Address

The node address of the node from which the command was sent is returned in hexadecimal.

## Service Code

For normal completion, the value when the leftmost bit of the service code specified in the command turns ON is stored as shown in the following table.

Function	Command service code	Response service code
Write data	10 Hex	90 Hex
Read data	0E Hex	8E Hex
Reset	05 Hex	85 Hex
Save	16 Hex	96 Hex

When an error response is returned for an explicit message, the value is always 94 Hex.

## Data

Read data is included only when a read command is executed.

## Error Codes

The explicit message error code. For details, refer to the list of error codes in the following table.

### List of Error Codes

Response code	Error name	Cause
08FF	Service not supported	The Service code is incorrect.
09FF	Invalid attribute value	The specified Attribute value is not supported. The data written was outside valid range.
16FF	Object does not exist	The specified Instance ID is not supported.
15FF	Too much data	The data is larger than the specified size.
13FF	Not enough data	The data is smaller than the specified size.
0CFF	Object state conflict	The specified command cannot be executed due to an internal error.
20FF	Invalid parameter	The specified operation command data is not supported.
0EFF	Attribute not settable	An Attribute ID supported only for reading has been executed for a write service code.
10FF	Device state conflict	The specified command cannot be executed due to an internal error.
14FF	Attribute not supported	The specified Attribute is not supported.
19FF	Store operation failure	The data cannot be stored in memory.
2AFF	Group 2 only server general failure	The specified command or Attribute is not supported or the Attribute was not set.

## Explicit Messages Common to All Slaves

### Reading General Status

Explicit message	Read/write	Function	Command					Response
			Service code	Class ID	Instance ID	Command data		
						Attribute ID	Data	
General Status Read	Read	Reads the specified Slave's status flags (8 bits).	0E Hex	95 Hex	01 Hex	65 Hex	---	1 byte

**Note** Refer to 3-2-2 I/O Allocations for Smart Slaves for information on the Generic Status Flags

## Setting and Monitoring the Unit Conduction Time

Explicit message	Read/write	Function	Command					Response
			Service code	Class ID	Instance ID	Command data		
						Attribute ID	Data	
Unit Maintenance Set Value	Read	Reads the set value for Unit Conduction Time (unit: 0.1 hr)	0E Hex	95 Hex	01 Hex	73 Hex	---	4 bytes 00000000 to FFFFFFFF Hex (0 to 4294967295)
	Write	Writes the set value for Unit Conduction Time (unit: 0.1 hr)	10 Hex	95 Hex	01 Hex	73 Hex	4 bytes 00000000 0 to FFFFFFFF F Hex (0 to 4294967 295)	---
Unit Maintenance Present Value	Read	Reads the present value for Unit Conduction Time (unit: 0.1 hr)	0E Hex	95 Hex	01 Hex	71 Hex	---	4 bytes 00000000 to FFFFFFFF Hex (0 to 4294967295)
Unit Maintenance Flag	Read	Reads the monitor status of Unit Conduction Time	0E Hex	95 Hex	01 Hex	72 Hex	---	1 byte 00 Hex: Within range 01 Hex: Out of range (over the monitor value)

## Explicit Messages for General-purpose and Environment-resistant Slaves

### Setting and Monitoring the Terminal (Input)

Explicit message	Read/write	Function	Command					Response
			Service code	Class ID	Instance ID	Command data		
						Attribute ID	Data	
Terminal Maintenance Information Monitor Mode	Read	Reads the monitor mode for maintenance information of the input (No. 1 to 32) specified by the Instance ID.	0E Hex	08 Hex	01 to 20 Hex	65 Hex	---	1 byte 00 Hex: Total ON time mode 01 Hex: Contact operation counter mode
	Write	Writes the monitor mode for maintenance information of the input (No. 1 to 32) specified by the Instance ID.	10 Hex	08 Hex	01 to 20 Hex	65 Hex	1 byte 00 Hex: Total ON time mode 01 Hex: Contact operation counter mode	---



Explicit message	Read/write	Function	Command					Response
			Service code	Class ID	Instance ID	Command data		
						Attribute ID	Data	
Set value (input) for Total ON Time or Contact Operation Counter	Read	Reads the set value for the total ON time (unit: s) or number of contact operations (unit: operations) of the input (No. 1 to 32) specified by the Instance ID.	0E Hex	08 Hex	01 to 20 Hex	68 Hex	---	4 bytes 00000000 to FFFFFFFF Hex (0 to 4294967295)
	Write	Writes the set value for the total ON time (unit: s) or number of contact operations (unit: operations) of the input (No. 1 to 32) specified by the Instance ID.	10 Hex	08 Hex	01 to 20 Hex	68 Hex	4 bytes 00000000 to FFFFFFFF Hex (0 to 4294967295)	---
Total ON Time or Contact Operation Counter (Input) Read	Read	Reads the total ON time (unit: s) or number of contact operations (unit: operations) for the input (No. 1 to 32) specified by the Instance ID.	0E Hex	08 Hex	01 to 20 Hex	66 Hex	---	4 bytes 00000000 to FFFFFFFF Hex (0 to 4294967295)
Total ON Time or Contact Operation Counter (Input) Reset	Reset	Resets the total ON time (unit: s) or number of contact operations (unit: operations) for the input (No. 1 to 32) specified by the Instance ID.	05 Hex	08 Hex	01 to 20 Hex	66 Hex	---	---
Monitor Status for Total ON Time or Contact Operation Counter (Input) Read	Read	Reads the monitor status for total ON time or number of contact operations for the input (No. 1 to 32) specified by the Instance ID.	0E Hex	08 Hex	01 to 20 Hex	67 Hex	---	1 byte 00 Hex: Within range 01 Hex: Out of range (over the monitor value)

### Setting and Monitoring the Terminal (Output)

Explicit message	Read/write	Function	Command					Response
			Service code	Class ID	Instance ID	Command data		
						Attribute ID	Data	
Terminal Maintenance Information Monitor Mode	Read	Reads the monitor mode for maintenance information of the output (No. 1 to 32) specified by the Instance ID.	0E Hex	09 Hex	01 to 20 Hex	65 Hex	---	1 byte 00 Hex: Total ON time mode 01 Hex: Contact operation counter mode
	Write	Writes the monitor mode for maintenance information of the output (No. 1 to 32) specified by the Instance ID.	10 Hex	09 Hex	01 to 20 Hex	65 Hex	1 byte 00 Hex: Total ON time mode 01 Hex: Contact operation counter mode	---

Explicit message	Read /write	Function	Command					Response
			Service code	Class ID	Instance ID	Command data		
						Attribute ID	Data	
Set Value for Total ON Time or Contact Operation Counter (Output)	Read	Reads the set value for the total ON time (unit: s) or number of contact operations (unit: operation) for the output (No. 1 to 32) specified by the Instance ID.	0E Hex	09 Hex	01 to 20 Hex	68 Hex	---	4 bytes 00000000 to FFFFFFFF Hex (0 to 4294967295)
	Write	Writes the set value for the total ON time (unit: s) or number of contact operations (unit: operation) for the output (No. 1 to 32) specified by the Instance ID.	10 Hex	09 Hex	01 to 20 Hex	68 Hex	4 bytes 00000000 to FFFFFFFF Hex (0 to 4294967295)	---
Total ON Time or Contact Operation Counter (Output) Read	Read	Reads the total ON time (unit: s) or number of contact operations (unit: operation) for the output (No. 1 to 32) specified by the Instance ID.	0E Hex	09 Hex	01 to 20 Hex	66 Hex	---	4 bytes 00000000 to FFFFFFFF Hex (0 to 4294967295)
Reset for Total ON Time or Contact Operation Counter (Output) Reset	Reset	Resets the total ON time (unit: s) or number of contact operations (unit: operation) for the output (No. 1 to 32) specified by the Instance ID to 0.	05 Hex	09 Hex	01 to 20 Hex	66 Hex	---	---
Monitor Status for Total ON Time or Contact Operation Counter (Output) Read	Read	Reads the monitor status for total ON time or contact operation counter for the output (No. 1 to 32) specified by the Instance ID.	0E Hex	09 Hex	01 to 20 Hex	67 Hex	---	1 byte 00 Hex: Within range 01 Hex: Out of range (over the monitor value)

## Setting and Monitoring Operation Time

### Basic I/O Unit + Expansion Unit/Sensor Connector I/O Terminal

Explicit message	Read /write	Function	Command					Response
			Service code	Class ID	Instance ID	Command data		
						Attribute ID	Data	
Set Value for Operation Time Monitor	Read	Reads the monitor value for the time (unit: ms) an output (No. 1 to 16) specified by the Instance ID turns ON until the corresponding input turns ON.	0E Hex	97 Hex	01 to 10 Hex	67 Hex	---	2 bytes 0000 to FFFF Hex (0 to 65535)
	Write	Writes the monitor value for the time (unit: ms) an output (No. 1 to 16) specified by the Instance ID turns ON until the corresponding input turns ON.	10 Hex	97 Hex	01 to 10 Hex	67 Hex	2 bytes 0000 to FFFF Hex (0 to 65535)	---

Explicit message	Read /write	Function	Command					Response
			Service code	Class ID	Instance ID	Command data		
						Attribute ID	Data	
Present Value for Operation Time Monitor	Read	Reads the present value for the time (unit: ms) an output (No. 1 to 16) specified by the Instance ID turns ON until the corresponding input turns ON.	0E Hex	97 Hex	01 to 10 Hex	65 Hex	---	2 bytes 0000 to FFFF Hex (0 to 65535)
Monitor Status Value for Operation Time Monitor Read	Read	Reads the monitor status for the time (unit: ms) an output (No. 1 to 16) specified by the Instance ID turns ON until the corresponding input turns ON.	0E Hex	97 Hex	01 to 10 Hex	66 Hex	---	1 byte 00 Hex: Within range 01 Hex: Out of range (over the monitor value)

**Three-tier Terminal Block Terminal, MIL Connector Terminal, Board Terminal, and Screw-less Clamp Terminal**

Explicit message	Read /write	Function	Command					Response
			Service code	Class ID	Instance ID	Command data		
						Attribute ID	Data	
Operation Time Monitor Peak Value Read	Read	Reads the peak value for the time (unit: ms) from the start point trigger until the end point trigger specified by the Instance ID (No. 1 to 8).	0E Hex	97 Hex	01 to 08 Hex	68 Hex	---	2 bytes 0000 to FFFF Hex (0 to 65535)
Operation Time Monitor Peak Value Reset	Reset	Resets to the present value the peak value for the time (unit: ms) from the start point trigger until the end point trigger specified by the Instance ID (No. 1 to 8)	05 Hex	97 Hex	01 to 08 Hex	68 Hex	---	---
Operation Time Monitor History	Read	Reads the monitor history for the time (unit: ms) from the start point trigger until the end point trigger specified by the Instance ID (No. 1 to 8).	0E Hex	97 Hex	01 to 08 Hex	6D Hex	---	1 byte 00 Hex: Value not exceeded 01 Hex: Value exceeded
Operation Time Monitor History Reset	Read	Resets the monitor history for the time (unit: ms) from the start point trigger until the end point trigger specified by the Instance ID (No. 1 to 8) to 0.	05 Hex	97 Hex	01 to 08 Hex	6D Hex	---	---

## Setting Hold/Clear for Communications Errors (Output)

Explicit message	Read /write	Function	Command					Response
			Service code	Class ID	Instance ID	Command data		
						Attribute ID	Data	
Setting for Output Status (Hold or Clear) after Communications Error	Read	Reads whether hold or clear is set as the output status after a communications error for an output (No. 1 to 32) specified by the Instance ID. The setting can be read for a specified number of points.	0E Hex	09 Hex	01 to 20 Hex	05 Hex	---	1 byte 00 Hex: Clear 01 Hex: Hold
Setting for Output Status (Hold or Clear) after Communications Error	Write	Sets whether hold or clear is set as the output status after a communications error for an output (No. 1 to 32) specified by the Instance ID. The setting can be set for a specified number of points.	10 Hex	09 Hex	01 to 20 Hex	05 Hex	1 byte 00 Hex: Clear 01 Hex: Hold	---

**Note** The default setting is for all outputs to be cleared (0).

## Setting and Monitoring Detection of Sensor Power Short-circuit

Explicit message	Read/write	Function	Command					Response
			Service code	Class ID	Instance ID	Command data		
						Attribute ID	Data	
Sensor Power Short-circuit Status (Environment-resistive Terminal Input Units, Screw-less Clamp Input and I/O Units only)	Read	Reads the short-circuit status of sensor power for the input (No. 1 to 32) specified by the Instance ID. <b>Note:</b> For DRT2-HD16C(-1), the same information is read for the two inputs in the same connector.	0E Hex	08 Hex	01 to 20 Hex	69 Hex	---	1 byte 00 Hex: Operating normally 01 Hex: Shorted
Sensor Power Short-circuit Status (Sensor Connector Terminals only)	Read	Reads the short-circuit status of sensor power.	0E Hex	95 Hex	01 Hex	7D Hex	---	1 byte 00 Hex: Operating normally 01 Hex: Shorted
Sensor Power Short-circuit Status for All Sensors Read at Once (Environment-resistive Terminal Input Units, Screw-less Clamp Input and I/O Units only)	Read	Reads the short-circuit status of sensor power for all sensors. <b>Note:</b> For DRT2-HD16C(-1), reads the status for each input connector.	0E Hex	1D Hex	01 Hex	67 Hex	---	1 byte, 2 bytes, 4 bytes 00 Hex: Operating normally Other values: The sensor power has shorted for the corresponding terminal (connector 1 to 32: bit 00 to 31). (See note.)

**Note** Response data size: 1 byte for Environment-resistive Terminals, 2 bytes for 16-input Clamp Terminals, and 4 bytes for 32-input Clamp Terminals.

### Setting and Monitoring Sensor Disconnected Detection

Explicit message	Read/write	Function	Command					Response
			Service code	Class ID	Instance ID	Command data		
						Attribute ID	Data	
Sensor Disconnected Setting (Environment-resistive Terminal Input Units, Screw-less Clamp Input and I/O Units only)	Read	Reads the setting status for sensor disconnection for the input (No. 1 to 32) specified by the Instance ID. <b>Note:</b> For DRT2-HD16C(-1), the same setting is used for the two inputs in the same connector.	0E Hex	08 Hex	01 to 20 Hex	68 Hex	---	1 byte 00 Hex: Disabled (not used) 01 Hex: Enabled (used)
	Write	Writes the setting for the sensor detection for the input (No. 1 to 32) specified by the Instance ID. <b>Note:</b> For DRT2-HD16C(-1), the same setting is used for the two inputs in the same connector. For example, input 0 and input 1 share the same setting. If input 0 and input 1 are assigned different settings, the last input setting will be used for both inputs.	10 Hex	08 Hex	01 to 20 Hex	68 Hex	1 byte 00 Hex: Disabled (not used) 01 Hex: Enabled (used)	---
Sensor Disconnected Status Read (Environment-resistive Terminal Input Units, Screw-less Clamp Input and I/O Units only)	Read	Reads the sensor connected/disconnected status for the input (No. 1 to 32) specified by the Instance ID. <b>Note:</b> For DRT2-HD16C(-1), the same information is read for the two inputs in the same connector.	0E Hex	08 Hex	01 to 20 Hex	6A Hex	---	1 byte 00 Hex: Connected (or no detection setting) 01 Hex: Disconnected
Sensor Disconnected Status for All Sensors Read at Once (Environment-resistive Terminal Input Units, Screw-less Clamp Input and I/O Units only)	Read	Reads the sensor connected/disconnected status for all sensors at once. <b>Note:</b> For DRT2-HD16C(-1), reads the status for each input connector.	0E Hex	1D Hex	01 Hex	68 Hex	---	1 byte, 2 bytes, 4 bytes 00 Hex: Operating normally Other values: The sensor of the corresponding input connector is disconnected (connectors 1 to 32: bits 00 to 31) (See note.)

**Note** Response data size: 1 byte for Environment-resistive Terminals, 2 bytes for 16-input Clamp Terminals, and 4 bytes for 32-input Clamp Terminals.

## Monitoring External Load Short-circuit Detection

Explicit message	Read/write	Function	Command				Response	
			Service code	Class ID	Instance ID	Command data		
						Attribute ID		Data
External Load Short-circuit Detection Status (Environment-resistive Terminal Output Units only)	Read	Reads the external load short-circuit status of the output (No. 1 to 8) specified by the Instance ID.	0E Hex	09 Hex	01 to 08 Hex	69 Hex	---	1 byte 00 Hex: Operating normally 01 Hex: Shorted
External Load Short-circuit Detection Status (Sensor Connector Terminal I/O Units only)	Read	Reads the external load short-circuit status for Sensor Connector Terminals.	01 Hex	95 Hex	01 Hex	7D Hex	---	1 byte 00 Hex: Error 10 Hex: Shorted
External Load Short-circuit Detection Status for All Outputs Read at Once (Environment-resistive Terminal Output Units only)	Read	Reads the load short-circuit status for all outputs at once.	0E Hex	1E Hex	01 Hex	64 Hex	---	1 byte, 2 bytes 00 Hex: Operating normally Other values: Load shorted for corresponding terminal (outputs 0 to 15: bits 0 to 15)

**Note** Response data size: 1 byte for Environment-resistive Terminals, and 2 bytes for Screw-less Clamp Terminals.

## External Load Disconnected Detection Monitoring

Explicit message	Read/write	Function	Command					Response
			Service code	Class ID	Instance ID	Command data		
						Attribute ID	Data	
External Load Disconnected Detection Status (Screw-less Clamp Terminal Output and I/O Units only)	Read	Reads the external load disconnection status of the output (No. 1 to 32) specified by the Instance ID.	0E Hex	09 Hex	01 to 20 Hex	6A Hex	---	2 bytes, 4 bytes 00 Hex: Operating normally 01 Hex: Disconnected
External Load Disconnected Detection Status for All Outputs at Once (Screw-less Clamp Terminal Output and I/O Units only)	Read	Reads the external load disconnection status for all outputs at once.	0E Hex	1E Hex	01 Hex	68 Hex	---	2 bytes, 4 bytes 00 Hex: Operating normally Other values: Load disconnected for corresponding terminal (outputs 0 to 31: bits 0 to 31)

**Note** Response data size: 2 bytes for 16-output Clamp Terminals, and 4 bytes for 32-output Clamp Terminals.

## Writing Maintenance Information

Explicit message	Read/write	Function	Command					Response
			Service code	Class ID	Instance ID	Command data		
						Attribute ID	Data	
Maintenance Counter Save	Save	Records the maintenance counter in the Slave's memory.	16 Hex	95 Hex	01 Hex	75 Hex	---	---



### Reading Operation Time Monitor and Total ON Time/Contact Operation Counter for All Slaves at Once

Explicit message	Read /write	Function	Command					Response
			Service code	Class ID	Instance ID	Command data		
						Attribute ID	Data	
Monitor Status for Operation Time Monitor for All Slaves Read at Once	Read	Reads the monitor status for total operation time monitor for all Slaves.	0E Hex	95 Hex	01 Hex	7E Hex	---	+00: Response size +01: 02 Hex (fixed) +02: Response area 1 +03: Response area 2 (See note 1.)
Monitor Status for Total ON Time or Contact Operation Counter for All Slaves Read at Once	Read	Reads the monitor status for total ON time or contact operation counter for all Slaves.	0E Hex	95 Hex	01 Hex	7F Hex	---	+00: Response size +01: 02 Hex (fixed) +02: Response area 1 +03: Response area 2 +04: Response area 3 +05: Response area 4 +06: Response area 5 +07: Response area 6 +08: Response area 7 +09: Response area 8 (See note 2.)

**Note 1.** The Attribute (7E Hex) is bit 6 of the Generic Status and so the size is fixed at 4 bytes and has the following format.

+00	Size, 0002	Fixed
+01		
+02	IN+OUT combined, terminals 0 to 7	The bit turns ON when the set value is exceeded.
+03	IN+OUT combined, terminals 8 to 15	

**Note**

- Depending on the Unit size, not all bits are used.
- 14FF is returned for all Units except mixed I/O Units.

2. The Attribute (7F Hex) is bit 7 of the Generic Status and so the size is fixed at 10 bytes and has the following format.

+00	Size, 0008	Fixed
+01		
+02	IN Area, terminals 0 to 7	
+03	IN Area, terminals 8 to 15	
+04	IN Area, terminals 16 to 24	
+05	IN Area, terminals 25 to 31	
+06	OUT Area, terminals 0 to 7	
+07	OUT Area, terminals 8 to 15	
+08	OUT Area, terminals 16 to 24	
+09	OUT Area, terminals 25 to 31	

**Note** Depending on the Unit size, not all bits are used.

## Explicit Messages for Analog Slaves

### Reading DIP Switch Settings

Explicit message	Read /write	Function	Command					Response
			Service code	Class ID	Instance ID	Command data		
						Attribute ID	Data	
DIP Switch Status Read	Read	Reads the status of the Input/Output Terminals DIP switch.	0E Hex	94 Hex	01 Hex	68 Hex	---	1 byte

### Setting and Reading for Analog Input Terminals

Explicit message	Read /write	Function	Command					Response
			Service code	Class ID	Instance ID	Command data		
						Attribute ID	Data	
Analog Data 1 Value	Read	Reads the value for Analog Data 1.	0E Hex	0A Hex	01 to 04 Hex	03 Hex	---	2 byte
Analog Data 2 Value	Read	Reads the value for Analog Data 2.	0E Hex	0A Hex	01 to 04 Hex	65 Hex	---	2 bytes
Number of AD Conversion Points Setting	Write/Read	Sets the number of AD conversion points.	Write: 10 Hex Read: 0E Hex	0A Hex	00 Hex	64 Hex	2 bytes	1 byte
Input Range Setting	Write/Read	Sets the input range. -10 to 10 V: 0 0 to 5 V: 1 0 to 10 V: 2 4 to 20 mA: 3 1 to 5 V: 7 0 to 20 mA: 8	Write: 10 Hex Read: 0E Hex	0A Hex	01 to 04 Hex	04 Hex	1 byte	1 byte
Analog Status Flag Read	Read	Reads the status of the Analog Status Flags. LL = 0; L = 1; Pass signal = 2; H = 3; HH = 4; Valley shot = 5; Top shot = 6; Off-wire detection = 7	0E Hex	0A Hex	01 to 04 Hex	66 Hex	---	1 byte

Explicit message	Read /write	Function	Command					Response
			Service code	Class ID	Instance ID	Command data		
						Attribute ID	Data	
Analog Data 1 Allocation Selection	Write/Read	Selects the data allocated to Analog Data 1. Analog input value: 0; Peak value: 1; Bottom value: 2; Top value: 3; Valley value: 4; Rate of change value: 5	Write: 10 Hex Read: 0E Hex	0A Hex	01 to 04 Hex	68 Hex	1 byte	1 byte
Analog Data 2 Allocation Selection	Write/Read	Selects the data allocated to Analog Data 2. Analog input value: 0; Peak value: 1; Bottom value: 2; Top value: 3; Valley value: 4; Rate of change value: 5	Write: 10 Hex Read: 0E Hex	0A Hex	01 to 04 Hex	69 Hex	1 byte	1 byte
Function Setting	Write/Read	Sets each function. Bit status: ON: Enabled, OFF: Disabled Moving average: 0; Scaling: 1; Peak/bottom hold: 2; Top/valley hold: 3; Comparator: 4; Cumulative counter: 5; Rate of change: 6	Write: 10 Hex Read: 0E Hex	0A Hex	01 to 04 Hex	6E Hex	1 byte	1 byte
Scaling Type Setting	Write/Read	Default scaling: 0; User scaling: 1	Write: 10 Hex Read: 0E Hex	0A Hex	01 to 04 Hex	6F Hex	1 byte	1 byte
Scaling Point 1 Setting	Write/Read	Sets an analog value as the 0% value for user scaling.	Write: 10 Hex Read: 0E Hex	0A Hex	01 to 04 Hex	70 Hex	2 bytes (-28000 to 28000)	2 bytes (-28000 to 28000)
Scaling Point 2 Setting	Write/Read	Sets an analog value as the 100% value for user scaling.	Write: 10 Hex Read: 0E Hex	0A Hex	01 to 04 Hex	71 Hex	2 bytes (-28000 to 28000)	2 bytes (-28000 to 28000)
Offset Compensation	Write/Read	Compensates for scaling errors with an offset value.	Write: 10 Hex Read: 0E Hex	0A Hex	01 to 04 Hex	72 Hex	2 bytes (-28000 to 28000)	2 bytes (-28000 to 28000)
Maximum Value Read	Read/Reset	Reads the maximum value after power is turned ON.	Read: 0E Hex Reset: 35 Hex	0A Hex	01 to 04 Hex	73 Hex	---	2 bytes
Minimum Value Read	Read/Reset	Reads the minimum value after power is turned ON.	Read: 0E Hex Reset: 35 Hex	0A Hex	01 to 04 Hex	74 Hex	---	2 bytes
Peak Value Read	Read	The peak value is held and read.	0E Hex	0A Hex	01 to 04 Hex	75 Hex	---	2 bytes
Bottom Value Read	Read	The bottom value is held and read.	0E Hex	0A Hex	01 to 04 Hex	76 Hex	---	2 bytes

Explicit message	Read /write	Function	Command					Response
			Service code	Class ID	Instance ID	Command data		
						Attribute ID	Data	
Top Value Read	Read	The top value is held and read.	0E Hex	0A Hex	01 to 04 Hex	77 Hex	---	2 bytes
Top Detection Timing Flag Read	Read	Reads the timing for detecting top values.	0E Hex	0A Hex	01 to 04 Hex	78 Hex	---	1 byte
Valley Value Read	Read	The valley value is held and read.	0E Hex	0A Hex	01 to 04 Hex	79 Hex	---	2 bytes
Valley Detection Timing Flag Read	Read	Reads the timing for detecting valley values.	0E Hex	0A Hex	01 to 04 Hex	7A Hex	---	1 byte
HH Value Setting	Write/Read	Sets the HH value.	Write: 10 Hex Read: 0E Hex	0A Hex	01 to 04 Hex	7D Hex	2 bytes (-32768 to 32767)	2 bytes (-32768 to 32767)
LL Value Setting	Write/Read	Sets the LL value.	Write: 10 Hex Read: 0E Hex	0A Hex	01 to 04 Hex	7E Hex	2 bytes (-32768 to 32767)	2 bytes (-32768 to 32767)
H Value Setting	Write/Read	Sets the H value.	Write: 10 Hex Read: 0E Hex	0A Hex	01 to 04 Hex	7F Hex	2 bytes (-32768 to 32767)	2 bytes (-32768 to 32767)
L Value Setting	Write/Read	Sets the L value.	Write: 10 Hex Read: 0E Hex	0A Hex	01 to 04 Hex	80 Hex	2 bytes (-32768 to 32767)	2 bytes (-32768 to 32767)
Scaled Analog Input Value Read	Read	Reads analog input values for which have only been scaled.	0E Hex	0A Hex	01 to 04 Hex	8D Hex	---	2 bytes
Rate of Change Value Read	Read	Reads the rate of change for each sampling cycle.	0E Hex	0A Hex	01 to 04 Hex	8E Hex	---	2 bytes
Sampling Cycle Setting	Write/Read	Sets the sampling cycle for obtaining the rate of change based on the previous value.	Write: 10 Hex Read: 0E Hex	0A Hex	01 to 04 Hex	90 Hex	DRT2-AD04: 2 bytes (10 to 65535) DRT2-AD04H: 2 bytes (250 to 65500)	DRT2-AD04: 2 bytes (10 to 65535) DRT2-AD04H: 2 bytes (250 to 65500)
Cumulated Value Read	Read/Reset	Reads the cumulated analog input value.	Read: 0E Hex Reset: 35 Hex	0A Hex	01 to 04 Hex	91 Hex	---	4 bytes (-214748364.8 to 214748364.7)
Cumulative Counter Flag Read	Read	Reads the cumulative count status in the Cumulative Counter Flag in the area for Generic Status Flags. 0: Counter overflow 1: Counter underflow 7: Set value overflow	Read: 0E Hex	0A Hex	01 to 04 Hex	92 Hex	---	1 byte

Explicit message	Read /write	Function	Command					Response
			Service code	Class ID	Instance ID	Command data		
						Attribute ID	Data	
Cumulative Counter Monitor Value Setting	Write/Read	Writes/reads the set monitor value for the cumulative counter.	Write: 10 Hex Read: 0E Hex	0A Hex	01 to 04 Hex	93 Hex	4 bytes	4 bytes
Cumulative Counter Unit Setting	Write/Read	Sets the unit for the cumulative counter. 0: Hour (count hours); 1: Minute (count minutes)	Write: 10 Hex Read: 0E Hex	0A Hex	01 to 04 Hex	94 Hex	1 byte	1 byte

## Setting and Reading for Analog Output Terminals

Explicit message	Read /write	Function	Command					Response
			Service code	Class ID	Instance ID	Command data		
						Attribute ID	Data	
Analog Output Value Read	Read	Reads analog output values.	0E Hex	0B Hex	01 to 02 Hex	03 Hex	---	2 bytes
Output Range Setting	Write/Read	Sets the output range. 4 to 20 mA: 0; 0 to 10 V: 1; 0 to 20 mA: 2; -10 to 10 V: 3; 0 to 5 V: 4; 1 to 5 V: 6	0E Hex	0B Hex	01 to 02 Hex	07 Hex	---	1 byte
Communications Error Output Setting	Write/Read	Sets the communications error output value for each output. 0: Hold last state 1: Low limit 2: High limit 3: Zero count	Write: 10 Hex Read: 0E Hex	0B Hex	01 to 02 Hex	09 Hex	1 byte	1 byte
Function Setting	Write/Read	Sets the function. Scaling: 0; Cumulative counter: 1	Write: 10 Hex Read: 0E Hex	0B Hex	01 to 02 Hex	6E Hex	1 byte	1 byte
Scaling Type Setting	Write/Read	Default scaling: 0; User scaling: 1	Write: 10 Hex Read: 0E Hex	0B Hex	01 to 02 Hex	6F Hex	1 byte	---
Scaling Point 1 Setting	Write/Read	Sets a conversion value as the 0% value for user scaling.	Write: 10 Hex Read: 0E Hex	0B Hex	01 to 02 Hex	70 Hex	---	---
Scaling Point 2 Setting	Write/Read	Sets a conversion value as the 100% value for user scaling.	Write: 10 Hex Read: 0E Hex	0B Hex	01 to 02 Hex	71 Hex	---	---
Offset Compensation	Write/Read	Compensates for scaling errors with an offset value.	Write: 10 Hex Read: 0E Hex	0B Hex	01 to 02 Hex	72 Hex	2 bytes (-28000 to 28000)	2 bytes (-28000 to 28000)

Explicit message	Read /write	Function	Command					Response
			Service code	Class ID	Instance ID	Command data		
						Attribute ID	Data	
Cumulated Value Read	Read/Reset	Reads the cumulated analog output value.	Read: 0E Hex Reset: 35 Hex	0B Hex	01 to 02 Hex	91 Hex	---	4 bytes (-214748364.8 to 214748364.8)
Cumulative Counter Flag Read	Read	Reads the cumulative count status in the Cumulative Counter Flag in the area for Generic Status Flags. 0: Counter overflow 1: Counter underflow 7: Set value overflow	Read: 0E Hex	0B Hex	01 to 02 Hex	92 Hex	---	1 byte
Cumulative Counter Monitor Value Setting	Write/Read	Writes/reads the set monitor value for the cumulative counter.	Write: 10 Hex Read: 0E Hex	0B Hex	01 to 02 Hex	93 Hex	4 bytes	4 bytes
Cumulative Counter Unit Setting	Write/Read	Sets the unit for the cumulative counter. 0: Hour (count hours); 1: Minute (count minutes)	Write: 10 Hex Read: 0E Hex	0B Hex	01 to 02 Hex	94 Hex	1 byte	---

### Setting and Reading for Temperature Input Terminals

Explicit message	Read /write	Function	Command					Response
			Service code	Class ID	Instance ID	Command data		
						Attribute ID	Data	
Display Format Read (Normal or 1/100)	Read	Reads the display format. Normal display: 1 1/100 display: 2	0E Hex	31 Hex	00 Hex	64 Hex	---	1 byte
Temperature 1 Read for Normal Display	Read	Reads the value of temperature data 1.	0E Hex	31 Hex	01 to 04 Hex	A5 Hex	---	2 bytes
Temperature 2 Read for Normal Display	Read	Reads the value of temperature data 2.	0E Hex	31 Hex	01 to 04 Hex	A6 Hex	---	2 bytes
Temperature 1 Read for 1/100 Display	Read	Reads the value of temperature data 1.	0E Hex	31 Hex	01 to 04 Hex	A6 Hex	---	4 bytes
Temperature 2 Read for 1/100 Display	Read	Reads the value of temperature data 2.	0E Hex	31 Hex	01 to 04 Hex	65 Hex	---	4 bytes
Input Type Set	Write/Read	Sets the input type. R: 0, S: 1, K1: 2, K2: 3, J1: 4, J2: 5, T: 6, E: 7, L1: 8, L2: 9, U: A, N: B, W: C, B: D, PL2: E, PT: F, JPT: 10, PT2: 11, JPT: 12	Write: 10 Hex Read: 0E Hex	31 Hex	01 to 04 Hex	A2 Hex	1 byte	1 byte

Explicit message	Read /write	Function	Command					Response
			Service code	Class ID	Instance ID	Command data		
						Attribute ID	Data	
User Adjustment Check	Read	Checks to see if user adjustment has been performed for the temperature conversion constant. User adjustment: 1 Default setting: 0	0E Hex	31 Hex	1 to 4 Hex	84 Hex	---	1 byte
Display Unit Read	Read	Reads the display unit. °C: 1200, °F: 1201	0E Hex	31 Hex	01 to 04 Hex	04 Hex	---	2 bytes
Analog Status Flag Read	Read	Reads the status of the Analog Status Flags. LL = 0; L = 1; Pass signal = 2; H = 3; HH = 4; Valley shot = 5; Top shot = 6; Off-wire detection = 7	0E Hex	31 Hex	01 to 04 Hex	66 Hex	---	1 byte
Temperature Data 1 Allocation Selection	Write/Read	Selects the data allocated to Temperature Data 1. Temperature input value: 0; Peak value: 1; Bottom value: 2; Top value: 3; Valley value: 4; Rate of change value: 5	Write: 10 Hex Read: 0E Hex	31 Hex	01 to 04 Hex	68 Hex	1 byte	1 byte
Temperature Data 2 Allocation Selection	Write/Read	Selects the data allocated to Temperature Data 2. Temperature input value: 0; Peak value: 1; Bottom value: 2; Top value: 3; Valley value: 4; Rate of change value: 5	Write: 10 Hex Read: 0E Hex	31 Hex	01 to 04 Hex	69 Hex	1 byte	1 byte
Function Setting	Write/Read	Sets each function. Bit status: ON: Enabled, OFF: Disabled Moving average: 0; Scaling: 1; Peak/bottom hold: 2; Top/valley hold: 3; Comparator: 4; Cumulative counter: 5; Rate of change: 6	Write: 10 Hex Read: 0E Hex	31 Hex	01 to 04 Hex	6E Hex	2 bytes	2 bytes
Scaling Point 1 Setting	Write/Read	Sets an temperature value as the 0% value for user scaling.	Write: 10 Hex Read: 0E Hex	31 Hex	01 to 04 Hex	70 Hex	2 bytes	2 bytes
Scaling Point 2 Setting	Write/Read	Sets an temperature value as the 100% value for user scaling.	Write: 10 Hex Read: 0E Hex	31 Hex	01 to 04 Hex	71 Hex	2 bytes	2 bytes

Explicit message	Read /write	Function	Command					Response
			Service code	Class ID	Instance ID	Command data		
						Attribute ID	Data	
Offset Compensation	Write/Read	Compensates for scaling errors with an offset value.	Write: 10 Hex Read: 0E Hex	31 Hex	01 to 04 Hex	72 Hex	2 bytes	2 bytes
Maximum Value Read	Read/Reset	Reads the maximum value after power is turned ON.	Read: 0E Hex Reset: 35 Hex	31 Hex	01 to 04 Hex	73 Hex	---	4 bytes
Minimum Value Read	Read/Reset	Reads the minimum value after power is turned ON.	Read: 0E Hex Reset: 35 Hex	31 Hex	01 to 04 Hex	74 Hex	---	4 bytes
Peak Value Read	Read	The peak value is held and read.	0E Hex	31 Hex	01 to 04 Hex	75 Hex	---	4 bytes
Bottom Value Read	Read	The bottom value is held and read.	0E Hex	31 Hex	01 to 04 Hex	76 Hex	---	4 bytes
Top Value Read	Read	The top value is held and read.	0E Hex	31 Hex	01 to 04 Hex	77 Hex	---	4 bytes
Top Detection Timing Flag Read	Read	Reads the timing for detecting top values.	0E Hex	31 Hex	01 to 04 Hex	78 Hex	---	1 byte
Valley Value Read	Read	The valley value is held and read.	0E Hex	31 Hex	01 to 04 Hex	79 Hex	---	4 bytes
Valley Detection Timing Flag Read	Read	Reads the timing for detecting valley values.	0E Hex	31 Hex	01 to 04 Hex	7A Hex	---	1 byte
HH Value Setting	Write/Read	Sets the HH value.	Write: 10 Hex Read: 0E Hex	31 Hex	01 to 04 Hex	11 Hex	4 bytes (-415000 to 415000)	4 bytes (-415000 to 415000)
LL Value Setting	Write/Read	Sets the LL value.	Write: 10 Hex Read: 0E Hex	31 Hex	01 to 04 Hex	12 Hex	4 bytes (-415000 to 415000)	4 bytes (-415000 to 415000)
H Value Setting	Write/Read	Sets the H value.	Write: 10 Hex Read: 0E Hex	31 Hex	01 to 04 Hex	15 Hex	4 bytes (-415000 to 415000)	4 bytes (-415000 to 415000)
L Value Setting	Write/Read	Sets the L value.	Write: 10 Hex Read: 0E Hex	31 Hex	01 to 04 Hex	16 Hex	4 bytes (-415000 to 415000)	4 bytes (-415000 to 415000)
Scaled Temperature Input Value Read	Read	Reads temperature input values for which have only been scaled.	0E Hex	31 Hex	01 to 04 Hex	8D Hex	---	4 bytes (-415000 to 415000)
Rate of Change Value Read	Read	Reads the rate of change for each sampling cycle.	0E Hex	31 Hex	01 to 04 Hex	8E Hex	---	4 bytes (-415000 to 415000)



Explicit message	Read /write	Function	Command					Response
			Service code	Class ID	Instance ID	Command data		
						Attribute ID	Data	
Sampling Cycle Setting	Write/Read	Sets the sampling cycle for obtaining the rate of change based on the previous value. Set in multiples of 250 ms. (Default: 250 ms)	Write: 10 Hex Read: 0E Hex	31 Hex	01 to 04 Hex	90 Hex	2 bytes (250 to 65550)	2 bytes (250 to 65550)
Cumulated Value Read	Read/Reset	Reads the cumulated temperature input value.	Read: 0E Hex Reset: 35 Hex	31 Hex	01 to 04 Hex	91 Hex	---	4 bytes (-214748364.8 to 214748364.7)
Cumulative Counter Flag Read	Read	Reads the cumulative count status in the Cumulative Counter Flag in the area for Generic Status Flags. 0: Counter overflow 1: Counter underflow 7: Set value overflow	0E Hex	31 Hex	01 to 04 Hex	92 Hex	---	1 byte
Cumulative Counter Monitor Value Setting	Write/Read	Writes/reads the set monitor value for the cumulative counter.	Write: 10 Hex Read: 0E Hex	31 Hex	01 to 04 Hex	93 Hex	4 bytes	4 bytes
Cumulative Counter Unit Setting	Write/Read	Sets the unit for the cumulative counter. 0: Hour (count hours); 1: Minute (count minutes)	Write: 10 Hex Read: 0E Hex	31 Hex	01 to 04 Hex	94 Hex	1 byte	1 byte
Decimal Position Read	Read	Reads the position of the decimal point. 0000 = 0 0000.0 = 1 0000.00 = 2	0E Hex	31 Hex	01 to 04 Hex	A3 Hex	---	1 byte
Top/Valley Count Read	Read/Reset	Reads the number of tops or valleys that have been counted.	Read: 0E Hex Reset: 35 Hex	31 Hex	01 to 04 Hex	A9 Hex	---	4 bytes
Top/Valley Count Threshold Status Read	Read	Reads whether the top/valley count has exceeded the threshold value. 0: Counter overflow 1: Counter underflow 7: Set value overflow	0E Hex	31 Hex	01 to 04 Hex	AA Hex	---	1 byte
Top/Valley Counting Selection	Write/Read	Selects counting either tops or valleys. Count tops = 0 Count valleys = 1	Write: 10 Hex Read: 0E Hex	31 Hex	01 to 04 Hex	AB Hex	1 byte	1 byte
Top/Valley Count Threshold Set	Write/Read	Sets the threshold value to compare with the top/valley count.	Write: 10 Hex Read: 0E Hex	31 Hex	01 to 04 Hex	AC Hex	4 bytes	4 bytes

Explicit message	Read /write	Function	Command					Response
			Service code	Class ID	Instance ID	Command data		
						Attribute ID	Data	
Time in Temperature Range Read	Read/Reset	Reads (in seconds) the time the system has been in a user-set temperature range.	Read: 0E Hex Reset: 35 Hex	31 Hex	01 to 04 Hex	AD Hex	4 bytes	4 bytes
Threshold Status for Time in Temperature Range Read	Read	Compares the time the system has been in a user-set temperature range with a threshold value. 0: Timer overflow 1: Timer underflow 7: Set value overflow	0E Hex	31 Hex	01 to 04 Hex	AE Hex	---	1 byte
Range for Time in Temperature Range Set	Write/Read	Sets the range for timing the time in the set temperature range. Above HH = 0, Between HH and H = 1, Pass = 2, Between L and LL = 3, Below LL = 4	Write: 10 Hex Read: 0E Hex	31 Hex	01 to 04 Hex	AF Hex	1 byte	1 byte
Threshold for Comparison with Time in Temperature Range Set/Read	Write/Read	Sets (in seconds) the threshold value that is compared to the time in the user-set temperature range.	Write: 10 Hex Read: 0E Hex	31 Hex	01 to 04 Hex	B0 Hex	4 bytes	4 bytes
Input Temperature Variation Detection Read	Read	Reads the result of input temperature variation detection.	0E Hex	69 Hex	01 to 06 Hex	67 Hex	---	4 bytes
Input Temperature Variation Detection Threshold Compare	Read	Compares the input temperature variation detection result with a threshold value and outputs the result. 0: Counter overflow 1: Counter underflow 6: Invalid data 7: Set value overflow	0E Hex	69 Hex	01 to 06 Hex	68 Hex	---	1 byte
Input Temperature Variation Detection Threshold Set	Write/Read	Sets the threshold for comparison with the input temperature variation detection result.	Write: 10 Hex Read: 0E Hex	69 Hex	01 to 06 Hex	6E Hex	4 bytes	4 bytes

## Using Explicit Messages

The following example shows how to use explicit messages with Smart Slaves using a CS1W-DRM21 DeviceNet Unit (Master).

Example: Reading the monitor status for the operation time monitor.

**Example Conditions DeviceNet Unit node address: 05**

**Unit number: 0**

**Unit address: FE Hex (or 10 Hex)**

**Smart Slave node address: 11**

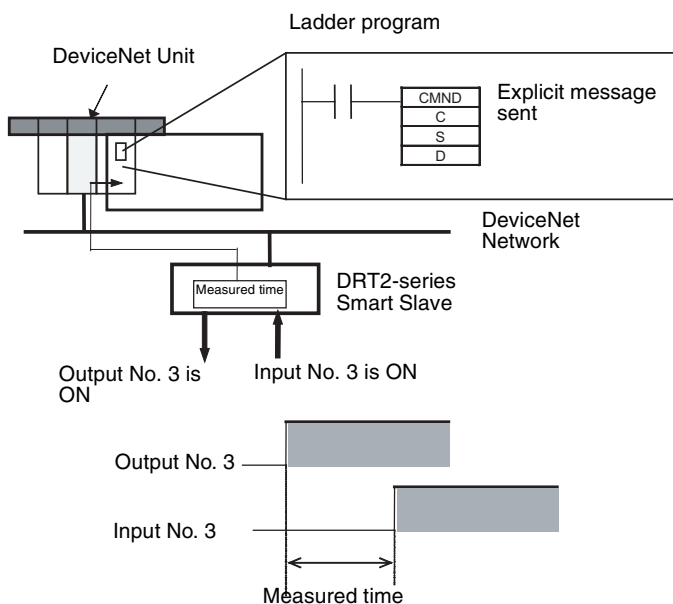

### Operation

Reads the measured operation time for contact No. 3 of the Smart Slave (the time from when output No. 3 changes to ON until input No. 3 changes to ON).

The data is read using the EXPLICIT MESSAGE SEND command (2801).

The command data is written in words starting from D01000 in the PLC and the response data is stored in words starting from D02000.

If the command does not end normally, the end code is stored in D00006 and the send command is re-executed.

### Command Details

- [CMND S D C]  
 S: D01000  
 D (first response word): D02000  
 C: D00000

Contents of S

Address	Contents (Hex)	Meaning
D01000	28 01	Command code
D01001	0B 0E	Smart Slave node address: 11 Service code: 0E Hex
D01002	00 97	Class ID: 0097 Hex
D01003	00 04	Instance ID: 0004 Hex
D01004	66 **	Attribute ID: 66 ** Hex (Set any value for the blank boxes.)

Contents of C

Address	Contents (Hex)	Meaning
D00000	00 09	Number of bytes of command data
D00001	00 09	Number of bytes of response data
D00002	00 00	Destination DeviceNet Unit network address: 0
D00003	05 FE	Destination DeviceNet Unit node address: 5 Destination DeviceNet Unit unit address: FE Hex (or 10 Hex)
D00004	00 00	Response required Communications port number: 0 Number of retries: 0
D00005	00 3C	Response monitoring time: 6 s

**Response**

Contents of D

Address	Contents (Hex)	Meaning
D02000	28 01	
D02001	00 00	
D02002	00 02	
D02003	0B 8E	Response source node address: 11 (0B Hex) Normal completion: 8E Hex
D02004	00 00	Operation time monitor result (0000: Within range)  <div style="text-align: center;"> <p>0000</p> <p>Not used.</p> <p>Result is stored.</p> </div>



# Appendix B

## Using Another Company's Master Unit

This appendix explains how to operate an OMRON Slave when the Slave is connected to a Master manufactured by another company.

**Note** If the Slave has outputs, do not communicate with the Master through a bit strobe connection. There are several DeviceNet I/O communications methods, including poll and bit strobe connections, but DeviceNet specifications allow the bit strobe connection with inputs only. OMRON Master Units conform to these specifications and communicate with Output Slaves through a poll connection, but some other company's Masters allow bit strobe connections with Output Slaves. Before connecting an OMRON Slave to another company's Master, verify the Master's connection specifications.

When connecting an OMRON Slave to another company's Master, it may be necessary to install the OMRON Slave's EDS file in the other company's configurator to set the Slave's information in the Master. With some companies' Masters, the Slaves can be connected without making settings.

With some other companies' configurators and depending on the Slave being used, installing the OMRON Slave's EDS file in the configurator will allow you to make various parameter settings from the configurator.

**Note** If you cannot obtain a copy of the EDS file or the other company's configurator does not support EDS files, settings such as the connection type and data size must be input directly.

### Installing EDS Files

EDS files are provided by the manufacturer for each Slave and contain settings such as the Slave's ID and I/O data sizes. If the EDS file is installed in the configurator, the Slave's settings can be changed and the I/O size will be input automatically when the Master's scan list is created.

EDS files for the Slaves described in this manual can be downloaded from the product catalog at the following website:

→<http://www.odva.astem.or.jp/>

Locate the EDS file for the desired Slave and install that EDS file in the configurator. Refer to the configurator's operation manual for details on the installation procedure.

### More Detailed DeviceNet Specifications for Slaves

The following device profiles contain more detailed DeviceNet specifications for Slaves if more information needs to be registered in the scan list.

## Device Profiles of General-purpose and Environment-resistive Slaves

General data	Compatible DeviceNet Specifications	Volume I - Release 2.0 Volume II - Release 2.0
	Vendor name	OMRON Corporation Vendor ID = 47
	Device profile name	Slaves: General purpose Discrete I/O Profile number = 7
	Manufacturer catalog number	W404
	Manufacturer revision	1.01
Physical conformance data	Network current consumption	See note.
	Connector type	Open plug
	Physical insulation	No
	Supported indicators	Module, Network
	MAC ID setting	Software switch or rotary switch (software switch: No. 64 to 99)
	Default MAC ID	0
	Baud rate setting	None (automatic recognition)
	Supported baud rates	125 kbps, 250 kbps, and 500 kbps
Communications data	Predefined Master/Slave connection set	Group 2 only server
	Dynamic connection support (UCMM)	No
	Explicit message fragmentation support	Yes

**Note** The network current consumption depends on the Slave being used, as shown in the following table.

Model	Network current consumption
DRT2-ID08(-1)	24 V DC, 55 mA max.
DRT2-OD08	24 V DC, 50 mA max.
DRT2-OD08-1	24 V DC, 45 mA max.
DRT2-ID16(-1)	24 V DC, 60 mA max.
DRT2-OD16(-1)	
DRT2-MD16	24 V DC, 55 mA max.
DRT2-MD16-1	24 V DC, 50 mA max.
DRT2-ROS16	24 V DC, 395 mA max.
XWT-ID16(-1)	24 V DC, 10 mA max.
XWT-OD16(-1)	
XWT-ID08-1	24 V DC, 5 mA max.
XWT-OD08(-1)	24 V DC, 4.5 mA max.
DRT2-ID16TA(-1)	24 V DC, 80 mA max.
DRT2-OD16TA(-1)	
DRT2-MD16TA(-1)	
DRT2-ID08C(-1)	24 V DC, 115 mA max.
DRT2-HD16C(-1)	24 V DC, 190 mA max.
DRT2-OD08C(-1)	24 V DC, 60 mA max.
DRT2-ID04CL(-1)	24 V DC, 50 mA max.
DRT2-ID08CL(-1)	24 V DC, 50 mA max.
DRT2-HD16CL(-1)	24 V DC, 55 mA max.
DRT2-OD04CL(-1)	24 V DC, 45 mA max.
DRT2-OD08CL(-1)	24 V DC, 50 mA max.
DRT2-WD16CL(-1)	24 V DC, 55 mA max.
DRT2-MD16CL(-1)	24 V DC, 55 mA max.
DRT2-ID16S(-1)	24 V DC, 230 mA max.
DRT2-MD16S(-1)	24 V DC, 135 mA max.
DRT2-ID16ML(X)(-1)	24 V DC, 60 mA max.
DRT2-OD16ML(X)(-1)	24 V DC, 75 mA max.
DRT2-ID32ML(-1)	24 V DC, 100 mA max.
DRT2-OD32ML(-1)	24 V DC, 120 mA max.

Model	Network current consumption
DRT2-MD32ML(-1)	24 V DC, 110 mA max.
DRT2-ID32B(-1)	24 V DC, 100 mA max.
DRT2-OD32B(-1)	24 V DC, 120 mA max.
DRT2-MD32B(-1)	24 V DC, 110 mA max.
DRT2-ID32BV(-1)	24 V DC, 100 mA max.
DRT2-OD32BV(-1)	24 V DC, 120 mA max.
DRT2-MD32BV(-1)	24 V DC, 110 mA max.
DRT2-ID16SL	24 V DC, 28 mA max.
DRT2-ID16SL-1	24 V DC, 27 mA max.
DRT2-ID32SL	24 V DC, 100 mA max.
DRT2-ID32SL-1	24 V DC, 90 mA max.
DRT2-OD16SL	24 V DC, 32 mA max.
DRT2-OD16SL-1	24 V DC, 31 mA max.
DRT2-OD32SL	24 V DC, 80 mA max.
DRT2-OD32SL-1	24 V DC, 75 mA max.
DRT2-MD32SL	24 V DC, 80 mA max.
DRT2-MD32SL-1	24 V DC, 80 mA max.
DRT2-ID16SLH	24 V DC, 33 mA max.
DRT2-ID16SLH-1	24 V DC, 32 mA max.
DRT2-ID32SLH	24 V DC, 100 mA max.
DRT2-ID32SLH-1	24 V DC, 105 mA max.
DRT2-OD16SLH	24 V DC, 35 mA max.
DRT2-OD16SLH-1	24 V DC, 35 mA max.
DRT2-OD32SLH	24 V DC, 80 mA max.
DRT2-OD32SLH-1	24 V DC, 85 mA max.
DRT2-MD32SLH	24 V DC, 90 mA max.
DRT2-MD32SLH-1	24 V DC, 90 mA max.

## Device Profiles of Analog Slaves

General data	Compatible DeviceNet Specifications	Volume I - Release 2.0 Volume II - Release 2.0
	Vendor name	OMRON Corporation      Vendor ID = 47
	Device profile name	Slaves: Generic      Profile number = 0
	Manufacturer catalog number	W404
	Manufacturer revision	1.01
Physical conformance data	Network current consumption	See note.
	Connector type	Open plug
	Physical insulation	Yes
	Supported indicators	Module, Network
	MAC ID setting	Software switch or rotary switch (software switch: No. 64 to 99)
	Default MAC ID	0
	Baud rate setting	None (automatic recognition)
Supported baud rates	125 kbps, 250 kbps, and 500 kbps	
Communications data	Predefined Master/Slave connection set	Group 2 only server
	Dynamic connection support (UCMM)	No
	Explicit message fragmentation support	Yes



**Note** The network current consumption depends on the Slave being used, as shown in the following table.

Model	Network current consumption
DRT2-AD04	90 mA
DRT2-DA02	120 mA
DRT2-AD04H	70 mA max.
DRT2-TS04T	70 mA max.
DRT2-TS04P	70 mA max.

## Object Mounting

### Identity Object (0x01)

Object class	Attribute	Not supported
	Service	Not supported

Object instance	Attribute	ID	Contents	Get (read)	Set (write)	Value
		1	Vendor	Yes	No	47
		2	Device type	Yes	No	See note.
		3	Product code	Yes	No	See note.
		4	Revision	Yes	No	1.1
		5	Status (bits supported)	Yes	No	Bit 0 only
		6	Serial number	Yes	No	Unique for each Unit
		7	Product name	Yes	No	See note.
		8	State	No	No	---
	Service	<b>DeviceNet service</b>		<b>Parameter option</b>		
		05	Reset	No		
		0E	Get_Attribute_Single	No		

**Note** The product code and product name depend on the type of Slave being used, as shown in the following table.

Model		Device type	Product code	Product name
Basic Unit	Expansion Unit			
DRT2-ID16	None	07 Hex	700	DRT2-ID16
DRT2-ID16	XWT-ID08	07 Hex	701	DRT2-ID16
DRT2-ID16	XWT-ID16	07 Hex	702	DRT2-ID16
DRT2-ID16	XWT-OD08	07 Hex	703	DRT2-ID16
DRT2-ID16	XWT-OD16	07 Hex	704	DRT2-ID16
DRT2-ID16	XWT-ID08-1	07 Hex	705	DRT2-ID16
DRT2-ID16	XWT-ID16-1	07 Hex	706	DRT2-ID16
DRT2-ID16	XWT-OD08-1	07 Hex	707	DRT2-ID16
DRT2-ID16	XWT-OD16-1	07 Hex	708	DRT2-ID16
DRT2-ID16-1	None	07 Hex	741	DRT2-ID16-1
DRT2-ID16-1	XWT-ID08	07 Hex	742	DRT2-ID16-1
DRT2-ID16-1	XWT-ID16	07 Hex	743	DRT2-ID16-1
DRT2-ID16-1	XWT-OD08	07 Hex	744	DRT2-ID16-1
DRT2-ID16-1	XWT-OD16	07 Hex	745	DRT2-ID16-1
DRT2-ID16-1	XWT-ID08-1	07 Hex	746	DRT2-ID16-1
DRT2-ID16-1	XWT-ID16-1	07 Hex	747	DRT2-ID16-1
DRT2-ID16-1	XWT-OD08-1	07 Hex	748	DRT2-ID16-1
DRT2-ID16-1	XWT-OD16-1	07 Hex	749	DRT2-ID16-1

Model		Device type	Product code	Product name
Basic Unit	Expansion Unit			
DRT2-OD16	None	07 Hex	782	DRT2-OD16
DRT2-OD16	XWT-ID08	07 Hex	783	DRT2-OD16
DRT2-OD16	XWT-ID16	07 Hex	784	DRT2-OD16
DRT2-OD16	XWT-OD08	07 Hex	785	DRT2-OD16
DRT2-OD16	XWT-OD16	07 Hex	786	DRT2-OD16
DRT2-OD16	XWT-ID08-1	07 Hex	787	DRT2-OD16
DRT2-OD16	XWT-ID16-1	07 Hex	788	DRT2-OD16
DRT2-OD16	XWT-OD08-1	07 Hex	789	DRT2-OD16
DRT2-OD16	XWT-OD16-1	07 Hex	790	DRT2-OD16
DRT2-OD16-1	None	07 Hex	823	DRT2-OD16-1
DRT2-OD16-1	XWT-ID08	07 Hex	824	DRT2-OD16-1
DRT2-OD16-1	XWT-ID16	07 Hex	825	DRT2-OD16-1
DRT2-OD16-1	XWT-OD08	07 Hex	826	DRT2-OD16-1
DRT2-OD16-1	XWT-OD16	07 Hex	827	DRT2-OD16-1
DRT2-OD16-1	XWT-ID08-1	07 Hex	828	DRT2-OD16-1
DRT2-OD16-1	XWT-ID16-1	07 Hex	829	DRT2-OD16-1
DRT2-OD16-1	XWT-OD08-1	07 Hex	830	DRT2-OD16-1
DRT2-OD16-1	XWT-OD16-1	07 Hex	831	DRT2-OD16-1
DRT2-ROS16	None	07 Hex	950	DRT2-ROS16
DRT2-ROS16	XWT-ID08	07 Hex	951	DRT2-ROS16
DRT2-ROS16	XWT-ID16	07 Hex	952	DRT2-ROS16
DRT2-ROS16	XWT-OD08	07 Hex	953	DRT2-ROS16
DRT2-ROS16	XWT-OD16	07 Hex	954	DRT2-ROS16
DRT2-ROS16	XWT-ID08-1	07 Hex	955	DRT2-ROS16
DRT2-ROS16	XWT-ID16-1	07 Hex	956	DRT2-ROS16
DRT2-ROS16	XWT-OD08-1	07 Hex	957	DRT2-ROS16
DRT2-ROS16	XWT-OD16-1	07 Hex	958	DRT2-ROS16
DRT2-ID08		07 Hex	878	DRT2-ID08
DRT2-ID08-1		07 Hex	879	DRT2-ID08-1
DRT2-OD08		07 Hex	880	DRT2-OD08
DRT2-OD08-1		07 Hex	881	DRT2-OD08-1
DRT2-MD16		07 Hex	876	DRT2-MD16
DRT2-MD16-1		07 Hex	877	DRT2-MD16-1
DRT2-ID16TA		07 Hex	1300	DRT2-ID16TA
DRT2-ID16TA-1		07 Hex	1301	DRT2-ID16TA-1
DRT2-OD16TA		07 Hex	1302	DRT2-OD16TA
DRT2-OD16TA-1		07 Hex	1303	DRT2-OD16TA-1
DRT2-MD16TA		07 Hex	1304	DRT2-MD16TA
DRT2-MD16TA-1		07 Hex	1305	DRT2-MD16TA-1
DRT2-ID16S		07 Hex	870	DRT2-ID16S
DRT2-ID16S-1		07 Hex	871	DRT2-ID16S-1
DRT2-MD16S		07 Hex	872	DRT2-MD16S
DRT2-MD16S-1		07 Hex	873	DRT2-MD16S-1
DRT2-ID16ML(X)		07 Hex	1397	DRT2-ID16ML(X)
DRT2-ID16ML(X)-1		07 Hex	1398	DRT2-ID16ML(X)-1
DRT2-ID32ML		07 Hex	1306	DRT2-ID32ML
DRT2-ID32ML-1		07 Hex	1307	DRT2-ID32ML-1
DRT2-OD16ML(X)		07 Hex	1399	DRT2-OD16ML(X)

Model		Device type	Product code	Product name
Basic Unit	Expansion Unit			
DRT2-OD16ML(X)-1		07 Hex	1400	DRT2-OD16ML(X)-1
DRT2-OD32ML		07 Hex	1308	DRT2-OD32ML
DRT2-OD32ML-1		07 Hex	1309	DRT2-OD32ML-1
DRT2-MD32ML		07 Hex	1310	DRT2-MD32ML
DRT2-MD32ML-1		07 Hex	1311	DRT2-MD32ML-1
DRT2-ID32B		07 Hex	1315	DRT2-ID32B
DRT2-ID32B-1		07 Hex	1318	DRT2-ID32B-1
DRT2-OD32B		07 Hex	1316	DRT2-OD32B
DRT2-OD32B-1		07 Hex	1319	DRT2-OD32B-1
DRT2-MD32B		07 Hex	1317	DRT2-MD32B
DRT2-MD32B-1		07 Hex	1320	DRT2-MD32B-1
DRT2-ID32BV		07 Hex	1321	DRT2-ID32BV
DRT2-ID32BV-1		07 Hex	1324	DRT2-ID32BV-1
DRT2-OD32BV		07 Hex	1322	DRT2-OD32BV
DRT2-OD32BV-1		07 Hex	1325	DRT2-OD32BV-1
DRT2-MD32BV		07 Hex	1323	DRT2-MD32BV
DRT2-MD32BV-1		07 Hex	1326	DRT2-MD32BV-1
DRT2-ID16SL		07 Hex	1003	DRT2-ID16SL
DRT2-ID16SL-1		07 Hex	1004	DRT2-ID16SL-1
DRT2-OD16SL		07 Hex	1007	DRT2-OD16SL
DRT2-OD16SL-1		07 Hex	1008	DRT2-OD16SL-1
DRT2-ID32SL		07 Hex	1009	DRT2-ID32SL
DRT2-ID32SL-1		07 Hex	1010	DRT2-ID32SL-1
DRT2-OD32SL		07 Hex	1013	DRT2-OD32SL
DRT2-OD32SL-1		07 Hex	1014	DRT2-OD32SL-1
DRT2-MD32SL		07 Hex	1011	DRT2-MD32SL
DRT2-MD32SL-1		07 Hex	1012	DRT2-MD32SL-1
DRT2-ID16SLH		07 Hex	991	DRT2-ID16SLH
DRT2-ID16SLH-1		07 Hex	992	DRT2-ID16SLH-1
DRT2-OD16SLH		07 Hex	995	DRT2-OD16SLH
DRT2-OD16SLH-1		07 Hex	996	DRT2-OD16SLH-1
DRT2-ID32SLH		07 Hex	997	DRT2-ID32SLH
DRT2-ID32SLH-1		07 Hex	998	DRT2-ID32SLH-1
DRT2-OD32SLH		07 Hex	1001	DRT2-OD32SLH
DRT2-OD32SLH-1		07 Hex	1002	DRT2-OD32SLH-1
DRT2-MD32SLH		07 Hex	999	DRT2-MD32SLH
DRT2-MD32SLH-1		07 Hex	1000	DRT2-MD32SLH-1
DRT2-HD16C		07 Hex	864	DRT2-HD16C
DRT2-HD16C-1		07 Hex	865	DRT2-HD16C-1
DRT2-ID08C		07 Hex	866	DRT2-ID08C
DRT2-ID08C-1		07 Hex	867	DRT2-ID08C-1
DRT2-OD08C		07 Hex	868	DRT2-OD08C
DRT2-OD08C-1		07 Hex	869	DRT2-OD08C-1
DRT2-ID04CL		07 Hex	886	DRT2-ID04CL
DRT2-ID04CL-1		07 Hex	887	DRT2-ID04CL-1
DRT2-ID08CL		07 Hex	1376	DRT2-ID08CL
DRT2-ID08CL-1		07 Hex	1377	DRT2-ID08CL-1
DRT2-HD16CL		07 Hex	1378	DRT2-HD16CL

Model		Device type	Product code	Product name
Basic Unit	Expansion Unit			
DRT2-HD16CL-1		07 Hex	1379	DRT2-HD16CL-1
DRT2-OD04CL		07 Hex	888	DRT2-OD04CL
DRT2-OD04CL-1		07 Hex	889	DRT2-OD04CL-1
DRT2-OD08CL		07 Hex	1380	DRT2-OD08CL
DRT2-OD08CL-1		07 Hex	1381	DRT2-OD08CL-1
DRT2-WD16CL		07 Hex	1382	DRT2-WD16CL
DRT2-WD16CL-1		07 Hex	1383	DRT2-WD16CL-1
DRT2-MD16CL		07 Hex	1384	DRT2-MD16CL
DRT2-MD16CL-1		07 Hex	1385	DRT2-MD16CL-1
DRT2-AD04		00 Hex	313	DRT2-AD04
DRT2-DA02		00 Hex	314	DRT2-DA02
DRT2-TS04T		00 Hex	335	DRT2-TS04T
DRT2-TS04P		00 Hex	336	DRT2-TS04P
DRT2-AD04H		00 Hex	337	DRT2-AD04H

### Message Router Object (0x02)

Object class	Attribute	Not supported
	Service	Not supported
Object instance	Attribute	Not supported
	Service	Not supported
Vendor specification addition		None

### DeviceNet Object (0x03)

Object class	Attribute	Not supported
	Service	Not supported

Object instance	Attribute	ID	Contents	Get (read)	Set (write)	Value
		1	MAC ID	Yes	Yes	---
2	Baud rate	Yes	No	---		
3	BOI	Yes	No	00 (hexadecimal)		
4	Bus Off counter	Yes	No	---		
5	Allocation information	Yes	No	---		
6	MAC ID switch changed	No	No	---		
7	Baud rate switch changed	No	No	---		
8	MAC ID switch value	No	No	---		
9	Baud rate switch value	No	No	---		
Service	DeviceNet service			Parameter option		
	0E	Get_Attribute_Single	None			
	4B	Allocate_Master/Slave_Connection_Set	None			
	4C	Release_Master/Slave_Connection_Set	None			

**Note** SET condition for MAC ID: MAC ID No. 64 to 99.

**Assembly Object (0x04)**

<b>Object class</b>	<b>Attribute</b>	Not supported
	<b>Service</b>	Not supported

<b>Object instance</b>	<b>Attribute</b>	<b>ID</b>	<b>Contents</b>	<b>Get (read)</b>	<b>Set (write)</b>	<b>Value</b>
		1	Number of members in list	No	No	---
		2	Member list	No	No	---
		3	Data	Yes	No	---
	<b>Service</b>	<b>DeviceNet service</b>		<b>Parameter option</b>		
	0E	Get_Attribute_Single	None			

The assembly instances for DRT2 Slaves are given below.

**General-purpose Slaves (Input)**

Instance number	Type	Bit allocation								Supported model
		7	6	5	4	3	2	1	0	
Assembly instance 3 4 inputs	Input	7	6	5	4	3	2	1	0	DRT2-ID04CL(-1)
Assembly instance 4 8 inputs	Input	7	6	5	4	3	2	1	0	DRT2-ID08(-1) DRT2-MD16(-1) DRT2-OD16(-1) + XWT-ID08(-1) DRT2-ID08C(-1) DRT2-ID08CL(-1) DRT2-MD16CL(-1) DRT2-ROS16 + XWT-ID08(-1) DRT2-MD16TA(-1) DRT2-MD16S(-1)
Assembly instance 5 16 inputs	Input	7	6	5	4	3	2	1	0	DRT2-ID16(-1)
		15	14	13	12	11	10	9	8	DRT2-ID16(-1) + XWT-OD08(-1) DRT2-ID16(-1) + XWT-OD16(-1) DRT2-OD16(-1) + XWT-ID16(-1) DRT2-HD16C(-1) DRT2-HD16CL(-1) DRT2-ID16S(-1) DRT2-ROS16 + XWT-ID16(-1) DRT2-ID16TA(-1) DRT2-ID16ML(X)(-1) DRT2-ID16SL(-1) DRT2-ID16SLH(-1) DRT2-MD32ML(-1) DRT2-MD32B(-1) DRT2-MD32BV(-1) DRT2-MD32SL(-1) DRT2-MD32SLH(-1)
Assembly instance 6 32 inputs	Input	7	6	5	4	3	2	1	0	DRT2-ID16(-1) + XWT-ID16(-1)
		15	14	13	12	11	10	9	8	DRT2-ID32ML(-1)
		23	22	21	20	19	18	17	16	DRT2-ID32B(-1)
		31	30	29	28	27	26	25	24	DRT2-ID32BV(-1) DRT2-ID32SL(-1) DRT2-ID32SLH(-1)
Assembly instance 7 24 inputs	Input	7	6	5	4	3	2	1	0	DRT2-ID16(-1) + XWT-ID08(-1)
		15	14	13	12	11	10	9	8	
		23	22	21	20	19	18	17	16	
Assembly instance 100 Status flags	Input	7	6	5	4	3	2	1	0	All models
Assembly instance 101 8 inputs + status flags	Input	7	6	5	4	3	2	1	0	DRT2-ID04CL(-1)
		7	6	5	4	3	2	1	0	DRT2-ID08(-1) DRT2-MD16(-1) DRT2-OD16(-1) + XWT-ID08(-1) DRT2-ID08C(-1) DRT2-ID08CL(-1) DRT2-MD16CL(-1) DRT2-ROS16 + XWT-ID08(-1) DRT2-MD16TA(-1)

Instance number	Type	Bit allocation								Supported model
Assembly instance 102 16 inputs + status flags	Input	7	6	5	4	3	2	1	0	DRT2-ID16(-1)
		15	14	13	12	11	10	9	8	DRT2-ID16(-1) + XWT-OD08(-1)
		7	6	5	4	3	2	1	0	DRT2-ID16(-1) + XWT-OD16(-1)
										DRT2-OD16(-1) + XWT-ID16(-1)
Assembly instance 103 24 inputs + status flags	Input	7	6	5	4	3	2	1	0	DRT2-ID16(-1) + XWT-ID08(-1)
		15	14	13	12	11	10	9	8	
		23	22	21	20	19	18	17	16	
		7	6	5	4	3	2	1	0	
Assembly instance 104 32 inputs + status flags	Input	7	6	5	4	3	2	1	0	DRT2-ID16(-1) + XWT-ID16(-1)
		15	14	13	12	11	10	9	8	DRT2-ID32ML(-1)
		23	22	21	20	19	18	17	16	DRT2-ID32B(-1)
		31	30	29	28	27	26	25	24	DRT2-ID32BV(-1)
		7	6	5	4	3	2	1	0	DRT2-ID32SL(-1)
								DRT2-ID32SLH(-1)		

**Note** The shaded parts indicate status bits.

### General-purpose Slaves (Output)

Instance number	Type	Bit allocation								Supported model
Assembly instance 33	Output	7	6	5	4	3	2	1	0	DRT2-OD04CL(-1)
Assembly instance 34 8 outputs	Output	7	6	5	4	3	2	1	0	DRT2-OD08(-1)
										DRT2-MD16(-1)
										DRT2-ID16(-1) + XWT-OD08(-1)
										DRT2-OD08C(-1)
										DRT2-OD08CL(-1)
										DRT2-MD16CL(-1)
										DRT2-MD16TA(-1)
								DRT2-MD16S(-1)		

Instance number	Type	Bit allocation								Supported model
Assembly instance 35 16 outputs	Output	7	6	5	4	3	2	1	0	DRT2-OD16(-1) DRT2-ID16(-1) + XWT-OD16(-1) DRT2-OD16(-1) + XWT-ID08(-1) DRT2-OD16(-1) + XWT-ID16(-1) DRT2-ROS16 DRT2-WD16CL(-1) DRT2-OD16TA(-1) DRT2-OD16ML(X)(-1) DRT2-OD16SL(-1) DRT2-OD16SLH(-1) DRT2-MD32ML(-1) DRT2-MD32B(-1) DRT2-MD32BV(-1) DRT2-MD32SL(-1) DRT2-MD32SLH(-1)
		15	14	13	12	11	10	9	8	
Assembly instance 36 32 outputs	Output	7	6	5	4	3	2	1	0	DRT2-OD16(-1) + XWT-OD16(-1) DRT2-ROS16 + XWT-OD16(-1) DRT2-OD32ML(-1) DRT2-OD32B(-1) DRT2-OD32BV(-1) DRT2-OD32SL(-1) DRT2-OD32SLH(-1)
		15	14	13	12	11	10	9	8	
		23	22	21	20	19	18	17	16	
		31	30	29	28	27	26	25	24	
Assembly instance 37 24 outputs	Output	7	6	5	4	3	2	1	0	DRT2-OD16(-1) + XWT-OD08(-1) DRT2-ROS16 + XWT-OD08(-1)
		15	14	13	12	11	10	9	8	
		23	22	21	20	19	18	17	16	

**Analog Slaves (Input)**

Instance number	Byte	Bit allocation								Supported model
Instance 104 Analog Data 1 (input)	+0	Input 0, Analog Data 1								DRT2-AD04 DRT2-AD04H
	+1									
	+2	Input 1, Analog Data 1								
	+3									
	+4	Input 2, Analog Data 1								
	+5									
	+6	Input 3, Analog Data 1								
	+7									
Instance 114 Analog Data 2 (input)	+0	Input 0, Analog Data 2								DRT2-AD04 DRT2-AD04H
	+1									
	+2	Input 1, Analog Data 2								
	+3									
	+4	Input 2, Analog Data 2								
	+5									
	+6	Input 3, Analog Data 2								
	+7									
Instance 121 Generic Status Flags	+0	0	0	MRF	CCW	RHW	NPW	0	0	DRT2-AD04 DRT2-DA02 DRT2-AD04H



Instance number	Byte	Bit allocation								Supported model
Instance 122 Top/Valley Detection Timing Flags	+0	0	0	0	0	V_ST3	V_ST2	V_ST1	V_ST0	DRT2-AD04
	+1	0	0	0	0	T_ST3	T_ST2	T_ST1	T_ST0	DRT2-AD04H
Instance 134 Analog Status Flags	+0	BW0	T_ST0	V_ST0	HH0	H0	PS0	L0	LL0	DRT2-AD04
	+1	BW1	T_ST1	V_ST1	HH1	H1	PS1	L1	LL1	DRT2-AD04H
	+2	BW2	T_ST2	V_ST2	HH2	H2	PS2	L2	LL2	
	+3	BW3	T_ST3	V_ST3	HH3	H3	PS3	L3	LL3	
Instance 144 Analog Data 1 + Ana- log Data 2	+0	Input 0, Analog Data 1								DRT2-AD04 DRT2-AD04H
	+1									
	+2	Input 1, Analog Data 1								
	+3									
	+4	Input 2, Analog Data 1								
	+5									
	+6	Input 3, Analog Data 1								
	+7									
	+8	Input 0, Analog Data 2								
	+9									
	+10	Input 1, Analog Data 2								
	+11									
	+12	Input 2, Analog Data 2								
	+13									
+14	Input 3, Analog Data 2									
+15										
Instance 151 Top/Valley Detection Timing Flags + Generic Status Flags	+0	0	0	0	0	V_ST3	V_ST2	V_ST1	V_ST0	DRT2-AD04
	+1	0	0	0	0	T_ST3	T_ST2	T_ST1	T_ST0	
	+2	0	0	MRF	CCW	RHW	NPW	0	0	
Instance 164 Analog Status Flags + Generic Status Flags	+0	BW0	T_ST0	V_ST0	HH0	H0	PS0	L0	LL0	DRT2-AD04
	+1	BW1	T_ST1	V_ST1	HH1	H1	PS1	L1	LL1	DRT2-AD04H
	+2	BW2	T_ST2	V_ST2	HH2	H2	PS2	L2	LL2	
	+3	BW3	T_ST3	V_ST3	HH3	H3	PS3	L3	LL3	
	+4	0	0	MRF	CCW	RHW	NPW	0	0	
Instance 174 Analog Data 1 + Top/ Valley Detection Tim- ing Flags	+0	Input 0, Analog Data 1								DRT2-AD04 DRT2-AD04H
	+1									
	+2	Input 1, Analog Data 1								
	+3									
	+4	Input 2, Analog Data 1								
	+5									
	+6	Input 3, Analog Data 1								
	+7									
	+8	0	0	0	0	V_ST3	V_ST2	V_ST1	V_ST0	
+9	0	0	0	0	T_ST3	T_ST2	T_ST1	T_ST0		

Instance number	Byte	Bit allocation								Supported model
Instance 184 Analog Data 1 + Top/ Valley Detection Tim- ing Flags + Generic Status Flags	+0	Input 0, Analog Data 1								DRT2-AD04 DRT2-AD04H
	+1									
	+2	Input 1, Analog Data 1								
	+3									
	+4	Input 2, Analog Data 1								
	+5									
	+6	Input 3, Analog Data 1								
	+7									
	+8	0	0	0	0	V_ST3	V_ST2	V_ST1	V_ST0	
	+9	0	0	0	0	T_ST3	T_ST2	T_ST1	T_ST0	
	+10	0	0	MRF	CCW	RHW	NPW	0	0	

### Analog Slaves (Output)

Instance number	Byte	Bit allocation								Supported model
Instance 190 Hold Flags	+0					HD3	HD1	HD1	HD0	DRT2-AD04 DRT2-AD04H
Instance 192 Analog output data	+0	Input 0, Analog Data								DRT2-DA02
	+1									
	+2	Input 1, Analog Data								
	+3									

### Temperature Input Terminals (Inputs)

Instance number	Byte	Bit allocation								Supported model
Instance 104 Temperature data 1, normal display	+0	Ch0 Temperature Data 1								DRT2-TS04T DRT2-TS04P
	+1									
	+2	Ch1 Temperature Data 1								
	+3									
	+4	Ch2 Temperature Data 1								
	+5									
	+6	Ch3 Temperature Data 1								
+7										
Instance 108 Instance 104 Temperature data 1, 1/100 display	+0	Ch0 Temperature Data 1								DRT2-TS04T DRT2-TS04P
	+1									
	+2	Ch1 Temperature Data 1								
	+3									
	+4	Ch2 Temperature Data 1								
	+5									
	+6	Ch3 Temperature Data 1								
	+7									
	+8	Ch2 Temperature Data 1								
	+9									
	+10	Ch3 Temperature Data 1								
	+11									
	+12	Ch3 Temperature Data 1								
	+13									
	+14	Ch3 Temperature Data 1								
+15										

Instance number	Byte	Bit allocation								Supported model
Instance 114 Instance 104 Temperature data 2, normal display	+0	Ch0 Temperature Data 2								DRT2-TS04T DRT2-TS04P
	+1									
	+2	Ch1 Temperature Data 2								
	+3									
	+4	Ch2 Temperature Data 2								
	+5									
	+6	Ch3 Temperature Data 2								
Instance 118 Instance 104 Temperature data 2, 1/100 display	+0	Ch0 Temperature Data 2								DRT2-TS04T DRT2-TS04P
	+1									
	+2									
	+3									
	+4	Ch1 Temperature Data 2								
	+5									
	+6									
	+7									
	+8	Ch2 Temperature Data 2								
	+9									
	+10									
	+11									
	+12	Ch3 Temperature Data 2								
	+13									
+14										
+15										
Instance 121 Generic status flags	+0	CCB	0	MRF	CCW	RHW	NPW	0	0	DRT2-TS04T DRT2-TS04P
Instance 122 Top/valley detec- tion timing flags	+0	0	0	0	0	V_ST3	V_ST2	V_ST1	V_ST0	DRT2-TS04T
	+1	0	0	0	0	T_ST3	T_ST2	T_ST1	T_ST0	DRT2-TS04P
Instance 134 Analog status flags	+0	BW0	T_ST0	V_ST0	HH0	H0	PS0	L0	LL0	DRT2-AD04
	+1	BW1	T_ST1	V_ST1	HH1	H1	PS1	L1	LL1	DRT2-AD04H
	+2	BW2	T_ST2	V_ST2	HH2	H2	PS2	L2	LL2	
	+3	BW3	T_ST3	V_ST3	HH3	H3	PS3	L3	LL3	

Instance number	Byte	Bit allocation	Supported model
Instance 144 Temperature data 1 + Temperature data 2, normal display	+0	Ch0 Temperature Data 1	DRT2-TS04T DRT2-TS04P
	+1		
	+2	Ch1 Temperature Data 1	
	+3		
	+4	Ch2 Temperature Data 1	
	+5		
	+6	Ch3 Temperature Data 1	
	+7		
	+8	Ch0 Temperature Data 2	
	+9		
	+10	Ch1 Temperature Data 2	
	+11		
	+12	Ch2 Temperature Data 2	
	+13		
+14	Ch3 Temperature Data 2		
+15			
Instance 148 Temperature data 1 + Temperature data 2, 1/100 display	+0	Ch0 Temperature Data 1	DRT2-TS04T DRT2-TS04P
	+1		
	+2	Ch1 Temperature Data 1	
	+3		
	+4	Ch1 Temperature Data 1	
	+5		
	+6	Ch2 Temperature Data 1	
	+7		
	+8	Ch2 Temperature Data 1	
	+9		
	+10	Ch3 Temperature Data 1	
	+11		
	+12	Ch3 Temperature Data 1	
	+13		
	+14	Ch0 Temperature Data 2	
	+15		
	+16	Ch0 Temperature Data 2	
	+17		
	+18	Ch1 Temperature Data 2	
	+19		
	+20	Ch1 Temperature Data 2	
	+21		
	+22	Ch2 Temperature Data 2	
	+23		
+24	Ch2 Temperature Data 2		
+25			
+26	Ch3 Temperature Data 2		
+27			
+28	Ch3 Temperature Data 2		
+29			
+30	Ch3 Temperature Data 2		
+31			

Instance number	Byte	Bit allocation								Supported model
Instance 151 Top/valley detection timing flag + generic status flags	+0	0	0	0	0	V_ST3	V_ST2	V_ST1	V_ST0	DRT2-TS04T DRT2-TS04P
	+1	0	0	0	0	T_ST3	T_ST2	T_ST1	T_ST0	
	+2	CCB	0	MRF	CCW	RHW	NPW	0	0	
Instance 164 Analog status flags + generic status flags	+0	BW0	T_ST0	V_ST0	HH0	H0	PS0	L0	LL0	DRT2-AD04 DRT2-AD04H
	+1	BW1	T_ST1	V_ST1	HH1	H1	PS1	L1	LL1	
	+2	BW2	T_ST2	V_ST2	HH2	H2	PS2	L2	LL2	
	+3	BW3	T_ST3	V_ST3	HH3	H3	PS3	L3	LL3	
	+4	CCB	---	MRF	CCW	RHW	NPW	0	0	
Instance 174 Temperature data 1, normal display + Top/valley detection timing flag	+0	Ch0 Temperature Data 1								DRT2-TS04T DRT2-TS04P
	+1									
	+2	Ch1 Temperature Data 1								
	+3									
	+4	Ch2 Temperature Data 1								
	+5									
	+6	Ch3 Temperature Data 1								
	+7									
	+8	0	0	0	0	V_ST3	V_ST2	V_ST1	V_ST0	
	+9	0	0	0	0	T_ST3	T_ST2	T_ST1	T_ST0	
Instance 178 Temperature data 1, 1/100 display + Top/valley detection timing flag	+0	Ch0 Temperature Data 1								DRT2-TS04T DRT2-TS04P
	+1									
	+2									
	+3									
	+4	Ch1 Temperature Data 1								
	+5									
	+6									
	+7									
	+8	Ch2 Temperature Data 1								
	+9									
	+10									
	+11									
	+12	Ch3 Temperature Data 1								
	+13									
	+14									
	+15									
	+16	0	0	0	0	V_ST3	V_ST2	V_ST1	V_ST0	
	+17	0	0	0	0	T_ST3	T_ST2	T_ST1	T_ST0	
Instance 184 Temperature data 1, normal display + Top/valley detection timing flag + Generic status flags	+0	Ch0 Temperature Data 1								DRT2-TS04T DRT2-TS04P
	+1									
	+2	Ch1 Temperature Data 1								
	+3									
	+4	Ch2 Temperature Data 1								
	+5									
	+6	Ch3 Temperature Data 1								
	+7									
	+8	0	0	0	0	V_ST3	V_ST2	V_ST1	V_ST0	
	+9	0	0	0	0	T_ST3	T_ST2	T_ST1	T_ST0	
+10	CCB	0	MRF	CCW	RHW	NPW	0	0		

Instance number	Byte	Bit allocation								Supported model
Instance 188 Temperature data 1, 1/100 display + Top/valley detection timing flag + Generic status flags	+0	Ch0 Temperature Data 1								DRT2-TS04T DRT2-TS04P
	+1									
	+2									
	+3									
	+4	Ch1 Temperature Data 1								
	+5									
	+6									
	+7									
	+8	Ch2 Temperature Data 1								
	+9									
	+10									
	+11									
	+12	Ch3 Temperature Data 1								
	+13									
	+14									
	+15									
+16	0	0	0	0	V_ST3	V_ST2	V_ST1	V_ST0		
+17	0	0	0	0	T_ST3	T_ST2	T_ST1	T_ST0		
+18	CCB	0	MRF	CCW	RHW	NPW	0	0		

**Temperature Input Terminals (Output)**

Instance number	Byte	Bit allocation								Supported model
Instance 190 Hold flag	+0	---	---	---	---	HD3	HD1	HD1	HD0	DRT2-TS04T DRT2-TS04P

**Connection Object (0x05)**

Object class	Attribute	Not supported
	Service	Not supported
	Maximum number of active connections	1

Object instance 1	<b>Section</b>	<b>Information</b>		<b>Maximum number of instances</b>		
	<b>Instance type</b>	Explicit Message		1		
	<b>Production trigger</b>	Cyclic				
	<b>Transport type</b>	Server				
	<b>Transport class</b>	3				
	<b>Attribute</b>	<b>ID</b>	<b>Contents</b>	<b>Get (read)</b>	<b>Set (write)</b>	<b>Value</b>
		1	State	Yes	No	---
		2	Instance type	Yes	No	00 (hexadecimal)
		3	Transport class trigger	Yes	No	83 (hexadecimal)
		4	Produced connection ID	Yes	No	---
		5	Consumed connection ID	Yes	No	---
		6	Initial comm. characteristics	Yes	No	21 (hexadecimal)
		7	Produced connection size	Yes	No	0026 (hexadecimal)
		8	Consumed connection size	Yes	No	0026 (hexadecimal)
		9	Expected packet rate	Yes	Yes	---
		12	Watchdog timeout action	Yes	No	01 (hexadecimal)
		13	Produced connection path length	Yes	No	0000 (hexadecimal)
		14	Produced connection path	Yes	No	---
		15	Consumed connection path length	Yes	No	0000 (hexadecimal)
		16	Consumed connection path	Yes	No	---
	17	Production inhibit time	Yes	No	0000 (hexadecimal)	
<b>Service</b>	<b>DeviceNet service</b>		<b>Parameter option</b>			
	05	Reset	None			
	0E	Get_Attribute_Single	None			
	10	Set_Attribute_Single	None			

Object instance 2	<b>Section</b>	<b>Information</b>		<b>Maximum number of instances</b>		
	<b>Instance type</b>	Explicit Message		1		
	<b>Production trigger</b>	Cyclic				
	<b>Transport type</b>	Server				
	<b>Transport class</b>	2				
	<b>Attribute</b>	<b>ID</b>	<b>Contents</b>	<b>Get (read)</b>	<b>Set (write)</b>	<b>Value</b>
		1	State	Yes	No	---
		2	Instance type	Yes	No	01 (hexadecimal)
		3	Transport class trigger	Yes	No	82 (hexadecimal)
		4	Produced connection ID	Yes	No	---
		5	Consumed connection ID	Yes	No	---
		6	Initial comm. characteristics	Yes	No	01 (hexadecimal)
		7	Produced connection size	Yes	No	See note.
		8	Consumed connection size	Yes	No	See note.
		9	Expected packet rate	Yes	Yes	---
		12	Watchdog timeout action	Yes	No	00 (hexadecimal)
		13	Produced connection path length	Yes	No	See note.
		14	Produced connection path	Yes	No	See note.
		15	Consumed connection path length	Yes	No	See note.
		16	Consumed connection path	Yes	No	See note.
	17	Production inhibit time	Yes	No	0000 (hexadecimal)	
<b>Service</b>	<b>DeviceNet service</b>		<b>Parameter option</b>			
	05	Reset	None			
	0E	Get_Attribute_Single	None			
	10	Set_Attribute_Single	None			

**Note** The produced connection size and consumed connection size depend on the type of Slave being used, as shown in the following table.



Model		Name	Produced connection size	Produced connection path length	Produced connection path	Consumed connection size	Consumed connection path length	Consumed connection path
Basic Unit	Expansion Unit							
DRT2-ID08(-1)		Input Data	0002 (hexadecimal)	0006	20_04_24_04_30_03	---	0000	---
		Generic Status	0001 (hexadecimal)	0006	20_04_24_64_30_03	---	0000	---
		Input Data + Generic Status	0003 (hexadecimal)	0006	20_04_24_65_30_03	---	0000	---
DRT2-ID16(-1)	None	Input Data	0002 (hexadecimal)	0006	20_04_24_05_30_03	---	0000	---
		Generic Status	0001 (hexadecimal)	0006	20_04_24_64_30_03	---	0000	---
		Input Data + Generic Status	0003 (hexadecimal)	0006	20_04_24_66_30_03	---	0000	---
DRT2-ID16(-1)	XWT-ID08(-1)	Input Data	0003 (hexadecimal)	0006	20_04_24_07_30_03	---	0000	---
		Generic Status	0001 (hexadecimal)	0006	20_04_24_64_30_03	---	0000	---
		Input Data + Generic Status	0004 (hexadecimal)	0006	20_04_24_67_30_03	---	0000	---
DRT2-ID16(-1)	XWT-ID16(-1)	Input Data	0004 (hexadecimal)	0006	20_04_24_06_30_03	---	0000	---
		Generic Status	0001 (hexadecimal)	0006	20_04_24_64_30_03	---	0000	---
		Input Data + Generic Status	0005 (hexadecimal)	0006	20_04_24_68_30_03	---	0000	---
DRT2-ID16(-1)	XWT-OD08(-1)	Input Data	02 (hexadecimal)	0006	20_04_24_05_30_03	---	0000	---
		Generic Status	01 (hexadecimal)	0006	20_04_24_64_30_03	---	0000	---
		Input Data + Generic Status	03 (hexadecimal)	0006	20_04_24_66_30_03	---	0000	---
		Output Data	---	0000	---	0001 (hexadecimal)	0006	20_04_24_22_30_03
DRT2-ID16(-1)	XWT-OD16(-1)	Input Data	02 (hexadecimal)	0006	20_04_24_05_30_03	---	0000	---
		Generic Status	01 (hexadecimal)	0006	20_04_24_64_30_03	---	0000	---
		Input Data + Generic Status	03 (hexadecimal)	0006	20_04_24_66_30_03	---	0000	---
		Output Data	---	0000	---	0002 (hexadecimal)	0006	20_04_24_23_30_03
DRT2-OD08(-1)		Output Data	---	0000	---	0002	0006	20_04_24_22_30_03
		Generic Status	0001 (hexadecimal)	0006	20_04_24_64_30_03	---	---	---
DRT2-OD16(-1)	None	Output Data	---	0000	---	0002 (hexadecimal)	0006	20_04_24_23_30_03
		Generic Status	01 (hexadecimal)	0006	20_04_24_64_30_03	---	0000	---

Model		Name	Produced connection size	Produced connection path length	Produced connection path	Consumed connection size	Consumed connection path length	Consumed connection path
Basic Unit	Expansion Unit							
DRT2-OD16(-1)	XWT-ID08(-1)	Output Data	---	0000	---	0002 (hexadecimal)	0006	20_04_24_23_30_03
		Input Data	01 (hexadecimal)	0006	20_04_24_04_30_03	---	0000	---
		Generic Status	01 (hexadecimal)	0006	20_04_24_64_30_03	---	0000	---
		Input Data + Generic Status	02 (hexadecimal)	0006	20_04_24_65_30_03	---	0000	---
DRT2-OD16(-1)	XWT-ID16(-1)	Output Data	---	0000	---	0002 (hexadecimal)	0006	20_04_24_23_30_03
		Input Data	0002 (hexadecimal)	0006	20_04_24_05_30_03	---	0000	---
		Generic Status	0001 (hexadecimal)	0006	20_04_24_64_30_03	---	0000	---
		Input Data + Generic Status	0003 (hexadecimal)	0006	20_04_24_66_30_03	---	0000	---
DRT2-OD16(-1)	XWT-OD08(-1)	Output Data	---	0000	---	0003 (hexadecimal)	0006	20_04_24_25_30_03
		Generic Status	0001 (hexadecimal)	0006	20_04_24_64_30_03	---	0000	---
DRT2-OD16(-1)	XWT-OD16(-1)	Output Data	---	0000	---	0004 (hexadecimal)	0006	20_04_24_24_30_03
		Generic Status	0001 (hexadecimal)	0006	20_04_24_64_30_03	---	0000	---
DRT2-MD16(-1)		Input Data	0002 (hexadecimal)	0006	20_04_24_04_30_03	---	0006	---
		Generic Status	0001 (hexadecimal)	0006	20_04_24_64_30_03	---	0000	---
		Input Data + Generic Status	0003 (hexadecimal)	0006	20_04_24_65_30_03	---	0006	---
		Output Data	---	0000	---	0001	0006	20_04_24_22_30_03
DRT2-ROS16	None	Output Data	---	0000	---	0002 (hexadecimal)	0006	20_04_24_23_30_03
		Generic Status	0001 (hexadecimal)	0006	20_04_24_64_30_03	---	0000	---
DRT2-ROS16	XWT-ID08(-1)	Output Data	---	0000	---	0002 (hexadecimal)	0006	20_04_24_23_30_03
		Input Data	0001 (hexadecimal)	0006	20_04_24_04_30_03	---	0000	---
		Generic Status	0001 (hexadecimal)	0006	20_04_24_64_30_03	---	0000	---
		Input Data + Generic Status	0002 (hexadecimal)	0006	20_04_24_65_30_03	---	0000	---

Model		Name	Produced connection size	Produced connection path length	Produced connection path	Consumed connection size	Consumed connection path length	Consumed connection path
Basic Unit	Expansion Unit							
DRT2-ROS16	XWT-ID16(-1)	Output Data	---	0000	---	0002 (hexadecimal)	0006	20_04_24_23_30_03
		Input Data	0002 (hexadecimal)	0006	20_04_24_05_30_03	---	0000	---
		Generic Status	0001 (hexadecimal)	0006	20_04_24_64_30_03	---	0000	---
		Input Data + Generic Status	0003 (hexadecimal)	0006	20_04_24_66_30_03	---	0000	---
DRT2-ROS16(-1)	XWT-OD08(-1)	Output Data	---	0000	---	0003 (hexadecimal)	0006	20_04_24_25_30_03
		Generic Status	0001 (hexadecimal)	0006	20_04_24_64_30_03	---	0000	---
DRT2-ROS16(-1)	XWT-OD16(-1)	Output Data	---	0000	---	0004 (hexadecimal)	0006	20_04_24_24_30_03
		Generic Status	0001 (hexadecimal)	0006	20_04_24_64_30_03	---	0000	---
DRT2-ID16TA(-1)		Input Data	0002 (hexadecimal)	0006	20_04_24_05_30_03	---	0000	---
		Generic Status	0001 (hexadecimal)	0006	20_04_24_64_30_03	---	0000	---
		Input Data + Generic Status	0003 (hexadecimal)	0006	20_04_24_66_30_03	---	0000	---
DRT2-OD16TA(-1)		Output Data	---	0000	---	0002 (hexadecimal)	0006	20_04_24_23_30_03
		Generic Status	0001 (hexadecimal)	0006	20_04_24_64_30_03	---	0000	---
DRT2-MD16TA(-1)		Input Data	0001 (hexadecimal)	0006	20_04_24_04_30_03	---	0000	---
		Generic Status	0001 (hexadecimal)	0006	20_04_24_64_30_03	---	0000	---
		Input Data + Generic Status	0002 (hexadecimal)	0006	20_04_24_65_30_03	---	0000	---
		Output Data	---	0000	---	0001 (hexadecimal)	0006	20_04_24_22_30_03
DRT2-ID16S(-1)		Input Data	0002 (hexadecimal)	0006	20_04_24_05_30_03	---	0000	---
		Generic Status	0001 (hexadecimal)	0006	20_04_24_64_30_03	---	0000	---
		Input Data + Generic Status	0003 (hexadecimal)	0006	20_04_24_66_30_03	---	0000	---
DRT2-MD16S(-1)		Input Data	0001 (hexadecimal)	0006	20_04_24_04_30_03	---	0000	---
		Generic Status	0001 (hexadecimal)	0006	20_04_24_64_30_03	---	0000	---
		Input Data + Generic Status	0002 (hexadecimal)	0006	20_04_24_65_30_03	---	0000	---
		Output Data	---	0000	---	0001 (hexadecimal)	0006	20_04_24_22_30_03

Model		Name	Produced connection size	Produced connection path length	Produced connection path	Consumed connection size	Consumed connection path length	Consumed connection path
Basic Unit	Expansion Unit							
DRT2-ID16SL(-1)		Input Data	0002 (hexadecimal)	0006	20_04_24_05_30_03	---	0000	---
		Generic Status	0001 (hexadecimal)	0006	20_04_24_64_30_03	---	0000	---
		Input Data + Generic Status	0003 (hexadecimal)	0006	20_04_24_66_30_03	---	0000	---
DRT2-ID16SLH(-1)		Input Data	0002 (hexadecimal)	0006	20_04_24_05_30_03	---	0000	---
		Generic Status	0001 (hexadecimal)	0006	20_04_24_64_30_03	---	0000	---
		Input Data + Generic Status	0003 (hexadecimal)	0006	20_04_24_66_30_03	---	0000	---
DRT2-ID16ML(X)(-1)		Input Data	0002 (hexadecimal)	0006	20_04_24_05_30_03	---	0000	---
		Generic Status	0001 (hexadecimal)	0006	20_04_24_64_30_03	---	0000	---
		Input Data + Generic Status	0003 (hexadecimal)	0006	20_04_24_66_30_03	---	0000	---
DRT2-ID32ML(-1)		Input Data	0004 (hexadecimal)	0006	20_04_24_06_30_03	---	0000	---
		Generic Status	0001 (hexadecimal)	0006	20_04_24_64_30_03	---	0000	---
		Input Data + Generic Status	0005 (hexadecimal)	0006	20_04_24_68_30_03	---	0000	---
DRT2-OD16ML(X)(-1)		Output Data	---	0000	---	---	---	20_04_24_23_30_03
		Generic Status	0001 (hexadecimal)	0006	20_04_24_64_30_03	---	---	---
DRT2-OD16SL(-1)		Output Data	---	0000	---	---	---	20_04_24_23_30_03
		Generic Status	0001 (hexadecimal)	0006	20_04_24_64_30_03	---	---	---
DRT2-OD16SLH(-1)		Output Data	---	0000	---	---	---	20_04_24_23_30_03
		Generic Status	0001 (hexadecimal)	0006	20_04_24_64_30_03	---	---	---
DRT2-OD32ML(-1)		Output Data	---	0000	---	0004 (hexadecimal)	0006	20_04_24_24_30_03
		Generic Status	0001 (hexadecimal)	0006	20_04_24_64_30_03	---	0000	---
DRT2-MD32ML(-1)		Input Data	0002 (hexadecimal)	0006	20_04_24_05_30_03	---	0000	---
		Generic Status	0001 (hexadecimal)	0006	20_04_24_64_30_03	---	0000	---
		Input Data + Generic Status	0003 (hexadecimal)	0006	20_04_24_66_30_03	---	0000	---
		Output Data	---	0000	---	0002 (hexadecimal)	0006	20_04_24_23_30_03

Model		Name	Produced connection size	Produced connection path length	Produced connection path	Consumed connection size	Consumed connection path length	Consumed connection path
Basic Unit	Expansion Unit							
DRT2-ID32B(-1)		Input Data	0004 (hexadecimal)	0006	20_04_24_06_30_03	---	0000	---
		Generic Status	0001 (hexadecimal)	0006	20_04_24_64_30_03	---	0000	---
		Input Data + Generic Status	0005 (hexadecimal)	0006	20_04_24_68_30_03	---	0000	---
DRT2-OD32B(-1)		Output Data	---	0000	---	0004	0006	20_04_24_23_30_03
		Generic Status	0001 (hexadecimal)	0006	20_04_24_64_30_03	---	0000	---
DRT2-MD32B(-1)		Input Data	0002 (hexadecimal)	0006	20_04_24_05_30_03	---	0000	---
		Generic Status	0001 (hexadecimal)	0006	20_04_24_64_30_03	---	0000	---
		Input Data + Generic Status	0003 (hexadecimal)	0006	20_04_24_66_30_03	---	0000	---
		Output Data	---	0000	---	0002	0006	20_04_24_23_30_03
DRT2-ID32BV(-1)		Input Data	0002 (hexadecimal)	0006	20_04_24_05_30_03	---	0000	---
		Generic Status	0001 (hexadecimal)	0006	20_04_24_64_30_03	---	0000	---
		Input Data + Generic Status	0003 (hexadecimal)	0006	20_04_24_66_30_03	---	0000	---
DRT2-OD32BV(-1)		Output Data	---	0000	---	0004	0006	20_04_24_30_30_03
		Generic Status	0001 (hexadecimal)	0006	20_04_24_64_30_03	---	0000	---
DRT2-MD32BV(-1)		Input Data	0002 (hexadecimal)	0006	20_04_24_05_30_03	---	0000	---
		Generic Status	0001 (hexadecimal)	0006	20_04_24_64_30_03	---	0000	---
		Input Data + Generic Status	0003 (hexadecimal)	0006	20_04_24_66_30_03	---	0000	---
		Output Data	---	0000	---	0002	0006	20_04_24_23_30_03
DRT2-ID32SL(-1)		Input Data	0004 (hexadecimal)	0006	20_04_24_06_30_03	---	0000	---
		Generic Status	0001 (hexadecimal)	0006	20_04_24_64_30_03	---	0000	---
		Input Data + Generic Status	0005 (hexadecimal)	0006	20_04_24_68_30_03	---	0000	---
DRT2-OD32SL(-1)		Output Data	---	0000	---	0004 (hexadecimal)	0006	20_04_24_24_30_03
		Generic Status	0001 (hexadecimal)	0006	20_04_24_64_30_03	---	0000	---

Model		Name	Produced connection size	Produced connection path length	Produced connection path	Consumed connection size	Consumed connection path length	Consumed connection path
Basic Unit	Expansion Unit							
DRT2-MD32SL(-1)		Input Data	0002 (hexadecimal)	0006	20_04_24_05_30_03	---	0000	---
		Generic Status	0001 (hexadecimal)	0006	20_04_24_64_30_03	---	0000	---
		Input Data + Generic Status	0003 (hexadecimal)	0006	20_04_24_66_30_03	---	0000	---
		Output Data	---	0000	---	0002 (hexadecimal)	0006	20_04_24_23_30_03
DRT2-ID32SLH(-1)		Input Data	0004 (hexadecimal)	0006	20_04_24_06_30_03	---	0000	---
		Generic Status	0001 (hexadecimal)	0006	20_04_24_64_30_03	---	0000	---
		Input Data + Generic Status	0005 (hexadecimal)	0006	20_04_24_68_30_03	---	0000	---
DRT2-OD32SLH(-1)		Output Data	---	0000	---	0004 (hexadecimal)	0006	20_04_24_24_30_03
		Generic Status	0001 (hexadecimal)	0006	20_04_24_64_30_03	---	0000	---
DRT2-MD32SLH(-1)		Input Data	0002 (hexadecimal)	0006	20_04_24_05_30_03	---	0000	---
		Generic Status	0001 (hexadecimal)	0006	20_04_24_64_30_03	---	0000	---
		Input Data + Generic Status	0003 (hexadecimal)	0006	20_04_24_66_30_03	---	0000	---
		Output Data	---	0000	---	0002 (hexadecimal)	0006	20_04_24_23_30_03
DRT2-HD16C(-1)		Input Data	0002 (hexadecimal)	0006	20_04_24_05_30_03	---	0000	---
		Generic Status	0001 (hexadecimal)	0006	20_04_24_64_30_03	---	0000	---
		Input Data + Generic Status	0003 (hexadecimal)	0006	20_04_24_66_30_03	---	0000	---
DRT2-ID08C(-1)		Input Data	0001 (hexadecimal)	0006	20_04_24_04_30_03	---	0000	---
		Generic Status	0001 (hexadecimal)	0006	20_04_24_64_30_03	---	0000	---
		Input Data + Generic Status	0002 (hexadecimal)	0006	20_04_24_65_30_03	---	0000	---
DRT2-OD08C(-1)		Output Data	---	0000	---	0001 (hexadecimal)	0006	20_04_24_22_30_03
		Generic Status	0001 (hexadecimal)	0006	20_04_24_64_30_03	---	0000	---
DRT2-ID04C(-1)		Input Data	0001 (hexadecimal)	0006	20_04_24_03_30_03	---	0000	---
		Generic Status	0001 (hexadecimal)	0006	20_04_24_64_30_03	---	0000	---
		Input Data + Generic Status	0002 (hexadecimal)	0006	20_04_24_65_30_03	---	0000	---

Model		Name	Produced connection size	Produced connection path length	Produced connection path	Consumed connection size	Consumed connection path length	Consumed connection path
Basic Unit	Expansion Unit							
DRT2-HD16CL(-1)		Input Data	0002 (hexadecimal)	0006	20_04_24_05_30_03	---	0000	---
		Generic Status	0001 (hexadecimal)	0006	20_04_24_64_30_03	---	0000	---
		Input Data + Generic Status	0003 (hexadecimal)	0006	20_04_24_66_30_03	---	0000	---
DRT2-ID08CL(-1)		Input Data	0001 (hexadecimal)	0006	20_04_24_04_30_03	---	0000	---
		Generic Status	0001 (hexadecimal)	0006	20_04_24_64_30_03	---	0000	---
		Input Data + Generic Status	0001 (hexadecimal)	0006	20_04_24_04_30_03	---	0000	---
DRT2-OD04CL(-1)		Output Data	---	0000	---	---	0000	20_04_24_21_30_03
		Generic Status	0001 (hexadecimal)	0006	20_04_24_64_30_03	---	0000	---
DRT2-OD08CL(-1)		Output Data	0001 (hexadecimal)	0006	20_04_24_04_30_03	---	0000	---
		Generic Status	0001 (hexadecimal)	0006	20_04_24_64_30_03	---	0000	---
DRT2-WD16CL(-1)		Output Data	---	0000	---	0002	0006	20_04_24_23_30_03
		Generic Status	0001 (hexadecimal)	0006	20_04_24_64_30_03	---	0000	---
DRT2-MD16CL(-1)		Input Data	0001 (hexadecimal)	0006	20_04_24_04_30_03	---	0000	---
		Generic Status	0001 (hexadecimal)	0006	20_04_24_64_30_03	---	0000	---
		Input Data + Generic Status	0002 (hexadecimal)	0006	20_04_24_65_30_03	---	0000	---
		Output Data	---	0000	---	0001	0006	20_04_24_22_30_03
DRT2-AD04 DRT2-AD04H		Analog Data 1	0008 (hexadecimal)	0006	20_04_24_68_30_03	0000 (hexadecimal)	0000	---
		Analog Data 2	0008 (hexadecimal)	0006	20_04_24_72_30_03	0000 (hexadecimal)	0000	---
		Generic Status	0001 (hexadecimal)	0006	20_04_24_79_30_03	0000 (hexadecimal)	0000	---
		Top and Valley shot	0002 (hexadecimal)	0006	20_04_24_7A_30_03	0000 (hexadecimal)	0000	---
		Analog Status	0004 (hexadecimal)	0006	20_04_24_86_30_03	0000 (hexadecimal)	0000	---

Model		Name	Produced connection size	Produced connection path length	Produced connection path	Consumed connection size	Consumed connection path length	Consumed connection path
Basic Unit	Expansion Unit							
DRT2-AD04 DRT2-AD04H		Analog data 1 + Analog data 2	0010 (hexadecimal)	0006	20_04_24_90_30_03	0000 (hexadecimal)	0000	---
		Top and Valley shot + Generic status	0003 (hexadecimal)	0006	20_04_24_97_30_03	0	0000	---
		Analog Status + Generic status	0005 (hexadecimal)	0006	20_04_24_A4_30_03	0	0000	---
		Analog data 1 + Top and valley shot	000A (hexadecimal)	0006	20_04_24_AE_30_03	0	0000	---
		Analog data 1 + Top and valley shot + generic status	000B (hexadecimal)	0006	20_04_24_B8_30_03	0	0000	---
		Hold control	0000 (hexadecimal)	0000	---	1	0006	20_04_24_BE_30_03
DRT2-DA02		Generic Status	0001 (hexadecimal)	0006	20_04_24_79_30_03	---	---	---
		Analog Data	---	0006	---	4	0006	20_04_24_C0_30_03



Model		Name	Produced connection size	Produced connection path length	Produced connection path	Consumed connection size	Consumed connection path length	Consumed connection path
Basic Unit	Expansion Unit							
DRT2-TS04T DRT2-TS04P		Temperature Data 1 (Normal)	0008	0006	20_04_24_68_30_03	0000	0000	---
		Temperature Data 1 (1/100 display)	0010	0006	20_04_24_6C_30_03	0000	0000	---
		Temperature Data 2 (Normal)	0008	0006	20_04_24_72_30_03	0000	0000	---
		Temperature Data 2 (1/100 display)	0010	0006	20_04_24_76_30_03	0000	0000	---
		Generic Status	0001	0006	20_04_24_79_30_03	0000	0000	---
		Top and Valley shot	0002	0006	20_04_24_7A_30_03	0000	0000	---
		Analog Status	0004	0006	20_04_24_86_30_03	0000	0000	---
		Temperature data 1 + Temperature data 2 (Normal)	0010	0006	20_04_24_90_30_03	0000	0000	---
		Temperature data 1 + Temperature data 2 (1/100 display)	0020	0006	20_04_24_94_30_03	0000	0000	---
		Top and Valley shot + Generic Status	0003	0006	20_04_24_97_30_03	0000	0000	---
		Analog Status + Generic Status	0005	0006	20_04_24_A4_30_03	0000	0000	---

Model		Name	Produced connection size	Produced connection path length	Produced connection path	Consumed connection size	Consumed connection path length	Consumed connection path
Basic Unit	Expansion Unit							
DRT2-TS04T DRT2-TS04P		Temperature data 1 (Normal) + Top and Valley shot	000A	0006	20_04_24_AE_30_03	0000	0000	---
		Temperature data 1 (1/100 display) + Top and Valley shot	0012	0006	20_04_24_B2_30_03	0000	0000	---
		Temperature data 1 (Normal) + Top and Valley shot + Generic Status	000B	0006	20_04_24_B8_30_03	0000	0000	---
		Temperature data 1 (1/100 display) + Top and Valley shot + Generic Status	0013	0006	20_04_24_BC_30_03	0000	0000	---
		Hold control	0000	0000	---	0001	0006	20_04_24_BE_30_03

Object instance 3	Section	Information		Maximum number of instances		
	Instance type	Explicit Message		1		
	Production trigger	Cyclic				
	Transport type	Server				
	Transport class	2				
Attribute	ID	Contents	Get (read)	Set (write)	Value	
	1	State	Yes	No	---	
	2	Instance type	Yes	No	01 (hexadecimal)	
	3	Transport class trigger	Yes	No	82 (hexadecimal)	
	4	Produced connection ID	Yes	No	---	
	5	Consumed connection ID	Yes	No	---	
	6	Initial comm. characteristics	Yes	No	02 (hexadecimal)	
	7	Produced connection size	Yes	No	See note.	
	8	Consumed connection size	Yes	No	0800 (hexadecimal)	
	9	Expected packet rate	Yes	Yes	---	
	12	Watchdog time-out action	Yes	No	00 (hexadecimal)	
	13	Produced connection path length	Yes	No	See note.	
	14	Produced connection path	Yes	No	See note.	
	15	Consumed connection path length	Yes	No	0000	
	16	Consumed connection path	Yes	No	See note.	
	Service	DeviceNet service		Parameter option		
05		Reset	None			
0E		Get_Attribute_Single	None			
10		Set_Attribute_Single	None			

**Note** The produced connection path and its length and the consumed connection path and its length depend on the type of Slave being used, as shown in the following table.

Model		Name	Produced connection size	Produced connection path length	Produced connection path	Consumed connection path length	Consumed connection path
Basic Unit	Expansion Unit						
DRT2-ID08(-1)		Input Data	0002 (hexadecimal)	0006	20_04_24_04_30_03	0000	---
		Generic Status	0001 (hexadecimal)	0006	20_04_24_64_30_03	0000	---
		Input Data + Generic Status	0003 (hexadecimal)	0006	20_04_24_65_30_03	0000	---
DRT2-ID16(-1)		Input Data	0002 (hexadecimal)	0006	20_04_24_05_30_03	0000	---
		Generic Status	0001 (hexadecimal)	0006	20_04_24_64_30_03	0000	---
		Input Data + Generic Status	0003 (hexadecimal)	0006	20_04_24_66_30_03	0000	---
DRT2-ID16(-1)		Input Data	0003 (hexadecimal)	0006	20_04_24_07_30_03	0000	---
		Generic Status	0001 (hexadecimal)	0006	20_04_24_64_30_03	0000	---
		Input Data + Generic Status	0004 (hexadecimal)	0006	20_04_24_67_30_03	0000	---
DRT2-ID16(-1)		Input Data	0004 (hexadecimal)	0006	20_04_24_06_30_03	0000	---
		Generic Status	0001 (hexadecimal)	0006	20_04_24_64_30_03	0000	---
		Input Data + Generic Status	0005 (hexadecimal)	0006	20_04_24_68_30_03	0000	---
DRT2-ID16(-1)		Input Data	0002 (hexadecimal)	0006	20_04_24_05_30_03	0000	---
		Generic Status	0001 (hexadecimal)	0006	20_04_24_64_30_03	0000	---
		Input Data + Generic Status	0003 (hexadecimal)	0006	20_04_24_66_30_03	0000	---
		Output Data	---	0000	---	0006	---
DRT2-ID16(-1)		Input Data	0002 (hexadecimal)	0006	20_04_24_05_30_03	0000	---
		Generic Status	0001 (hexadecimal)	0006	20_04_24_64_30_03	0000	---
		Input Data + Generic Status	0003 (hexadecimal)	0006	20_04_24_66_30_03	0000	---
		Output Data	---	0000	---	0006	---
DRT2-OD08(-1)		Output Data	---	0000	20_04_24_22_30_03	0000	---
		Generic Status	0001 (hexadecimal)	0006	20_04_24_64_30_03	0000	---
DRT2-OD16(-1)		Output Data	---	0000	---	0006	---
		Generic Status	0001 (hexadecimal)	0006	20_04_24_64_30_03	0000	---

Model		Name	Produced connection size	Produced connection path length	Produced connection path	Consumed connection path length	Consumed connection path
Basic Unit	Expansion Unit						
DRT2-OD16(-1)	XWT-ID08(-1)	Output Data	---	0000	---	0006	---
		Input Data	0001 (hexadecimal)	0006	20_04_24_04_30_03	0000	---
		Generic Status	0001 (hexadecimal)	0006	20_04_24_64_30_03	0000	---
		Input Data + Generic Status	0002 (hexadecimal)	0006	20_04_24_65_30_03	0000	---
DRT2-OD16(-1)	XWT-ID16(-1)	Output Data	---	0000		0006	---
		Input Data	0002 (hexadecimal)	0006	20_04_24_05_30_03	0000	---
		Generic Status	0001 (hexadecimal)	0006	20_04_24_64_30_03	0000	---
		Input Data + Generic Status	0003 (hexadecimal)	0006	20_04_24_66_30_03	0000	---
DRT2-OD16(-1)	XWT-OD08(-1)	Output Data	---	0000	---	0006	---
		Generic Status	0001 (hexadecimal)	0006	20_04_24_64_30_03	0000	---
DRT2-OD16(-1)	XWT-OD16(-1)	Output Data	---	0000	---	0006	---
		Generic Status	0001 (hexadecimal)	0006	20_04_24_64_30_03	0000	---
DRT2-MD16(-1)		Input Data	0002 (hexadecimal)	0006	20_04_24_04_30_03	0000	---
		Generic Status	0001 (hexadecimal)	0006	20_04_24_64_30_03	0000	---
		Input Data + Generic Status	0003 (hexadecimal)	0006	20_04_24_65_30_03	0000	---
		Output Data	---	0000	---	0000	---
DRT2-ROS16	None	Output Data	---	0000	---	0000	---
		Generic Status	0001 (hexadecimal)	0006	20_04_24_64_30_03	0000	---
DRT2-ROS16	XWT-ID08(-1)	Output Data	---	0000	---	0000	---
		Input Data	0001 (hexadecimal)	0006	20_04_24_04_30_03	0000	---
		Generic Status	0001 (hexadecimal)	0006	20_04_24_64_30_03	0000	---
		Input Data + Generic Status	0002 (hexadecimal)	0006	20_04_24_65_30_03	0000	---
DRT2-ROS16	XWT-ID16(-1)	Output Data	---	0000	---	0000	---
		Input Data	0002 (hexadecimal)	0006	20_04_24_05_30_03	0000	---
		Generic Status	0001 (hexadecimal)	0006	20_04_24_64_30_03	0000	---
		Input Data + Generic Status	0003 (hexadecimal)	0006	20_04_24_66_30_03	0000	---
DRT2-ROS16(-1)	XWT-OD08(-1)	Output Data	---	0000	---	0000	---
		Generic Status	0001 (hexadecimal)	0006	20_04_24_64_30_03	0000	---

Model		Name	Produced connection size	Produced connection path length	Produced connection path	Consumed connection path length	Consumed connection path
Basic Unit	Expansion Unit						
DRT2-ROS16(-1)	XWT-OD16(-1)	Output Data	---	0000	---	0000	---
		Generic Status	0001 (hexadecimal)	0006	20_04_24_64_30_03	0000	---
DRT2-ID16TA(-1)		Input Data	0002 (hexadecimal)	0006	20_04_24_05_30_03	0000	---
		Generic Status	0001 (hexadecimal)	0006	20_04_24_64_30_03	0000	---
		Input Data + Generic Status	0003 (hexadecimal)	0006	20_04_24_66_30_03	0000	---
DRT2-OD16TA(-1)		Output Data	---	0000	---	0000	---
		Generic Status	0001 (hexadecimal)	0006	20_04_24_64_30_03	0000	---
DRT2-MD16TA(-1)		Input Data	0001 (hexadecimal)	0006	20_04_24_04_30_03	0000	---
		Generic Status	0001 (hexadecimal)	0006	20_04_24_64_30_03	0000	---
		Input Data + Generic Status	0002 (hexadecimal)	0006	20_04_24_65_30_03	0000	---
		Output Data	---	0000	---	0000	---
DRT2-ID16S(-1)		Input Data	0002 (hexadecimal)	0006	20_04_24_05_30_03	0000	---
		Generic Status	0001 (hexadecimal)	0006	20_04_24_64_30_03	0000	---
		Input Data + Generic Status	0003 (hexadecimal)	0006	20_04_24_66_30_03	0000	---
DRT2-MD16S(-1)		Input Data	0001 (hexadecimal)	0006	20_04_24_04_30_03	0000	---
		Generic Status	0001 (hexadecimal)	0006	20_04_24_64_30_03	0000	---
		Input Data + Generic Status	0002 (hexadecimal)	0006	20_04_24_65_30_03	0000	---
		Output Data	---	0000	---	0000	---
DRT2-ID16ML(X)(-1)		Input Data	0002 (hexadecimal)	0006	20_04_24_05_30_03	0000	---
		Generic Status	0001 (hexadecimal)	0006	20_04_24_64_30_03	0000	---
		Input Data + Generic Status	0003 (hexadecimal)	0006	20_04_24_66_30_03	0000	---
DRT2-ID16SL (-1)		Input Data	0002 (hexadecimal)	0006	20_04_24_05_30_03	0000	---
		Generic Status	0001 (hexadecimal)	0006	20_04_24_64_30_03	0000	---
		Input Data + Generic Status	0003 (hexadecimal)	0006	20_04_24_66_30_03	0000	---

Model		Name	Produced connection size	Produced connection path length	Produced connection path	Consumed connection path length	Consumed connection path
Basic Unit	Expansion Unit						
DRT2-ID16SLH (-1)		Input Data	0002 (hexadecimal)	0006	20_04_24_05_30_03	0000	---
		Generic Status	0001 (hexadecimal)	0006	20_04_24_64_30_03	0000	---
		Input Data + Generic Status	0003 (hexadecimal)	0006	20_04_24_66_30_03	0000	---
DRT2-ID32ML(-1)		Input Data	0004 (hexadecimal)	0006	20_04_24_06_30_03	0000	---
		Generic Status	0001 (hexadecimal)	0006	20_04_24_64_30_03	0000	---
		Input Data + Generic Status	0005 (hexadecimal)	0006	20_04_24_68_30_03	0000	---
DRT2-OD16SL(-1)		Output Data	---	0000	---	0000	---
		Generic Status	0001 (hexadecimal)	0006	20_04_24_64_30_03	0000	---
DRT2-OD16SLH(-1)		Output Data	---	0000	---	0000	---
		Generic Status	0001 (hexadecimal)	0006	20_04_24_64_30_03	0000	---
DRT2-OD16ML(x)(-1)		Output Data	---	0000	---	0000	---
		Generic Status	0001 (hexadecimal)	0006	20_04_24_64_30_03	0000	---
DRT2-OD32ML(-1)		Output Data	---	0000	---	0000	---
		Generic Status	0001 (hexadecimal)	0006	20_04_24_64_30_03	0000	---
DRT2-MD32ML(-1)		Input Data	0002 (hexadecimal)	0006	20_04_24_05_30_03	0000	---
		Generic Status	0001 (hexadecimal)	0006	20_04_24_64_30_03	0000	---
		Input Data + Generic Status	0003 (hexadecimal)	0006	20_04_24_66_30_03	0000	---
		Output Data	---	0000	---	0000	---
DRT2-ID32B(-1)		Input Data	0004 (hexadecimal)	0006	20_04_24_06_30_03	0000	---
		Generic Status	0001 (hexadecimal)	0006	20_04_24_64_30_03	0000	---
		Input Data + Generic Status	0005 (hexadecimal)	0006	20_04_24_68_30_03	0000	---
DRT2-OD32B(-1)		Output Data	---	0000	---	0000	---
		Generic Status	0001 (hexadecimal)	0006	20_04_24_64_30_03	0000	---
DRT2-MD32B(-1)		Input Data	0002 (hexadecimal)	0006	20_04_24_05_30_03	0000	---
		Generic Status	0001 (hexadecimal)	0006	20_04_24_64_30_03	0000	---
		Input Data + Generic Status	0003 (hexadecimal)	0006	20_04_24_66_30_03	0000	---
		Output Data	---	0000	---	0000	---

Model		Name	Produced connection size	Produced connection path length	Produced connection path	Consumed connection path length	Consumed connection path
Basic Unit	Expansion Unit						
DRT2-ID32BV(-1)		Input Data	0004 (hexadecimal)	0006	20_04_24_06_30_03	0000	---
		Generic Status	0001 (hexadecimal)	0006	20_04_24_64_30_03	0000	---
		Input Data + Generic Status	0005 (hexadecimal)	0006	20_04_24_68_30_03	0000	---
DRT2-OD32BV(-1)		Output Data	---	0000	---	0000	---
		Generic Status	0001 (hexadecimal)	0006	20_04_24_64_30_03	0000	---
DRT2-MD32BV(-1)		Input Data	0002 (hexadecimal)	0006	20_04_24_05_30_03	0000	---
		Generic Status	0001 (hexadecimal)	0006	20_04_24_64_30_03	0000	---
		Input Data + Generic Status	0003 (hexadecimal)	0006	20_04_24_66_30_03	0000	---
		Output Data	---	0000	---	0000	---
DRT2-ID32SL(-1)		Input Data	0004 (hexadecimal)	0006	20_04_24_06_30_03	0000	---
		Generic Status	0001 (hexadecimal)	0006	20_04_24_64_30_03	0000	---
		Input Data + Generic Status	0005 (hexadecimal)	0006	20_04_24_68_30_03	0000	---
DRT2-OD32SL(-1)		Output Data	---	0000	---	0000	---
		Generic Status	0001 (hexadecimal)	0006	20_04_24_64_30_03	0000	---
DRT2-MD32SL(-1)		Input Data	0002 (hexadecimal)	0006	20_04_24_05_30_03	0000	---
		Generic Status	0001 (hexadecimal)	0006	20_04_24_64_30_03	0000	---
		Input Data + Generic Status	0003 (hexadecimal)	0006	20_04_24_66_30_03	0000	---
		Output Data	---	0000	---	0000	---
DRT2-ID32SLH(-1)		Input Data	0004 (hexadecimal)	0006	20_04_24_06_30_03	0000	---
		Generic Status	0001 (hexadecimal)	0006	20_04_24_64_30_03	0000	---
		Input Data + Generic Status	0005 (hexadecimal)	0006	20_04_24_68_30_03	0000	---
DRT2-OD32SLH(-1)		Output Data	---	0000	---	0000	---
		Generic Status	0001 (hexadecimal)	0006	20_04_24_64_30_03	0000	---
DRT2-MD32SLH(-1)		Input Data	0002 (hexadecimal)	0006	20_04_24_05_30_03	0000	---
		Generic Status	0001 (hexadecimal)	0006	20_04_24_64_30_03	0000	---
		Input Data + Generic Status	0003 (hexadecimal)	0006	20_04_24_66_30_03	0000	---
		Output Data	---	0000	---	0000	---



Model		Name	Produced connection size	Produced connection path length	Produced connection path	Consumed connection path length	Consumed connection path
Basic Unit	Expansion Unit						
DRT2-HD16C(-1)		Input Data	0002 (hexadecimal)	0006	20_04_24_05_30_03	0000	---
		Generic Status	0001 (hexadecimal)	0006	20_04_24_64_30_03	0000	---
		Input Data + Generic Status	0003 (hexadecimal)	0006	20_04_24_66_30_03	0000	---
DRT2-ID08C(-1)		Input Data	0001 (hexadecimal)	0006	20_04_24_04_30_03	0000	---
		Generic Status	0001 (hexadecimal)	0006	20_04_24_64_30_03	0000	---
		Input Data + Generic Status	0002 (hexadecimal)	0006	20_04_24_65_30_03	0000	---
DRT2-OD08C(-1)		Output Data	---	0000	---	0006	---
		Generic Status	0001 (hexadecimal)	0006	20_04_24_64_30_03	0000	---
DRT2-ID04CL(-1)		Input Data	0001 (hexadecimal)	0006	20_04_24_03_30_03	0000	---
		Generic Status	0001 (hexadecimal)	0006	20_04_24_64_30_03	0000	---
		Input Data + Generic Status	0002 (hexadecimal)	0006	20_04_24_65_30_03	0000	---
DRT2-HD16CL(-1)		Input Data	0002 (hexadecimal)	0006	20_04_24_05_30_03	0000	---
		Generic Status	0001 (hexadecimal)	0006	20_04_24_64_30_03	0000	---
		Input Data + Generic Status	0003 (hexadecimal)	0006	20_04_24_66_30_03	0000	---
DRT2-ID08CL(-1)		Input Data	0001 (hexadecimal)	0006	20_04_24_04_30_03	0000	---
		Generic Status	0001 (hexadecimal)	0006	20_04_24_64_30_03	0000	---
		Input Data + Generic Status	0002 (hexadecimal)	0006	20_04_24_65_30_03	0000	---
DRT2-WD16CL(-1)		Output Data	---	0000	---	0000	---
		Generic Status	0001 (hexadecimal)	0006	20_04_24_64_30_03	0000	---
DRT2-OD04CL(-1)		Output Data	---	0000	---	0000	---
		Generic Status	0001 (hexadecimal)	0006	20_04_24_64_30_03	0000	---
DRT2-OD08CL(-1)		Output Data	---	0000	---	0000	---
		Generic Status	0001 (hexadecimal)	0006	20_04_24_64_30_03	0000	---

Model		Name	Produced connection size	Produced connection path length	Produced connection path	Consumed connection path length	Consumed connection path
Basic Unit	Expansion Unit						
DRT2-MD16CL(-1)		Input Data	0001 (hexadecimal)	0006	20_04_24_04_30_03	0000	---
		Generic Status	0001 (hexadecimal)	0006	20_04_24_64_30_03	0000	---
		Input Data + Generic Status	0002 (hexadecimal)	0006	20_04_24_65_30_03	0000	---
		Output Data	---	0000	---	0000	---
DRT2-AD04 DRT2-AD04		Analog Data 1	0008 (hexadecimal)	0006	20_04_24_68_30_03	0000	---
		Analog Data 2	0008 (hexadecimal)	0006	20_04_24_72_30_03	0000	---
		Generic Status	0001 (hexadecimal)	0006	20_04_24_79_30_03	0000	---
		Top and Valley shot	0002 (hexadecimal)	0006	20_04_24_7A_30_03	0000	---
		Analog Status	0004 (hexadecimal)	0006	20_04_24_86_30_03	0000	---
		Top and Valley shot + Generic status	0003 (hexadecimal)	0006	20_04_24_97_30_03	0000	---
		Analog Status + Generic status	0005 (hexadecimal)	0006	20_04_24_A4_30_03	0000	---
DRT2-DA02		Generic Status	0001 (hexadecimal)	0006	20_04_24_79_30_03	0000	---
DRT2-TS04T DRT2-TS04P		Temperature Data 1 (Normal)	0008	0006	20_04_24_68_30_03	0000	---
		Temperature Data 2 (Normal)	0008	0006	20_04_24_72_30_03	0000	---
		Generic Status	0001	0006	20_04_24_79_30_03	0000	---
		Top and Valley shot	0002	0006	20_04_24_7A_30_03	0000	---
		Analog Status	0004	0006	20_04_24_86_30_03	0000	---
		Top and Valley shot + Generic Status	0003	0006	20_04_24_97_30_03	0000	---
		Analog Status + Generic Status	0005	0006	20_04_24_A4_30_03	0000H	---

Object instance 4	<b>Section</b>	<b>Information</b>		<b>Maximum number of instances</b>		
	<b>Instance type</b>	COS Cyclic		1		
	<b>Production trigger</b>	Cyclic				
	<b>Transport type</b>	Server				
	<b>Transport class</b>	2				
	<b>Attribute</b>	<b>ID</b>	<b>Contents</b>	<b>Get (read)</b>	<b>Set (write)</b>	<b>Value</b>
		1	State	Yes	No	---
		2	Instance type	Yes	No	01 (hexadecimal)
		3	Transport class trigger	Yes	No	12
		4	Produced connection ID	Yes	No	---
		5	Consumed connection ID	Yes	No	---
		6	Initial comm. characteristics	Yes	No	01 (hexadecimal)
		7	Produced connection size	Yes	No	See note.
		8	Consumed connection size	Yes	No	00 (hexadecimal)
		9	Expected packet rate	Yes	Yes	00
		12	Watchdog time-out action	Yes	No	00
		13	Produced connection path length	Yes	No	See note.
		14	Produced connection path	Yes	No	See note.
		15	Consumed connection path length	Yes	No	0004 (hexadecimal)
		16	Consumed connection path	Yes	No	202B2401
	17	Production inhibit time	Yes	No	0000 (hexadecimal)	
	<b>Service</b>	<b>DeviceNet service</b>		<b>Parameter option</b>		
		05	Reset	None		
		0E	Get_Attribute_Single	None		
		10	Set_Attribute_Single	None		

**Note** The produced connection path and its length and the consumed connection path and its length depend on the type of Slave being used, as shown in the following table.

Model		Name	Produced connection size	Produced connection path length	Produced connection path	Consumed connection path length	Consumed connection path
Basic Unit	Expansion Unit						
DRT2-ID08(-1)		Input Data	0002 (hexadecimal)	0006	20_04_24_04_30_03	0000	---
		Generic Status	0001 (hexadecimal)	0006	20_04_24_64_30_03	0000	---
		Input Data + Generic Status	0003 (hexadecimal)	0006	20_04_24_65_30_03	0000	---
DRT2-ID16(-1)		Input Data	0002 (hexadecimal)	0006	20_04_24_05_30_03	0000	---
		Generic Status	0001 (hexadecimal)	0006	20_04_24_64_30_03	0000	---
		Input Data + Generic Status	0003 (hexadecimal)	0006	20_04_24_66_30_03	0000	---
DRT2-ID16(-1)		Input Data	0003 (hexadecimal)	0006	20_04_24_07_30_03	0000	---
		Generic Status	0001 (hexadecimal)	0006	20_04_24_64_30_03	0000	---
		Input Data + Generic Status	0004 (hexadecimal)	0006	20_04_24_67_30_03	0000	---
DRT2-ID16(-1)		Input Data	0004 (hexadecimal)	0006	20_04_24_06_30_03	0000	---
		Generic Status	0001 (hexadecimal)	0006	20_04_24_64_30_03	0000	---
		Input Data + Generic Status	0005 (hexadecimal)	0006	20_04_24_68_30_03	0000	---
DRT2-ID16(-1)		Input Data	0002 (hexadecimal)	0006	20_04_24_05_30_03	0000	---
		Generic Status	0001 (hexadecimal)	0006	20_04_24_64_30_03	0000	---
		Input Data + Generic Status	0003 (hexadecimal)	0006	20_04_24_66_30_03	0000	---
		Output Data	---	0000	---	0000	---
DRT2-ID16(-1)		Input Data	0002 (hexadecimal)	0006	20_04_24_05_30_03	0000	---
		Generic Status	0001 (hexadecimal)	0006	20_04_24_64_30_03	0000	---
		Input Data + Generic Status	0003 (hexadecimal)	0006	20_04_24_66_30_03	0000	---
		Output Data	---	0000	---	0000	---
DRT2-OD08(-1)		Output Data	---	0000	20_04_24_22_30_03	0000	---
		Generic Status	0001 (hexadecimal)	0006	20_04_24_64_30_03	0000	---
DRT2-OD16(-1)		Output Data	---	0000	---	0000	---
		Generic Status	0001 (hexadecimal)	0006	20_04_24_64_30_03	0000	---

Model		Name	Produced connection size	Produced connection path length	Produced connection path	Consumed connection path length	Consumed connection path
Basic Unit	Expansion Unit						
DRT2-OD16(-1)	XWT-ID08(-1)	Output Data	---	0000	---	0000	---
		Input Data	0001 (hexadecimal)	0006	20_04_24_04_30_03	0000	---
		Generic Status	0001 (hexadecimal)	0006	20_04_24_64_30_03	0000	---
		Input Data + Generic Status	0002 (hexadecimal)	0006	20_04_24_65_30_03	0000	---
DRT2-OD16(-1)	XWT-ID16(-1)	Output Data	---	0000	---	0000	---
		Input Data	0002 (hexadecimal)	0006	20_04_24_05_30_03	0000	---
		Generic Status	0001 (hexadecimal)	0006	20_04_24_64_30_03	0000	---
		Input Data + Generic Status	0003 (hexadecimal)	0006	20_04_24_66_30_03	0000	---
DRT2-OD16(-1)	XWT-OD08(-1)	Output Data	---	0000	---	0000	---
		Generic Status	0001 (hexadecimal)	0006	20_04_24_64_30_03	0000	---
DRT2-OD16(-1)	XWT-OD16(-1)	Output Data	---	0000	---	0000	---
		Generic Status	0001 (hexadecimal)	0006	20_04_24_64_30_03	0000	---
DRT2-MD16(-1)		Input Data	0002 (hexadecimal)	0006	20_04_24_04_30_03	0000	---
		Generic Status	0001 (hexadecimal)	0006	20_04_24_64_30_03	0000	---
		Input Data + Generic Status	0003 (hexadecimal)	0006	20_04_24_65_30_03	0000	---
		Output Data	---	0000	---	0000	---
DRT2-ROS16	None	Output Data	---	0000	---	0000	---
		Generic Status	0001 (hexadecimal)	0006	20_04_24_64_30_03	0000	---
DRT2-ROS16	XWT-ID08(-1)	Output Data	---	0000	-	0000	---
		Input Data	0001 (hexadecimal)	0006	20_04_24_04_30_03	0000	---
		Generic Status	0001 (hexadecimal)	0006	20_04_24_64_30_03	0000	---
		Input Data + Generic Status	0002 (hexadecimal)	0006	20_04_24_65_30_03	0000	---
DRT2-ROS16	XWT-ID16(-1)	Output Data	---	0000	---	0000	---
		Input Data	0002 (hexadecimal)	0006	20_04_24_05_30_03	0000	---
		Generic Status	0001 (hexadecimal)	0006	20_04_24_64_30_03	0000	---
		Input Data + Generic Status	0003 (hexadecimal)	0006	20_04_24_66_30_03	0000	---
DRT2-ROS16(-1)	XWT-OD08(-1)	Output Data	---	0000	---	0000	---
		Generic Status	0001 (hexadecimal)	0006	20_04_24_64_30_03	0000	---

Model		Name	Produced connection size	Produced connection path length	Produced connection path	Consumed connection path length	Consumed connection path
Basic Unit	Expansion Unit						
DRT2-ROS16(-1)	XWT-OD16(-1)	Output Data	---	0000	---	0000	---
		Generic Status	0001 (hexadecimal)	0006	20_04_24_64_30_03	0000	---
DRT2-ID16TA(-1)		Input Data	0002 (hexadecimal)	0006	20_04_24_05_30_03	0000	---
		Generic Status	0001 (hexadecimal)	0006	20_04_24_64_30_03	0000	---
		Input Data + Generic Status	0003 (hexadecimal)	0006	20_04_24_66_30_03	0000	---
DRT2-OD16TA(-1)		Output Data	---	0000	---	0000	---
		Generic Status	0001 (hexadecimal)	0006	20_04_24_64_30_03	0000	---
DRT2-MD16TA(-1)		Input Data	0001 (hexadecimal)	0006	20_04_24_04_30_03	0000	---
		Generic Status	0001 (hexadecimal)	0006	20_04_24_64_30_03	0000	---
		Input Data + Generic Status	0002 (hexadecimal)	0006	20_04_24_65_30_03	0000	---
		Output Data	---	0000	---	0000	---
DRT2-ID16S(-1)		Input Data	0002 (hexadecimal)	0006	20_04_24_05_30_03	0000	---
		Generic Status	0001 (hexadecimal)	0006	20_04_24_64_30_03	0000	---
		Input Data + Generic Status	0003 (hexadecimal)	0006	20_04_24_66_30_03	0000	---
DRT2-MD16S(-1)		Input Data	0001 (hexadecimal)	0006	20_04_24_04_30_03	0000	---
		Generic Status	0001 (hexadecimal)	0006	20_04_24_64_30_03	0000	---
		Input Data + Generic Status	0002 (hexadecimal)	0006	20_04_24_65_30_03	0000	---
		Output Data	---	0000	---	0000	---
DRT2-ID16ML(X)(-1)		Input Data	0002 (hexadecimal)	0006	20_04_24_05_30_03	0000	---
		Generic Status	0001 (hexadecimal)	0006	20_04_24_64_30_03	0000	---
		Input Data + Generic Status	0003 (hexadecimal)	0006	20_04_24_66_30_03	0000	---
DRT2-ID16SL(-1)		Input Data	0002 (hexadecimal)	0006	20_04_24_05_30_03	0000	---
		Generic Status	0001 (hexadecimal)	0006	20_04_24_64_30_03	0000	---
		Input Data + Generic Status	0003 (hexadecimal)	0006	20_04_24_66_30_03	0000	---

Model		Name	Produced connection size	Produced connection path length	Produced connection path	Consumed connection path length	Consumed connection path
Basic Unit	Expansion Unit						
DRT2-ID16SLH(-1)		Input Data	0002 (hexadecimal)	0006	20_04_24_05_30_03	0000	---
		Generic Status	0001 (hexadecimal)	0006	20_04_24_64_30_03	0000	---
		Input Data + Generic Status	0003 (hexadecimal)	0006	20_04_24_66_30_03	0000	---
DRT2-ID32ML(-1)		Input Data	0004 (hexadecimal)	0006	20_04_24_06_30_03	0000	---
		Generic Status	0001 (hexadecimal)	0006	20_04_24_64_30_03	0000	---
		Input Data + Generic Status	0005 (hexadecimal)	0006	20_04_24_68_30_03	0000	---
DRT2-OD16ML(X)(-1)		Output Data	---	0000	---	0000	---
		Generic Status	0001 (hexadecimal)	0006	20_04_24_64_30_03	0000	---
DRT2-OD16SL(-1)		Output Data	---	0000	---	0000	---
		Generic Status	0001 (hexadecimal)	0006	20_04_24_64_30_03	0000	---
DRT2-OD16SLH(-1)		Output Data	---	0000	---	0000	---
		Generic Status	0001 (hexadecimal)	0006	20_04_24_64_30_03	0000	---
DRT2-OD32ML(-1)		Output Data	---	0000	---	0000	---
		Generic Status	0001 (hexadecimal)	0006	20_04_24_64_30_03	0000	---
DRT2-MD32ML(-1)		Input Data	0002 (hexadecimal)	0006	20_04_24_05_30_03	0000	---
		Generic Status	0001 (hexadecimal)	0006	20_04_24_64_30_03	0000	---
		Input Data + Generic Status	0003 (hexadecimal)	0006	20_04_24_66_30_03	0000	---
		Output Data	---	0000	---	0000	---
DRT2-ID32B(-1)		Input Data	0004 (hexadecimal)	0006	20_04_24_06_30_03	0000	---
		Generic Status	0001 (hexadecimal)	0006	20_04_24_64_30_03	0000	---
		Input Data + Generic Status	0005 (hexadecimal)	0006	20_04_24_68_30_03	0000	---
DRT2-OD32B(-1)		Output Data	---	0000	---	0000	---
		Generic Status	0001 (hexadecimal)	0006	20_04_24_64_30_03	0000	---
DRT2-MD32B(-1)		Input Data	0002 (hexadecimal)	0006	20_04_24_05_30_03	0000	---
		Generic Status	0001 (hexadecimal)	0006	20_04_24_64_30_03	0000	---
		Input Data + Generic Status	0003 (hexadecimal)	0006	20_04_24_66_30_03	0000	---
		Output Data	---	0000	---	0000	---

Model		Name	Produced connection size	Produced connection path length	Produced connection path	Consumed connection path length	Consumed connection path
Basic Unit	Expansion Unit						
DRT2-ID32BV(-1)		Input Data	0004 (hexadecimal)	0006	20_04_24_06_30_03	0000	---
		Generic Status	0001 (hexadecimal)	0006	20_04_24_64_30_03	0000	---
		Input Data + Generic Status	0005 (hexadecimal)	0006	20_04_24_68_30_03	0000	---
DRT2-OD32BV(-1)		Output Data	---	0000	---	0000	---
		Generic Status	0001 (hexadecimal)	0006	20_04_24_64_30_03	0000	---
DRT2-MD32BV(-1)		Input Data	0002 (hexadecimal)	0006	20_04_24_05_30_03	0000	---
		Generic Status	0001 (hexadecimal)	0006	20_04_24_64_30_03	0000	---
		Input Data + Generic Status	0003 (hexadecimal)	0006	20_04_24_66_30_03	0000	---
		Output Data	---	0000	---	0000	---
DRT2-ID32SL(-1)		Input Data	0004 (hexadecimal)	0006	20_04_24_06_30_03	0000	---
		Generic Status	0001 (hexadecimal)	0006	20_04_24_64_30_03	0000	---
		Input Data + Generic Status	0005 (hexadecimal)	0006	20_04_24_68_30_03	0000	---
DRT2-OD32SL(-1)		Output Data	---	0000	---	0000	---
		Generic Status	0001 (hexadecimal)	0006	20_04_24_64_30_03	0000	---
DRT2-MD32ML(-1)		Input Data	0002 (hexadecimal)	0006	20_04_24_05_30_03	0000	---
		Generic Status	0001 (hexadecimal)	0006	20_04_24_64_30_03	0000	---
		Input Data + Generic Status	0003 (hexadecimal)	0006	20_04_24_66_30_03	0000	---
		Output Data	---	0000	---	0000	---
DRT2-ID32SLH(-1)		Input Data	0004 (hexadecimal)	0006	20_04_24_06_30_03	0000	---
		Generic Status	0001 (hexadecimal)	0006	20_04_24_64_30_03	0000	---
		Input Data + Generic Status	0005 (hexadecimal)	0006	20_04_24_68_30_03	0000	---
DRT2-OD32SLH(-1)		Output Data	---	0000	---	0000	---
		Generic Status	0001 (hexadecimal)	0006	20_04_24_64_30_03	0000	---
DRT2-MD32MLH(-1)		Input Data	0002 (hexadecimal)	0006	20_04_24_05_30_03	0000	---
		Generic Status	0001 (hexadecimal)	0006	20_04_24_64_30_03	0000	---
		Input Data + Generic Status	0003 (hexadecimal)	0006	20_04_24_66_30_03	0000	---
		Output Data	---	0000	---	0000	---



Model		Name	Produced connection size	Produced connection path length	Produced connection path	Consumed connection path length	Consumed connection path
Basic Unit	Expansion Unit						
DRT2-HD16C(-1)		Input Data	0002 (hexadecimal)	0006	20_04_24_05_30_03	0000	---
		Generic Status	0001 (hexadecimal)	0006	20_04_24_64_30_03	0000	---
		Input Data + Generic Status	0003 (hexadecimal)	0006	20_04_24_66_30_03	0000	---
DRT2-ID08C(-1)		Input Data	0001 (hexadecimal)	0006	20_04_24_04_30_03	0000	---
		Generic Status	0001 (hexadecimal)	0006	20_04_24_64_30_03	0000	---
		Input Data + Generic Status	0002 (hexadecimal)	0006	20_04_24_65_30_03	0000	---
DRT2-OD08C(-1)		Output Data	---	0000	---	0000	---
		Generic Status	0001 (hexadecimal)	0006	20_04_24_64_30_03	0000	---
DRT2-HD16CL(-1)		Input Data	0002 (hexadecimal)	0006	20_04_24_05_30_03	0000	---
		Generic Status	0001 (hexadecimal)	0006	20_04_24_64_30_03	0000	---
		Input Data + Generic Status	0003 (hexadecimal)	0006	20_04_24_66_30_03	0000	---
DRT2-ID08CL(-1)		Input Data	0001 (hexadecimal)	0006	20_04_24_04_30_03	0000	---
		Generic Status	0001 (hexadecimal)	0006	20_04_24_64_30_03	0000	---
		Input Data + Generic Status	0002 (hexadecimal)	0006	20_04_24_65_30_03	0000	---
DRT2-ID04CL(-1)		Input Data	0001 (hexadecimal)	0006	20_04_24_03_30_03	0000	---
		Generic Status	0001 (hexadecimal)	0006	20_04_24_64_30_03	0000	---
		Input Data + Generic Status	0002 (hexadecimal)	0006	20_04_24_65_30_03	0000	---
DRT2-WD16CL(-1)		Output Data	---	0000	---	0000	---
		Generic Status	0001 (hexadecimal)	0006	20_04_24_64_30_03	0000	---
DRT2-OD08CL(-1)		Output Data	---	0000	---	0000	---
		Generic Status	0001 (hexadecimal)	0006	20_04_24_64_30_03	0000	---
DRT2-OD04CL(-1)		Output Data	---	0000	---	0000	---
		Generic Status	0001 (hexadecimal)	0006	20_04_24_64_30_03	0000	---

Model		Name	Produced connection size	Produced connection path length	Produced connection path	Consumed connection path length	Consumed connection path
Basic Unit	Expansion Unit						
DRT2-MD16CL(-1)		Input Data	0001 (hexadecimal)	0006	20_04_24_04_30_03	0000	---
		Generic Status	0001 (hexadecimal)	0006	20_04_24_64_30_03	0000	---
		Input Data + Generic Status	0002 (hexadecimal)	0006	20_04_24_65_30_03	0000	---
		Output Data	---	0000	---	0000	---
DRT2-AD04 DRT2-AD04H		Analog Data 1	0008 (hexadecimal)	0006	20_04_24_68_30_03	0000	---
		Analog Data 2	0008 (hexadecimal)	0006	20_04_24_72_30_03	0000	---
		Generic Status	0001 (hexadecimal)	0006	20_04_24_79_30_03	0000	---
		Top and Valley shot	0002 (hexadecimal)	0006	20_04_24_7A_30_03	0000	---
		Analog Status	0004 (hexadecimal)	0006	20_04_24_86_30_03	0000	---
		Top and Valley shot + Generic status	0003 (hexadecimal)	0006	20_04_24_97_30_03	0000	---
		Analog Status + Generic status	0005 (hexadecimal)	0006	20_04_24_A4_30_03	0000	---
DRT2-AD04		Analog data 1 + Analog data 2	0010 (hexadecimal)	0006	20_04_24_90_30_03	0000	---
		Analog data 1 + Top and valley shot	000A (hexadecimal)	0006	20_04_24_AE_30_03	0000	---
		Analog data 1 + Top and valley shot + generic status	000B (hexadecimal)	0006	20_04_24_B8_30_03	0000	---
DRT2-DA02		Generic Status	0001 (hexadecimal)	0006	20_04_24_79_30_03	0000	---

Model		Name	Produced connection size	Produced connection path length	Produced connection path	Consumed connection path length	Consumed connection path
Basic Unit	Expansion Unit						
DRT2-TS04T DRT2-TS04P		Temperature Data 1 (Normal)	0008	0006	20_04_24_68_30_03	0000	---
		Temperature Data 1 (1/100 display)	0010	0006	20_04_24_6C_30_03	0000	---
		Temperature Data 2 (Normal)	0008	0006	20_04_24_72_30_03	0000	---
		Temperature Data 2 (1/100 display)	0010	0006	20_04_24_76_30_03	0000	---
		Generic Status	0001	0006	20_04_24_79_30_03	0000	---
		Top and Valley shot	0002	0006	20_04_24_7A_30_03	0000	---
		Analog Status	0004	0006	20_04_24_86_30_03	0000	---
		Temperature Data 1 + Temperature Data 2 (Normal)	0010	0006	20_04_24_90_30_03	0000	---
		Temperature Data 1 + Temperature Data 2 (1/100 display)	0020	0006	20_04_24_94_30_03	0000	---
		Top and Valley shot + Generic Status	0003	0006	20_04_24_97_30_03	0000	---
		Analog Status + Generic Status	0005	0006	20_04_24_A4_30_03	0000	---
		Temperature Data 1 (Normal) + Top and Valley shot	000A	0006	20_04_24_AE_30_03	0000	---
		Temperature Data 1 (1/100 display) + Top and Valley shot	0012	0006	20_04_24_B2_30_03	0000	---
		Temperature Data 1 (Normal) + Top and Valley shot + Generic Status	000B	0006	20_04_24_B8_30_03	0000	---
		Temperature Data 1 (1/100 display) + Top and Valley shot + Generic Status	0013	0006	20_04_24_BC_30_03	0000	---

# Appendix C

## Restrictions on Reading Total ON Time/Contact Operation Counter for All Slaves at Once

### Restrictions

The Monitor Status for Total ON Time or Contact Operation Monitor for All Slaves Read at Once command is not supported by the following models with manufacturer revision 1.01.

If the command is executed for a model with manufacturer revision 1.01, the values in the response area data may not be correct.

### Applicable Models

Slave name	Model
Remote I/O Terminal with 16 inputs	DRT2-ID16(-1)
Remote I/O Terminal with 16 outputs	DRT2-OD16(-1)
Environment-resistive Terminal with 8 inputs	DRT2-ID08C(-1)
Environment-resistive Terminal with 16 inputs	DRT2-HD16C(-1)
Environment-resistive Terminal with 8 outputs	DRT2-OD08C(-1)
Sensor Connector Terminal with 16 inputs	DRT2-ID16S(-1)

- Note**
- The (-1) suffix refers to models with PNP.
  - The read command cannot be used with DRT2-ID16(-1) and DRT2-OD16(-1), even if an Expansion Unit is mounted to the Remote I/O Terminal.
  - Models with manufacturer revision 1.02 or later (lot number 1263E or later) support the Monitor Status for Total ON Time or Contact Operation Monitor for All Slaves Read at Once command.  
Lot numbers:  
In the lot number 1263E, 12 = day, 6 = month, 3 = year, and E = factory where product was manufactured. Therefore, 1263E indicates a product manufactured on June 12, 2003.
  - DRT2 Slaves not mentioned in the above table support the Monitor Status for Total ON Time or Contact Operation Monitor for All Slaves Read at Once command, even if the Slaves are models with manufacturer revision 1.01.

### Checking the Manufacturer Revision Code

The manufacturer revision code can be checked by reading it using the EXPLICIT MESSAGE SEND command (2801) or from the Configurator.

#### EXPLICIT MESSAGE SEND Command (2801)

Explicit message	Service	Function	Command					Response
			Service Code	Class ID	Instance ID	Attribute ID	Data size	
Identity revision	Read	Reads the identity revision	0E	01	01	04	---	2 bytes E.g., Response data: 0102: manufacturer revision 1.02

### Reading from the Configurator

Select the uploaded Unit using the Configurator, click the right mouse button over the Unit, and select **Property**. The value displayed in the *Revision* field of the Property Window is the identity software version.

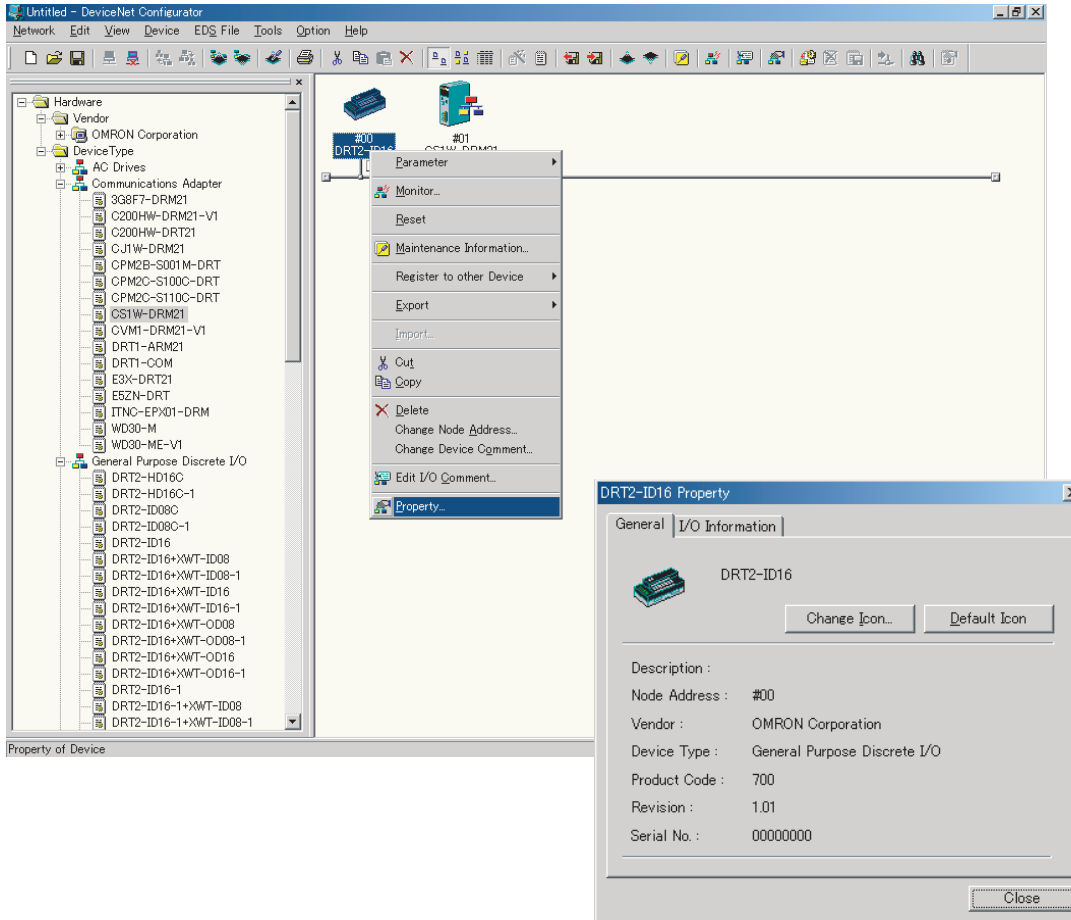

### Reading Monitor Status for Each Terminal

For models that do not support the Monitor Status for Total ON Time or Contact Operation Monitor for All Slaves Read at Once command, read the monitor status for Total ON Time or Contact Operation Monitor for each terminal separately.

#### Reading Each Terminal

Reading input terminals	Read using the Attribute ID 67 Hex, as described under <i>Setting and Monitoring the Terminal (Input)</i> on page 471.
Reading output terminals	Read using the Attribute ID 67 Hex, as described under <i>Setting and Monitoring the Terminal (Output)</i> on page 472.

### Converting Data Read for Each Terminal into Data for All Slaves

The data read for each individual terminal can be processed automatically using a ladder program as a batch of data for all Slaves. Use the following method to read the data for all Slaves when using a product with manufacturer revision 1.01. The method shown here reads the data separately for each terminal and then converts the data into data read as a batch for all Slaves.

## Ladder Program System Configuration

PLC: Master  
 Node: Number 30  
 Slave: Node number 00

**Note** The ladder program reads data for one Slave at a time.

## Operation Specifications

The following table shows the applicable models (with manufacturer revision 1.01).

Slave name	Model
Remote I/O Terminal with 16 inputs	DRT2-ID16(-1)
Remote I/O Terminal with 16 outputs	DRT2-OD16(-1)
Environment-resistive Terminal with 8 inputs	DRT2-ID08C(-1)
Environment-resistive Terminal with 16 inputs	DRT2-HD16C(-1)
Environment-resistive Terminal with 8 outputs	DRT2-OD08C(-1)
Sensor Connector Terminal with 16 inputs	DRT2-ID16S(-1)

- Note**
- The (-1) suffix refers to models with PNP.
  - The read command cannot be used with DRT2-ID16(-1) and DRT2-OD16(-1), even if an Expansion Unit is mounted to the Remote I/O Terminal.
  - DRT2 Slaves not mentioned in the above table support the Monitor Status for Total ON Time or Contact Operation Monitor for All Slaves Read at Once command, even if the Slaves are models with manufacturer revision 1.01. Therefore, the ladder program shown here is not required.

## Ladder Program Specifications

- When the start bit 0.00 turns ON, data starts being read for each individual terminal automatically, and the response is then transferred altogether as batch read data to DM 00050 to DM 00055.
- When one portion of the processing is completed, the end bit 0.02 turns ON.
- If the command needs to be executed again, after the end bit 0.02 turns ON, turn OFF 0.00 again, and then execute the program.

- Note**
- The model is automatically recognized by the ladder program, so the ladder program does not need to be changed to suit each model.
  - In the following programming examples, the Master is node number 30 and the Slave is node number 00.
  - To change the node numbers, edit the program as follows:

### Changing the Master's Node Number

Change the upper byte of the constant part of the MOV21 #1FFE DM 00003 command in the ladder program.  
 Example: Change to #3FFE for a Master with node number 63.

### Changing the Slave's Node Number

Change the upper byte of the constant part of the MOV21 #000E DM 00011 command in the ladder program.  
 Example: Change to #0F0E for a Slave with node number 15.

## Response Area

Use words DM 00050 to DM 00055 to store the data. The internal processing areas are also reserved, so refer to the list of used areas.

**Response Storage Specifications**

The format is the same as for standard explicit message responses

Area	High side	Low side	Remarks
DM 0050	End code	End code	0000: Ended normally. OCFF: Error occurred.
DM 0051	08	00	0800 fixed
DM 0052	Monitors status of input No. 0 to No. 7.	Monitors status of input No. 8 to No. 15.	
DM 0053	Monitors status of input No. 16 to No. 23.	Monitors status of input No. 31 to No. 24.	
DM 0054	Monitors status of output No. 0 to No. 7.	Monitors status of output No. 8 to No. 15.	
DM 0055	Monitors status of output No. 16 to No. 23.	Monitors status of output No. 31 to No. 24.	

**List of Used Areas**

I/O Area	Words 0 and 1
DM Area	DM 00000 to DM 00007, DM 00010 to DM 00014, DM 00020 to DM 00026, DM 00050 to DM 00055 DM 00101 to DM 00104, DM 00120 to DM 00123, DM 00200 to DM 00204 + (10 x n) n: Unit's number of input points Example: If n = 32 points, the area is DM 00200 to DM 00524 DM 00600 to DM 00604 + (10 x m) m: Unit's number of output points Example: If m = 16, the area is DM 00600 to DM 00764
Timer	1, 2

## Ladder Programming Sample

### Processing to Set the Initial Data

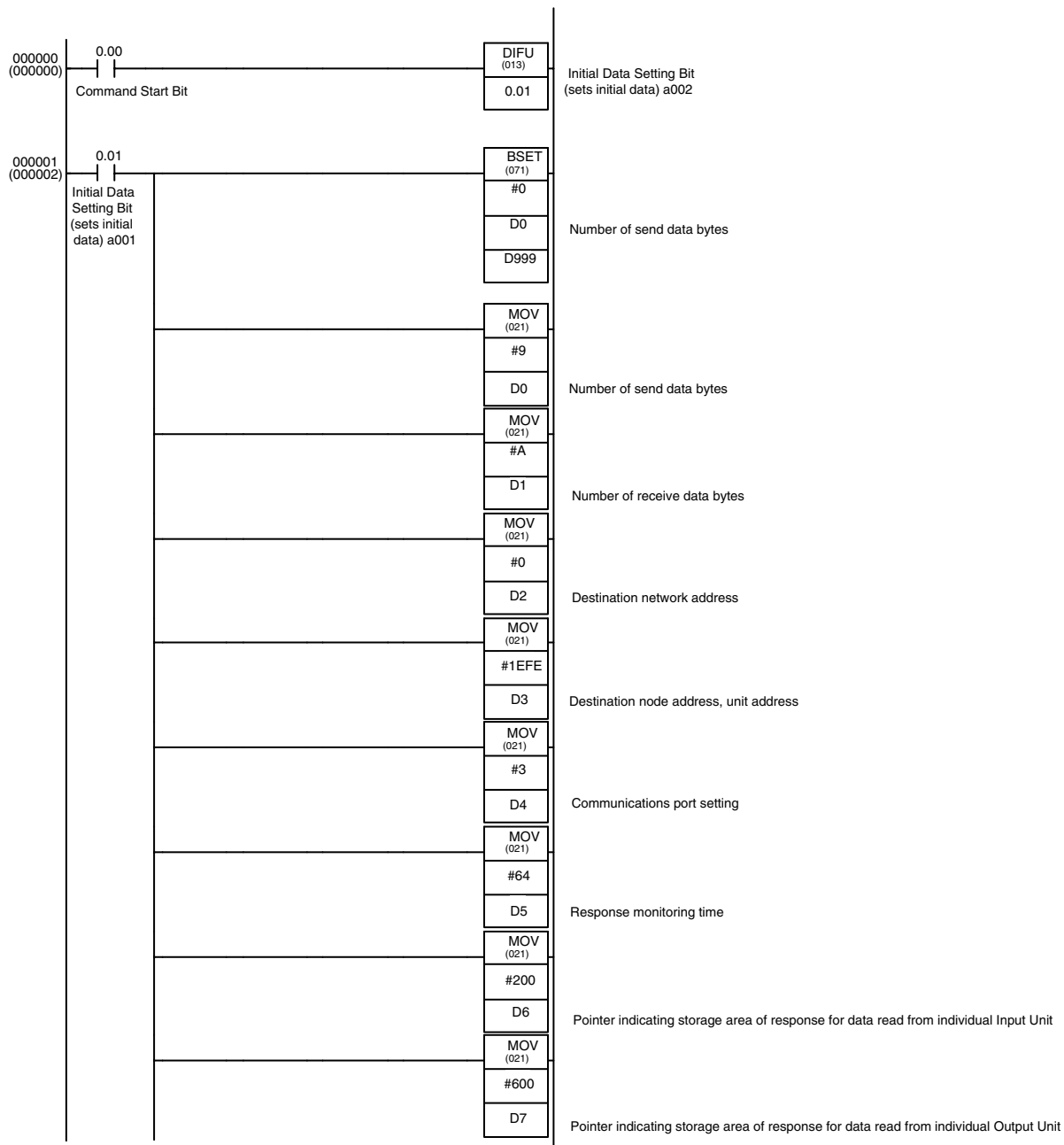



	MOV (021)	Explicit command code
	#201	
	D10	
	MOV (021)	Slave address, Service Code
	#E	
	D11	
	MOV (021)	Class ID
	#8	
	D12	
	MOV (021)	Instance ID
	#1	
	D13	
	MOV (021)	Attribute ID
	#6700	
	D14	
	MOV (021)	Bit designator
	#8	
	D20	
	MOV (021)	Pointer for input bits 00 to 15 of individually read data
	#204	
	D21	
	MOV (021)	Pointer for input bits 16 to 31 of individually read data
	#364	
	D22	
	MOV (021)	Pointer for output bits 00 to 15 of individually read data
	#604	
	D23	
	MOV (021)	Pointer for output bits 16 to 31 of individually read data
	#764	
	D24	
	MOV (021)	Pointer for end code of response for individually read input
	#201	
	D25	
	MOV (021)	Pointer for end code of response for individually read output
	#601	
	D26	
	MOV (021)	Final data input bits 00 to 15
	#800	
	D51	
	MOV (021)	Processing control words
	#1	
	1	

### Processing to Read Individual Input Units

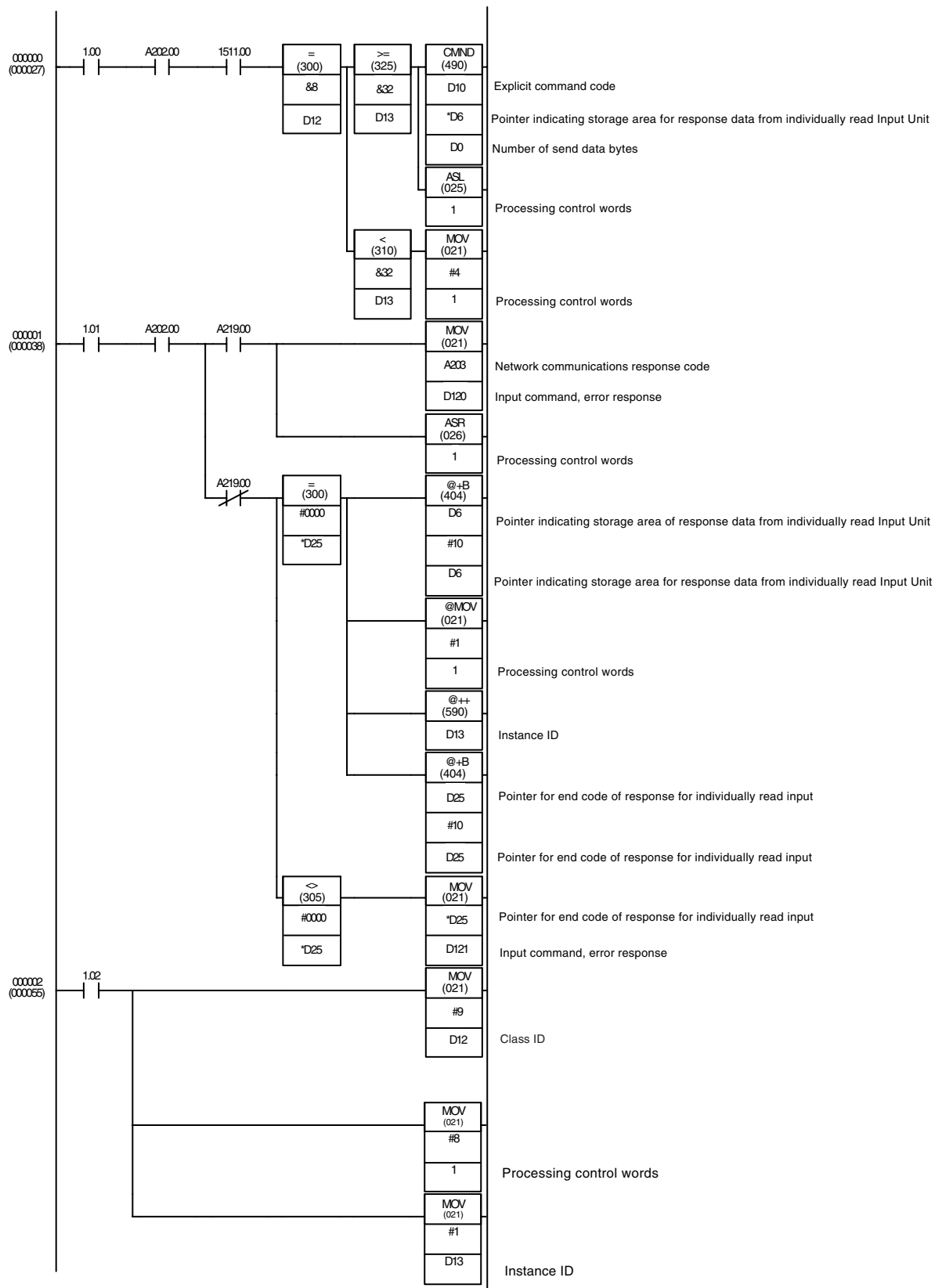

**Processing to Read Individual Output Units**

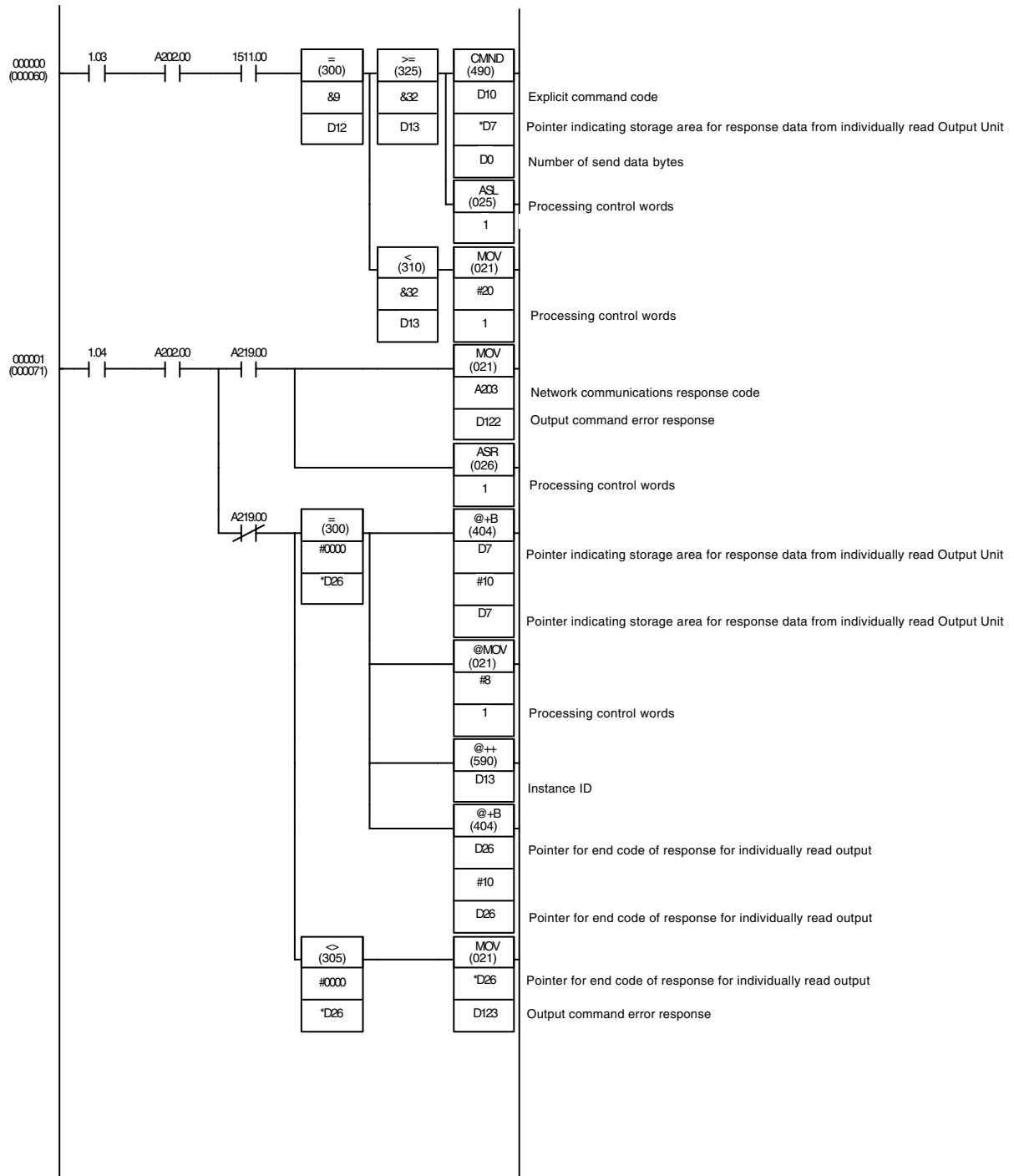

**Error Response Processing**

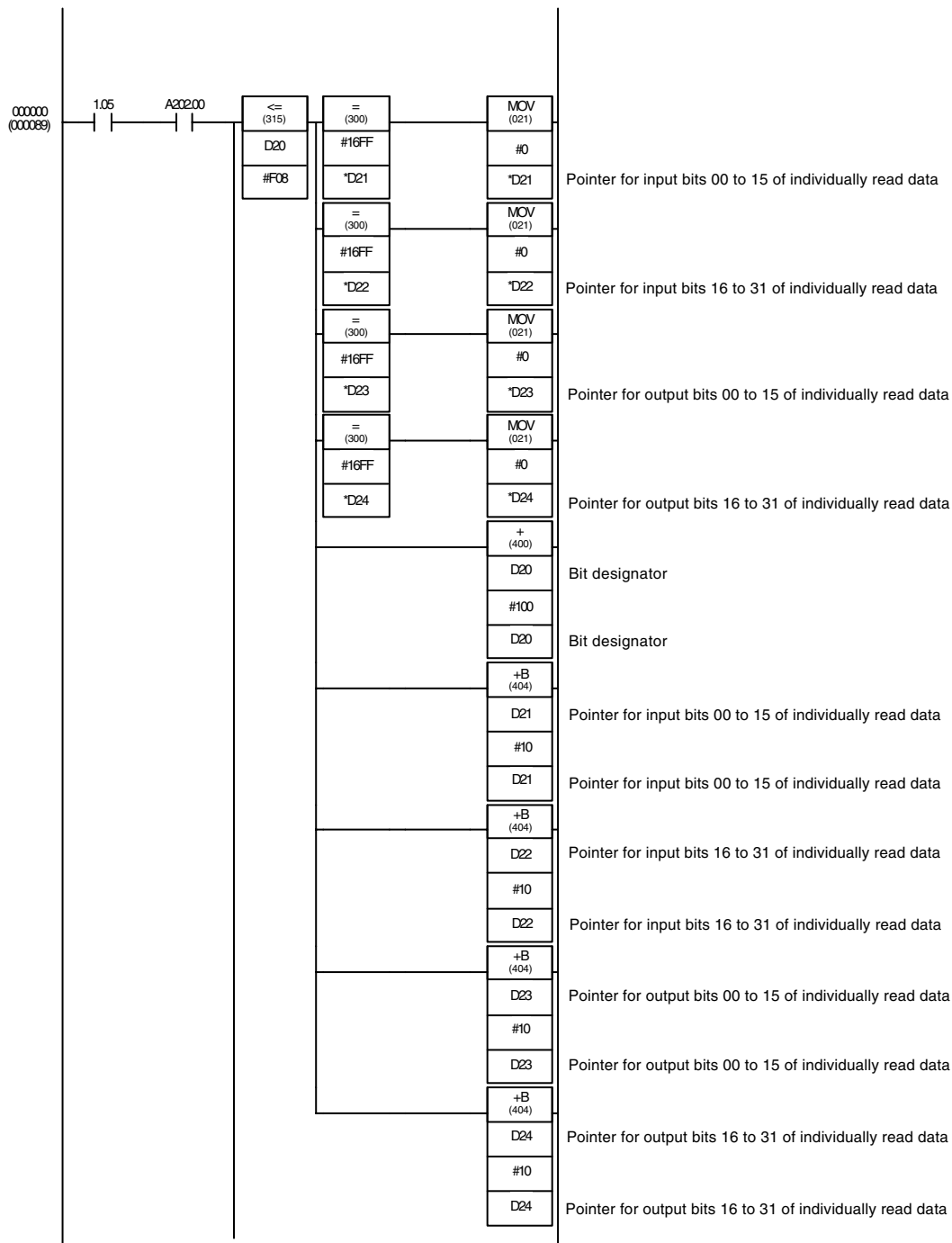

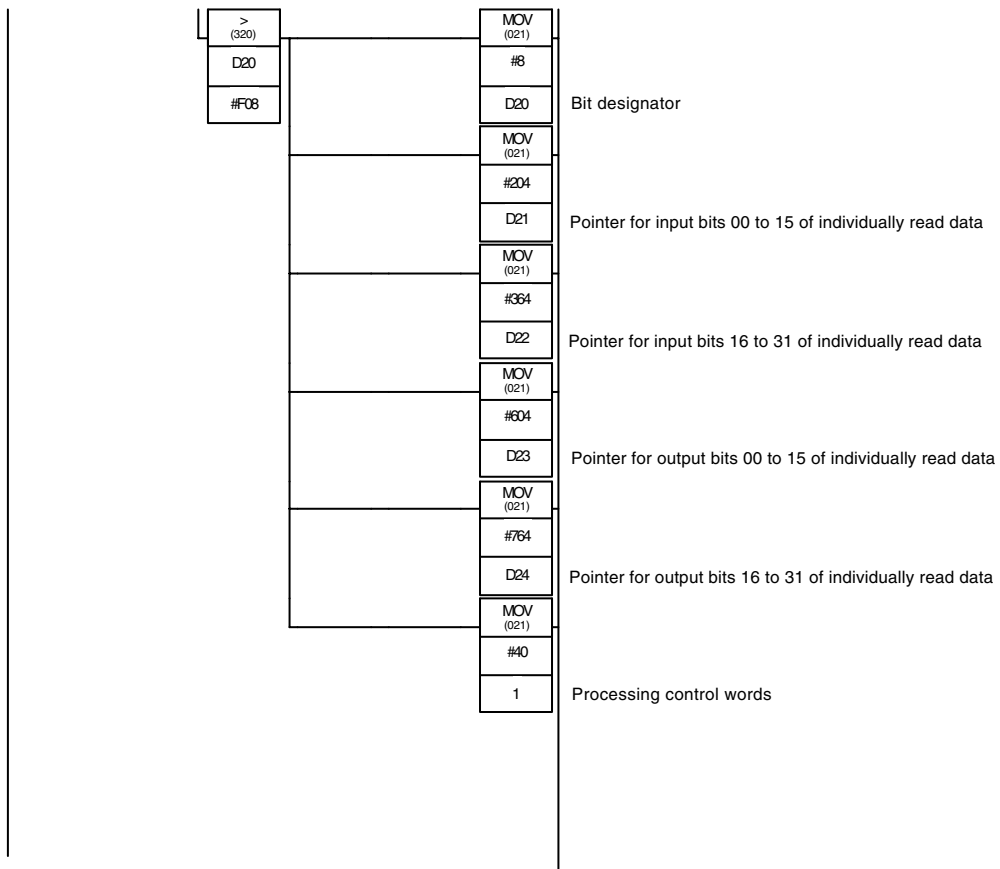

**Processing to Combine Data**

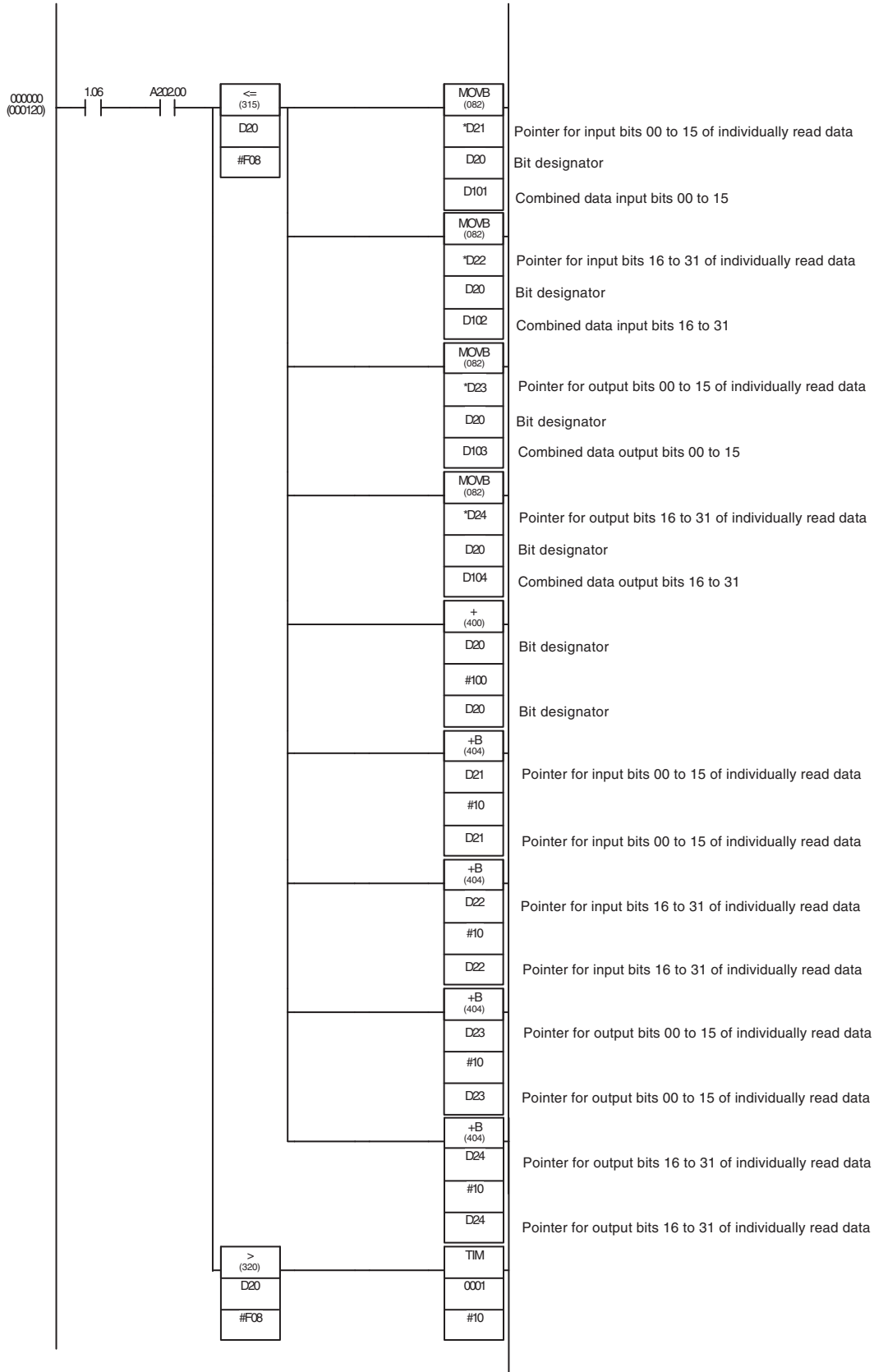

### Processing to Create Final Data

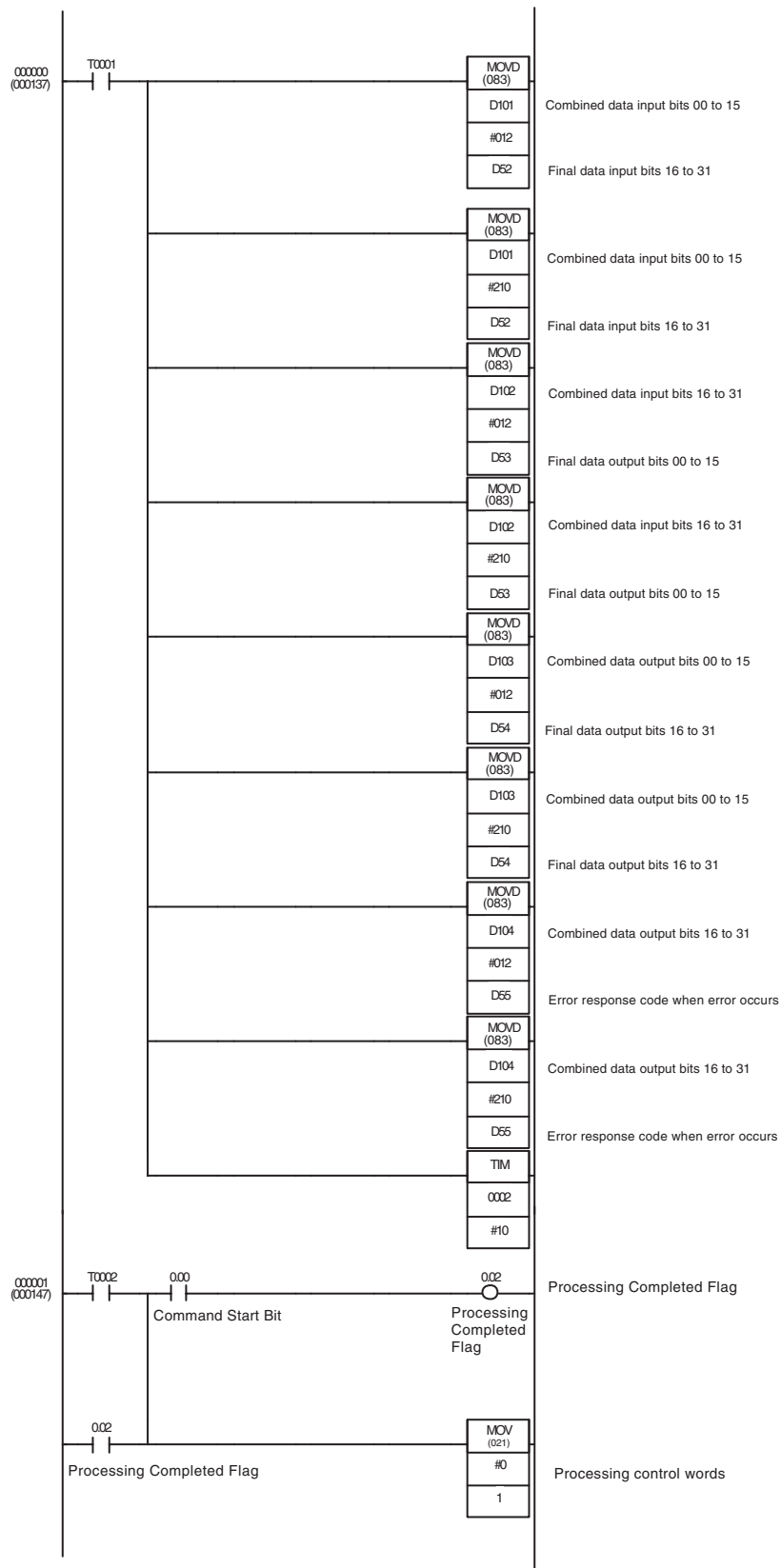

**Error Response Storage Processing when Command Ends Abnormally**

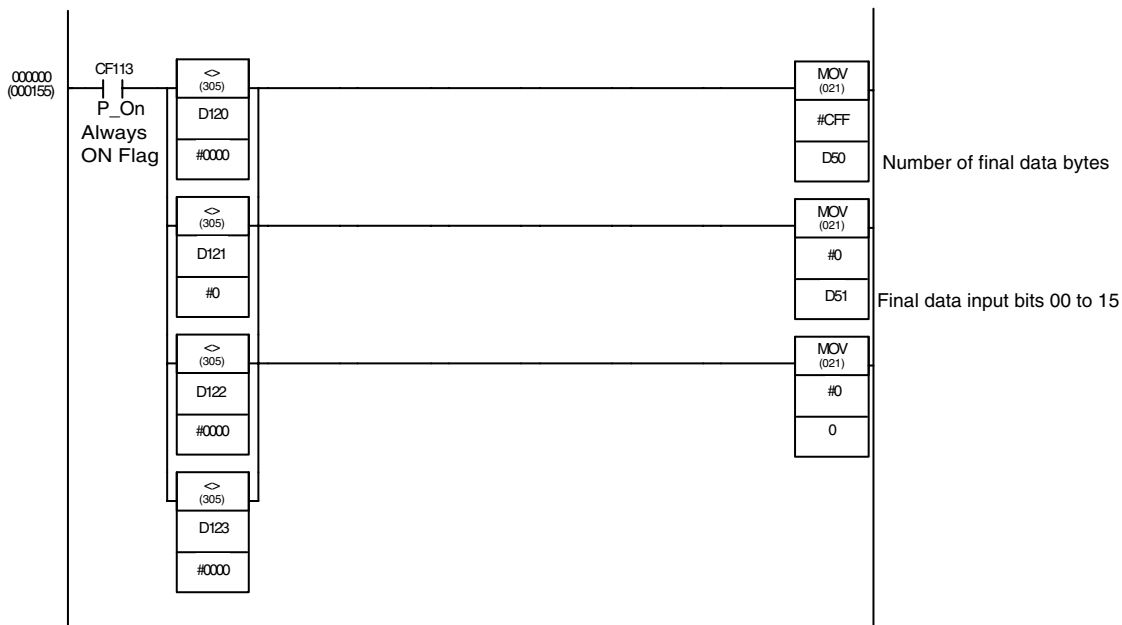

**END**







# Appendix D

## Connectable Devices

### General-purpose Slaves

Model	Specifications	Manufacturer
DRT2-ID08	Remote I/O Terminal with 8 transistor inputs (NPN)	OMRON
DRT2-ID08-1	Remote I/O Terminal with 8 transistor inputs (PNP)	OMRON
DRT2-ID16	Remote I/O Terminal with 16 transistor inputs (NPN)	OMRON
DRT2-ID16-1	Remote I/O Terminal with 16 transistor inputs (PNP)	OMRON
DRT2-OD08	Remote I/O Terminal with 8 transistor outputs (NPN)	OMRON
DRT2-OD08-1	Remote I/O Terminal with 8 transistor outputs (PNP)	OMRON
DRT2-OD16	Remote I/O Terminal with 16 transistor outputs (NPN)	OMRON
DRT2-OD16-1	Remote I/O Terminal with 16 transistor outputs (PNP)	OMRON
DRT2-MD16	Remote I/O Terminal with 8 transistor inputs and 8 transistor outputs (NPN)	OMRON
DRT2-MD16-1	Remote I/O Terminal with 8 transistor inputs and 8 transistor outputs (PNP)	OMRON
DRT2-ROS16	Remote I/O Terminal with 16 relay outputs	OMRON
XWT-ID16	Remote I/O Terminal Expansion Unit with 16 transistor inputs (NPN)	OMRON
XWT-ID16-1	Remote I/O Terminal Expansion Unit with 16 transistor inputs (PNP)	OMRON
XWT-OD16	Remote I/O Terminal Expansion Unit with 16 transistor outputs (NPN)	OMRON
XWT-OD16-1	Remote I/O Terminal Expansion Unit with 16 transistor outputs (PNP)	OMRON
XWT-ID08	Remote I/O Terminal Expansion Unit with 8 transistor inputs (NPN)	OMRON
XWT-ID08-1	Remote I/O Terminal Expansion Unit with 8 transistor inputs (PNP)	OMRON
XWT-OD08	Remote I/O Terminal Expansion Unit with 8 transistor outputs (NPN)	OMRON
XWT-OD08-1	Remote I/O Terminal Expansion Unit with 8 transistor outputs (PNP)	OMRON
DRT2-ID16TA	Remote I/O Terminal with 3-tier terminal blocks and 16 transistor inputs (NPN)	OMRON
DRT2-ID16TA-1	Remote I/O Terminal with 3-tier terminal blocks and 16 transistor inputs (PNP)	OMRON
DRT2-OD16TA	Remote I/O Terminal with 3-tier terminal blocks and 16 transistor outputs (NPN)	OMRON
DRT2-OD16TA-1	Remote I/O Terminal with 3-tier terminal blocks and 16 transistor outputs (PNP)	OMRON
DRT2-MD16TA	Remote I/O Terminal with 3-tier terminal blocks and 8 transistor inputs/8 transistor outputs (NPN)	OMRON
DRT2-MD16TA-1	Remote I/O Terminal with 3-tier terminal blocks and 8 transistor inputs/8 transistor outputs (PNP)	OMRON
DRT2-ID16S	Sensor Connector Terminal with 16 transistor inputs (NPN)	OMRON
DRT2-ID16S-1	Sensor Connector Terminal with 16 transistor inputs (PNP)	OMRON
DRT2-MD16S	Sensor Connector Terminal with 8 transistor inputs and 8 transistor outputs (NPN)	OMRON
DRT2-MD16S-1	Sensor Connector Terminal with 8 transistor inputs and 8 transistor outputs (PNP)	OMRON
DRT2-ID16SL	Screw-less Clamp Remote I/O Terminal with 16 transistor inputs (NPN) and no detection functions	OMRON
DRT2-ID16SL-1	Screw-less Clamp Remote I/O Terminal with 16 transistor inputs (PNP) and no detection functions	OMRON
DRT2-OD16SL	Screw-less Clamp Remote I/O Terminal with 16 transistor outputs (NPN) and no detection functions	OMRON
DRT2-OD16SL-1	Screw-less Clamp Remote I/O Terminal with 16 transistor outputs (PNP) and no detection functions	OMRON
DRT2-ID16SLH	Screw-less Clamp Remote I/O Terminal with 16 transistor inputs (NPN) and detection functions	OMRON
DRT2-ID16SLH-1	Screw-less Clamp Remote I/O Terminal with 16 transistor inputs (PNP) and detection functions	OMRON

Model	Specifications	Manufacturer
DRT2-OD16SLH	Screw-less Clamp Remote I/O Terminal with 16 transistor outputs (NPN) and detection functions	OMRON
DRT2-OD16SLH-1	Screw-less Clamp Remote I/O Terminal with 16 transistor outputs (PNP) and detection functions	OMRON
DRT2-ID16ML	MIL Connector Terminal with 16 transistor inputs (NPN)	OMRON
DRT2-ID16ML-1	MIL Connector Terminal with 16 transistor inputs (PNP)	OMRON
DRT2-ID16MLX	MIL Connector Terminal with 16 transistor inputs (NPN) (Includes cable with attached connector.)	OMRON
DRT2-ID16MLX-1	MIL Connector Terminal with 16 transistor inputs (PNP) (Includes cable with attached connector.)	OMRON
DRT2-ID32ML	MIL Connector Terminal with 32 transistor inputs (NPN)	OMRON
DRT2-ID32ML-1	MIL Connector Terminal with 32 transistor inputs (PNP)	OMRON
DRT2-OD16ML	MIL Connector Terminal with 16 transistor outputs (NPN)	OMRON
DRT2-OD16ML-1	MIL Connector Terminal with 16 transistor outputs (PNP)	OMRON
DRT2-OD16MLX	MIL Connector Terminal with 16 transistor outputs (NPN) (Includes cable with attached connector.)	OMRON
DRT2-OD16MLX-1	MIL Connector Terminal with 16 transistor outputs (PNP) (Includes cable with attached connector.)	OMRON
DRT2-OD32ML	MIL Connector Terminal with 32 transistor outputs (NPN)	OMRON
DRT2-OD32ML-1	MIL Connector Terminal with 32 transistor outputs (PNP)	OMRON
DRT2-MD32ML	MIL Connector Terminal with 16 transistor inputs/16 transistor outputs (NPN)	OMRON
DRT2-MD32ML-1	MIL Connector Terminal with 16 transistor inputs/16 transistor outputs (PNP)	OMRON
DRT2-ID32B	Board MIL Connector Terminal with connector parallel to board and with 32 transistor inputs (NPN)	OMRON
DRT2-ID32B-1	Board MIL Connector Terminal with connector parallel to board and with 32 transistor inputs (PNP)	OMRON
DRT2-OD32B	Board MIL Connector Terminal with connector parallel to board and with 32 transistor outputs (NPN)	OMRON
DRT2-OD32B-1	Board MIL Connector Terminal with connector parallel to board and with 32 transistor outputs (PNP)	OMRON
DRT2-MD32B	Board MIL Connector Terminal with connector parallel to board and with 16 transistor inputs/16 transistor outputs (NPN)	OMRON
DRT2-MD32B-1	Board MIL Connector Terminal with connector parallel to board and with 16 transistor inputs/16 transistor outputs (PNP)	OMRON
DRT2-ID32BV	Board MIL Connector Terminal with connector perpendicular to board and with 32 transistor inputs (NPN)	OMRON
DRT2-ID32BV-1	Board MIL Connector Terminal with connector perpendicular to board and with 32 transistor inputs (PNP)	OMRON
DRT2-OD32BV	Board MIL Connector Terminal with connector perpendicular to board and with 32 transistor outputs (NPN)	OMRON
DRT2-OD32BV-1	Board MIL Connector Terminal with connector perpendicular to board and with 32 transistor outputs (PNP)	OMRON
DRT2-MD32BV	Board MIL Connector Terminal with connector perpendicular to board and with 16 transistor inputs/16 transistor outputs (NPN)	OMRON
DRT2-MD32BV-1	Board MIL Connector Terminal with connector perpendicular to board and with 16 transistor inputs/16 transistor outputs (PNP)	OMRON
DRT2-ID32SL	Screw-less Clamp Terminal with 32 transistor inputs and no detection functions (NPN)	OMRON
DRT2-ID32SL-1	Screw-less Clamp Terminal with 32 transistor inputs and no detection functions (PNP)	OMRON
DRT2-OD32SL	Screw-less Clamp Terminal with 32 transistor outputs and no detection functions (NPN)	OMRON
DRT2-OD32SL-1	Screw-less Clamp Terminal with 32 transistor outputs and no detection functions (PNP)	OMRON

Model	Specifications	Manufacturer
DRT2-MD32SL	Screw-less Clamp Terminal with 16 transistor inputs, 16 transistor outputs, and no detection functions (NPN)	OMRON
DRT2-MD32SL-1	Screw-less Clamp Terminal with 16 transistor inputs, 16 transistor outputs, and no detection functions (PNP)	OMRON
DRT2-ID32SLH	Screw-less Clamp Terminal with 32 transistor inputs and detection functions (NPN)	OMRON
DRT2-ID32SLH-1	Screw-less Clamp Terminal with 32 transistor inputs and detection functions (PNP)	OMRON
DRT2-OD32SLH	Screw-less Clamp Terminal with 32 transistor outputs and detection functions (NPN)	OMRON
DRT2-OD32SLH-1	Screw-less Clamp Terminal with 32 transistor outputs and detection functions (PNP)	OMRON
DRT2-MD32SLH	Screw-less Clamp Terminal with 16 transistor inputs, 16 transistor outputs, and detection functions (NPN)	OMRON
DRT2-MD32SLH-1	Screw-less Clamp Terminal with 16 transistor inputs, 16 transistor outputs, and detection functions (PNP)	OMRON

## Environment-resistive Slaves

Model	Specifications	Manufacturer
DRT2-ID08C	Advanced Environment-resistive Terminal with 8 transistor inputs (NPN) Conforms to IEC IP67	OMRON
DRT2-ID08C-1	Advanced Environment-resistive Terminal with 8 transistor inputs (PNP) Conforms to IEC IP67	OMRON
DRT2-HD16C	Advanced Environment-resistive Terminal with 16 transistor inputs (NPN) Conforms to IEC IP67	OMRON
DRT2-HD16C-1	Advanced Environment-resistive Terminal with 16 transistor inputs (PNP) Conforms to IEC IP67	OMRON
DRT2-OD08C	Advanced Environment-resistive Terminal with 8 transistor outputs (NPN) Conforms to IEC IP67	OMRON
DRT2-OD08C-1	Advanced Environment-resistive Terminal with 8 transistor outputs (PNP) Conforms to IEC IP67	OMRON
DRT2-ID04CL	Standard Environment-resistive Terminal with 4 transistor inputs (NPN) Conforms to IEC IP67	OMRON
DRT2-ID04CL-1	Standard Environment-resistive Terminal with 4 transistor inputs (PNP) Conforms to IEC IP67	OMRON
DRT2-ID08CL	Standard Environment-resistive Terminal with 8 transistor inputs (NPN) Conforms to IEC IP67	OMRON
DRT2-ID08CL-1	Standard Environment-resistive Terminal with 8 transistor inputs (PNP) Conforms to IEC IP67	OMRON
DRT2-HD16CL	Standard Environment-resistive Terminal with 16 transistor inputs (NPN) Conforms to IEC IP67	OMRON
DRT2-HD16CL-1	Standard Environment-resistive Terminal with 16 transistor inputs (PNP) Conforms to IEC IP67	OMRON
DRT2-OD04CL	Standard Environment-resistive Terminal with 4 transistor outputs (NPN) Conforms to IEC IP67	OMRON
DRT2-OD04CL-1	Standard Environment-resistive Terminal with 4 transistor outputs (PNP) Conforms to IEC IP67	OMRON
DRT2-OD08CL	Standard Environment-resistive Terminal with 8 transistor outputs (NPN) Conforms to IEC IP67	OMRON
DRT2-OD08CL-1	Standard Environment-resistive Terminal with 8 transistor outputs (PNP) Conforms to IEC IP67	OMRON
DRT2-WD16CL	Standard Environment-resistive Terminal with 16 transistor outputs (NPN) Conforms to IEC IP67	OMRON

Model	Specifications	Manufacturer
DRT2-WD16CL-1	Standard Environment-resistive Terminal with 16 transistor outputs (PNP) Conforms to IEC IP67	OMRON
DRT2-MD16CL	Standard Environment-resistive Terminal with 16 transistor inputs /6 transistor outputs (NPN) Conforms to IEC IP67	OMRON
DRT2-MD16CL-1	Standard Environment-resistive Terminal with 16 transistor inputs /6 transistor outputs (PNP) Conforms to IEC IP67	OMRON

## Analog Slaves

Model	Specifications	Manufacturer
DRT2-AD04	Analog Input Terminal with 4 analog data inputs (4 words)	OMRON
DRT2-AD04H	High-resolution Analog Input Terminal with 4 analog data inputs (4 words)	OMRON
DRT2-DA02	Analog Output Terminal with 2 analog data inputs (2 words)	OMRON
DRT2-TS04T	Thermocouple Temperature Input Terminal with 4 temperature data inputs	OMRON
DRT2-TS04P	Platinum-resistance Thermometer Temperature Input Terminal with 4 temperature data inputs	OMRON

## Communications Cables

Model	Specifications	Manufacturer
DCA2-5C10	Thick Cable: 5 wires, 100 m	OMRON
DCA1-5C10	Thin Cable: 5 wires, 100 m	OMRON
DVN18-10G	Thick Cable: 5 wires, 10 m	Nihon Wire & Cable (See note 1.)
DVN18-30G	Thick Cable: 5 wires, 30 m	Nihon Wire & Cable (See note 1.)
DVN18-50G	Thick Cable: 5 wires, 50 m	Nihon Wire & Cable (See note 1.)
DVN18-100G	Thick Cable: 5 wires, 100 m	Nihon Wire & Cable (See note 1.)
DVN18-300G	Thick Cable: 5 wires, 300 m	Nihon Wire & Cable (See note 1.)
DVN18-500G	Thick Cable: 5 wires, 500 m	Nihon Wire & Cable (See note 1.)
DVN24-10G	Thin Cable: 5 wires, 10 m	Nihon Wire & Cable (See note 1.)
DVN24-30G	Thin Cable: 5 wires, 30 m	Nihon Wire & Cable (See note 1.)
DVN24-50G	Thin Cable: 5 wires, 50 m	Nihon Wire & Cable (See note 1.)
DVN24-100G	Thin Cable: 5 wires, 100 m	Nihon Wire & Cable (See note 1.)
DVN24-300G	Thin Cable: 5 wires, 300 m	Nihon Wire & Cable (See note 1.)
DVN24-500G	Thin Cable: 5 wires, 500 m	Nihon Wire & Cable (See note 1.)
1485C-P1-A50	Thick Cable: 5 wires, 50 m	Allen-Bradley (See note 2.)
1485C-P1-C150	Thin Cable: 5 wires, 150 m	Allen-Bradley (See note 2.)
DCA1-5CN□□W1	Cable with shielded micro-size (M12) connectors on both ends (female socket and male plug)	OMRON

Model	Specifications	Manufacturer
DCA1-5CN□□F1	Cable with shielded micro-size (M12) connector (female socket) on one end	OMRON
DCA1-5CN□□H1	Cable with shielded micro-size (M12) connector (male plug) on one end	OMRON
DCA1-5CN□□W5	Cable with shielded connector on both ends (male plug on mini-size end, female socket on micro-size end)	OMRON
DCA2-5CN□□W1	Cable with shielded mini-size connectors on both ends (female socket and male plug)	OMRON
DCA2-5CN□□F1	Cable with shielded mini-size connector on one end (female socket)	OMRON
DCA1-5CN□□H1	Cable with shielded mini-size connector on one end (male plug)	OMRON

- Note**
1. The cables made by Nihon Wire & Cable Company Ltd. Are sold through the OMRON 24 Service Co., Ltd. The product specifications are identical to the OMRON cable specifications.
  2. The cables made by Allen-Bradley are stiffer than the cables made by OMRON and Nihon Wire & Cable Company Ltd., so do not bend the Allen-Bradley cables as much as the others.

## Connectors

Model	Specifications	Manufacturer
XW4G-05C1-H1-D	For node connection Includes connector set screws	OMRON
XW4G-05C4-TF-D	For node connection (multi-drop wiring) Includes connector set screws	OMRON
XW4B-05C4-TF-D	For node connection (multi-drop wiring) Includes connector set screws	OMRON

## Connectors (Industry Standard Sensor Connectors)

### Tyco Electronics Amp

Model	Housing color	Applicable wire range	
3-1473562-4	Orange	Sheath outer diameter: 0.6 to 0.9 mm	Cross-sectional area: 0.08 to 0.5 mm <sup>2</sup>
1-1473562-4	Red	Sheath outer diameter: 0.9 to 1.0 mm	
1473562-4	Yellow	Sheath outer diameter: 1.0 to 1.15 mm	
2-1473562-4	Blue	Sheath outer diameter: 1.15 to 1.35 mm	
4-1473562-4	Green	Sheath outer diameter: 1.35 to 1.6 mm	

### Sumitomo 3M

Model	Housing color	Applicable wire range
37104-3101-000FL	Red	AWG26 (0.14 mm <sup>2</sup> ) to AWG24 (0.2 mm <sup>2</sup> ), sheath outer diameter: 0.8 to 1.0 mm
37104-3122-000FL	Yellow	AWG26 (0.14 mm <sup>2</sup> ) to AWG24 (0.2 mm <sup>2</sup> ), sheath outer diameter: 1.0 to 1.2 mm
37104-3163-000FL	Orange	AWG26 (0.14 mm <sup>2</sup> ) to AWG24 (0.2 mm <sup>2</sup> ), sheath outer diameter: 1.2 to 1.6 mm
37104-3124-000FL	Green	AWG22 (0.3 mm <sup>2</sup> ) to AWG20 (0.5 mm <sup>2</sup> ), sheath outer diameter: 1.0 to 1.2 mm
37104-3165-000FL	Blue	AWG22 (0.3 mm <sup>2</sup> ) to AWG20 (0.5 mm <sup>2</sup> ), sheath outer diameter: 1.2 to 1.6 mm
37104-3106-000FL	Gray	AWG22 (0.3 mm <sup>2</sup> ) to AWG20 (0.5 mm <sup>2</sup> ), sheath outer diameter: 1.6 to 2.0 mm

### OMRON

Model	Specifications	Applicable wire range
XN2A-1430	Spring clamp type	AWG28 (0.08 mm <sup>2</sup> ) to AWG20 (0.5 mm <sup>2</sup> ), sheath outer diameter: 1.5 mm max.

## Crimp Terminals for Communications Cables

### PHOENIX CONTACT: A/AI Series

Cable type		Connector type			Dedicated tool
		XW4B-05C1-H1-D XW4B-05C1-V1R-D MSTB2.5/5-ST-5.08AU	XW4B-05C4-TF-D XS4B-05C4-T-D	XW4G-05C1-H1-D XW4G-05C4-TF-D	
For Thin Cable	Signal line	AI 0.25-6BU	AI 0.25-8YE	AI 0.25-8YE	CRIMPFOX ZA3
	Power line	AI 0.5-6WH	AI 0.5-10WH	AI 0.5-10WH	
For Thick Cable	Signal line	A1-6	A1-10	A1-10	
	Power line	AI 2.5-8BU	AI 2.5-10BU	AI 2.5-10BU	

## Screwdrivers for Connectors

Model	Specifications	Manufacturer (Supplier)
XW4Z-00C	Special screwdriver for DeviceNet connectors	OMRON
SZF-1	Special screwdriver for DeviceNet connectors	OMRON 24 Service Co., Ltd.

## Terminating Resistors

Model	Specifications	Manufacturer
DRS1-T	Terminal-block Terminating Resistor, 121 $\Omega$	OMRON
DRS2-1	Shielded Terminating Resistor (male plug), micro-size	
DRS2-2	Shielded Terminating Resistor (female socket), micro-size	
DRS3-1	Shielded Terminating Resistor (male plug), mini-size	

**Note** A Terminating Resistor can also be connected to a T-branch Tap.

## T-branch Taps

Model	Specifications	Manufacturer
DCN1-1C	Includes 3 connectors (When used on a trunk line, 1 branch line can be connected.) A Terminating Resistor can be connected.	OMRON
DCN1-3C	Includes 5 connectors (When used on a trunk line, 3 branch lines can be connected.) A Terminating Resistor can be connected.	OMRON

## T-branch Connectors

Model	Specifications	Manufacturer
DCN2-1	Shielded T-branch Connector (for 1 branch line)	OMRON

## Power Supply Sharing Taps

Model	Specifications	Manufacturer
1485T-P2T5-T5	Required when connecting more than one power supply. Reverse current prevention, ground terminal provided.	Allen-Bradley
DCN1-1P	One-branch tap for power supply. Use this tap when connecting a communications power supply. Two connectors and two fuses are standard.	OMRON

**Note** The Power Supply Sharing Taps are sold through the OMRON 24 Service Co., Ltd.

## Connectors for I/O Power Cables to Environment-resistive Slave Output Terminals

### DRT2-OD08C(-1)

Model	Specifications	Manufacturer
XS4W-D421-1□□-A	Cable with connectors on both ends (socket and plug)	OMRON
XS4F-D421-1□□-A	Cable with connector on one end (female socket)	
XS4H-D421-1□□-A	Cable with connector on one end (male plug)	

Always use DeviceNet Communications Connectors that conform to DeviceNet Connector standards.

### T-joints

Model	Specifications	Manufacturer
XS4R-D424-5	Shielded T-joint Use to branch an I/O power supply cable for an Environment-resistive Slave.	OMRON

### Y-joint Plugs and Sockets

Model	Specifications	Manufacturer
XS2R-D426-□11-F	With cable	OMRON
XS2R-D426-1	Without cable	

Use for Environment-resistive Slaves with 16 inputs or 16 outputs. (Branches a single connector's signals into two connectors.)

### Connector Covers for Environment-resistive Slaves

Model	Specifications	Manufacturer
XS2Z-12	Waterproof Cover (meets IP67 standards)	OMRON
XS2Z-15	Dust Cover	

### MIL Cables for Connector Terminals

#### Cables with Connectors on Both Ends (40-pin × 1 and 20-pin × 2)

Model	Applicable Slave	Applicable Relay Terminal	Manufacturer
G79-I□C	DRT2-ID16ML	G7TC-ID16/IA16	OMRON
	DRT2-OD16ML-1	G7TC-OC16-1	
G79-O□C	DRT2-OD16ML	G7TC-OC16/OC08	
		G70D-SOC16/VSOC16	
		G70DFOM16/VFOM16	
		G70A-ZOC16-3	
DRT2-OD16ML-1	DRT2-OD16ML-1	G70D-SOC08	
		G70R-SOC08	
		G70D-SOC16-1	
		G70D-FOM16-1	
		G70A-ZOC16-4	



Model	Applicable Slave	Applicable Relay Terminal	Manufacturer
G79-I50-25-D1 (50 cm) G79-I75-50-D1 (75 cm)	DRT2-ID32ML DRT2-ID32B	G7TC-ID16/IA16	OMRON
	DRT2-OD32ML-1 DRT2-OD32B-1	G7TC-OC16-1	
G79-O50-25-D1 (50 cm) G79-O75-50-D1 (75 cm)	DRT2-OD32ML DRT2-OD32B	G7TC-OC16/OC08 G70D-SOC16/VSOC16 G70D-FOM16/VFOM16 G70A-ZOC16-3 G70D-SOC08 G70R-ZOC08	
	DRT2-OD32ML-1 DRT2-OD32B-1	G70D-SOC16-1 G70D-FOM16-1 G70A-ZOC16-4	
G79-M50-25-D1 (50 cm) G79-M75-50-D1 (75 cm)	DRT2-MD32ML DRT2-MD32B	Inputs: G7TC-ID16/IA16 Outputs: G7TC-OC16/OC08 G70D-SOC16/VSOC16 G70D-FOM16/VFOM16 G70A-ZOC16-3 G70D-SOC08 G70R-SOC08	
G79-M50-25-D2 (50 cm) G79-M75-50-D2 (75 cm)	DRT2-MD32ML-1 DRT2-MD32B-1	Inputs: G70A-ZIM16-5 Outputs: G70D-SOC16-1 G70D-FOM16-1 G70A-ZOC16-4	

### Cables with a Connector on One End (40-pin × 1 and Loose Wires)

Model	Specifications	Manufacturer
G79-A200C-D1 (2 m) G79-A500C-D1 (5 m)	Loose wire size: AWG28 Loose wires are cut.	OMRON
G79-Y100C-D1 (1 m) G79-Y200C-D1 (2 m) G79-Y500C-D1 (5 m)	Forked terminals are attached to the loose wires. Forked terminal: 161071-M2 (Nippon Terminal)	

### Pressure-welded Flat Cable Connectors

Model	Specifications	Manufacturer
XG4M-4030-T	Applicable wire size: AWG28	OMRON

### Loose Wires with Pressure-welded Connectors

Product	Model	Specifications	Manufacturer
Socket	XG5M-4032-N	Applicable wire size: AWG24	OMRON
	XG5M-4035-N	Applicable wire size: AWG28 to AWG26	
Semi-cover	XG5S-2001	Two for each connector	
Hood Cover	XG5S-5022	Cannot be used with a multi-drop DeviceNet Connector.	

### Applicable Post Terminals

Manufacturer	Model	
PHOENIX CONTACT	AI0.5-10	0.5 mm <sup>2</sup> (AWG 20)
	AI0.75-10	0.75 mm <sup>2</sup> (AWG 18)
	AI1.5-10	1.25 mm <sup>2</sup> (AWG 16)

<b>Manufacturer</b>	<b>Model</b>	
Nihon Weidmuller	H 0.5/16 D	0.5 mm <sup>2</sup> (AWG 20)
	H 0.75/16 D	0.75 mm <sup>2</sup> (AWG 18)
	H 1.5/16 D	1.25 mm <sup>2</sup> (AWG 16)



# Appendix E

## Current Consumption Summary

### General-purpose Slaves

Model	Communications current consumption
DRT2-ID18	55 mA max.
DRT2-ID18-1	55 mA max.
DRT2-ID16	60 mA max.
DRT2-ID16-1	60 mA max.
DRT2-OD08	50 mA max.
DRT2-OD08	45 mA max.
DRT2-OD16	60 mA max.
DRT2-OD16-1	60 mA max.
DRT2-MD16	55 mA max.
DRT2-MD16-1	50 mA max.
DRT2-ROS16	395 mA max.
XWT-ID08 (See note.)	5 mA max.
XWT-ID08-1 (See note.)	5 mA max.
XWT-ID16 (See note.)	10 mA max.
XWT-ID16-1 (See note.)	10 mA max.
XWT-OD08 (See note.)	4.5 mA max.
XWT-OD08-1 (See note.)	4.5 mA max.
XWT-OD16 (See note.)	10 mA max.
XWT-OD16-1 (See note.)	10 mA max.
DRT2-ID16TA	80 mA max.
DRT2-ID16TA-1	80 mA max.
DRT2-OD16TA	80 mA max.
DRT2-OD16TA-1	80 mA max.
DRT2-MD16TA	80 mA max.
DRT2-MD16TA-1	80 mA max.
DRT2-ID16S	230 mA max.
DRT2-ID16S-1	230 mA max.
DRT2-MD16S	135 mA max.
DRT2-MD16S-1	135 mA max.
DRT2-ID16ML(X)	60 mA max.
DRT2-ID16ML(X)-1	60 mA max.
DRT2-ID32ML	100 mA max.
DRT2-ID32ML-1	100 mA max.
DRT2-OD16ML(X)	75 mA max.
DRT2-OD16ML(X)-1	75 mA max.
DRT2-OD32ML	120 mA max.
DRT2-OD32ML-1	120 mA max.
DRT2-MD32ML	110 mA max.
DRT2-MD32ML-1	110 mA max.
DRT2-ID32B	100 mA max.
DRT2-ID32B-1	100 mA max.

Model	Communications current consumption
DRT2-OD32B	120 mA max.
DRT2-OD32B-1	120 mA max.
DRT2-MD32B	110 mA max.
DRT2-MD32B-1	110 mA max.
DRT2-ID32BV	100 mA max.
DRT2-ID32BV-1	100 mA max.
DRT2-OD32BV	120 mA max.
DRT2-OD32BV-1	120 mA max.
DRT2-MD32BV	110 mA max.
DRT2-MD32BV-1	110 mA max.
DRT2-ID16SL	28 mA max.
DRT2-ID16SL-1	27 mA max.
DRT2-ID32SL	100 mA max.
DRT2-ID32SL-1	90 mA max.
DRT2-OD16SL	32 mA max.
DRT2-OD16SL-1	31 mA max.
DRT2-OD32SL	80 mA max.
DRT2-OD32SL-1	75 mA max.
DRT2-MD32SL	80 mA max.
DRT2-MD32SL-1	80 mA max.
DRT2-ID16SLH	33 mA max.
DRT2-ID16SLH-1	32 mA max.
DRT2-ID32SLH	100 mA max.
DRT2-ID32SLH-1	105 mA max.
DRT2-OD16SLH	35 mA max.
DRT2-OD16SLH-1	35 mA max.
DRT2-OD32SLH	80 mA max.
DRT2-OD32SLH-1	85 mA max.
DRT2-MD32SLH	90 mA max.
DRT2-MD32SLH-1	90 mA max.

**Note** The communications current consumption indicated for Expansion Units is the additional current consumed when the Expansion Unit is connected to a Basic Unit.

For example, the current consumption for a combination of a DRT2-ID16 Basic Unit and an XWT-OD16 Expansion Unit is  $60 + 10 = 70$  mA.

## Environment-resistive Slaves

Model	Communications current consumption
DRT2-ID08C	115 mA max.
DRT2-ID08C-1	115 mA max.
DRT2-HD16C	190 mA max.
DRT2-HD16C-1	190 mA max.
DRT2-OD08C	60 mA max.
DRT2-OD08C-1	60 mA max.
DRT2-ID04CL	50 mA max.
DRT2-ID04CL-1	50 mA max.
DRT2-ID08CL	50 mA max.

Model	Communications current consumption
DRT2-ID08CL-1	50 mA max.
DRT2-HD16CL	55 mA max.
DRT2-HD16CL-1	55 mA max.
DRT2-OD04CL	45 mA max.
DRT2-OD04CL-1	45 mA max.
DRT2-OD08CL	50 mA max.
DRT2-OD08CL-1	50 mA max.
DRT2-WD16CL	55 mA max.
DRT2-WD16CL-1	55 mA max.
DRT2-MD16CL	55 mA max.
DRT2-MD16CL-1	55 mA max.

## Analog Slaves

Model	Communications current consumption
DRT2-AD04	90 mA max.
DRT2-AD04H	70 mA max.
DRT2-DA02	120 mA max.
DRT2-TS04T	70 mA max.
DRT2-TS04P	70 mA max.



# Appendix F

## Precautions with Connecting Two-wire DC Sensors

When using a two-wire sensor with a Slave using transistor inputs, check that the following conditions have been met.

Failure to meet these conditions may result in operating errors.

### Relation between ON Voltage of Slave with Transistor Inputs and Sensor Residual Voltage

$$V_{ON} \leq V_{CC} - V_R$$

$V_{CC}$ : I/O power supply voltage (The allowable power supply voltage range is 20.4 to 26.4 V, so 20.4 V will be used here to allow for the worst possible conditions.)

$V_{ON}$ : ON voltage for a Slave with Transistor Inputs

$V_R$ : Sensor's output residual voltage

It is sometimes possible to satisfy the above equation by adjusting the I/O power supply voltage ( $V_{CC}$ ) to 26.4 V.

### Relation between ON Current of Slave with Transistor Inputs and Sensor Control Output (Load Current)

$$I_{OUT} (\text{min.}) \leq I_{ON} \leq I_{OUT} (\text{max.})$$

$I_{OUT}$ : Sensor control output (load current)

$I_{ON}$ : Slave ON current

$$I_{ON} = (V_{CC} - V_R - V_F) / R_{IN}$$

$V_F$ : Internal residual voltage of a Slave with Transistor Inputs

$R_{IN}$ : Input impedance of a Slave with Transistor Inputs

When  $I_{ON}$  is smaller than  $I_{OUT} (\text{min.})$ , connect a bleeder resistor R.

The bleeder resistor constant can be calculated using the following equation.

$$R \leq (V_{CC} - V_R) / (I_{OUT} (\text{min.}) - I_{ON})$$

$$\text{Power } W \geq (V_{CC} - V_R)^2 / R \times 4 \text{ [allowable margin]}$$

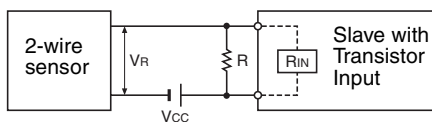



## **Relation between OFF Current of Slave with Transistor Inputs and Sensor Leakage Current**

$$I_{OFF} \geq I_{leak}$$

$I_{OUT}$ : OFF current of a Slave with Transistor Inputs

$I_{leak}$ : Sensor's leakage current

Connect a bleeder resistor if  $I_{leak}$  is greater than  $I_{OFF}$

The bleeder resistor constant can be calculated using the following equation.

$$R \leq (I_{OFF} \times R_{IN} + V_F) / (I_{leak} - I_{OFF})$$

$$\text{Power } W \geq (V_{CC} - V_R)^2 / R \times 4 \text{ [allowable margin]}$$

# Index

## A

- AD conversion cycle time
  - calculating, 358
- AD conversion points, 335, 358
- analog data
  - Analog Output Data, 367
  - operation flowcharts, 297
  - rate of change, 346
  - selecting, 298, 325
- Analog Input Terminals, 315
  - AD conversion data, 324
  - dimensions, 325
  - I/O data, 301
  - specifications, 315, 316
  - wiring, 318
- Analog Output Terminals, 359
  - DA conversion data, 364
  - dimensions, 364
  - I/O data, 302, 364
  - output signal range, 360
  - specifications, 359
  - wiring, 362
- Analog Slaves, 291
  - baud rate, 308
  - current consumption, 565
  - data processing functions, 295
  - features, 5
  - models, 10, 556
  - node addresses, 308
  - offset compensation, 338, 369
  - peak/bottom hold, 341, 409
  - remote I/O communications
    - data allocation, 40
  - scaling, 5, 337, 368, 406
  - top/valley hold, 343, 411
- Analog Status Flags, 331, 333, 348, 400, 402, 418

## B

- Basic Units
  - combined with Expansion Units, 100
- baud rate, 2, 97
  - automatic recognition, 52
  - changing, 52
  - setting, 99, 308

## C

- cables
    - communications cables, xxi, 26
      - Analog Slaves, 308
      - Environment-resistive Slaves, 236
      - Environment-resistive Terminals, 237
      - General-purpose Slaves, 87
    - models, 556
    - nodes, 89
  - connecting, 26
    - to Analog Slaves, 308
    - to Environment-resistive Slaves, 236
    - to General-purpose Slaves, 87
    - to nodes, 89
  - precautions, xx, xxi
  - Thick Cables, 23
    - cables with connectors, 238
    - connectors, 24, 90
  - Thin Cables, 22, 26
    - cables with connectors, 237
    - connectors, 90
- changing present values, xviii
- circuits
- DRT2-HD16C (NPN), 252
  - DRT2-HD16C-1 (PNP), 253
  - DRT2-ID08C (NPN), 247, 262, 266, 270, 273, 276, 280, 284
  - DRT2-ID08C-1 (PNP), 248, 263, 266, 273, 277, 284
  - DRT2-ID16 (NPN), 103, 105, 108
  - DRT2-ID16-1 (PNP), 103, 106, 108
  - DRT2-OD08C (NPN), 256
  - DRT2-OD08C-1 (PNP), 257
  - DRT2-OD16 (NPN), 111, 114
  - DRT2-OD16-1 (PNP), 111, 114
- precautions, xx
- XWT-ID08 (NPN), 121
  - XWT-ID08-1 (PNP), 121
  - XWT-ID16 (NPN), 124
  - XWT-ID16-1 (PNP), 124
  - XWT-OD08 (NPN), 127
  - XWT-OD08-1 (PNP), 127
  - XWT-OD16 (NPN), 130
  - XWT-OD16-1 (PNP), 130
- classification, 7
- cleaning, 466
- comments, 3
  - I/O comments, 57
  - Slave comments, 55
- communications

- baud rate
    - automatic recognition, 52, 97
    - changing, 52
    - setting, 99
  - cycle time, 449
  - DeviceNet remote I/O, 34, 444
  - errors, 3, 6
    - history monitor, 59
    - hold/clear, 475
    - output values, 376
    - settings, 97
  - message communications time, 453
  - refresh time, 449, 451
  - specifications, 32
  - starting, 22, 27
  - timing, 443
- Comparator Result Flag, 348, 349, 418
- Configurator
- Maintenance Information Window, 50
  - Maintenance Mode Window, 49
  - monitoring I/O power status, 62
  - monitoring operation time, 70
  - monitoring sensor power supply, 76
  - monitoring total ON time, 67
  - Network Configuration Window, 49
  - reading communications error history, 59
  - reading Contact Operation Counter data, 65
  - setting cumulative counter, 354, 427
  - setting hysteresis values, 344, 412
  - setting input ranges, 318
  - setting node addresses, 98
  - setting offset compensation, 370
  - setting output hold/clear, 99, 245, 261
  - setting output ranges, 361
  - using for I/O allocation, 42, 365
  - using for power ON delay, 64
  - using for Sensor Disconnected Detection, 73, 81
  - using for short-circuit detection, 78
  - windows, 48
  - writing maintenance dates, 61, 356, 425
- Connected Component Maintenance Flag, 66
- Connected Device Maintenance Flag, 64
- connectors
- communications connectors, 24, 25
  - covers
    - models, 559
  - for communications cable, 26, 89
  - for multi-drop connections, 90
  - for nodes, 26, 89
  - for Thick Cables, 24
  - models, 557, 559
  - precautions, xx, 90
  - round, 236, 237
  - square, 87, 237
- Contact Operation Counter, 64
- Contact Operation Monitor, 3
- Control Panels
  - mounting in, 142, 286, 309
- control system, 2
- crimp terminals, xx, 26, 89, 91, 310
  - models, 558
- cumulative counter
  - divisions, 354
- Cumulative Counter Flag, 37, 354, 427
- ## D
- DeviceNet
- basic operating procedures, 22
  - communications specifications, 32
  - connected Masters, 21
  - connected Slaves, 21
  - explicit messages, 469
  - remote I/O communications, 34, 444
  - system configuration, 22
  - wiring, 24
- dimensions
- Analog Input Terminals, 325
  - DRT2-HD16C, 254, 271, 281
  - DRT2-HD16C-1, 254, 271, 281
  - DRT2-ID08C, 249, 264, 268, 275, 278, 286
  - DRT2-ID08C-1, 249, 264, 268, 275, 278, 286
  - DRT2-ID16, 104, 107, 110
  - DRT2-ID16-1, 110
  - DRT2-OD08C, 258
  - DRT2-OD08C-1, 258
  - DRT2-OD16, 112, 116
  - DRT2-OD16-1, 112, 116
  - XWT-ID08, 123
  - XWT-ID08-1, 123
  - XWT-ID16, 125
  - XWT-ID16-1, 125
  - XWT-OD08, 129
  - XWT-OD08-1, 129
  - XWT-OD16, 132
  - XWT-OD16-1, 132
- DIN Track, 142, 309

**E**

EC Directives, xxii  
EMC Directives, xxii  
EMI Standard, xxii  
EMS Standard, xxii  
enclosure ratings  
    maintaining, 289  
Environment-resistive Slaves, 233  
    cables, 236  
    current consumption, 235, 564  
    enclosure ratings, 235  
    indicators, 235  
    models, 9, 555  
    precautions, xix, xxi  
    remote I/O communications  
        data allocation, 36  
    specifications, 234  
    weight, 235  
Environment-resistive Terminals, 245  
    baud rate, 245, 260  
    communications cables, 237  
    indicators, 246, 250, 255, 261, 265, 269, 272, 276,  
    279, 283  
    load short-circuit protection, 218, 258  
    node addresses, 245, 260  
    output hold/clear, 245, 260  
    power supply, 5  
    specifications, 245, 250, 261, 272, 282  
errors  
    processing, 456  
Expansion Units, 100  
    combinations, 100  
    mounting, 100  
    specifications, 120, 123, 126, 129  
    supplying I/O power, 101  
    wiring, 101  
External Load Short-circuit Detection, 4, 76  
    monitoring, 478  
    setting, 478

**F**

FALS instruction, xviii  
features, 2, 11  
fixed I/O allocations  
    precautions, 28  
functions, 47

**G**

General-purpose Slaves, 83  
    communications cables, 87  
    current consumption, 85, 563  
    models, 7, 553  
    precautions, xix  
    remote I/O communications  
        data allocation, 36  
    specifications, 85  
    weight, 85  
Generic Status Flags, 37, 330, 333, 334, 354, 367, 401,  
403, 427  
grounding  
    precautions, xx

**H**

Hold Flag, 334, 341, 343, 405, 409, 411  
hysteresis, 344, 349, 412, 418

**I**

I/O comments, 57  
I/O data, 329  
    allocated in Masters, 301, 303, 365  
    methods, 326, 394  
    procedure, 304  
    allocation methods, 325  
    patterns, 367  
I/O Power Status Monitor, 3  
I/O response time, 444  
I/O tables  
    for Masters, 27  
indicators, 24  
    Environment-resistive Slaves, 235, 236  
    Environment-resistive Terminals, 246, 261, 265, 268,  
    272, 275, 278, 282  
    I/O, 235, 246, 250, 255  
    Module Status, 32  
    Network Status, 32  
    status, 29  
    used for error processing, 456  
input filter, 3, 62  
inspection, 466  
installation, 17

**L**

Load Short-circuit Protection, 218, 258

Load Shorted Flag, 218, 259

Low Voltage Directive, xxii

**M**

maintenance, 60, 455

  cleaning, 466

  inspection, 466

  replacing Units, 467

  writing maintenance dates, 60, 356, 425

Masters

  from other companies, 493

  mounting, 24

  settings, 24

message communications time, 453

mounting, 25

multi-drop connections, 23, 24, 90

**N**

Network Power Voltage Error Flag, 53

nodes

  addresses, 2, 25, 98, 245, 260, 308

**O**

offset compensation, 338, 369

Off-wire Detection, 351, 425

Off-wire Detection Flags, 351, 425

Operation Time Monitor, 68

Operation Time Monitor Flag, 68

output hold/clear, 99, 245, 261

outputs

  precautions, xviii

**P**

packing

  precautions, xx

peak/bottom hold, 341, 409

power ON delay, 64

power supply, 17

  communications power supply, xx, 23

  Environment-resistive Terminals, 5

I/O power supply, 3, 18

  for Expansion Units, 101

  monitoring, 61

  power ON delay, 64

  wiring, 26, 143, 286

internal power supply

  wiring, 286

network voltage monitor, 2, 53

precautions, xx

Power Supply Sharing Taps

  models, 558

precautions

  application, xx

  cables, xx, xxi

  circuits, xx

  connecting two-wire DC sensors, 567

  connectors, xx, 90

  environment, xix

  general, xvii

  grounding, xx

  packing, xx

  power supply, xx

  safety, xviii

  scan list, xxi

  switches, xx

  wiring, xx, 89, 101

Programming Console

  creating I/O tables, 27

**R**

radiated emission, xxii

refreshing

  data, xviii

remote I/O communications, 2

  data allocation, 34

Remote I/O Terminals

  node addresses, 98

  Operation Time Monitor, 68

  specifications, 102, 104, 107, 110, 113

  wiring, 26

  with transistors, 97

**S**

scaling, 5, 337, 368, 406

scan lists

  creating, 28

  precautions, xxi

  registering, 29

screwdrivers, 89  
  models, 558

Sensor Disconnected Detection, 4, 72  
  monitoring, 477  
  setting, 477

settings, 25

Short-circuited Flag, 76

slave comments, 55

slave errors, 456

specifications, 31  
  Analog Input Terminals, 315, 316  
  Analog Output Terminals, 359  
  communications, 32  
  Environment-resistive Slaves, 234  
  Environment-resistive Terminals, 245, 250, 261, 265, 282  
  Expansion Units, 120, 123, 126, 129  
  General-purpose Slaves, 85  
  Remote I/O Terminals, 102, 104, 107, 110, 113  
  Slaves (common), 32

switches  
  DIP switches, 2, 24, 316, 360  
    reading, 481  
  rotary switches, 24, 25  
    precautions, xx  
    setting node addresses, 2, 97  
  software switches, 28, 97

**T**

T-branch Connectors  
  models, 558

T-branch Taps, 23, 26, 89, 91  
  connecting to Terminating Resistors, 91  
  models, 558  
  wiring, 239

Terminating Resistors, 26  
  connecting to T-branch Taps, 91  
  in Terminal Blocks, 91  
  models, 558, 560  
  mounting, 91

T-joints  
  models, 559

top/valley hold, 343, 411  
  Top/Valley Detection Timing Flags, 331, 333, 334, 343, 399, 401, 403, 411

Total ON Time Monitor, 3, 66

transferring I/O memory data, xviii

transferring I/O memory files, xviii

troubleshooting, 455

## U

Unit Maintenance Flag, 54

user I/O allocations  
  precautions, 28

## W

wiring  
  Analog Input Terminals, 318  
  Analog Output Terminals, 362  
  CRT2-ID08C-1 (PNP), 249, 264, 267, 274, 277, 285  
  DeviceNet Network, 22, 24  
  DRT2-HD16C (NPN), 253, 270, 280  
  DRT2-HD16C-1 (PNP), 254, 270, 271, 280, 281  
  DRT2-ID08C (NPN), 248, 263, 267, 274, 277, 285  
  DRT2-ID16 (NPN), 103, 106, 109  
  DRT2-ID16-1 (PNP), 104, 106, 109  
  DRT2-OD08C (NPN), 257  
  DRT2-OD08C-1 (PNP), 258  
  DRT2-OD16 (NPN), 112, 115  
  DRT2-OD16-1 (PNP), 112, 115  
  Expansion Units, 101  
  I/O lines, 143, 286, 310  
  I/O power supply, 26, 143, 286  
  internal power supply, 286  
  precautions, xx, 89, 101  
  T-branch Taps, 239  
  XWT-ID08 (NPN), 122  
  XWT-ID08-1 (PNP), 122  
  XWT-ID16 (NPN), 125  
  XWT-ID16-1 (PNP), 125  
  XWT-OD08 (NPN), 128  
  XWT-OD08-1 (PNP), 128  
  XWT-OD16 (NPN), 131  
  XWT-OD16-1, 131

## Y

Y-joint Plugs and Sockets  
  models, 559



## Revision History

A manual revision code appears as a suffix to the catalog number on the front cover of the manual.

Cat. No. W404-E1-07



The following table outlines the changes made to the manual during each revision. Page numbers refer to the previous version.

Revision code	Date	Revised content
01	September 2002	Original production
03	July 2003	Added information on Sensor Connector Terminals, Remote I/O Terminals (with relay outputs, and with three-tier terminal blocks), and MIL Connector Terminals throughout the manual.
04	January 2004	Added information on Screw-less Clamp Terminals, Sensor Connector Terminals, and detection functions throughout the manual.
05	July 2004	Added information on new analog slaves (High-resolution Analog Input Terminals and Temperature Input Terminals).
06	September 2006	<p>Added information on Advanced Environment-resistive Slaves throughout the manual, including specifications, windows, and indicators.</p> <p><b>Page 200, 227, 231, and 234:</b> Changes made or information added to specifications.</p> <p><b>Pages 201, 202, 221, 227, 228, 231, and 234:</b> Information added on indicators.</p> <p><b>Pages 207 and 208:</b> Information added on windows.</p> <p><b>Pages 208 and 209:</b> Information added on status check boxes.</p>
07	April 2008	Added information on Screw-less Clamp Terminals with 16 inputs and 16 outputs.