

## USER'S MANUAL

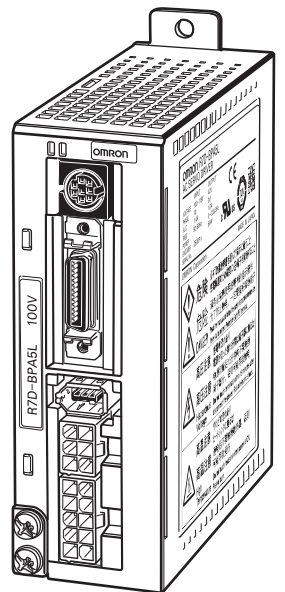
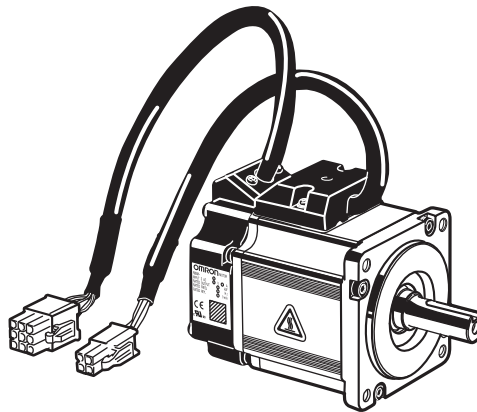

# SMARTSTEP 2 SERIES

- R88M-G□  
(Servomotors)
- R7D-BP□  
(Servo Drives)

## SERVOMOTORS/SERVO DRIVES

#### Trademarks and Copyrights

- Product names and system names in this manual are trademarks or registered trademarks of their respective companies.

#### © OMRON, 2008

All rights reserved. No part of this publication may be reproduced, stored in a retrieval system, or transmitted, in any form, or by any means, mechanical, electronic, photocopying, recording, or otherwise, without the prior written permission of OMRON.

No patent liability is assumed with respect to the use of the information contained herein. Moreover, because OMRON is constantly striving to improve its high-quality products, the information contained in this manual is subject to change without notice. Every precaution has been taken in the preparation of this manual. Nevertheless, OMRON assumes no responsibility for errors or omissions. Neither is any liability assumed for damages resulting from the use of the information contained in this publication.

---

---

# Introduction

---

Thank you for choosing the SMARTSTEP 2 Series. This User's Manual describes installation/wiring methods and parameter setting procedures required for the operation of the SMARTSTEP 2 Series as well as troubleshooting and inspection methods.

## Intended Readers

This manual is intended for the following personnel.  
Those with knowledge of electrical systems (a qualified electrical engineer or the equivalent) as follows:

- ◆ Personnel in charge of introducing FA equipment
- ◆ Personnel in charge of designing FA systems
- ◆ Personnel in charge of managing FA systems and facilities

## NOTICE

This manual contains information necessary to ensure safe and proper use of the SMARTSTEP 2 Series and its peripheral devices. Please read this manual thoroughly and understand its contents before using the products.

Please keep this manual handy for future reference.

Make sure this User's Manual is delivered to the actual end user of the products.

---

## ***Read and Understand this Manual***

Please read and understand this manual before using the product. Please consult your OMRON representative if you have any questions or comments.

## ***Warranty and Limitations of Liability***

### ***WARRANTY***

OMRON's exclusive warranty is that the products are free from defects in materials and workmanship for a period of one year (or other period if specified) from date of sale by OMRON.

OMRON MAKES NO WARRANTY OR REPRESENTATION, EXPRESS OR IMPLIED, REGARDING NON-INFRINGEMENT, MERCHANTABILITY, OR FITNESS FOR PARTICULAR PURPOSE OF THE PRODUCTS. ANY BUYER OR USER ACKNOWLEDGES THAT THE BUYER OR USER ALONE HAS DETERMINED THAT THE PRODUCTS WILL SUITABLY MEET THE REQUIREMENTS OF THEIR INTENDED USE. OMRON DISCLAIMS ALL OTHER WARRANTIES, EXPRESS OR IMPLIED.

### ***LIMITATIONS OF LIABILITY***

OMRON SHALL NOT BE RESPONSIBLE FOR SPECIAL, INDIRECT, OR CONSEQUENTIAL DAMAGES, LOSS OF PROFITS OR COMMERCIAL LOSS IN ANY WAY CONNECTED WITH THE PRODUCTS, WHETHER SUCH CLAIM IS BASED ON CONTRACT, WARRANTY, NEGLIGENCE, OR STRICT LIABILITY.

In no event shall the responsibility of OMRON for any act exceed the individual price of the product on which liability is asserted.

IN NO EVENT SHALL OMRON BE RESPONSIBLE FOR WARRANTY, REPAIR, OR OTHER CLAIMS REGARDING THE PRODUCTS UNLESS OMRON'S ANALYSIS CONFIRMS THAT THE PRODUCTS WERE PROPERLY HANDLED, STORED, INSTALLED, AND MAINTAINED AND NOT SUBJECT TO CONTAMINATION, ABUSE, MISUSE, OR INAPPROPRIATE MODIFICATION OR REPAIR.

---

## ***Application Considerations***

### ***SUITABILITY FOR USE***

OMRON shall not be responsible for conformity with any standards, codes, or regulations that apply to the combination of products in the customer's application or use of the products.

At the customer's request, OMRON will provide applicable third party certification documents identifying ratings and limitations of use that apply to the products. This information by itself is not sufficient for a complete determination of the suitability of the products in combination with the end product, machine, system, or other application or use.

The following are some examples of applications for which particular attention must be given. This is not intended to be an exhaustive list of all possible uses of the products, nor is it intended to imply that the uses listed may be suitable for the products:

- Outdoor use, uses involving potential chemical contamination or electrical interference, or conditions or uses not described in this manual.
- Nuclear energy control systems, combustion systems, railroad systems, aviation systems, medical equipment, amusement machines, vehicles, safety equipment, and installations subject to separate industry or government regulations.
- Systems, machines, and equipment that could present a risk to life or property.

Please know and observe all prohibitions of use applicable to the products.

NEVER USE THE PRODUCTS FOR AN APPLICATION INVOLVING SERIOUS RISK TO LIFE OR PROPERTY WITHOUT ENSURING THAT THE SYSTEM AS A WHOLE HAS BEEN DESIGNED TO ADDRESS THE RISKS, AND THAT THE OMRON PRODUCTS ARE PROPERLY RATED AND INSTALLED FOR THE INTENDED USE WITHIN THE OVERALL EQUIPMENT OR SYSTEM.

### ***PROGRAMMABLE PRODUCTS***

OMRON shall not be responsible for the user's programming of a programmable product, or any consequence thereof.

## ***Disclaimers***

### ***CHANGE IN SPECIFICATIONS***

Product specifications and accessories may be changed at any time based on improvements and other reasons.

It is our practice to change model numbers when published ratings or features are changed, or when significant construction changes are made. However, some specifications of the products may be changed without any notice. When in doubt, special model numbers may be assigned to fix or establish key specifications for your application on your request. Please consult with your OMRON representative at any time to confirm actual specifications of purchased products.

### ***DIMENSIONS AND WEIGHTS***

Dimensions and weights are nominal and are not to be used for manufacturing purposes, even when tolerances are shown.

---

## ***PERFORMANCE DATA***

Performance data given in this manual is provided as a guide for the user in determining suitability and does not constitute a warranty. It may represent the result of OMRON's test conditions, and the users must correlate it to actual application requirements. Actual performance is subject to the OMRON Warranty and Limitations of Liability.

## ***ERRORS AND OMISSIONS***



The information in this manual has been carefully checked and is believed to be accurate; however, no responsibility is assumed for clerical, typographical, or proofreading errors, or omissions.

# Precautions for Safe Use

- To ensure safe and proper use of the SMARTSTEP 2 Series and its peripheral devices, read the “Precautions for Safe Use” and the rest of the manual thoroughly to acquire sufficient knowledge of the devices, safety information, and precautions before using the products.
- Make sure this User’s Manual is delivered to the actual end users of the products.
- Please keep this manual close at hand for future reference.

## Explanation of Signal Words





- The precautions indicated here provide important information for safety. Be sure to heed the information provided with the precautions.
- The following signal words are used to indicate and classify precautions in this manual.

 <b>WARNING</b>	Indicates a potentially hazardous situation which, if not avoided, could result in death or serious injury. Additionally, there may be severe property damage.
 <b>Caution</b>	Indicates a potentially hazardous situation which, if not avoided, may result in minor or moderate injury, or property damage.

Failure to heed the precautions classified as “Caution” may also lead to serious results. Strictly heed these precautions.











## Safety Precautions

- This manual may include illustrations of the product with protective covers or shields removed in order to show the components of the product in detail. Make sure that these protective covers and shields are put in place as specified before using the product.
- Consult your OMRON representative when using the product after a long period of storage.

 <b>WARNING</b>	
	Always connect the frame ground terminals of the Servo Drive and the Servomotor to 100 Ω or less. Not doing so may result in electric shock.
	Do not touch the inside of the Servo Drive. Doing so may result in electric shock.
	When turning OFF the main circuit power supply, turn OFF the RUN Command Input (RUN) at the same time. Residual voltage may cause the Servomotor to continue rotating and result in injury or equipment damage even if the main circuit power supply is turned OFF externally, e.g., with an emergency stop.
	Do not remove the front cover, terminal covers, cables, or optional items while the power is being supplied. Doing so may result in electric shock.



## Precautions for Safe Use

---



	Installation, operation, maintenance, or inspection must be performed by authorized personnel only. Not doing so may result in electric shock or injury.
	Wiring or inspection must not be performed for at least 15 minutes after turning OFF the power supply. Doing so may result in electric shock.
	Do not damage, pull on, put excessive stress on, or put heavy objects on the cables. Doing so may result in electric shock, stopping product operation, or burning.
	Do not touch the rotating parts of the Servomotor during operation. Doing so may result in injury.
	Do not modify the product. Doing so may result in injury or damage to the product.
	Provide a stopping mechanism on the machine side to ensure safety. *The holding brake is not designed as a stopping mechanism for safety purposes. Not doing so may result in injury.
	Provide an external emergency stopping mechanism that can stop operation and shut off the power supply immediately. Not doing so may result in injury.
	Do not come close to the machine immediately after resetting momentary power interruption to avoid danger due to an unexpected restart. Doing so may result in injury. Take precautions to secure safety in case of an unexpected restart.
	Confirm safety after an earthquake has occurred. Not doing so may result in electric shock, injury, or fire.
	Do not use external force to drive the Servomotor. Doing so may result in fire.



 **WARNING**



- |   |  |
|---|--|
|  | Do not place any flammable materials near the Servomotor, Servo Drive, or Regeneration Resistor. Doing so may result in fire.            |
|  | Mount the Servomotor, Servo Drive, and Regeneration Resistor on metal or other non-flammable materials. Not doing so may result in fire. |
|  | Do not turn ON/OFF the main power supply of the Servo Drive repeatedly at frequent intervals. Doing so may result in product failure.    |

 **Caution**

- |   |   |
|---|---|
|    | Use the Servomotors and Servo Drives in a combination as specified in the manual. Not doing so may result in fire or damage to the products.  |
|  | Do not store or install the product in the following places. Doing so may result in fire, electric shock, or damage to the product. <ul style="list-style-type: none"><li>• Locations subject to direct sunlight.</li><li>• Locations subject to ambient temperature exceeding the specified level.</li><li>• Locations subject to relative humidity exceeding the specified level.</li><li>• Locations subject to condensation due to temperature fluctuations.</li><li>• Locations subject to corrosive or flammable gases.</li><li>• Locations subject to dust (especially iron dust) or salt.</li><li>• Locations subject to exposure to water, oil, or chemicals.</li><li>• Locations subject to shock or vibration.</li></ul> |
|  | Do not touch the Servo Drive radiator, Regeneration Resistor, or Servomotor while the power is being supplied or for some time after the power is turned OFF. Doing so may result in burn injuries.   |















■ Storage and Transportation Precautions

 **Caution**









- |   |  |
|---|--|
|  | Do not hold the product by the cables or motor shaft while transporting it. Doing so may result in injury or malfunction.        |
|  | Do not overly pile the products. (Follow the instructions on the product package.) Doing so may result in injury or malfunction. |

## Precautions for Safe Use



### ■ Installation and Wiring Precautions

 <b>Caution</b>	
	Do not step on or place a heavy object on the product. Doing so may result in injury.
	Do not cover the inlet/outlet ports and do not let any foreign objects enter the product. Doing so may result in fire.
	Be sure to install the product in the correct direction. Not doing so may result in malfunction.
	Keep the specified distance between the Servo Drive and the control panel or with other devices. Not doing so may result in fire or malfunction.
	Do not apply a strong impact on the Servomotor shaft or Servo Drive. Doing so may result in malfunction.
	Be sure to wire correctly and securely. Not doing so may result in motor runaway, injury, or malfunction.
	Be sure that all the mounting screws, terminal block screws, and cable connector screws are tightened securely. Not doing so may result in malfunction.
	Use crimp terminals for wiring. Do not connect bare stranded wires directly to the protective ground terminal. Doing so may result in fire.
	Always use the power supply voltage specified in the User's Manual. Not doing so may result in malfunction or burning.
	Take appropriate measures to ensure that the specified power with the rated voltage and frequency is supplied. Use particular caution if the product is used in a place where a stable power supply cannot be provided. Not doing so may result in equipment damage.
	Install breakers and take other safety measures against short-circuiting of external wiring. Not doing so may result in fire.
	Take sufficient shielding measures when using the product in the following locations. Not doing so may result in damage to the product. <ul style="list-style-type: none"><li>◆ Locations subject to static electricity or other forms of noise.</li><li>◆ Locations subject to strong electromagnetic fields and magnetic fields.</li><li>◆ Locations subject to possible exposure to radioactivity.</li><li>◆ Locations close to power lines.</li></ul>
	Connect an emergency stop shutoff relay in series with the brake control relay. Not doing so may result in injury or product failure.

■ Operation and Adjustment Precautions

 <h2 style="margin: 0;">Caution</h2>	
	<p>Confirm that no adverse effects will occur in the system before performing the test operation. Not doing so may result in equipment damage.</p>
	<p>Check that the newly set parameters function properly before the actual operation. Not doing so may result in equipment damage.</p>
	<p>Do not make any extreme adjustments or setting changes. Doing so may result in injury.</p>
	<p>Check for the proper operation of the Servomotor separately from the mechanical system before connecting it to the machine. Not doing so may cause injury.</p>
	<p>When an alarm occurs, remove the cause, reset the alarm after confirming safety, and then resume operation. Not doing so may result in injury.</p>
	<p>Do not use the built-in brake of the Servomotor for ordinary braking. Doing so may result in malfunction.</p>
	<p>Do not operate the Servomotor connected to a load that exceeds the applicable load inertia. Doing so may result in malfunction.</p>

■ Maintenance and Inspection Precautions

 <h2 style="margin: 0;">Caution</h2>	
	<p>Resume operation only after transferring to the new Unit the contents of the data required for operation restart. Not doing so may result in equipment damage.</p>
	<p>Do not dismantle or repair the product. Doing so may result in electric shock or injury.</p>

## Precautions for Safe Use

### ■ Warning Label Position

Warning labels are located on the product as shown in the following illustration.  
Be sure to follow the instructions given there.

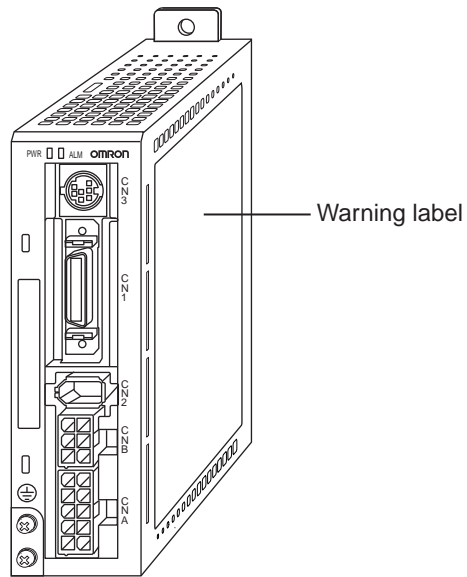

(Example of R7D-BP01H)

### ■ Warning Label Contents

	<b>危険</b> <b>危険</b> <b>DANGER</b>	必ず取扱説明書を読んで指示に従うこと 感電保護のため確実に⊕端子を接地すること 请务必按照使用说明书的指示操作 为了防止触电，一定要接好接地端子 Read the manual and follow the safety instructions before use. Never fail to connect Protective Earth(PE) terminal.
	<b>高压注意</b> <b>高压注意</b> <b>Hazardous Voltage</b>	感電の恐れあり 電源を切った後15分間は端子部に触るな! 电源切断后15分钟内不要触摸 端子部分，否则可能导致触电 Do not touch terminals within 15 minutes after disconnect the power. Risk of electric shock.
	<b>高温注意</b> <b>高温注意</b> <b>High Temperature</b>	やけどの恐れあり ヒートシンクに触るな! 通电后不要触摸散热器，否则 可能导致受伤 Do not touch heatsink when power is ON. Risk of burn.

### ■ Disposing of the Product

- ◆ Dispose of the product as industrial waste.

# Items to Check When Unpacking

Check the following items after removing the product from the package.

- ♦ Has the correct product been delivered?
- ♦ Has the product been damaged in shipping?

## ■ Accessories Provided with Product

### Safety Precautions document × 1

- ♦ No connectors or mounting screws are provided. They have to be prepared by the user.
- ♦ Should you find any problems (missing parts, damage to the Servo Drive, etc.), please contact your local sales representative or OMRON sales office.

## ■ Understanding Model Numbers

### Servo Drive Models

The model number provides information such as the Servo Drive type, the applicable Servomotor capacity, and the power supply voltage.

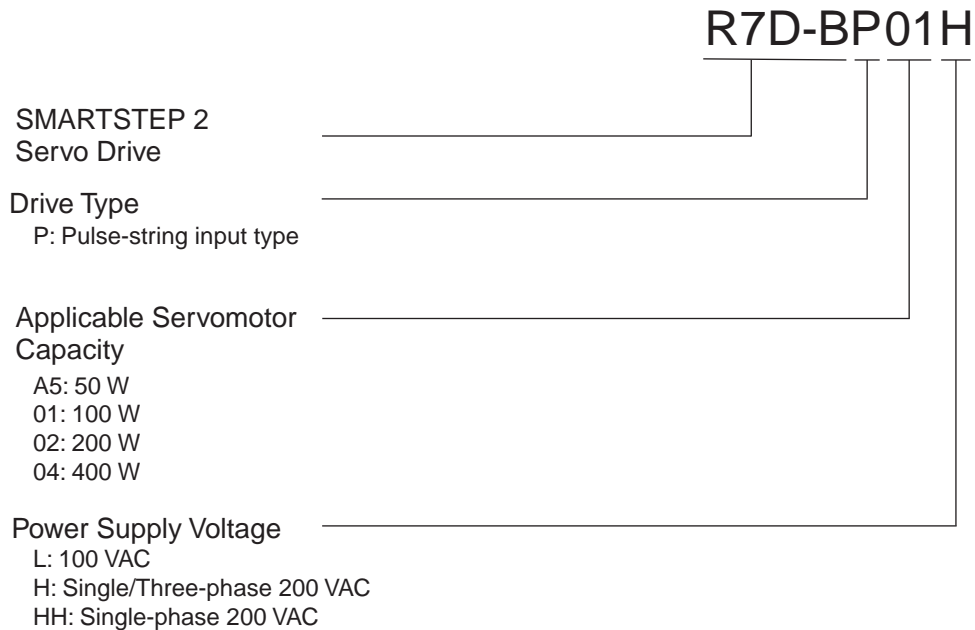

**Note** Single phase: Haploid phase

## Items to Check When Unpacking

### Servomotor Models

The model number provides information such as the Servomotor type, Servomotor capacity, rated rotation speed, and options.

R88M-GP10030H-BOS2

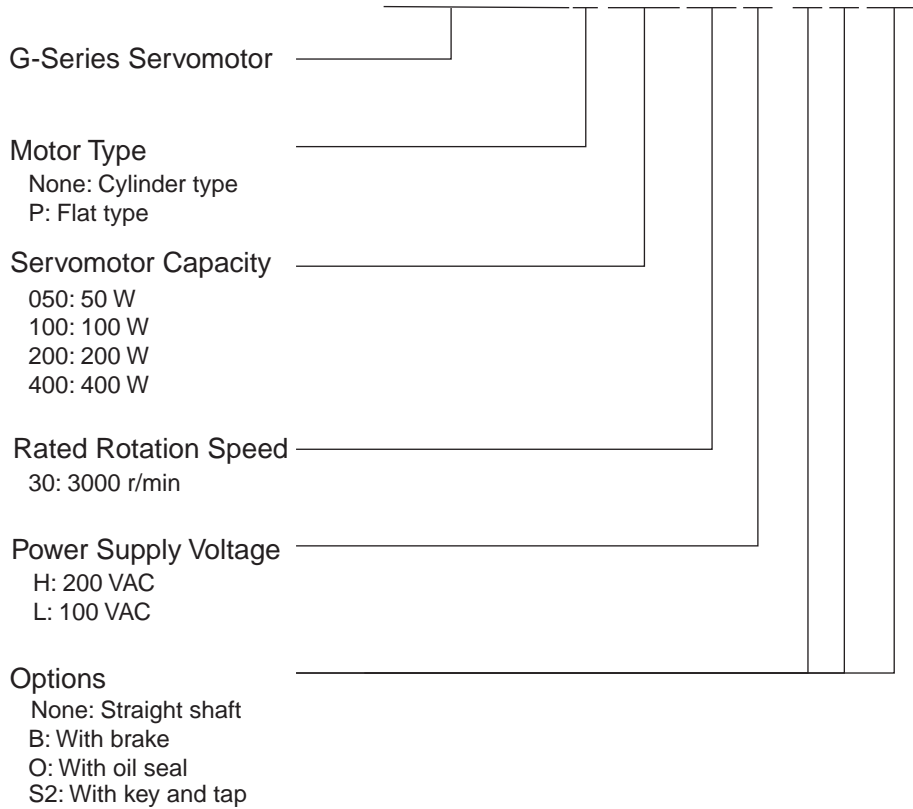

---



---

# About this Manual

---

This manual consists of the following chapters. Refer to this table and choose the required chapters of the manual.

		Overview
Chapter 1	Features and System Configuration	Describes the features and names of parts of the product as well as the EC Directives and the UL standards.
Chapter 2	Standard Models and Dimensions	Provides the model numbers, external and mounted dimensions for Servo Drives, Servomotors, Decelerators, and peripheral devices.
Chapter 3	Specifications	Provides the general specifications, performance specifications, connector specifications, and I/O circuit specifications for Servo Drives and the general specifications and performance specifications for Servomotors, as well as specifications for accessories such as encoders.
Chapter 4	System Design	Describes the installation conditions for Servo Drives, Servomotors, and Decelerators, EMC conforming wiring methods, calculations of regenerative energy, and performance information on the External Regeneration Resistor.
Chapter 5	Operating Functions	Describes the electronic gear function and other operating functions as well as the parameter setting procedure.
Chapter 6	Operation	Describes operating procedures and how to use the Parameter Unit.
Chapter 7	Adjustment Functions	Describes realtime autotuning function, manual tuning and other procedures for gain adjustment.
Chapter 8	Troubleshooting	Describes items to check for troubleshooting, error diagnoses using alarm displays and the countermeasures, error diagnoses based on the operation status and the countermeasures, and periodic maintenance.
Appendix	Connection Examples	Provides examples of connection with OMRON PLCs and Position Controllers.

# CONTENTS

---

Introduction .....	1
Precautions for Safe Use .....	5
Items to Check When Unpacking .....	11
About this Manual .....	13
<b>Chapter 1 Features and System Configuration</b>	
1-1 Overview .....	1-1
1-2 System Configuration .....	1-2
1-3 Names of Parts and Functions .....	1-3
1-4 System Block Diagrams .....	1-5
1-5 Applicable Standards .....	1-6
<b>Chapter 2 Standard Models and Dimensions</b>	
2-1 Standard Models .....	2-1
2-2 External and Mounted Dimensions .....	2-13
<b>Chapter 3 Specifications</b>	
3-1 Servo Drive Specifications .....	3-1
3-2 Servomotor Specifications .....	3-16
3-3 Decelerator Specifications .....	3-26
3-4 Cable and Connector Specifications .....	3-30
3-5 Servo Relay Units and Cable Specifications .....	3-52
3-6 Parameter Unit Specifications .....	3-77
3-7 External Regeneration Resistors Specifications .....	3-78
3-8 Reactor Specifications .....	3-79
<b>Chapter 4 System Design</b>	
4-1 Installation Conditions .....	4-1
4-2 Wiring .....	4-9
4-3 Wiring Conforming to EMC Directives .....	4-17
4-4 Regenerative Energy Absorption .....	4-32
<b>Chapter 5 Operating Functions</b>	
5-1 Position Control .....	5-1
5-2 Internally Set Speed Control .....	5-4
5-3 Forward and Reverse Drive Prohibit .....	5-7
5-4 Encoder Dividing .....	5-8
5-5 Electronic Gear .....	5-9
5-6 Brake Interlock .....	5-11
5-7 Gain Switching .....	5-13
5-8 Torque Limit .....	5-15
5-9 Overrun Limit .....	5-16
5-10 User Parameters .....	5-17



# CONTENTS

---

## Chapter 6 Operation

6-1	Operational Procedure.....	6-1
6-2	Preparing for Operation .....	6-2
6-3	Using the Parameter Unit .....	6-4
6-4	Trial Operation .....	6-23

## Chapter 7 Adjustment Functions

7-1	Gain Adjustment .....	7-1
7-2	Realtime Autotuning .....	7-3
7-3	Autotuning.....	7-8
7-4	Disabling the Automatic Gain Adjustment Function.....	7-13
7-5	Manual Tuning .....	7-15

## Chapter 8 Troubleshooting

8-1	Error Processing .....	8-1
8-2	Alarm Table .....	8-3
8-3	Troubleshooting .....	8-5
8-4	Overload Characteristics (Electronic Thermal Function) .....	8-16
8-5	Periodic Maintenance .....	8-17



# Chapter 1

## Features and System Configuration

<b>1-1</b>	<b>Overview .....</b>	<b>1-1</b>
	Overview of the SMARTSTEP 2 Series .....	1-1
	Features of the SMARTSTEP 2 Series.....	1-1
<b>1-2</b>	<b>System Configuration.....</b>	<b>1-2</b>
<b>1-3</b>	<b>Names of Parts and Functions .....</b>	<b>1-3</b>
	Servo Drive Part Names .....	1-3
	Servo Drive Functions.....	1-4
<b>1-4</b>	<b>System Block Diagrams .....</b>	<b>1-5</b>
<b>1-5</b>	<b>Applicable Standards .....</b>	<b>1-6</b>
	EC Directives .....	1-6
	UL Standards .....	1-6

---

# 1-1 Overview

---

## Overview of the SMARTSTEP 2 Series

The SMARTSTEP 2 Series is a series of pulse-string input type Servo Drives for position controlling and it has been designed to function for low-capacity positioning systems. In spite of the compact size, the SMARTSTEP 2 Series features realtime autotuning and adaptive filter functions that automatically perform complicated gain adjustments. A notch filter can also be automatically set to suppress machine vibration by reducing mechanical resonance during operation. The damping control function of the SMARTSTEP 2 Series realizes stable stopping performance in a mechanism which vibrates because of the low rigidity of the load.

## Features of the SMARTSTEP 2 Series

The SMARTSTEP 2 Series has the following features.

### ■ Compact AC Servo Drives

Compared to the SMARTSTEP A Series, the SMARTSTEP 2 Series can reduce the installation space by 48% and the installation size by 39% in terms of volume. The AC Servo Drives of the SMARTSTEP 2 Series are equipped with newly developed functions for applications requiring more precise positioning.

### ■ Suppressing Vibration of Low-rigidity Mechanisms during Acceleration/Deceleration

The damping control function can suppress vibration of low-rigidity mechanisms or devices whose ends tend to vibrate.

### ■ High-speed Positioning via Resonance Suppression Control

The realtime autotuning function automatically estimates the load inertia of the machine in realtime and sets the optimal gain. The adaptive filter automatically suppresses vibration caused by resonance.

### ■ Compatible with Command Pulse of 90° Phase Difference Inputs

In addition to conventional CW/CCW inputs (2 pulse inputs) and SIGN/PULS inputs (1 pulse input), the SMARTSTEP 2 supports 90° phase difference inputs. This makes it possible to input encoder output signals directly into the Servo Drive for simplified synchronization control.

### ■ A Wide Range of Pulse Setting Functions

A wide range of pulse setting functions, such as the command pulse multiplying, electronic gear, and encoder dividing, enable you to perform pulse settings suitable for your device or system.

### ■ Simplified Speed Control with Internal Speed Settings

Four internal speed settings allow the speed to be easily switched by using external signals.

### ■ Encoder Dividing Output Function

The number of motor encoder pulses output by the Servo Drive can be freely set in the range of 1 to 2,500 pulses per rotation. A parameter can also be set to change the phase.

# 1-2 System Configuration

**SYSMAC PLC + Position Control Unit with pulse-string output**

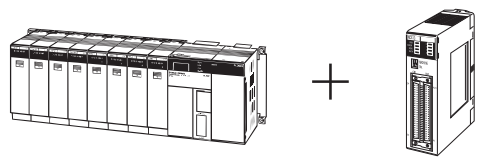

SYSMAC  
CJ1/CS1/C-Series  
Programmable Controller

Position Control Unit  
CJ1W-NC113/213/413  
CJ1W-NC133/233/433  
CS1W-NC113/213/413  
CS1W-NC133/233/433  
C200HW-NC113/213/413

**SYSMAC PLC with pulse output functions**

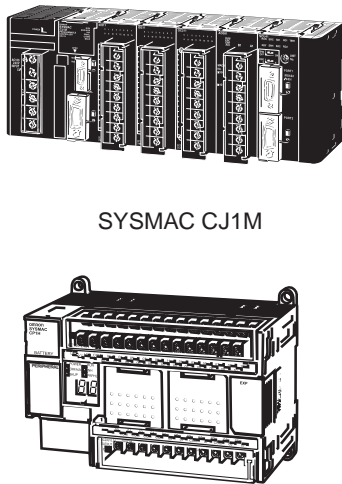

SYSMAC CJ1M

SYSMAC CP1H/CP1L

**Flexible Motion Controller with Pulse I/O**

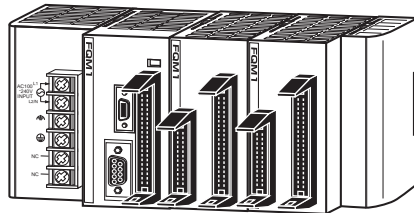

FQM1-MMP22

Pulse string

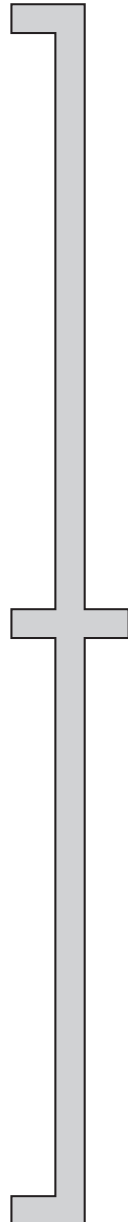
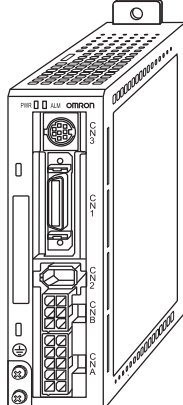
SMARTSTEP 2 Servo Drive  
R7D-BP□

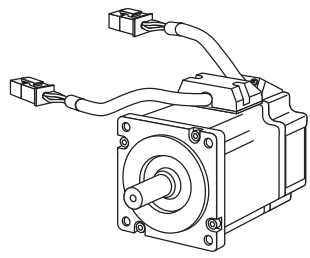

OMNUC G-Series Servomotor  
R88M-G□/-GP□

# 1-3 Names of Parts and Functions

## Servo Drive Part Names

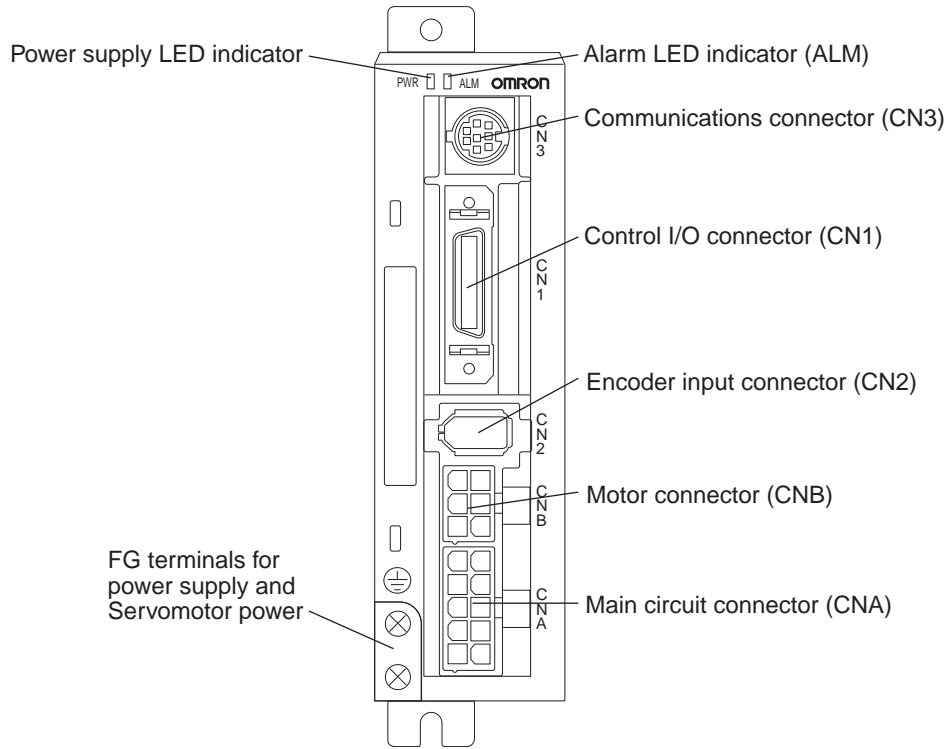

## Servo Drive Functions

### ■ Power Supply LED Indicator (PWR)

LED Indicator	Status
Lit green	Main power is ON.
Flashing orange at 1-second intervals	A warning has occurred (i.e., an overload, excessive regenerative energy, or fan speed error).
Lit red	An alarm has occurred.

### ■ Alarm LED Indicator (ALM)

This indicator is lit when an alarm has occurred. The number of orange and red flashes indicate the alarm code. For details on the alarm code, refer to *Alarm List* on page 8-4.

Example:

When an overload alarm (alarm code 16) has occurred and the Unit has stopped the indicator will flash 1 time in orange and 6 times in red.

Orange: 10s digit, Red: 1s digit

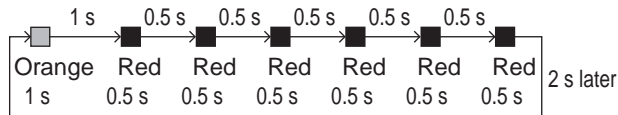

# 1-4 System Block Diagrams

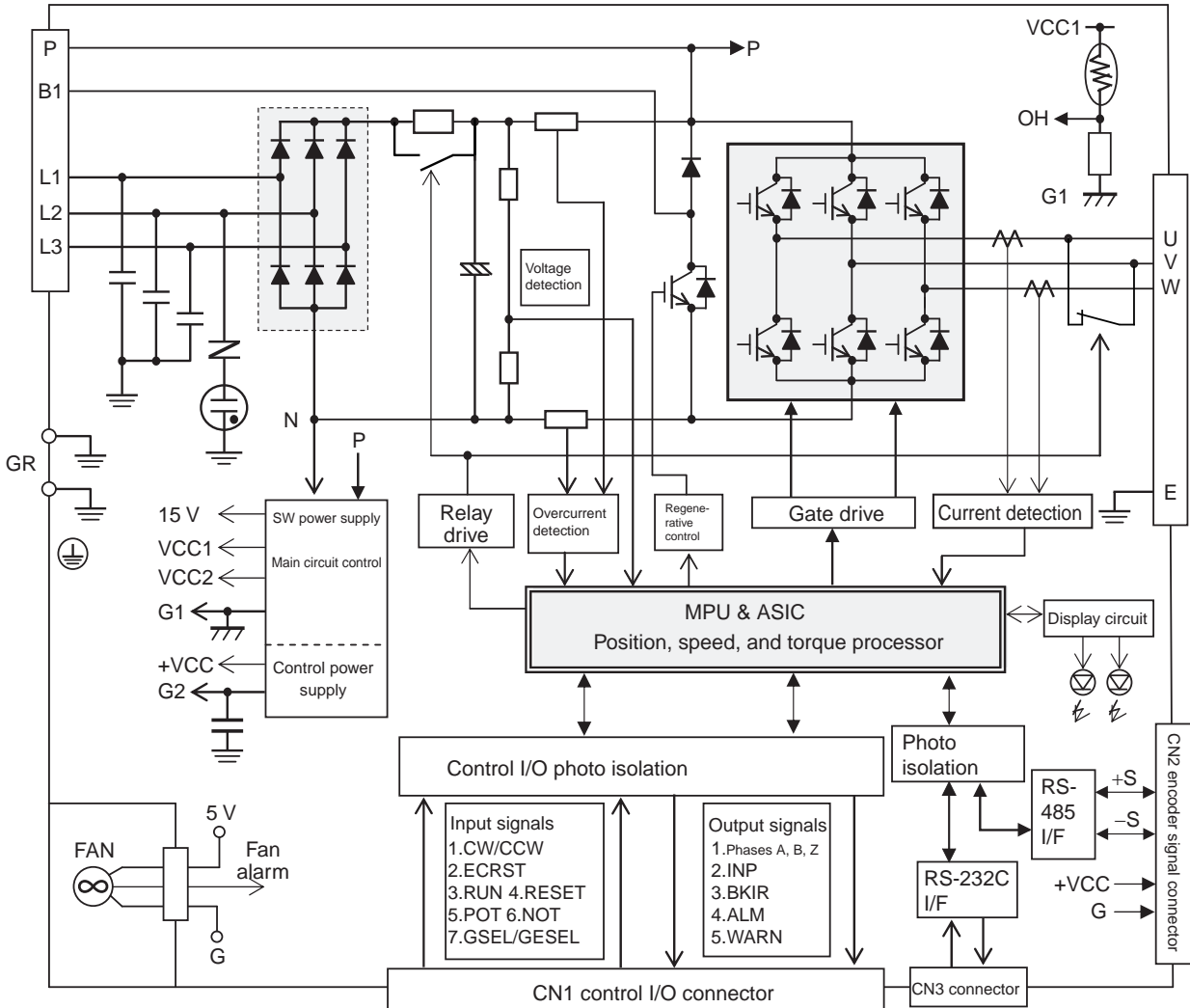



# 1-5 Applicable Standards

## EC Directives

EC Directive	Product	Applicable standards	Comments
Low Voltage Directive	AC Servo Drive	EN 50178	Safety requirements for electronic equipment for measurement, control, or laboratory use
	AC Servomotor	IEC 60034-1	Rotating electric machines
EMC Directive	AC Servo Drive and AC Servomotor	EN 55011 class A group1	Radio disturbance limits and measurement methods of industrial, scientific, and medical radio-frequency equipment
		EN 61000-6-2	Electromagnetic compatibility (EMC): Immunity standard for industrial environments

**Note** To conform to the EMC Directives, the Servomotor and Servo Drive must be installed under the conditions described in *4-3 Wiring Conforming to EMC Directives*.

## UL Standards

Standard	Product	Applicable standards	File number	Comments
UL Standard	AC Servo Drive	UL 508C	E179149	Power conversion equipment



# Chapter 2

## Standard Models and Dimensions

<b>2-1</b>	<b>Standard Models .....</b>	<b>2-1</b>
	Servo Drives .....	2-1
	Servomotors.....	2-1
	Parameter Unit.....	2-2
	Servo Drive-Servomotor Combinations .....	2-2
	Decelerators.....	2-4
	Accessories and Cables .....	2-8
<b>2-2</b>	<b>External and Mounted Dimensions .....</b>	<b>2-13</b>
	Servo Drives .....	2-13
	Servomotors.....	2-15
	Parameter Unit Dimensions .....	2-18
	Decelerator Dimensions.....	2-19
	External Regeneration Resistor Dimensions .....	2-27
	Reactor Dimensions.....	2-28
	DIN Rail Mounting Unit Dimensions.....	2-29

## 2-1 Standard Models

### Servo Drives

Specifications		Model
Single-phase 100 VAC	50 W	R7D-BPA5L
	100 W	R7D-BP01L
	200 W	R7D-BP02L
Single-phase/three-phase 200 VAC	50 W	R7D-BP01H
	100 W	
	400 W	R7D-BP04H
Single-phase 200 VAC	200 W	R7D-BP02HH
Three-phase 200 VAC	200 W	R7D-BP02H

### Servomotors

#### ■ 3,000-r/min Servomotors

Specifications			Model	
			Straight shaft	Straight shaft with key and tap
Without brake	100/200 V	50 W	R88M-G05030H	R88M-G05030H-S2
	100 V	100 W	R88M-G10030L	R88M-G10030L-S2
		200 W	R88M-G20030L	R88M-G20030L-S2
	200 V	100 W	R88M-G10030H	R88M-G10030H-S2
		200 W	R88M-G20030H	R88M-G20030H-S2
		400 W	R88M-G40030H	R88M-G40030H-S2
With brake	100/200 V	50 W	R88M-G05030H-B	R88M-G05030H-BS2
	100 V	100 W	R88M-G10030L-B	R88M-G10030L-BS2
		200 W	R88M-G20030L-B	R88M-G20030L-BS2
	200 V	100 W	R88M-G10030H-B	R88M-G10030H-BS2
		200 W	R88M-G20030H-B	R88M-G20030H-BS2
		400 W	R88M-G40030H-B	R88M-G40030H-BS2

**Note** Models with oil seals are also available.

■ 3,000-r/min Flat Servomotors

Specifications			Model	
			Straight shaft	Straight shaft with key and tap
Without brake	100 V	100W	R88M-GP10030L	R88M-GP10030L-S2
		200W	R88M-GP20030L	R88M-GP20030L-S2
	200 V	100W	R88M-GP10030H	R88M-GP10030H-S2
		200W	R88M-GP20030H	R88M-GP20030H-S2
		400W	R88M-GP40030H	R88M-GP40030H-S2
	With brake	100 V	100W	R88M-GP10030L-B
200W			R88M-GP20030L-B	R88M-GP20030L-BS2
200 V		100W	R88M-GP10030H-B	R88M-GP10030H-BS2
		200W	R88M-GP20030H-B	R88M-GP20030H-BS2
		400W	R88M-GP40030H-B	R88M-GP40030H-BS2

**Note** Models with oil seals are also available.

Parameter Unit

Specifications	Model
Parameter Unit	R88A-PR02G

Servo Drive-Servomotor Combinations

Only the Servomotor and Servo Drive combinations listed here can be used. Do not use other combinations.

■ Single-phase 100-VAC Combinations

3,000-r/min Servomotors

Rated output	Servo Drive	Servomotor	
	Pulse-string input	Without brake	With brake
50 W	R7D-BPA5L	R88M-G05030H-□	R88M-G05030H-B□
100 W	R7D-BP01L	R88M-G10030L-□	R88M-G10030L-B□
200 W	R7D-BP02L	R88M-G20030L-□	R88M-G20030L-B□

3,000-r/min Flat Servomotors

Rated output	Servo Drive	Servomotor	
	Pulse-string input	Without brake	With brake
100 W	R7D-BP01L	R88M-GP10030L-□	R88M-GP10030L-B□
200 W	R7D-BP02L	R88M-GP20030L-□	R88M-GP20030L-B□

■ Single-phase 200-VAC Combinations

3,000-r/min Servomotors

Rated output	Servo Drive	Servomotor	
	Pulse-string input	Without brake	With brake
50 W	R7D-BP01H	R88M-G05030H-□	R88M-G05030H-B□
100 W		R88M-G10030H-□	R88M-G10030H-B□
200 W	R7D-BP02HH	R88M-G20030H-□	R88M-G20030H-B□
400 W	R7D-BP04H	R88M-G40030H-□	R88M-G40030H-B□

3,000-r/min Flat Servomotors

Rated output	Servo Drive	Servomotor	
	Pulse-string input	Without brake	With brake
100 W	R7D-BP01H	R88M-GP10030H-□	R88M-GP10030H-B□
200 W	R7D-BP02HH	R88M-GP20030H-□	R88M-GP20030H-B□
400 W	R7D-BP04H	R88M-GP40030H-□	R88M-GP40030H-B□

■ Three-phase 200-VAC Combinations

3,000-r/min Servomotors

Rated output	Servo Drive	Servomotor	
	Pulse-string input	Without brake	With brake
50 W	R7D-BP01H	R88M-G05030H-□	R88M-G05030H-B□
100 W		R88M-G10030H-□	R88M-G10030H-B□
200 W	R7D-BP02H	R88M-G20030H-□	R88M-G20030H-B□
400 W	R7D-BP04H	R88M-G40030H-□	R88M-G40030H-B□

3,000-r/min Flat Servomotors

Rated output	Servo Drive	Servomotor	
	Pulse-string input	Without brake	With brake
100 W	R7D-BP01H	R88M-GP10030H-□	R88M-GP10030H-B□
200 W	R7D-BP02H	R88M-GP20030H-□	R88M-GP20030H-B□
400 W	R7D-BP04H	R88M-GP40030H-□	R88M-GP40030H-B□

# Decelerators

■ Backlash = 3' Max.

## Decelerators for Cylindrical Servomotors

Specifications		Model
Motor capacity	Gear ratio	
50 W	1/5	R88G-HPG11A05100B□
	1/9	R88G-HPG11A09050B□
	1/21	R88G-HPG14A21100B□
	1/33	R88G-HPG14A33050B□
	1/45	R88G-HPG14A45050B□
100 W	1/5	R88G-HPG11A05100B□
	1/11	R88G-HPG14A11100B□
	1/21	R88G-HPG14A21100B□
	1/33	R88G-HPG20A33100B□
	1/45	R88G-HPG20A45100B□
200 W	1/5	R88G-HPG14A05200B□
	1/11	R88G-HPG14A11200B□
	1/21	R88G-HPG20A21200B□
	1/33	R88G-HPG20A33200B□
	1/45	R88G-HPG20A45200B□
400 W	1/5	R88G-HPG14A50400B□
	1/11	R88G-HPG20A11400B□
	1/21	R88G-HPG20A21400B□
	1/33	R88G-HPG32A33400B□
	1/45	R88G-HPG32A45400B□

**Note 1.** The standard models have a straight shaft.

**Note 2.** A model with a key and tap is indicated by adding "J" to the end of the model number (the suffix shown in the box).  
Example: R88G-HPG11A05100BJ

**Decelerator for Flat Servomotors**

Specifications		Model
Motor capacity	Gear ratio	
100 W	1/5	R88G-HPG11A05100PB□
	1/11	R88G-HPG14A11100PB□
	1/21	R88G-HPG14A21100PB□
	1/33	R88G-HPG20A33100PB□
	1/45	R88G-HPG20A45100PB□
200 W	1/5	R88G-HPG14A05200PB□
	1/11	R88G-HPG20A11200PB□
	1/21	R88G-HPG20A21200PB□
	1/33	R88G-HPG20A33200PB□
	1/45	R88G-HPG20A45200PB□
400 W	1/5	R88G-HPG20A05400PB□
	1/11	R88G-HPG20A11400PB□
	1/21	R88G-HPG20A21400PB□
	1/33	R88G-HPG32A33400PB□
	1/45	R88G-HPG32A45400PB□

**Note 1.** The standard models have a straight shaft.

**Note 2.** A model with a key and tap is indicated by adding “J” to the end of the model number (the suffix shown in the box).

Example: R88G-HPG11A05100PBJ



■ Backlash = 15' Max.

**Decelerators for Cylindrical Servomotors**

Specifications		Model
Motor capacity	Gear ratio	
50 W	1/5	R88G-VRSF05B100CJ
	1/9	R88G-VRSF09B100CJ
	1/15	R88G-VRSF15B100CJ
	1/25	R88G-VRSF25B100CJ
100 W	1/5	R88G-VRSF05B100CJ
	1/9	R88G-VRSF09B100CJ
	1/15	R88G-VRSF15B100CJ
	1/25	R88G-VRSF25B100CJ
200 W	1/5	R88G-VRSF05B200CJ
	1/9	R88G-VRSF09C200CJ
	1/15	R88G-VRSF15C200CJ
	1/25	R88G-VRSF25C200CJ
400 W	1/5	R88G-VRSF05C400CJ
	1/9	R88G-VRSF09C400CJ
	1/15	R88G-VRSF15C400CJ
	1/25	R88G-VRSF25C400CJ

**Note 1.** The standard models have a straight shaft with a key.

**Note 2.** The backlash is the value when a load of ±5% of the allowable output torque is applied to the output shaft.

**Decelerators for Flat Servomotors**

Specifications		Model
Motor capacity	Gear ratio	
100 W	1/5	R88G-VRSF05B100PCJ
	1/9	R88G-VRSF09B100PCJ
	1/15	R88G-VRSF15B100PCJ
	1/25	R88G-VRSF25B100PCJ
200 W	1/5	R88G-VRSF05B200PCJ
	1/9	R88G-VRSF09C200PCJ
	1/15	R88G-VRSF15C200PCJ
	1/25	R88G-VRSF25C200PCJ
400 W	1/5	R88G-VRSF05C400PCJ
	1/9	R88G-VRSF09C400PCJ
	1/15	R88G-VRSF15C400PCJ
	1/25	R88G-VRSF25C400PCJ

**Note 1.** The standard models have a straight shaft with a key.

**Note 2.** The backlash is the value when a load of  $\pm 5\%$  of the allowable output torque is applied to the output shaft.

## Accessories and Cables

### ■ Encoder Cables (for CN2)

Specifications		Model
Standard Cables (connectors attached)	3 m	R88A-CRGB003C
	5 m	R88A-CRGB005C
	10 m	R88A-CRGB010C
	15 m	R88A-CRGB015C
	20 m	R88A-CRGB020C
Robot Cables (connectors attached)	3 m	R88A-CRGB003CR
	5 m	R88A-CRGB005CR
	10 m	R88A-CRGB010CR
	15 m	R88A-CRGB015CR
	20 m	R88A-CRGB020CR

### ■ Servomotor Power Cables (for CNB)

Specifications		Model
Standard Cables (connectors attached)	3 m	R7A-CAB003S
	5 m	R7A-CAB005S
	10 m	R7A-CAB010S
	15 m	R7A-CAB015S
	20 m	R7A-CAB020S
Robot Cables (connectors attached)	3 m	R7A-CAB003SR
	5 m	R7A-CAB005SR
	10 m	R7A-CAB010SR
	15 m	R7A-CAB015SR
	20 m	R7A-CAB020SR

### ■ Brake Cables

Specifications		Model
Standard Cables	3 m	R88A-CAGA003B
	5 m	R88A-CAGA005B
	10 m	R88A-CAGA010B
	15 m	R88A-CAGA015B
	20 m	R88A-CAGA020B
Robot Cables	3 m	R88A-CAGA003BR
	5 m	R88A-CAGA005BR
	10 m	R88A-CAGA010BR
	15 m	R88A-CAGA015BR
	20 m	R88A-CAGA020BR

■ Power Supply Cables

Specifications		Model
Power Supply Input Cable for Single-Phase Power (connectors attached)	2 m	R7A-CLB002S2
Power Supply Input Cable for Three-Phase Power (connectors attached)	2 m	R7A-CLB002S3
External Regeneration Resistor Connection Cable	2 m	R7A-CLB002RG

■ Personal Computer Monitor Cable

Specifications		Model
Personal Computer Monitor Cable	2 m	R88A-CCG002P2

■ Connectors

Specifications	Model
Main Circuit Connector (CNA)	R7A-CNB01P
Servomotor Connector (CNB)	R7A-CNB01A
Control I/O Connector (CN1)	R88A-CNW01C
Encoder Input Connector (CN2)	R88A-CNW01R
Servomotor Connector for Encoder Cable	R88A-CNG02R
Servomotor Connector for Servomotor Power Cable	R88A-CNG01A
Brake Cable Connector	R88A-CNG01B

### ■ Servo Relay Units (for CN1)

Specifications		Model
Servo Relay Units	For CJ1W-NC133/-NC113 For CS1W-NC133/-NC113 For C200HW-NC113	XW2B-20J6-1B
	For CJ1W-NC233/-NC433/-NC213/-NC413 For CS1W-NC233/-NC433/-NC213/-NC413 For C200HW-NC213/-NC413	XW2B-40J6-2B
	For CJ1M-CPU21 For CJ1M-CPU22 For CJ1M-CPU23	XW2B-20J6-8A XW2B-40J6-9A (for 2 axes)
	For FQM1-MMP22	XW2B-80J7-12A
	For CQM1H-PLB21 For CQM1-CPU43-V1	XW2B-20J6-3B

### ■ Servo Relay Unit Cables for Servo Drives

Specifications		Model	
Servo Drive Cables	For Position Control Unit/CQM1 (XW2B-□J6-□B)	1 m	XW2Z-100J-B29
		2 m	XW2Z-200J-B29
	For CJ1M (XW2B-20J6-8A/XW2B-40J6-9A)	1 m	XW2Z-100J-B32
		2 m	XW2Z-200J-B32
	For FQM1-MMP22 (XW2B-80J7-12A)	1 m	XW2Z-100J-B30
		2 m	XW2Z-200J-B30

■ Servo Relay Unit Cables for Position Control Units

Specifications		Model		
Position Control Unit Cables	For CJ1W-NC133	0.5 m	XW2Z-050J-A18	
		1 m	XW2Z-100J-A18	
	For CJ1W-NC233/-NC433	0.5 m	XW2Z-050J-A19	
		1 m	XW2Z-100J-A19	
	For CS1W-NC133	0.5 m	XW2Z-050J-A10	
		1 m	XW2Z-100J-A10	
	For CS1W-NC233/-NC433	0.5 m	XW2Z-050J-A11	
		1 m	XW2Z-100J-A11	
	For CJ1W-NC113	0.5 m	XW2Z-050J-A14	
		1 m	XW2Z-100J-A14	
	For CJ1W-NC213/-NC413	0.5 m	XW2Z-050J-A15	
		1 m	XW2Z-100J-A15	
	For CS1W-NC113 For C200HW-NC113	0.5 m	XW2Z-050J-A6	
		1 m	XW2Z-100J-A6	
	For CS1W-NC213/-NC413 For C200HW-NC213/-NC413	0.5 m	XW2Z-050J-A7	
		1 m	XW2Z-100J-A7	
	For CJ1M-CPU21 For CJ1M-CPU22 For CJ1M-CPU23	0.5 m	XW2Z-050J-A33	
		1 m	XW2Z-100J-A33	
	For FQM1-MMP22	General-purpose I/O Cables	0.5 m	XW2Z-050J-A28
			1 m	XW2Z-100J-A28
2 m			XW2Z-200J-A28	
Special I/O Cables		0.5 m	XW2Z-050J-A30	
		1 m	XW2Z-100J-A30	
		2 m	XW2Z-200J-A30	
For CQM1H-PLB21 For CQM1-CPU43-V1	0.5 m	XW2Z-050J-A3		
	1 m	XW2Z-100J-A3		

■ Control Cables (for CN1)

Specifications		Model
Connector-Terminal Block Cables	1 m	XW2Z-100J-B28
	2 m	XW2Z-200J-B28
General-purpose Control Cables	1 m	R7A-CPB001S
	2 m	R7A-CPB002S

### ■ Connector-Terminal Block Conversion Units

Specifications	Model
M3 screws type	XW2B-34G4
M3.5 screws type	XW2B-34G5
M3 screws type	XW2D-34G6

### ■ External Regeneration Resistors

Specifications	Model
Regeneration capacity: 70 W, 47 $\Omega$	R88A-RR22047S
Regeneration capacity: 20 W, 100 $\Omega$	R88A-RR080100S
Regeneration capacity: 20 W, 50 $\Omega$	R88A-RR08050S

### ■ Reactors

Specifications	Applicable Servo Drive	Model
Single-phase 100 V	R7D-BPA5L	3G3AX-DL2002
	R7D-BP01L	3G3AX-DL2004
	R7D-BP02L	3G3AX-DL2007
Single-phase 200 V	R7D-BP01H	3G3AX-DL2004
	R7D-BP02HH	3G3AX-DL2004
	R7D-BP04H	3G3AX-DL2007
Three-phase 200 V	R7D-BP01H	3G3AX-AL2025
	R7D-BP02H	3G3AX-AL2025
	R7D-BP04H	3G3AX-AL2025

### ■ DIN Rail Mounting Unit

Specifications	Model
DIN Rail Mounting Unit	R7A-DIN01B

# 2-2 External and Mounted Dimensions

2

## Servo Drives

- R7D-BPA5L/-BP01L/-BP01H/-BP02H (50 W/100 W/200 W)

Standard Models and Dimensions

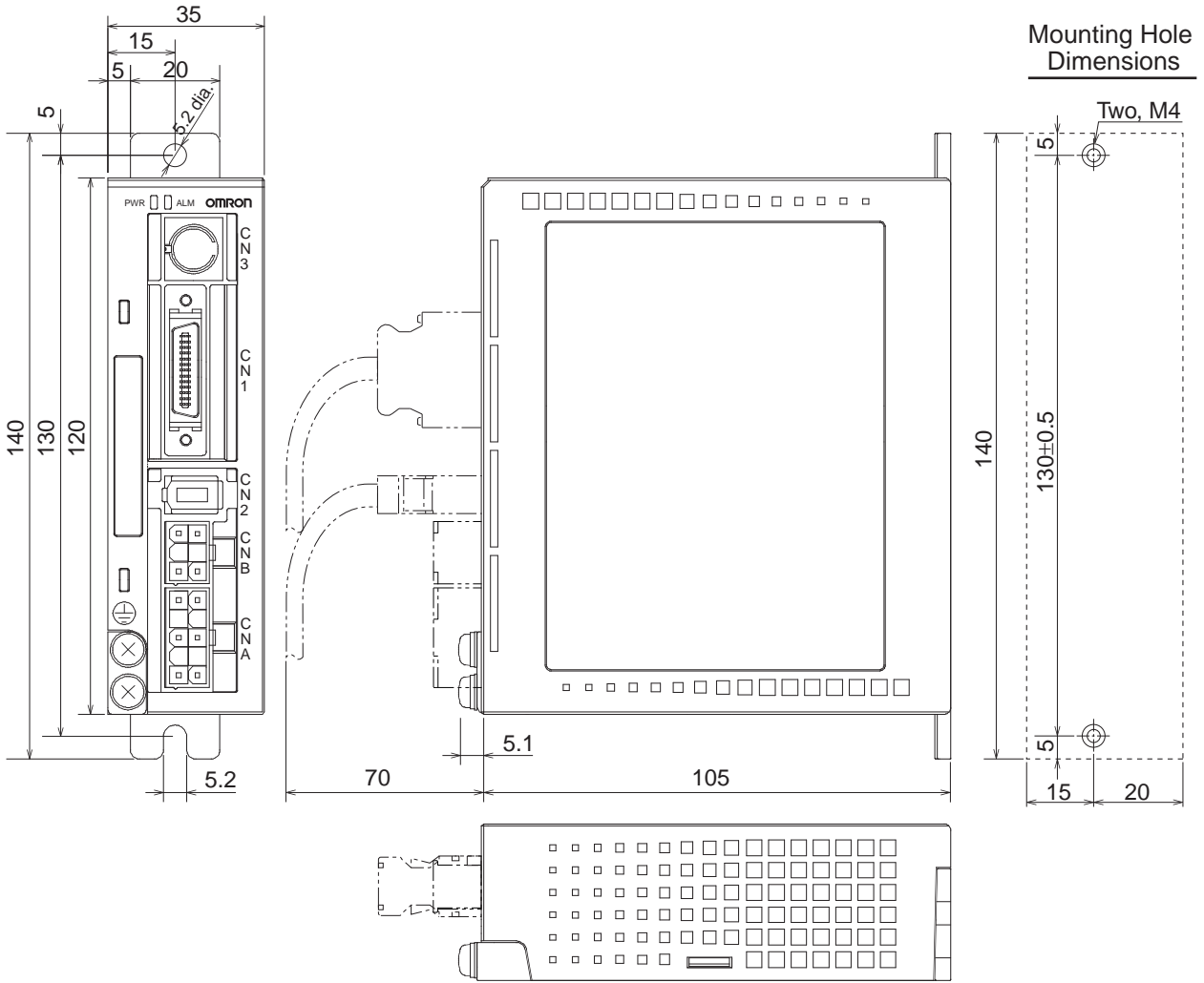



■ R7D-BP02L/-BP02HH/-BP04H (200 W/400 W)

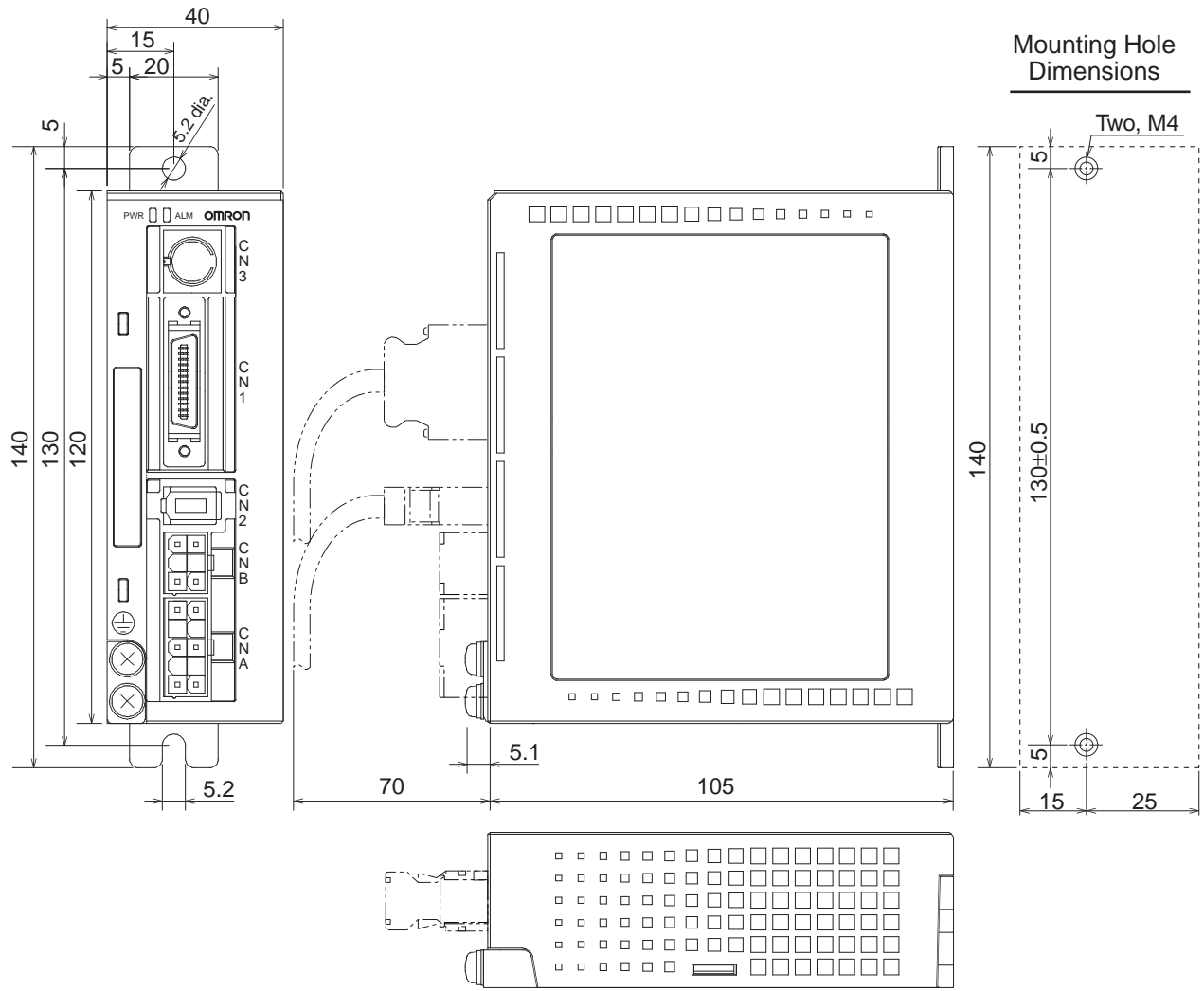

Servomotors

■ 3,000-r/min 50-/100-W Servomotors

R88M-G05030H(-S2)/-G10030L(-S2)/-G10030H(-S2)  
 /-G05030H-B(S2)/-G10030L-B(S2)/-G10030H-B(S2)

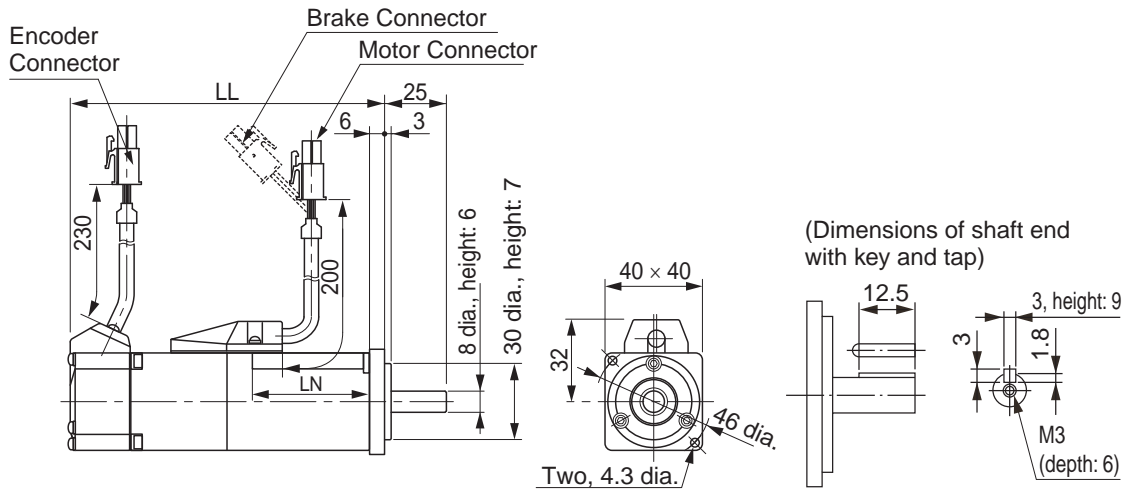

Model	LL	LN
	(mm)	(mm)
R88M-G05030H	72	26.5
R88M-G05030H-B <sup>*1</sup>	102	26.5
R88M-G10030□ <sup>*2</sup>	92	46.5
R88M-G10030□-B <sup>*1, *2</sup>	122	46.5

\*1. This is the model number for the Servomotor with a brake.  
 \*2. Put "L" or "H" in the place indicated by the box.

**Note** The standard models have a straight shaft. A model with a key and tap is indicated by adding "S2" to the end of the model number.

■ 3,000-r/min 200-/400-W Servomotors

R88M-G20030L(-S2)/-G20030H(-S2)/-G40030H(-S2)  
 /-G20030L-B(S2)/-G20030H-B(S2)/-G40030H-B(S2)

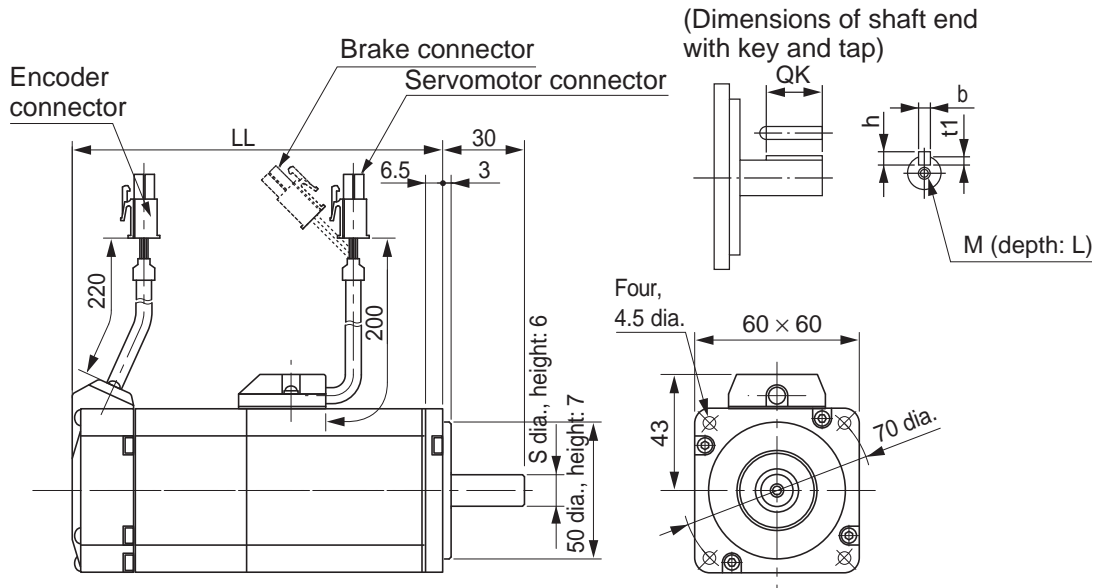

Model	LL	S	Dimensions for models with key and tap <sup>*3</sup>					
			QK	b	h	t1	M	L
			(mm)		(mm)	(mm)		(mm)
R88M-G20030□ <sup>*1</sup>	79.5	11	18	4h9	4	2.5	M4	8
R88M-G20030□-B <sup>*1,*2</sup>	116	11	18	4h9	4	2.5	M4	8
R88M-G40030H	99	14	22.5	5h9	5	3	M5	10
R88M-G40030H-B <sup>*2</sup>	135.5	14	22.5	5h9	5	3	M5	10

\*1. Put "L" or "H" in the place indicated by the box.

\*2. This is the model number for the Servomotor with a brake.

\*3. A model with a key and tap is indicated by adding "S2" to the end of the model number.

**Note** The standard models have a straight shaft.

■ 3,000-r/min 100-/200-/400-W Flat Servomotors

R88M-GP10030L(-S2)/-GP10030H(-S2)/-GP20030L(-S2)/-GP20030H(-S2)  
/-GP40030H(-S2)

R88M-GP10030L-B(S2)/-GP10030H-B(S2)/-GP20030L-B(S2)/-GP20030H-B(S2)  
/-GP40030H-B(S2)

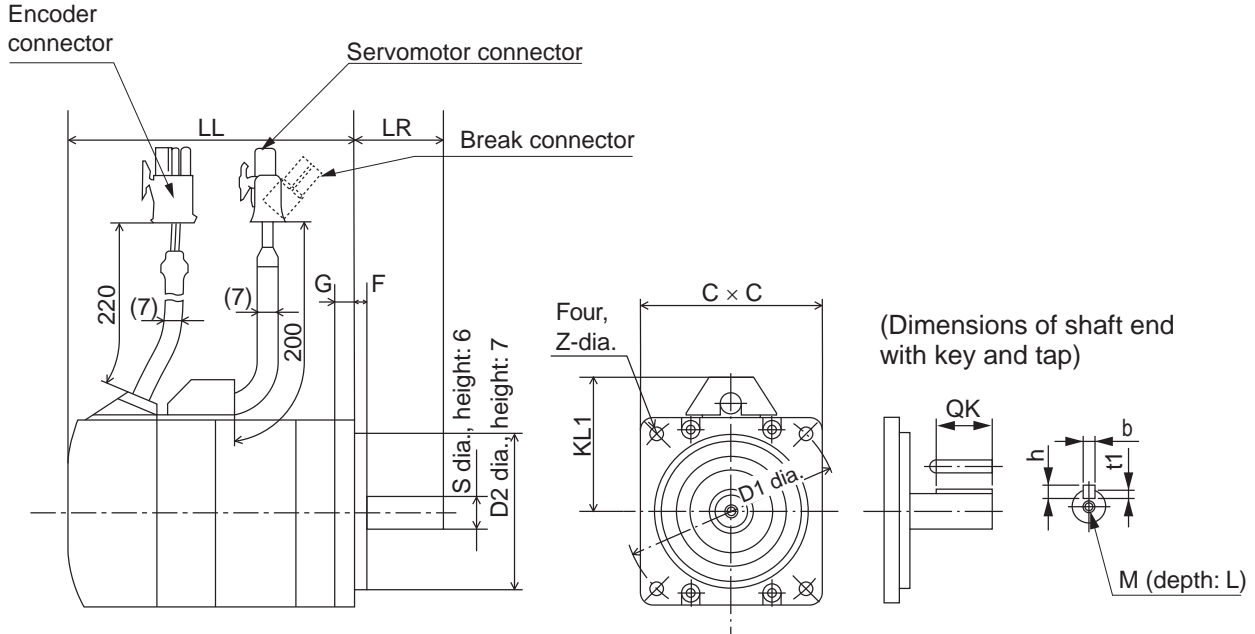

Model	LL	LR	S	D1	D2	C	F	G
	(mm)	(mm)	(mm)	(mm)	(mm)	(mm)	(mm)	(mm)
R88M-GP10030□ <sup>*1</sup>	60.5	25	8	70	50	60	3	7
R88M-GP10030□-B <sup>*1,*2</sup>	84.5	25	8	70	50	60	3	7
R88M-GP20030□ <sup>*1</sup>	67.5	30	11	90	70	80	5	8
R88M-GP20030□-B <sup>*1,*2</sup>	100	30	11	90	70	80	5	8
R88M-GP40030H	82.5	30	14	90	70	80	5	8
R88M-GP40030H-B <sup>*2</sup>	115	30	14	90	70	80	5	8

Model	KL1	Z	Dimensions for models with key and tap <sup>*3</sup>					
			QK	b	h	t1	M	L
			(mm)	(mm)	(mm)	(mm)	(mm)	(mm)
R88M-GP10030□ <sup>*1</sup>	43	4.5	12.5	3h9	3	1.8	M3	6
R88M-GP10030□-B <sup>*1,*2</sup>	43	4.5	12.5	3h9	3	1.8	M3	6
R88M-GP20030□ <sup>*1</sup>	53	5.5	18	4h9	4	2.5	M4	8
R88M-GP20030□-B <sup>*1,*2</sup>	53	5.5	18	4h9	4	2.5	M4	8
R88M-GP40030H	53	5.5	22.5	5h9	5	3.0	M5	10
R88M-GP40030H-B <sup>*2</sup>	53	5.5	22.5	5h9	5	3.0	M5	10

\*1. Put "L" or "H" in the place indicated by the box.

\*2. This is the model number for the Servomotor with a brake.

\*3. A model with a key and tap is indicated by adding "S2" to the end of the model number.

**Note** The standard models have a straight shaft.

Parameter Unit Dimensions

■ R88A-PR02G

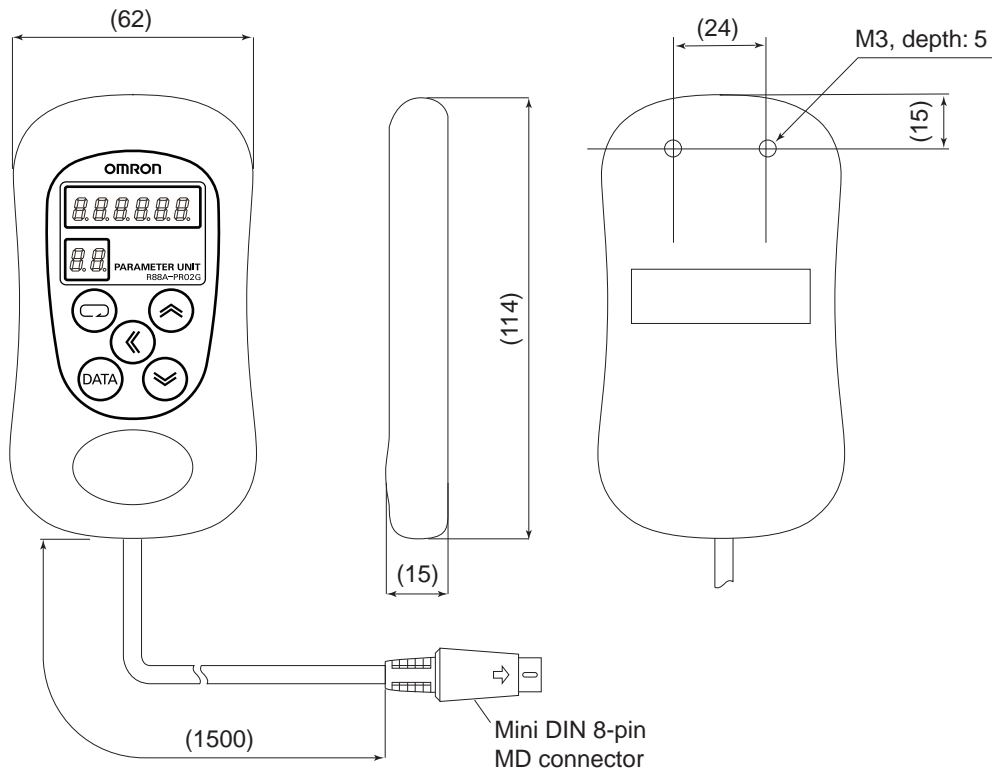

## Decelerator Dimensions

■ Backlash = 3' Max.

### Decelerators for Cylindrical Servomotors

Model (R88G-)			Dimensions (mm)								
			LM	LR	C1	C2	D1	D2	D3	D4	D5
50 W	1/5	HPG11A05100B□	39.5	42	40	40 × 40	46	46	40.0	39.5	29
	1/9	HPG11A09050B□	39.5	42	40	40 × 40	46	46	40.0	39.5	29
	1/21	HPG14A21100B□	64.0	58	60	60 × 60	70	46	56.0	55.5	40
	1/33	HPG14A33050B□	64.0	58	60	60 × 60	70	46	56.0	55.5	40
	1/45	HPG14A45050B□	64.0	58	60	60 × 60	70	46	56.0	55.5	40
100 W	1/5	HPG11A05100B□	39.5	42	40	40 × 40	46	46	40.0	39.5	29
	1/11	HPG14A11100B□	64.0	58	60	60 × 60	70	46	56.0	55.5	40
	1/21	HPG14A21100B□	64.0	58	60	60 × 60	70	46	56.0	55.5	40
	1/33	HPG20A33100B□	66.5	80	90	55 dia.	105	46	85.0	84.0	59
	1/45	HPG20A45100B□	66.5	80	90	55 dia.	105	46	85.0	84.0	59
200 W	1/5	HPG14A05200B□	64.0	58	60	60 × 60	70	70	56.0	55.5	40
	1/11	HPG14A11200B□	64.0	58	60	60 × 60	70	70	56.0	55.5	40
	1/21	HPG20A21200B□	71.0	80	90	89 dia.	105	70	85.0	84.0	59
	1/33	HPG20A33200B□	71.0	80	90	89 dia.	105	70	85.0	84.0	59
	1/45	HPG20A45200B□	71.0	80	90	89 dia.	105	70	85.0	84.0	59
400 W	1/5	HPG14A05400B□	64.0	58	60	60 × 60	70	70	56.0	55.5	40
	1/11	HPG20A11400B□	71.0	80	90	89 dia.	105	70	85.0	84.0	59
	1/21	HPG20A21400B□	71.0	80	90	89 dia.	105	70	85.0	84.0	59
	1/33	HPG32A33400B□	104.0	133	120	122 dia.	135	70	115.0	114.0	84
	1/45	HPG32A45400B□	104.0	133	120	122 dia.	135	70	115.0	114.0	84

**Note** The standard models have a straight shaft. A model with a key and tap is indicated by adding "J" to the end of the model number (the suffix shown in the box).

### Outline Drawings

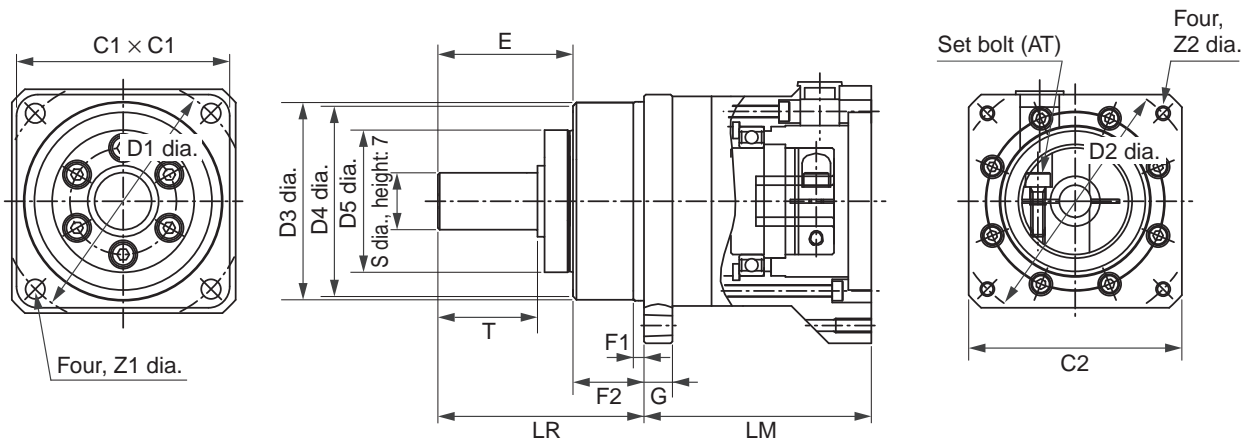

Dimensions (mm)									Key and tap dimensions (mm)						Weight (kg)
E	F1	F2	G	S	T	Z1	Z2	AT*1	QK	b	h	t1	M	L	
27	2.2	15	5	8	20	3.4	M4	M3	15	3	3	1.8	M3	6	0.29
27	2.2	15	5	8	20	3.4	M4	M3	15	3	3	1.8	M3	6	0.29
37	2.5	21	8	16	28	5.5	M4	M3	25	5	5	3	M4	8	1.04
37	2.5	21	8	16	28	5.5	M4	M3	25	5	5	3	M4	8	1.04
37	2.5	21	8	16	28	5.5	M4	M3	25	5	5	3	M4	8	1.04
27	2.2	15	5	8	20	3.4	M4	M3	15	3	3	1.8	M3	6	0.29
37	2.5	21	8	16	28	5.5	M4	M3	25	5	5	3	M4	8	1.04
37	2.5	21	8	16	28	5.5	M4	M3	25	5	5	3	M4	8	1.04
53	7.5	27	10	25	42	9.0	M4	M4	36	8	7	4.0	M6	12	2.4
53	7.5	27	10	25	42	9.0	M4	M4	36	8	7	4.0	M6	12	2.4
37	2.5	21	8	16	28	5.5	M4	M3	25	5	5	3	M4	8	1.02
37	2.5	21	8	16	28	5.5	M4	M3	25	5	5	3	M4	8	1.09
53	7.5	27	10	25	42	9.0	M4	M4	36	8	7	4.0	M6	12	2.9
53	7.5	27	10	25	42	9.0	M4	M4	36	8	7	4.0	M6	12	2.9
53	7.5	27	10	25	42	9.0	M4	M4	36	8	7	4.0	M6	12	2.9
37	2.5	21	8	16	28	5.5	M4	M3	25	5	5	3	M4	8	1.09
53	7.5	27	10	25	42	9.0	M4	M4	36	8	7	4.0	M6	12	2.9
53	7.5	27	10	25	42	9.0	M4	M4	36	8	7	4.0	M6	12	2.9
98	12.5	35	13	40	82	11.0	M4	M4	70	12	8	5.0	M10	20	7.5
98	12.5	35	13	40	82	11.0	M4	M4	70	12	8	5.0	M10	20	7.5

\*1. This is the set bolt.

Key and Tap Dimensions

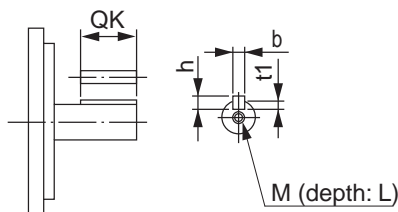

## 2-2 External and Mounted Dimensions

### Decelerators for Flat Servomotors

Model (R88G-)			Dimensions (mm)								
			LM	LR	C1	C2	D1	D2	D3	D4	D5
100 W	1/5	HPG11A05100PB□	39.5	42	40	60 × 60	46	70	40.0	39.5	29
	1/11	HPG14A11100PB□	64.0	58	60	60 × 60	70	70	56.0	55.5	40
	1/21	HPG14A21100PB□	64.0	58	60	60 × 60	70	70	56.0	55.5	40
	1/33	HPG20A33100PB□	71.0	80	90	89 dia.	105	70	85.0	84.0	59
	1/45	HPG20A45100PB□	71.0	80	90	89 dia.	105	70	85.0	84.0	59
200 W	1/5	HPG14A05200PB□	65.0	58	60	80 × 80	70	90	56.0	55.5	40
	1/11	HPG20A11200PB□	78.0	80	90	80 × 80	105	90	85.0	84.0	59
	1/21	HPG20A21200PB□	78.0	80	90	80 × 80	105	90	85.0	84.0	59
	1/33	HPG20A33200PB□	78.0	80	90	80 × 80	105	90	85.0	84.0	59
	1/45	HPG20A45200PB□	78.0	80	90	80 × 80	105	90	85.0	84.0	59
400 W	1/5	HPG20A05400PB□	78.0	80	90	80 × 80	105	90	85.0	84.0	59
	1/11	HPG20A11400PB□	78.0	80	90	80 × 80	105	90	85.0	84.0	59
	1/21	HPG20A21400PB□	78.0	80	90	80 × 80	105	90	85.0	84.0	59
	1/33	HPG32A33400PB□	104.0	133	120	122 dia.	135	90	115.0	114.0	84
	1/45	HPG32A45400PB□	104.0	133	120	122 dia.	135	90	115.0	114.0	84

**Note** The standard models have a straight shaft. A model with a key and tap is indicated by adding "J" to the end of the model number.

### Outline Drawings

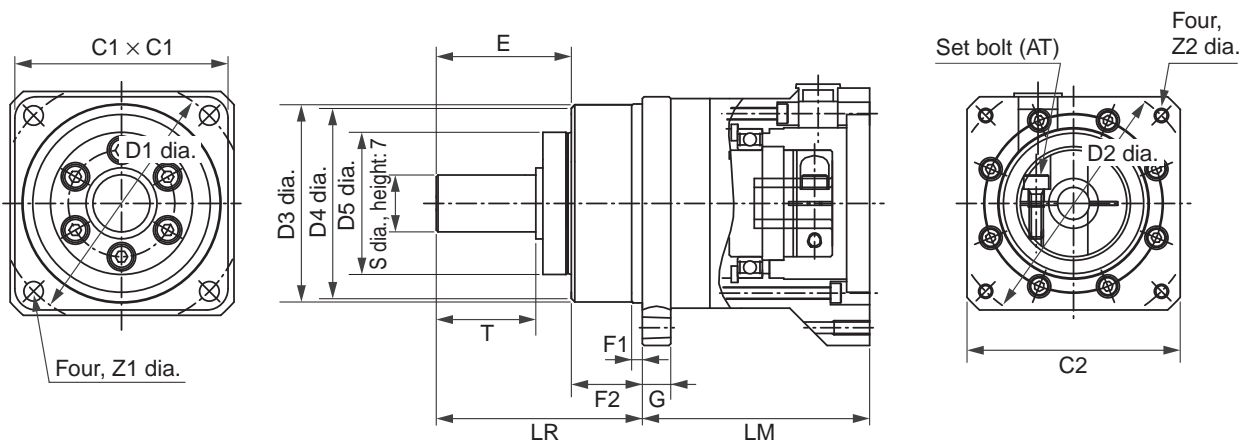



Dimensions (mm)									Key and tap dimensions (mm)					Weight (kg)	
E	F1	F2	G	S	T	Z1	Z2	AT*1	QK	b	h	t1	M		L
27	2.2	15	5	8	20	3.4	M4	M3	15	3	3	1.8	M3	6	0.34
37	2.5	21	8	16	28	5.5	M4	M3	25	5	5	3.0	M4	8	1.04
37	2.5	21	8	16	28	5.5	M4	M3	25	5	5	3.0	M4	8	1.04
53	7.5	27	10	25	42	9.0	M4	M3	36	8	7	4.0	M6	12	2.9
53	7.5	27	10	25	42	9.0	M4	M3	36	8	7	4.0	M6	12	2.9
37	2.5	21	8	16	28	5.5	M4	M4	25	5	5	3.0	M4	8	0.99
53	7.5	27	10	25	42	9.0	M5	M4	36	8	7	4.0	M6	12	3.1
53	7.5	27	10	25	42	9.0	M5	M4	36	8	7	4.0	M6	12	3.1
53	7.5	27	10	25	42	9.0	M5	M4	36	8	7	4.0	M6	12	3.1
53	7.5	27	10	25	42	9.0	M5	M4	36	8	7	4.0	M6	12	3.1
53	7.5	27	10	25	42	9.0	M5	M4	36	8	7	4.0	M6	12	3.1
53	7.5	27	10	25	42	9.0	M5	M4	36	8	7	4.0	M6	12	3.1
53	7.5	27	10	25	42	9.0	M5	M4	36	8	7	4.0	M6	12	3.1
98	12.5	35	13	40	82	11.0	M5	M6	70	12	8	5.0	M10	20	7.8
98	12.5	35	13	40	82	11.0	M5	M6	70	12	8	5.0	M10	20	7.8

\*1. This is the set bolt.

Key and Tap Dimensions

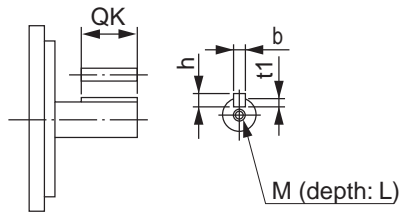

## 2-2 External and Mounted Dimensions

■ Backlash = 15' Max.

### Decelerators for Cylindrical Servomotors

Model (R88G-)			Dimensions (mm)										
			LM	LR	C1	C2	D1	D2	D3	D4	E3	F	G
50 W	1/5	VRSF05B100CJ	67.5	32	40	52	46	60	50	45	10	3	6
	1/9	VRSF09B100CJ	67.5	32	40	52	46	60	50	45	10	3	6
	1/15	VRSF15B100CJ	78.0	32	40	52	46	60	50	45	10	3	6
	1/25	VRSF25B100CJ	78.0	32	40	52	46	60	50	45	10	3	6
100 W	1/5	VRSF05B100CJ	67.5	32	40	52	46	60	50	45	10	3	6
	1/9	VRSF09B100CJ	67.5	32	40	52	46	60	50	45	10	3	6
	1/15	VRSF15B100CJ	78.0	32	40	52	46	60	50	45	10	3	6
	1/25	VRSF25B100CJ	78.0	32	40	52	46	60	50	45	10	3	6
200 W	1/5	VRSF05B200CJ	72.5	32	60	52	70	60	50	45	10	3	10
	1/9	VRSF09C200CJ	89.5	50	60	78	70	90	70	62	17	3	8
	1/15	VRSF15C200CJ	100.0	50	60	78	70	90	70	62	17	3	8
	1/25	VRSF25C200CJ	100.0	50	60	78	70	90	70	62	17	3	8
400 W	1/5	VRSF05C400CJ	89.5	50	60	78	70	90	70	62	17	3	8
	1/9	VRSF09C400CJ	89.5	50	60	78	70	90	70	62	17	3	8
	1/15	VRSF15C400CJ	100.0	50	60	78	70	90	70	62	17	3	8
	1/25	VRSF25C400CJ	100.0	50	60	78	70	90	70	62	17	3	8

**Note** The standard models have a straight shaft with a key.

### Outline Drawings

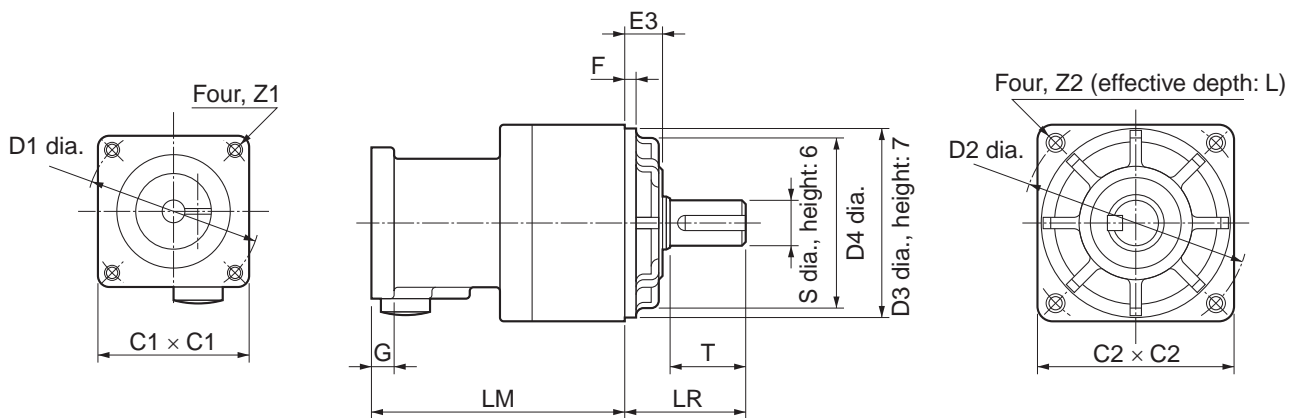

Dimensions (mm)						Key dimensions (mm)				Weight (kg)	Model (R88G-)		
S	T	Z1	Z2	AT*1	L	QK	b	h	t1				
12	20	M4	M5	M3	12	16	4	4	2.5	0.55	VRSF05B100CJ	1/5	50 W
12	20	M4	M5	M3	12	16	4	4	2.5	0.55	VRSF09B100CJ	1/9	
12	20	M4	M5	M3	12	16	4	4	2.5	0.70	VRSF15B100CJ	1/15	
12	20	M4	M5	M3	12	16	4	4	2.5	0.70	VRSF25B100CJ	1/25	
12	20	M4	M5	M3	12	16	4	4	2.5	0.55	VRSF05B100CJ	1/5	100 W
12	20	M4	M5	M3	12	16	4	4	2.5	0.55	VRSF09B100CJ	1/9	
12	20	M4	M5	M3	12	16	4	4	2.5	0.70	VRSF15B100CJ	1/15	
12	20	M4	M5	M4	12	16	4	4	2.5	0.72	VRSF05B200CJ	1/5	200 W
19	30	M4	M6	M4	20	22	6	6	3.5	1.70	VRSF09C200CJ	1/9	
19	30	M4	M6	M4	20	22	6	6	3.5	2.10	VRSF15C200CJ	1/15	
19	30	M4	M6	M4	20	22	6	6	3.5	2.10	VRSF25C200CJ	1/25	400 W
19	30	M4	M6	M4	20	22	6	6	3.5	1.70	VRSF05C400CJ	1/5	
19	30	M4	M6	M4	20	22	6	6	3.5	1.70	VRSF09C400CJ	1/9	
19	30	M4	M6	M4	20	22	6	6	3.5	2.10	VRSF15C400CJ	1/15	
19	30	M4	M6	M4	20	22	6	6	3.5	2.10	VRSF25C400CJ	1/25	

\*1. This is the set bolt.

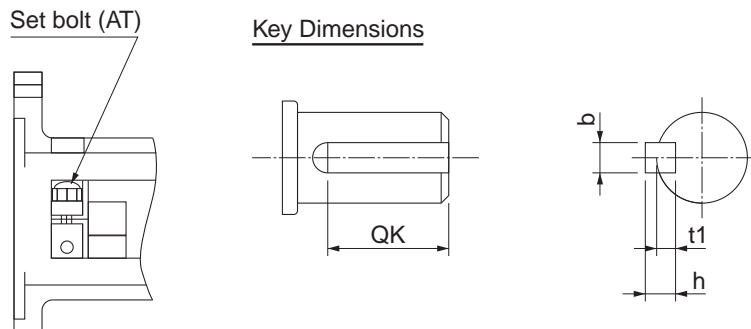

## 2-2 External and Mounted Dimensions

### Decelerators for Flat Servomotors

Model (R88G-)			Dimensions (mm)										
			LM	LR	C1	C2	D1	D2	D3	D4	E3	F	G
100 W	1/5	VRSF05B100PCJ	67.5	32	60	52	70	60	50	45	10	3	8
	1/9	VRSF09B100PCJ	67.5	32	60	52	70	60	50	45	10	3	8
	1/15	VRSF15B100PCJ	78.0	32	60	52	70	60	50	45	10	3	8
	1/25	VRSF25B100PCJ	78.0	32	60	52	70	60	50	45	10	3	8
200 W	1/5	VRSF05B200PCJ	72.5	32	80	52	90	60	50	45	10	3	12
	1/9	VRSF09C200PCJ	89.5	50	80	78	90	90	70	62	17	3	12
	1/15	VRSF15C200PCJ	100.0	50	80	78	90	90	70	62	17	3	12
	1/25	VRSF25C200PCJ	100.0	50	80	78	90	90	70	62	17	3	12
400 W	1/5	VRSF05C400PCJ	89.5	50	80	78	90	90	70	62	17	3	12
	1/9	VRSF09C400PCJ	89.5	50	80	78	90	90	70	62	17	3	12
	1/15	VRSF15C400PCJ	100.0	50	80	78	90	90	70	62	17	3	12
	1/25	VRSF25C400PCJ	100.0	50	80	78	90	90	70	62	17	3	12

**Note** The standard models have a straight shaft with a key.

### Outline Drawings

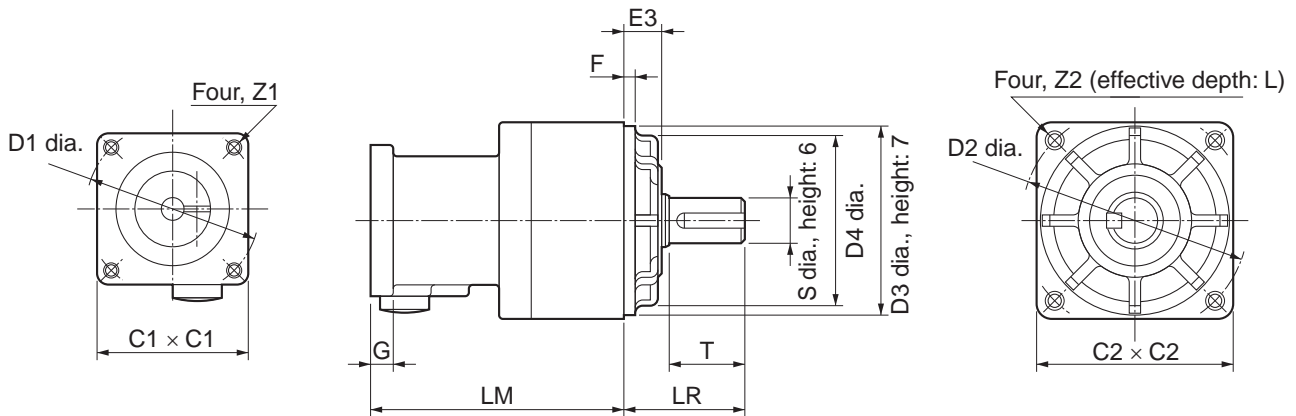

## 2-2 External and Mounted Dimensions

Dimensions (mm)						Key dimensions (mm)				Weight (kg)	Model (R88G-)		
S	T	Z1	Z2	AT*1	L	QK	b	h	t1				
12	20	M4	M5	M3	12	16	4	4	2.5	0.72	VRSF05B100PCJ	1/5	100 W
12	20	M4	M5	M3	12	16	4	4	2.5	0.72	VRSF09B100PCJ	1/9	
12	20	M4	M5	M3	12	16	4	4	2.5	0.87	VRSF15B100PCJ	1/15	
12	20	M4	M5	M3	12	16	4	4	2.5	0.87	VRSF25B100PCJ	1/25	
12	20	M5	M5	M4	12	16	4	4	2.5	0.85	VRSF05B200PCJ	1/5	200 W
19	30	M5	M6	M4	20	22	6	6	3.5	1.80	VRSF09C200PCJ	1/9	
19	30	M5	M6	M4	20	22	6	6	3.5	2.20	VRSF15C200PCJ	1/15	
19	30	M5	M6	M4	20	22	6	6	3.5	2.20	VRSF25C200PCJ	1/25	400 W
19	30	M5	M6	M4	20	22	6	6	3.5	1.80	VRSF05C400PCJ	1/5	
19	30	M5	M6	M4	20	22	6	6	3.5	1.80	VRSF09C400PCJ	1/9	
19	30	M5	M6	M4	20	22	6	6	3.5	2.20	VRSF15C400PCJ	1/15	
19	30	M5	M6	M4	20	22	6	6	3.5	2.20	VRSF25C400PCJ	1/25	

\*1. This is the set bolt.

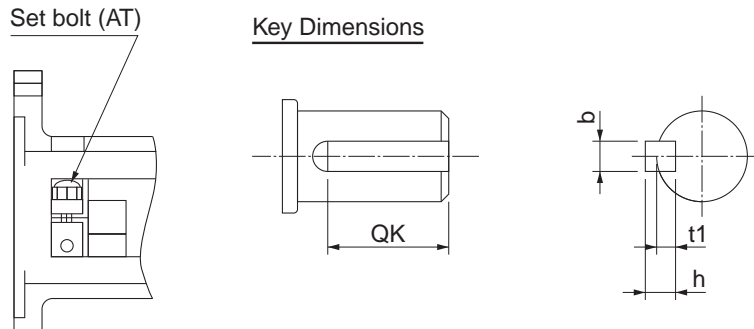

## External Regeneration Resistor Dimensions

### External Regeneration Resistor

#### R88A-RR08050S/R88A-RR080100S

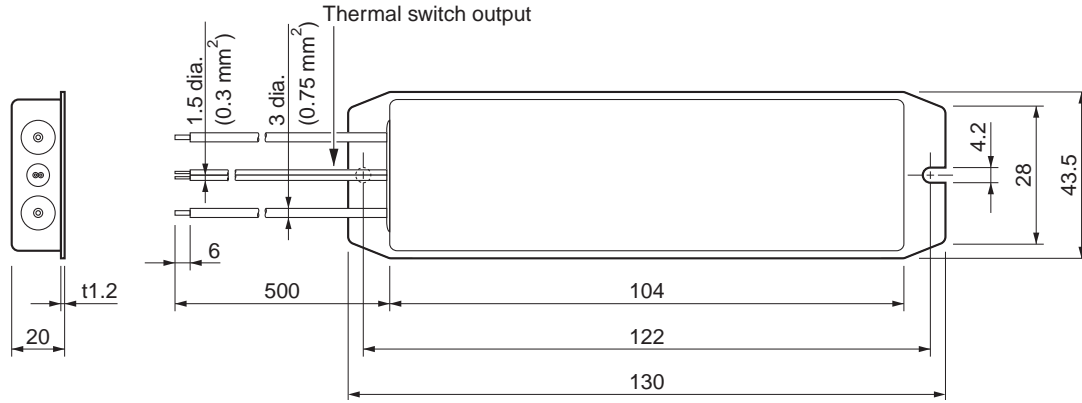

#### R88A-RR22047S

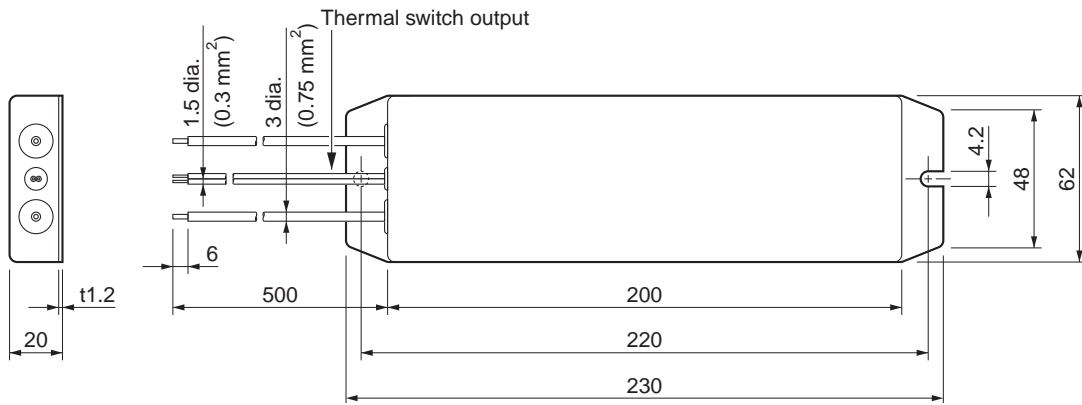

## Reactor Dimensions

### ■ 3G3AX-DL2002/-DL2004

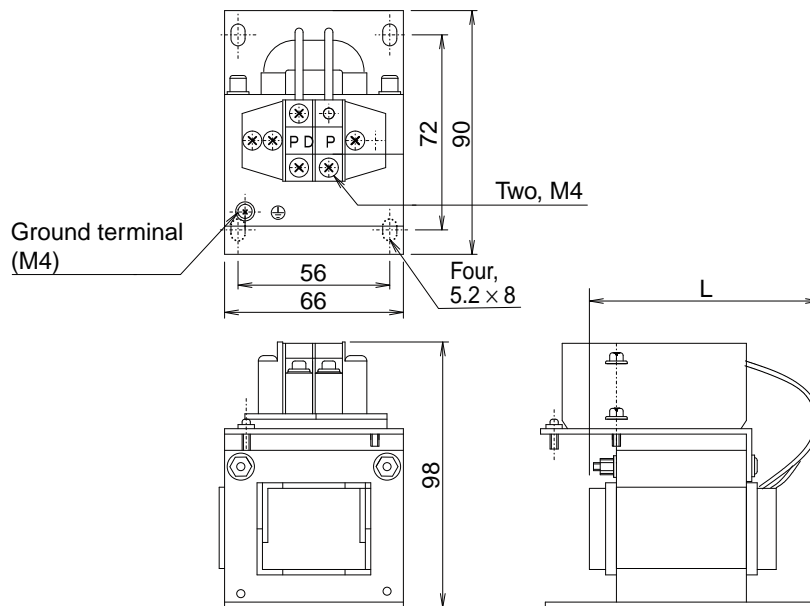

Model	Dimension (mm)
	L
3G3AX-DL2002	85
3G3AX-DL2004	95

### ■ 3G3AX-DL2007

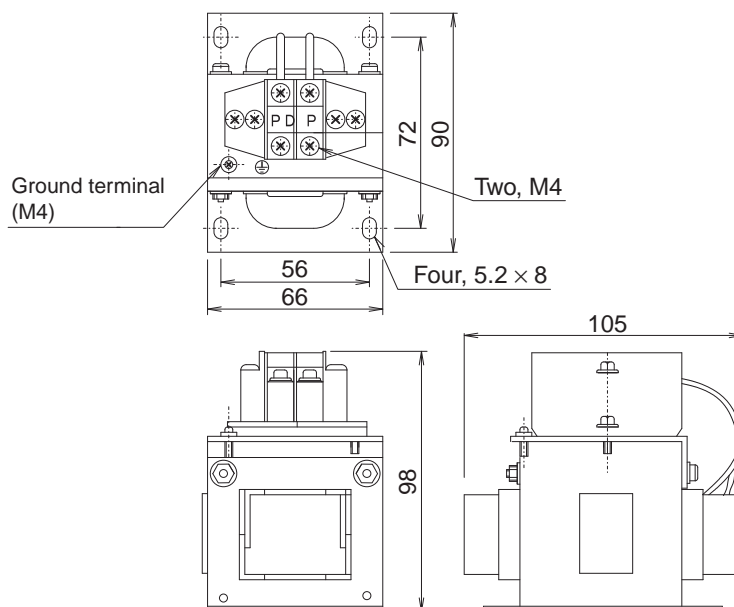

## 2-2 External and Mounted Dimensions

### ■ 3G3AX-AL2025

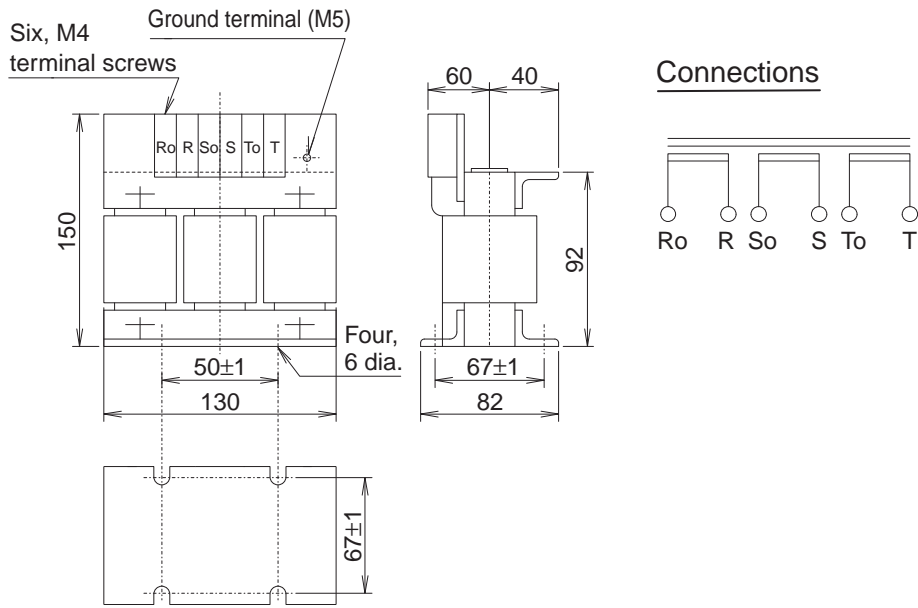

## DIN Rail Mounting Unit Dimensions

### R7A-DIN01B

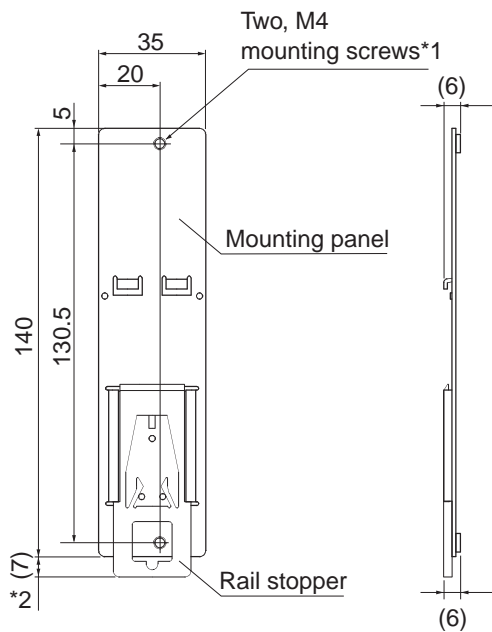

\*1. Two mounting screws (M4, length: 8) are included.

\*2. When the rail stopper is extended, this dimension becomes 10 mm.



# Chapter 3

## Specifications

<b>3-1</b>	<b>Servo Drive Specifications</b> .....	<b>3-1</b>
	General Specifications .....	3-1
	Characteristics .....	3-2
	Main Circuit and Servomotor Connector Specifications (CNA and CNB) .....	3-3
	Control I/O Connector Specifications (CN1) .....	3-4
	Control Input Circuits .....	3-8
	Control Input Details .....	3-9
	Control Output Circuits.....	3-12
	Control Output Details.....	3-13
	Encoder Connector Specifications (CN2) .....	3-15
<b>3-2</b>	<b>Servomotor Specifications</b> .....	<b>3-16</b>
	General Specifications .....	3-16
	Characteristics .....	3-17
	Encoder Specifications .....	3-25
<b>3-3</b>	<b>Decelerator Specifications</b> .....	<b>3-26</b>
	Standard Models and Specifications.....	3-26
<b>3-4</b>	<b>Cable and Connector Specifications</b> .....	<b>3-30</b>
	Encoder Cable Specifications .....	3-30
	Servomotor Power Cable Specifications.....	3-32
	Power Cable Specifications .....	3-36
	Communications Cable Specifications.....	3-39
	Connector Specifications .....	3-40
	Control Cable Specifications.....	3-44
<b>3-5</b>	<b>Servo Relay Units and Cable Specifications</b> .....	<b>3-52</b>
	Servo Relay Units Specifications .....	3-52
	Servo Drive-Servo Relay Unit Cable Specifications .....	3-62
	Position Control Unit-Servo Relay Unit Cable Specifications .....	3-65
<b>3-6</b>	<b>Parameter Unit Specifications</b> .....	<b>3-77</b>
<b>3-7</b>	<b>External Regeneration Resistors Specifications</b> .....	<b>3-78</b>
<b>3-8</b>	<b>Reactor Specifications</b> .....	<b>3-79</b>

# 3-1 Servo Drive Specifications

Select the Servo Drive matching the Servomotor to be used.  
 (For details, refer to *Servo Drive-Servomotor Combinations* on page 2-2.)

## General Specifications

Item		Specifications	
Ambient operating temperature Ambient operating humidity		0 to 55°C, 90% RH max. (with no condensation)	
Ambient storage temperature Ambient storage humidity		-20 to 65°C, 90% RH max. (with no condensation)	
Storage and operating atmosphere		No corrosive gasses, no dust, no iron dust, no exposure to moisture or cutting oil	
Vibration resistance		10 to 60 Hz; acceleration: 5.9 m/s <sup>2</sup> (0.6 G) max.	
Impact resistance		Acceleration of 19.6 m/s <sup>2</sup> max. 3 times each in X, Y, and Z directions.	
Insulation resistance		Between power supply/power line terminals and frame ground: 0.5 MΩ. min. (at 500 VDC)	
Dielectric strength		Between power supply/power line terminals and frame ground: 1,500 VAC for 1 min at 50/60 Hz Between each control signal and frame ground: 500 VAC for 1 min	
Altitude		1,000 m above sea level max. (860 hp min.)	
Protective structure		Built into panel (IP10).	
International standards	EC Directives	EMC Directive	EN 55011 class A group 1 EN 61000-6-2
		Low Voltage Directive	EN 50178
	UL standards		UL 508C
	cUL standards		cUL C22.2 No.14

**Note 1.** The above items reflect individual evaluation testing. The results may differ under compound conditions.

**Note 2.** Depending on the operating conditions, some Servo Drive parts will require maintenance. Refer to *Servo Drive Service Life* on page 8-18 in the User's Manual for details.

**Note 3.** The service life of the Servo Drive is 50,000 hours at an average ambient temperature of 40°C at 80% of the rated torque (excluding axial-flow fan).

### WARNING

Never perform withstand-voltage or other megameter tests on the Servo Drive.

Characteristics

■ Control Specifications

Item	Servo Drive model		
	R7D-BPA5L	R7D-BP01L	R7D-BP02L
Continuous output current (rms)	1.0 A	1.6 A	2.5 A
Momentary maximum output current (rms)	3.3 A	5.1 A	7.5 A
Power supply capacity	0.16 KVA	0.25 KVA	0.42 KVA
Input power supply voltage (main circuit)	Single-phase 100 to 115 VAC (85 to 127 V), 50/60 Hz		
Input power supply current (rms) (main circuit)	1.4 A	2.2 A	3.7 A
Heat generated (main circuit)	12 W	16 W	22 W
Control method	All-digital servo		
Inverter method	IGBT-driven PWM method		
PWM frequency	12 kHz		6 kHz
Maximum response frequency (command pulses)	Line driver: 500 kpps, Open collector: 200 kpps		
Weight	0.35 kg		0.42 kg
Applicable motor capacity	50 W	100 W	200 W

Item	Servo Drive model			
	R7D-BP01H	R7D-BP02HH	R7D-BP02H	R7D-BP04H
Continuous output current (rms)	1.0 A	1.6 A	1.6 A	2.5 A
Momentary maximum output current (rms)	3.3 A	4.9 A	4.9 A	7.8 A
Power supply capacity	0.27 KVA (0.30 KVA) <sup>*1</sup>	0.35 KVA	0.42 KVA	0.69 KVA (0.77 KVA) <sup>*1</sup>
Input power supply voltage (main circuit)	Both single-phase and three-phase 200 to 240 VAC (170 to 264 V), 50/60 Hz			
Input power supply current (rms) (main circuit)	0.7 A (1.5 A) <sup>*1</sup>	1.6 A	1.1 A	1.8 A (3.5 A) <sup>*1</sup>
Heat generated (main circuit)	14 W	16 W	20 W	26W
Control method	All-digital servo			
Inverter method	IGBT-driven PWM method			
PWM frequency	12 kHz			6 kHz
Maximum response frequency (command pulses)	Line driver: 500 kpps, Open collector: 200 kpps			
Weight	0.35 kg		0.42 kg	
Applicable motor capacity	100 W	200 W	200 W	400 W

\*1. Values inside parentheses ( ) are for single-phase 200-V use.

**Main Circuit and Servomotor Connector Specifications (CNA and CNB)**

■ R7A-CNB01P Main Circuit Connector (CNA) Specifications

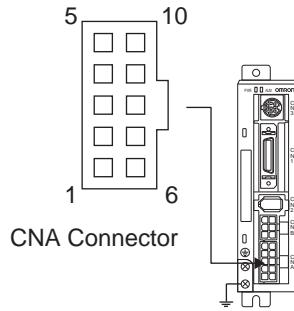

**Main Circuit Connector (CNA) Pin Arrangement**

Symbol	Pin No.	Name	Function
L1	10	Main circuit power supply input terminals	For three-phase 200 V, connect to L1 (pin 10), L2 (pin 8), and L3 (pin 6). For single-phase 100/200 V, connect to L1 (pin 10) and L3 (pin 6).
L2	8		
L3	6		
P	5	External Regeneration Resistor connection terminals	If regenerative energy is high, connect an External Regeneration Resistor.
B1	3		
FG	1	Frame ground	This is the ground terminal. Ground to 100 Ω or less.

■ R7A-CNB01A Servomotor Connector (CNB) Specifications

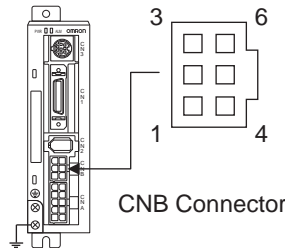

**Servomotor Connector (CNB) Pin Arrangement**

Symbol	Pin No.	Name	Color	Function
U	1	Servomotor connection terminals	Red	These are the output terminals to the Servomotor. Be careful to wire them correctly.
V	4		White	
W	6		Blue	
⊕	3	Frame ground	Green/ Yellow	Connect the Servomotor FG terminals.

### Control I/O Connector Specifications (CN1)

#### Control I/O Signal Connections and External Signal Processing

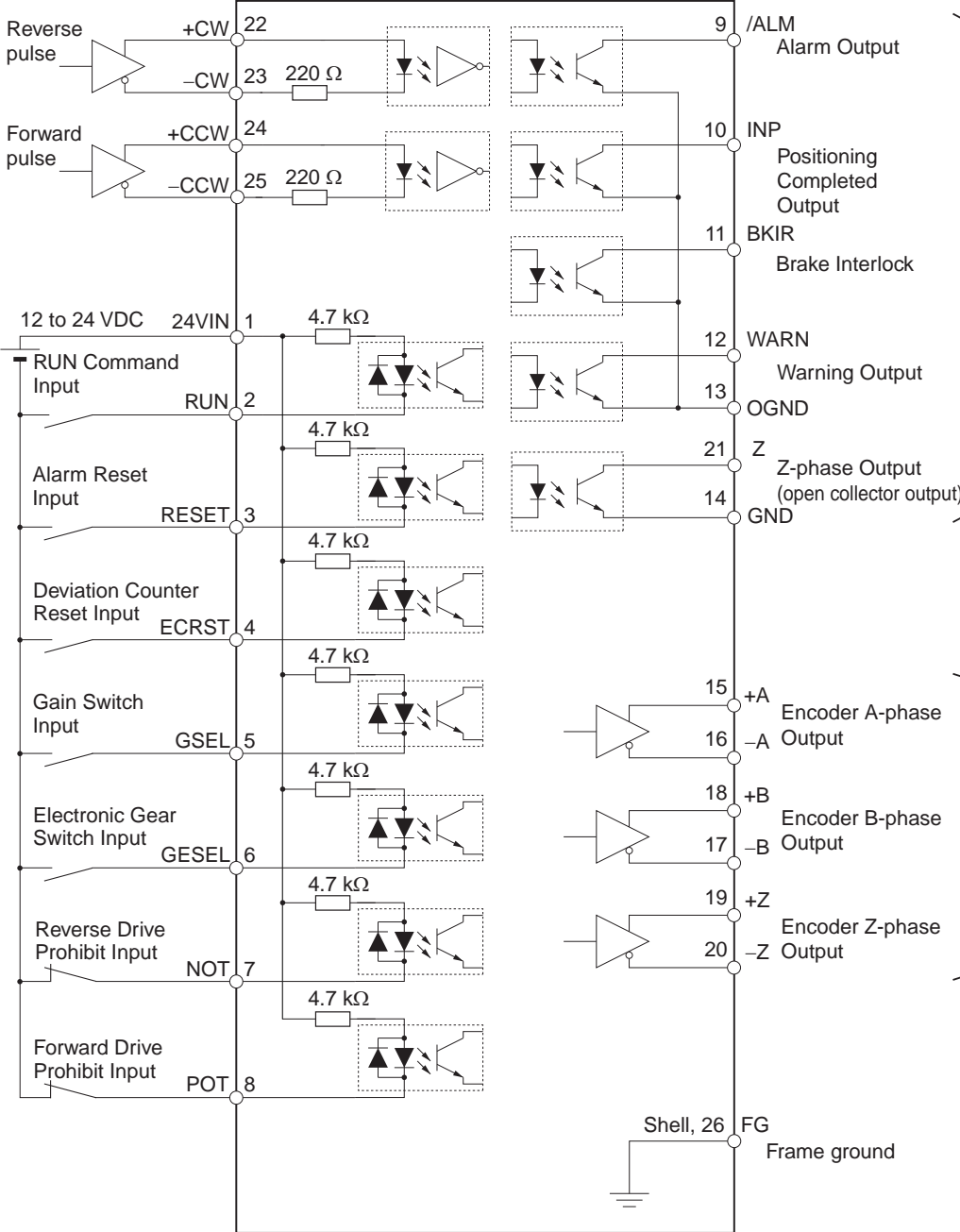

Maximum operating voltage: 30 VDC  
 Maximum Output Current: 50 mA DC

Line driver output  
 Conforms to EIA RS-422A  
 (Load resistance: 220 Ω min.)

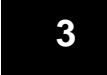

Specifications

### 3-1 Servo Drive Specifications

#### ■ Control I/O Signals

##### Control Inputs (CN1)

Pin No.	Signal name	Name	Function/Interface
1	+24VIN	DC power supply input for control	Power supply input terminal (12 to 24 VDC) for sequence input (pin 1).
2	RUN	RUN Command Input	ON: Servo ON (Starts power to Servomotor.)
3	RESET	Alarm Reset Input	ON: Servo alarm status is reset. <sup>*1</sup> Must be ON for 120 ms min.
4	ECRST/ VSEL2	Deviation Counter Reset Input or Internally Set Speed Selection 2 Input	Deviation Counter Reset Input in Position Control Mode (when Pn02 is set to 0 or 2). ON: Pulse commands prohibited and deviation counter cleared. Must be ON for at least 2 ms.
			Internally set speed selection 2 in Internal Speed Control Mode (when Pn02 is set to 1). ON: Internally Set Speed Selection 2 Input.
5	GSEL/ VZERO/ TLSEL	Gain Switch Input, Zero Speed Designation Input, or Torque Limit Switch Input	Gain Switch Input in Position Control Mode (when Pn02 is set to 0 or 2) when Zero Speed Designation/Torque Limit Switch (Pn06) is set to 0 or 1.
			Zero speed designation input in Internal Speed Control Mode (when Pn02 is set to 1). OFF: Speed command is zero. Input can also be disabled by the Zero Speed Designation/Torque Limit Switch (Pn06) setting: Enabled: Pn06 = 1, Disabled: Pn06 = 0
			Torque limit selection in both Position Control Mode and Internal Speed Control Mode when Zero Speed Designation/Torque Limit Switch (Pn06) is set to 2. OFF: Torque limit 1 enabled. (Pn70, 5E, 63) ON: Torque limit 2 enabled. (Pn71, 72, 73)
6	GESEL/ VSEL1	Electronic Gear Switch Input or Internally Set Speed Selection 1 Input	Electronic Gear Switch Input in Position Control Mode (when Pn02 is set to 0 or 2). <sup>*2</sup> OFF: Electronic Gear Ratio Numerator 1 (Pn46) ON: Electronic Gear Ratio Numerator 2 (Pn47)
			Internally set speed selection 1 in Internal Speed Control Mode (when Pn02 is set to 1). ON: Internally set speed selection 1 is input.
7	NOT	Reverse Drive Prohibit Input	Reverse rotation overtravel input. OFF: Prohibited, ON: Permitted
8	POT	Forward Drive Prohibit Input	Forward rotation overtravel input. OFF: Prohibited, ON: Permitted

\*1. Some alarms cannot be cleared using this input. For details, refer to 8-2 Alarm Table.

\*2. Do not input command pulses for 10 ms before or after switching the electronic gear.

Pin No.	Signal name	Name	Function/Interface
22	+CW/ PULS/FA	Reverse Pulses Input, Feed Pulses Input, or 90° Phase	Input terminals for position command pulses.  Line-driver input: Maximum response frequency: 500 kpps Open-collector input: Maximum response frequency: 200 kpps  Any of the following can be selected by using the Pn42 setting: forward and reverse pulses (CW/CCW); feed pulse and direction signal (PULS/SIGN); 90° phase difference (phase A/B) signals (FA/FB).
23	-CW/ PULS/FA	Difference Pulses (Phase A)	
24	+CCW/ SIGN/FB	Forward Pulses, Direction Signal, or 90° Phase	
25	-CCW/ SIGN/FB	Difference Pulses (Phase B)	

**Control Outputs (CN1)**

Pin No.	Signal name	Name	Function/Interface
9	/ALM	Alarm Output	When the Servo Drive generates an alarm, the output turns OFF. *1
10	INP/TGON	Positioning Completed Output or Servomotor Rotation Speed Detection Output	Positioning completed output in Position Control Mode (when Pn02 is set to 0 or 2). ON: The residual pulses for the deviation counter are within the setting for Positioning Completion Range (Pn60).  Motor rotation detection output in Internal Speed Control Mode (when Pn02 is set to 1). ON: The number of Servomotor rotations exceeds the value set for Servomotor Rotation Detection Speed (Pn62).
11	BKIR	Brake Interlock Output	Outputs the holding brake timing signals. Release the holding brake when this signal is ON.
12	WARN	Warning Output	The signal selected in the Warning Output Selection (Pn09) is output.
13	OGND	Output Ground Common	Ground common for sequence outputs (pins 9, 10, 11, and 12).
14	GND	Ground Common	Common for Encoder output and phase-Z output (pin 21).
15	+A	Encoder Phase-A Output	These signals output encoder pulses according to the Encoder Dividing Ratio Setting (Pn44).
16	-A		
17	-B	Encoder Phase-B Output	This is the line-driver output (equivalent to RS-422).
18	+B		
19	+Z	Encoder Phase-Z Output	
20	-Z		
21	Z	Phase-Z Output	Outputs the phase Z for the Encoder (1 pulse/rotation). This is the open-collector output.

\*1. This is OFF for approximately 2 seconds after turning ON the power.

**Note** An open-collector output interface is used for sequence outputs (maximum operating voltage: 30 VDC; maximum output current: 50 mA).

### 3-1 Servo Drive Specifications

#### ■ Control I/O Signal (CN1) Pin Arrangement

2	RUN	RUN Command Input	1	+24VIN	12 to 24 VDC power supply input for control	15	+A	Encoder Phase-A + Output	14	GND	Ground Common
4	ECRST/ VSEL2	Deviation Counter Reset/ Internally Set Speed Selection 2	3	RESET	Alarm Reset Input	17	-B	Encoder Phase-B - Output	16	-A	Encoder Phase-A - Output
6	GESEL/ VSEL1	Electronic Gear Switch/ Internally Set Speed Selection 1	5	GSEL/ VZERO/ TLSEL	Gain Switch/ Zero Speed Designation/ Torque Limit Switch	19	+Z	Encoder Phase-Z + Output	18	+B	Encoder Phase-B + Output
8	POT	Forward Drive Prohibit Input	7	NOT	Reverse Drive Prohibit	21	Z	Phase-Z Output	20	-Z	Encoder Phase-Z - Output
10	INP/ TGON	Positioning Completed/ Servomotor Rotation Speed Detection	9	/ALM	Alarm Output	23	-CW/ -PULS/ -FA	- Reverse Pulses/ - Feed Pulses/ - Phase-A	22	+CW/ +PULS/ +FA	+ Reverse Pulses/ + Feed Pulses/ + Phase-A
12	WARN	Warning Output	11	BKIR	Brake Interlock Output	25	-CCW/ -SIGN/ -FB	- Forward Pulses/ - Forward Pulse/ Reverse Pulse/ - Phase-B	24	+CCW/ +SIGN/ +FB	+ Forward Pulses/ + Forward Pulse/ Reverse Pulse/ + Phase-B
			13	OGND	Output Ground Common				26	FG	Frame ground

#### ■ CN1 Connectors (26 Pins)

##### Soldered Connectors

Name	Model	Manufacturer
Servo Drive Connector	5178238-4	Tyco Electronics AMP
Cable plug	10126-3000PE	Sumitomo 3M
Cable case (shell kit)	10326-52A0-008	



**Control Input Circuits**

**Position Command Pulse Inputs**

**Line Driver Input**

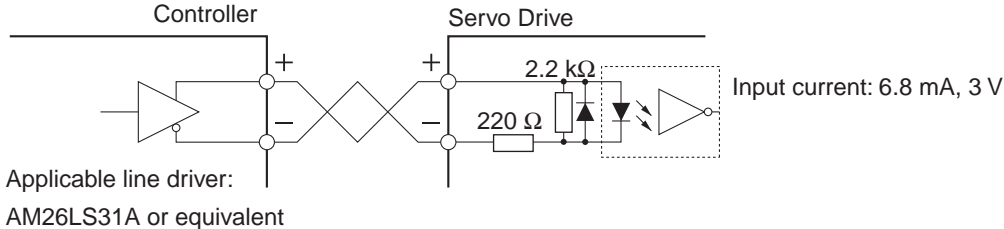

**Precautions for Correct Use**

♦ The twisted-pair cable should not exceed 10 m in length.

**Open-collector Input**

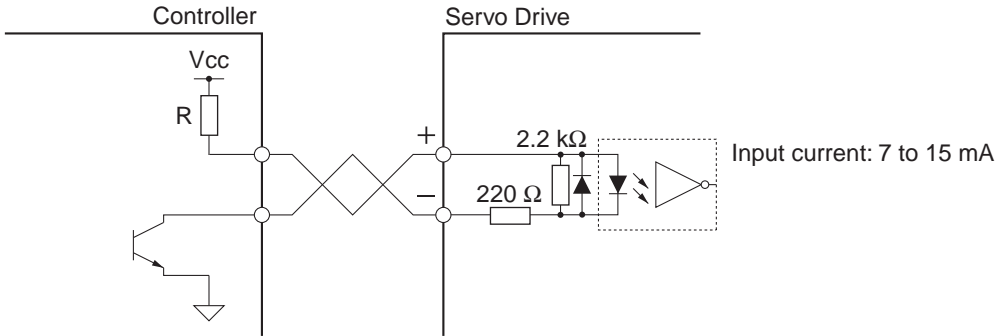

**Note** Select a value for resistance R so that the input current will be from 7 to 15 mA. Refer to the following table.

Vcc	R
24 V	2 kΩ
12 V	1 kΩ

**Precautions for Correct Use**

♦ The twisted-pair cable should not exceed 2 m in length.

**Control Inputs**

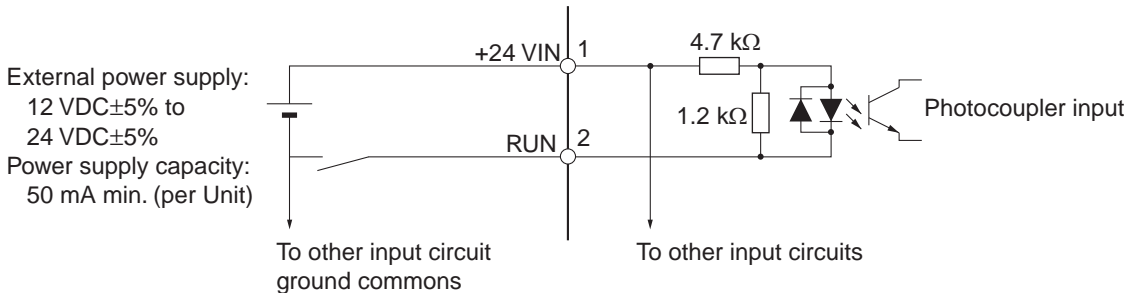

Signal Levels  
ON level: 10 V min.  
OFF level: 3 V max.

### Control Input Details

Details on the input pins for the CN1 connector are described here.

#### ■ RUN Command Input (RUN)

Pin 2: RUN Command Input (RUN)

##### Function

- ♦ This input turns ON the power drive circuit for the main circuit of the Servo Drive. The Servomotor cannot operate without the input of this signal (i.e., servo-OFF status).
- ♦ The RUN Command Input is enabled approximately 2 seconds after the power supply is turned ON.
- ♦ After turning ON the RUN Command Input, wait for a minimum of 100 ms to lapse before inputting pulses or a speed command.

#### ■ Alarm Reset Input

Pin 3: Alarm Reset Input (RESET)

##### Function

- ♦ Pin 3 is the external reset signal input for Servo Drive alarms. (The alarms are reset when this signal is input.)
- ♦ Eliminate the cause of the alarm before resuming operation. To prevent danger, turn OFF the RUN Command Input first, then input the alarm reset signal.
- ♦ Resetting is performed after the Alarm Reset Input is kept ON for 120 ms or longer.
- ♦ Some alarms cannot be cleared using the Alarm Reset Input. For details, refer to *8-2 Alarm Table*.

#### ■ Deviation Counter Reset/Internally Set Speed Selection 2 Input

Pin 4: Deviation Counter Reset/Internally Set Speed Selection 2 Input (ECRST/VSEL2)

##### Function: Deviation Counter Reset

- ♦ Pin 4 is the Deviation Counter Reset Input (ECRST) in Position Control Mode (when Pn02 is set to 0 or 2).
- ♦ When the deviation counter reset signal turns ON, the value of the deviation counter will be reset and the position loop will be disabled.
- ♦ Input the reset signal for 2 ms minimum. The counter may not be reset if the signal is too short.

##### Function: Internally Set Speed Selection 2

- ♦ Pin 4 is the Internally Set Speed Selection 2 Input (VSEL2) in Internal Speed Control Mode (when Pn02 is set to 1).
- ♦ Four speeds can be selected by using pin 4 in combination with the Internally Set Speed Selection 1 Input (VSEL1).

## ■ Gain Switch/Zero Speed Designation/Torque Limit Switch Input

Pin 5: Gain Switch/Zero Speed Designation/Torque Limit Switch Input (GSEL/VZERO/TLSEL)

### Function: Gain Switch

- ♦ Pin 5 is the Gain Switch Input (GSEL) when Pn02 is set to 0 or 2 (Position Control Mode) and the Zero Speed Designation/Torque Limit Switch (Pn06) is set to anything other than 2.
- ♦ The Gain Switch Input (GSEL) switches between PI and P operation, or between gain 1 and gain 2.
- ♦ When the Gain Switch Input Operating Mode Selection (Pn30) is set to 0, this input switches between PI and P operation. When Pn30 is set to 1 and the Gain Switch Setting (Pn31) is set to 2, this input switches between gain 1 and gain 2.
- ♦ Gain 1 includes the Position Loop Gain (Pn10), Speed Loop Gain (Pn11), Speed Loop Integration Time Constant (Pn12), Speed Feedback Filter Time Constant (Pn13), and Torque Command Filter Time Constant (Pn14).
- ♦ Gain 2 includes the Position Loop Gain 2 (Pn18), Speed Loop Gain 2 (Pn19), Speed Loop Integration Time Constant 2 (Pn1A), Speed Feedback Filter Time Constant 2 (Pn1B), and Torque Command Filter Time Constant 2 (Pn1C).

### Function: Zero Speed Designation

- ♦ Pin 5 is the Zero Speed Designation Input (VZERO) when Pn02 is set to 1 (Internal Speed Control Mode) and the Zero Speed Designation/Torque Limit Switch (Pn06) is set to anything other than 2.
- ♦ When Zero Speed Designation Input (VZERO) is OFF, the speed command is zero. Turn ON the Zero Speed Designation Input (VZERO) for normal operation.
- ♦ Zero Speed Designation Input (VZERO) is enabled when the Zero Speed Designation/Torque Limit Switch (Pn06) is set to 1, and disabled when Pn06 is set to 0.

### Function: Torque Limit Switch

- ♦ Pin 5 is the Torque Limit Switch Input (TLSEL) in both Position Control Mode and Internal Speed Control Mode when the Zero Speed Designation/Torque Limit Switch (Pn06) is set to 2.
- ♦ This input switches the Overspeed Detection Level, Torque Limit, and Deviation Counter Overflow Level parameters.
- ♦ When the input is OFF, torque limit 1 (Pn70, Pn5E, Pn63) is enabled, and when the input is ON, torque limit 2 (Pn71, Pn72, Pn73) is enabled.

## ■ Electronic Gear Switch/Internally Set Speed Selection 1 Input

Pin 6: Electronic Gear Switch/Internally Set Speed Selection 1 Input (GESEL/VSEL1)

### Function: Electronic Gear Switch

- ♦ Pin 6 is the Electronic Gear Switch Input (GESEL) in Position Control Mode (when Pn02 is set to 0 or 2).
- ♦ The numerator setting for the electronic gear can be switched between Electronic Gear Ratio Numerator 1 and Electronic Gear Ratio Numerator 2.
- ♦ When the input is turned OFF, Electronic Gear Ratio Numerator 1 (Pn46) is enabled, and when the input is turned ON, Electronic Gear Ratio Numerator 2 (Pn47) is enabled.
- ♦ It takes 1 to 5 ms to switch the electronic gear after the Gear Switch input changes. Therefore, do not input a command pulse for 10-ms before and after switching.

#### Function: Internally Set Speed Selection 1

- ♦ Pin 6 is the Internally Set Speed Selection 1 Input (VSEL1) in Internal Speed Control Mode (when Pn02 is set to 1).
- ♦ Four speeds can be selected by using pin 6 in combination with the Internally Set Speed Selection 2 Input (VSEL2).

#### Reverse Drive Prohibit/Forward Drive Prohibit Input

Pin 7: Reverse Drive Prohibit Input (NOT)  
 Pin 8: Forward Drive Prohibit Input (POT)

#### Functions

- ♦ These inputs prohibit forward and reverse operation (overtravel).
- ♦ When an input is ON, operation is possible in that direction.
- ♦ These inputs can be disabled using the setting of Drive Prohibit Input Selection (Pn04).
- ♦ The motor will stop according to the setting of the Stop Selection for Drive Prohibition Input (Pn66).

#### Reverse Pulse/Forward Pulse, Feed Pulse/Direction Signal, 90° Phase Difference Signal (Phase A/Phase B)

Pin 22: +Reverse Pulse (+CW), +Feed Pulse (+PULS), or +Phase A (+FA)  
 Pin 23: -Reverse Pulse (-CW), -Feed Pulse (-PULS), or -Phase A (-FA)  
 Pin 24: +Forward Pulse (+CCW), +Direction Signal (+SIGN), or +Phase B (+FB)  
 Pin 25: -Forward Pulse (-CCW), -Direction Signal (-SIGN), or -Phase B (-FB)

#### Functions

The functions of these signals depend on the setting of the Command Pulse Mode (Pn42).

Setting	Command pulse mode	Input pins	Servomotor forward command	Servomotor reverse command
0 or 2	90° phase difference signals	22: +FA 23: -FA 24: +FB 25: -FB	<p>Line driver: <math>t_1 \geq 2 \mu\text{s}</math>                      Open collector: <math>t_1 \geq 5 \mu\text{s}</math></p>	
1	Reverse pulse/forward pulse	22: +CW 23: -CW 24: +CCW 25: -CCW	<p>Line driver: <math>t_2 \geq 1 \mu\text{s}</math>                      Open collector: <math>t_2 \geq 2.5 \mu\text{s}</math></p>	
3	Feed pulse/direction signal	22: +PULS 23: PULS 24: SIGN 25: -SIGN	<p>Line driver: <math>t_2 \geq 1 \mu\text{s}</math>                      Open collector: <math>t_2 \geq 2.5 \mu\text{s}</math></p>	

♦ If the photocoupler LED is turned ON, each signal will go high as shown above.

### Control Output Circuits

#### Position Feedback Output

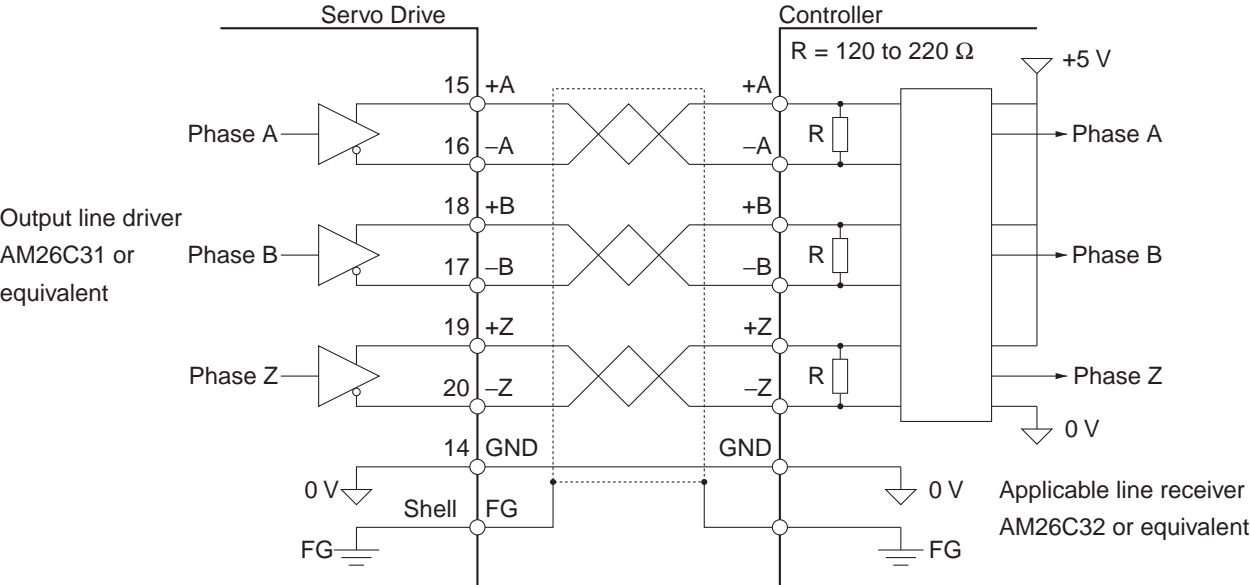

#### Control/Alarm Outputs

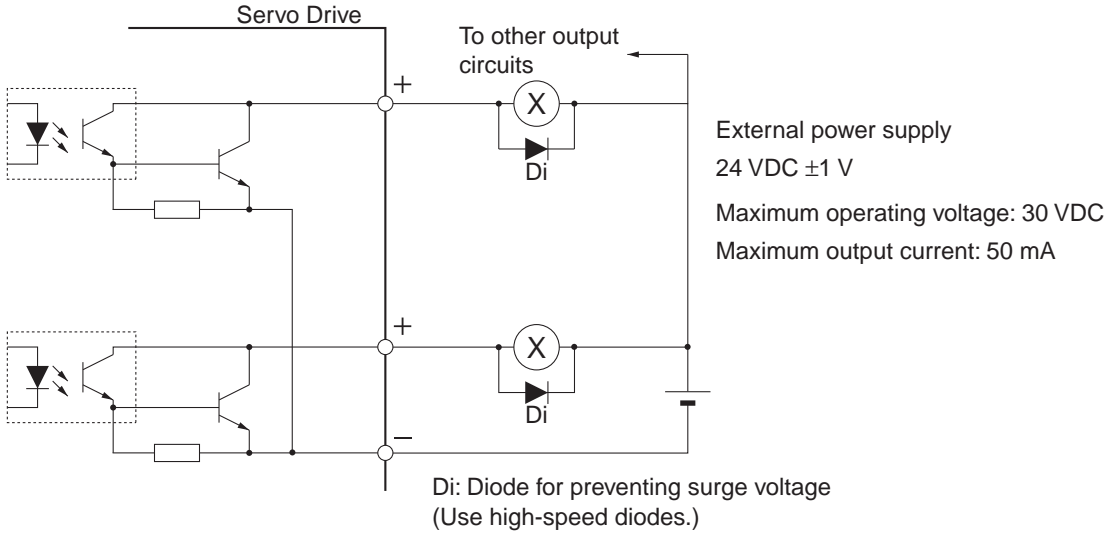

#### Phase-Z Output (Open-collector Output)

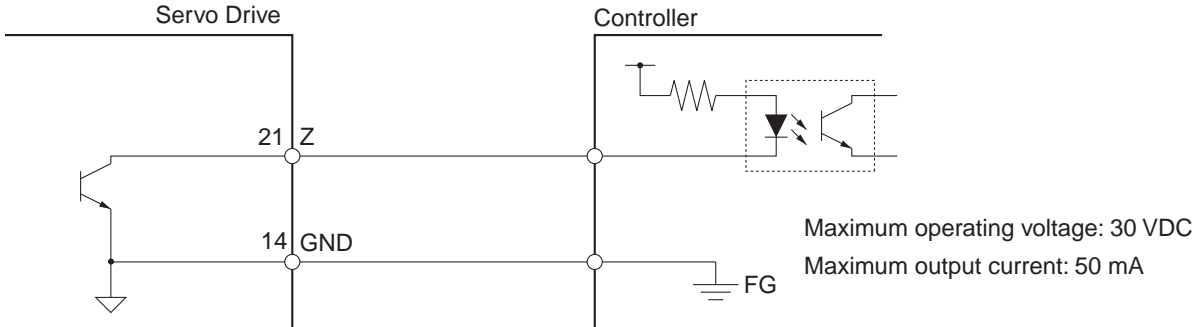

Specifications

## Control Output Details

The details of the output pins for the CN1 connector are described as follows.

### ■ Control Output Sequence

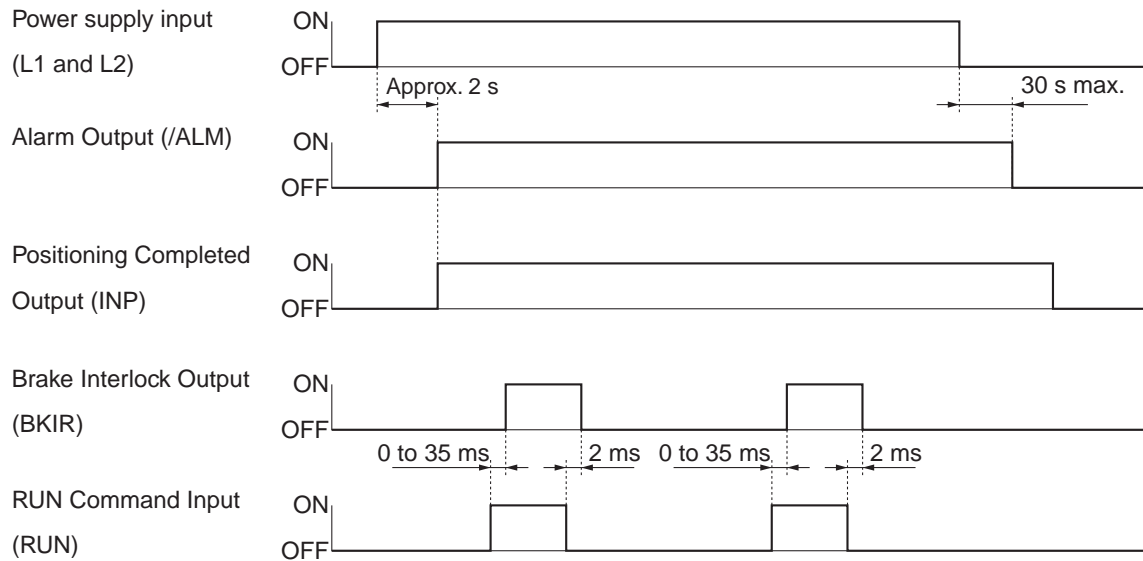

### ■ Alarm Output

Pin 9: Alarm Output (/ALM)

#### Function

- ♦ The alarm output is turned OFF when the Servo Drive detects an error.
- ♦ This output is OFF at startup, but turns ON when the initial processing of the Servo Drive has been completed.

### ■ Positioning Completed Output/Servomotor Rotation Speed Detection Output

Pin 10: Positioning Completed Output/Servomotor Rotation Speed Detection Output (INP/TGON)

#### Function: Positioning Completed Output

- ♦ Pin 10 is the Positioning Completed Output (INP) in Position Control Mode (when Pn02 is set to 0 or 2).
- ♦ The INP signal turns ON when the number of accumulated pulses in the deviation counter is less than the Positioning Completion Range (Pn60).

#### Function: Servomotor Rotation Speed Detection Output

- ♦ Pin 10 is the Servomotor Rotation Speed Detection Output (TGON) in Internal Speed Control Mode (when Pn02 is set to 1).
- ♦ The TGON signal turns ON when the motor rotation speed exceeds the Rotation Speed for Servomotor Rotation Detection (Pn62).

## ■ Brake Interlock Output

Pin 11: Brake Interlock Output (BKIR)

### Function

- ♦ The external brake timing signal is output.
- ♦ This output is turned ON to release the external brake.

## ■ Warning Output

Pin 12: Warning Output (WARN)

### Function

- ♦ Pin 12 outputs the warning signal selected in the Warning Output Selection (Pn09).

## ■ Feedback Output

Pin 15: Encoder Phase A+ Output (+A)

Pin 16: Encoder Phase A– Output (–A)

Pin 17: Encoder Phase B– Output (–B)

Pin 18: Encoder Phase B+ Output (+B)

Pin 19: Encoder Phase Z+ Output (+Z)

Pin 20: Encoder Phase Z– Output (–Z)

### Function

- ♦ This signal outputs encoder pulses according to the Encoder Divider Setting (Pn44).
- ♦ Line-driver output (equivalent to RS-422).
- ♦ The output logic can be reversed with Encoder Output Direction Switch (Pn45).

## ■ Phase-Z Output

Pin 21: Phase-Z Output (Z)

Pin 14: Ground Common (GND)

### Function

- ♦ Pin 21 is the open-collector output for the phase-Z signal.
- ♦ The encoder phase Z is output.
- ♦ One pulse is output for each rotation.

**Encoder Connector Specifications (CN2)**

Pin No.	Signal name	Name	Function/Interface
1	E5V	Encoder power supply +5 V	Power supply output for the encoder 5 V, 70 mA
2	E0V	Encoder power supply GND	
3	NC		Do not connect anything to these pins.
4	NC		
5	S+	Encoder + phase S I/O	RS-485 line-driver I/O
6	S-	Encoder - phase S I/O	
Shell	FG	Shield ground	Cable shield ground

■ **Connectors for CN2 (6 Pins)**

Name	Model	Maker
Servo Drive Connector	53460-0629	Molex Japan Co.
Cable Connector	55100-0670	

3

Specifications



## 3-2 Servomotor Specifications

Select a Servomotor based on the mechanical system's load conditions and the installation environment. There are various options available on the Servomotors, such as models with brakes.

### General Specifications

Item		Specifications	
Ambient operating temperature Ambient operating humidity		0 to 40°C, 85% RH max. (with no condensation)	
Ambient storage temperature Ambient storage humidity		-20 to 65°C, 85% RH max. (with no condensation)	
Storage and operating atmosphere		No corrosive gases	
Vibration resistance		49 m/s <sup>2</sup> max. in the X, Y, and Z directions	
Impact resistance		Acceleration of 98 m/s <sup>2</sup> max. 3 times each in the X, Y, and Z directions	
Insulation resistance		Between the power line terminals and FG: 20 MΩ min. (at 500 VDC)	
Dielectric strength		Between the power line terminals and FG: 1,500 VAC for 1 min at 50/60 Hz	
Operating position		All directions	
Insulation grade		Type B	
Structure		Totally-enclosed self-cooling	
Protective structure		IP65 (excluding through-shaft parts and lead wire ends)	
Vibration grade		V-15	
Mounting method		Flange-mounting	
International standards	EC Directives	EMC Directive	EN 60034-1:2004
		Low Voltage Directive	IEC 60034-5:2001
	UL standards		UL 1004 File No. E179189
	cUL standards		cUL 22.2, No.100

### ■ Motor Rotation Directions

In this manual, the Servomotors rotation directions are defined as forward and reverse. Viewed from the end of the motor's output shaft, counterclockwise (CCW) rotation is forward and clockwise (CW) rotation is reverse.

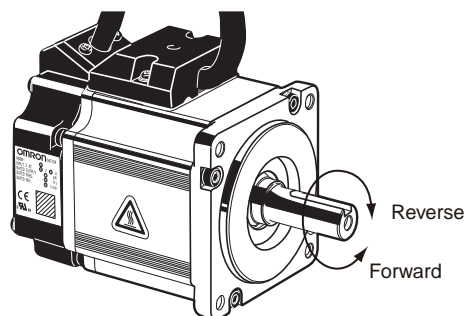

Characteristics

■ 3,000-r/min Cylindrical Servomotors

Item		Unit	R88M-G05030H	R88M-G10030L	R88M-G20030L
Rated output <sup>*1</sup>		W	50	100	200
Rated torque <sup>*1</sup>		N·m	0.16	0.32	0.64
Rated rotation speed		r/min	3000		
Max. rotation speed		r/min	5000		
Max. momentary torque <sup>*1</sup>		N·m	0.48	0.95	1.78
Rated current <sup>*1</sup>		A(rms)	1.1	1.7	2.5
Max. momentary current <sup>*1</sup>		A(rms)	3.4	5.1	7.6
Rotor inertia		kg·m <sup>2</sup>	2.5 × 10 <sup>-6</sup>	5.1 × 10 <sup>-6</sup>	1.4 × 10 <sup>-5</sup>
Applicable load inertia		---	30 times the rotor inertia max. <sup>*2</sup>		
Power rate <sup>*1</sup>		kW/s	10.4	20.1	30.3
Allowable radial load <sup>*3</sup>		N	68	68	245
Allowable thrust load <sup>*3</sup>		N	58	58	98
Weight	Without brake	kg	0.3	0.5	0.8
	With brake	kg	0.5	0.7	1.3
Radiation shield dimensions (material)		---	100 × 80 × t10 (Al)		130 × 120 × t12 (Al)
Brake specifications	Brake inertia	kg·m <sup>2</sup>	2.0 × 10 <sup>-7</sup>	2.0 × 10 <sup>-7</sup>	1.8 × 10 <sup>-6</sup>
	Excitation voltage <sup>*4</sup>	V	24 VDC ±10%		
	Power consumption (at 20°C)	W	7	7	9
	Current consumption (at 20°C)	A	0.30	0.30	0.36
	Static friction torque	N·m	0.29 min.	0.29 min.	1.27 min.
	Attraction time <sup>*5</sup>	ms	35 max.	35 max.	50 max.
	Release time <sup>*5</sup>	ms	20 max.	20 max.	15 max.
	Backlash		±1° max.		
	Allowable work per braking operation	J	39.2	39.2	137
	Allowable total work	J	4.9 × 10 <sup>3</sup>	4.9 × 10 <sup>3</sup>	44.1 × 10 <sup>3</sup>
	Allowable angular acceleration	rad/s <sup>2</sup>	30,000 max. (Speed of 2,800 r/min or more must not be changed in less than 10 ms)		
	Brake life	---	10,000,000 operations		
	Rating	---	Continuous		

Item		Unit	R88M-G05030H	R88M-G10030H	R88M-G20030H	R88M-G40030H
Rated output <sup>*1</sup>		W	50	100	200	400
Rated torque <sup>*1</sup>		N·m	0.16	0.32	0.64	1.3
Rated rotation speed		r/min	3000			
Max. rotation speed		r/min	5000			
Max. momentary torque <sup>*1</sup>		N·m	0.48	0.95	1.78	3.60
Rated current <sup>*1</sup>		A(rms)	1.1	1.1	1.6	2.6
Max. momentary current <sup>*1</sup>		A(rms)	3.4	3.4	4.9	7.9
Rotor inertia		kg·m <sup>2</sup>	$2.5 \times 10^{-6}$	$5.1 \times 10^{-6}$	$1.4 \times 10^{-5}$	$2.6 \times 10^{-5}$
Applicable load inertia		---	30 times the rotor inertia max. <sup>*2</sup>			
Power rate <sup>*1</sup>		kW/s	10.4	20.1	30.3	62.5
Allowable radial load <sup>*3</sup>		N	68	68	245	245
Allowable thrust load <sup>*3</sup>		N	58	58	98	98
Weight	Without brake	kg	0.3	0.5	0.8	1.2
	With brake	kg	0.5	0.7	1.3	1.7
Radiation shield dimensions (material)		---	100 × 80 × t10 (Al)		130 × 120 × t12 (Al)	
Brake specifications	Brake inertia	kg·m <sup>2</sup>	$2.0 \times 10^{-7}$	$2.0 \times 10^{-7}$	$1.8 \times 10^{-6}$	$7.5 \times 10^{-6}$
	Excitation voltage <sup>*4</sup>	V	24 VDC ±10%			
	Power consumption (at 20°C)	W	7	7	9	9
	Current consumption (at 20°C)	A	0.30	0.30	0.36	0.36
	Static friction torque	N·m	0.29 min.	0.29 min.	1.27 min.	1.27 min.
	Attraction time <sup>*5</sup>	ms	35 max.	35 max.	50 max.	50 max.
	Release time <sup>*5</sup>	ms	20 max.	20 max.	15 max.	15 max.
	Backlash		±1° max.			
	Allowable work per braking operation	J	39.2	39.2	137	196
	Allowable total work	J	$4.9 \times 10^3$	$4.9 \times 10^3$	$44.1 \times 10^3$	$147 \times 10^3$
	Allowable angular acceleration	rad/s <sup>2</sup>	30,000 max. (Speed of 2,800 r/min or more must not be stopped in less than 10 ms)			
	Brake life	---	10,000,000 operations			
	Rating	---	Continuous			

- \*1. These are the values when the Servomotor is combined with a Servo Drive at room temperature. The maximum momentary torque shown above indicates the standard value.
- \*2. For detailed information on the applicable load inertia, refer to *Applicable Load Inertia* on page 3-25.
- \*3. The allowable radial and thrust loads are the values determined for a service life of 20,000 hours at normal operating temperatures. The values are also for the locations shown in the following diagram.
- \*4. The brakes are non-excitation operation type. They are released when excitation voltage is applied.
- \*5. The operation time is the measured value (reference value) with a varistor installed as a surge suppressor.

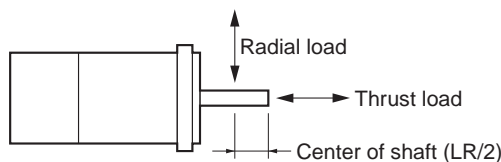

## 3-2 Servomotor Specifications

### ■ 3,000-r/min Flat Servomotors

Item		Unit	R88M-GP10030L	R88M-GP20030L
Rated output <sup>*1</sup>		W	100	200
Rated torque <sup>*1</sup>		N·m	0.32	0.64
Rated rotation speed		r/min	3,000	
Max. rotation speed		r/min	5,000	
Max. momentary torque <sup>*1</sup>		N·m	0.85	1.86
Rated current <sup>*1</sup>		A(rms)	1.6	2.5
Max. momentary current <sup>*1</sup>		A(0-p)	6.9	10.5
Rotor inertia		kg·m <sup>2</sup>	$9.0 \times 10^{-6}$	$3.4 \times 10^{-5}$
Applicable load inertia		---	20 times the rotor inertia max. <sup>*2</sup>	
Power rate <sup>*1</sup>		kW/s	11.4	12.0
Allowable radial load <sup>*3</sup>		N	68	245
Allowable thrust load <sup>*3</sup>		N	58	98
Weight	Without brake	kg	0.65	1.3
	With brake	kg	0.90	2.0
Radiation shield dimensions (material)		---	130 × 120 × t10 (Al)	170 × 160 × t12 (Al)
Brake specifications	Brake inertia	kg·m <sup>2</sup>	$3.0 \times 10^{-6}$	$9.0 \times 10^{-6}$
	Excitation voltage <sup>*4</sup>	V	24 VDC ±10%	
	Power consumption (at 20°C)	W	7	10
	Current consumption (at 20°C)	A	0.29	0.41
	Static friction torque	N·m	0.29 min.	1.27 min.
	Attraction time <sup>*5</sup>	ms	50 max.	60 max.
	Release time <sup>*5</sup>	ms	15 max.	15 max.
	Backlash		±1° max.	
	Allowable work per braking operation	J	137	196
	Allowable total work	J	$44.1 \times 10^3$	$147 \times 10^3$
	Allowable angular acceleration	rad/s <sup>2</sup>	10,000 max. (Speed of 950 r/min or more must not be stopped in less than 10 ms)	
	Brake life	---	10,000,000 operations	
	Rating	---	Continuous	

Item		Unit	R88M-GP10030H	R88M-GP20030H	R88M-GP40030H
Rated output *1		W	100	200	400
Rated torque*1		N·m	0.32	0.64	1.3
Rated rotation speed		r/min	3000		
Max. rotation speed		r/min	5000		
Max. momentary torque *1		N·m	0.90	1.82	3.60
Rated current *1		A(rms)	1.0	1.6	4.4
Max. momentary current *1		A(0-p)	4.3	6.8	18.6
Rotor inertia		kg·m <sup>2</sup>	$9.0 \times 10^{-6}$	$3.4 \times 10^{-5}$	$6.4 \times 10^{-5}$
Applicable load inertia		---	20 times the rotor inertia max.*2		
Power rate*1		kW/s	11.4	11.8	25.5
Allowable radial load *3		N	68	245	245
Allowable thrust load*3		N	58	98	98
Weight	Without brake	kg	0.7	1.3	1.8
	With brake	kg	0.9	2.0	2.5
Radiation shield dimensions (material)		---	130 × 120 × t10 (Al)	170 × 160 × t12 (Al)	
Brake specifications	Brake inertia	kg·m <sup>2</sup>	$3.0 \times 10^{-6}$	$9.0 \times 10^{-6}$	$9.0 \times 10^{-6}$
	Excitation voltage *4	V	24 VDC ±10%		
	Power consumption (at 20°C)	W	7	10	10
	Current consumption (at 20°C)	A	0.29	0.41	0.41
	Static friction torque	N·m	0.29 min.	1.27 min.	1.27 min.
	Attraction time *5	ms	50 max.	60 max.	60 max.
	Release time*5	ms	15 max.	15 max.	15 max.
	Backlash		±1° max.		
	Allowable work per braking operation	J	137	196	196
	Allowable total work	J	$44.1 \times 10^3$	$147 \times 10^3$	$147 \times 10^3$
	Allowable angular acceleration	rad/s <sup>2</sup>	10,000 max. (Speed of 950 r/min or more must not be stopped in less than 10 ms)		
	Brake life	---	10,000,000 operations		
	Rating	---	Continuous		

\*1. These are the values when the Servomotor is combined with a Servo Drive at room temperature. The maximum momentary torque shown above indicates the standard value.

\*2. For detailed information on the applicable load inertia, refer to *Applicable Load Inertia* on page 3-25.

\*3. The allowable radial and thrust loads are the values determined for a service life of 20,000 hours at normal operating temperatures. The values are also for the locations shown in the following diagram.

\*4. The brakes are non-excitation operation type. They are released when excitation voltage is applied.

\*5. The operation time is the measured value (reference value) with a varistor installed as a surge suppressor.

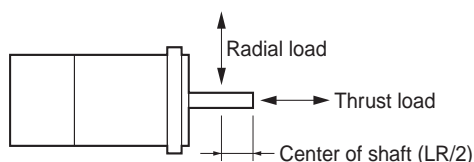

## 3-2 Servomotor Specifications

### ■ Torque and Rotation Speed Characteristics

#### 3,000-r/min Cylindrical Servomotors

The following graphs show the characteristics with a 3-m standard cable and a 100-VAC input.

R88M-G05030H

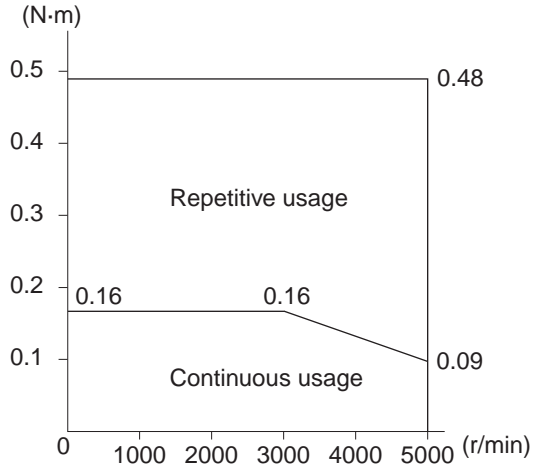

R88M-G10030L

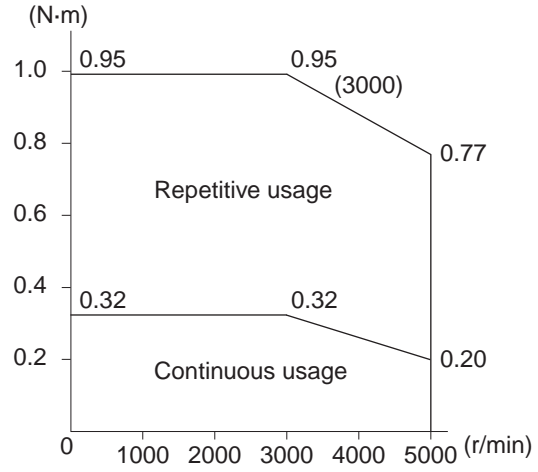

R88M-G20030L

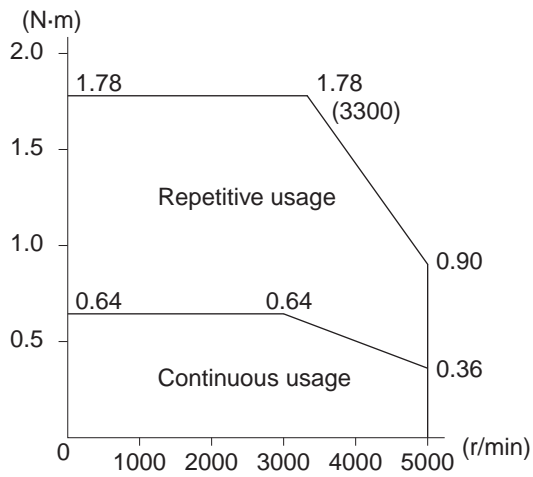

The following graphs show the characteristics with a 3-m standard cable and a 200-VAC input.

R88M-G10030H

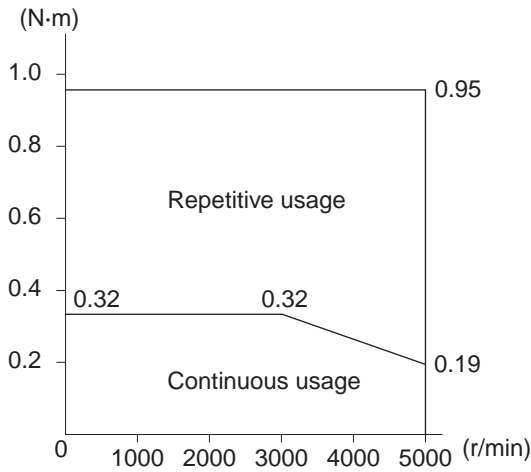

R88M-G20030H

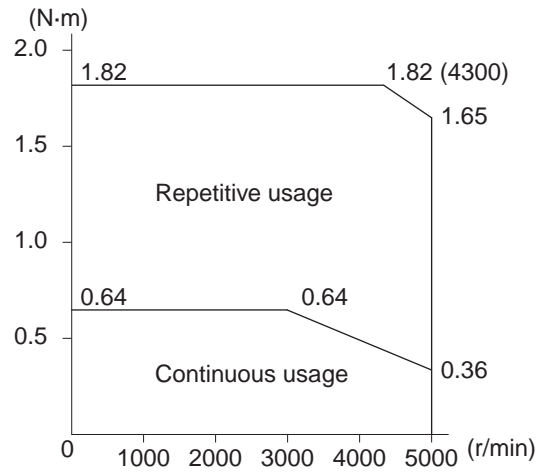

R88M-G40030H

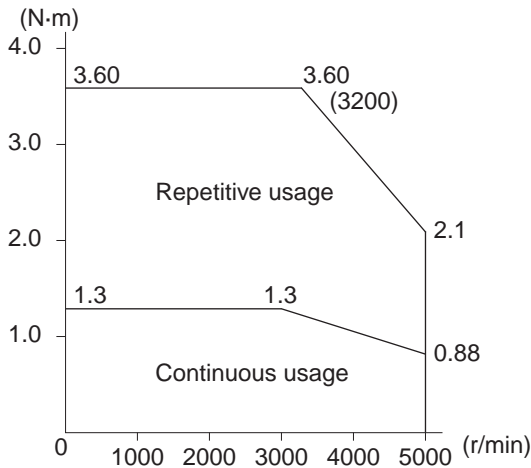

#### 3,000-r/min Flat Servomotors

The following graphs show the characteristics with a 3-m standard cable and a 100-VAC input.

R88M-GP10030L

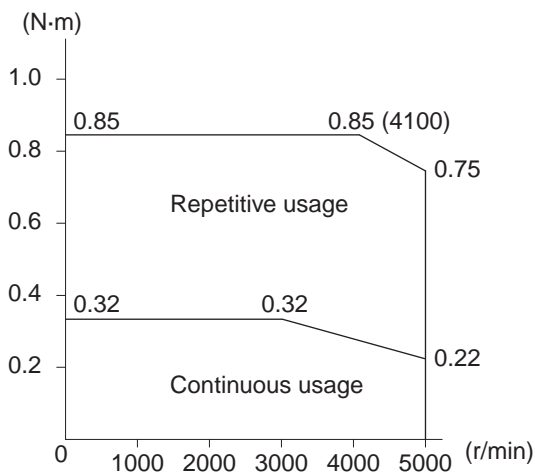

R88M-GP20030L

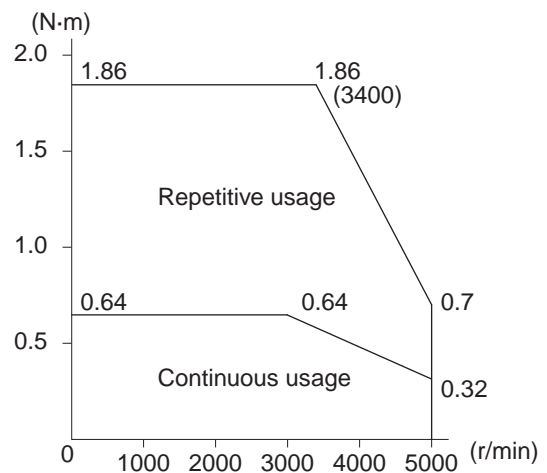

## 3-2 Servomotor Specifications

The following graphs show the characteristics with a 3-m standard cable and a 200-VAC input.

R88M-GP10030H

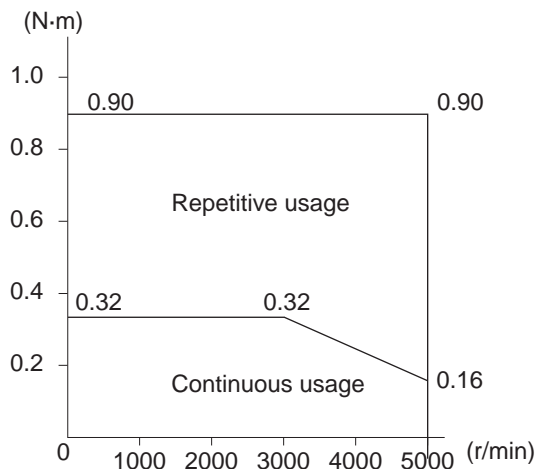

R88M-GP20030H

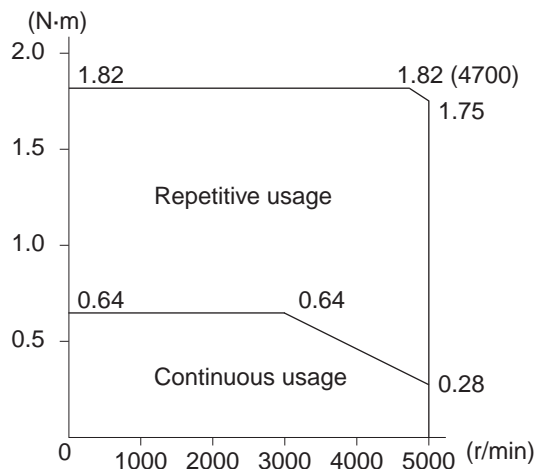

R88M-GP40030H

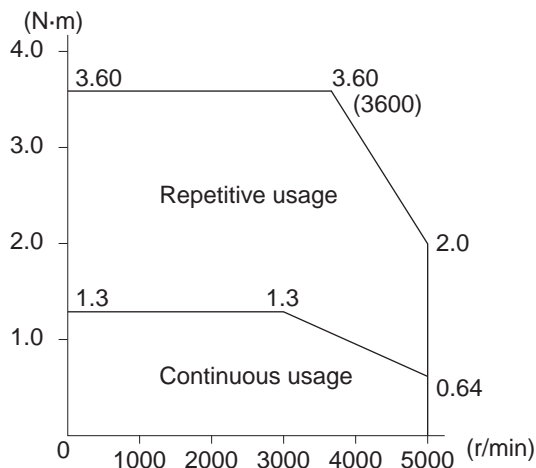

### ■ Temperature Characteristics of the Servomotor and Mechanical System

- ♦ OMNUC G-Series Servomotors use rare earth magnets (neodymium-iron magnets).
- ♦ The temperature coefficient for these magnets is approximately  $-0.13\%/^{\circ}\text{C}$ . As the temperature drops, the Servomotor's maximum momentary torque increases, and as the temperature rises, the Servomotor's maximum momentary torque decreases.
- ♦ The maximum momentary torque rises by 4% at a normal temperature of  $20^{\circ}\text{C}$  compared to a temperature of  $-10^{\circ}\text{C}$ . Conversely, the maximum momentary torque decreases about 8% when the magnet warms up to  $80^{\circ}\text{C}$  from the normal temperature of  $20^{\circ}\text{C}$ .
- ♦ Generally, when the temperature drops in a mechanical system, the friction torque and the load torque increase. For that reason, overloading may occur at low temperatures. In particular, in systems that use a Decelerator, the load torque at low temperatures may be nearly twice as much as the load torque at normal temperatures. Check whether overloading may occur at low temperature startup. Also check to see whether abnormal Servomotor overheating or alarms occur at high temperatures.
- ♦ An increase in load friction torque seemingly increases load inertia. Therefore, even if the Servo Drive gains are adjusted at a normal temperature, the Servomotor may not operate properly at low temperatures. Check to see whether there is optimal operation even at low temperatures.



**Precautions  
for Correct Use**

♦ Use Cylindrical Servomotors in the ranges shown in the following graphs. Using outside of these ranges may cause the Servomotor to generate heat, which could result in encoder malfunction.

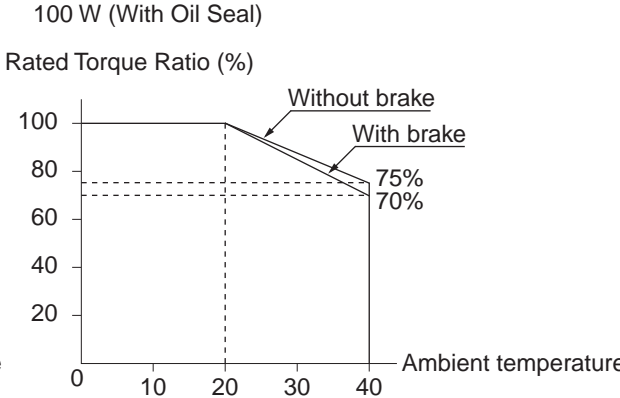
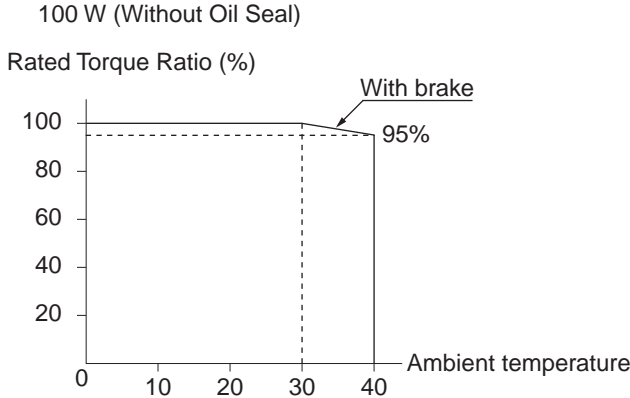
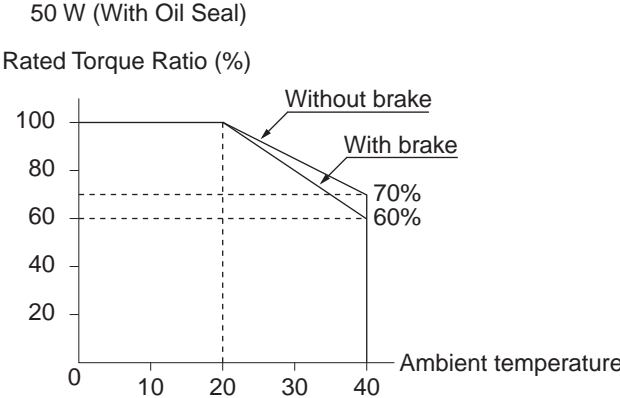
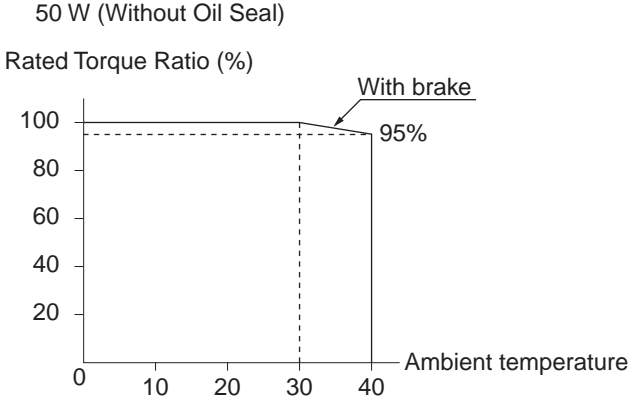

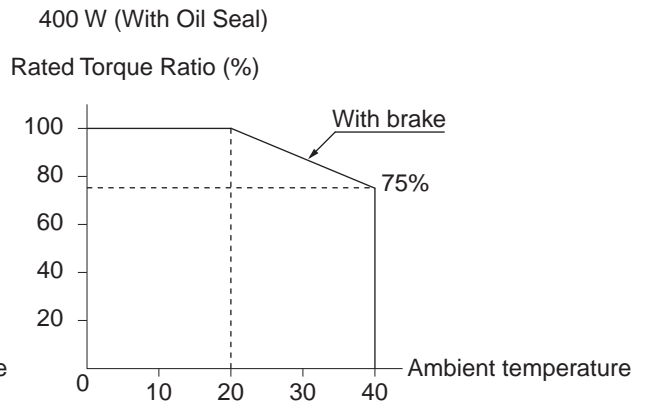
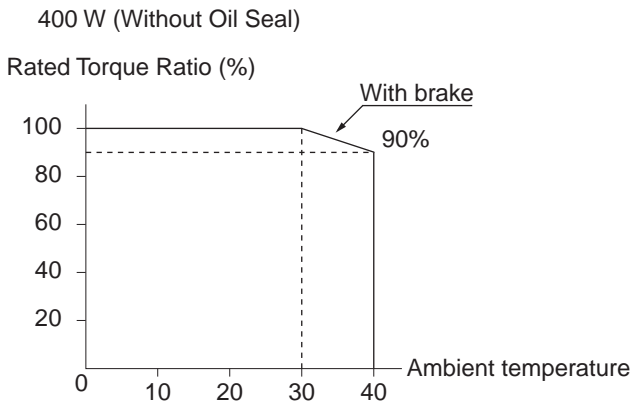
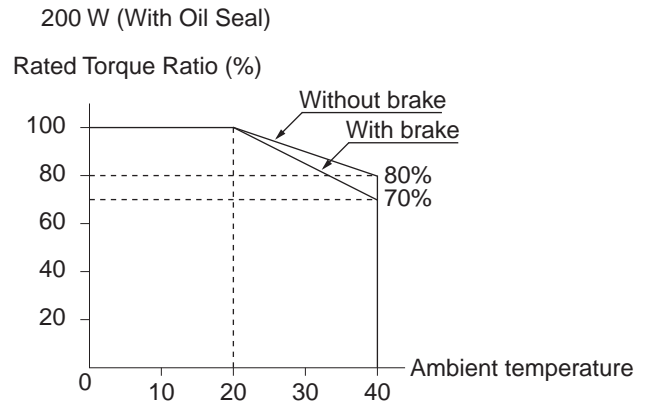

#### ■ Applicable Load Inertia

- ♦ The drivable load inertia ratio (load inertia/rotor inertia) depends on the configuration and rigidity of the machine being driven. Machines with high rigidity can be operated with a large load inertia. Select the appropriate Servomotor and confirm the applicable load inertia.
- ♦ Frequently operating a dynamic brake with a large load inertia may burn the dynamic brake resistor. Do not turn ON/OFF the Servomotor frequently with the dynamic brake enabled.

### Encoder Specifications

Item	Specifications
Encoder system	Optical encoder (incremental encoder)
No. of output pulses	Phases A and B: 2,500 pulses/rotation, Phase Z: 1 pulse/rotation
Power supply voltage	5 V $\pm$ 5%
Power supply current	180 mA (max.)
Output signals	+S, -S
Output interface	EIA-RS-485 compliance
	Bidirectional serial communications data

## 3-3 Decelerator Specifications

The following Decelerators are available for use with OMNUC G-Series Servomotors. Select a Decelerator matching the Servomotor capacity.

### Standard Models and Specifications

■ Backlash = 3' Max.

#### Decelerators for Cylindrical Servomotors

Model (R88G-)			Rated rotation speed	Rated torque	Efficiency	Maximum momentary rotation speed	Maximum momentary torque	Decelerator inertia	Allowable radial load	Allowable thrust load	Weight
			r/min	N·m	%	r/min	N·m	kg·m <sup>2</sup>	N	N	kg
50 W	1/5	HPG11A05100B	600	0.60	75	1000	1.80	$5.00 \times 10^{-7}$	135	538	0.29
	1/9	HPG11A09050B	333	1.17	81	555	3.51	$3.00 \times 10^{-7}$	161	642	0.29
	1/21	HPG14A21100B	143	2.18	65	238	6.54	$5.00 \times 10^{-6}$	340	1358	1.04
	1/33	HPG14A33050B	91	3.73	71	151	11.2	$4.40 \times 10^{-6}$	389	1555	1.04
	1/45	HPG14A45050B	67	5.09	71	111	15.2	$4.40 \times 10^{-6}$	427	1707	1.04
100 W	1/5	HPG11A05100B	600	1.37	86	1000	4.07	$5.00 \times 10^{-7}$	135	538	0.29
	1/11	HPG14A11100B	273	2.63	75	454	7.80	$6.00 \times 10^{-6}$	280	1119	1.04
	1/21	HPG14A21100B	143	5.40	80	238	16.0	$5.00 \times 10^{-6}$	340	1358	1.04
	1/33	HPG20A33100B	91	6.91	65	151	20.5	$6.50 \times 10^{-5}$	916	3226	2.4
	1/45	HPG20A45100B	67	9.42	65	111	27.9	$6.50 \times 10^{-5}$	1006	3541	2.4
200 W	1/5	HPG14A05200B	600	2.49	78	1000	7.44	$2.07 \times 10^{-5}$	221	883	1.02
	1/11	HPG14A11200B	273	6.01	85	454	17.9	$1.93 \times 10^{-5}$	280	1119	1.09
	1/21	HPG20A21200B	143	10.2	76	238	30.6	$4.90 \times 10^{-5}$	800	2817	2.9
	1/33	HPG20A33200B	91	17.0	81	151	50.8	$4.50 \times 10^{-5}$	916	3226	2.9
	1/45	HPG20A45200B	67	23.2	81	111	69.3	$4.50 \times 10^{-5}$	1006	3541	2.9
400 W	1/5	HPG14A05400B	600	5.66	87	1000	16.5	$2.07 \times 10^{-5}$	221	883	1.09
	1/11	HPG20A11400B	273	11.7	82	454	34.2	$5.70 \times 10^{-5}$	659	2320	2.9
	1/21	HPG20A21400B	143	23.5	86	238	68.8	$4.90 \times 10^{-5}$	800	2547	2.9
	1/33	HPG32A33400B	91	34.7	81	151	101.7	$6.20 \times 10^{-5}$	1565	6240	7.5
	1/45	HPG32A45400B	67	47.4	81	111	138.6	$6.10 \times 10^{-5}$	1718	6848	7.5

**Note 1.** The Decelerator inertia is the Servomotor shaft conversion value.

**Note 2.** The protective structure of Servomotors with Decelerators satisfies IP44.

**Note 3.** The allowable radial load is the value at the LR/2 position.

**Note 4.** The standard models have a straight shaft. Models with a key and tap are indicated by adding "J" to the end of the model number.

### 3-3 Decelerator Specifications

#### Decelerator for Flat Servomotors

Model (R88G-)		Rated rotation speed	Rated torque	Efficiency	Maximum momentary rotation speed	Maximum momentary torque	Decelerator inertia	Allowable radial load	Allowable thrust load	Weight	
		r/min	N·m	%	r/min	N·m	kg·m <sup>2</sup>	N	N	kg	
100 W	1/5	HPG11A05100PB	600	1.37	85	1000	3.84 (3.63)	5.00×10 <sup>-7</sup>	135	538	0.34
	1/11	HPG14A11100PB	273	2.63	75	454	7.39 (6.98)	6.00×10 <sup>-6</sup>	280	1119	1.04
	1/21	HPG14A21100PB	143	5.40	80	238	15.2 (14.6)	5.00×10 <sup>-6</sup>	340	1358	1.04
	1/33	HPG20A33100PB	91	6.91	65	151	19.4 (18.3)	4.50×10 <sup>-5</sup>	916	3226	2.9
	1/45	HPG20A45100PB	67	9.42	65	111	26.5 (25.0)	4.50×10 <sup>-5</sup>	1006	3541	2.9
200 W	1/5	HPG14A05200PB	600	2.49	78	1000	7.09	2.07×10 <sup>-5</sup>	221	883	0.99
	1/11	HPG20A11200PB	273	4.75	68	454	13.5	5.80×10 <sup>-5</sup>	659	2320	3.1
	1/21	HPG20A21200PB	143	10.2	76	238	29.2	4.90×10 <sup>-5</sup>	800	2817	3.1
	1/33	HPG20A33200PB	91	17.0	81	151	48.5	4.50×10 <sup>-5</sup>	916	3226	3.1
	1/45	HPG20A45200PB	67	23.2	81	111	66.1	4.50×10 <sup>-5</sup>	1006	3541	3.1
400 W	1/5	HPG20A05400PB	600	4.67	72	1000 (900)	12.9	7.10×10 <sup>-5</sup>	520	1832	3.1
	1/11	HPG20A11400PB	273	11.7	82	454 (409)	32.4	5.80×10 <sup>-5</sup>	659	2320	3.1
	1/21	HPG20A21400PB	143	23.5	86	238 (214)	65.2	4.90×10 <sup>-5</sup>	800	2817	3.1
	1/33	HPG32A33400PB	91	34.7	81	151 (136)	96.2	2.80×10 <sup>-4</sup>	1565	6240	7.8
	1/45	HPG32A45400PB	67	47.4	81	111 (100)	131.2	2.80×10 <sup>-4</sup>	1718	6848	7.8

**Note 1.** The Decelerator inertia is the Servomotor shaft conversion value.

**Note 2.** The protective structure of Servomotors with Decelerators satisfies IP44.

**Note 3.** The allowable radial load is the value at the LR/2 position.

**Note 4.** The standard models have a straight shaft. Models with a key and tap are indicated by adding "J" to the end of the model number.

**Note 5.** The values in parentheses ( ) are those when using a 100-V motor.

■ Backlash = 15' Max.

#### Decelerators for Cylindrical Servomotors

Model (R88G-)		Rated rotation speed	Rated torque	Efficiency	Maximum momentary rotation speed	Maximum momentary torque	Decelerator inertia	Allowable radial load	Allowable thrust load	Weight	
		r/min	N·m	%	r/min	N·m	kg·m <sup>2</sup>	N	N	kg	
50 W	1/5	VRSF05B100CJ	600	0.52	65	1000	1.55	4.00×10 <sup>-6</sup>	392	196	0.55
	1/9	VRSF09B100CJ	333	0.93	65	556	2.79	3.50×10 <sup>-6</sup>	441	220	0.55
	1/15	VRSF15B100CJ	200	1.67	70	333	5.01	3.50×10 <sup>-6</sup>	588	294	0.70
	1/25	VRSF25B100CJ	120	2.78	70	200	8.34	3.25×10 <sup>-6</sup>	686	343	0.70
100 W	1/5	VRSF05B100CJ	600	1.19	75	1000	3.57	4.00×10 <sup>-6</sup>	392	196	0.55
	1/9	VRSF09B100CJ	333	2.29	80	556	6.87	3.50×10 <sup>-6</sup>	441	220	0.55
	1/15	VRSF15B100CJ	200	3.81	80	333	11.4	3.50×10 <sup>-6</sup>	588	294	0.70
	1/25	VRSF25B100CJ	120	6.36	80	200	19.0	3.25×10 <sup>-6</sup>	686	343	0.70
200 W	1/5	VRSF05B200CJ	600	2.70	85	1000	8.10	1.18×10 <sup>-5</sup>	392	196	0.72
	1/9	VRSF09C200CJ	333	3.77	66	556	11.3	2.75×10 <sup>-5</sup>	931	465	1.70
	1/15	VRSF15C200CJ	200	6.29	66	333	18.8	3.00×10 <sup>-5</sup>	1176	588	2.10
	1/25	VRSF25C200CJ	120	11.1	70	200	33.3	2.88×10 <sup>-5</sup>	1323	661	2.10
400 W	1/5	VRSF05C400CJ	600	5.40	85	1000	16.2	3.63×10 <sup>-5</sup>	784	392	1.70
	1/9	VRSF09C400CJ	333	9.50	83	556	28.5	2.75×10 <sup>-5</sup>	931	465	1.70
	1/15	VRSF15C400CJ	200	15.8	83	333	47.4	3.00×10 <sup>-5</sup>	1176	588	2.10
	1/25	VRSF25C400CJ	120	26.4	83	200	79.2	2.88×10 <sup>-5</sup>	1323	661	2.10

**Note 1.** The Decelerator inertia is the Servomotor shaft conversion value.

**Note 2.** The protective structure of Servomotors with Decelerators satisfies IP44.

**Note 3.** The allowable radial load is the value at the LR/2 position.

**Note 4.** The standard models have a straight shaft.

### 3-3 Decelerator Specifications

#### Decelerator for Flat Servomotors

Model (R88G-)		Rated rotation speed	Rated torque	Efficiency	Maximum momentary rotation speed	Maximum momentary torque	Decelerator inertia	Allowable radial load	Allowable thrust load	Weight	
		r/min	N·m	%	r/min	N·m	kg·m <sup>2</sup>	N	N	kg	
100 W	1/5	VRSF05B100PCJ	600	1.19	75	1000	3.38 (3.19)	4.00×10 <sup>-6</sup>	392	196	0.72
	1/9	VRSF09B100PCJ	333	2.29	80	556	6.48 (6.12)	3.50×10 <sup>-6</sup>	441	220	0.72
	1/15	VRSF15B100PCJ	200	3.81	80	333	10.8 (10.2)	3.50×10 <sup>-6</sup>	588	294	0.87
	1/25	VRSF25B100PCJ	120	6.36	80	200	18.0 (17.0)	3.25×10 <sup>-6</sup>	686	343	0.87
200 W	1/5	VRSF05B200PCJ	600	2.70	85	1000	7.74	1.18×10 <sup>-5</sup>	392	196	0.85
	1/9	VRSF09C200PCJ	333	3.77	66	556	10.8	2.75×10 <sup>-5</sup>	931	465	1.80
	1/15	VRSF15C200PCJ	200	6.29	66	333	18.0	3.00×10 <sup>-5</sup>	1176	588	2.20
	1/25	VRSF25C200PCJ	120	11.1	70	200	31.8	2.88×10 <sup>-5</sup>	1323	661	2.20
400 W	1/5	VRSF05C400PCJ	600	5.40	85	1000 (900)	15.3	3.63×10 <sup>-5</sup>	784	392	1.80
	1/9	VRSF09C400PCJ	333	9.50	83	556 (500)	26.9	2.75×10 <sup>-5</sup>	931	465	1.80
	1/15	VRSF15C400PCJ	200	15.8	83	333 (300)	44.8	3.00×10 <sup>-5</sup>	1176	588	2.20
	1/25	VRSF25C400PCJ	120	26.4	83	200 (180)	74.7	2.88×10 <sup>-5</sup>	1323	661	2.20

**Note 1.** The Decelerator inertia is the Servomotor shaft conversion value.

**Note 2.** The protective structure of Servomotors with Decelerators satisfies IP44.

**Note 3.** The allowable radial load is the value at the LR/2 position.

**Note 4.** The standard models have a straight shaft.

**Note 5.** The values in parentheses ( ) are those when using a 100-V motor.

# 3-4 Cable and Connector Specifications

## Encoder Cable Specifications

These cables are used to connect the encoder between the Servo Drive and Servomotor. Encoder Cables with connectors for CN2 are available.

**Precautions for Correct Use**

♦ Use robot cables for applications with moving parts.

### Standard Cables for Encoders

#### Cable Models

Model	Length (L) <sup>*1</sup>	Outer diameter of sheath	Weight
R88A-CRGB003C	3 m	6.5 dia.	Approx. 0.2 kg
R88A-CRGB005C	5 m		Approx. 0.3 kg
R88A-CRGB010C	10 m		Approx. 0.6 kg
R88A-CRGB015C	15 m		Approx. 0.9 kg
R88A-CRGB020C	20 m		Approx. 1.2 kg

\*1. The maximum distance between the Servo Drive and Servomotor is 20 m.

#### Connection Configuration and External Dimensions

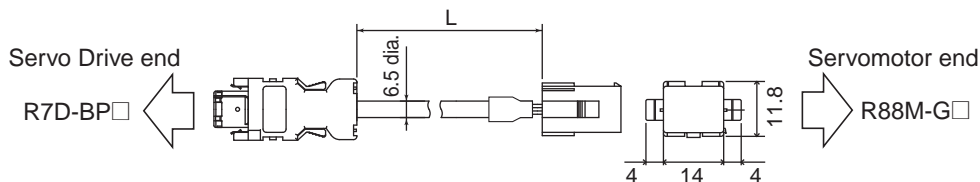

#### Wiring

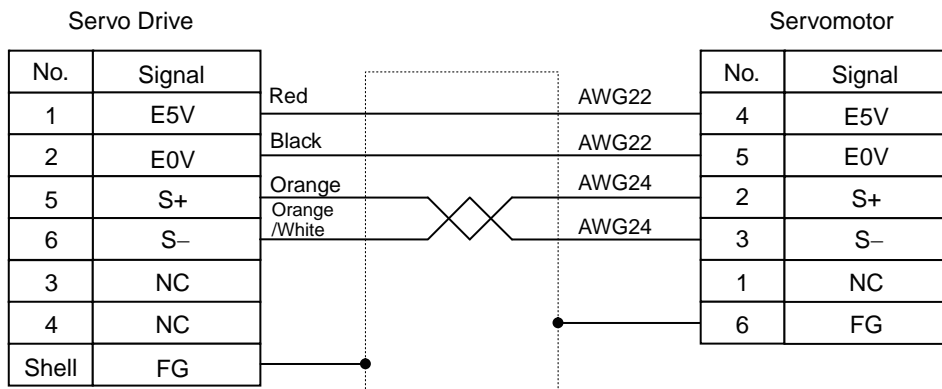

Servo Drive Connector  
 Connector pins:  
 50639-8028 (Molex Japan)  
 Connector case:  
 Crimp-type I/O Connector (Molex Japan)

Servomotor Connector  
 Connector pins:  
 170365-1 (Tyco Electronics AMP KK)  
 Connector case:  
 172160-1 (Tyco Electronics AMP KK)

### 3-4 Cable and Connector Specifications

#### ■ Robot Cables for Encoders

##### Cable Models

Model	Length (L) <sup>*1</sup>	Outer diameter of sheath	Weight
R88A-CRGB003CR	3 m	7.5 dia.	Approx. 0.2 kg
R88A-CRGB005CR	5 m		Approx. 0.4 kg
R88A-CRGB010CR	10 m		Approx. 0.8 kg
R88A-CRGB015CR	15 m		Approx. 1.1 kg
R88A-CRGB020CR	20 m		Approx. 1.5 kg

\*1. The maximum distance between the Servo Drive and Servomotor is 20 m.

##### Connection Configuration and External Dimensions

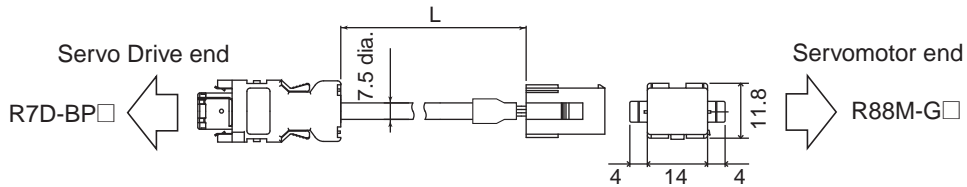

##### Wiring

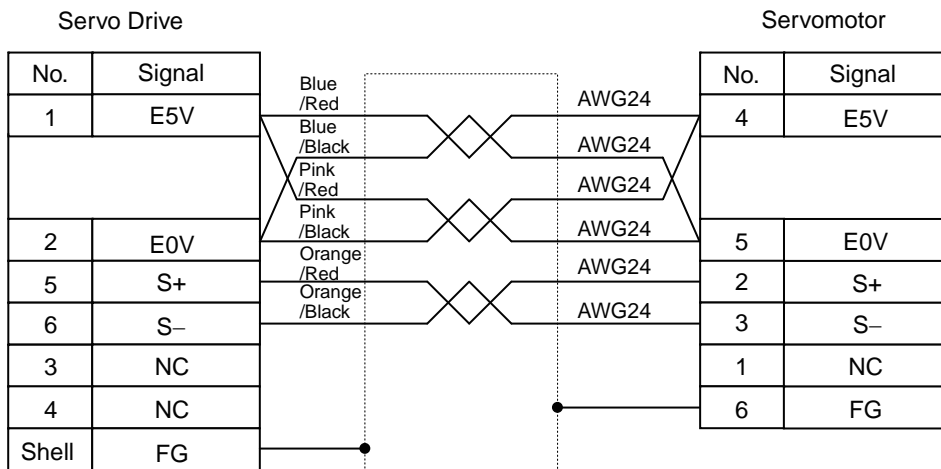

Servo Drive Connector  
 Connector pins:  
 50639-8028 (Molex Japan)  
 Connector case:  
 Crimp-type I/O Connector (Molex Japan)

Servomotor Connector  
 Connector pins:  
 170365-1 (Tyco Electronics AMP KK)  
 Connector case:  
 172160-1 (Tyco Electronics AMP KK)



## Servomotor Power Cable Specifications

These are the cables connecting between the Servo Drive and Servomotor. Servomotor Power Cables with connectors for the CNB are available. When using Cables for a Servomotor with a brake, a Brake Cable is also required. Brake cables are also available as standard cables and robot cables.

**Precautions for Correct Use**

◆ Use robot cables for applications with moving parts.

### ■ Standard Cables for Servomotor Power (with CNB Connector)

#### Cable Models

Model	Length (L) <sup>*1</sup>	Outer diameter of sheath	Weight
R7A-CAB003S	3 m	6.2 dia.	Approx. 0.2 kg
R7A-CAB005S	5 m		Approx. 0.3 kg
R7A-CAB010S	10 m		Approx. 0.6 kg
R7A-CAB015S	15 m		Approx. 0.9 kg
R7A-CAB020S	20 m		Approx. 1.2 kg

\*1. The maximum distance between the Servo Drive and Servomotor is 20 m.

#### Connection Configuration and External Dimensions

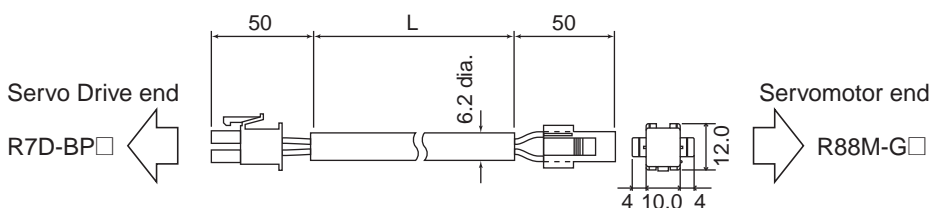

#### Wiring

Servo Drive		Servomotor	
No.	Signal	No.	Signal
1	Phase-U	1	Phase-U
4	Phase-V	2	Phase-V
6	Phase-W	3	Phase-W
3	FG	4	FG
2			
5			

Cable: AWG20 × 4C UL2464

#### Servo Drive Connector

Connector pins:  
5556PBTL (Molex Japan)  
Connector case:  
5557-06R-210 (Molex Japan)

#### Servomotor Connector

Connector pins:  
170366-1 or 170362-1  
(Tyco Electronics AMP KK)  
Connector case:  
172159-1 (Tyco Electronics AMP KK)

### 3-4 Cable and Connector Specifications

#### ■ Robot Cables for Servomotor Power (with CNB Connector)

##### Cable Models

Model	Length (L) <sup>*1</sup>	Outer diameter of sheath	Weight
R7A-CAB003SR	3 m	6.9 dia.	Approx. 0.2 kg
R7A-CAB005SR	5 m		Approx. 0.3 kg
R7A-CAB010SR	10 m		Approx. 0.7 kg
R7A-CAB015SR	15 m		Approx. 1.0 kg
R7A-CAB020SR	20 m		Approx. 1.3 kg

\*1. The maximum distance between the Servo Drive and Servomotor is 20 m.

##### Connection Configuration and External Dimensions

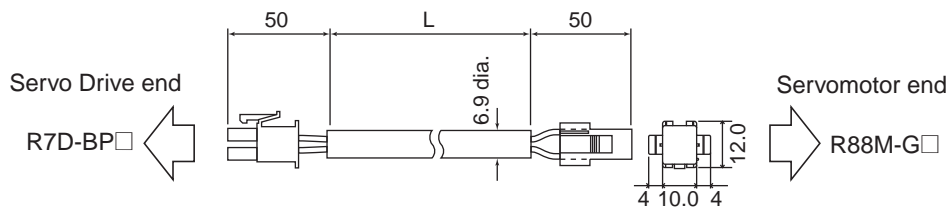

##### Wiring

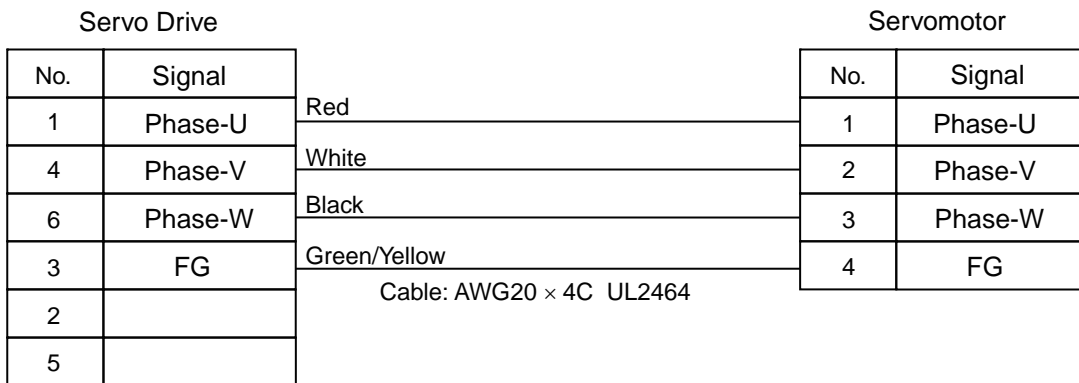

##### Servo Drive Connector

Connector pins:  
5556PBTL (Molex Japan)  
Connector case:  
5557-06R-210 (Molex Japan)

##### Servomotor Connector

Connector pins:  
170366-1 or 170362-1  
(Tyco Electronics AMP KK)  
Connector case:  
172159-1 (Tyco Electronics AMP KK)

■ Standard Cables for Brakes

Cable Models

Model	Length (L) <sup>*1</sup>	Outer diameter of sheath	Weight
R88A-CAGA003B	3 m	5.4 dia.	Approx. 0.1 kg
R88A-CAGA005B	5 m		Approx. 0.2 kg
R88A-CAGA010B	10 m		Approx. 0.4 kg
R88A-CAGA015B	15 m		Approx. 0.6 kg
R88A-CAGA020B	20 m		Approx. 0.8 kg

\*1. The maximum distance between the Servo Drive and Servomotor is 20 m.

Connection Configuration and External Dimensions

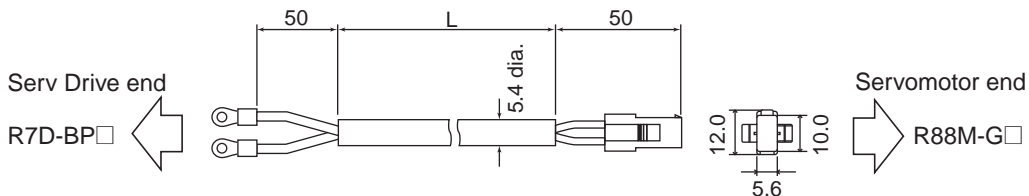

Wiring

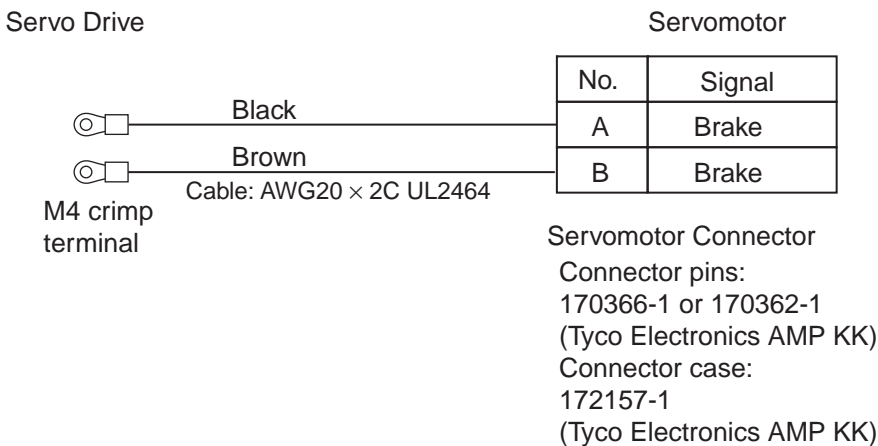

#### ■ Robot Cables for Brakes

##### Cable Models

Model	Length (L) <sup>*1</sup>	Outer diameter of sheath	Weight
R88A-CAGA003BR	3 m	6.1 dia.	Approx. 0.1 kg
R88A-CAGA005BR	5 m		Approx. 0.2 kg
R88A-CAGA010BR	10 m		Approx. 0.4 kg
R88A-CAGA015BR	15 m		Approx. 0.7 kg
R88A-CAGA020BR	20 m		Approx. 0.9 kg

\*1. The maximum distance between the Servo Drive and Servomotor is 20 m.

##### Connection Configuration and External Dimensions

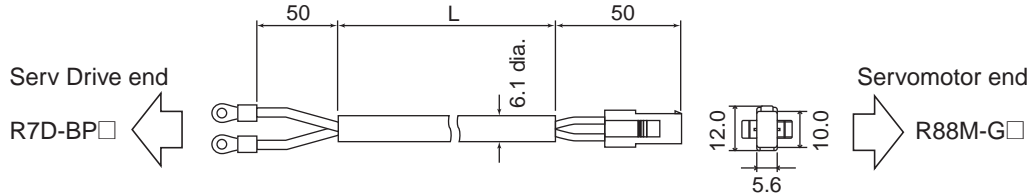

##### Wiring

Servo Drive

Servomotor

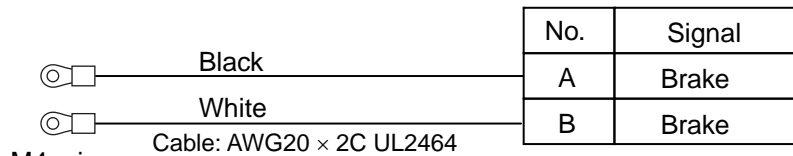

Servomotor Connector

Connector pins:

170366-1 or 170362-1

(Tyco Electronics AMP KK)

Connector case:

172157-1

(Tyco Electronics AMP KK)

## Power Cable Specifications

This is the Cable that supplies power to the Servo Drive.  
 Power Cables are available in two forms: single-phase and three-phase. Select the Cable matching the Servo Drive to be used.  
 When connecting an External Regeneration Resistor, use an External Regeneration Resistor Cable.

### ■ Single-phase Power Cable (with CNA Connector)

#### Cable Models

Model	Length (L)	Outer diameter of sheath	Weight
R7A-CLB002S2	2 m	6.1 dia.	Approx. 0.1 kg

#### Connection Configuration and External Dimensions

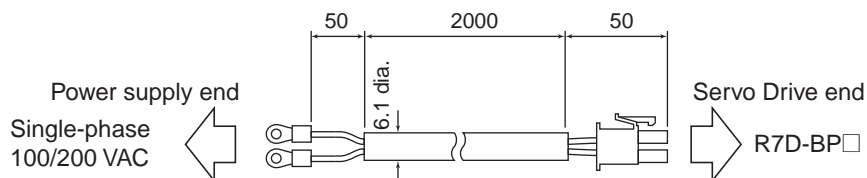

#### Wiring

Power supply end

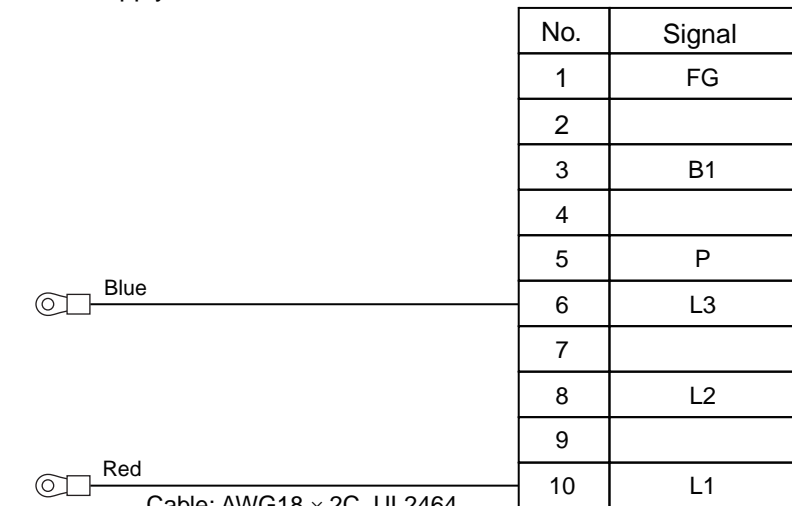

M4 crimp terminal

Servo Drive Connector  
 Connector pins:  
 5556PBTL (Molex Japan)  
 Connector case:  
 5557-10R-210 (Molex Japan)

### 3-4 Cable and Connector Specifications

#### ■ Three-phase Power Cable (with CNA Connector)

##### Cable Models

Model	Length (L)	Outer diameter of sheath	Weight
R7A-CLB002S3	2 m	6.4 dia.	Approx. 0.1 kg

##### Connection Configuration and External Dimensions

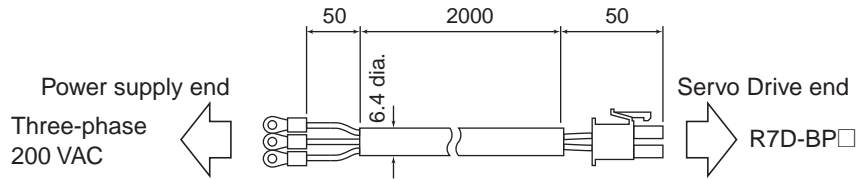

##### Wiring

Power supply end

Servo Drive

No.	Signal
1	FG
2	
3	B1
4	
5	P
6	L3
7	
8	L2
9	
10	L1

Blue

White

Red

Cable: AWG18 × 3C UL2464

M4 crimp terminal

Servo Drive Connector

Connector pins:  
5556PBTL (Molex Japan)

Connector case:  
5557-10R-210 (Molex Japan)

■ External Regeneration Resistor Connection Cable (with Crimp Pins)

Cable Models

Model	Length (L)	Outer diameter of sheath	Weight
R7A-CLB002RG	2 m	6.1 dia.	Approx. 0.1 kg

Connection Configuration and External Dimensions

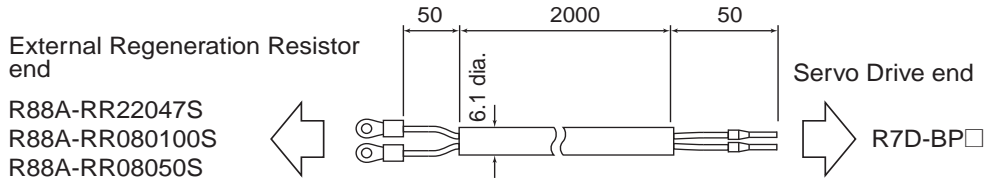

Wiring

Insert into the P (pin 5) and B1 (pin 3) slots of the Main Circuit Connector (CNA).

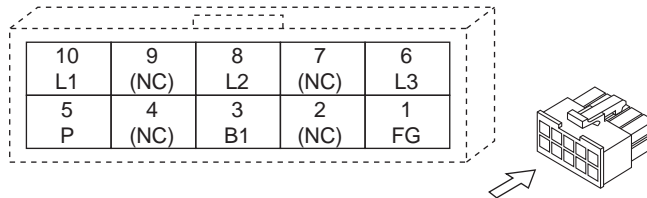

## Communications Cable Specifications

### ■ Personal Computer Monitor Cable

#### Cable Models

Model	Length (L)	Outer diameter of sheath	Weight
R88A-CCG002P2	2 m	4.2 dia.	Approx. 0.1 kg

#### Connection Configuration and External Dimensions

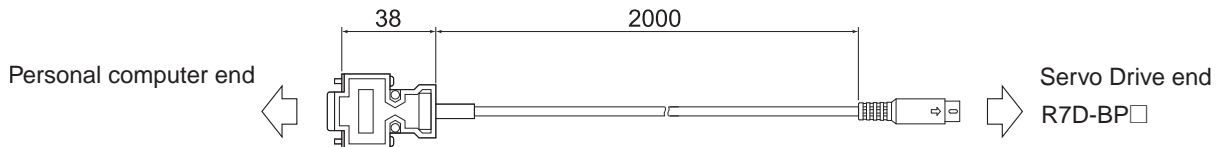

#### Wiring

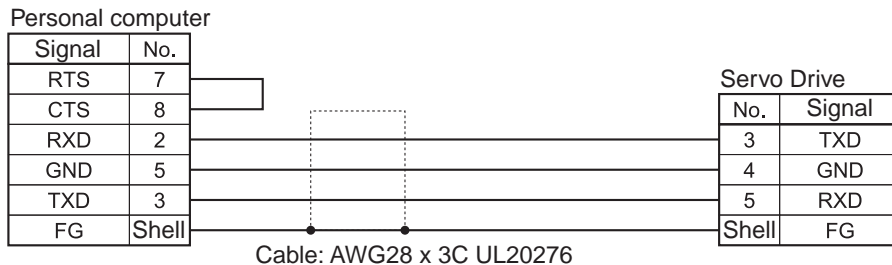

PC Connector  
17JE-13090-02 (D8A) (DDK Ltd.)

#### Precautions for Correct Use

- ◆ Communications with the Host Device  
After confirming the startup of the Servo Drive, initiate communications with the host device.  
Note that irregular signals may be received from the host interface during startup. For this reason, take appropriate initialization measures such as clearing the receive buffer.



### Connector Specifications

#### ■ Main Circuit Connector (R7A-CNB01P)

The Main Circuit Connector connects to the Servo Drive's Main Circuit Connector (CNA).

#### Dimensions

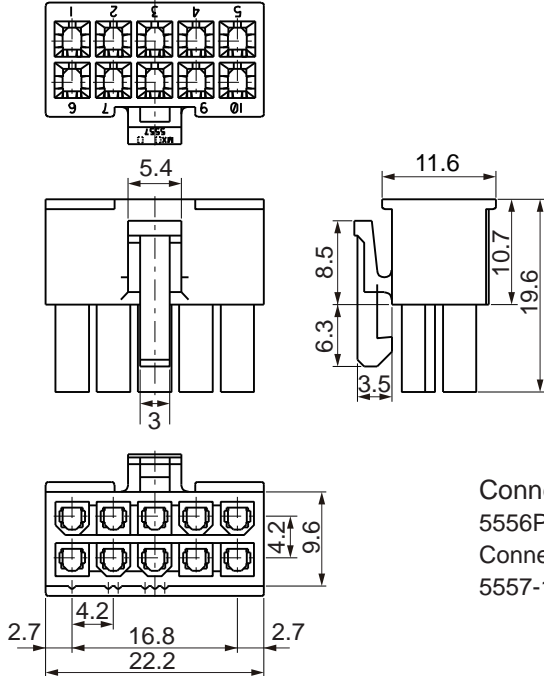

Connector pins:  
 5556PBTL (Molex Japan)  
 Connector case:  
 5557-10R-210 (Molex Japan)

### 3-4 Cable and Connector Specifications

#### ■ Servomotor Connector (R7A-CNB01A)

The Servomotor Connector connects to the Servo Drive's Servomotor Connector (CNB).

##### Dimensions

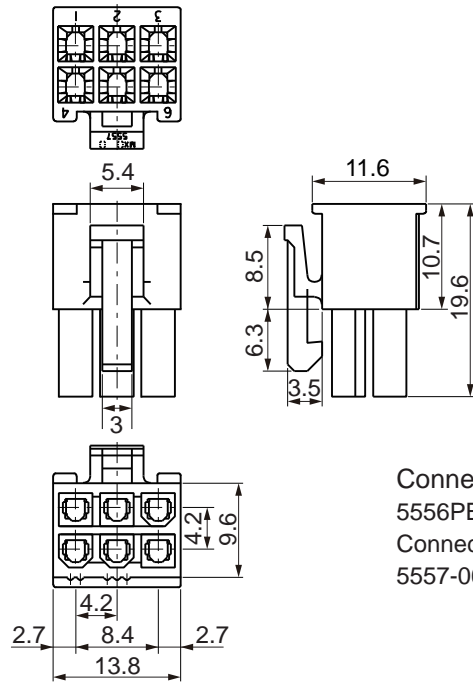

Connector pins:  
5556PBTL (Molex Japan)  
Connector case:  
5557-06R-210 (Molex Japan)

#### ■ Control I/O Connector (R88A-CNW01C)

This Connector connects to the Control I/O Connector (CN1) of the Servo Drive.  
Use this Connector when preparing a control cable yourself.

##### Dimensions

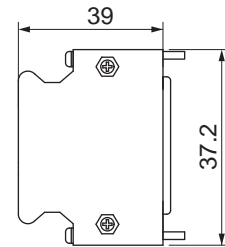

Connector plug:  
10126-3000PE (Sumitomo 3M)  
Connector case:  
10326-52A0-008 (Sumitomo 3M)

■ Encoder Connectors

These Connectors are used for Encoder Cables.  
Use them when preparing an encoder cable yourself.

**R88A-CNW01R (CN2 Servo Drive Connector)**

This connector is soldering type.  
Use the following cable.

- ◆ Applicable wire: AWG16 max.
- ◆ Insulating cover outer diameter: 2.1 mm max.
- ◆ Sheath outer diameter: 6.7±0.5 mm

Dimensions

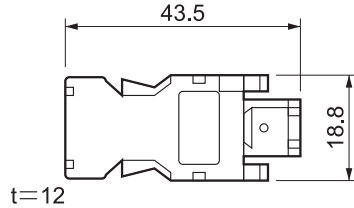

Connector plug:  
55100-0670 (Molex Japan Co.)

**R88A-CNG02R (Servomotor Connector)**

Use the following cable.

- ◆ Applicable wire: AWG22 max.
- ◆ Insulating cover outer diameter: 1.75 mm max.

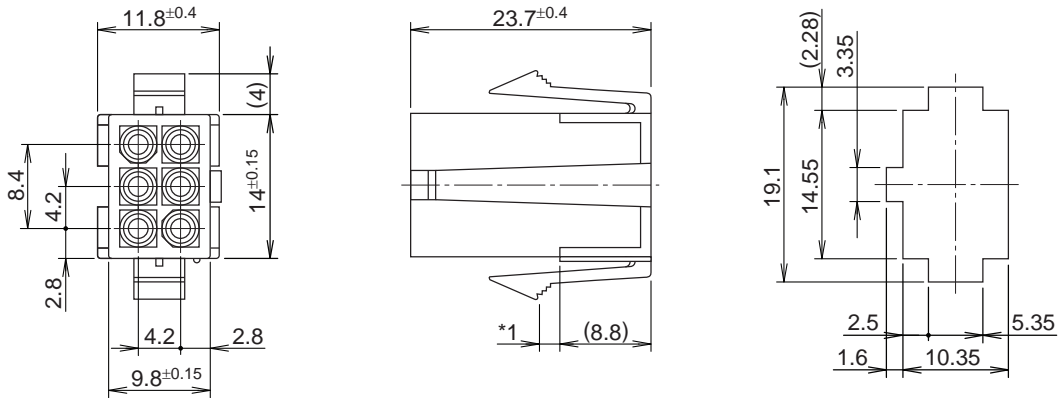

- ◆ Connector housing: 172160-1 (Tyco Electronics AMP KK)
- ◆ Contact socket: 170365-1 (Tyco Electronics AMP KK)
- ◆ Applicable panel thickness: 0.8 to 2.0 mm

### 3-4 Cable and Connector Specifications

#### ■ Power Cable Connector (R88A-CNG01A)

This Connector is used for Power Cables.  
Use it when preparing a power cable yourself.

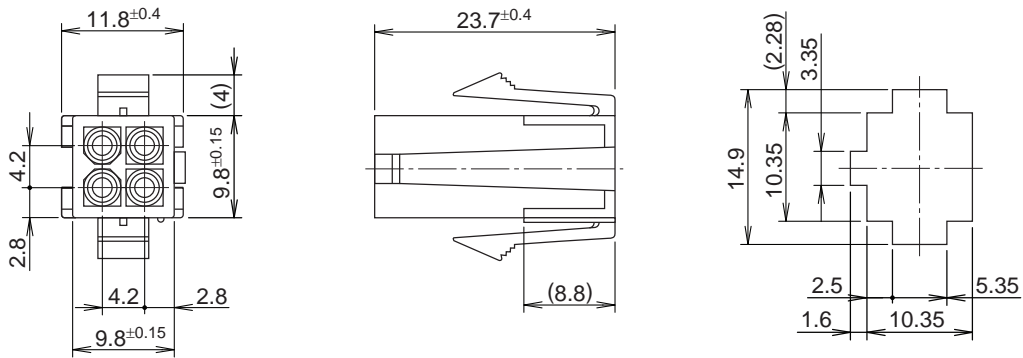

- ♦ Connector housing: 172159-1 (Tyco Electronics AMP KK)
- ♦ Contact socket: 170366-1 (Tyco Electronics AMP KK)
- ♦ Applicable panel thickness: 0.8 to 2.0 mm

#### ■ Brake Cable Connector (R88A-CNG01B)

This Connector is used for brake cables.  
Use it when preparing a brake cable yourself.

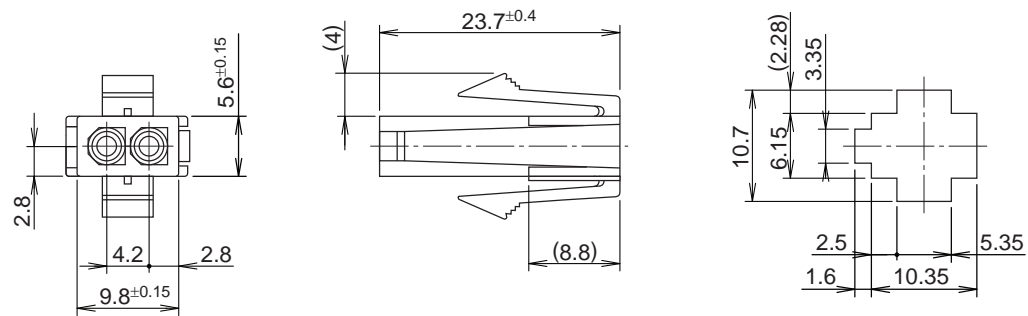

- ♦ Connector housing: 172157-1 (Tyco Electronics AMP KK)
- ♦ Contact socket: 170366-1 (Tyco Electronics AMP KK)
- ♦ Applicable panel thickness: 0.8 to 2.0 mm

## Control Cable Specifications

### ■ General-purpose Control Cables

A General-purpose Control Cable connects to the Servo Drive's Control I/O Connector (CN1). Do not wire the pins that have no signals allocated.

#### Cable Models

Model	Length (L)	Outer diameter of sheath	Weight
R7A-CPB001S	1 m	9.5 dia.	Approx. 0.2 kg
R7A-CPB002S	2 m		Approx. 0.3 kg

#### Connection Configuration and External Dimensions

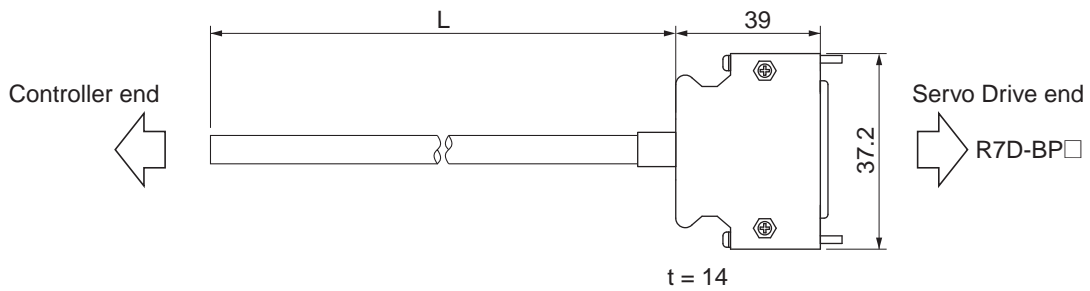

### 3-4 Cable and Connector Specifications

#### Wiring

No.	Wire color (mark color)	Signal
1	Orange (Red 1)	+24VIN
2	Orange (Black 1)	RUN
3	Gray (Red 1)	RESET
4	Gray (Black 1)	ECRST/VSEL2
5	White (Red 1)	GSEL/VZERO/TLSEL
6	White (Black 1)	GESEL/VSEL1
7	Yellow (Red 1)	NOT
8	Yellow (Black 1)	POT
9	Pink (Red 1)	/ALM
10	Pink (Black 1)	INP/TGON
11	Orange (Red 2)	BKIR
12	Orange (Black 2)	WARN
13	Gray (Red 2)	OGND
14	Gray (Black 2)	GND
15	White (Red 2)	+A
16	White (Black 2)	-A
17	Yellow (Black 2)	-B
18	Yellow (Red 2)	+B
19	Pink (Red 2)	+Z
20	Pink (Black 2)	-Z
21	Orange (Red 3)	Z
22	Gray (Red 3)	+CW/+PULS/+FA
23	Gray (Black 3)	-CW/-PULS/-FA
24	White (Red 3)	+CCW/+SIGN/+FB
25	White (Black 3)	-CCW/-SIGN/-FB
26	Orange (Black 3)	FG

Connector plug: 10126-3000PE (Sumitomo 3M)

Connector case: 10326-52A0-008 (Sumitomo 3M)

Cable: AWG24 × 13P UL20276

Wires with the same wire color and number of marks form a twisted pair.

#### Pin Arrangement

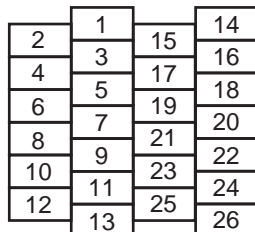

■ Connector Terminal Block Cables (XW2Z-□□□J-B28)

This Cable is for the Connector Terminal Block of the Servo Drive's Control I/O Connector (CN1).

Cable Models

Model	Length (L)	Outer diameter of sheath	Weight
XW2Z-100J-B28	1 m	9.1 dia.	Approx. 0.1 kg
XW2Z-200J-B28	2 m		Approx. 0.2 kg

Connection Configuration and External Dimensions

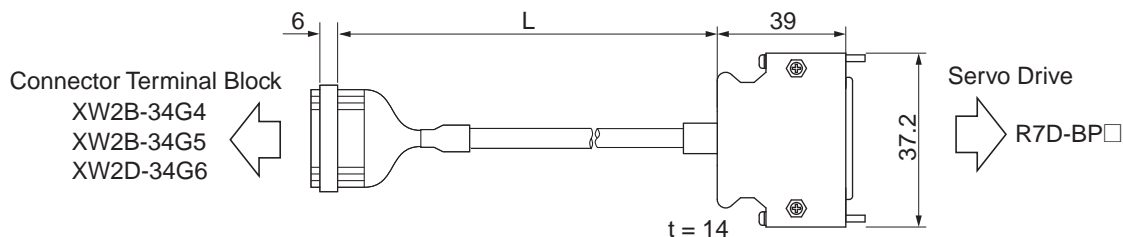

Wiring

Terminal Block		Connector		Servo Drive		
Signal	No.	No.		No.	Wire/mark color	Signal
+24VIN	1	1		1	Blue/Red (1)	+24VIN
RUN	2	2		2	Blue/Black (1)	RUN
RESET	3	3		3	Pink/Red (1)	RESET
ECRST/VSEL2	4	4		4	Pink/Black (1)	ECRST/VSEL2
GSEL/ZERO/TLSEL	5	5		5	Green/Red (1)	GSEL/ZERO/TLSEL
SESEL/VSEL1	6	6		6	Green/Black (1)	SESEL/VSEL1
NOT	7	7		7	Orange/Red (1)	NOT
POT	8	8		8	Orange/Black (1)	POT
/ALM	9	9		9	Gray/Red (1)	/ALM
INP/TGON	10	10		10	Gray/Black (1)	INP/TGON
BKIR	11	11		11	Blue/Red (2)	BKIR
WARN	12	12		12	Blue/Black (2)	WARN
OGND	13	13		13	Pink/Red (2)	OGND
GND	14	14		14	Pink/Black (2)	GND
+A	15	15		15	Green/Red (2)	+A
-A	16	16		16	Green/Black (2)	-A
-B	17	17		17	Orange/Red (2)	-B
+B	18	18		18	Orange/Black (2)	+B
+Z	19	19		19	Gray/Red (2)	+Z
-Z	20	20		20	Gray/Black (2)	-Z
+CW/+PULS/+FA	22	22		22	Blue/Red (3)	+CW/+PULS/+FA
-CW/-PULS/-FA	23	23		23	Blue/Black (3)	-CW/-PULS/-FA
+CCW/+SIGN/+FB	24	24		24	Pink/Red (3)	+CCW/+SIGN/+FB
-CCW/-SIGN/-FB	25	25		25	Pink/Black (3)	-CCW/-SIGN/-FB
Z	21	21		21	Green/Red (3)	Z
FG	26	26		26	Green/Black (3)	FG
	27	27				
	28	28				
	29	29				
	30	30				
	31	31				
	32	32				
	33	33				
	34	34				

- Terminal Block Connector
- Connector socket: XG4M-3430
- Strain relief: XG4T-3404
- Cable
- AWG28 × 13P UL2464
- Servo Drive Connector
- Connector plug: 10126-3000PE (Sumitomo 3M)
- Connector case: 10326-52A0-008 (Sumitomo 3M)

#### ■ Connector-Terminal Block Conversion Unit

By using the Connector-Terminal Block Conversion Unit in combination with a Connector Terminal Block Cable (XW2Z-□J-B28), the Servo Drive's Control I/O Connector (CN1) can be converted to a terminal block.

#### XW2B-34G4 (M3 screw terminal block)

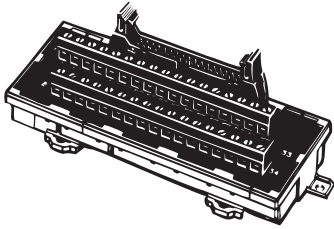

◆ Dimensions

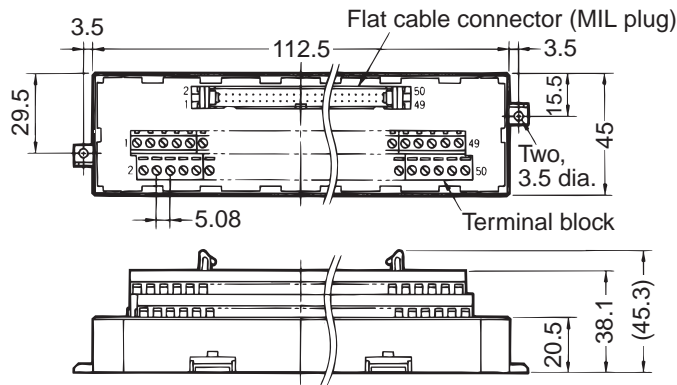

#### Precautions for Correct Use

- ◆ Use 0.30 to 1.25 mm<sup>2</sup> wire (AWG22 to AWG16).
- ◆ The wire slot is 1.8 mm (height) × 2.5 mm (width).
- ◆ Strip the insulation from the end of the wire for 6 mm as shown below.

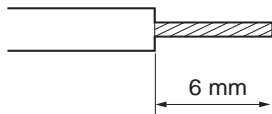



XW2B-34G5 (M3.5 screw terminal block)

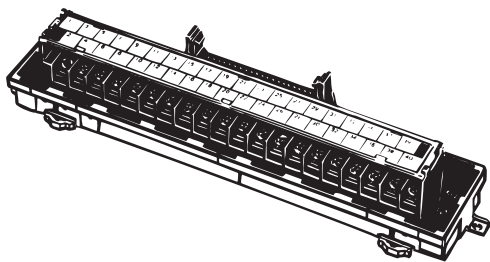

◆ Dimensions

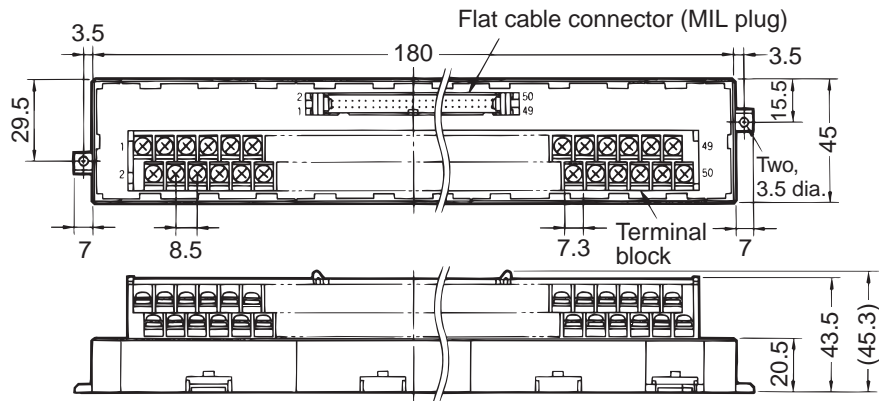

**Precautions for Correct Use**

- ◆ When using crimp terminals, use crimp terminals with the following dimensions.
- ◆ When connecting wires and crimp terminals to a Terminal Block, tighten them with a tightening torque of 0.59 N·m.

Round Crimp Terminals

Fork Terminals

3.7-mm dia.



Applicable Crimp Terminals		Applicable Wires
Round Crimp Terminals	1.25 to 3	AWG22 to AWG16 (0.3 to 1.25 mm <sup>2</sup> )
	2 to 3.5	AWG16 to AWG14 (1.25 to 2.0 mm <sup>2</sup> )
Fork Terminals	1.25Y to 3	AWG22 to AWG16 (0.3 to 1.25 mm <sup>2</sup> )
	2 to 3.5	AWG16 to AWG14 (1.25 to 2.0 mm <sup>2</sup> )



### 3-4 Cable and Connector Specifications

#### XW2D-34G6 (M3 screw terminal block)

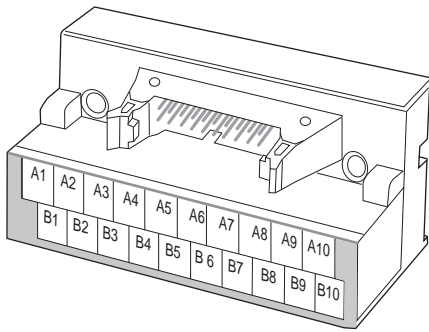

◆ Dimensions

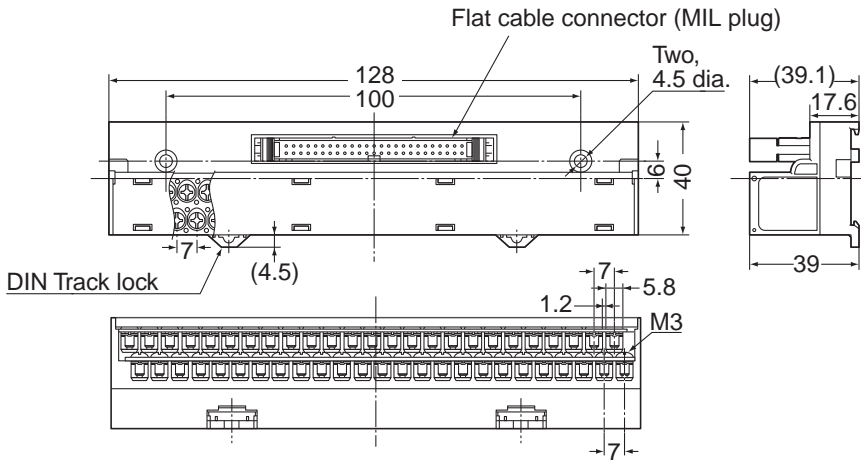

**Precautions for Correct Use**

- ◆ When using crimp terminals, use crimp terminals with the following dimensions.
- ◆ When connecting wires and crimp terminals to a Terminal Block, tighten them with a tightening torque of 0.7 N·m.

Round Crimp Terminals

Fork Terminals

3.2-mm dia.

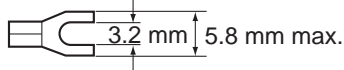
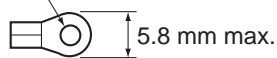

Applicable Crimp Terminals		Applicable Wires
Round Crimp Terminals	1.25 to 3	AWG22 to 16 (0.3 to 1.25 mm <sup>2</sup> )
Fork Terminals	1.25Y to 3	AWG22 to 16 (0.3 to 1.25 mm <sup>2</sup> )

**Terminal Block Wiring Example (for XW2B-34G4, XW2B-34G5, and XW2D-34G6)**

◆ Line-driver Connections

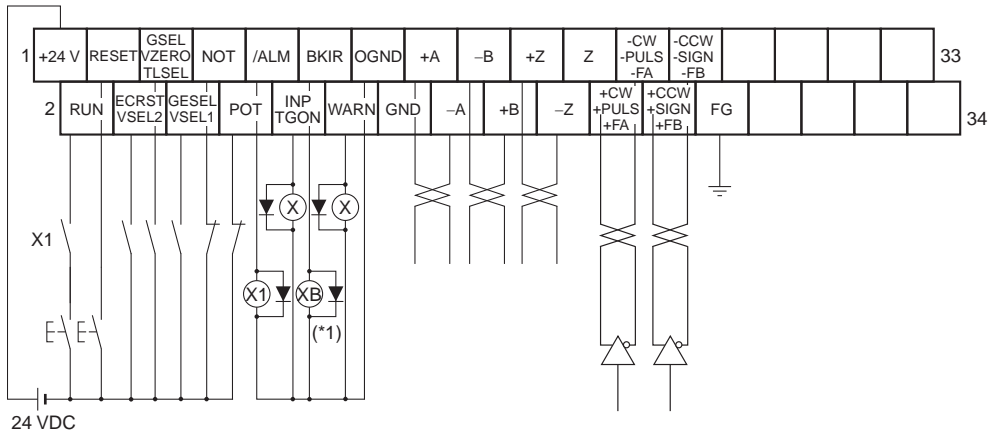

\*1. The XB contacts are used to turn the electromagnetic brake ON and OFF.

◆ Open-collector Connections

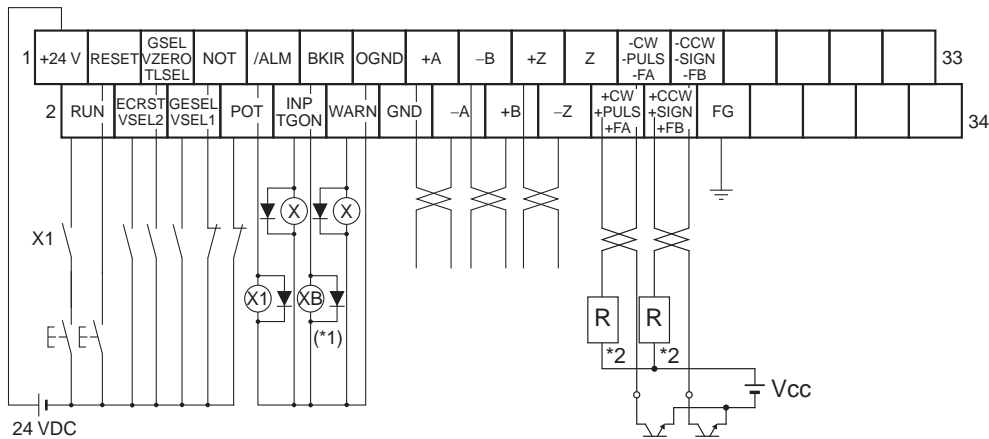

\*1. The XB contacts are used to turn the electromagnetic brake ON and OFF.

\*2. Select a value for resistance R so that the input current will be from 7 to 15 mA. (Refer to the following table.)

Vcc	R
24 V	2 kΩ
12 V	1 kΩ

Terminal Block Signal Names

No.	Signal
1	+24VIN
2	RUN
3	RESET
4	ECRST/VSEL2
5	GSEL/VZERO/TLSEL
6	SESEL/VSEL1
7	NOT
8	POT
9	/ALM
10	INP/TGON
11	BKIR
12	WARN
13	OGND
14	GND
15	+A
16	-A
17	-B
18	+B
19	+Z
20	-Z
21	Z
22	+CW/+PULS/+FA
23	-CW/-PULS/-FA
24	+CCW/+SIGN/+FB
25	-CCW/-SIGN/-FB
26	FG
27	
28	
29	
30	
31	
32	
33	
34	

3

Specifications

# 3-5 Servo Relay Units and Cable Specifications

This section provides the specifications for the Servo Relay Units and Cables used for connecting to Position Control Units for OMRON Programmable Controllers (SYSMAC). Select the models that match the Position Control Unit to be used. For details, refer to *Selecting Connecting Cables* on page 4-10.



## Servo Relay Units Specifications

### ■ XW2B-20J6-1B

This Servo Relay Unit connects to the following OMRON Position Control Units.

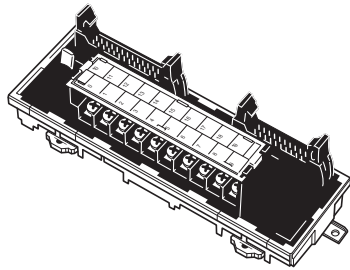

- ♦ CJ1W-NC113/-NC133
- ♦ CS1W-NC113/-NC133
- ♦ C200HW-NC113

### Dimensions

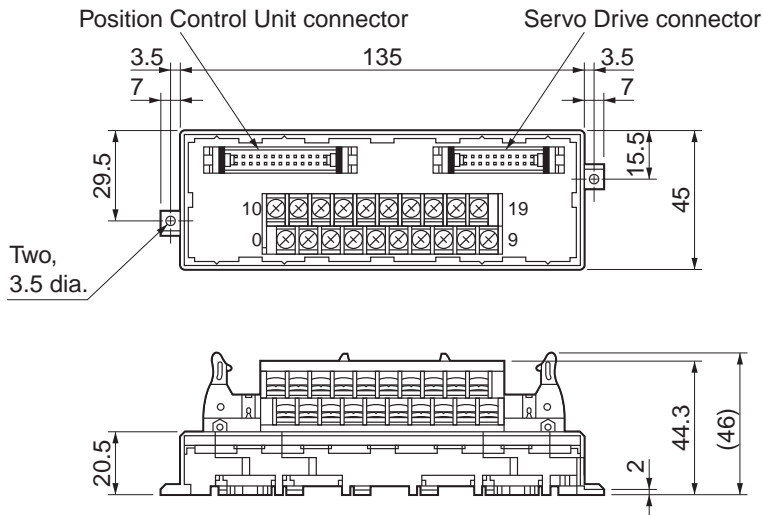

- ♦ Terminal Block pitch: 7.62 mm

## Wiring

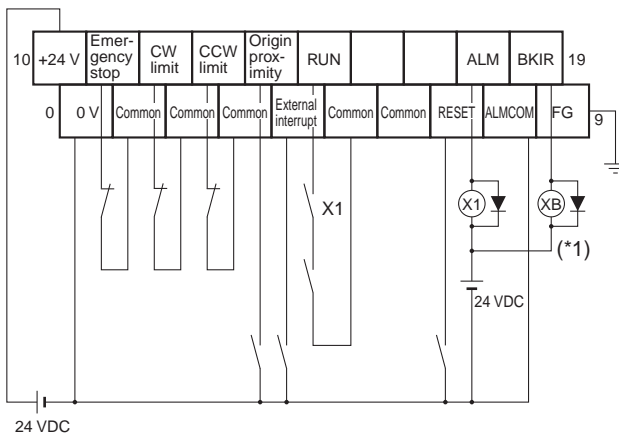

\*1. The XB contacts are used to turn ON/OFF the electromagnetic brake.

\*2. Do not connect unused terminals.

\*3. The 0 V terminal is internally connected to the common terminals.

\*4. Applicable crimp terminal: R1.25-3 (round with open end).

### ■ XW2B-40J6-2B

This Servo Relay Unit connects to the following OMRON Position Control Units.

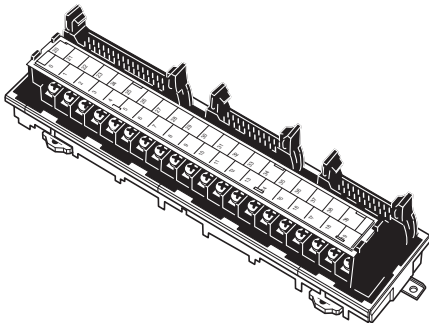

- ♦ CJ1W-NC213/-NC233/-NC413/-NC433
- ♦ CS1W-NC213/-NC233/-NC413/-NC433
- ♦ C200HW-NC213/-NC413

## Dimensions

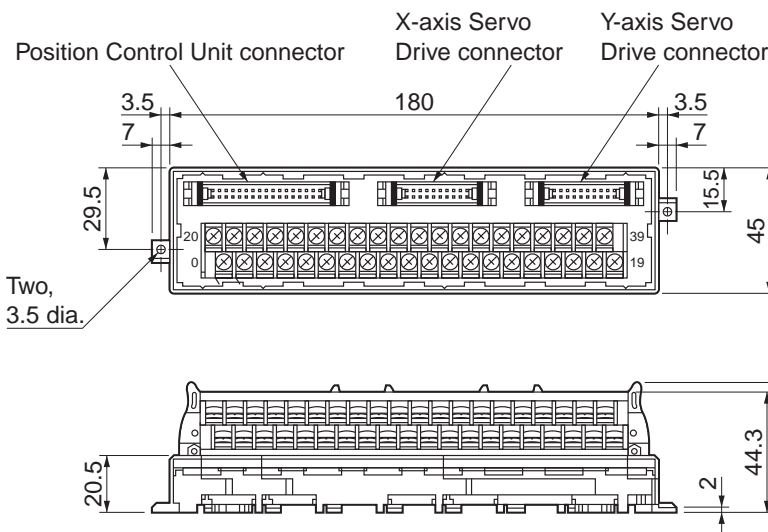

♦ Terminal Block pitch: 7.62 mm

Wiring

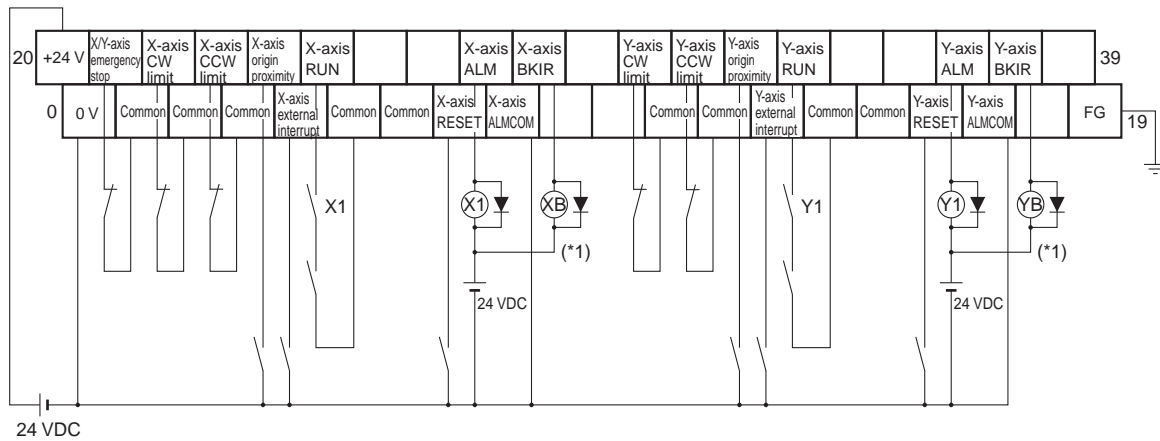

- \*1. The XB and YB contacts are used to turn ON/OFF the electromagnetic brake.
- \*2. Do not connect unused terminals.
- \*3. The 0 V terminal is internally connected to the common terminals.
- \*4. Applicable crimp terminal: R1.25-3 (round with open end).

■ XW2B-20J6-3B

This Servo Relay Unit connects to the following OMRON Programmable Controllers.

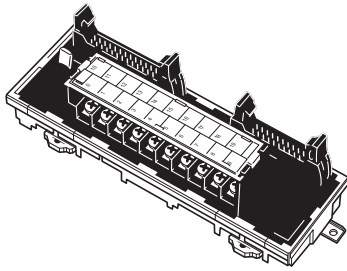

- ♦ CQM1H-PLB21  
(Pulse I/O Board for CQM1H-CPU51/CPU61)
- ♦ CQM1-CPU43-V1

Dimensions

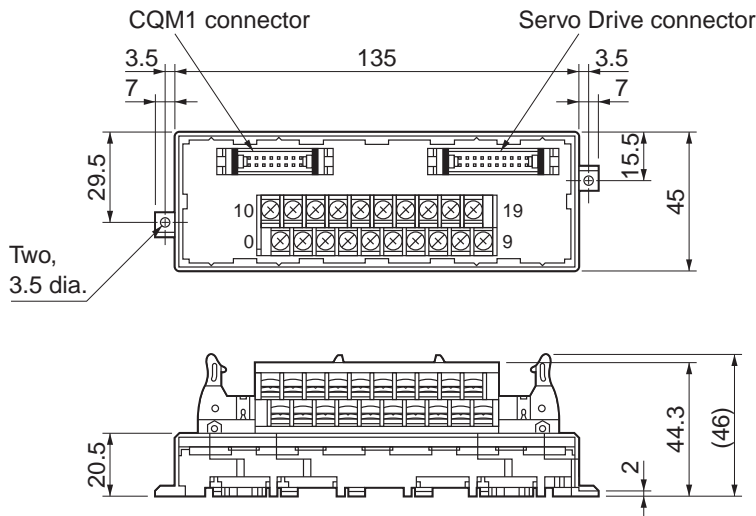

- ♦ Terminal Block pitch: 7.62 mm

### 3-5 Servo Relay Units and Cable Specifications

#### Wiring

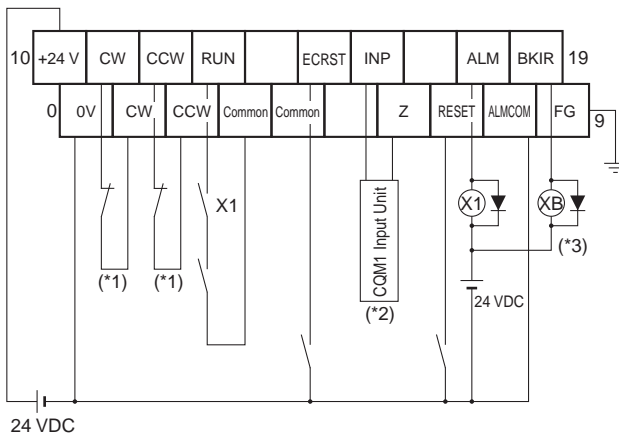

- \*1. If this signal is input, the output pulse from the CQM1 will be input to the high-speed counter.
- \*2. Input this output signal to a CQM1 Input Unit.
- \*3. The XB contacts are used to turn ON/OFF the electromagnetic brake.
- \*4. The phase Z is an open collector.
- \*5. Do not connect unused terminals.
- \*6. The 0 V terminal is internally connected to the common terminals.
- \*7. Applicable crimp terminal: R1.25-3 (round with open end).

#### ■ XW2B-20J6-8A

This Servo Relay Unit connects to the following OMRON Programmable Controllers.

- ◆ CJ1M-CPU21/-CPU22/-CPU23 (for 1 axis)

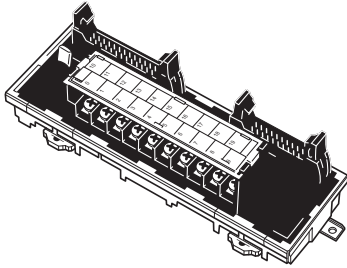



Dimensions

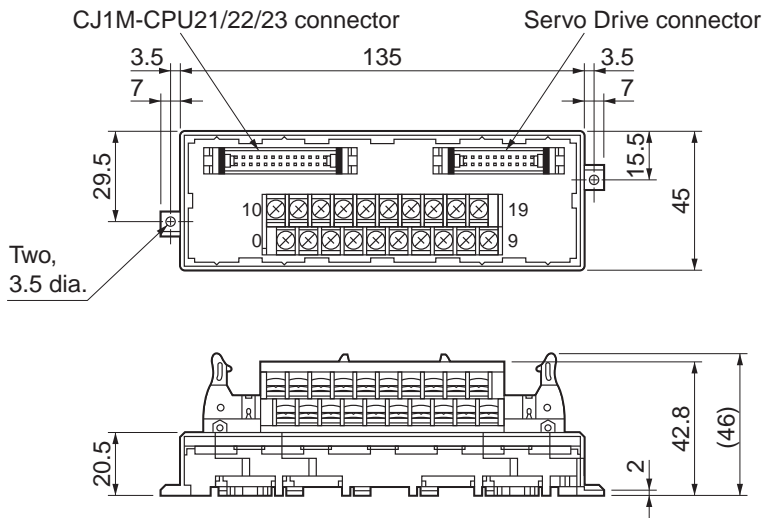

♦ Terminal Block pitch: 7.62 mm

Wiring

The Servo Drive phase-Z output signal is wired to the origin proximity signal in this Terminal Block.

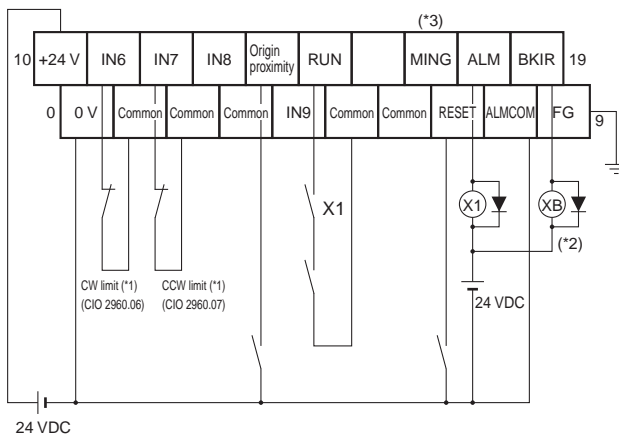

\*1. CW and CCW limit input signals can also be input through Input Units.  
 The bits for the CW/CCW limit inputs in the CJ1M are as follows: CW: A540.08, CCW: A540.09 for pulse output 0, and CW: A541.08, CCW: A541.09 for pulse output 1.  
 For example, the flag for the CW limit input (A540.08) can be controlled with an output from the ladder diagram using a bit allocated to the actual input (CIO 2960.06) on the Input Unit, as shown below.

Example:



- \*2. The XB contacts are used to turn ON/OFF the electromagnetic brake.
- \*3. Connection to the MING input terminal is invalid.
- \*4. Do not connect unused terminals.
- \*5. The 0 V terminal is internally connected to the common terminals.
- \*6. Applicable crimp terminal: R1.25-3 (round with open end).

### 3-5 Servo Relay Units and Cable Specifications

#### ■ XW2B-40J6-9A

This Servo Relay Unit connects to the following OMRON Programmable Controllers.

- ◆ CJ1M-CPU21/-CPU22/-CPU23 (for 2 axes)

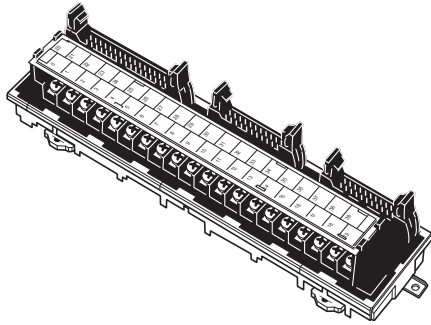

#### Dimensions

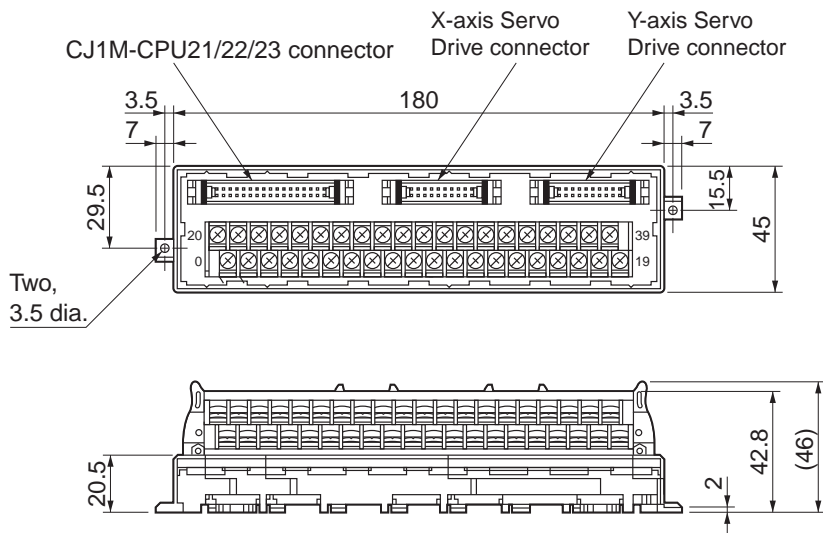

- ◆ Terminal Block pitch: 7.62 mm

#### Wiring

The Servo Drive phase-Z output signal is wired to the origin proximity signal in this Terminal Block.

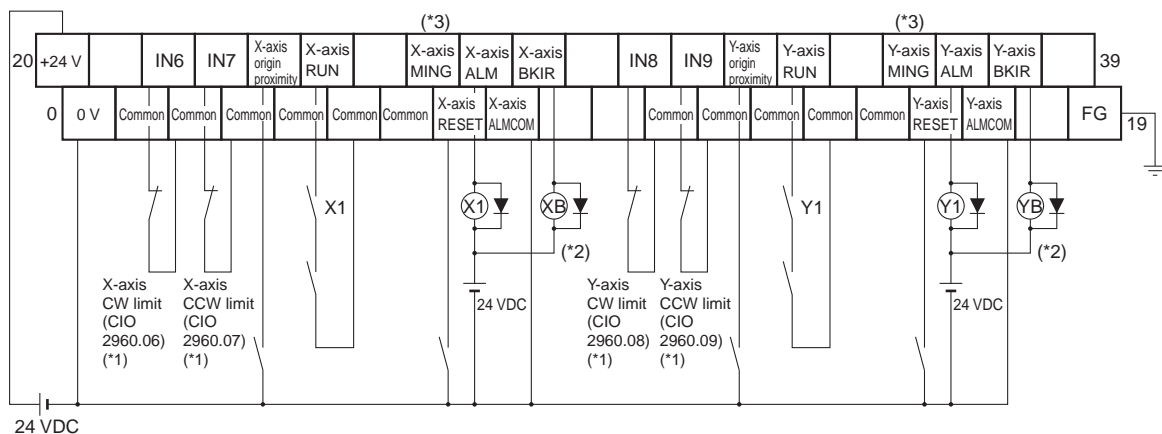

\*1. CW and CCW limit input signals can also be input through Input Units.

The bits for the CW/CCW limit inputs in the CJ1M are as follows: CW: A540.08, CCW: A540.09 for pulse output 0, and CW: A541.08, CCW: A541.09 for pulse output 1.

For example, the flag for the CW limit input (A540.08) can be controlled with an output from the ladder diagram using a bit allocated to the actual input (CIO 2960.06) on the Input Unit, as shown below.

Example:



- \*2. The XB and YB contacts are used to turn ON/OFF the electromagnetic brake.
- \*3. Connection to the MING input terminal is invalid.
- \*4. Do not connect unused terminals.
- \*5. The 0 V terminal is internally connected to the common terminals.
- \*6. Applicable crimp terminal: R1.25-3 (round with open end).

#### ■ XW2B-80J7-12A

This Servo Relay Unit connects to the following OMRON Programmable Controller.

◆ FQM1-MMP22

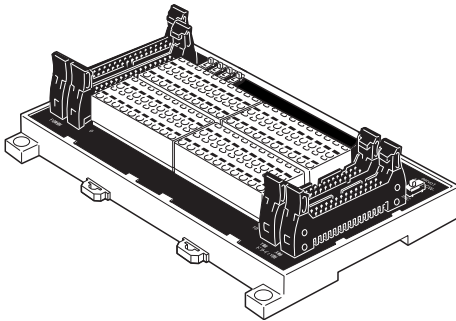

#### Dimensions

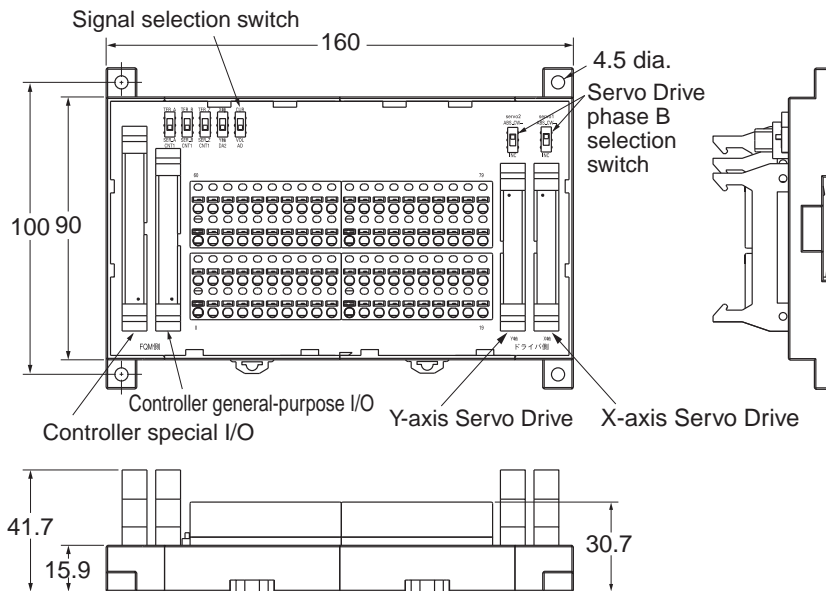

System Configuration Example

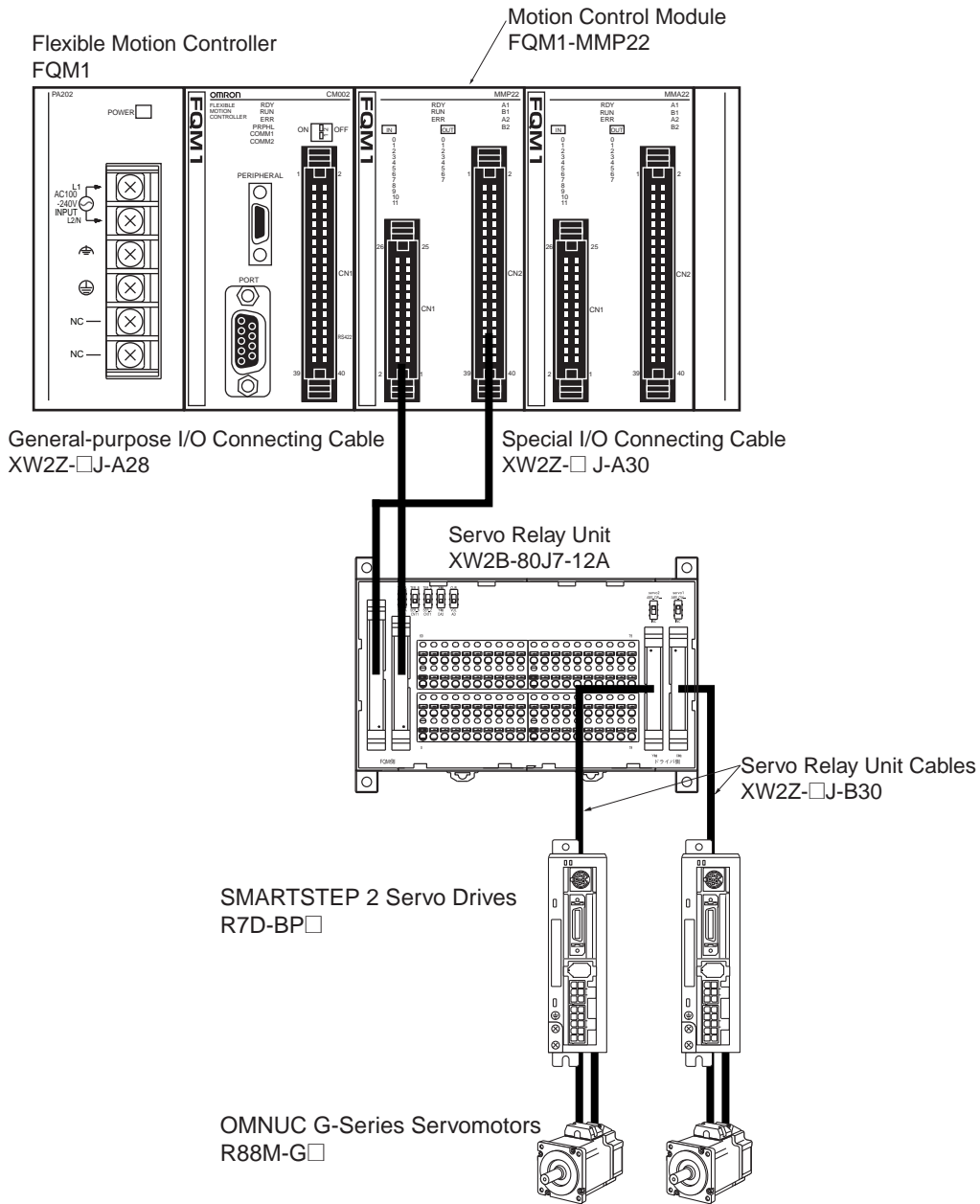

Terminal Block Connection

- ◆ The terminal block signal names are different depending on the Controller to be connected.
- ◆ A total of 80 terminals are provided (terminal numbers 0 to 79).
- ◆ Signal names and standard connections are listed in the following table.

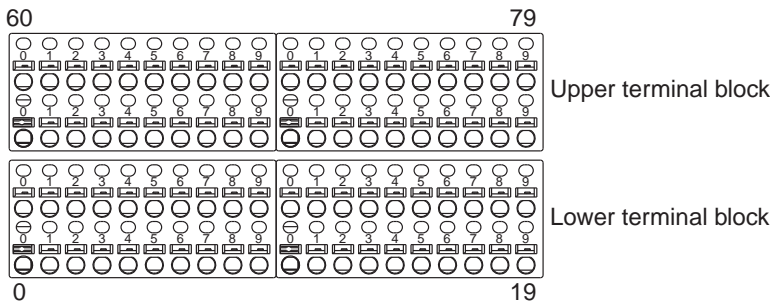

**FQM1-MMP22 Signal Names**

No.	60	61	62	63	64	65	66	67	68	69	70	71	72	73	74	75	76	77	78	79
Signal name	5 V (*1)	Latch signal 1 input	Latch signal 2 input	Servo #1 phase A LD+	Servo #1 phase B LD+	Servo #1 phase Z LD+	---	Servo #1 ALM	Servo #1 BKIR	IN4	IN5	IN6	IN7	---	Servo #1 RUN	Servo #1 RESET	Servo #1 ECRST	Servo #1 GSEL/TLSEL	---	---
No.	40	41	42	43	44	45	46	47	48	49	50	51	52	53	54	55	56	57	58	59
Signal name	0 V	Latch signal 1 common	Latch signal 2 common	Servo #1 phase A LD-	Servo #1 phase B LD-	Servo #1 phase Z LD-	---	Servo #1 INP	Common (0 V)	Common (0 V)	Common (0 V)	Common (0 V)	Common (0 V)	---	OUT0	OUT1	OUT2	OUT3	---	---

No.	20	21	22	23	24	25	26	27	28	29	30	31	32	33	34	35	36	37	38	39
Signal name	24 V (*2)	24 V (*3)	IN0	IN1	IN2	IN3	---	Servo #2 ALM	Servo #2 BKIR	IN8	IN9	IN10	IN11	---	Servo #2 RUN	Servo #2 RESET	Servo #2 ECRST	Servo #2 GSEL/TLSEL	---	FG
No.	0	1	2	3	4	5	6	7	8	9	10	11	12	13	14	15	16	17	18	19
Signal name	0 V	0 V	Common (0 V)	Common (0 V)	Common (0 V)	Common (0 V)	---	Servo #2 INP	Common (0 V)	Common (0 V)	Common (0 V)	Common (0 V)	Common (0 V)	---	OUT4	OUT5	OUT6	OUT7	---	FG

\*1: Use as a power supply for FQM1-MMP22 pulse outputs, or for the SEN output for an Absolute Encoder Servo Drive.

\*2: Use as a power supply for IN4 to IN11, OUT0 to OUT7, or Servo Drive control signals.

\*3: Use as a power supply for IN0 to IN3 (interrupt inputs) or latch inputs.

### 3-5 Servo Relay Units and Cable Specifications

#### Wiring Example

Servo Drive signals			FQM1 signals			
	#1	#2	For Servo Drive #1		For Servo Drive #2	
RUN	74	34	54	OUT0	14	OUT4
ECRST	76	36	56	OUT2	16	OUT6
INP	47	7	69	IN4	29	IN8
/ALM	67	27	70	IN5	30	IN9
BKIR	68	28	71	IN6	31	IN10

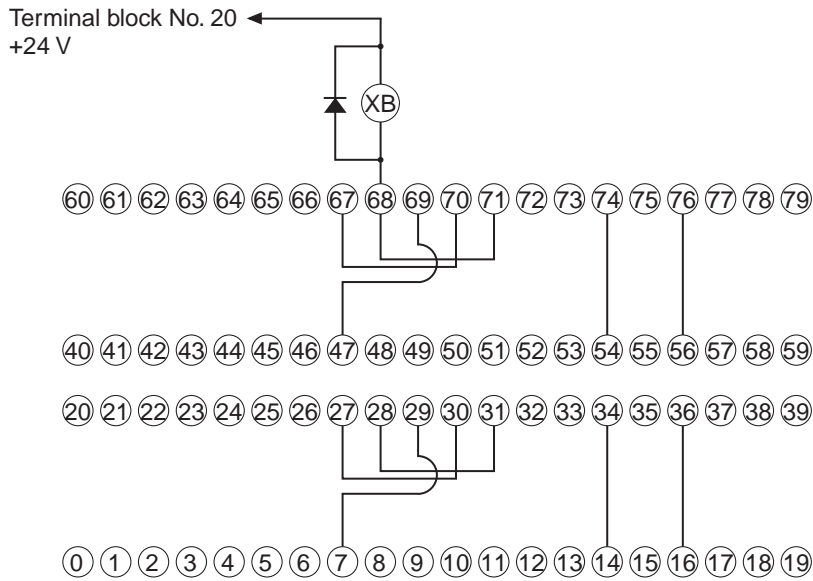

## Servo Drive-Servo Relay Unit Cable Specifications

### ■ Servo Drive Cable (XW2Z-□J-B29)

This Cable connects the Servo Drive to a Servo Relay Unit (XW2B-20J6-1B/-3B, XW2B-40J6-2B).

#### Cable Models

Model	Length (L)	Outer diameter of sheath	Weight
XW2Z-100J-B29	1 m	8.1 dia.	Approx. 0.1 kg
XW2Z-200J-B29	2 m		Approx. 0.2 kg

#### Connection Configuration and External Dimensions

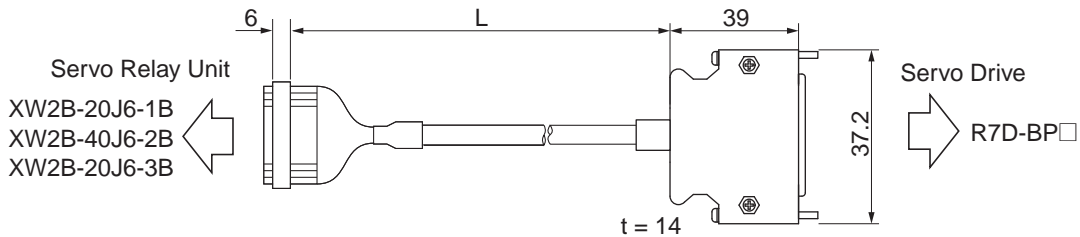

#### Wiring

Servo Relay Unit			Connector	Servo Drive	
Symbol	Wire/mark color	No.	No.	No.	Symbol
+24VIN	Blue/Red (1)	1	1	1	+24VIN
0GND	Blue/Black (1)	2	2	13	OGND
+CCW/+SIGN/+FB	Pink/Red (1)	3	3	24	+CCW/+SIGN/+FB
-CCW/-SIGN/-FB	Pink/Black (1)	4	4	25	-CCW/-SIGN/-FB
+CW/+PULS/+FA	Green/Red (1)	5	5	22	+CW/+PULS/+FA
-CW/-PULS/-FA	Green/Black (1)	6	6	23	-CW/-PULS/-FA
		7	7		
		8	8		
ECRST/VSEL2	Orange/Black (1)	9	9	4	ECRST/VSEL2
+Z	Gray/Red (1)	10	10	19	+Z
-Z	Gray/Black (1)	11	11	20	-Z
INP/TGON	Blue/Red (2)	12	12	10	INP/TGON
RUN	Blue/Black (2)	13	13	2	RUN
		14	14		
GSEL/VZERO/TLSEL	Pink/Red (2)	15	15	5	GSEL/VZERO/TLSEL
RESET	Pink/Black (2)	16	16	3	RESET
BKIR	Green/Red (2)	17	17	11	BKIR
/ALM	Green/Black (2)	18	18	9	/ALM
		19	19		
Shield	Shield	20	20	26	FG

Servo Relay Unit Connector

Connector socket: XG4M-2030

Strain relief: XG4T-2004

Cable

AWG28 × 4P + AWG28 × 9C UL2464

Servo Drive Connector

Connector plug: 10126-3000PE (Sumitomo 3M)

Connector case: 10326-52A0-008 (Sumitomo 3M)

### 3-5 Servo Relay Units and Cable Specifications

#### ■ Servo Drive Cable (XW2Z-□J-B30)

This Cable connects the Servo Drive to a Servo Relay Unit (XW2B-80J7-12A). Use this Cable for the FQM1-MMP22.

#### Cable Models

Model	Length (L)	Outer diameter of sheath	Weight
XW2Z-100J-B30	1 m	9.1 dia.	Approx. 0.1 kg
XW2Z-200J-B30	2 m		Approx. 0.2 kg

#### Connection Configuration and External Dimensions

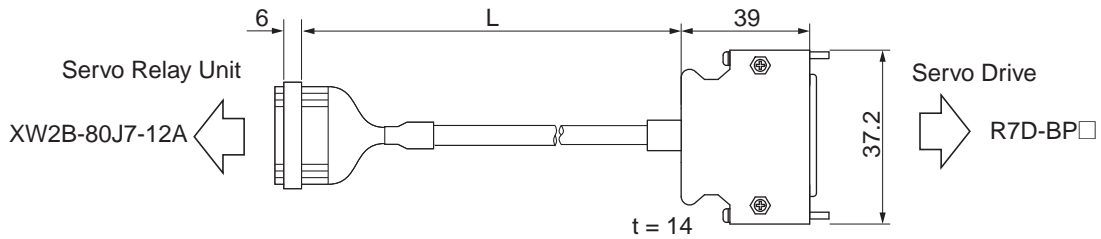

#### Wiring

Servo Relay Unit			Connector	Servo Drive		
Symbol	Wire/mark color	No.	No.	No.	Symbol	
+24VIN	Blue/Red (1)	1	1	1	+24VIN	
OGND	Blue/Black (1)	2	2	13	OGND	
+CCW/+SIGN/+FB	Pink/Red (1)	3	3	24	+CCW/+SIGN/+FB	
-CCW/-SIGN/-FB	Pink/Black (1)	4	4	25	-CCW/-SIGN/-FB	
+CW/+PULS/+FA	Green/Red (1)	5	5	22	+CW/+PULS/+FA	
-CW/-PULS/-FA	Green/Black (1)	6	6	23	-CW/-PULS/-FA	
	Orange/Red (1)	7	7			
ECRST/VSEL2	Orange/Black (1)	8	8	4	ECRST/VSEL2	
+Z	Gray/Red (1)	9	9	19	+Z	
-Z	Gray/Black (1)	10	10	20	-Z	
INP/TGON	Blue/Red (2)	11	11	10	INP/TGON	
RUN	Blue/Black (2)	12	12	2	RUN	
RESET	Pink/Red (2)	15	15	3	RESET	
BKIR	Pink/Black (2)	16	16	11	BKIR	
/ALM	Green/Red (2)	17	17	9	/ALM	
+A	Orange/Red (2)	21	21	15	+A	
-A	Orange/Black (2)	22	22	16	-A	
+B	Gray/Red (2)	23	23	18	+B	
-B	Gray/Black (2)	24	24	17	-B	
GSEL/VZERO/TLSEL	Blue/Red (3)	25	25	5	GSEL/VZERO/TLSEL	
Shield	Shield	30	30	26	FG	

#### Servo Relay Unit Connector

Connector socket: XG4M-3030

Strain relief: XG4T-3004

#### Cable

AWG28 × 7P + AWG28 × 6C UL2464

#### Servo Drive Connector

Connector plug: 10126-3000PE (Sumitomo 3M)

Connector case: 10326-52A0-008 (Sumitomo 3M)



#### ■ Servo Drive Cable (XW2Z-□J-B32)

This Cable connects the Servo Drive to a Servo Relay Unit (XW2B-20J6-8A, XW2B-40J6-9A).

#### Cable Models

Model	Length (L)	Outer diameter of sheath	Weight
XW2Z-100J-B32	1 m	8.1 dia.	Approx. 0.1 kg
XW2Z-200J-B32	2 m		Approx. 0.2 kg

#### Connection Configuration and External Dimensions

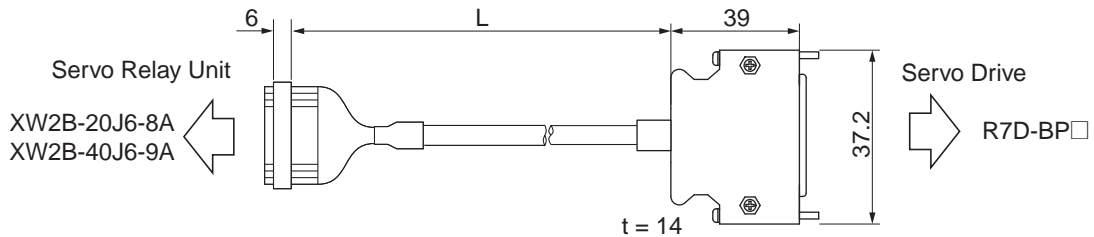

#### Wiring

Servo Relay Unit			Connector	Servo Drive	
Symbol	Wire/mark color	No.	No.	No.	Symbol
+24VIN	Blue/Red (1)	1	1	1	+24VIN
0GND	Blue/Black (1)	2	2	13	0GND
+CCW/+SIGN/+FB	Pink/Red (1)	3	3	24	+CCW/+SIGN/+FB
-CCW/-SIGN/-FB	Pink/Black (1)	4	4	25	-CCW/-SIGN/-FB
+CW/+PULS/+FA	Green/Red (1)	5	5	22	+CW/+PULS/+FA
-CW/-PULS/-FA	Green/Black (1)	6	6	23	-CW/-PULS/-FA
		7	7		
		8	8		
		9	9		
+Z	Gray/Red (1)	10	10	19	+Z
-Z	Gray/Black (1)	11	11	20	-Z
INP/TGON	Blue/Red (2)	12	12	10	INP/TGON
RUN	Blue/Black (2)	13	13	2	RUN
ECRST/VSEL2	Orange/Black (1)	14	14		ECRST/VSEL2
GSEL/VZERO/TLSEL	Pink/Red (2)	15	15	5	GSEL/VZERO/TLSEL
RESET	Pink/Black (2)	16	16	3	RESET
BKIR	Green/Red (2)	17	17	11	BKIR
/ALM	Green/Black (2)	18	18	9	/ALM
		19	19		
Shield	Shield	20	20	26	FG

#### Servo Relay Unit Connector

Connector socket: XG4M-2030

Strain relief: XG4T-2004

#### Cable

AWG28 × 4P + AWG28 × 9C UL2464

#### Servo Drive Connector

Connector plug: 10126-3000PE (Sumitomo 3M)

Connector case: 10326-52A0-008 (Sumitomo 3M)

## Position Control Unit-Servo Relay Unit Cable Specifications

### ■ Position Control Unit Cable (XW2Z-□J-A3)

This Cable connects a Programmable Controller (CQM1H-PLB21, CQM1-CPU43-V1) to a Servo Relay Unit (XW2B-20J6-3B).

#### Cable Models

Model	Length (L)	Outer diameter of sheath	Weight
XW2Z-050J-A3	50 cm	7.5 dia.	Approx. 0.1 kg
XW2Z-100J-A3	1 m		Approx. 0.1 kg

#### Connection Configuration and External Dimensions

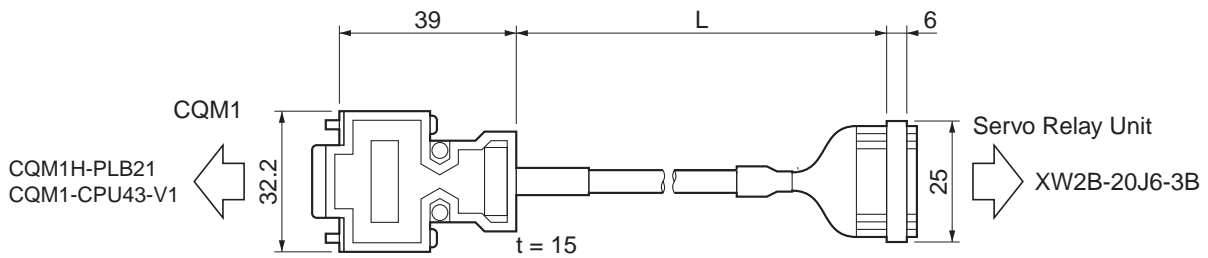

#### Wiring

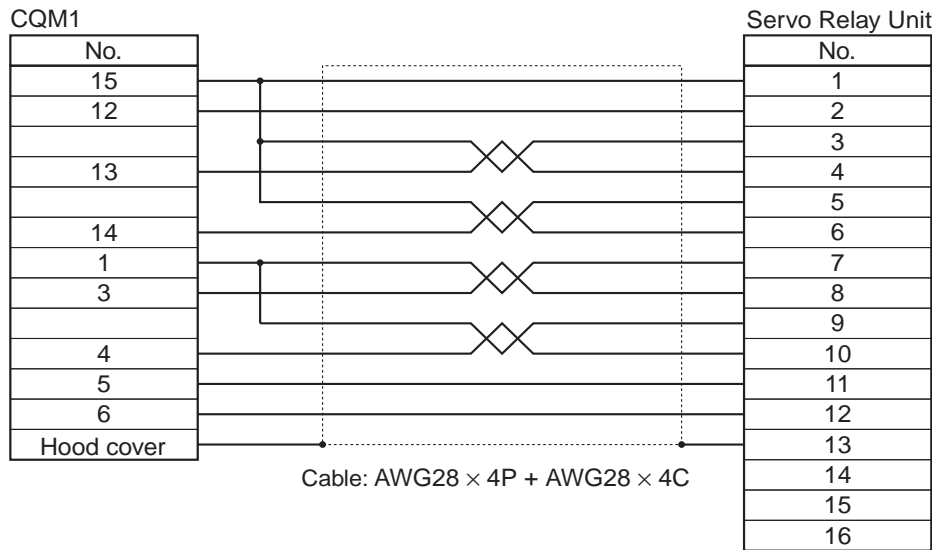

■ Position Control Unit Cable (XW2Z-□J-A6)

This Cable connects a Position Control Unit (CS1W-NC113, C200HW-NC113) to a Servo Relay Unit (XW2B-20J6-1B).

Cable Models

Model	Length (L)	Outer diameter of sheath	Weight
XW2Z-050J-A6	50 cm	8.0 dia.	Approx. 0.1 kg
XW2Z-100J-A6	1 m		Approx. 0.1 kg

Connection Configuration and External Dimensions

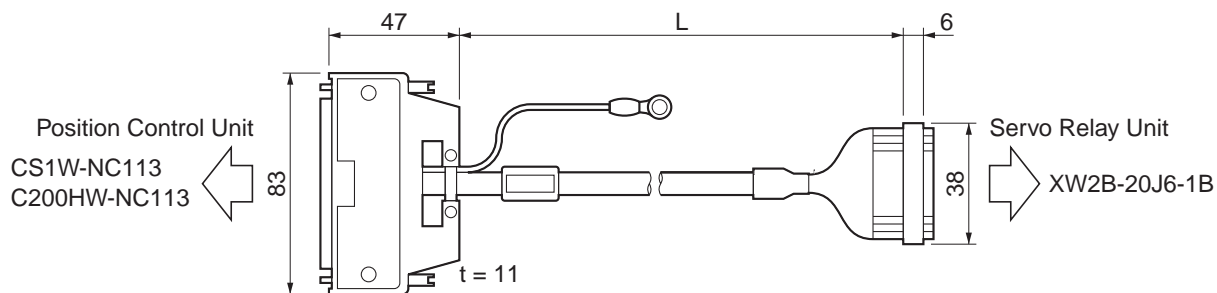

Wiring

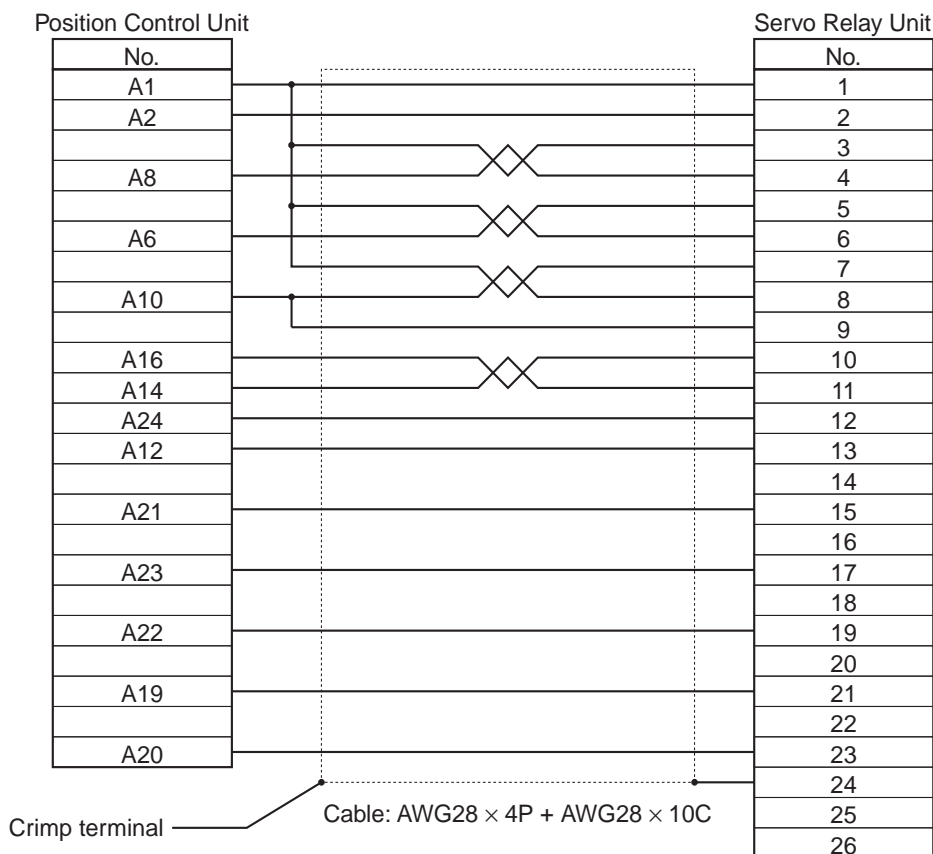

### 3-5 Servo Relay Units and Cable Specifications

#### ■ Position Control Unit Cable (XW2Z-□J-A7)

This Cable connects a Position Control Unit (CS1W-NC213/413, C200HW-NC213/413) to a Servo Relay Unit (XW2B-40J6-2B).

#### Cable Models

Model	Length (L)	Outer diameter of sheath	Weight
XW2Z-050J-A7	50 cm	10.0 dia.	Approx. 0.1 kg
XW2Z-100J-A7	1 m		Approx. 0.2 kg

#### Connection Configuration and External Dimensions

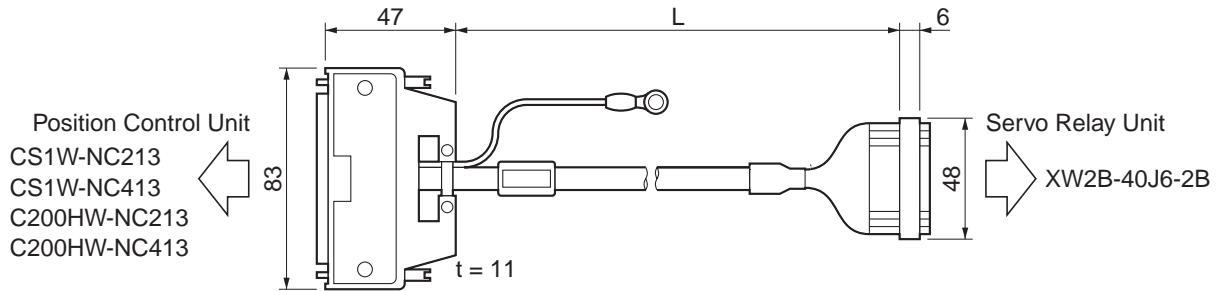

#### Wiring

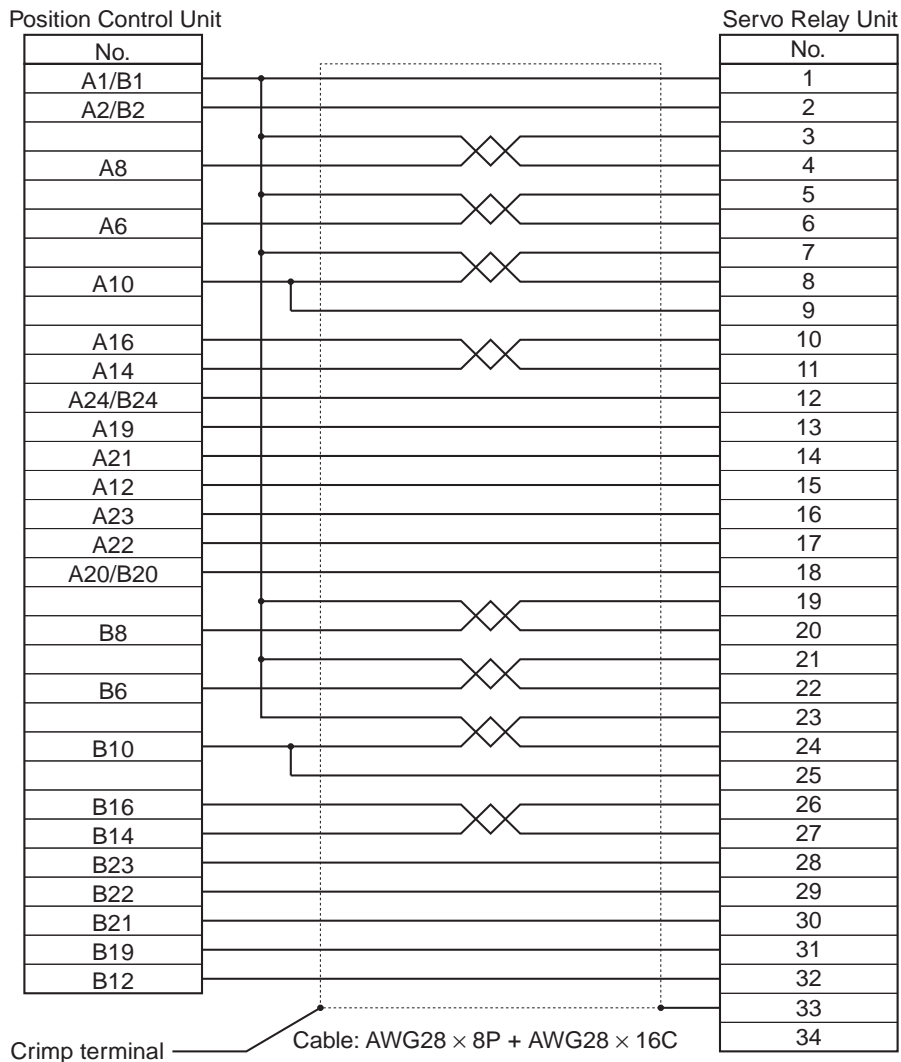

#### ■ Position Control Unit Cable (XW2Z-□J-A10)

This Cable connects a Position Control Unit (CS1W-NC133) to a Servo Relay Unit (XW2B-20J6-1B).

#### Cable Models

Model	Length (L)	Outer diameter of sheath	Weight
XW2Z-050J-A10	50 cm	10.0 dia.	Approx. 0.1 kg
XW2Z-100J-A10	1 m		Approx. 0.2 kg

#### Connection Configuration and External Dimensions

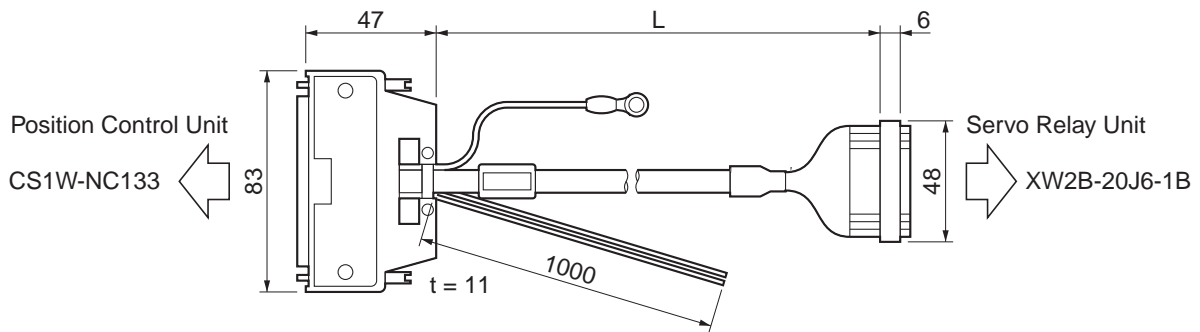

#### Wiring

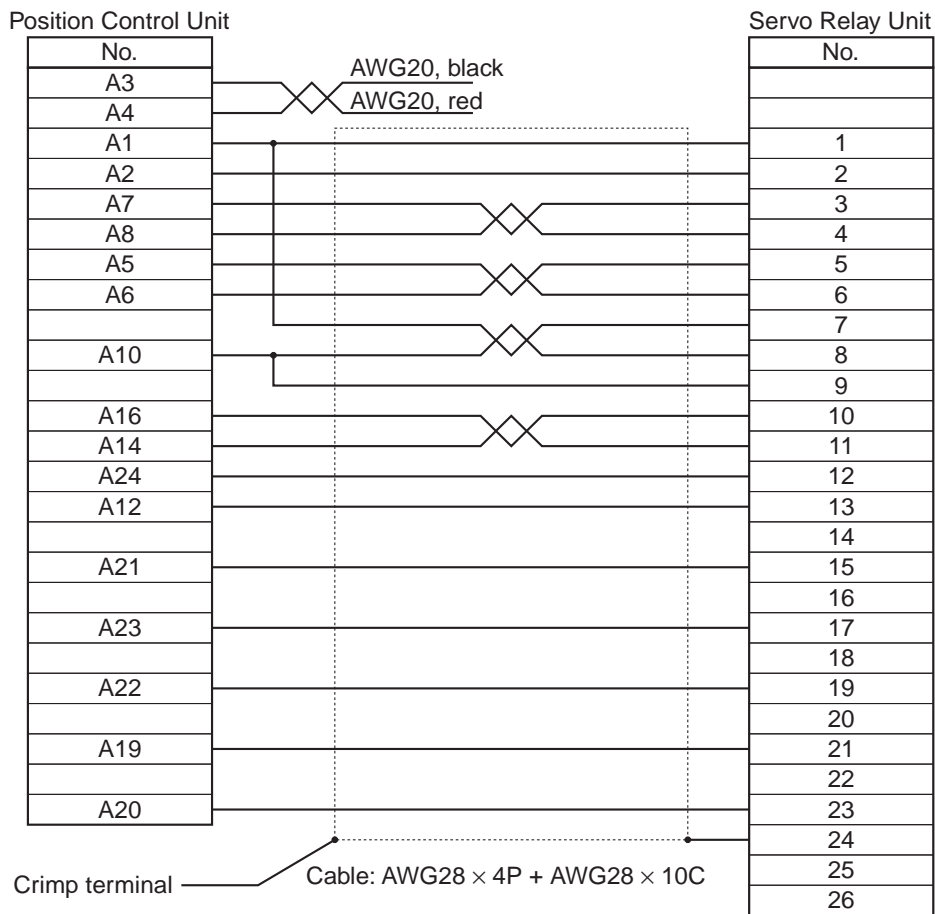

### 3-5 Servo Relay Units and Cable Specifications

#### ■ Position Control Unit Cable (XW2Z-□J-A11)

This Cable connects a Position Control Unit (CS1W-NC233/433) to a Servo Relay Unit (XW2B-40J6-2B).

#### Cable Models

Model	Length (L)	Outer diameter of sheath	Weight
XW2Z-050J-A11	50 cm	10.0 dia.	Approx. 0.1 kg
XW2Z-100J-A11	1 m		Approx. 0.2 kg

#### Connection Configuration and External Dimensions

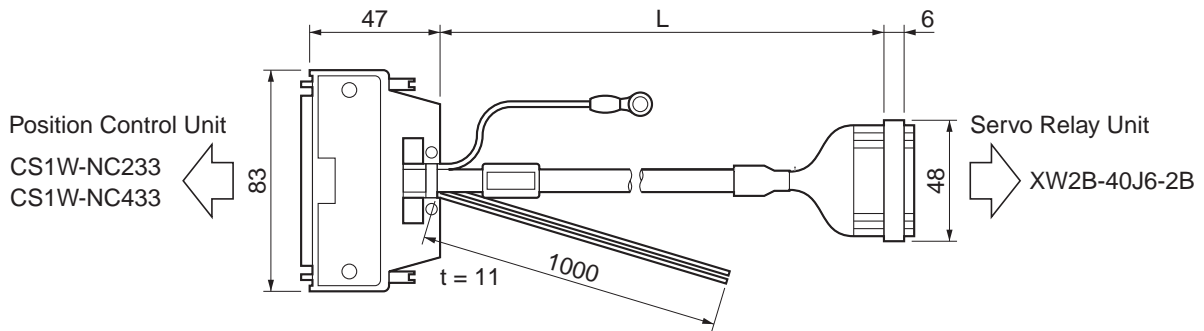

#### Wiring

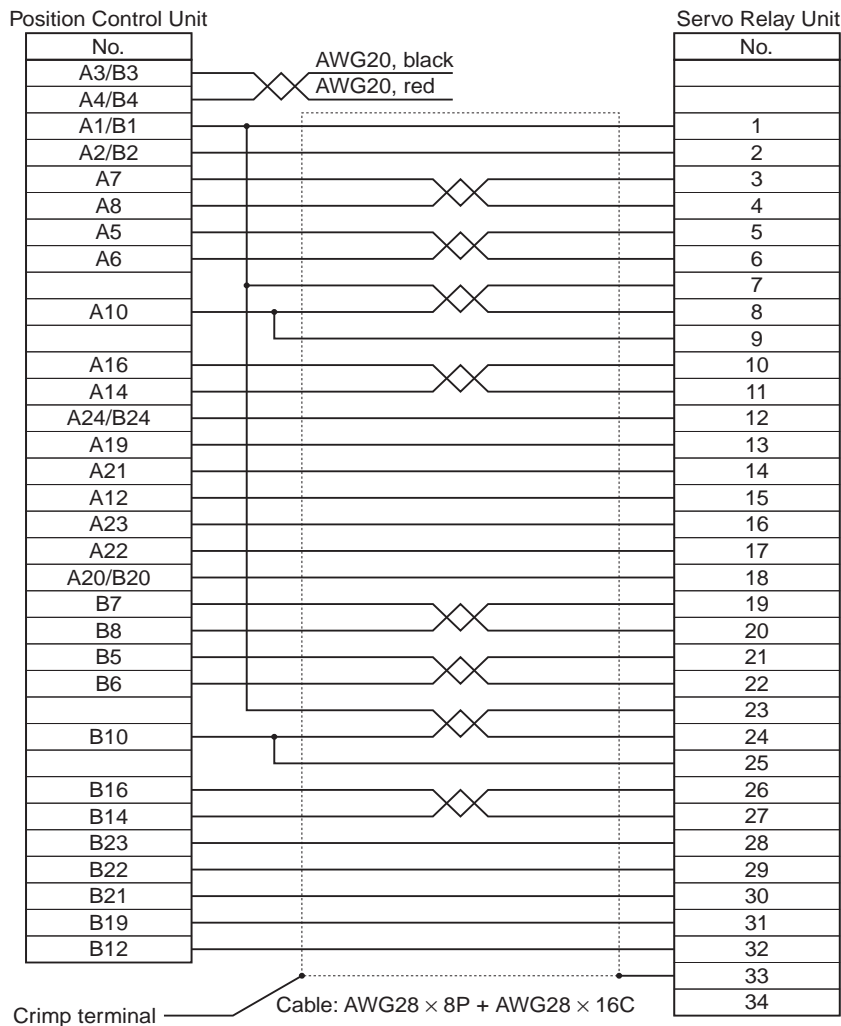

■ Position Control Unit Cable (XW2Z-□J-A14)

This Cable connects a Position Control Unit (CJ1W-NC113) to a Servo Relay Unit (XW2B-20J6-1B).

Cable Models

Model	Length (L)	Outer diameter of sheath	Weight
XW2Z-050J-A14	50 cm	10.0 dia.	Approx. 0.1 kg
XW2Z-100J-A14	1 m		Approx. 0.2 kg

Connection Configuration and External Dimensions

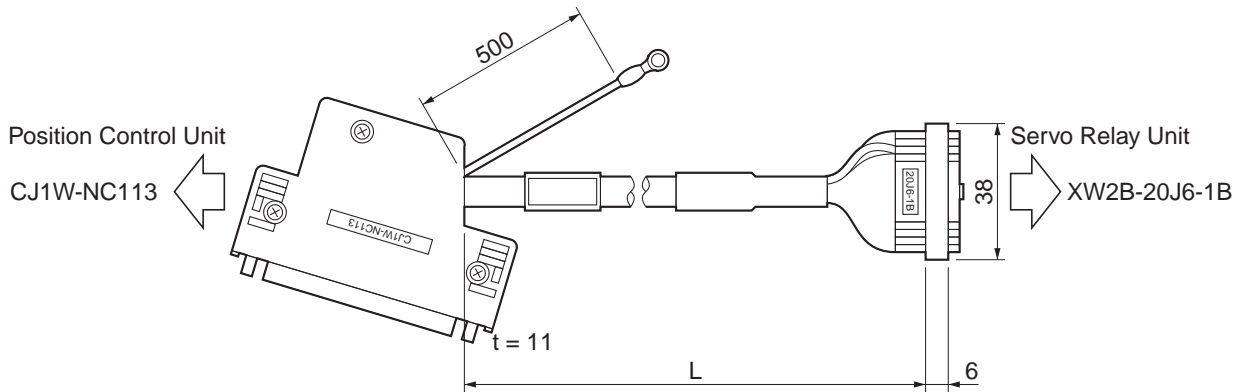

Wiring

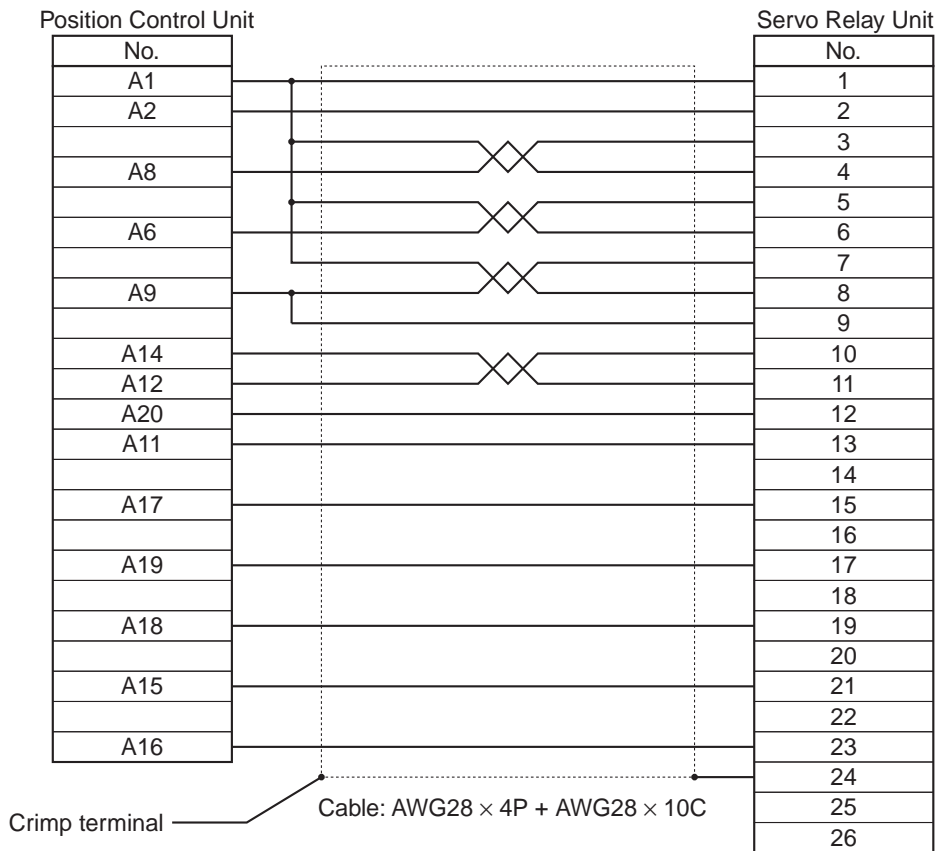

### 3-5 Servo Relay Units and Cable Specifications

#### ■ Position Control Unit Cable (XW2Z-□J-A15)

This Cable connects a Position Control Unit (CJ1W-NC213/413) to a Servo Relay Unit (XW2B-40J6-2B).

#### Cable Models

Model	Length (L)	Outer diameter of sheath	Weight
XW2Z-050J-A15	50 cm	10.0 dia.	Approx. 0.1 kg
XW2Z-100J-A15	1 m		Approx. 0.2 kg

#### Connection Configuration and External Dimensions

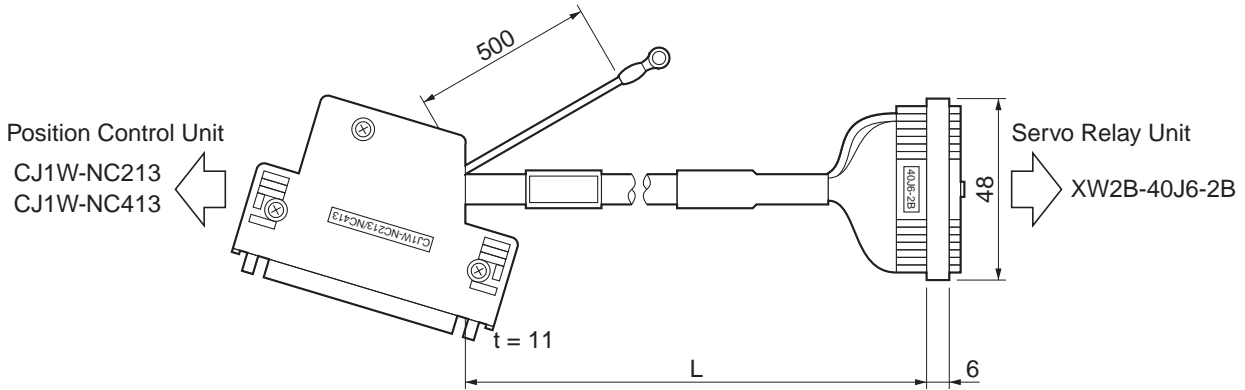

#### Wiring

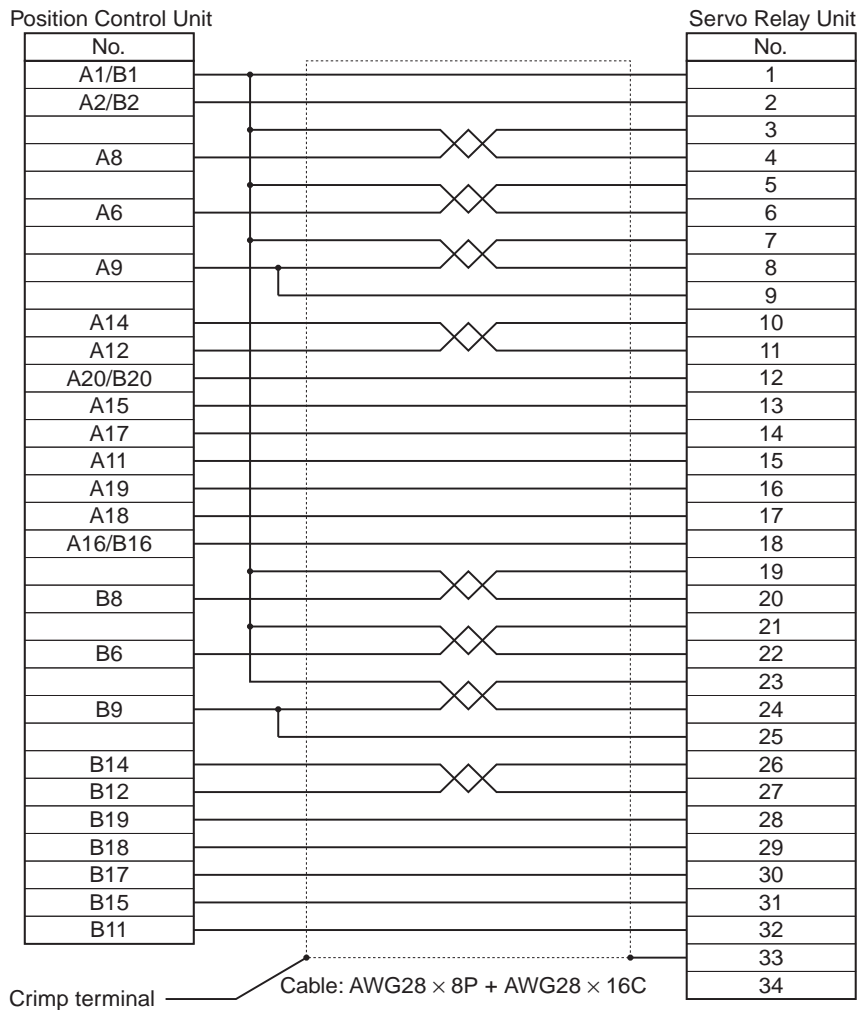



■ Position Control Unit Cable (XW2Z-□J-A18)

This Cable connects a Position Control Unit (CJ1W-NC133) to a Servo Relay Unit (XW2B-20J6-1B).

Cable Models

Model	Length (L)	Outer diameter of sheath	Weight
XW2Z-050J-A18	50 cm	10.0 dia.	Approx. 0.1 kg
XW2Z-100J-A18	1 m		Approx. 0.2 kg

Connection Configuration and External Dimensions

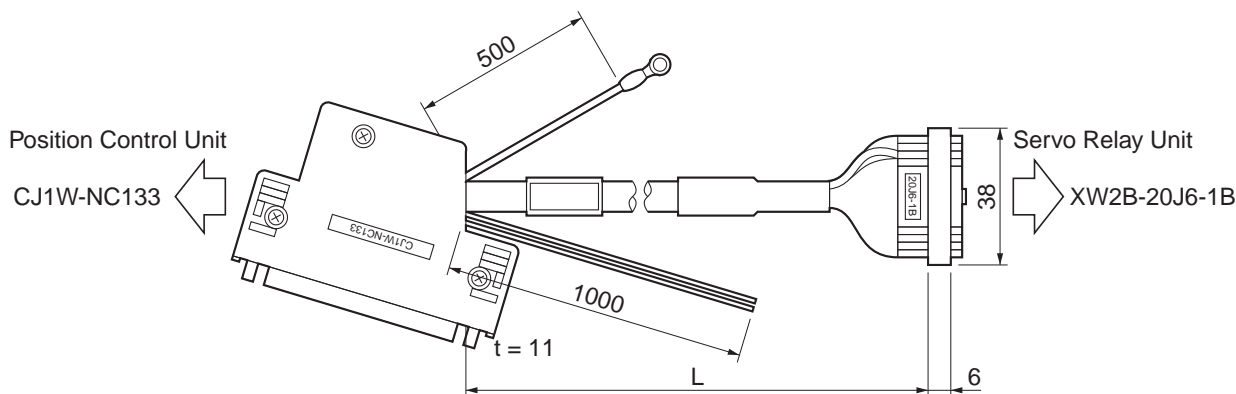

Wiring

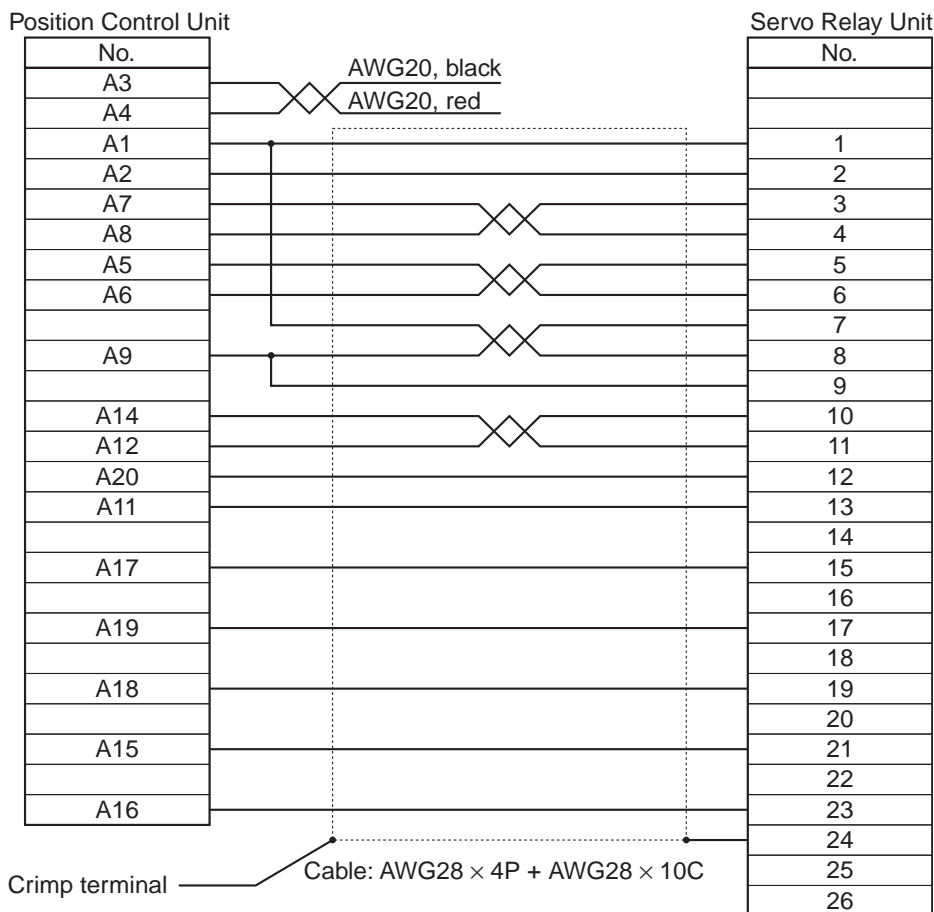

### 3-5 Servo Relay Units and Cable Specifications

#### ■ Position Control Unit Cable (XW2Z-□J-A19)

This Cable connects a Position Control Unit (CJ1W-NC233/433) to a Servo Relay Unit (XW2B-40J6-2B).

#### Cable Models

Model	Length (L)	Outer diameter of sheath	Weight
XW2Z-050J-A19	50 cm	10.0 dia.	Approx. 0.1 kg
XW2Z-100J-A19	1 m		Approx. 0.2 kg

#### Connection Configuration and External Dimensions

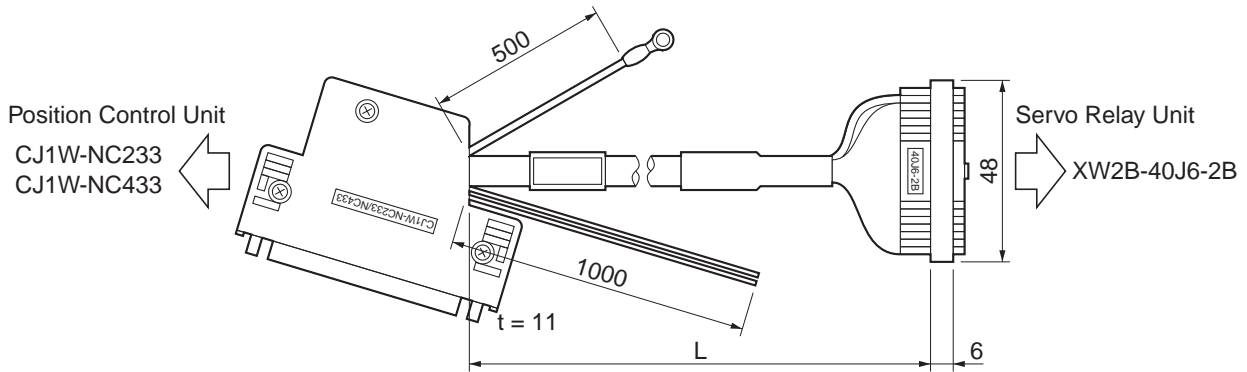

#### Wiring

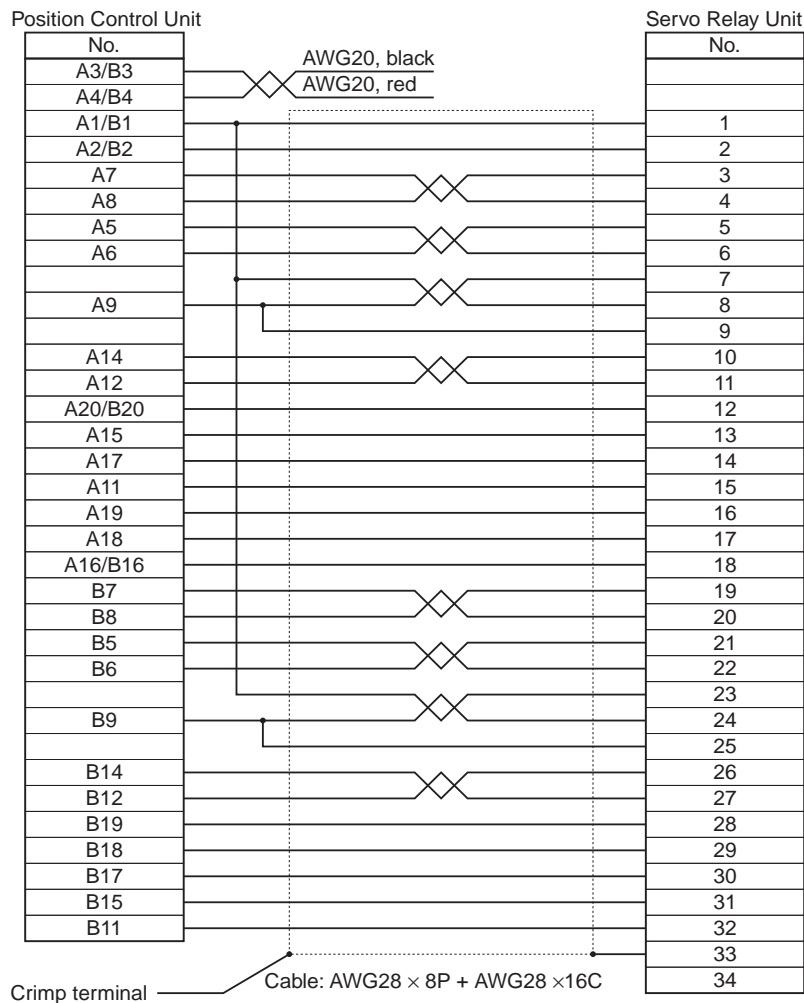

#### ■ Position Control Unit Cable (XW2Z-□J-A33)

This Cable connects a Programmable Controller (CJ1M-CPU21/CPU22/CPU23) to a Servo Relay Unit (XW2B-20J6-8A, XW2B-40J6-9A).

#### Cable Models

Model	Length (L)	Outer diameter of sheath	Weight
XW2Z-050J-A33	50 cm	10.0 dia.	Approx. 0.1 kg
XW2Z-100J-A33	1 m		Approx. 0.2 kg

#### Connection Configuration and External Dimensions

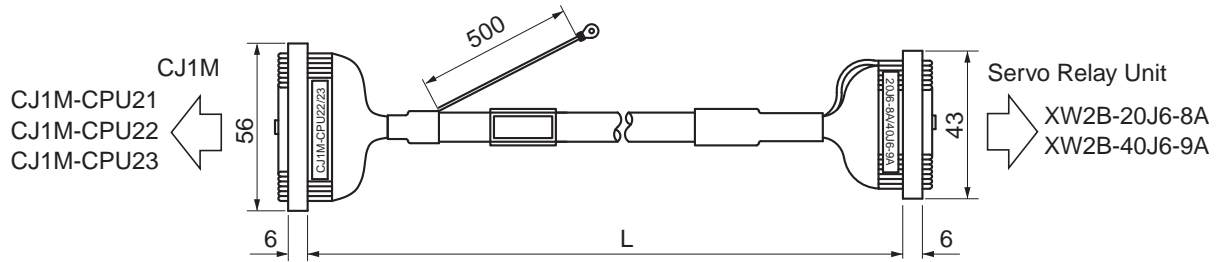

#### Wiring

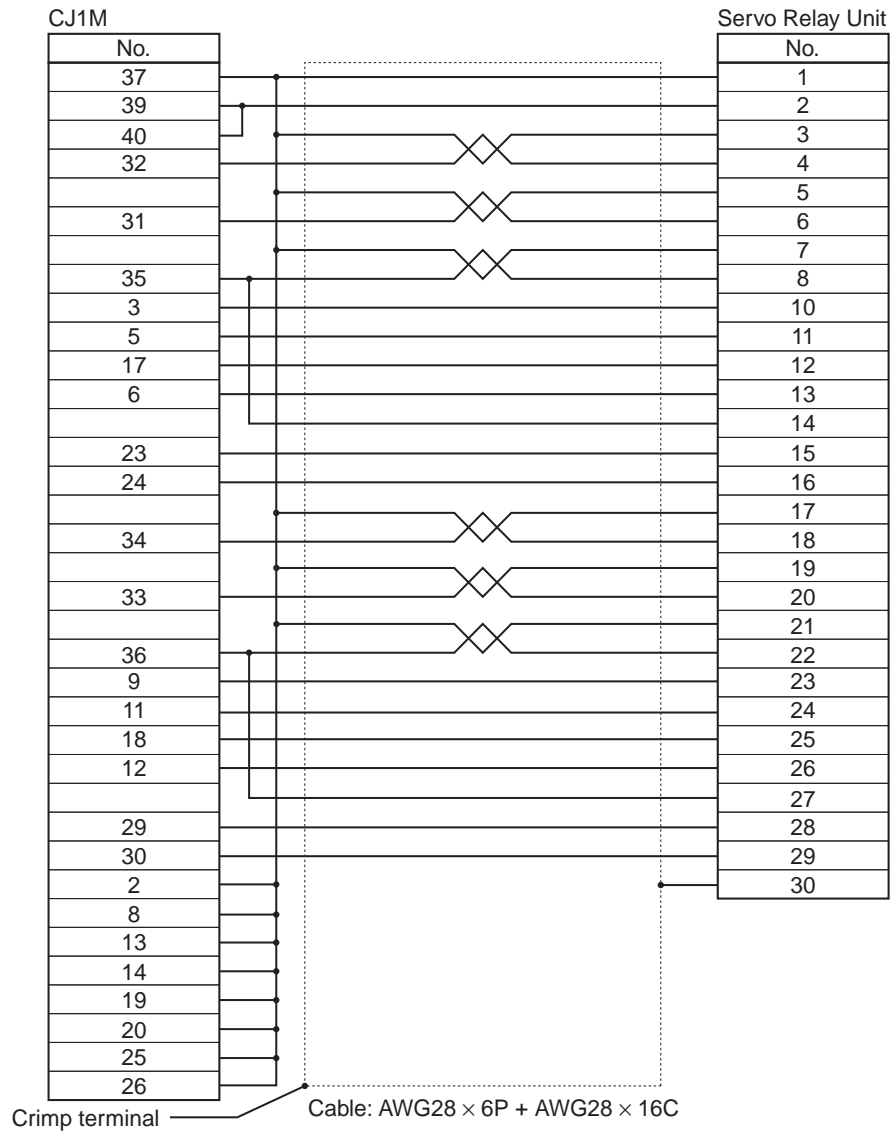

### 3-5 Servo Relay Units and Cable Specifications

#### ■ Position Control Unit Cable (XW2Z-□J-A28)

This Cable connects the general-purpose I/O connector of a Flexible Motion Controller (FQM1-MMP22) to a Servo Relay Unit (XW2B-80J7-12A).

#### Cable Models

Model	Length (L)	Outer diameter of sheath	Weight
XW2Z-050J-A28	50 cm	10.0 dia.	Approx. 0.1 kg
XW2Z-100J-A28	1 m		Approx. 0.2 kg
XW2Z-200J-A28	2 m		Approx. 0.3 kg

#### Connection Configuration and External Dimensions

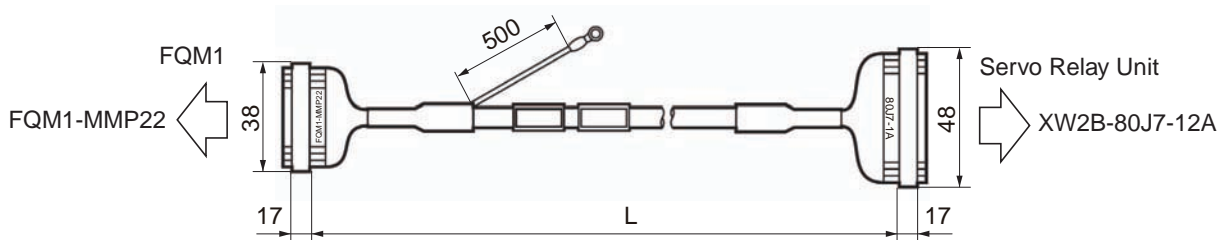

#### Wiring

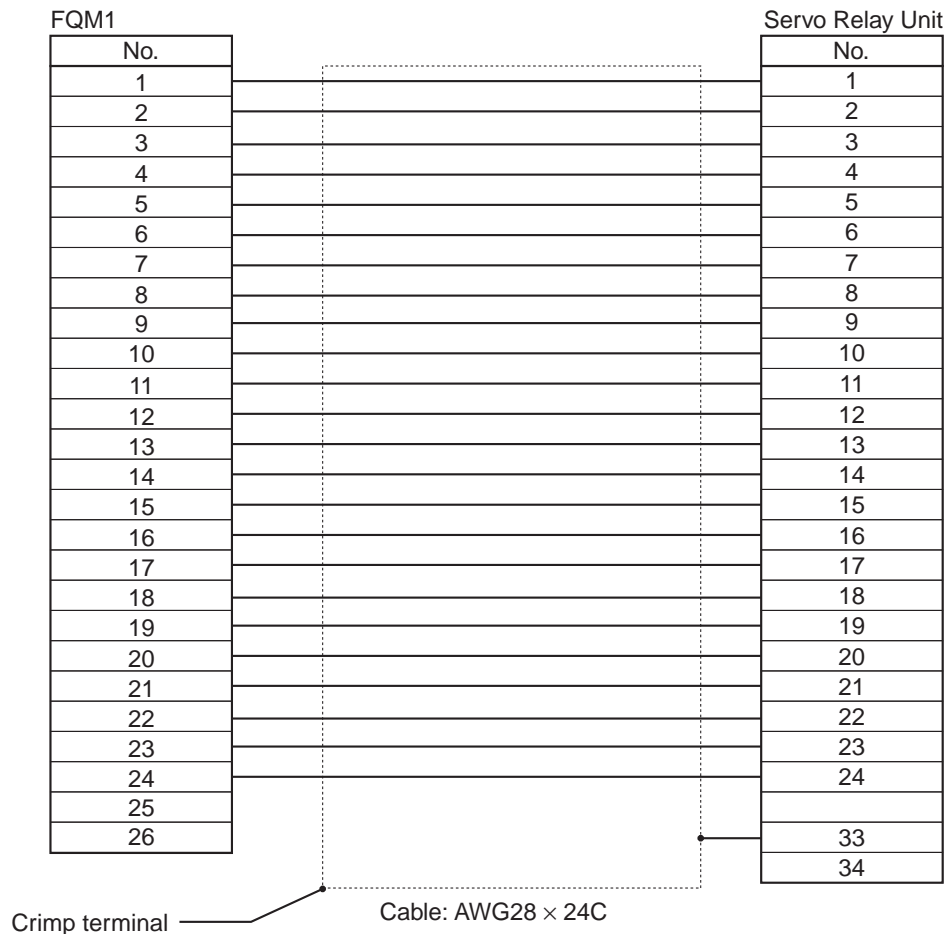

■ Position Control Unit Cable (XW2Z-□J-A30)

This Cable connects the special I/O connector of a Flexible Motion Controller (FQM1-MMP22) to a Servo Relay Unit (XW2B-80J7-12A).

Cable Models

Model	Length (L)	Outer diameter of sheath	Weight
XW2Z-050J-A30	50 cm	10.0 dia.	Approx. 0.1 kg
XW2Z-100J-A30	1 m		Approx. 0.2 kg
XW2Z-200J-A30	2 m		Approx. 0.3 kg

Connection Configuration and External Dimensions

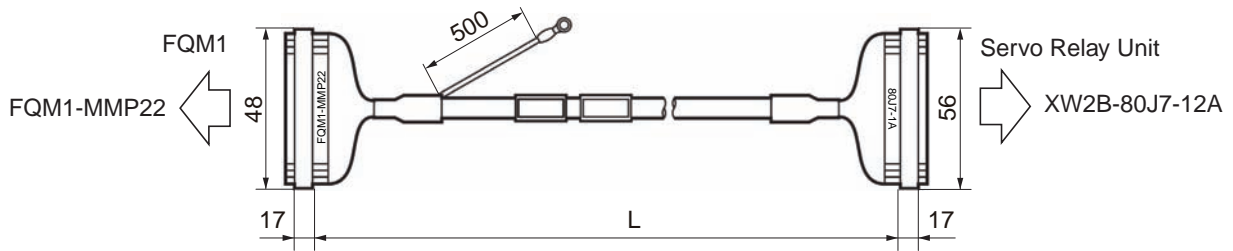

Wiring

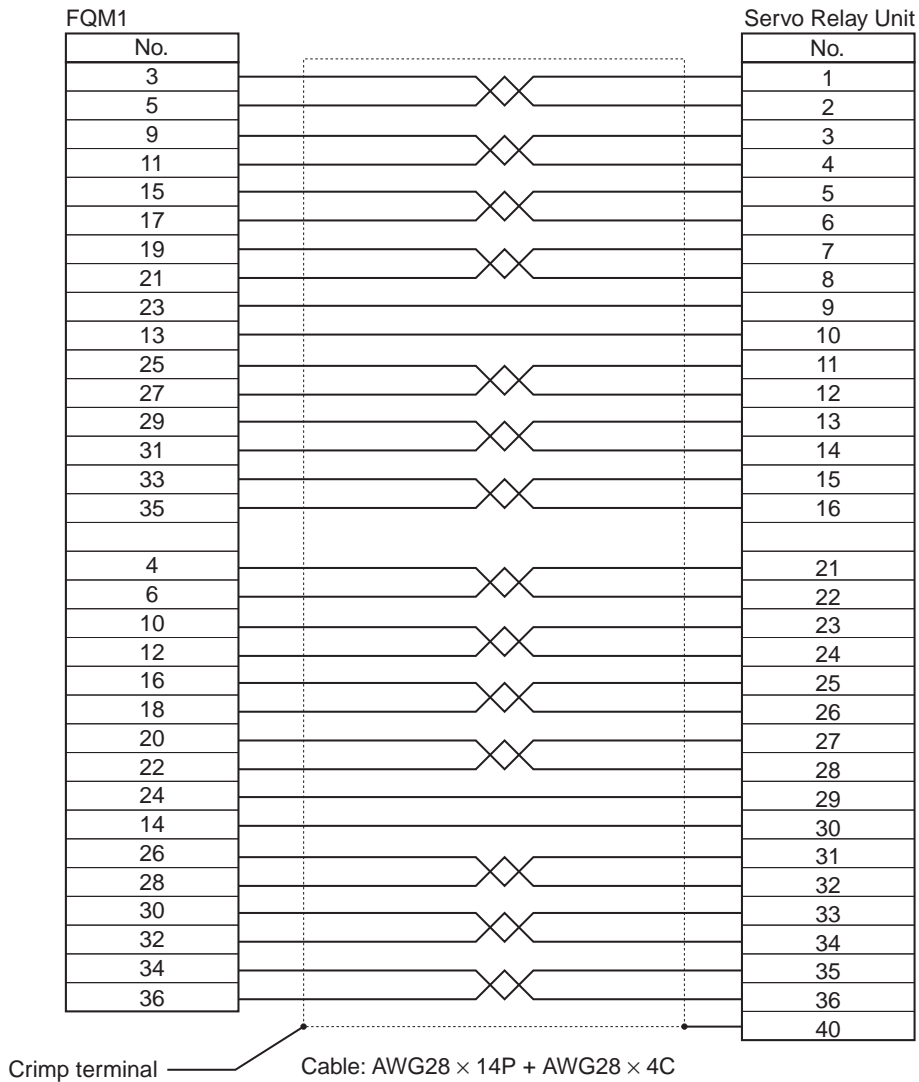

## 3-6 Parameter Unit Specifications

The Parameter Unit is required for parameter setting and monitoring for the Servo Drive.

### R88A-PR02G Hand-held Parameter Unit

#### ■ General Specifications

Item	Specifications
Operating ambient temperature	0 to 55°C
Operating ambient humidity	90% RH max. (with no condensation)
Storage ambient temperature	-20 to 80°C
Storage ambient humidity	90% RH max. (with no condensation)
Operating and storage atmosphere	No corrosive gases
Vibration resistance	5.9 m/s <sup>2</sup> max.

#### ■ Performance Specifications

Item	Specifications	
Type	Hand-held	
Cable length	1.5 m	
Connectors	Mini DIN 8P MD connector	
Display	7-segment LED	
External dimensions	62 (W) × 114 (H) × 15 (D) mm	
Weight	Approx. 0.1 kg (including cable)	
Communications specifications	Standard	RS-232
	Communications method	Asynchronous (ASYNC)
	Baud rate	9,600 bps
	Start bits	1 bit
	Data	8 bits
	Parity	None
	Stop bits	1 bit

## 3-7 External Regeneration Resistors Specifications

Refer to 4-4 *Regenerative Energy Absorption* to ensure correct use of External Regeneration Resistors.

### ■ R88A-RR08050S/-RR080100S/-RR22047S Specifications

Model	Resistance	Nominal capacity	Regeneration absorption for 120°C temperature rise	Heat radiation condition	Thermal switch output specifications
R88A-RR08050S	50 Ω	80 W	20 W	Aluminum 250 × 250, Thickness: 3.0	Operating temperature: 150°C±5%, NC contact, Rated output: 30 VDC, 50 mA max.
R88A-RR080100S	100 Ω	80 W	20 W	Aluminum 250 × 250, Thickness: 3.0	Operating temperature: 150°C±5%, NC contact, Rated output: 30 VDC, 50 mA max.
R88A-RR22047S	47 Ω	220 W	70 W	Aluminum 350 × 350, Thickness: 3.0	Operating temperature: 170°C±5%, NC contact, Rated output: 250 VAC, 0.2 A max.

## 3-8 Reactor Specifications

A Reactor is connected to the Servo Drive as a harmonic current control measure. Select a model matching the Servo Drive to be used.

### ■ Specifications

Reactor type	Specifications			
	Model	Rated current (A)	Inductance (mH)	Weight (kg)
Single-phase Reactors	3G3AX-DL2002	1.6 A	21.4 mH	0.8 kg
	3G3AX-DL2004	3.2 A	10.7 mH	1.0 kg
	3G3AX-DL2007	6.1 A	6.75 mH	1.3 kg
Three-phase Reactor	3G3AX-AL2025	10 A	2.8 mH	2.8 kg



# Chapter 4

## System Design

<b>4-1</b>	<b>Installation Conditions .....</b>	<b>4-1</b>
	Servo Drives .....	4-1
	Servomotors.....	4-3
	Decelerators.....	4-5
<b>4-2</b>	<b>Wiring .....</b>	<b>4-9</b>
	Connecting Cables.....	4-9
	Selecting Connecting Cables.....	4-10
	Peripheral Device Connection Examples.....	4-13
	Main Circuit Wiring.....	4-15
<b>4-3</b>	<b>Wiring Conforming to EMC Directives .....</b>	<b>4-17</b>
	Wiring Method.....	4-17
	Control Panel Structure.....	4-19
	Selecting Connection Components.....	4-21
<b>4-4</b>	<b>Regenerative Energy Absorption .....</b>	<b>4-32</b>
	Calculating the Regenerative Energy .....	4-32
	Servo Drive Regenerative Energy Absorption Capacity .....	4-34
	Absorbing Regenerative Energy with an External Regeneration Resistor .....	4-34

---

# 4-1 Installation Conditions

---

## Servo Drives

### ■ Space around Drives

- ♦ Install Servo Drives according to the dimensions shown in the following illustration to ensure proper heat dispersion and convection inside the panel. Also if the Servo Drives are installed side by side, install a fan for air circulation to prevent uneven temperatures from developing inside the panel.

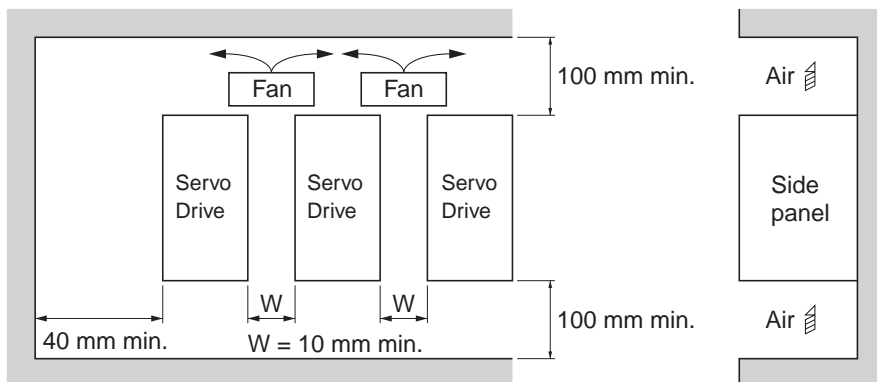

### ■ Mounting Direction

- ♦ Mount the Servo Drives in a direction (perpendicular) so that the model number can be seen properly.

### ■ Operating Environment

- ♦ The environment in which Servo Drives are operated must meet the following conditions. Servo Drives may malfunction if operated under any other conditions.
  - Ambient operating temperature: 0 to 55°C (Take into account temperature rises in the individual Servo Drives themselves.)
  - Ambient operating humidity: 90% RH max. (with no condensation)
  - Atmosphere: No corrosive gases.

---

**■ Ambient Temperature Control**

- ♦ Servo Drives should be operated in environments in which there is minimal temperature rise to maintain a high level of reliability.
- ♦ Temperature rise in any Unit installed in a closed space, such as a control box, will cause the Servo Drive's ambient temperature to rise. Use a fan or air conditioner to prevent the Servo Drive's ambient temperature from exceeding 55°C.
- ♦ Servo Drive surface temperatures may rise to as much as 30°C above the ambient temperature. Use heat-resistant materials for wiring, and keep its distance from any devices or wiring that are sensitive to heat.
- ♦ The service life of a Servo Drive is determined by the temperature around the internal electrolytic capacitors. The service life of an electrolytic capacitor is affected by a drop in electrostatic capacity and an increase in internal resistance, which can result in overvoltage alarms, malfunctioning due to noise, and damage to individual elements.
- ♦ If a Servo Drive is operated at the ambient temperature of 55°C with the rated torque output and rated rotation speed, its service life is expected to be approximately 28,000 hours (excluding axial-flow fan). A drop of 10°C in the ambient temperature will double the expected service life.

**■ Keeping Foreign Objects Out of Units**

- ♦ Place a cover over the Units or take other preventative measures to prevent foreign objects, such as drill filings, from getting into the Units during installation. Be sure to remove the cover after installation is complete. If the cover is left on during operation, Servo Drive's heat dissipation is blocked, which may result in malfunction.
- ♦ Take measures during installation and operation to prevent foreign objects such as metal particles, oil, machining oil, dust, or water from getting inside of Servo Drives.

Servomotors

■ Operating Environment

- ♦ The environment in which the Servomotor is operated must meet the following conditions. Operating the Servomotor outside of the following ranges may result in malfunction of the Servomotor.
  - Ambient operating temperature: 0 to 40°C
  - Ambient operating humidity: 85% RH max. (with no condensation)
  - Atmosphere: No corrosive gases.

■ Impact and Load

- ♦ The Servomotor is resistant to impacts of up to 98 m/s<sup>2</sup>. Do not apply heavy impacts or loads during transportation, installation, or removal.
- ♦ When transporting, hold the Servomotor body itself, and do not hold the Encoder, Cable, or connector areas. Doing so may damage the Servomotor.
- ♦ Always use a pulley remover to remove pulleys, couplings, or other objects from the shaft.
- ♦ Secure cables so that there is no impact or load placed on the cable connector areas.

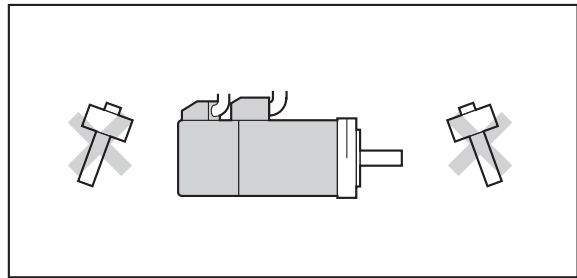

■ Connecting to Mechanical Systems

- ♦ The axial loads for Servomotors are specified in *Characteristics* on page 3-17. If an axial load greater than that specified is applied to a Servomotor, it will reduce the service life of the motor bearings and may break the motor shaft.
- ♦ When connecting to a load, use couplings that can sufficiently absorb mechanical eccentricity and declination.
- ♦ For spur gears, an extremely large radial load may be applied depending on the gear precision. Use spur gears with a high degree of precision (for example, JIS class 2: normal line pitch error of 6 μm max. for a pitch circle diameter of 50 mm).
- ♦ If the gear precision is not adequate, allow backlash to ensure that no radial load is placed on the motor shaft.
- ♦ Bevel gears will cause a load to be applied in the thrust direction depending on the structural precision, the gear precision, and temperature changes. Provide appropriate backlash or take other measures to ensure that a thrust load larger than the specified level is not applied.
- ♦ Do not put rubber packing on the flange surface. If the flange is mounted with rubber packing, the motor flange may crack under the tightening force.

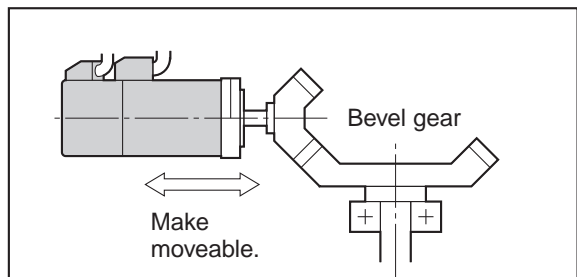
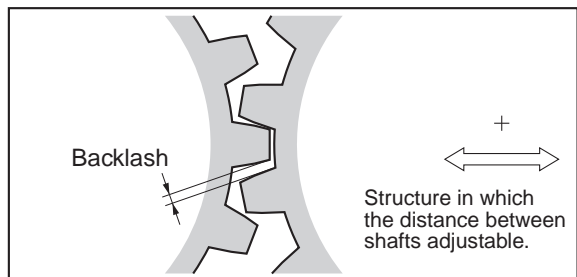
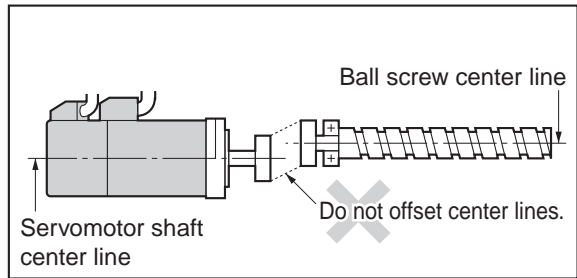

- ♦ When connecting to a V-belt or timing belt, consult the maker for belt selection and tension.
- ♦ A radial load twice the belt tension will be placed on the motor shaft. Do not allow a radial load exceeding specifications to be placed on the motor shaft. If an excessive radial load is applied, the motor shaft and bearings may be damaged.
- ♦ Set up a structure so that the belt tension can be adjusted.

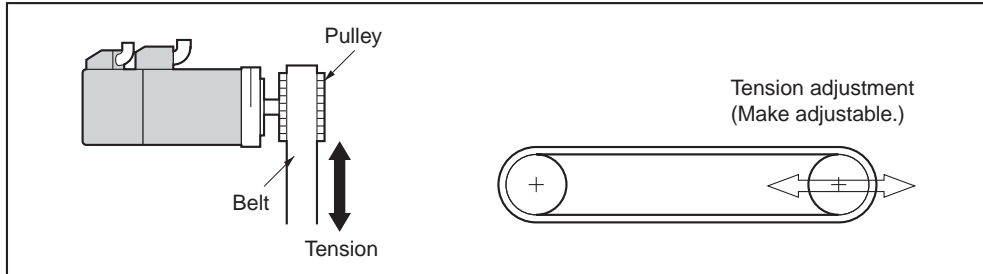

■ Water and Drip Resistance

- ♦ The protective structure for the Servomotors is as follows:  
IP65 (except for through-shaft parts and cable outlets)

■ Oil Seal Part Number

With OMNUC G-Series Servomotors, an oil seal can be installed afterwards. Refer to the installation instructions from NOK Corporation for information on installing the oil seal. The following oil seals are not standard NOK products. Check with the manufacturer. The expected service life of the oil seals is approximately 5,000 hours, but the actual life depends on the application conditions and environment.

Motor model	Shaft diameter (mm)	Outer diameter (mm)	Width (mm)	Material (rubber)	NOK part number (SC type)
R88M-G05030L/H	8.9	17	4	A435	BC6646-E0
R88M-G10030L/H	8.9	17	4	A435	BC6646-E0
R88M-G20030L/H	14	28	4	A435	BC5102-E1
R88M-G40030H	14	28	4	A435	BC5102-E1
R88M-GP10030L/H	8.9	22	4	A435	BC5101-E1
R88M-GP20030L/H	14	28	4	A435	BC5102-E1
R88M-GP40030H	14	28	4	A435	BC5102-E1

■ Other Precautions

- ♦ Take measures to protect the shaft from corrosion. The shafts are coated with anti-corrosion oil when shipped, but anti-corrosion oil or grease should also be applied when connecting the shaft to a load.

WARNING

	Do not apply commercial power directly to the Servomotor. Doing so may result in fire.
	Do not dismantle or repair the product. Doing so may result in electric shock or injury.

## Decelerators

### ■ Installing Decelerators

- ♦ Use only the specified combinations of Servomotors and Decelerators. (Refer to *Decelerator Specifications* on page 3-26.) The service life of the motor bearings may be shortened if you use a combination that is not specified, another company's decelerator, or another company's servomotor.
- ♦ The dimensions of the Servomotor mounting flange on the Decelerators differ for each Servomotor. Do not install a Decelerator on a Servomotor other than the one specified.
- ♦ Use the following procedure when installing a Decelerator on the Servomotor.
- ♦ When installing the Servomotor, avoid the Servomotor shaft's key groove when installing the set bolt.

### ■ Installing an R88G-HPG□ (Backlash = 3' Max.)

Use the following procedure to install the Decelerator on the Servomotor.

- 1. Turn the input joint and align the head of the bolt that secures the shaft with the rubber cap.**
- 2. Apply sealant to the installation surface on the Servomotor (recommended sealant: Loctite 515).**
- 3. Gently insert the Servomotor into the Decelerator.**  
As shown in the figures on the next page, stand the Decelerator upright and slide down the Servomotor shaft into the input shaft joint while making sure it does not fall over. If the Decelerator cannot be stood upright, tighten each bolt evenly little by little to ensure that the Servomotor is not inserted at a tilt.
- 4. Bolt together the Servomotor and the Decelerator flanges.**

Bolt Tightening Torque for Aluminum

Allen head bolt size	Tightening torque (N·m)
M4	3.2
M5	6.3
M6	10.7

- 5. Tighten the input joint bolt.**

Bolt Tightening Torque for Duralumin

Allen head bolt size	Tightening torque (N·m)
M4	2.0
M5	4.5

**Note** Always use the torque given in the table above. The Servomotor may slip or other problems may occur if the specified torque level is not satisfied.

The R88G-HPG11A□ uses two set screws for the connecting section.

Allen head bolt size	Tightening torque (N·m)
M3	0.69

- 6. Mount the supplied rubber cap to complete the installation procedure.**  
(For the R88G-HPG11A□, mount two screws with gaskets.)

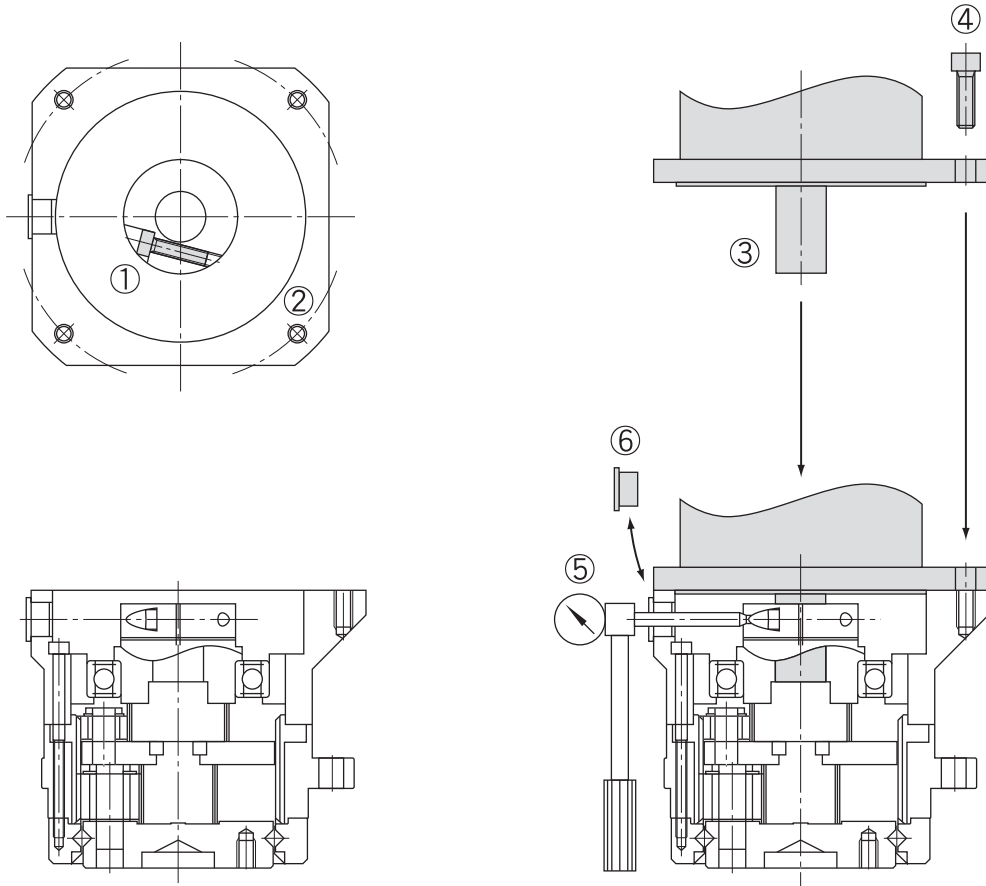

**Installing the Decelerator**

When installing the R88G-HPG□, first make sure that the mounting surface is flat and that there are no burrs on the tap sections, and then bolt on the mounting flanges.

Mounting Flange Bolt Tightening Torque for Aluminum

Decelerator model	Number of bolts	Bolt size	Mounting PCD (mm)	Tightening torque (N·m)
R88G-HPG11A□	4	M3	46	1.4
R88G-HPG14A□	4	M5	70	6.3
R88G-HPG20A□	4	M8	105	26.1
R88G-HPG32A□	4	M10	135	51.5

## 4-1 Installation Conditions

### ■ Installing an R88G-VRSF□ (Backlash = 15' Max.)

Use the following procedure to install the Decelerator to the Servomotor.

**1. Turn the input joint and align the head of the bolt that secures the shaft with the rubber cap.**

Make sure the set bolts are loosened.

**2. Gently insert the Servomotor into the Decelerator.**

As shown in the figures on the next page, stand the Decelerator upright and slide down the Servomotor shaft into the input shaft joint while making sure it does not fall over. If the Decelerator cannot be stood upright, tighten each bolt evenly little by little to ensure that the Servomotor is not inserted at a tilt.

**3. Bolt together the Servomotor and the Decelerator flanges.**

Bolt Tightening Torque

Allen head bolt size	Tightening torque (N·m)
M4	3.0
M5	5.8
M6	9.8

**4. Tighten the input joint bolt.**

Bolt Tightening Torque

Allen head bolt size	Tightening torque (N·m)
M3	1.5
M4	3.5
M5	7.1

**Note** Always use the torque given in the table above. Sliding or other problems may occur if the specified torque level is not satisfied.

**5. Mount the supplied rubber cap to complete the installation procedure.**



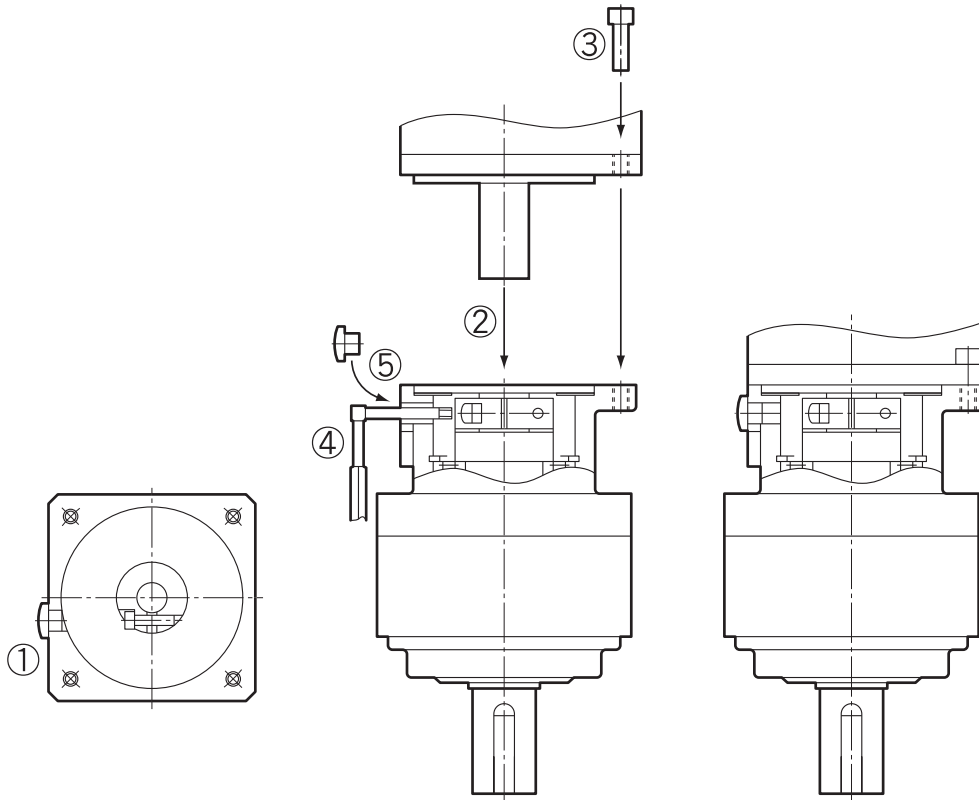

### Installing the Decelerator

When installing the R88G-VRSF□, first make sure that the mounting surface is flat and that there are no burrs on the tap sections, and then bolt on the mounting flanges.

Mounting Flange Bolt Tightening Torque for Aluminum

Decelerator model R88G-VRSF	Number of bolts	Bolt size	Mounting PCD (mm)	Tightening torque (N·m)
B frame	4	M5	60	5.8
C frame	4	M6	90	9.8

### ■ Using Another Company's Decelerator (Reference Information)

If the system configuration requires another company's decelerator to be used in combination with an OMNUC G-Series Servomotor, select the decelerator so that the load on the motor shaft (i.e., both the radial and thrust loads) is within the allowable range.

(Refer to *Characteristics* on page 3-17 for details on the allowable loads for the motors.)

Also, select the decelerator so that the allowable input rotation speed and allowable input torque of the decelerator are not exceeded.

# 4-2 Wiring

## Connecting Cables

This section shows the types of connecting cables used in a SMARTSTEP 2 system. A wide selection of cables are available when using Position Control Units for OMRON SYSMAC PLCs, making it easy to wire a servo system.

### System Configuration

4

System Design

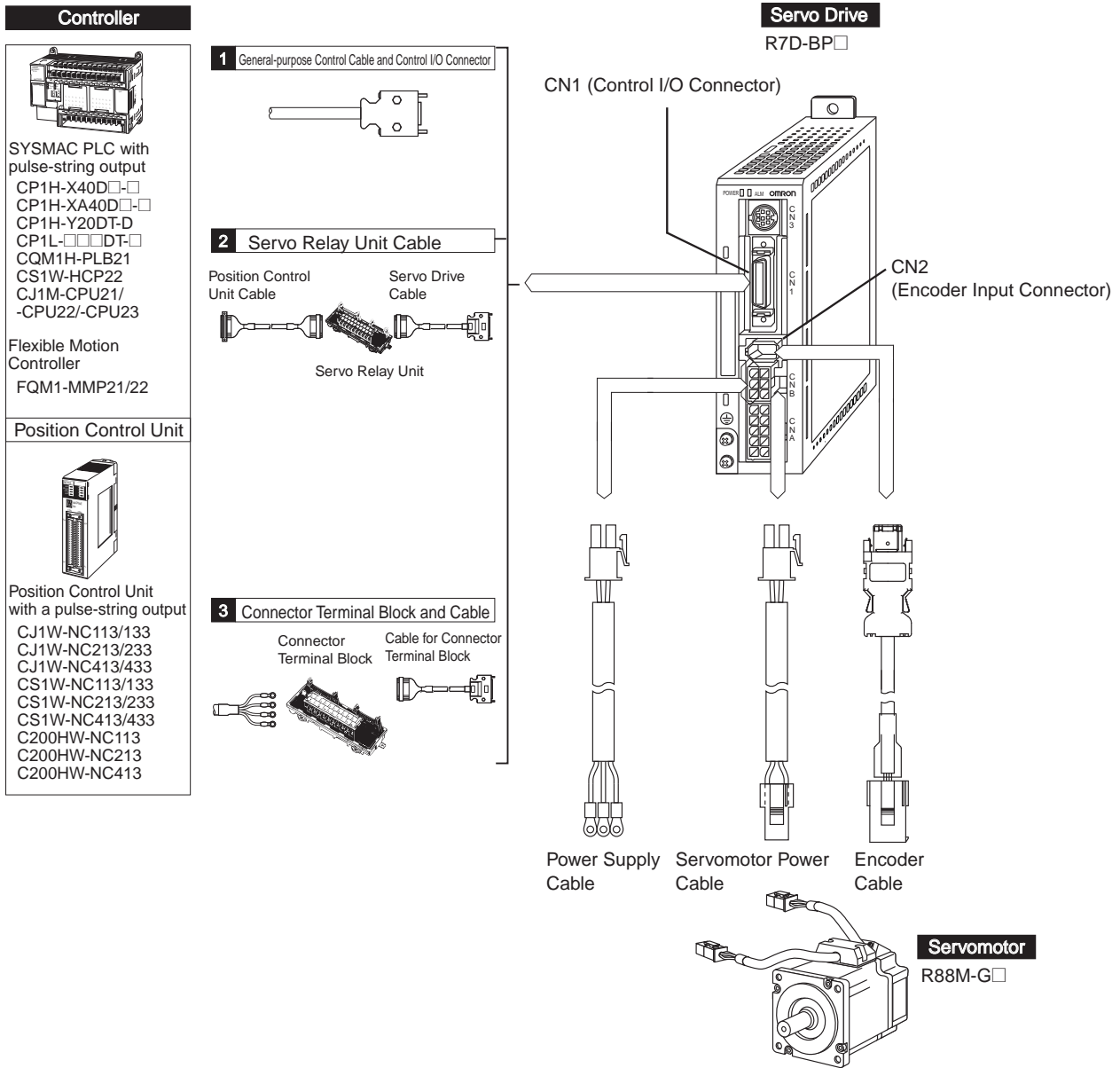

## Selecting Connecting Cables

### ■ Encoder Cables (CN2)

Name	Model	Comments
Standard Cables for Encoders	R88A-CRGB□□□C	The □□□ digits in the model number indicate the cable length (3 m, 5 m, 10 m, 15 m, or 20 m). Example model number for a 3-m cable: R88A-CRGB003C
Robot Cables for Encoders	R88A-CRGB□□□CR	The □□□ digits in the model number indicate the cable length (3 m, 5 m, 10 m, 15 m, or 20 m). Example model number for a 3-m cable: R88A-CRGB003CR

### ■ Servomotor Power Cables (CNB)

Name	Model	Comments
Standard Cables for Servomotor Power	R7A-CAB□□□S	The □□□ digits in the model number indicate the cable length (3 m, 5 m, 10 m, 15 m, or 20 m). Example model number for a 3-m cable: R7A-CAB003S
Robot Cables for Servomotor Power	R7A-CAB□□□SR	The □□□ digits in the model number indicate the cable length (3 m, 5 m, 10 m, 15 m, or 20 m). Example model number for a 3-m cable: R7A-CAB003SR

### ■ Brake Cables

Name	Model	Comments
Standard Cables for Brakes	R88A-CAGA□□□B	The □□□ digits in the model number indicate the cable length (3 m, 5 m, 10 m, 15 m, or 20 m). Example model number for a 3-m cable: R88A-CAGA003B
Robot Cables for Brakes	R88A-CAGA□□□BR	The □□□ digits in the model number indicate the cable length (3 m, 5 m, 10 m, 15 m, or 20 m). Example model number for a 3-m cable: R88A-CAGA003BR

### ■ Power Supply Cables (CNA)

Name	Model	Comments
Cable for Single-phase Power Supply Input	R7A-CLB002S2	Cable length: 2 m
Cable for Three-phase Power Supply Input	R7A-CLB002S3	Cable length: 2 m
Cable for Connecting to External Regeneration Resistor	R7A-CLB002RG	Cable length: 2 m

## 4-2 Wiring

### ■ Servo Relay Units and Cables

Select the Servo Relay Unit and Cable according to the model of the Position Control Unit to be used.

Position Control Unit	Position Control Unit Cable		Servo Relay Unit	Servo Drive Cable
CJ1W-NC133	XW2Z-□□□J-A18		XW2B-20J6-1B	XW2Z-□□□J-B29
CJ1W-NC233	XW2Z-□□□J-A19		XW2B-40J6-2B	
CJ1W-NC433				
CS1W-NC133	XW2Z-□□□J-A10		XW2B-20J6-1B	
CS1W-NC233	XW2Z-□□□J-A11		XW2B-40J6-2B	
CS1W-NC433				
CJ1W-NC113	XW2Z-□□□J-A14		XW2B-20J6-1B	
CJ1W-NC213	XW2Z-□□□J-A15		XW2B-40J6-2B	
CJ1W-NC413				
CS1W-NC113	XW2Z-□□□J-A6		XW2B-20J6-1B	
C200HW-NC113				
CS1W-NC213	XW2Z-□□□J-A7		XW2B-40J6-2B	
CS1W-NC413				
C200HW-NC213				
C200HW-NC413				
CJ1M-CPU21	XW2Z-□□□J-A33		XW2B-20J6-8A XW2B-40J6-9A (for 2 axes)	XW2Z-□□□J-B32
CJ1M-CPU22				
CJ1M-CPU23				
FQM1-MMP22	General-purpose I/O Cable	XW2Z-□□□J-A28	XW2B-80J7-12A	XW2Z-□□□J-B30
	Special I/O Cable	XW2Z-□□□J-A30		
CQM1H-PLB21	XW2Z-□□□J-A3		XW2B-20J6-3B	XW2Z-□□□J-B29
CQM1-CPU43-V1				

**Note 1.** The cable length is indicated in the boxes of the model number (□□□). Position Control Unit cables come in two lengths: 0.5 m and 1 m (some 2-m cables are also available). Servo Drive Cables also come in two lengths: 1 m and 2 m. For information on cable lengths, refer to *Accessories and Cables* on page 2-8.

**Note 2.** Two Servo Drive Cables are required if 2-axis control is performed using one Position Control Unit.

### ■ Connector-Terminal Block Conversion Units and Cables

These Conversion Units and Cables are used for connecting to Controllers for which no specific cable is available. The Cables and Connector-Terminal Block Unit convert the Servo Drive's control I/O Connector (CN1) signals to a terminal block.

Name	Model	Comments
Connector-Terminal Block Conversion Unit	XW2B-34G4	Terminal block with M3 screws
	XW2B-34G5	Terminal block with M3.5 screws
	XW2D-34G6	Terminal block with M3 screws
Connector-Terminal Block Cable	XW2Z-□□□J-B28	This cable is used to connect a Connector-Terminal Block Conversion Unit. The cable length is indicated in the boxes of the model number (□□□). There are two cable lengths: 1 m and 2 m. Model number example for 1-m cable: XW2Z-100J-B28

### ■ General-purpose Control Cables (CN1)

A General-purpose Control Cable is used to prepare a cable by yourself to connect to the Servo Drive's Control I/O Connector (CN1).

Name	Model	Comments
General-purpose Control Cable	R7A-CPB□□□S	One end of the cable has loose wires. The □□□ digits in the model number indicate the cable length (1 m or 2 m). Example model number for 1-m cable: R7A-CPB001S

## Peripheral Device Connection Examples

### ■ R7D-BPA5L/-BP01L/-BP02L/-BP04L/-BP01H/-BP02HH/-BP04H

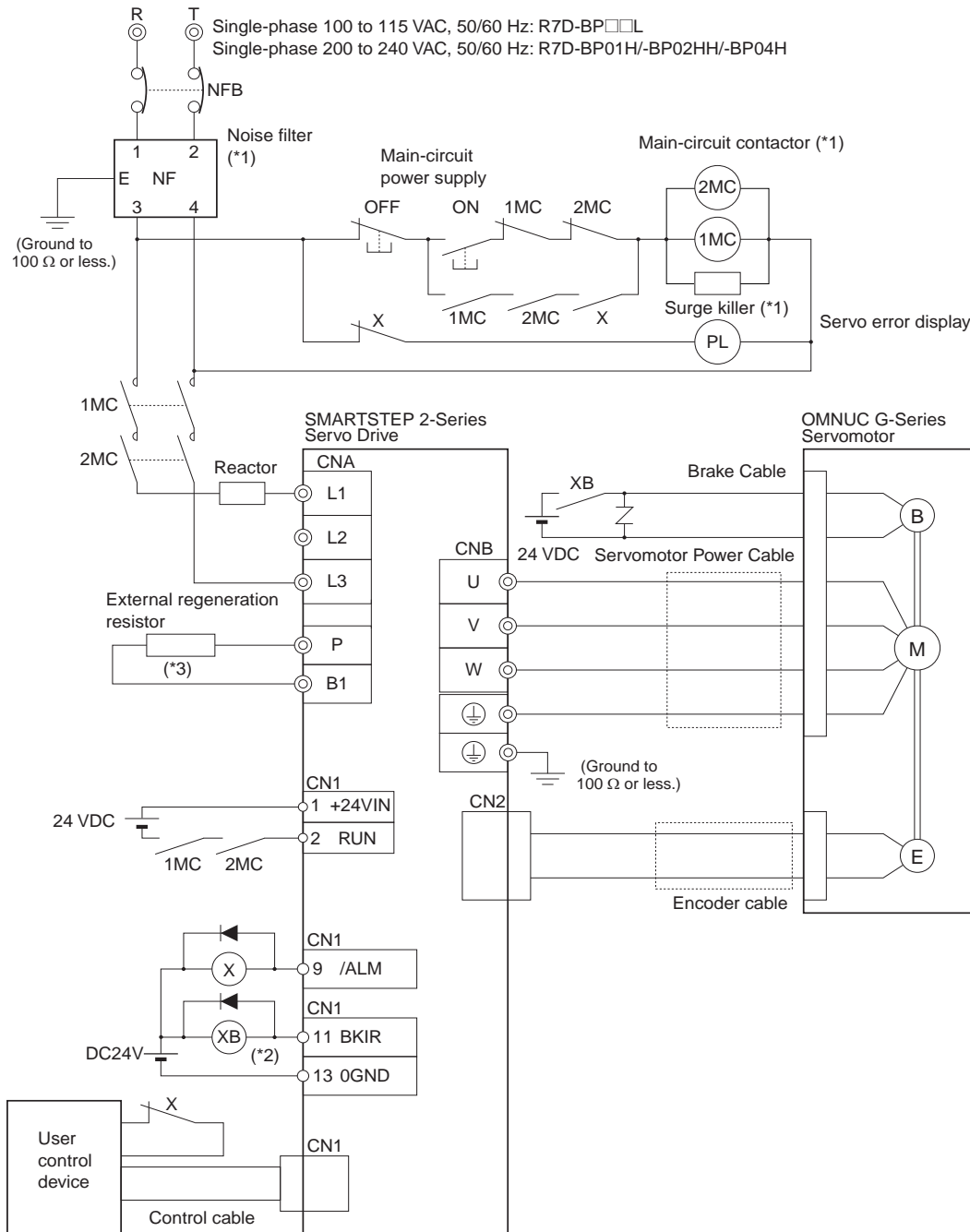

\*1. Recommended products are listed in 4-3 *Wiring Conforming to EMC Directives*.

\*2. Recommended Relay: OMRON G7T Relay (24-VDC model)

\*3. An External Regeneration Resistor can be connected.

Connect this resistor if the regenerative energy exceeds regeneration absorption capacity in the Servo Drive. (Refer to *Servo Drive Regenerative Energy Absorption Capacity* on page 4-34.)

**Note 1.** The dynamic brake operates when the main circuit power supply or the control circuit power supply is turned OFF.

**Note 2.** When turning OFF the main circuit power supply, turn OFF the RUN Command Input (RUN) signal at the same time.

■ R7D-BP01H/-BP02H/-BP04H

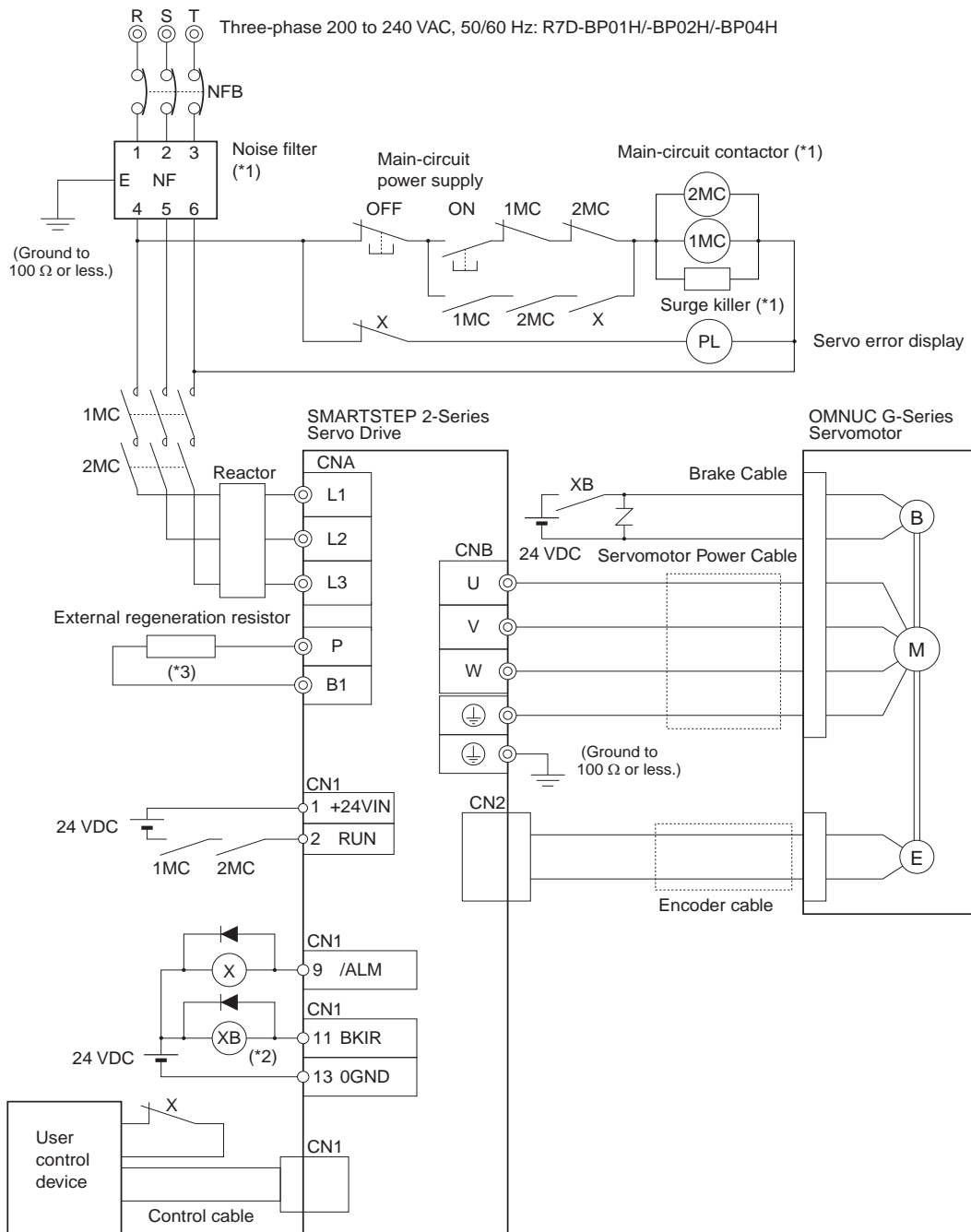

\*1. Recommended products are listed in 4-3 *Wiring Conforming to EMC Directives*.

\*2. Recommended Relay: OMRON G7T Relay (24-VDC model)

\*3. An External Regeneration Resistor can be connected.

Connect this resistor if the regenerative energy exceeds regeneration absorption capacity in the Servo Drive. (Refer to *Servo Drive Regenerative Energy Absorption Capacity* on page 4-34.)

**Note 1.** The dynamic brake operates when the main circuit power supply or the control circuit power supply is turned OFF.

**Note 2.** When turning OFF the main circuit power supply, turn OFF the RUN Command Input (RUN) signal at the same time.

## Main Circuit Wiring

When wiring a Terminal Block, use proper wire sizes, grounding systems, and take into account anti-noise characteristics.

### ■ Terminal Names and Functions

Signal	Name	Function
L1	Main circuit power supply input	Single-phase 100 to 115 VAC (85 to 126 VAC), 50/60 Hz Single-phase/three-phase 200 to 230 VAC (170 to 264 VAC), 50/60 Hz
L2		
L3		
P	External regeneration resistor connection terminals	If regenerative energy is high, connect an External Regeneration Resistor.
B1		
⊕	Frame ground	This is the ground terminal. Ground to 100 Ω or less.

### ■ Terminal Wire Sizes

Item	Unit	R7D-BPA5L	R7D-BP01L	R7D-BP02L	
Power supply capacity	kVA	0.16	0.25	0.42	
Main circuit power supply input (L1, L2)	Rated current	A(rms)	1.4	2.2	3.7
	Wire size		AWG18		
External Regeneration Resistor connection (+, -)	Wire size		AWG18		
Servomotor connection terminal (U, V, W, ⊕) <sup>*1</sup>	Rated current	A(rms)	1.0	1.6	2.5
	Maximum momentary current	A(rms)	3.3	5.1	7.5
	Wire size		AWG18		
Frame ground	Wire size		AWG14 min.		
	Screw size	---	M4		
	Torque	N·m	1.2 to 1.4		
No-fuse breaker or fuse capacity <sup>*2</sup>	A(rms)	3	5	7	

\*1. Connect an OMRON Servomotor Power Cable to the Servomotor connection terminals.

\*2. Use a no fuse breaker or a surge withstand fuse. The maximum inrush current is 20 A.



Item		Unit	R7D-BP01H	R7D-BP02HH	R7D-BP02H	R7D-BP04H
Power supply capacity		kVA	0.27 (0.3) <sup>*1</sup>	0.35	0.42	0.69 (0.77) <sup>*1</sup>
Main circuit power supply input (L1, L2)	Rated current	A(rms)	0.7 (1.5) <sup>*1</sup>	1.6	1.1	1.8 (3.5) <sup>*1</sup>
	Wire size		AWG18			
External Regeneration Resistor connection (+, -)	Wire size		AWG18			
Servomotor connection terminal (U, V, W, ⊕) <sup>*2</sup>	Rated current	A(rms)	1.0	1.6	1.6	2.5
	Maximum momentary current	A(rms)	3.3	4.9	4.9	7.8
	Wire size		AWG18			
Frame ground	Wire size		AWG14 min.			
	Screw size	---	M4			
	Torque	N·m	1.2 to 1.4			
No-fuse breaker or fuse capacity <sup>*3</sup>		A(rms)	3	2	2	5 (7) <sup>*1</sup>

\*1. Values in parentheses ( ) are for using single-phase 200 V.

\*2. Connect an OMRON Servomotor Power Cable to the Servomotor connection terminals.

\*3. Use a no fuse breaker or a surge withstand fuse. The maximum inrush current is 20 A.

### ■ Wire Size and Allowable Current (Reference)

The following table shows the allowable current when there are three power supply wires. Use a current below these specified values.

#### 600-V Heat-resistant Vinyl Wire (HIV)

AWG size	Nominal cross-sectional area (mm <sup>2</sup> )	Configuration (wires/mm <sup>2</sup> )	Conductive resistance (Ω/km)	Allowable current (A) for ambient temperature		
				30°C	40°C	50°C
20	0.5	19/0.18	39.5	6.6	5.6	4.5
---	0.75	30/0.18	26.0	8.8	7.0	5.5
18	0.9	37/0.18	24.4	9.0	7.7	6.0
16	1.25	50/0.18	15.6	12.0	11.0	8.5
14	2.0	7/0.6	9.53	23	20	16

## 4-3 Wiring Conforming to EMC Directives

Conformance to the EMC Directives (EN55011 class A group 1 (EMI) and EN61000-6-2 (EMS)) can be ensured by wiring under the conditions described below. These conditions are for conformance of the SMARTSTEP-2 products to the EMC Directives.

EMC-related performance of these products, however, will vary depending on the configuration, wiring, and other conditions of the equipment in which the products are installed. The EMC conformance of the system as a whole must be confirmed by the customer.

The following are the requirements for EMC Directive conformance.

- ♦ The Servo Drive must be installed in a metal case (control panel). (The Servomotor does not, however, have to be covered with a metal plate.)
- ♦ Noise filters and surge absorbers must be installed on power supply lines.
- ♦ Shielded cables must be used for all I/O signal lines and encoder lines. (Use tin-plated, mild steel wires for the shielding.)
- ♦ All cables, I/O wiring, and power lines connected to the Servo Drive must have clamp filters installed.
- ♦ The shields of all cables must be directly connected to a ground plate.

### Wiring Method

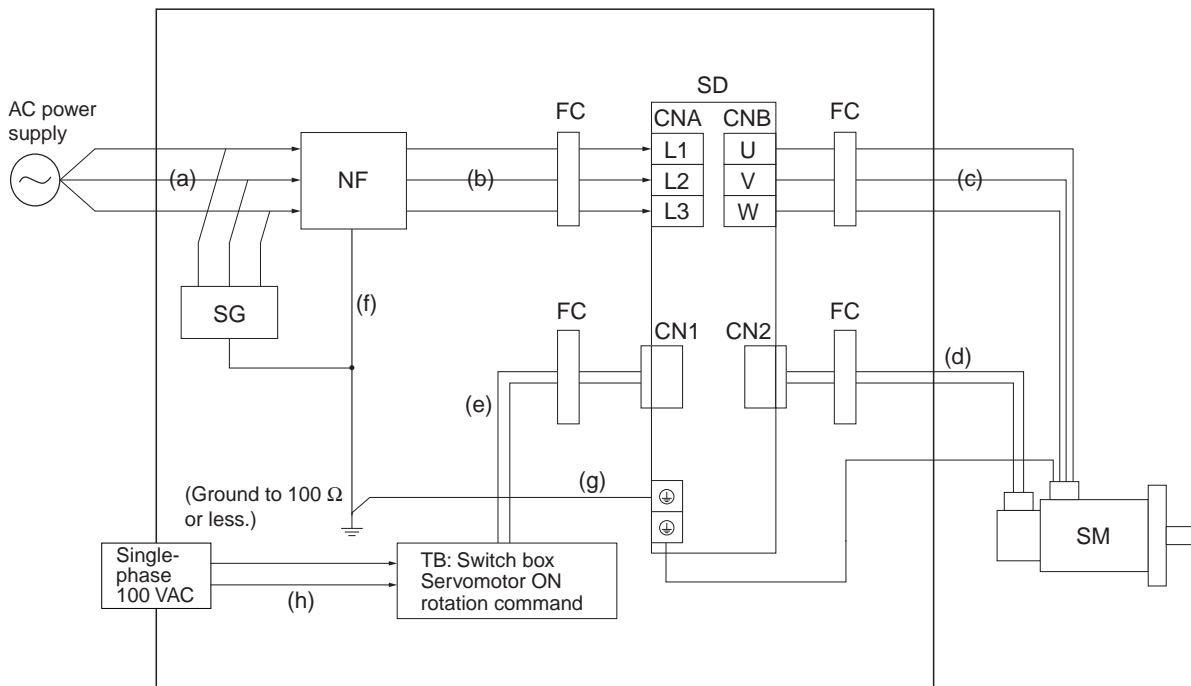

**Note** For models with a single-phase power supply input (R7D-BP□□L/-BP01H/BP02HH/-BP04H), the main input power supply terminals are L1 and L3.

- ♦ Ground the motor's frame to the machine ground when the motor is on a movable shaft.
- ♦ Use a ground plate for the frame ground for each Unit, as shown in the above diagrams, and ground to a single point.
- ♦ Use ground lines with a minimum thickness of 3.5 mm<sup>2</sup>, and arrange the wiring so that the ground lines are as short as possible.
- ♦ No-fuse breakers, surge absorbers, and noise filters should be positioned near the input terminal block (ground plate), and I/O lines should be separated and wired at the shortest distance.

### ■ Unit Details

Symbol	Name	Manufacturer	Model	Remarks
SG	Surge absorber	Okaya Electric Industries Co., Ltd.	RAV781BWZ-4	Single-phase 100 VAC
			RAV781BXZ-4	Three-phase 200 VAC
NF	Noise filter	Okaya Electric Industries Co., Ltd.	3SUP-HQ10-ER-6	Single-phase 100/200 VAC
SD	Servo Drive	OMRON Corp.	R7D-BP02L	Single-phase 100 VAC
			R7D-BP04H	Three-phase 200 VAC
SM	Servomotor	OMRON Corp.	R88M-G20030L	100 VAC
			R88M-G40030H	200 VAC
FC	Clamp core	TDK	ZACT305-1330	
TB	Switch box			

### ■ Cable Details

Symbol	Supplies from	Connects to	Cable name	Length	Remarks	Shielded	Ferrite
(a)	AC power supply	Noise filter	Power supply line	2 m	Single-phase 100 VAC	No	No
				3 m	Three-phase 200 VAC	No	No
(b)	Noise filter	Servo Drive	Power supply line	2 m	---	No	Yes
(c)	Servo Drive	Servomotor	Power cable	20 m	---	Yes	Yes
(d)	Servo Drive	Servomotor	Encoder cable	20 m	---	No	Yes
(e)	Switch box	Servo Drive	I/O cable	1 m	---	No	Yes
(f)	Frame ground	Noise filter	Frame ground line	1.5 m	---	No	No
(g)	Frame ground	Noise filter	Frame ground line	1.5 m	---	No	No
(h)	AC power supply	Switch box	Power supply line	1.5 m	---	No	No

## 4-3 Wiring Conforming to EMC Directives

- ♦ If no-fuse breakers are installed at the top and the power supply line is wired from the lower duct, use metal tubes for wiring or make sure that there is adequate distance between the input lines and the internal wiring. If input and output lines are wired together, noise resistance will decrease.
- ♦ Wire the noise filter as shown at the left in the following illustration. The noise filter must be installed as close as possible to the entrance of the control box.

### ○ Correct: Separate input and output

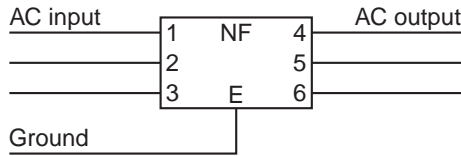

### ✗ Wrong: Noise not filtered effectively

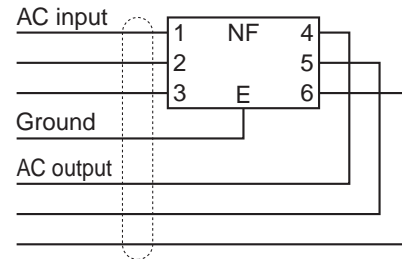

- ♦ Use twisted-pair cables for the power supply cables, or bind the cables.

### ○ Correct: Properly twisted

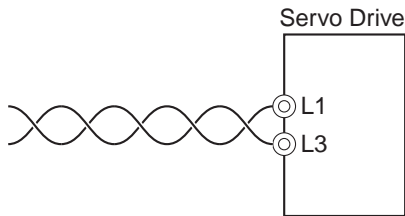

### ○ Correct: Cables are bound.

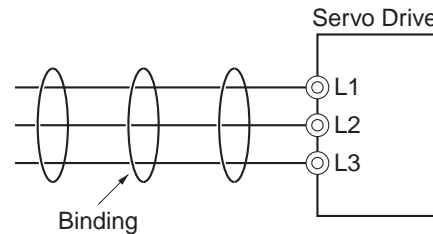

- ♦ Separate power supply cables and signal cables when wiring.

## Control Panel Structure

Openings in the control panel, such as holes for cables, operating panel mounting holes, and gaps around the door, may allow electromagnetic waves into the panel. To prevent this from occurring, observe the items described below when designing or selecting a control panel.

### ■ Case Structure

- ♦ Use a metal control panel with welded joints at the top, bottom, and sides so that the surfaces will be electrically conductive.
- ♦ If assembly is required, strip the paint off the joint areas (or mask them during painting), to make them electrically conductive.
- ♦ If gaps appear in the control box case when screws are tightened, make adjustments to prevent this from occurring.
- ♦ Do not leave any conductive part unconnected.
- ♦ Ground all Units within the case to the case itself.

■ Door Structure

- ♦ Use a metal door.
- ♦ Use a water-draining structure where the door and case fit together, and leave no gaps. (Refer to the diagrams below.)
- ♦ Use a conductive gasket between the door and the case, as shown in the diagrams below. (Refer to the diagrams below.)
- ♦ Strip the paint off the sections of the door and case that will be in contact with the conductive gasket (or mask them during painting), so that they will be electrically conductive.
- ♦ The door may warp and gaps may appear between the door and case when screws are tightened. Be sure that no gaps appear when tightening screws.

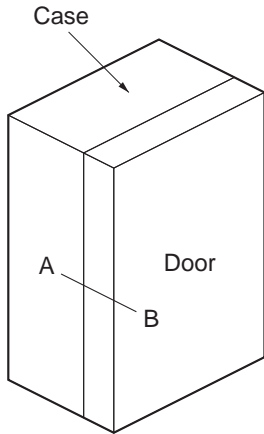

Control panel

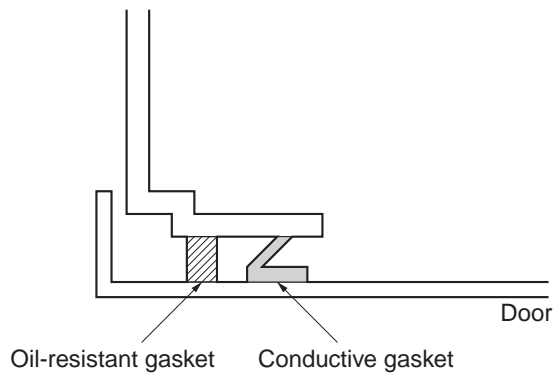

Cross-sectional view of A-B

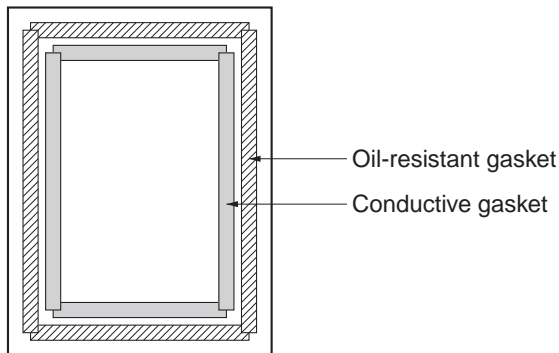

Door (interior view)

### Selecting Connection Components

This section explains the criteria for selecting the connection components required to improve noise resistance. Understand each component's characteristics, such as its capacity, performance, and applicable conditions when selecting the components. For more details, contact the manufacturers directly.

#### ■ No-fuse Breakers (NFB)

When selecting a no-fuse breaker, consider the maximum input current and the inrush current.

##### Maximum Input Current:

- ♦ The Servo Drive's maximum momentary output is approximately three times the rated output, and can be output for up to three seconds. Therefore, select a no-fuse breaker with an operating time of at least five seconds at 300% of the rated current. General-purpose and low-speed no-fuse breakers are generally suitable.
- ♦ Select a no-fuse-breaker with a rated current greater than the total effective load current of all the Servomotors. The rated current of the power supply input for each Servomotor is provided in *Main Circuit Wiring* on page 4-15.
- ♦ Add the current consumption of other controllers, and any other components, when selecting the NFB.

##### Inrush Current:

- ♦ The following table lists the Servo Drive inrush currents.
- ♦ With low-speed no-fuse breakers, an inrush current 10 times the rated current can flow for 0.02 second.
- ♦ When multiple Servo Drives are turned ON simultaneously, select a no-fuse-breaker with a 20-ms allowable current that is greater than the total inrush current shown in the following table.

Servo Drive model	Inrush current (A0-p)
	Main circuit power supply
R7D-BP Series	20

## ■ Leakage Breakers

The leakage current for the Servomotor and Servo Drive combinations are given in the following table.

R7D-BP Series		Resistor + capacitor measurement	Clamp leak tester (measurement filter ON with HIOKI 3283)	
		5-m power cable	5-m power cable	20-m power cable
Servo Drive model	Specifications	Leakage current (mA)	Leakage current (mA)	Leakage current (mA)
R7D-BPA5L	Single-phase 100 V, 50 W	0.48	0.08	0.13
R7D-BP01L	Single-phase 100 V, 100 W	0.59	0.09	0.13
R7D-BP02L	Single-phase 100 V, 200 W	0.50	0.10	0.15
R7D-BP01H	Single/three-phase 200 V, 50 W	0.91	0.25	0.37
	Single/three-phase 200 V, 100 W	1.18	0.18	0.29
R7D-BP02HH	Single-phase 200 V, 200 W	0.95	0.30	0.40
R7D-BP02H	Three-phase 200 V, 200 W	1.17	0.26	0.37
R7D-BP04H	Single/three-phase 200 V, 400 W	1.25	0.55	0.72

**Note 1.** The resistor plus capacitor measurement provides a guide to the leakage current level that may flow through people if the Servomotor and Servo Drive are not properly grounded. The actual value changes depending on the ambient temperature and humidity.

**Note 2.** The clamp leak tester measurement is the leakage current actually detected at the inverter and surge-resistant leakage breaker. Triple this value when using a general leakage breaker.

### Actual Selection

- ♦ The leakage breaker starts to detect leakage current from 50% of the rated leakage current, so provide a margin of two times.
- ♦ Also, a large amount of leakage current will flow from the noise filter. Leakage current from other Controllers should also be added to the total leakage current.
- ♦ To prevent incorrect operation due to inrush current, it is necessary to select a current value of ten times the total leakage current for uses other than surge resistance.
- ♦ Refer to the specifications from the relevant manufacturer for information on leakage breakers.

## 4-3 Wiring Conforming to EMC Directives

### ■ Surge Absorbers

- ♦ Use surge absorbers to absorb lightning surge voltage or abnormal voltage from power supply input lines.
- ♦ When selecting surge absorbers, take into account the varistor voltage, the allowable surge current, and the energy.
- ♦ For 200-VAC systems, use surge absorbers with a varistor voltage of 620 V.
- ♦ The surge absorbers shown in the following table are recommended.

Maker	Model	Max. limit voltage	Surge immunity	Type	Remarks
Okaya Electric Industries Co., Ltd.	R·A·V·781BWZ-4	700 V ±20%	2500 A	Block	Single-phase 100/200 VAC
	R·A·V·781BXZ-4	700 V ±20%	2500 A		Three-phase 200 VAC

**Note 1.** Refer to the manufacturers' documentation for operating details.

**Note 2.** The surge immunity is for a standard impulse current of  $8/20 \mu\text{s}$ . If pulses are wide, either decrease the current or change to a larger-capacity surge absorber.

### Dimensions

Single-phase BWZ Series

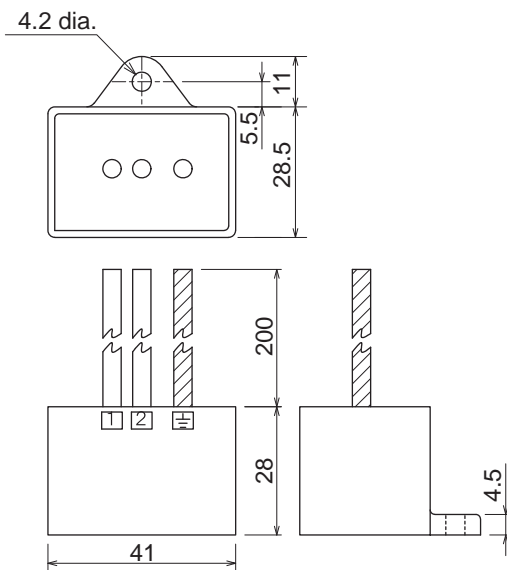

Three-phase BXZ Series

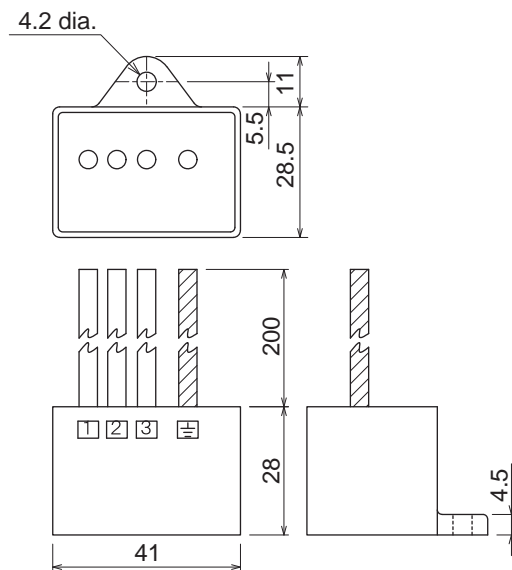

### Equalizing Circuits

Single-phase BWZ Series

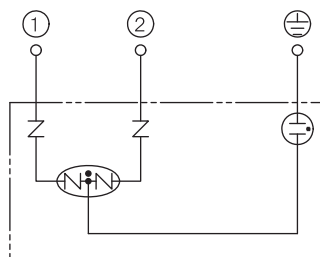

Three-phase BXZ Series

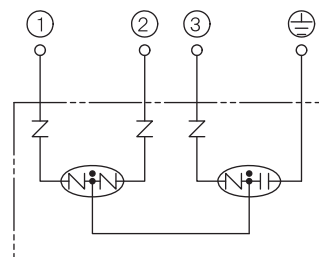



■ Noise Filter for the Power Supply Input

Use the following noise filter for the Servo Drive's power supply.

Servo Drive model	Noise filter				
	Model	Rated current	Rated voltage	Max. leakage current (60 Hz)	Maker
R7D-BP Series	3SUP-HU10-ER-6	10 A	250 VAC	0.4 mA/phase	Okaya Electric Industries Co., Ltd.

Dimensions

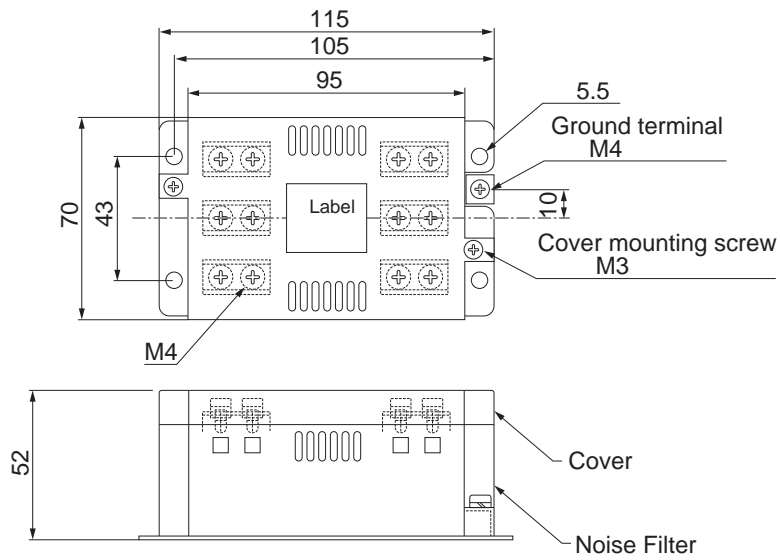

## 4-3 Wiring Conforming to EMC Directives

### ■ Radio Noise Filters and Emission Noise Prevention Clamp Cores

Use one of the following filters to prevent switching noise of PWM of the Servo Drive and to prevent noise emitted from the internal oscillation circuit.

Model	Maker	Application
3G3AX-ZCL2 <sup>*1</sup>	OMRON	Servo Drive output and power cable
ESD-R-47B <sup>*2</sup>	NEC TOKIN	Servo Drive output and power cable
ZCAT3035-1330 <sup>*3</sup>	TDK	Encoder cable and I/O cable

\*1. Mainly used for 200/400 W. The maximum number of windings is three turns.

\*2. Mainly used for 50/100 W. The maximum number of windings is two turns.

\*3. Also used on the Servo Drive output power lines to comply with the EMC Directives. Only a clamp is used. This clamp can also be used to reduce noise current on a frame ground line.

#### Dimensions

3G3AX-ZCL2

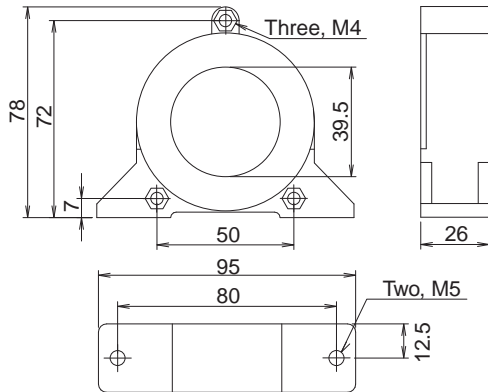

ESD-R-47B

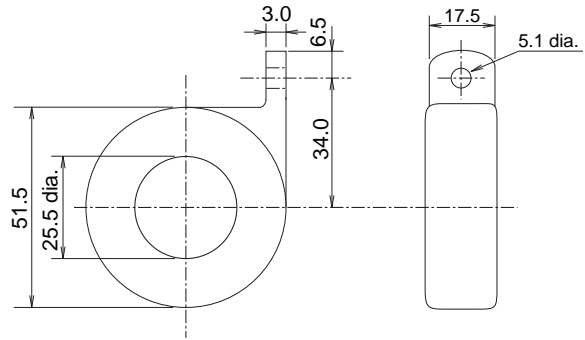

ZCAT 3035-1330

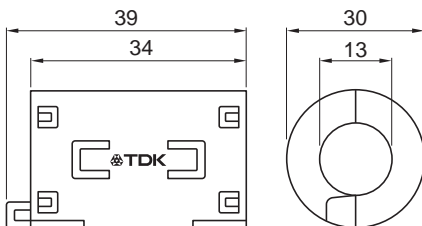

Impedance Characteristics

3G3AX-ZCL2

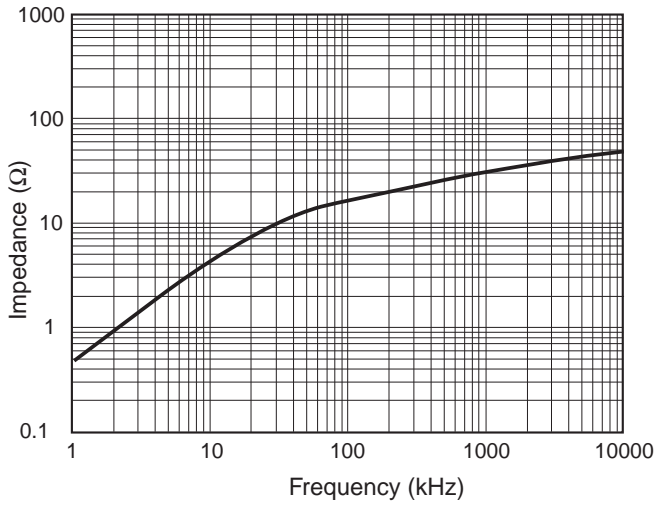

ESD-R-47B

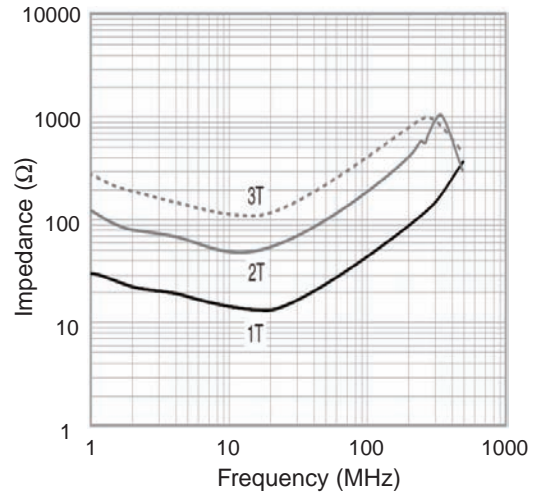

ZCAT 3035-1330

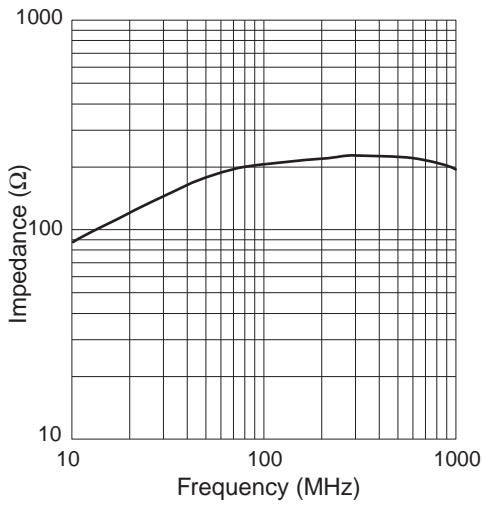

### ■ Surge Suppressors

- ♦ Install surge suppressors for loads that have induction coils, such as relays, solenoids, brakes, clutches, etc.
- ♦ The following table shows the types of surge suppressors and recommended products.

Type	Features	Recommended products
Diode	Diodes are used for relatively small loads when the reset time is not an issue, such as relays. At power shutoff, the surge voltage is the lowest, but the reset time becomes longer. Used for 24/48-VDC systems.	Use a fast-recovery diode with a short reverse recovery time (e.g., RU2 of Sanken Electric Co., Ltd.).
Thyristor or varistor	Thyristors and varistors are used for loads when induction coils are large, as in electromagnetic brakes, solenoids, etc., and when reset time is an issue. The surge voltage at power shutoff is approximately 1.5 times the varistor voltage.	Select the varistor voltage as follows: 24 VDC system: Varistor V0 39 V 100 VDC system: Varistor V0 200 V 100 VAC system: Varistor V0 270 V 200 VAC system: Varistor V0 470 V
Capacitor + resistor	The capacitor and resistor dissipate and absorb the surge at power shutoff. The reset time can be shortened by selecting the appropriate capacitor and resistance values.	Okaya Electric Industries Co., Ltd. XEB12002 0.2 $\mu$ F - 120 $\Omega$ XEB12003 0.3 $\mu$ F - 120 $\Omega$

**Note** Thyristors and varistors are made by the following companies. Refer to manufacturers' documentation for details on these components.

Thyristors: Ishizuka Electronics Co.

Varistors: Ishizuka Electronics Co., Matsushita Electric Industrial Co.

### ■ Contactors

- ♦ Select contactors based on the circuit's inrush current and the maximum momentary phase current.
- ♦ The Servo Drive inrush current is covered in the preceding explanation of no-fuse breaker selection, and the maximum momentary phase current is approximately twice of the rated current.
- ♦ The following table shows the recommended contactors.

Maker	Model	Rated current	Coil voltage
OMRON	J7L-09-22200	11 A	200 VAC
	J7L-12-22200	13 A	200 VAC
	J7L-18-22200	18 A	200 VAC
	J7L-32-22200	26 A	200 VAC

■ Improving Encoder Cable Noise Resistance

Take the following steps during wiring and installation to improve the encoder's noise resistance.

- ◆ Always use the specified Encoder Cables.
- ◆ If cables are joined midway, be sure to use connectors and do not remove more than 50 mm of the cable insulation. In addition, always use shielded cables.
- ◆ Do not coil cables. If cables are long and coiled, mutual induction and inductance will increase and cause malfunctions. Always use cables fully extended.
- ◆ When installing noise filters for Encoder Cables, use clamp filters.
- ◆ The following table shows the recommended clamp filters.

Maker	Product name	Model	Specifications
NEC TOKIN	Clamp filter	ESD-SR-250	For cable diameter up to 13 mm
TDK	Clamp filter	ZCAT3035-1330	For cable diameter up to 13 mm

- ◆ Do not place the Encoder Cable with the following cables in the same duct.  
Control Cables for brakes, solenoids, clutches, and valves.

Dimensions

ESD-SR-250

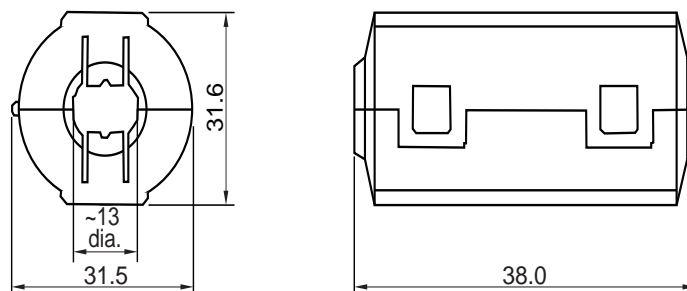

Impedance Characteristics

ESD-SR-250

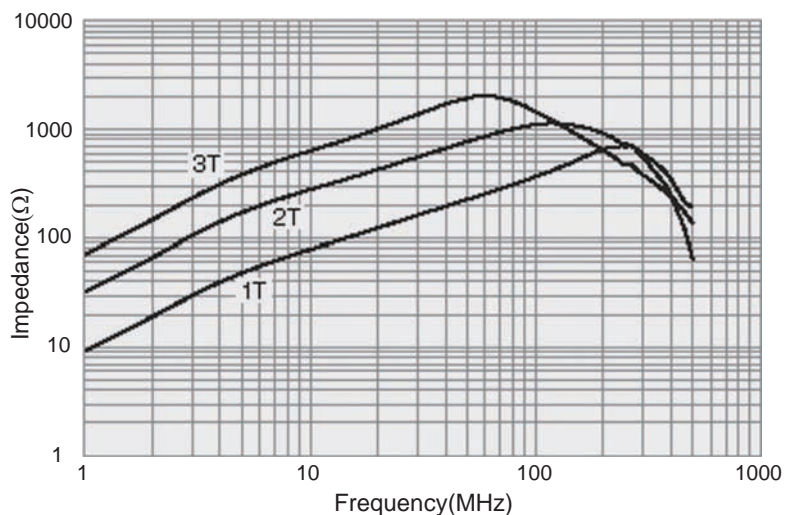

For information on the TDK clamp filter (ZCAT3035-1330), refer to *Radio Noise Filters and Emission Noise Prevention Clamp Cores* on page 4-25.

### ■ Improving Control I/O Signal Noise Resistance

Positioning can be affected and I/O signal errors can occur if control I/O is influenced by noise.

- ♦ Use completely separate power supplies for the control power supply (especially 24 VDC) and for the external operation power supply. In particular, do not connect the two power supply ground wires.
- ♦ Install a noise filter on the primary side of the control power supply.
- ♦ If Servomotors with brakes are used, do not use the same 24-VDC power supply for both the brakes and the control I/O. Additionally, do not connect the ground wires. Connecting the ground wires may cause I/O signal errors.
- ♦ Keep the power supply for pulse commands and deviation counter reset input lines separated from the control power supply as far apart as possible. In particular, do not connect the two power supply ground lines.
- ♦ We recommend using line drivers for the pulse command output.
- ♦ Always use twisted-pair shielded cable for the pulse command and deviation counter reset signal lines, and connect both ends of the shield to frame grounds.
- ♦ If the control power supply wiring is long, noise resistance can be improved by adding 1- $\mu$ F laminated ceramic capacitors between the control power supply and ground at the Servo Drive input section or the controller output section.
- ♦ For open-collector specifications, keep the length of wires to within two meters.

### ■ Selecting Other Parts for Noise Resistance

This section explains the criteria for selecting other connection components required to improve noise resistance.

Understand each component's characteristics, such as its capacity, performance, and applicable conditions when selecting the components.

For more details, contact the manufacturers directly.

### Noise Filters for the Power Supply Input

- ♦ Use a noise filter to attenuate external noise and reduce noise emitted from the Servo Drive.
- ♦ Select a noise filter with a rated current that is at least two times greater than the effective load current (the rated current of the main circuit power supply input given in *Main Circuit Wiring* on page 4-15).

Maker	Model	Rated current	Applicable standards	Remarks
NEC TOKIN	GT-2050	5 A	UL, CSA, VDE, TUV	Single-phase
	GT-2100	10 A		
	GT-2150	15 A		
	GT-2200	20 A		
	HFP-2153	15 A	UL, CSA, TUV	Three-phase
	HFP-2303	30 A		
Okaya Electric Industries Co., Ltd.	SUP-EW5-ER-6	5 A	UL, cUL, SEMKO	Single-phase
	SUP-EW10-ER-6	10 A		
	SUP-EW15-ER-6	15 A		
	SUP-EW20-ER-6	20 A		
	SUP-EW30-ER-6	30 A		Three-phase
	3SUP-HU10-ER-6	10 A		
	3SUP-HU20-ER-6	20 A		
TDK	ZRCS2006-00S	6 A	UL, CSA, NEMKO	Single-phase
	ZRCS2010-00S	10 A		
	ZRCS2020-00S	20 A		
	ZRCS2030-00S	30 A		

**Note 1.** To attenuate noise at low frequencies below 200 kHz, use an isolation transformer and a noise filter.

**Note 2.** To attenuate noise at high frequencies over 30 MHz, use a ferrite core and a high-frequency noise filter with a feed through capacitor.

**Note 3.** If multiple Servo Drives are connected to a single noise filter, select a noise filter with a rated current at least two times the total rated current of all the Servo Drives.

### Noise Filters for Servomotor Output

- ♦ Use noise filters without built-in capacitors on the Servomotor output lines.
- ♦ Select a noise filter with a rated current at least two times the Servo Drive's continuous output current.
- ♦ The following table shows the recommended noise filters for Servomotor output.

Maker	Model	Rated current	Remarks
OMRON	3G3AX-NF001	6 A	For inverter output
	3G3AX-NF002	12 A	

**Note 1.** Servomotor output lines cannot use the same noise filters for power supplies.

**Note 2.** Typical noise filters are made for power supply frequencies of 50/60 Hz. If these noise filters are connected to the PWM output of the Servo Drive, an extremely large (about 100 times larger) leakage current will flow through the noise filter's condenser and the Servo Drive could be damaged.

Dimensions

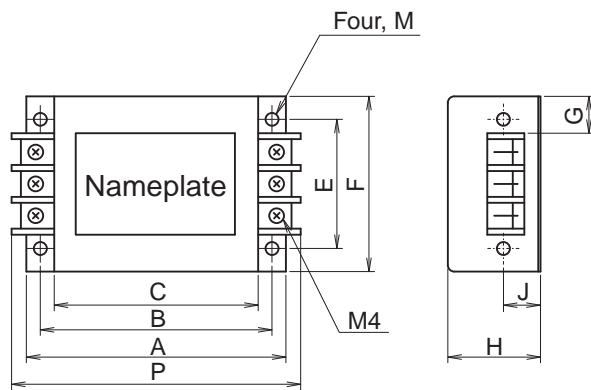

Model	Dimensions (mm)									
	A	B	C	E	F	G	H	J	M	P
3G3AX-NF001	140	125	110	70	95	22	50	20	4.5	156
3G3AX-NF002	160	145	130	80	110	30	70	25	5.5	176

Measures against Brake Line Noise

- ♦ To reduce the noise from the brake line of the Servomotor, use a clamp filter of the same type used for the Encoder Cable.



## 4-4 Regenerative Energy Absorption

The Servo Drives have internal regenerative energy absorption circuitry, which absorbs the regenerative energy produced during Servomotor deceleration and prevents the DC voltage from increasing. An overvoltage error occurs, however, if the amount of regenerative energy from the Servomotor is too large. In this case, measures must be taken to reduce the regenerative energy by changing operating patterns, or to increase the regenerative energy absorption capacity by connecting an External Regeneration Resistor.

### Calculating the Regenerative Energy

#### ■ Horizontal Axis

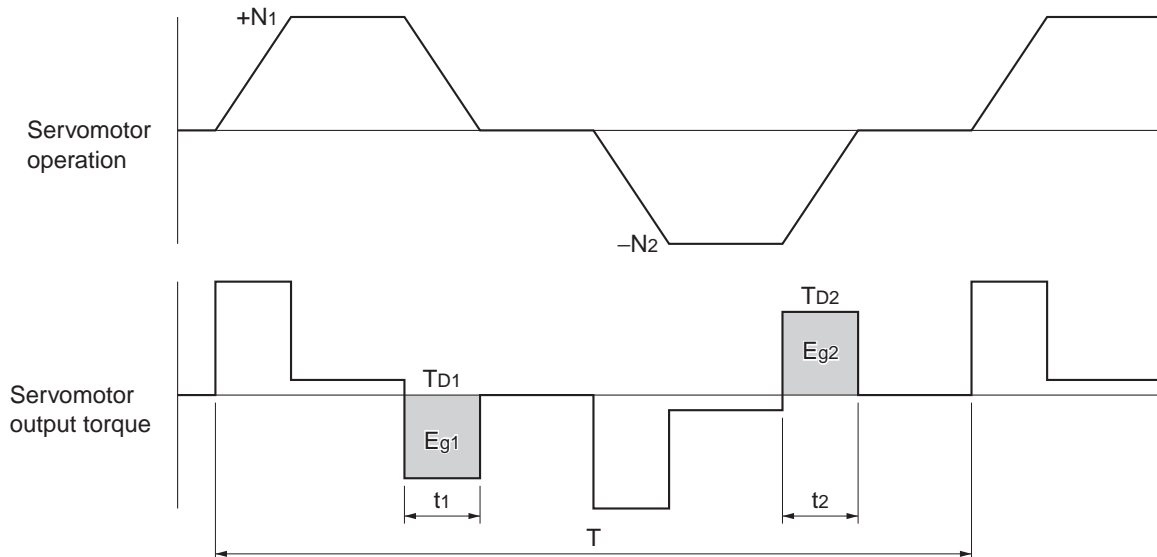

**Note** In the output torque graph, acceleration in the positive direction is shown as positive, and acceleration in the negative direction is shown as negative.

♦ The regenerative energy values for each region can be derived from the following equations.

$$E_{g1} = \frac{1}{2} * \frac{2\pi}{60} * N_1 * T_{D1} * t_1 \text{ [J]} = 0.0524 * N_1 * T_{D1} * t_1 \text{ [J]}$$

$$E_{g2} = \frac{1}{2} * \frac{2\pi}{60} * N_2 * T_{D2} * t_2 \text{ [J]} = 0.0524 * N_2 * T_{D2} * t_2 \text{ [J]}$$

$N_1, N_2$ : Rotation speed at beginning of deceleration [r/min]

$T_{D1}, T_{D2}$ : Deceleration torque [N·m]

$t_1, t_2$ : Deceleration time [s]

**Note** Due to the loss of winding resistance and PWM, the actual regenerative energy will be approximately 90% of the values derived from these equations.

♦ Average regeneration power ( $P_r$ ): Regeneration power produced in one cycle of operation.

$$P_r = (E_{g1} + E_{g2}) / T \text{ [W]} \quad T: \text{ Operation cycle [s]}$$

## 4-4 Regenerative Energy Absorption

- ◆ Since an internal capacitor absorbs regenerative energy, the value for  $E_{g1}$  and  $E_{g2}$  (unit: J) must be lower than the Servo Drive's regenerative energy absorption capacity. (For details, refer to *Servo Drive Regenerative Energy Absorption Capacity* on page 4-34.) If an External Regeneration Resistor is connected, be sure that the average regeneration power ( $P_r$ ) does not exceed the External Regeneration Resistor's regenerative energy absorption capacity (12 W).

### ■ Vertical Axis

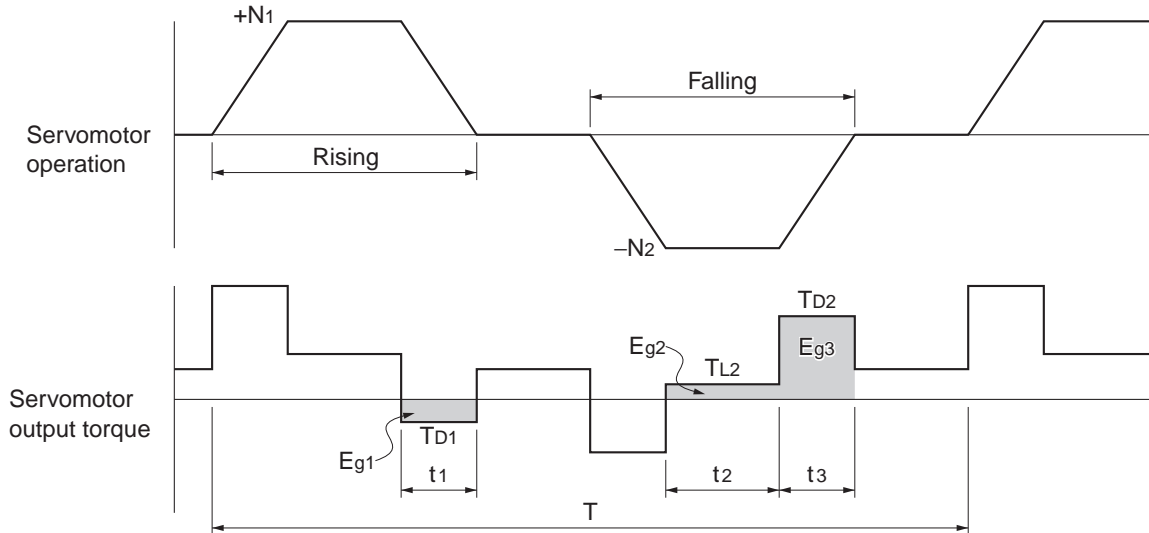

**Note** In the output torque graph, acceleration in the positive direction (rising) is shown as positive, and acceleration in the negative direction (falling) is shown as negative.

- ◆ The regenerative energy values in each region can be derived from the following equations.

$$E_{g1} = \frac{1}{2} * \frac{2\pi}{60} * N_1 * T_{D1} * t_1 \quad [\text{J}] = 0.0524 * N_1 * T_{D1} * t_1 \quad [\text{J}]$$

$$E_{g2} = \frac{2\pi}{60} * N_2 * T_{L2} * t_2 \quad [\text{J}] = 0.105 * N_2 * T_{D2} * t_3 \quad [\text{J}]$$

$$E_{g3} = \frac{1}{2} * \frac{2\pi}{60} * N_2 * T_{D2} * t_3 \quad [\text{J}] = 0.0524 * N_2 * T_{D2} * t_3 \quad [\text{J}]$$

$N_1, N_2$ : Rotation speed at beginning of deceleration [r/min]

$T_{D1}, T_{D2}$ : Deceleration torque [N·m]

$T_{L2}$ : Torque when falling [N·m]

$t_1, t_3$ : Deceleration time [s]

$t_2$ : Constant-velocity running time when falling [s]

**Note** Due to the loss of winding resistance and PWM, the actual regenerative energy will be approximately 90% of the values derived from these equations.

- ◆ The average regeneration power ( $P_r$ ): Regeneration power produced in one cycle of operation [W].

$$P_r = (E_{g1} + E_{g2} + E_{g3}) / T \quad [\text{W}] \quad T: \text{Operation cycle [s]}$$

- ◆ Since an internal capacitor absorbs regenerative energy, the value for  $E_{g1}$  and  $(E_{g2} + E_{g3})$  (unit: J) must be lower than the Servo Drive's regenerative energy absorption capacity. (For details, refer to *Servo Drive Regenerative Energy Absorption Capacity*.)

## Servo Drive Regenerative Energy Absorption Capacity

The SMARTSTEP 2 Servo Drives absorb regenerative energy internally with built-in capacitors. If the regenerative energy is too large to be processed internally, an overvoltage error (AL12) occurs and operation cannot continue. The following table shows the regenerative energy (and amount of regeneration) that each Servo Drive can absorb.

If these values are exceeded, take the following measures.

- ♦ Add an External Regeneration Resistor.
- ♦ Reduce the operating rotation speed. (The amount of regeneration is proportional to the square of the rotation speed.)
- ♦ Lengthen the deceleration time (to decrease the regenerative energy produced per time unit).
- ♦ Lengthen the operation cycle, i.e., the cycle time (to decrease the average regeneration power).

Servo Drive	Regenerative energy that can be absorbed by the internal capacitor	Minimum external regenerative resistance
	J	$\Omega$
R7D-BPA5L R7D-BP01L	6	20
R7D-BP02L	12	20
R7D-BP01H	8	50
R7D-BP02H R7D-BP02HH	16	35
R7D-BP04H	16	35

## Absorbing Regenerative Energy with an External Regeneration Resistor

If the regenerative energy exceeds the absorption capacity of the Servo Drive, connect an External Regeneration Resistor. Connect the External Regeneration Resistor to CNA pins 5 and 3 (between terminals P and B1) of the Servo Drive. Double-check the pin numbers when connecting the resistor because the Regeneration Resistor may be damaged by burning if connected to the wrong terminals. The External Regeneration Resistor will heat up to approximately 120°C. Do not place it near equipment or wiring that is easily affected by heat. Attach radiator plates suitable for the heat radiation conditions.

### ■ External Regeneration Resistor

#### Performance Specifications

Model	Resistance	Nominal capacity	Regeneration absorption at 120°C	Heat radiation condition	Thermal switch output specifications
R88A-RR08050S	50 $\Omega$	80 W	20 W	Aluminum 250 × 250, Thickness: 3.0	Operating temperature: 150°C ±5% NC contact Rated output: 30 VDC, 50 mA max.
R88A-RR080100S	100 $\Omega$	80 W	20 W	Aluminum 250 × 250, Thickness: 3.0	Operating temperature: 150°C ±5% NC contact Rated output: 30 VDC, 50 mA max.
R88A-RR22047S	47 $\Omega$	220 W	70 W	Aluminum 350 × 350, Thickness: 3.0	Operating temperature: 170°C ±5% NC contact Rated output: 250 VAC, 0.2 A max.

## 4-4 Regenerative Energy Absorption

### Wiring Method

Connect the External Regeneration Resistor between terminals P and B1.

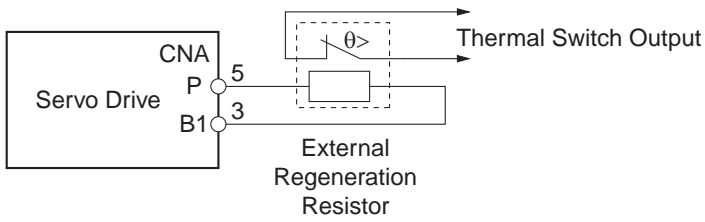

#### Precautions for Correct Use

◆ Connect the thermal switch output so that the power supply is shut OFF when the contacts open. Configure a sequence to shut OFF the power via the thermal output. Not doing so may cause the resistor to overheat, resulting in a fire or damage to the equipment.

### Combining External Regeneration Resistors

Regeneration absorption capacity <sup>*1</sup>	20 W	40 W	70 W	140 W
Model	R88A-RR08050S R88A-RR080100S	R88A-RR08050S R88A-RR080100S	R88A-RR22047S	R88A-RR22047S
Resistance <sup>*2</sup>	50 Ω/100 Ω	25 Ω/50 Ω	47 Ω	94 Ω
Connection method				

\*1. Select a combination that has an absorption capacity greater than the average regeneration power ( $P_r$ ).

\*2. Do not use a combination of resistors with a resistance lower than the minimum external regenerative resistance of each Servo Drive. For information on the minimum external regenerative resistance, refer to *Servo Drive Regenerative Energy Absorption Capacity* on page 4-34.

# Chapter 5

## Operating Functions

<b>5-1</b>	<b>Position Control .....</b>	<b>5-1</b>
	High-Response Position Control vs. Advanced Position Control .....	5-1
	Parameters Requiring Settings .....	5-1
	Related Parameters .....	5-2
	Parameter Block Diagram for Position Control Mode .....	5-3
<b>5-2</b>	<b>Internally Set Speed Control .....</b>	<b>5-4</b>
	Parameters Requiring Settings .....	5-4
	Related Parameters .....	5-4
	Selecting the Internally Set Speeds .....	5-5
	Operation .....	5-5
	Parameter Block Diagram for Internally Set Speed Control Mode .....	5-6
<b>5-3</b>	<b>Forward and Reverse Drive Prohibit .....</b>	<b>5-7</b>
	Parameters Requiring Settings .....	5-7
	Operation .....	5-7
<b>5-4</b>	<b>Encoder Dividing.....</b>	<b>5-8</b>
	Parameters Requiring Setting.....	5-8
	Operation .....	5-8
<b>5-5</b>	<b>Electronic Gear.....</b>	<b>5-9</b>
	Parameters Requiring Settings .....	5-9
	Operation .....	5-9
	Related Parameter.....	5-10
<b>5-6</b>	<b>Brake Interlock .....</b>	<b>5-11</b>
	Parameters Requiring Setting.....	5-11
	Operation .....	5-11
<b>5-7</b>	<b>Gain Switching .....</b>	<b>5-13</b>
	Parameters Requiring Setting.....	5-13
	Related Parameters .....	5-14
<b>5-8</b>	<b>Torque Limit .....</b>	<b>5-15</b>
	Parameters Requiring Setting.....	5-15
	Related Parameters .....	5-15
<b>5-9</b>	<b>Overrun Limit.....</b>	<b>5-16</b>
	Parameters Requiring Settings .....	5-16
	Operation .....	5-16
<b>5-10</b>	<b>User Parameters.....</b>	<b>5-17</b>
	Setting and Checking Parameters .....	5-17
	Parameter List.....	5-20
	Parameter Details .....	5-32

## 5-1 Position Control

- ♦ Positioning can be performed according to the pulses input into the pulse-string inputs (CN1-22 to 25).
- ♦ The Servomotor rotates using the value of the pulse-string inputs multiplied by the value of the electronic gear (Pn46, Pn47, Pn4A, and Pn4B).
- ♦ SMARTSTEP2 Series Servo Drives have two position control modes: high-response position control and advanced position control. Select the mode better suited for your operational conditions.

### High-Response Position Control vs. Advanced Position Control

The two position control modes have the following differences.

	Notch Filter 1 Frequency (Pn1D)	Vibration Frequency (Pn2B)	Realtime Autotuning Mode Selection (Pn21)	Adaptive Filter Table Number Display (Pn2F)
High-Response Position Control	Conditional	Conditional	Conditional	Disabled
Advanced Position Control	Enabled	Enabled	Enabled	Enabled

- ♦ The Notch Filter 1 Frequency, Vibration Frequency, and Realtime Autotuning Mode Selection cannot be used at the same time in high-response position control mode. The parameter entered first will be given priority.

Example: When the Realtime Autotuning Mode Selection is set, the Servo Drive will be forcibly set to 1500 (disabled), even if the Notch Filter 1 Frequency is input.

- ♦ The adaptive filter will be disabled under high-response position control. To use the adaptive filter, select the advanced position control mode.

### Parameters Requiring Settings

Parameter No.	Parameter name	Explanation	Reference
Pn02	Control Mode Selection	Select a control mode for position control (setting: 0 or 2).	Page 5-33
Pn42	Command Pulse Mode	Set to match the command pulse form of the controller.	Page 5-49
Pn46	Electronic Gear Ratio Numerator 1	Set the pulse rate for command pulses and Servomotor travel amount.	Page 5-50
Pn4A	Electronic Gear Ratio Numerator Exponent	$\frac{\text{Electronic Gear Ratio Numerator 1 (Pn46)} \times 2^{\text{Electronic Gear Ratio Numerator Exponent (Pn4A)}}}{\text{Electronic Gear Ratio Denominator (Pn4B)}}$	
Pn4B	Electronic Gear Ratio Denominator	The maximum value of the calculated numerator is 2,621,440.	
Pn60	Positioning Completion Range	The Positioning Completed Output (INP) turns ON when the number of pulses in the deviation counter is equal to or less than the setting of this parameter.	Page 5-55

**Reference** ♦ The Control Mode Selection (Pn02) is set as follows.

Setting	Control mode
0	High-Response Position Control
1	Internally Set Speed Control
2	Advanced Position Control

♦ To perform position control, select 0 (high-response position control) or 2 (advanced position control) for the control mode.

## Related Parameters

The main functions provided by the parameters related to position control are described in the following table.

Function	Explanation	Reference
Gain Switching	The Gain Switching Input (GSEL) is used when the Zero Speed Designation/Torque Limit Switch (Pn06) is set to a value other than 2. The Gain Switching Input is used to switch between PI and P operation or to switch between gain 1 and gain 2.	Page 5-13
Torque Limit Switch	The Torque Limit Switch Input (TLSEL) is used when the Zero Speed Designation/Torque Limit Switch (Pn06) is set to 2. The following parameters are switched: Overspeed Detection Level, Torque Limit, and Deviation Counter Overflow Level.	Page 5-15
Damping Control	Damping control can be used to reduce vibration when using a low-rigidity mechanism or equipment whose ends tend to vibrate.	Page 7-23
Realtime Autotuning	Autotuning automatically estimates the load inertia of the machine in realtime and sets the optimal gain. The adaptive filter automatically suppresses vibration caused by resonance.	Page 7-3

Parameter Block Diagram for Position Control Mode

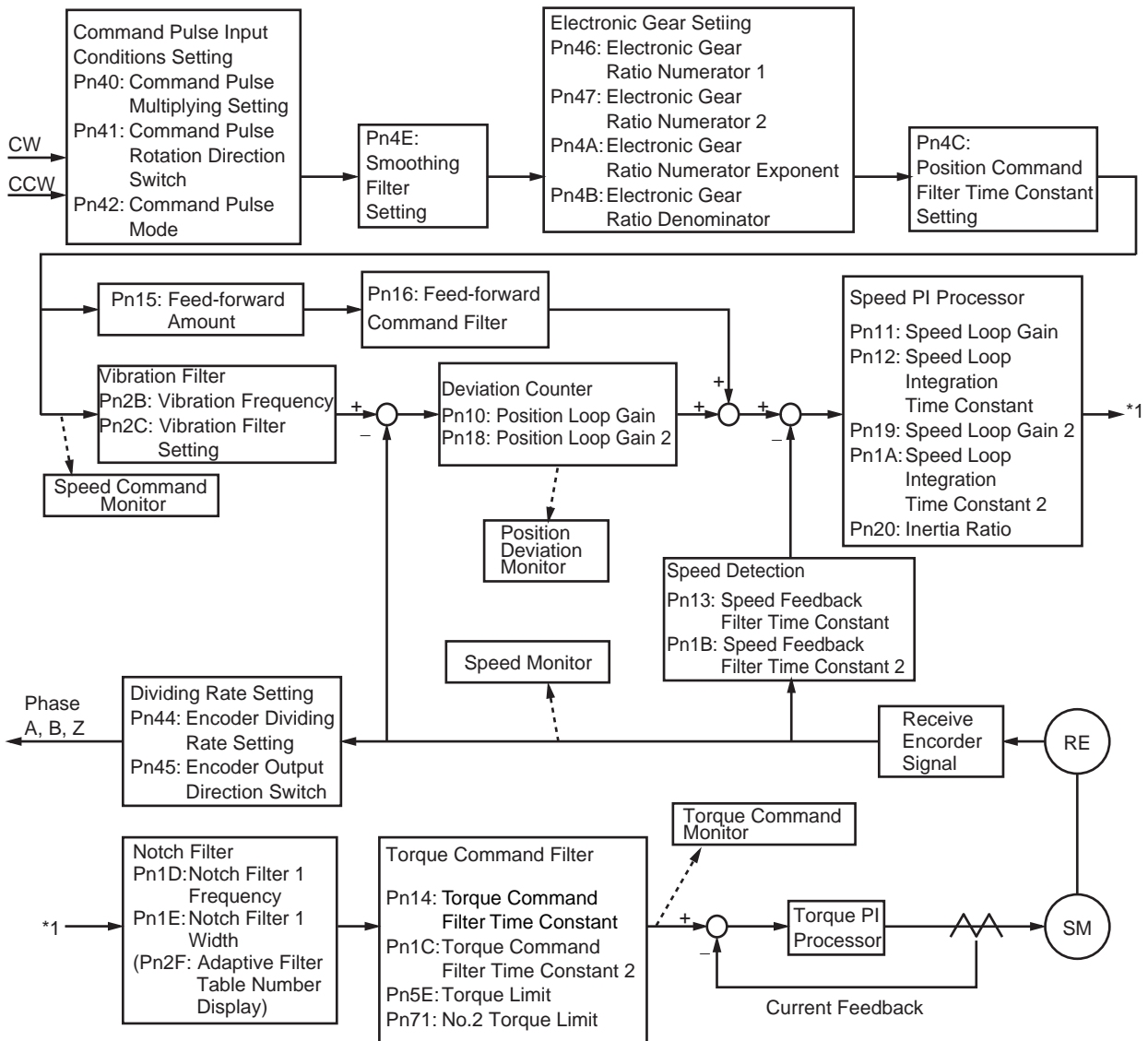

5

Operating Functions



## 5-2 Internally Set Speed Control

- ♦ The speed of the Servomotor can be controlled using the speeds set in the No. 1 to 4 Internal Speed Setting parameters.
- ♦ After the RUN Command Input (RUN) is turned ON and then the Zero Speed Designation Input (VZERO) is turned ON, the Servomotor will accelerate according to the Soft Start Acceleration Time (Pn58). When the Zero Speed Designation Input (VZERO) is turned OFF, the Servomotor will decelerate to a stop according to the Soft Start Deceleration Time (Pn59).
- ♦ Switching between the internally set speeds is controlled by the Internally Set Speed Selection 1 and 2 Inputs (VSEL1: CN1-6, VSEL2: CN1-4).

### Parameters Requiring Settings

Parameter No.	Parameter name	Explanation	Reference
Pn02	Control Mode Selection	Select the control mode for internally set speeds (setting: 1).	Page 5-33
Pn06	Zero-speed Designation/ Torque Limit Switch	Always enable the zero-speed designation when internally set speeds are used (setting: 1).	Page 5-34
Pn53	No. 1 Internal Speed Setting	Set the internally set speeds (r/min). The settings can be made from -20,000 to 20,000 r/min. Be sure to set the speeds within the allowable range of rotation speed of the Servomotor.	Page 5-53
Pn54	No. 2 Internal Speed Setting		
Pn55	No. 3 Internal Speed Setting		
Pn56	No. 4 Internal Speed Setting		
Pn58	Soft Start Acceleration Time	Set the acceleration time for Internally Set Speed Control. Set the time (setting × 2 ms) until 1,000 r/min is reached.	Page 5-53
Pn59	Soft Start Deceleration Time	Set the deceleration time for Internally Set Speed Control. Set the time (setting × 2 ms) until operation stops from 1,000 r/min.	

### Related Parameters

The main functions provided by the parameters related to Internally Set Speed Control are described in the following table.

Function	Explanation	Reference
Torque Limit Switch	The Torque Limit Switch Input (TLSEL) is used when the Zero Speed Designation/Torque Limit Switch (Pn06) is set to 2. The following parameters are switched: Overspeed Detection Level, Torque Limit, and Deviation Counter Overflow Level.	Page 5-15
Zero Speed Detection	The Zero Speed Detection Signal will be output if the speed of the Servomotor falls below the setting of this parameter. The Warning Output Selection (Pn09) must be set to 1 to use this function.	Page 5-55
Motor Rotation Detection	The Servomotor Rotation Speed Detection Output (TGON) will be output if the speed of the Servomotor exceeds the setting of this parameter.	Page 5-56

## 5-2 Internally Set Speed Control

### Selecting the Internally Set Speeds

The four internally set speeds are switched by using the Internally Set Speed Selection 1 Input (VSEL1) and Internally Set Speed Selection 2 Input (VSEL2).

Internally set speed	Internally Set Speed Selection 1 Input (VSEL1) (CN1-6)	Internally Set Speed Selection 2 Input (VSEL2) (CN1-4)
No. 1 Internally Set Speed (Pn53)	OFF	OFF
No. 2 Internally Set Speed (Pn54)	ON	OFF
No. 3 Internally Set Speed (Pn55)	OFF	ON
No. 4 Internally Set Speed (Pn56)	ON	ON

### Operation

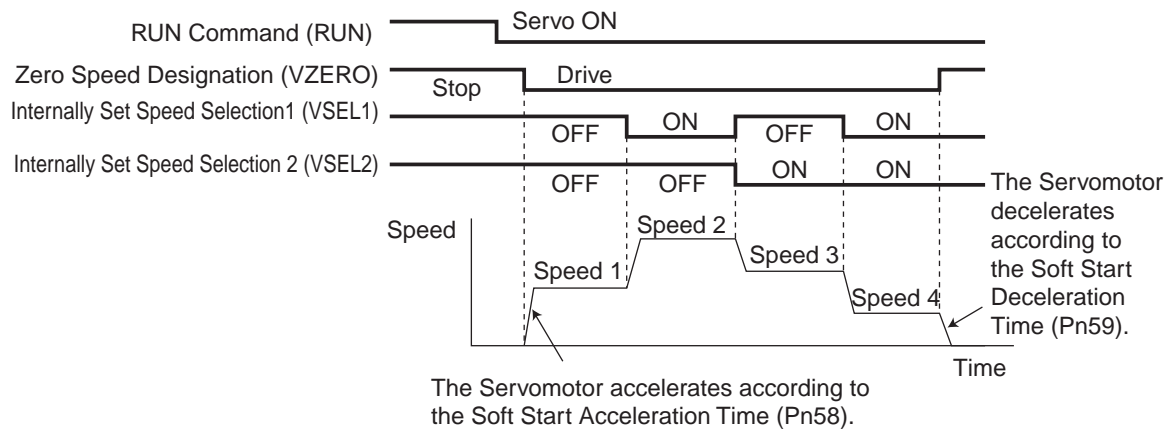

Parameter Block Diagram for Internally Set Speed Control Mode

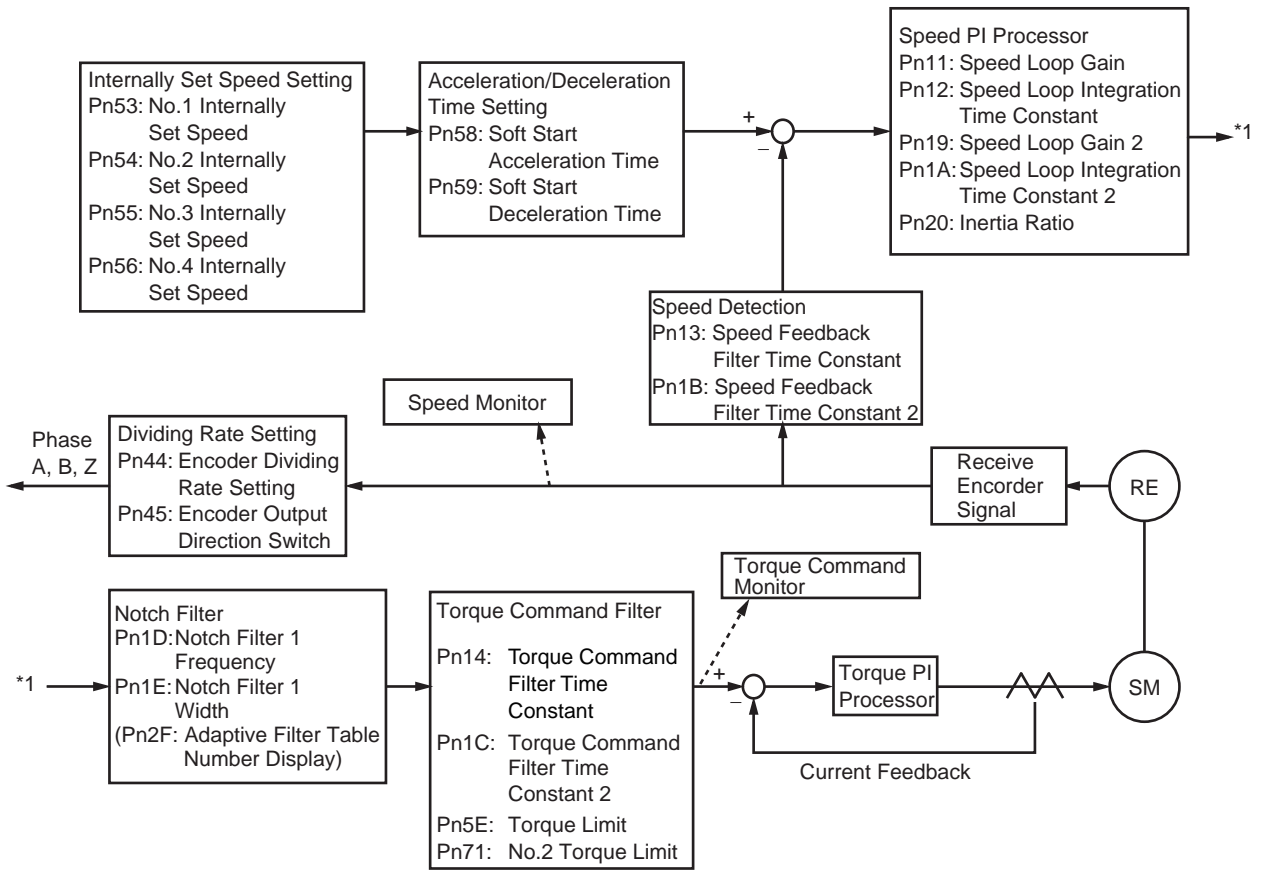

## 5-3 Forward and Reverse Drive Prohibit

- ◆ When the Forward Drive Prohibit Input (POT: CN1-8) and Reverse Drive Prohibit Input (NOT: CN1-7) are turned OFF, the Servomotor will stop rotating.
- ◆ You can prevent the Servomotor from rotating beyond the device's travel range by connecting limit inputs.

### Parameters Requiring Settings

Parameter No.	Parameter name	Explanation	Reference
Pn04	Drive Prohibit Input Selection	Enable or disable the Forward/Reverse Drive Prohibit Inputs.	Page 5-33
Pn66	Stop Selection for Drive Prohibit Input	Set the operation for decelerating to a stop after the Forward/Reverse Drive Prohibit Input turns OFF. This parameter can be used to set whether to stop with the dynamic brake or free-running.	Page 5-57

### Operation

Stopping Methods When Forward/Reverse Drive Prohibit Is OFF.

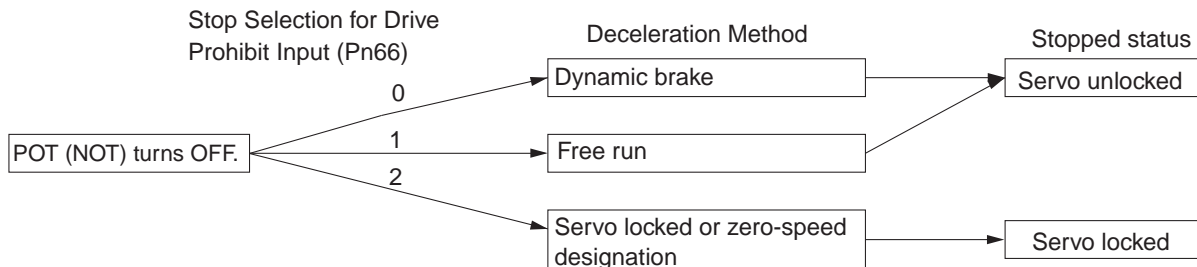

While the Forward Drive Prohibit Input (POT) is OFF, the Servomotor cannot be driven in the forward direction, but it can be driven in the reverse direction. Conversely, while the Reverse Drive Prohibit Input (NOT) is OFF, the Servomotor cannot be driven in the reverse direction, but it can be driven in the forward direction.

## 5-4 Encoder Dividing

- ◆ The number of pulses can be set for the encoder signals output from the Servo Drive.
- ◆ The number of pulses per Servomotor rotation can be set within a range of 1 to 2,500 pulses/rotation.
- ◆ Use this function for the following applications:
  - ◆ When using a controller with a low response frequency.
  - ◆ When it is desirable to set a pulse rate that is easily divisible.

Example:

To use a resolution of 5  $\mu\text{m}/\text{pulse}$  in a mechanical system in which one Servomotor rotation corresponds to a travel of 10 mm, set the encoder dividing rate to 2,000 pulses/rotation.

### Parameters Requiring Setting

Parameter No.	Parameter name	Explanation	Reference
Pn44	Encoder Dividing Rate Setting	Set the number of encoder pulses to be output from the Servo Drive for each rotation. The default setting is 2,500 pulses/rotation. The setting can be made from 1 to 16,384 pulses/rotation, but the setting will not be valid if it exceeds 2,500 pulses/rotation. Even if the dividing rate is changed, there will always be 1 pulse per rotation for phase Z.	Page 5-49
Pn45	Encoder Output Direction Switch	This parameter can be used to reverse the output phase of the encoder signal output from the Servo Drive.	Page 5-50

### Operation

The output phases of the encoder signal output from the Servo Drive are as shown below.

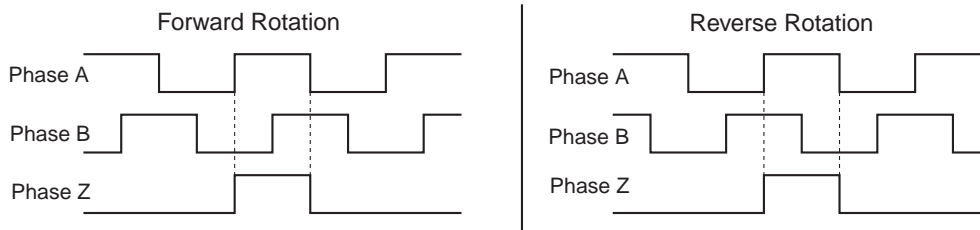

## 5-5 Electronic Gear

- ♦ The Servomotor can be rotated for the number of pulses obtained by multiplying the command pulses by the electronic gear ratio.
- ♦ This function is effective in the following cases:
  - When fine-tuning the position and speed of two lines that are to be synchronous.
  - When using a position controller with a low command pulse frequency.
  - When you want to set the machine travel distance per pulse, to 0.01 mm for example.

### Parameters Requiring Settings

Parameter No.	Parameter name	Explanation	Reference
Pn46	Electronic Gear Ratio Numerator 1 *1	Set the pulse rate for command pulses and Servomotor travel distance.  $\frac{\text{Electronic Gear Ratio Numerator 1 (Pn46)} \quad \text{or} \quad \text{Electronic Gear Ratio Numerator Exponent (Pn4A)} \times 2}{\text{Electronic Gear Ratio Numerator 2 (Pn47)}} \times \text{Electronic Gear Ratio Denominator (Pn4B)}$ The maximum value of the calculated numerator is 2,621,440. Any higher setting than this will be invalid, and the numerator will be 2,621,440.	Page 5-50
Pn47	Electronic Gear Ratio Numerator 2 *1		
Pn4A	Electronic Gear Ratio Numerator Exponent		
Pn4B	Electronic Gear Ratio Denominator		Page 5-51

\*1. The Electronic Gear Switch Input (GESEL) is used to switch between Electronic Gear Ratio Numerator 1 (Pn46) and Electronic Gear Ratio Numerator 2 (Pn47).

## Operation

### Calculation Method

- ♦ The following equation shows the relation between the number of internal command pulses (F) after the electronic gear ratio multiplication and the number of command pulses (f) per Servomotor rotation.

$$F = f \times \frac{\text{Pn46} \times 2^{\text{Pn4A}}}{\text{Pn4B}}$$

- ♦ The Servomotor has a 2,500 pulses/rotation encoder. Therefore, the number of internal command pulses (F) in the Servo Drive is 10,000 pulses/rotation (2,500 pulses/rotation × 4).
- ♦ Given the conditions above, the relation between the number of command pulses per Servomotor rotation (f) and the electronic gear ratio is as follows:

$$\frac{F}{f} = \frac{10000}{f} = \frac{\text{Pn46} \times 2^{\text{Pn4A}}}{\text{Pn4B}} \left( = \frac{\text{Encoder resolution (by a factor of 4)}}{\text{Number of command pulses for Servomotor rotation}} \right)$$

### Calculation Examples

- ♦ To operate with 2,000 pulses/rotation:

$$\frac{10000 (\text{Pn46}) \times 2^0 (\text{Pn4A})}{2000 (\text{Pn48})}$$

- ♦ To operate with 1,000 pulses/rotation:

$$\frac{10000 (\text{Pn46}) \times 2^0 (\text{Pn4A})}{1000 (\text{Pn48})}$$

- ♦ Conversely, to increase the resolution per rotation and operate with 40,000 pulses/rotation:

$$\frac{10000 (\text{Pn46}) \times 2^0 (\text{Pn4A})}{40000 (\text{Pn48})}$$

The setting ranges for Pn46, Pn47, and Pn4B, however, will be 1 to 10,000, so reduction to one of the following is required.

$$\frac{2500 (\text{Pn46}) \times 2^0 (\text{Pn4A})}{10000 (\text{Pn48})} \quad \text{or} \quad \frac{1 (\text{Pn46}) \times 2^0 (\text{Pn4A})}{4 (\text{Pn48})}$$

Make reductions so that the values fit into the setting ranges, as shown above.

### Related Parameter

The main function provided by the parameter related to electronic gears is given in the following table.

Parameter No.	Parameter name	Explanation	Reference
Pn40	Command Pulse Multiplying Setting	The command pulses are multiplied by a factor of 2 or 4 when using 90° phase difference signal inputs is selected as the input format for the command pulses in the Command Pulse Mode (Pn42).	Page 5-48

# 5-6 Brake Interlock

You can set the Brake Interlock Signal (BKIR) timing to turn ON and OFF the electromagnetic brake.

**Precautions for Correct Use**

- ♦ The electromagnetic brake of a Servomotor with a brake is a non-excitation brake designed for holding. Set the parameter to first stop the Servomotor, and then turn OFF the power supply to the brake.
- ♦ If the brake is applied while the Servomotor is rotating, the brake disk may become damaged due to friction, leading to the Servomotor malfunction.

## Parameters Requiring Setting

Parameter No.	Parameter name	Explanation	Reference
Pn6A	Brake Timing when Stopped	Use this parameter to set the output timing of the Brake Interlock Signal (BKIR) when the Servomotor is stopped.	Page 5-58
Pn6B	Brake Timing during Operation	Use this parameter to set the output timing of the Brake Interlock Signal (BKIR) when the Servomotor is rotating.	Page 5-59

## Operation

### ■ RUN Command Timing (When Servomotor Is Stopped)

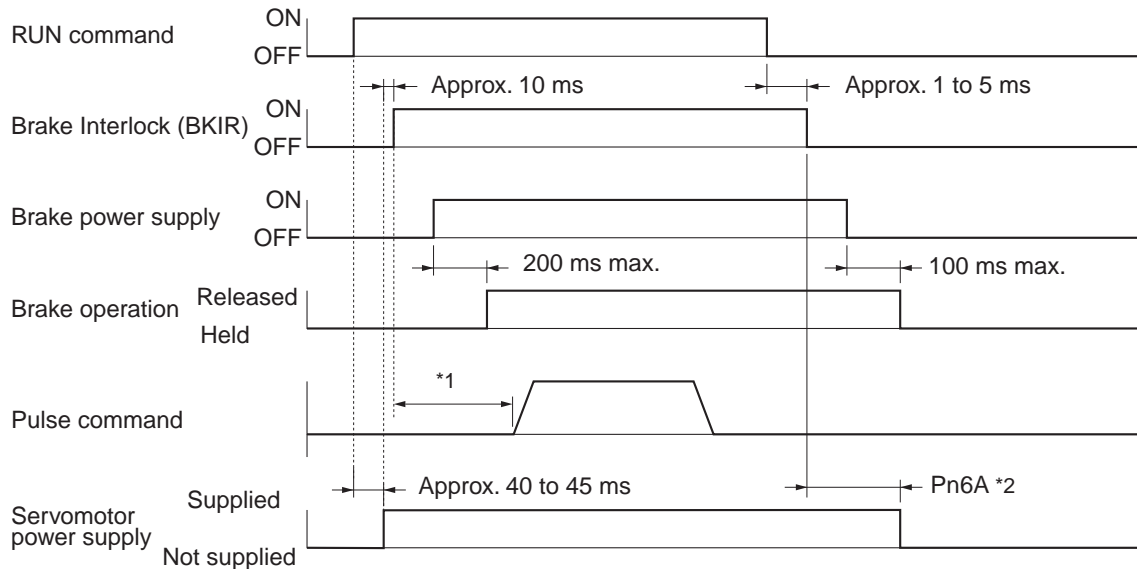

\*1. The time from turning ON the brake power supply to releasing the brake is 200 ms max. Provide a pulse command after the brake has been released, taking into account this delay.

\*2. The time from turning OFF the brake power supply to the brake engaging is 100 ms max. If using the Servomotor on a vertical axis, take this delay into account and set the Brake Timing when Stopped (Pn6A) longer so that the Servomotor power is turned OFF after the brake has been held.



## ■ RUN Command, Errors, and Power Supply Timing (When Servomotor Is Rotating)

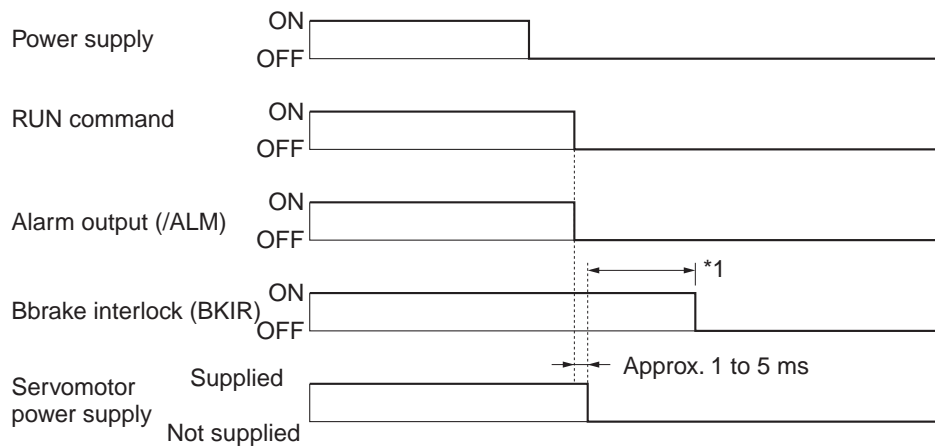

\*1. This time is the shorter value of either the setting for the Brake Timing during Operation (Pn6B) or the time it takes until the Servomotor rotation speed drops to 30 r/min or lower. Depending on the holding time of the power supply, this time may be shorter than the value set in Pn6B.

## 5-7 Gain Switching

- ♦ In Position Control Mode, you can switch between PI (proportional and integral) operation and P (proportional) operation, or between gain 1 and gain 2.
- ♦ With PI/P operation switching, the repulsion to external forces applied to the load can be weakened by eliminating the integral of the speed deviation (i.e., the difference between the speed command and speed feedback).
- ♦ Gain 1/gain 2 switching is effective in the following cases:
  - Reducing the gain to suppress vibration caused by changes in load inertia during operation.
  - Reducing the gain to suppress vibration due to an increase in speed.
  - Increasing responsiveness by increasing the gain during operation.
  - Increasing servo lock rigidity by increasing the gain when stopping.
  - Reducing the gain to suppress vibration when stopping.

### Parameters Requiring Setting

Parameter No.	Parameter name	Explanation	Reference
Pn30	Gain Switching Input Operating Mode Selection	Select whether to use PI/P operation switching or gain 1/gain 2 switching in Position Control Mode.	Page 5-44
Pn31	Gain Switch Setting	Select the condition for switching between gain 1 and gain 2.	Page 5-44
Pn32	Gain Switch Time *1	Set the delay time from the moment the condition set in the Gain Switch Setting (Pn31) is not met until returning to gain 1.	Page 5-46
Pn33	Gain Switch Level Setting *1	Set the judgment level for switching between gain 1 and gain 2. The unit for the setting depends on the condition set in the Gain Switch Setting (Pn31).	
Pn34	Gain Switch Hysteresis Setting	Set the hysteresis width above and below the judgment level set in the Gain Switch Level Setting (Pn33).	
Pn35	Position Loop Gain Switching Time	When switching between gain 1 and gain 2 is enabled, set the phased switching time only for the position loop gain at gain switching.	Page 5-47

\*1. These settings are disabled when the Gain Switch Setting (Pn31) is set to always use gain1 or gain 2 or set to the Gain Switching Input (CN1-5).

## Related Parameters

Parameter No.	Parameter name	Explanation	Reference
Pn10	Position Loop Gain	Set the position control system responsiveness. The higher the setting, the shorter the positioning time.	Page 5-36
Pn11	Speed Loop Gain	Set the speed loop responsiveness.	Page 5-37
Pn12	Speed Loop Integration Time Constant	The integration constant is included in the speed loop. This parameter functions to quickly eliminate minor speed deviations after stopping. The lower the setting, the faster the action.	Page 5-37
Pn13	Speed Feedback Filter Time Constant	The encoder signal is converted to the speed signal via the low pass filter. Noise from the Servomotor can be reduced by increasing the setting. Normally set it to 4 or less.	Page 5-37
Pn14	Torque Command Filter Time Constant	Set to adjust the primary lag filter time constant for the torque command section.	Page 5-38
Pn18	Position Loop Gain 2	These settings are for gain 2. These parameters function in the same way as the parameters described above.	Page 5-39
Pn19	Speed Loop Gain 2		Page 5-39
Pn1A	Speed Loop Integration Time Constant 2		Page 5-39
Pn1B	Speed Feedback Filter Time Constant 2		Page 5-39
Pn1C	Torque Command Filter Time Constant 2		Page 5-39

## 5-8 Torque Limit

- ◆ This function limits the output torque of the Servomotor.
- ◆ This function is effective in the following cases:
  - Pressing a moving part of a machine (such as a bending machine) against a workpiece with a constant force.
  - Protecting the Servomotor and mechanical system from excessive force or torque.
- ◆ The Warning Output Selection (Pn09) can be set to output an alarm to the Warning Output (WARN) when the torque limit function is enabled.
- ◆ Two torque limits can be set and you can switch between them. To switch the torque limit setting, enable the Torque Limit Switch Input (TLSEL) in the Zero Speed Designation/Torque Limit Switch (Pn06).

### Parameters Requiring Setting

Parameter No.	Parameter name	Explanation	Reference
Pn5E	Torque Limit *1	Set the torque limit as a percentage of the maximum torque of the Servomotor.	Page 5-54
Pn63	Deviation Counter Overflow Level	Set the alarm detection level for deviation counter overflow.	Page 5-56
Pn70	Overspeed Detection Level Setting *2	An overspeed alarm will occur if the Servomotor rotation speed exceeds the setting of this parameter.	Page 5-60

\*1. Values exceeding the default setting cannot be set. The default setting depends on the combination of the Servomotor and Servo Drive.

\*2. The Overspeed Detection Level Setting (Pn70) will function only when torque limit switching function is enabled.

### Related Parameters

The following parameters must be set to use torque limit switching function.

Parameter No.	Parameter name	Explanation	Reference
Pn71	No. 2 Torque Limit *1	These parameters are set when using the No. 2 torque limit. These parameters function in the same way as the parameters described above.	Page 5-60
Pn72	No. 2 Deviation Counter Overflow Level		
Pn73	No. 2 Overspeed Detection Level Setting *2		

\*1. Values exceeding the default setting cannot be set. The default setting depends on the combination of Servomotor and Servo Drive.

\*2. The No. 2 Overspeed Detection Level Setting (Pn73) will function only when torque limit switching function is enabled.

## 5-9 Overrun Limit

- ♦ The overrun limit function is enabled only in Position Control Mode.
- ♦ The overrun limit is used to stop operation via an alarm if the Servomotor's allowable operating range set in Overrun Limit Setting (Pn26) is exceeded.
- ♦ The overrun limit is effective in the following case:  
Preventing impact on the edges of the machine because of Servomotor oscillation.

### Parameters Requiring Settings

Parameter No.	Parameter name	Explanation	Reference
Pn26	Overrun Limit Setting	Set the operating range for the Servomotor. The overrun limit is disabled if the setting is 0.	Page 5-41

### Operation

#### ■ Servomotor Stopped (Servo Locked)

Since the Servomotor is stopped, the Servomotor's allowable operating range is within the travel distance set in the Overrun Limit Setting (Pn26) for both sides of the Servomotor stop position. If the load of the Servomotor enters the shaded area due to oscillation, an alarm will occur.

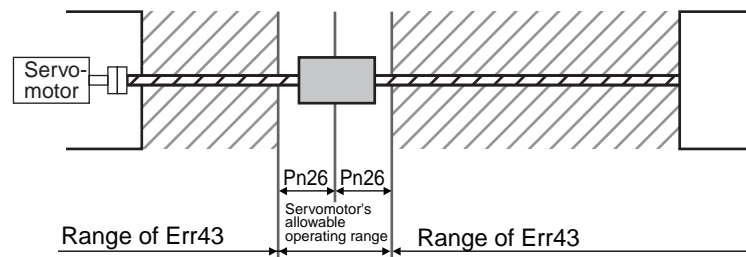

#### ■ In Operation (Traveling)

When a position command is input, the Servomotor's allowable operating range will increase according to the position command. In the following figure, an alarm will occur if the load enters the setting range on the left side before travel and the setting range on the right side after travel due to oscillation or for other reason.

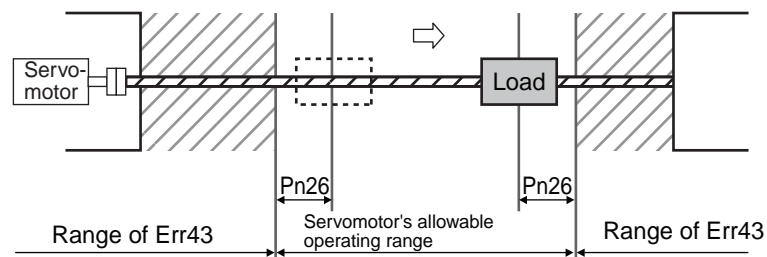

---

---

# 5-10 User Parameters

---

A Parameter Unit (R88A-PR02G) is required to set and change parameters. For information on operating procedures, refer to *6-3 Using the Parameter Unit*.

Set and check the user parameters in Parameter Setting Mode. Fully understand the parameter meanings and setting procedures before setting user parameters according to your system.

Some parameters are enabled by turning the power OFF and then ON again. When changing these parameters, turn OFF the power, check that the power LED indicator has gone OFF, and then turn ON the power again.

## Setting and Checking Parameters

### ■ Overview

Use the following procedure to set and check parameters.

#### 1. Display Parameter Setting Mode.

When the power supply is turned ON, the item set for the Default Display (Pn01) will be displayed. Press the Data key to go to Monitor Mode. Then press the Mode key to go to Parameter Setting Mode.

#### 2. Set the parameter number.

Press the Shift, Increment, and Decrement keys to set the parameter number.

#### 3. Display the parameter setting.

Press the Data key to display the setting.

#### 4. Change the parameter setting.

Press the Shift, Increment, and Decrement keys to change the displayed setting, and then press the Data key to enter the setting of the parameter.

#### 5. Save the changed setting to memory.





Press the Mode key to go to the display of Parameter Write Mode and then press the Data key to move on to Parameter Write Mode. By pressing the Increment key for at least 5 s, the set data will be written in EEPROM.

#### 6. Exit Parameter Write Mode.

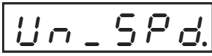

Press the Data key to return to the display of Parameter Write Mode.

## ■ Operating Procedures



### 1. Displaying Parameter Setting Mode

Key operation	Display example	Explanation
		The item set for the Default Display (Pn01) is displayed.
		Press the Data key to display Monitor Mode.
		Press the Mode key to display Parameter Setting Mode.



### 2. Setting the Parameter Number

Key operation	Display example	Explanation
		Use the Shift, Increment, and Decrement keys to set the parameter number. If the parameter number is too high, you can change the parameter number faster by using the Shift key to change the digit. The decimal point will flash for the digit that can be set.







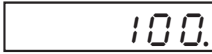

### 3. Displaying the Parameter Setting

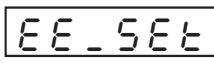
Key operation	Display example	Explanation
		Press the Data key to display the setting of the parameter.

### 4. Changing the Parameter Setting

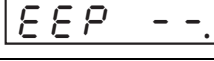
Key operation	Display example	Explanation
		Use the Shift, Increment, and Decrement keys to change the setting.
		Press the Data key to save the new setting.

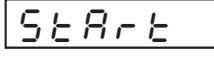
**5. Saving the New Setting to Memory**

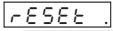
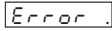
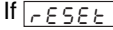
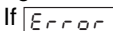
Key operation	Display example	Explanation
		Press the Mode key to display Parameter Write Mode.
		Press the Data key to move on to Parameter Write Mode.
		Press the Increment key for at least 5 s.
		The bar indicator will appear.
		Writing will start. (This display will appear only momentarily.)
		This display indicates a normal completion. In addition to "Finish," either  or  may be displayed. If  is displayed, writing has been completed normally, but some of the changed parameters will be enabled only after the power is turned ON again. Turn OFF the Servo Drive power supply and then turn it ON again. If  is displayed, there is a writing error. Write the data again.

**6. Returning to the Display of Parameter Write Mode**

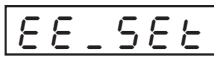
Key operation	Display example	Explanation
		Press the Data key to return to the display of Parameter Write Mode.



## Parameter List

- ♦ Some parameters are enabled by turning the power OFF and then ON again. When changing these parameters, turn OFF the power, check that the power LED indicator has gone OFF, and then turn ON the power again.
- ♦ Do not make any settings for parameters marked “Not used.”

### ■ Function Selection Parameters

Pn No.	Parameter name	Setting	Explanation	Default setting	Unit	Setting range	Power OFF→ON	
00	Unit No. Setting		Set the unit number.	1	---	1 to 15	Yes	
01	Default Display	Select the data to display on the Parameter Unit when the power supply is turned ON.		1		0 to 15	Yes	
		0	Position deviation					Pulses
		1	Servomotor rotation speed					r/min
		2	Torque output					%
		3	Control mode					---
		4	I/O signal status					---
		5	Alarm display and history					---
		6	Not used.					---
		7	Warning display					---
		8	Regeneration load ratio					%
		9	Overload load ratio					%
		10	Inertia ratio					%
		11	Total feedback pulses					Pulses
		12	Total command pulses					Pulses
		13	Not used.					---
14	Not used.	---						
15	Automatic Servomotor recognition enabled/disabled display	---						
02	Control Mode Selection	Set the control mode to be used.		2	---	0 to 2	Yes	
		0	High-response position control					
		1	Internally set speed control					
		2	Advanced position control					
03	Not used.	(Do not change setting.)		0	---	---	---	
04	Drive Prohibit Input Selection	You can prevent the Servomotor from rotating beyond its operating range by connecting limit inputs.		1	---	0 or 1	Yes	
		0	Enabled					
		1	Disabled					
05	Not used.	(Do not change setting.)		0	---	---	---	

## 5-10 User Parameters

Pn No.	Parameter name	Setting	Explanation	Default setting	Unit	Setting range	Power OFF→ON
06	Zero Speed Designation/ Torque Limit Switch	Select the function of the Zero Speed Designation Input (VZERO) and Torque Limit Switch Input (TLSEL).		1	---	0 to 2	Yes
		0	Both inputs disabled.				
		1	Zero-speed designation enabled.				
		2	Torque limit switching enabled.				
07	Not used.	(Do not change setting.)		0	---	---	---
08	Not used.	(Do not change setting.)		0	---	---	---
09	Warning Output Selection	Allocate the function of the Warning Output (WARN).		2	---	0 to 6	---
		0	Output while torque is being limited.				
		1	Output for zero speed detection.				
		2	Output for over regeneration, overload, or fan rotation speed error.				
		3	Output for over regeneration overload warning.				
		4	Output for overload warning.				
		5	Not used.				
6	Output for fan rotation speed error alarm.						
0A	Not used.	(Do not change setting.)		0	---	---	---
0B	Not used.	(Do not change setting.)		0	---	---	---
0C	Not used.	(Do not change setting.)		2	---	---	---
0D	Not used.	(Do not change setting.)		0	---	---	---
0E	Not used.	(Do not change setting.)		0	---	---	---
0F	Not used.	(Do not change setting.)		0	---	---	---

### ■ Servo Gain Parameters

Pn No.	Parameter name	Explanation	Default setting	Unit	Setting range	Power OFF→ON
10	Position Loop Gain <sup>*1</sup>	Set to adjust the position control system responsiveness.	40	1/s	0 to 32767	---
11	Speed Loop Gain <sup>*1</sup>	Set to adjust the speed loop responsiveness.	60	Hz	1 to 3500	---
12	Speed Loop Integration Time Constant <sup>*1</sup>	Set to adjust the speed loop integral time constant.	20	ms	1 to 1000	---
13	Speed Feedback Filter Time Constant <sup>*1</sup>	The encoder signal is converted to the speed signal via the low pass filter.	0	---	0 to 5	---
14	Torque Command Filter Time Constant <sup>*1</sup>	Set to adjust the primary lag filter time constant for the torque command section.	100	0.01 ms	0 to 2500	---
15	Feed-forward Amount <sup>*1</sup>	Set the position control feed-forward compensation value.	300	0.1%	-2000 to 2000	---
16	Feed-forward Command Filter <sup>*1</sup>	Set the position control feed-forward command filter.	100	0.01 ms	0 to 6400	---
17	Not used.	(Do not change setting.)	0	---	---	---
18	Position Loop Gain 2 <sup>*1</sup>	Set to adjust the position control system responsiveness.	20	1/s	0 to 32767	---
19	Speed Loop Gain 2 <sup>*1</sup>	Set to adjust the speed loop responsiveness.	80	Hz	1 to 3500	---
1A	Speed Loop Integration Time Constant 2 <sup>*1</sup>	Set to adjust the speed loop integral time constant.	50	ms	1 to 1000	---
1B	Speed Feedback Filter Time Constant 2 <sup>*1</sup>	The encoder signal is converted to the speed signal via the low pass filter.	0	---	0 to 5	---
1C	Torque Command Filter Time Constant 2 <sup>*1</sup>	Set to adjust the primary lag filter time constant for the torque command section.	100	0.01 ms	0 to 2500	---
1D	Notch Filter 1 Frequency	Set the notch frequency of the resonance suppression notch filter.	1500	Hz	100 to 1500	---
1E	Notch Filter 1 Width	Set the width to one of five levels for the resonance suppression notch filter. Normally, use the default setting.	2	---	0 to 4	---
1F	Not used.	(Do not change setting.)	0	---	---	---
20	Inertia Ratio <sup>*1</sup>	Set the ratio between the mechanical system inertia and the Servomotor rotor inertia.	300	%	0 to 10000	---

## 5-10 User Parameters

Pn No.	Parameter name	Explanation	Default setting	Unit	Setting range	Power OFF→ON	
21	Realtime Autotuning Mode Selection	Set the operating mode for realtime autotuning.	0	---	0 to 7	---	
		0					Realtime autotuning is not used. The adaptive filter is disabled.
		1					Realtime autotuning is used. Use this setting if there are almost no changes in load inertia during operation. The adaptive filter is enabled if Pn02 is set to 2.
		2					Realtime autotuning is used. Use this setting if there are gradual changes in load inertia during operation. The adaptive filter is enabled if Pn02 is set to 2.
		3					Realtime autotuning is used. Use this setting if there are sudden changes in load inertia during operation. The adaptive filter is enabled if Pn02 is set to 2.
		4					Realtime autotuning is used. Use this setting if there are almost no changes in load inertia during operation. The adaptive filter is disabled.
		5					Realtime autotuning is used. Use this setting if there are gradual changes in load inertia during operation. The adaptive filter is disabled.
		6					Realtime autotuning is used. Use this setting if there are sudden changes in load inertia during operation. The adaptive filter is disabled.
		7					Realtime autotuning is not used. The adaptive filter is enabled if Pn02 is set to 2.
22	Realtime Autotuning Machine Rigidity Selection	Set the machine rigidity during realtime autotuning to one of 16 levels. The higher the machine rigidity, the greater the setting needs to be. The higher the setting, the higher the responsiveness.	2	---	0 to 15	---	
23	Not used.	(Do not change setting.)	0	---	---	---	
24	Not used.	(Do not change setting.)	0	---	---	---	

Pn No.	Parameter name	Explanation	Default setting	Unit	Setting range	Power OFF→ ON	
25	Autotuning Operation Setting	Set the operating pattern for autotuning.	0	---	0 to 7	---	
		0					Rotation direction: CCW → CW, two rotations
		1					Rotation direction: CW → CCW, two rotations
		2					Rotation direction: CCW → CCW, two rotations
		3					Rotation direction: CW → CW, two rotations
		4					Rotation direction: CCW → CW, one rotation
		5					Rotation direction: CW → CCW, one rotation
		6					Rotation direction: CCW → CCW, one rotation
		7					Rotation direction: CW → CW, one rotation
26	Overrun Limit Setting	Set the allowable operating range for the Servomotor. The overrun limit function is disabled if this parameter is set to 0.	10	0.1 rotation	0 to 1000	---	
27	Not used.	(Do not change setting.)	0	---	---	---	
28	Not used.	(Do not change setting.)	0	---	---	---	
29	Not used.	(Do not change setting.)	0	---	---	---	
2A	Not used.	(Do not change setting.)	0	---	---	---	
2B	Vibration Frequency	Set the vibration frequency for damping to suppress vibration at the end of the load.	0	0.1Hz	0 to 5000	---	
2C	Vibration Filter Setting	Set the vibration filter for damping to suppress vibration at the end of the load.	0	0.1Hz	-200 to 2500	---	
2D	Not used.	(Do not change setting.)	0	---	---	---	
2E	Not used.	(Do not change setting.)	0	---	---	---	
2F	Adaptive Filter Table Number Display <sup>*1</sup>	Displays the table entry number corresponding to the frequency of the adaptive filter. This parameter is set automatically and cannot be changed if the adaptive filter is enabled (i.e., if the Realtime Autotuning Mode Selection (Pn21) is set to 1 to 3 or 7).	0	---	0 to 64	---	
30	Gain Switching Input Operating Mode Selection	Enable or disable gain switching. If gain switching is enabled, the setting of the Gain Switch Setting (Pn31) is used as the condition for switching between gain 1 and gain 2.	1	---	0 or 1	---	
		0					Disabled. The gain set in Pn10 to Pn14 is used, and the Gain Switch Input (GSEL) will be used to switch between PI operation and P operation.
		1					Enabled. The gain will be switched between gain 1 (Pn10 to Pn14) and gain 2 (Pn18 to Pn1C).

Pn No.	Parameter name	Explanation	Default setting	Unit	Setting range	Power OFF→ON	
31	Gain Switch Setting	Select the condition for switching between gain 1 and gain 2 in one of the position control modes. The Gain Switching Input Operating Mode Selection(Pn30) must be set to 1 (enabled).	0	---	0 to 10	---	
		0					Always gain 1
		1					Always gain 2
		2					Switching using Gain Switch Input (GSEL)
		3					Amount of change in torque command
		4					Always gain 1
		5					Command speed
		6					Amount of position deviation
		7					Command pulses received
		8					Positioning Completed Signal (INP) OFF
		9					Actual Servomotor speed
10	Combination of command pulse input and speed						
32	Gain Switch Time <sup>*1</sup>	This parameter is enabled when the Gain Switch Setting (Pn31) is set to 3, or 5 to 10. Set the delay time from the moment the condition set in the Gain Switch Setting (Pn31) is not met until returning to gain 1.	30	166 μs	0 to 10000	---	
33	Gain Switch Level Setting <sup>*1</sup>	This parameter is enabled when the Gain Switch Setting (Pn31) is set to 3, 5, 6, 9, or 10. Set the judgment level for switching between gain 1 and gain 2. The unit for the setting depends on the condition set in the Gain Switch Setting (Pn31).	600	---	0 to 20000	---	
34	Gain Switch Hysteresis Setting <sup>*1</sup>	Set the hysteresis width above and below the judgment level set in the Gain Switch Level Setting (Pn33).	50	---	0 to 20000	---	
35	Position Loop Gain Switching Time <sup>*1</sup>	When switching between gain 1 and gain 2 is enabled, set the phased switching time only for the position loop gain at gain switching.	20	166 μs	0 to 10000	---	
36	Not used.	(Do not change setting.)	0	---	---	---	
37	Not used.	(Do not change setting.)	0	---	---	---	
38	Not used.	(Do not change setting.)	0	---	---	---	
39	Not used.	(Do not change setting.)	0	---	---	---	
3A	Not used.	(Do not change setting.)	0	---	---	---	
3B	Not used.	(Do not change setting.)	0	---	---	---	
3C	Not used.	(Do not change setting.)	0	---	---	---	
3D	Not used.	(Do not change setting.)	0	---	---	---	
3E	Not used.	(Do not change setting.)	0	---	---	---	
3F	Not used.	(Do not change setting.)	0	---	---	---	

\*1. These parameters are automatically changed by executing realtime autotuning function. To set them manually, set the Realtime Autotuning Mode Selection (Pn21) to 0.

## ■ Position Control Parameters

Pn No.	Parameter name	Explanation	Default setting	Unit	Setting range	Power OFF→ ON	
40	Command Pulse Multiplying Setting	The command pulses are multiplied by a factor of 2 or 4 when using 90° phase difference signal inputs is selected as the input format for the command pulses in the Command Pulse Mode (Pn42).	4	---	1 to 4	Yes	
		1					Multiply by 2.
		2					
		3					Multiply by 4.
4							
41	Command Pulse Rotation Direction Switch	Set the Servomotor rotation direction for the command pulse input.	0	---	0 to 3	Yes	
		0					The Servomotor rotates in the direction specified by the command pulse.
		1					The Servomotor rotates in the opposite direction from the direction specified by the command pulse.
		2					The Servomotor rotates in the opposite direction from the direction specified by the command pulse.
42	Command Pulse Mode	Set the input format of the pulse sent as input commands to the Servo Drive from the position controller.	1	---	0 to 3	Yes	
		0					90° phase difference (phases A and B) signal inputs
		1					Forward pulse and reverse pulse inputs
		2					90° phase difference (phases A and B) signal inputs
		3					Feed pulse input and forward/reverse signal
43	Not used.	(Do not change setting.)	0	---	---	---	
44	Encoder Dividing Rate Setting	Set the number of encoder pulses to be output from the Servo Drive for each rotation. The setting can be made from 1 to 16,384 pulses/rotation, but the setting will not be valid if it exceeds 2,500 pulses/rotation.	2500	Pulses	1 to 16384	Yes	
45	Encoder Output Direction Switch	Set to reverse the logic of encoder pulses output from the Servo Drive.	0	---	0 or 1	Yes	
		0					Positive logic
		1					Negative logic
46	Electronic Gear Ratio Numerator 1	Set the pulse rate for command pulses and Servomotor travel distance.	10000	---	1 to 10000	---	
47	Electronic Gear Ratio Numerator 2	$\frac{\text{Electronic Gear Ratio Numerator 1 (Pn46)}}{\text{Electronic Gear Ratio Numerator 2 (Pn47)}} \times 2^{\text{Electronic Gear Ratio Numerator Exponent (Pn4A)}}$	10000	---	1 to 10000	---	
48	Not used.	(Do not change setting.)	0	---	---	---	
49	Not used.	(Do not change setting.)	0	---	---	---	

## 5-10 User Parameters

Pn No.	Parameter name	Explanation	Default setting	Unit	Setting range	Power OFF→ON
4A	Electronic Gear Ratio Numerator Exponent	Set the pulse rate for command pulses and Servomotor travel distance.  Electronic Gear Ratio Numerator 1 (Pn46)	0	---	0 to 17	---
4B	Electronic Gear Ratio Denominator	or $\times 2$ Electronic Gear Ratio Numerator Exponent (Pn4A) Electronic Gear Ratio Numerator 2 (Pn47) ----- Electronic Gear Ratio Denominator (Pn4B)	2500	---	1 to 10000	---
4C	Position Command Filter Time Constant Setting	Set the time constant for the primary lag filter for the command pulse input. If the parameter is set to 0, the filter will not function. The larger the setting, the larger the time constant.	0	---	0 to 7	---
4D	Not used.	(Do not change setting.)	0	---	---	---
4E	Smoothing Filter Setting	Select the FIR filter time constant used for the command pulse input. The larger the setting, the smoother the command pulses.	0	---	0 to 31	Yes
4F	Not used.	(Do not change setting.)	0	---	---	---



### ■ Internally Set Speed Control Parameters

Pn No.	Parameter name	Explanation	Default setting	Unit	Setting range	Power OFF → ON
50	Not used.	(Do not change setting.)	0	---	---	---
51	Not used.	(Do not change setting.)	0	---	---	---
52	Not used.	(Do not change setting.)	0	---	---	---
53	No. 1 Internally Set Speed	Set the No. 1 internally set rotation speed.	100	r/min	-20000 to 20000	---
54	No. 2 Internally Set Speed	Set the No. 2 internally set rotation speed.	200	r/min	-20000 to 20000	---
55	No. 3 Internally Set Speed	Set the No. 3 internally set rotation speed.	300	r/min	-20000 to 20000	---
56	No. 4 Internally Set Speed	Set the No. 4 internally set rotation speed.	400	r/min	-20000 to 20000	---
57	Jog Speed	Set the rotation speed for jogging.	200	r/min	0 to 500	---
58	Soft Start Acceleration Time	Set the acceleration time for internally set speed control. Set the time (setting × 2 ms) required until 1,000 r/min is reached.	0	2 ms	0 to 5000	---
59	Soft Start Deceleration Time	Set the deceleration time for internally set speed control. Set the time (setting × 2 ms) required until operation stops from 1000 r/min.	0	2 ms	0 to 5000	---
5A	Not used.	(Do not change setting.)	0	---	---	---
5B	Not used.	(Do not change setting.)	0	---	---	---
5C	Not used.	(Do not change setting.)	0	---	---	---
5D	Not used.	(Do not change setting.)	0	---	---	---
5E	Torque Limit	Set the limit to the Servomotor's maximum torque.	300	%	0 to 500	---
5F	Not used.	(Do not change setting.)	0	---	---	---

■ Sequence Parameters

Pn No.	Parameter name	Setting	Explanation	Default setting	Unit	Setting range	Power OFF→ON
60	Positioning Completion Range		Set the range for the Positioning Completed Output (INP).	25	Pulses	0 to 32767	---
61	Zero Speed Detection		Set the rotation speed for the Warning Output for zero speed detection.	20	r/min	0 to 20000	---
62	Rotation Speed for Servomotor Rotation Detection		Set the rotation speed for the Servomotor Rotation Speed Detection Output (TGON) for Internally Set Speed Control.	50	r/min	0 to 20000	---
63	Deviation Counter Overflow Level		Set the detection level for the Deviation Counter Overflow Alarm. The alarm level is the setting value multiplied by 256 pulses.	100	× 256 pulses	0 to 32767	---
64	Deviation Counter Overflow Alarm Disabled		Enable or disable the Deviation Counter Overflow Alarm.	0	---	0 or 1	---
		0	Deviation Counter Overflow Alarm enabled.				
		1	Deviation Counter Overflow Alarm disabled.				
65	Not used.		(Do not change setting.)	0	---	---	---
66	Stop Selection for Drive Prohibit Input		Set the operation used to decelerate to a stop after the Forward Drive Prohibit Input (POT) or Reverse Drive Prohibit Input (NOT) is turned ON.	0	---	0 to 2	Yes
		0	The torque in the drive prohibit direction is disabled, and the dynamic brake is activated.				
		1	The torque in the drive prohibit direction is disabled, and free-run deceleration is performed to stop.				
		2	A servo lock stop is used in position control, and a zero-speed designation stop is used in Internally Set Speed Control.				
67	Not used.		(Do not change setting.)	0	---	---	---
68	Stop Selection at Alarm		Set the operation to use during deceleration and after stopping when an alarm occurs. The deviation counter will be cleared when an alarm occurs.	0	---	0 to 3	---
		0	During deceleration: Dynamic brake After stopping: Dynamic brake				
		1	During deceleration: Free run After stopping: Dynamic brake				
		2	During deceleration: Dynamic brake After stopping: Servo free				
		3	During deceleration: Free run After stopping: Servo free				

Pn No.	Parameter name	Setting	Explanation	Default setting	Unit	Setting range	Power OFF→ ON
69	Stop Selection with Servo OFF		Set the operation to use during deceleration and after stopping and set the deviation counter status when the RUN Command Input (RUN) is turned OFF.	0	---	0 to 7	---
		0	During deceleration: Dynamic brake After stopping: Dynamic brake Deviation counter: Cleared				
		1	During deceleration: Free run After stopping: Dynamic brake Deviation counter: Cleared				
		2	During deceleration: Dynamic brake After stopping: Servo free Deviation counter: Cleared				
		3	During deceleration: Free run After stopping: Servo free Deviation counter: Cleared				
		4	During deceleration: Dynamic brake After stopping: Dynamic brake Deviation counter: Hold				
		5	During deceleration: Free run After stopping: Dynamic brake Deviation counter: Hold				
		6	During deceleration: Dynamic brake After stopping: Servo free Deviation counter: Hold				
		7	During deceleration: Free run After stopping: Servo free Deviation counter: Hold				
6A	Brake Timing When Stopped		When the Servomotor is stopped and the RUN Command Input (RUN) is turned OFF, the Brake Interlock Signal (BKIR) will turn OFF, and the Servomotor will turn OFF after the time set for this parameter elapses (i.e., setting × 2 ms).	10	2 ms	0 to 100	---
6B	Brake Timing during Operation		When the Servomotor is operating and the RUN Command Input (RUN) is turned OFF, the Servomotor will decelerate to reduce speed, and the Brake Interlock Signal (BKIR) will turn OFF after a set time (i.e., setting × 2 ms) has elapsed. BKIR will also turn OFF if the speed drops to 30 r/min or lower before the set time elapses.	50	2 ms	0 to 100	---

Pn No.	Parameter name	Setting	Explanation	Default setting	Unit	Setting range	Power OFF→ON
6C	Regeneration Resistor Selection		Set this parameter to 1 or 2 if an external generation resistor is mounted.	0	---	0 to 3	---
		0	The external regeneration processing circuit will not operate. Regenerative energy will be processed with the built-in capacitor.				
		1	An External Regeneration Resistor is used, and an External Regeneration Resistor overload alarm (alarm code 18) will occur when the resistance exceeds 10% of the operating limit.				
		2	An External Regeneration Resistor is used, but an External Regeneration Resistor overload alarm will not occur.				
		3	The external regeneration processing circuit will not operate. Regenerative energy will be processed with the built-in capacitor.				
6D	Not used.	(Do not change setting.)	0	---	---	---	
6E	Not used.	(Do not change setting.)	0	---	---	---	
6F	Not used.	(Do not change setting.)	0	---	---	---	
70	Overspeed Detection Level Setting		Set the No. 1 overspeed detection level when torque limit switching is enabled in the Zero-speed Designation/Torque Limit Switch (Pn06).	0	r/min	0 to 6000	---
71	No. 2 Torque Limit		Set the No. 2 torque limit when torque limit switching is enabled in the Zero-speed Designation/Torque Limit Switch (Pn06).	100	%	0 to 500	---
72	No. 2 Deviation Counter Overflow Level		Set the No. 2 deviation counter overflow level when torque limit switching is enabled in the Zero-speed Designation/Torque Limit Switch (Pn06).	100	× 256 pulses	1 to 32767	---
73	No. 2 Overspeed Detection Level Setting		Set the No. 2 overspeed detection level when torque limit switching is enabled in the Zero-speed Designation/Torque Limit Switch (Pn06).	0	r/min	0 to 6000	---
74	Not used.	(Do not change setting.)		0	---	---	---
75	Not used.	(Do not change setting.)		0	---	---	---
76	Not used.	(Do not change setting.)		0	---	---	---
77	Not used.	(Do not change setting.)		0	---	---	---
78	Not used.	(Do not change setting.)		0	---	---	---
79	Not used.	(Do not change setting.)		0	---	---	---
7A	Not used.	(Do not change setting.)		0	---	---	---
7B	Not used.	(Do not change setting.)		0	---	---	---
7C	Not used.	(Do not change setting.)		0	---	---	---
7D	Not used.	(Do not change setting.)		0	---	---	---
7E	Not used.	(Do not change setting.)		0	---	---	---
7F	Not used.	(Do not change setting.)		0	---	---	---

## Parameter Details

This section describes the user parameters in detail. Be sure to fully understand the meanings of the parameters and change them properly.

Do not change settings of the parameters marked "Not used."

### ■ Function Selection Parameters

Pn00	Unit No. Setting							All modes
Setting range	1 to 15	Unit	---	Default setting	1	Power OFF → ON	Yes	

♦ Use this parameter to set the unit number.

Pn01	Default Display							All modes
Setting range	0 to 15	Unit	Refer to the following table.	Default setting	1	Power OFF → ON	Yes	

♦ Use this parameter to set the item to be displayed on the Parameter Unit when the power supply is turned ON.

### Explanation of Settings

Setting	Explanation		Unit
0	Position deviation	Displays the number of accumulated pulses in the deviation counter.	Pulse
1	Servomotor rotation speed	Displays the Servomotor rotation speed.	r/min
2	Torque output	Displays the Servomotor output torque as a percentage of the rated torque output.	%
3	Control mode	Displays the control mode, i.e., position control or Internally Set Speed Control.	---
4	I/O signal status	Displays the status of control input and output signals connected to CN1.	---
5	Alarm display and history	Displays the 14 most recent alarms, including current alarms.	---
6	Not used.		---
7	Warning display	Displays overload and over regeneration warnings.	---
8	Regeneration load ratio	Displays the load ratio as a percentage of the regeneration overload alarm operation level.	%
9	Overload load ratio	Displays the load ratio as a percentage of the rated load.	%
10	Inertia ratio	Displays the inertia ratio.	%
11	Total feedback pulses	Displays the total number of pulses since the power supply was turned ON. Press the Data key for 5 s or longer to reset the value.	Pulse
12	Total command pulses		Pulse
13	Not used.		---
14	Not used.		---
15	Automatic Servomotor recognition display	Automatic Servomotor recognition is always enabled.	---

Pn02	Control Mode Selection <span style="float: right; border: 1px solid black; padding: 2px;">All modes</span>						
Setting range	0 to 2	Unit	---	Default setting	2	Power OFF → ON	Yes

♦ Set the control mode to be used.

**Explanation of Settings**

Setting	Explanation
0	High-response Position Control
1	Internally Set Speed Control
2	Advanced Position Control

**Differences between High-response Position Control and Advanced Position Control**

	Notch Filter 1 Frequency (Pn1D)	Vibration Frequency (Pn2B)	Realtime Autotuning Mode Selection (Pn21)	Adaptive Filter Table Number Display(Pn2F)
High-response Position Control	Conditional	Conditional	Conditional	Disabled
Advanced Position Control	Enabled	Enabled	Enabled	Enabled

♦ The Notch Filter 1 Frequency, Vibration Frequency, and Realtime Autotuning Mode Selection cannot be used at the same time in High-response Position Control Mode. The parameter entered first will be given priority.

Example:

When the Realtime Autotuning Mode Selection is set, the Servo Drive will be forcibly set to 1500 (disabled), even if the Notch Filter 1 Frequency is input.

♦ The adaptive filter is disabled in High-response Position Control Mode. To use the adaptive filter, use the Advanced Position Control Mode.

Pn03	Not used. (Do not change setting.)
------	------------------------------------

Pn04	Drive Prohibit Input Selection <span style="float: right; border: 1px solid black; padding: 2px;">All modes</span>						
Setting range	0 or 1	Unit	---	Default setting	1	Power OFF → ON	Yes

- ♦ Set whether to use the drive prohibit inputs.
- ♦ You can prevent the Servomotor from rotating beyond the device's operating range by connecting limit inputs.
- ♦ When only the Forward Drive Prohibit Input (POT) is turned ON, the Servomotor can operate in the forward direction, but cannot operate in the reverse direction.

**Explanation of Settings**

Setting	Explanation
0	Drive prohibit inputs enabled. When the Forward Drive Prohibit Input (POT) and the Reverse Drive Prohibit Input (NOT) are ON, the Servomotor can operate in the forward and reverse directions.
1	Drive prohibit inputs disabled. Operation is possible regardless of the POT and NOT inputs.

Pn05	Not used. (Do not change setting.)						
------	------------------------------------	--	--	--	--	--	--

Pn06	Zero Speed Designation/Torque Limit Switch						All modes
Setting range	0 to 2	Unit	---	Default setting	1	Power OFF → ON	Yes

- ♦ Use this parameter to select whether to use the Zero Speed Designation Input (VZERO) or Torque Limit Switch Input (TLSEL) as the function of pin CN1-5.
- ♦ For Position Control Mode, 0 or 2 can be selected. For Internally Set Speed Control Mode, 1 or 2 can be selected.
- ♦ If 0 is selected in Position Control Mode, pin CN1-5 will be used as the Gain Switch Input (GSEL).
- ♦ If the Torque Limit Switch Input (TLSEL) is used, always set the following parameters: Overspeed Detection Level Setting (Pn70), No. 2 Torque Limit (Pn71), and No. 2 Overspeed Detection Level Setting (Pn73). If the Torque Limit Switch Input is used with the default settings, an overspeed alarm (alarm code 26) will occur.

**Explanation of Settings**

Setting	Explanation	
	Zero Speed Designation Input (VZERO)	Torque Limit Switch Input (TLSEL)
0	Disabled	Disabled
1	Enabled	Disabled
2	Disabled	Enabled

Pn07	Not used. (Do not change setting.)						
------	------------------------------------	--	--	--	--	--	--

Pn08	Not used. (Do not change setting.)						
------	------------------------------------	--	--	--	--	--	--

Pn09	Warning Output Selection						All modes
Setting range	0 to 6	Unit	---	Default setting	2	Power OFF → ON	---

- ♦ Set the function of the Warning Output (WARN).

**Explanation of Settings**

Setting	Explanation
0	Output while torque is being limited.
1	Output for zero speed detection.
2	Output for regeneration, overload, or fan rotation speed alarm warning.
3	Output for regeneration warning.
4	Output for overload warning.
5	Not Used.
6	Output for fan rotation speed alarm warning.

## 5-10 User Parameters

---

Pn0A	Not used. (Do not change setting.)
Pn0B	Not used. (Do not change setting.)
Pn0C	Not used. (Do not change setting.)
Pn0D	Not used. (Do not change setting.)
Pn0E	Not used. (Do not change setting.)
Pn0F	Not used. (Do not change setting.)



■ Gain Parameters

Pn10	Position Loop Gain					Position
Setting range	0 to 32767	Unit	1/s	Default setting	40	Power OFF → ON ---

- ◆ Set this parameter to adjust the position loop response according to the mechanical rigidity.
- ◆ The responsiveness of the servo system is determined by the position loop gain. Servo systems with a high loop gain have a high response and can make positioning faster. To increase the position loop gain, you must improve mechanical rigidity and increase the specific oscillation frequency. The value should be 50 to 70 (1/s) for ordinary machine tools, 30 to 50 (1/s) for general-use and assembly machines, and 10 to 30 (1/s) for industrial robots. Since the default position loop gain is 40 (1/s), be sure to lower the setting for machines with low rigidity.
- ◆ Increasing the position loop gain in systems with low mechanical rigidity or systems with low specific oscillation frequencies may cause machine resonance, resulting in an overload alarm.
- ◆ If the position loop gain is low, you can shorten the positioning time by using feed forward.
- ◆ This parameter is automatically changed by executing realtime autotuning function. To set it manually, set the Realtime Autotuning Mode Selection (Pn21) to 0.
- ◆ Position loop gain is generally calculated as follows:

$$\text{Position loop gain (Kp)} = \frac{\text{Command pulse frequency (pulses/s)}}{\text{Deviation counter accumulated pulses (pulses)}} \text{ (1/s)}$$

When the position loop gain is changed, the response is as shown in the following diagram.

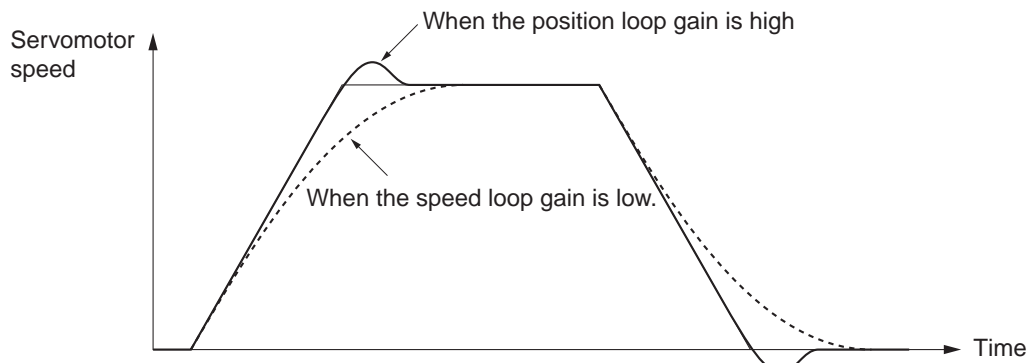

- ◆ If the speed loop gain and position loop gain are optimally set, the Servomotor operation for the command will be delayed  $2/Kp$  at acceleration and delayed  $3/Kp$  at deceleration.

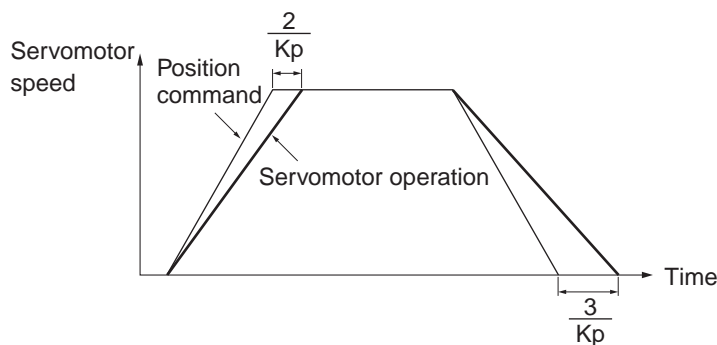

## 5-10 User Parameters

Pn11	Speed Loop Gain					All modes	
Setting range	1 to 3500	Unit	Hz	Default setting	60	Power OFF → ON	---

- ◆ This gain adjusts the speed loop response.
- ◆ Increase the gain to increase servo rigidity. Generally, the greater the inertia ratio, the higher the setting. If the gain is too high, it causes oscillation.
- ◆ This parameter is automatically changed by executing realtime autotuning function. To set it manually, set the Realtime Autotuning Mode Selection (Pn21) to 0.

When the speed loop gain is changed, the response is as shown in the following diagram.

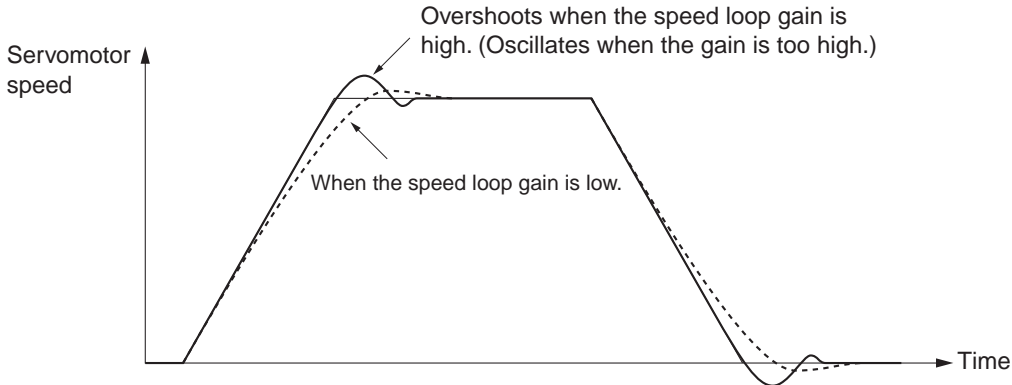

Pn12	Speed Loop Integration Time Constant					All modes	
Setting range	1 to 1000	Unit	ms	Default setting	20	Power OFF → ON	---

- ◆ Set the speed loop integration time constant.
- ◆ The higher the setting, the lower the responsiveness and the lower the resiliency to external force. If the setting is too low, it causes oscillation.
- ◆ This parameter is automatically changed by executing realtime autotuning function. To set it manually, set the Realtime Autotuning Mode Selection (Pn21) to 0.

When the speed loop integration time constant is changed, the response is as shown in the following diagram.

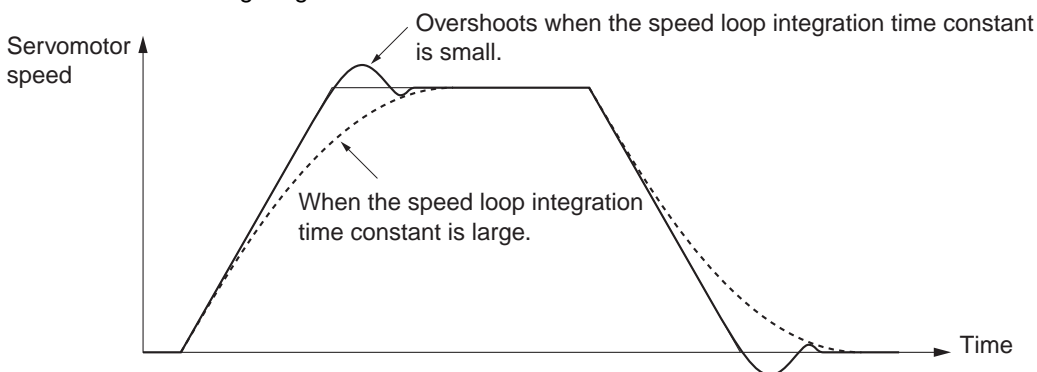

Pn13	Speed Feedback Filter Time Constant					All modes	
Setting range	1 to 5	Unit	---	Default setting	0	Power OFF → ON	---

- ◆ The encoder signal is converted to the speed signal via the low pass filter.
- ◆ The higher the setting, the higher the time constant and the lower the noise level generated by the Servomotor. Normally, use a setting of 4 or less.
- ◆ This parameter is automatically changed by executing realtime autotuning function. To set it manually, set the Realtime Autotuning Mode Selection (Pn21) to 0.

Pn14	Torque Command Filter Time Constant							All modes
Setting range	0 to 2500	Unit	× 0.01 ms	Default setting	100	Power OFF → ON	---	

- ♦ Set this parameter to adjust the primary lag filter time constant for the torque command.
- ♦ This parameter is automatically changed by executing realtime autotuning function. To set it manually, set the Realtime Autotuning Mode Selection (Pn21) to 0.

Pn15	Feed-forward Amount							Position
Setting range	-2000 to 2000	Unit	× 0.1%	Default setting	300	Power OFF → ON	---	

- ♦ Set the feed-forward compensation value during position control.
- ♦ When performing feed-forward compensation, the effective servo gain increases, improving responsiveness. There is almost no effect, however, on systems whose position loop gain is sufficiently high.
- ♦ Use this parameter to shorten positioning time.
- ♦ Setting a high value may result in machine vibration. Set the feed-forward amount for general machinery to 80% maximum. (Make adjustments while checking machine response.)
- ♦ This parameter is automatically changed by executing realtime autotuning function. To set it manually, set the Realtime Autotuning Mode Selection (Pn21) to 0.

Pn16	Feed-forward Command Filter							Position
Setting range	0 to 6400	Unit	× 0.01 ms	Default setting	100	Power OFF → ON	---	

- ♦ Set the feed-forward (primary lag) command filter to use during position control.
- ♦ If the Positioning Completed Signal (INP) is interrupted (i.e., repeatedly turns ON and OFF) because of feed-forward compensation, and speed overshooting occurs, the problem may be solved by setting the primary lag filter.
- ♦ This parameter is automatically changed by executing realtime autotuning function. To set it manually, set the Realtime Autotuning Mode Selection (Pn21) to 0.

Pn17	Not used. (Do not change setting.)						
------	------------------------------------	--	--	--	--	--	--

## 5-10 User Parameters

Pn18	Position Loop Gain 2						Position
Setting range	0 to 32767	Unit	1/s	Default setting	20	Power OFF → ON	---
Pn19	Speed Loop Gain 2						All modes
Setting range	1 to 3500	Unit	Hz	Default setting	80	Power OFF → ON	---
Pn1A	Speed Loop Integration Time Constant 2						All modes
Setting range	1 to 1000	Unit	ms	Default setting	50	Power OFF → ON	---
Pn1B	Speed Feedback Filter Time Constant 2						All modes
Setting range	0 to 5	Unit	---	Default setting	0	Power OFF → ON	---
Pn1C	Torque Command Filter Time Constant 2						All modes
Setting range	0 to 2500	Unit	× 0.01 ms	Default setting	100	Power OFF → ON	---

- ◆ These parameters are for the gain and time constants selected when gain switching is enabled in the Gain Switching Input Operating Mode Selection (Pn30).
- ◆ The gain is switched according to the condition set in the Gain Switch Setting (Pn31).
- ◆ If the mechanical system inertia changes greatly or if you want to change the responsiveness while the Servomotor is rotating and stopped, you can achieve the appropriate control by setting the gains and time constants beforehand for each condition, and switch between them according to the condition.
- ◆ These parameters are automatically changed by executing realtime autotuning function. To set them manually, set the Realtime Autotuning Mode Selection (Pn21) to 0.
- ◆ Gain switching function is enabled only for position control. For Internally Set Speed Control, operation will be performed using gain 1 (Pn11, Pn12, Pn13, and Pn14).

Pn1D	Notch Filter 1 Frequency						All modes
Setting range	100 to 1500	Unit	Hz	Default setting	1500	Power OFF → ON	---

- ◆ Set the notch frequency of the resonance suppression notch filter.
- ◆ Set this parameter to approximately 10% lower than the resonance frequency of the mechanical system.
- ◆ The notch filter function will be disabled if this parameter is set to 1500.

Pn1E	Notch Filter 1 Width						All modes
Setting range	0 to 4	Unit	---	Default setting	2	Power OFF → ON	---

- ◆ Set the width to one of five levels for the resonance suppression notch filter.
- ◆ Increasing the setting increases the width.
- ◆ Normally, use the default setting.

Pn1F	Not used. (Do not change setting.)						
------	------------------------------------	--	--	--	--	--	--

Pn20	Inertia Ratio						All modes
Setting range	0 to 10000	Unit	%	Default setting	300	Power OFF → ON	---

- ♦ Set the mechanical system inertia (load inertia at the Servomotor shaft) as a percentage of the Servomotor rotor inertia.
- ♦ This parameter is automatically changed by executing autotuning.
- ♦ This parameter is automatically changed by executing realtime autotuning function. To set it manually, set the Realtime Autotuning Mode Selection (Pn21) to 0.
- ♦ When realtime autotuning is performed, the estimated inertia ratio is saved in EEPROM every 30 minutes.
- ♦ If the inertia ratio is set correctly, the setting unit for Speed Loop Gain (Pn11) and Speed Loop Gain 2 (Pn19) will be Hz. If the Inertia Ratio (Pn20) is set larger than the actual value, the setting for speed loop gain will increase. If the inertia ratio is set smaller than the actual value, the setting for speed loop gain will decrease.

Pn21	Realtime Autotuning Mode Selection						All modes
Setting range	0 to 7	Unit	---	Default setting	0	Power OFF → ON	---

- ♦ Set the operating mode for realtime autotuning.
- ♦ The higher the setting value is (e.g., 3 or 6), the faster the response is to a change in inertia during operation. Operation, however, may become unstable depending on the operating pattern. Normally, set the parameter to 1 or 4.
- ♦ To enable the adaptive filter, the Control Mode Selection (Pn02) must be set to 2 (advanced position control).
- ♦ The adaptive filter table entry number display will be reset to 0 if the adaptive filter is disabled.
- ♦ Changes to this parameter are enabled when the Servo status shifts from OFF to ON.
- ♦ The Notch Filter 1 Frequency (Pn1D) and Vibration Frequency (Pn2B) must be disabled if realtime autotuning function is used with the Control Mode Selection (Pn02) set to 0 (high-response position control).

### Explanation of Settings

Setting	Realtime autotuning	Degree of change in load inertia during operation	Adaptive filter
0	Not used.	---	Disabled
1	Used.	There is almost no change.	Enabled (Pn02 = 2)
2		There are gradual change.	
3		There are sudden changes.	
4		There is almost no change.	Disabled
5		There are gradual changes.	
6		There are sudden changes.	
7	Not used.	---	Enabled (Pn02 = 2)

## 5-10 User Parameters

Pn22	Realtime Autotuning Machine Rigidity Selection							All modes
Setting range	0 to 15	Unit	---	Default setting	2	Power OFF → ON	---	

- ◆ Set the machine rigidity to one of 16 levels for executing realtime autotuning.
- ◆ The greater the machine rigidity, the higher the setting. The higher the setting, the higher the responsiveness.
- ◆ If the setting is changed suddenly by a large amount, the gain will change rapidly, subjecting the machine to shock. Always start with a small value in the setting, and gradually increase the setting while monitoring machine operation.

Pn23	Not used. (Do not change setting.)						
------	------------------------------------	--	--	--	--	--	--

Pn24	Not used. (Do not change setting.)						
------	------------------------------------	--	--	--	--	--	--

Pn25	Autotuning Operation Setting							All modes
Setting range	0 to 7	Unit	---	Default setting	0	Power OFF → ON	---	

- ◆ Set the operating pattern for autotuning.

### Explanation of Settings

Setting	Rotation direction	Number of rotations
0	CCW → CW	Two rotations
1	CW → CCW	
2	CCW → CCW	
3	CW → CW	One rotation
4	CCW → CW	
5	CW → CCW	
6	CCW → CCW	
7	CW → CW	

Pn26	Overrun Limit Setting							Position
Setting range	0 to 1000	Unit	× 0.1 rotation	Default setting	10	Power OFF → ON	---	

- ◆ Set the allowable operating range for the Servomotor.
- ◆ The overrun limit function is disabled if the setting is 0.
- ◆ For details, refer to *Overrun Limit* on page 5-16.

Pn27	Not used. (Do not change setting.)						
------	------------------------------------	--	--	--	--	--	--

Pn28	Not used. (Do not change setting.)						
------	------------------------------------	--	--	--	--	--	--

Pn29	Not used. (Do not change setting.)						
------	------------------------------------	--	--	--	--	--	--

Pn2A	Not used. (Do not change setting.)						
------	------------------------------------	--	--	--	--	--	--

Pn2B	Vibration Frequency						Position
Setting range	0 to 5000	Unit	× 0.1 Hz	Default setting	0	Power OFF → ON	---

- ♦ Set vibration frequency for damping control to suppress vibration at the end of the load.
- ♦ The minimum frequency that can be set is 100 (10.0 Hz). The parameter will be disabled if it is set to 0 to 99.
- ♦ The Notch Filter 1 Frequency (Pn1D) and Realtime Autotuning Mode Selection (Pn21) must be disabled if damping control function is used with the Control Mode Selection (Pn02) set to 0 (high-response position control).
- ♦ For details, refer to *Damping Control* on page 7-23.

Pn2C	Vibration Filter Setting						Position
Setting range	-200 to 2500	Unit	× 0.1 Hz	Default setting	0	Power OFF → ON	---

- ♦ Set the vibration filter for damping control to suppress vibration at the end of the load.
- ♦ When the Vibration Frequency (Pn2B) is set, set a small value if torque saturation occurs and set a large value to achieve faster positioning.
- ♦ Normally, set the parameter to 0.
- ♦ For details, refer to *Damping Control* on page 7-23.

Pn2D	Not used. (Do not change setting.)
Pn2E	Not used. (Do not change setting.)

Pn2F	Adaptive Filter Table Number Display						Advanced position
Setting range	0 to 64	Unit	---	Default setting	0	Power OFF → ON	---

- ♦ This parameter displays the table entry number corresponding to the frequency of the adaptive filter.
- ♦ This parameter is set automatically and cannot be changed if the adaptive filter is enabled in the Realtime Autotuning Mode Selection (Pn21).
- ♦ When the adaptive filter is enabled, data will be saved in EEPROM every 30 minutes. If the adaptive filter is enabled the next time the power supply is turned ON, adaptive operation will start with the data saved in the EEPROM as the default value.
- ♦ To reset the adaptive filter when operation is not normal, set the Realtime Autotuning Mode Selection (Pn21) to 0 or to between 4 and 6 and disable the filter, and enable it again.
- ♦ If the display for this parameter is 49 or higher, the adaptive filter may be automatically disabled depending on the Realtime Autotuning Machine Rigidity Selection (Pn22).

### Explanation of Settings

Dis-played value	Notch Filter 1 Frequency (Hz)	Dis-played value	Notch Filter 1 Frequency (Hz)	Dis-played value	Notch Filter 1 Frequency (Hz)
0	Disabled	22	766	44	326
1	Disabled	23	737	45	314
2	Disabled	24	709	46	302
3	Disabled	25	682	47	290
4	Disabled	26	656	48	279
5	1482	27	631	49	269 (Disabled when Pn22 ≥ F)
6	1426	28	607	50	258 (Disabled when Pn22 ≥ F)
7	1372	29	584	51	248 (Disabled when Pn22 ≥ F)
8	1319	30	562	52	239 (Disabled when Pn22 ≥ F)
9	1269	31	540	53	230 (Disabled when Pn22 ≥ F)
10	1221	32	520	54	221 (Disabled when Pn22 ≥ E)
11	1174	33	500	55	213 (Disabled when Pn22 ≥ E)
12	1130	34	481	56	205 (Disabled when Pn22 ≥ E)
13	1087	35	462	57	197 (Disabled when Pn22 ≥ E)
14	1045	36	445	58	189 (Disabled when Pn22 ≥ E)
15	1005	37	428	59	182 (Disabled when Pn22 ≥ D)
16	967	38	412	60	Disabled
17	930	39	396	61	Disabled
18	895	40	381	62	Disabled
19	861	41	366	63	Disabled
20	828	42	352	64	Disabled
21	796	43	339		



Pn30	Gain Switching Input Operating Mode Selection							Position
Setting range	0 or 1	Unit	---	Default setting	1	Power OFF → ON	---	

- ◆ Set this parameter to enable or disable gain switching.
- ◆ If gain switching is disabled, the gain switching input can be used to switch between PI operation and P operation.
- ◆ If gain switching is enabled, the setting of the Gain Switch Setting (Pn31) is used as the condition for switching between gain 1 and gain 2.

### Explanation of Settings

Setting	Explanation
0	Gain switching is disabled. Gain 1 (Pn10 to Pn14) is used, and the Gain Switch Input (GSEL) will be used to switch between PI operation and P operation.
1	Gain switching is enabled. The gain will be switched between gain 1 in (Pn10 to Pn14) and gain 2 (Pn18 to Pn1C).

Pn31	Gain Switch Setting							Position
Setting range	0 to 10	Unit	---	Default setting	0	Power OFF → ON	---	

- ◆ Select the condition for switching between gain 1 and gain 2.
- ◆ The Gain Switch Input Operating Mode Selection (Pn30) must be set to 1 to enable gain switching.

### Explanation of Settings

(○: Enabled, ×: Disabled)

Setting	Explanation			
	Gain switching conditions	Gain Switch Time (Pn32) <sup>*1</sup>	Gain Switch Level Setting	Gain Switch Hysteresis Setting (Pn34) <sup>*2</sup>
0	Always gain 1 (Pn10 to Pn14)	×	×	×
1	Always gain 2 (Pn18 to Pn1C)	×	×	×
2	Switching using Gain Switch Input (GSEL) for pin CN1-5.	×	×	×
3	Amount of change in torque command (Figure A)	○	○ <sup>*3</sup> (× 0.05%)	○ <sup>*3</sup> (× 0.05%)
4	Always gain 1 (Pn10 to Pn14)	×	×	×
5	Command speed (Figure B)	○	○ (r/min)	○ (r/min)
6	Amount of position deviation (Figure C)	○	○ <sup>*4</sup> (Pulse)	○ <sup>*4</sup> (Pulse)
7	Command pulses received (Figure D)	○	×	×
8	Positioning Completed Output (INP) OFF (Figure E)	○	×	×
9	Actual Servomotor speed (Figure B)	○	○ (r/min)	○ (r/min)
10	Combination of command pulse input and speed (Figure F)	○	○ <sup>*5</sup> (r/min)	○ <sup>*5</sup> (r/min)

- \*1. The Gain Switch Time (Pn32) is used when returning from gain 2 to gain 1.
- \*2. The Gain Switch Hysteresis Setting (Pn34) is defined as shown in the following figure.

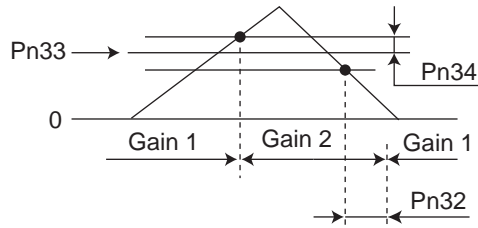

- \*3. The amount of change is the value within 166  $\mu$ s.  
Example: When the condition is a 10% change in torque in 166  $\mu$ s, the set value is 200.
- \*4. This is the encoder resolution.
- \*5. The meanings of the Gain Switch Time, Gain Switch Level Setting, and Gain Switch Hysteresis Setting are different from normal if this parameter is set to 10. (Refer to Figure F.)

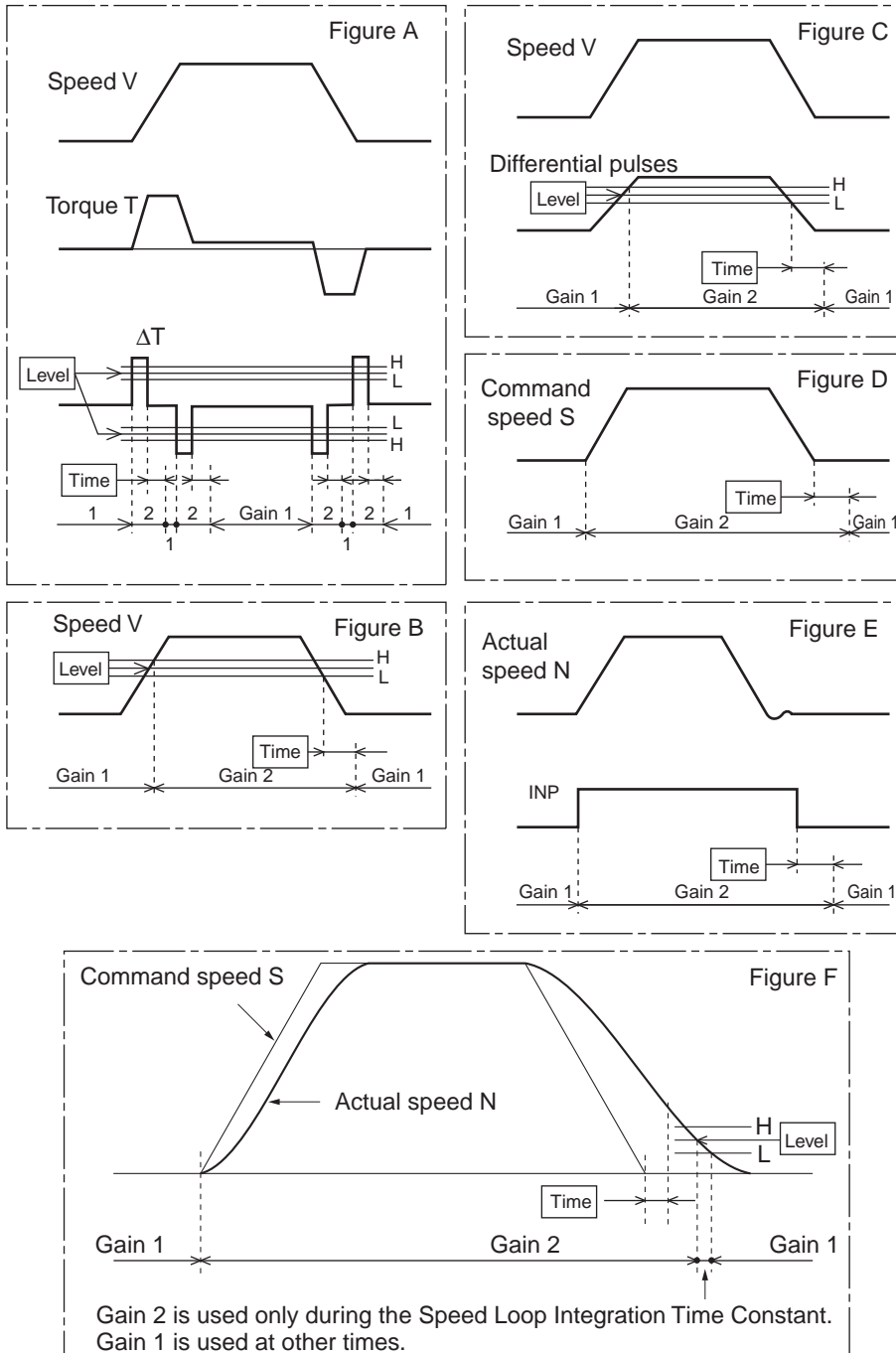

Pn32	Gain Switch Time						Position
Setting range	0 to 10000	Unit	× 166 μs	Default setting	30	Power OFF → ON	---

- ♦ This parameter is enabled when the Gain Switch Setting (Pn31) is set to 3, or 5 to 10. Set the delay time from the moment the condition set in the Gain Switch Setting (Pn31) is not met until returning to gain 1.
- ♦ This parameter is automatically changed by executing realtime autotuning function. To set it manually, set the Realtime Autotuning Mode Selection (Pn21) to 0.

Pn33	Gain Switch Level Setting						Position
Setting range	0 to 20000	Unit	---	Default setting	600	Power OFF → ON	---

- ♦ This parameter is enabled when the Gain Switch Setting (Pn31) is set to 3, 5, 6, 9, or 10. Set the judgment level for switching between gain 1 and gain 2.
- ♦ The unit for the setting depends on the condition set in the Gain Switch Setting (Pn31).
- ♦ This parameter is automatically changed by executing realtime autotuning function. To set it manually, set the Realtime Autotuning Mode Selection (Pn21) to 0.

Pn34	Gain Switch Hysteresis Setting						Position
Setting range	0 to 20000	Unit	---	Default setting	50	Power OFF → ON	---

- ♦ Set the hysteresis width above and below the judgment level set in the Gain Switch Level Setting (Pn33).
- ♦ The Gain Switch Hysteresis Setting (Pn34) is defined as shown in the following figure.

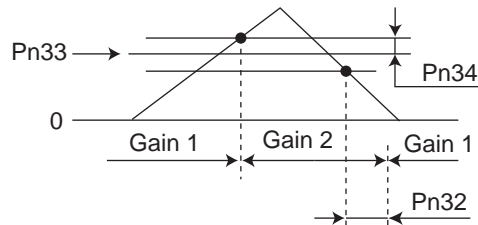

- ♦ This parameter is automatically changed by executing realtime autotuning function. To set it manually, set the Realtime Autotuning Mode Selection (Pn21) to 0.

## 5-10 User Parameters

Pn35	Position Loop Gain Switching Time					Position
Setting range	0 to 10000	Unit	(Setting + 1) (× 166 μs)	Default setting	20	Power OFF → ON ---

- ♦ If the Gain Switching Input Operating Mode Selection (Pn30) is set to 1 (gain switching enabled), set the phased switching time only for position loop gain at gain switching.

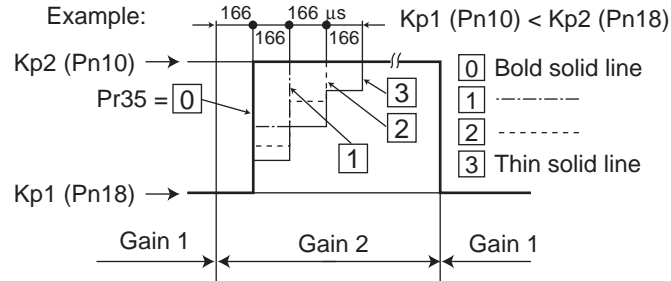

- ♦ The switching time is set only when switching from a small position loop gain to a large position loop gain (Kp1 to Kp2). This is to reduce the shock to the machine due to sudden changes in the gain.
- ♦ Set a value smaller than the difference between Kp2 and Kp1.
- ♦ This parameter is automatically changed by executing realtime autotuning function. To set it manually, set the Realtime Autotuning Mode Selection (Pn21) to 0.

Pn36	Not used. (Do not change setting.)
Pn37	Not used. (Do not change setting.)
Pn38	Not used. (Do not change setting.)
Pn39	Not used. (Do not change setting.)
Pn3A	Not used. (Do not change setting.)
Pn3B	Not used. (Do not change setting.)
Pn3C	Not used. (Do not change setting.)
Pn3D	Not used. (Do not change setting.)
Pn3E	Not used. (Do not change setting.)
Pn3F	Not used. (Do not change setting.)

## ■ Position Control Parameters

Pn40	Command Pulse Multiplying Setting						Position
Setting range	1 to 4	Unit	---	Default setting	4	Power OFF → ON	Yes

- ♦ The command pulses are multiplied by a factor of 2 or 4 when 90° phase difference signal inputs are selected as the input format for the command pulses in the Command Pulse Mode (Pn42).

### Explanation of Settings

Setting	Explanation
1	Multiply the input pulses by 2.
2	
3	Multiply the input pulses by 4.
4	

Pn41	Command Pulse Rotation Direction Switch						Position
Setting range	0 to 3	Unit	---	Default setting	0	Power OFF → ON	Yes

- ♦ Set the Servomotor rotation direction used for the command pulse input.

### Explanation of Setting

Setting	Explanation
0	The Servomotor rotates in the direction specified by the command pulse.
1	The Servomotor rotates in the opposite direction of the direction specified by the command pulse.
2	
3	The Servomotor rotates in the direction specified by the command pulse.

Pn42	Command Pulse Mode					Position	
Setting range	0 to 3	Unit	---	Default setting	1	Power OFF → ON	Yes

♦ Set the input format of the pulse inputs sent as commands to the Servo Drive from the position controller.

**Explanation of Setting**

Setting	Command pulse mode	Servomotor forward command	Servomotor reverse command
0 or 2	90° phase difference (phases A and B) signal inputs	<p>Phase A <math>t_1</math> <math>t_1</math></p> <p>Phase B <math>t_1</math> <math>t_1</math></p> <p>Line driver: <math>t_1 \geq 2 \mu\text{s}</math> Open collector: <math>t_1 \geq 5 \mu\text{s}</math></p>	
1	Forward pulse and reverse pulse inputs	<p>Low <math>t_2</math> <math>t_2</math></p> <p>Low <math>t_2</math> <math>t_2</math></p> <p>Line driver: <math>t_2 \geq 1 \mu\text{s}</math> Open collector: <math>t_2 \geq 2.5 \mu\text{s}</math></p>	
3	Feed pulse input and forward/reverse signal	<p>High <math>t_2</math> <math>t_2</math></p> <p>Low <math>t_2</math> <math>t_2</math></p> <p>Line driver: <math>t_2 \geq 1 \mu\text{s}</math> Open collector: <math>t_2 \geq 2.5 \mu\text{s}</math></p>	

Pn43	Not used. (Do not change setting.)						
------	------------------------------------	--	--	--	--	--	--

Pn44	Encoder Dividing Rate Setting					All modes	
Setting range	1 to 16384	Unit	Pulse	Default setting	2500	Power OFF → ON	Yes

- ♦ Set the number of encoder pulses to be output from the Servo Drive for each rotation.
- ♦ The setting can be made from 1 to 16,384 pulses, but the setting will not be valid if it exceeds 2,500 pulses. (Any setting that exceeds the encoder resolution will be invalid.)
- ♦ Even if the dividing rate is changed, there will always be 1 pulse per rotation for phase Z.

Pn45	Encoder Output Direction Switch						All modes
Setting range	0 or 1	Unit	---	Default setting	0	Power OFF → ON	Yes

- ◆ This parameter can be used to reverse the logic of the encoder pulses output from the Servo Drive.
- ◆ Phase Z is synchronized with phase A. The logic of phase Z cannot be reversed.

**Explanation of Settings**

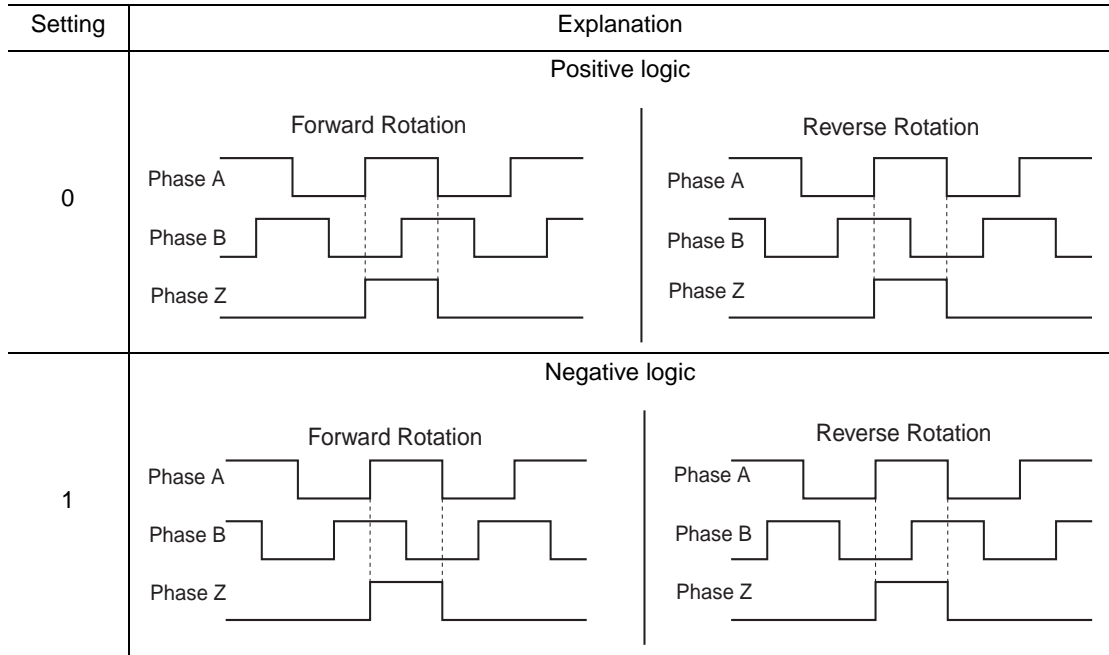

Pn46	Electronic Gear Ratio Numerator 1						Position
Setting range	1 to 10000	Unit	---	Default setting	10000	Power OFF → ON	---

Pn47	Electronic Gear Ratio Numerator 2						Position
Setting range	1 to 10000	Unit	---	Default setting	10000	Power OFF → ON	---

- ◆ Set the pulse rate for command pulses and Servomotor travel distance along with Pn4A and Pn4B.

$$\frac{\text{Electronic Gear Ratio Numerator 1 (Pn46)} \quad \text{or} \quad \text{Electronic Gear Ratio Numerator Exponent (Pn4A)} \times 2}{\text{Electronic Gear Ratio Numerator 2 (Pn47)}} \times \text{Electronic Gear Ratio Denominator (Pn4B)}$$

- ◆ For details, refer to *Electronic Gear* on page 5-9.

Pn48	Not used. (Do not change setting.)
------	------------------------------------

Pn49	Not used. (Do not change setting.)
------	------------------------------------

## 5-10 User Parameters

Pn4A	Electronic Gear Ratio Numerator Exponent							Position
Setting range	0 to 17	Unit	---	Default setting	0	Power OFF → ON	---	

Pn4B	Electronic Gear Ratio Denominator							Position
Setting range	1 to 10000	Unit	---	Default setting	2500	Power OFF → ON	---	

- ♦ Set the pulse rate for command pulses and Servomotor travel distance along with Pn46 and Pn47

$$\frac{\text{Electronic Gear Ratio Numerator 1 (Pn46)}}{\text{Electronic Gear Ratio Denominator (Pn4B)}} \times 2^{\text{Electronic Gear Ratio Numerator Exponent (Pn4A)}}$$

or

$$\frac{\text{Electronic Gear Ratio Numerator 2 (Pn47)}}{\text{Electronic Gear Ratio Denominator (Pn4B)}}$$

- ♦ For details, refer to *Electronic Gear* on page 5-9.

Pn4C	Position Command Filter Time Constant Setting							Position
Setting range	0 to 7	Unit	---	Default setting	0	Power OFF → ON	---	

- ♦ Set the time constant for the primary lag filter for command pulse inputs.
- ♦ If the command pulses are erratic, the normal countermeasure is to reduce the stepping movement of the Servomotor.

### Explanation of Settings

Setting	Explanation
0	No filter
1	Time constant: 0.2 ms
2	Time constant: 0.6 ms
3	Time constant: 1.3 ms
4	Time constant: 2.6 ms
5	Time constant: 5.3 ms
6	Time constant: 10.6 ms
7	Time constant: 21.2 ms

Pn4D	Not used. (Do not change setting.)						
------	------------------------------------	--	--	--	--	--	--



Pn4E	Smoothing Filter Setting						Position
Setting range	0 to 31	Unit	---	Default setting	0	Power OFF → ON	Yes

- ◆ Select the FIR filter time constant used for the command pulses (FIR: Finite impulse response).
- ◆ The higher the setting, the smoother the command pulses.

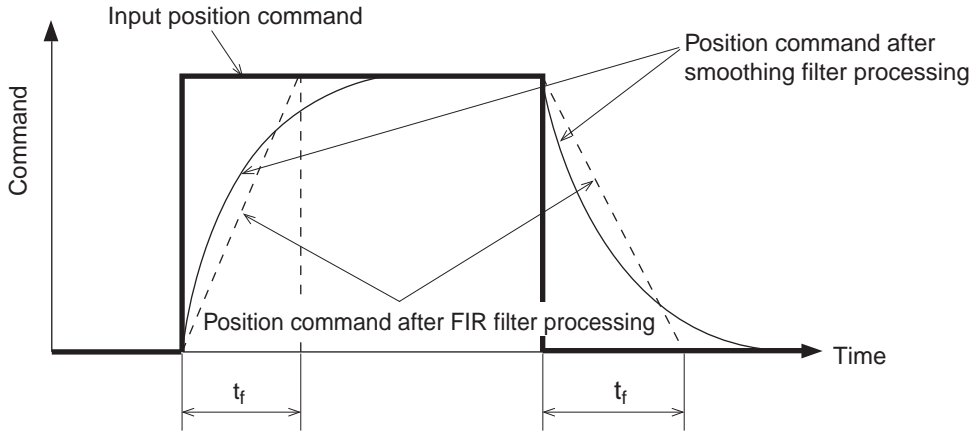

$$t_f = (Pn4E + 1) \times \text{Control cycle}$$

- ◆ Control Cycles with High-response Position Control (Pn02 = 0):
  - Setting: 0, Cycle:  $(0 + 1) \times 166 = 166 \mu\text{s}$
  - Setting: 1, Cycle:  $(1 + 1) \times 166 = 332 \mu\text{s}$
  - Setting: 31, Cycle:  $(31 + 1) \times 166 = 5312 \mu\text{s}$
- ◆ Control Cycles with Advanced Position Control (Pn02 = 2):
  - Setting: 0, Cycle:  $(0 + 1) \times 333 = 333 \mu\text{s}$
  - Setting: 1, Cycle:  $(1 + 1) \times 333 = 666 \mu\text{s}$
  - Setting: 31, Cycle:  $(31 + 1) \times 333 = 10656 \mu\text{s}$

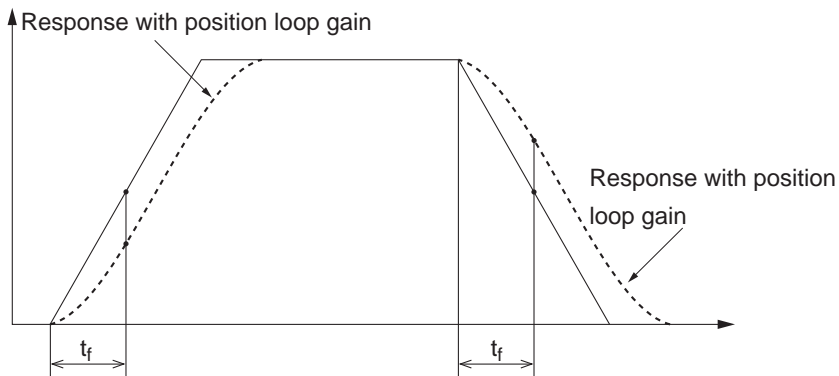

Pn4F	Not used. (Do not change setting.)						
------	------------------------------------	--	--	--	--	--	--

■ Internally Set Speed Control Parameters

Pn50	Not used. (Do not change setting.)						
Pn51	Not used. (Do not change setting.)						
Pn52	Not used. (Do not change setting.)						

Pn53	No. 1 Internally Set Speed					Internally set speed	
Setting range	-20000 to 20000	Unit	r/min	Default setting	100	Power OFF → ON	---

Pn54	No. 2 Internally Set Speed					Internally set speed	
Setting range	-20000 to 20000	Unit	r/min	Default setting	200	Power OFF → ON	---

Pn55	No. 3 Internally Set Speed					Internally set speed	
Setting range	-20000 to 20000	Unit	r/min	Default setting	300	Power OFF → ON	---

Pn56	No. 4 Internally Set Speed					Internally set speed	
Setting range	-20000 to 20000	Unit	r/min	Default setting	400	Power OFF → ON	---

- ◆ These speed settings are used for Internally Set Speed Control.
- ◆ Use internally set speeds No. 1 to No. 4 when Internally Set Speed Control is selected in the Control Mode Selection (Pn02).
- ◆ The sign of the setting indicates the direction of rotation. Settings with a plus sign (normally not indicated) are for the forward direction, and settings with minus sign are for the reverse direction.
- ◆ For details, refer to *Internally Set Speed Control* on page 5-4.

Pn57	Jog Speed					All modes	
Setting range	0 to 500	Unit	r/min	Default setting	200	Power OFF → ON	---

- ◆ Use this parameter to set the speed for jog operation.
- ◆ For details, refer to *Auxiliary Function Mode* on page 6-18.

Pn58	Soft Start Acceleration Time					Internally set speed	
Setting range	0 to 5000	Unit	× 2 ms	Default setting	0	Power OFF → ON	---

Pn59	Soft Start Deceleration Time					Internally set speed	
Setting range	0 to 5000	Unit	× 2 ms	Default setting	0	Power OFF → ON	---

- ◆ Set the acceleration or deceleration time for Internally Set Speed Control.
- ◆ Set the time (setting × 2 ms) required until the Servomotor rotation speed reaches 1,000 r/min or until operation stops from 1,000 r/min.

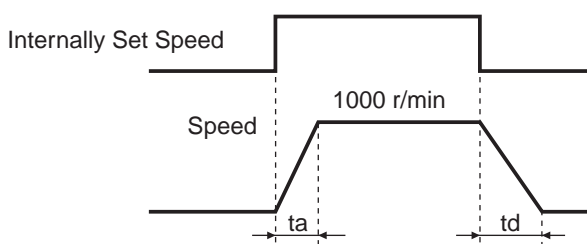

Pn5A	Not used. (Do not change setting.)
Pn5B	Not used. (Do not change setting.)
Pn5C	Not used. (Do not change setting.)
Pn5D	Not used. (Do not change setting.)

Pn5E	Torque Limit					All modes	
Setting range	0 to 500	Unit	%	Default setting	300	Power OFF → ON	---

- ♦ Set the limit for the maximum torque of the Servomotor.
- ♦ Normally, the Servomotor generates an instantaneous torque three times the rated value. Limit the maximum torque, however, if a torque of three times the rated value may cause problems with the strength of the mechanical system.
- ♦ Make the setting as a percentage of the rated torque.  
Example: Maximum torque limited to 150%

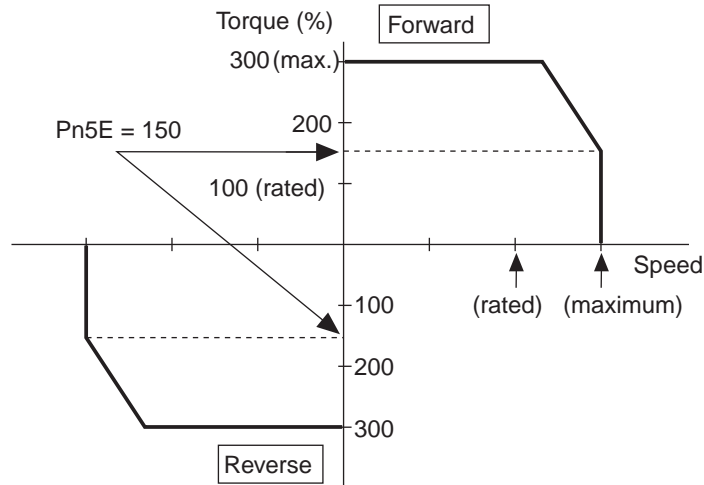

- ♦ Both the forward and the reverse torque are limited at the same time.
- ♦ This parameter will be used for No.1 torque control if the Zero Speed Designation/Torque Limit Switch (Pn06) is set to 2.
- ♦ The default setting depends on the combination of Servomotor and Servo Drive.
- ♦ Values exceeding the default setting cannot be set.
- ♦ Refer to *Torque Limit* on page 5-15.

Pn5F	Not used. (Do not change setting.)
------	------------------------------------

■ Sequence Parameters

Pn60	Positioning Completion Range					Position
Setting range	0 to 32767	Unit	Pulse	Default setting	25	Power OFF → ON ---

- ♦ Set the deviation counter value for the Positioning Completed Output (INP).
- ♦ The Positioning Completed Output (INP) turns ON when the accumulated pulses in the deviation counter fall below the setting of this parameter.

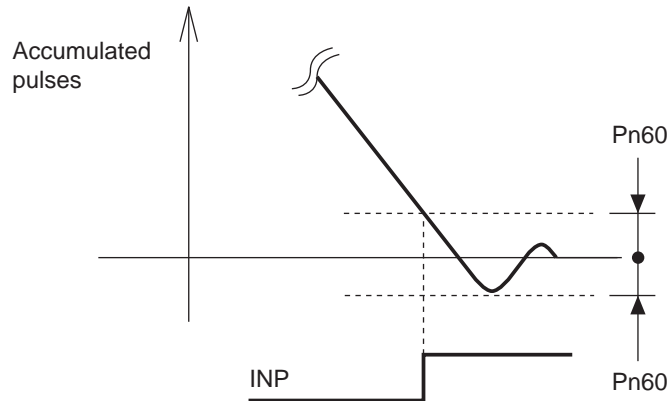

- ♦ The encoder resolution is 2,500 pulses/rotation, but in the Servo Drive it is regarded as 10,000 pulses/rotation (i.e., 2,500 pulses/rotation × 4).

Pn61	Zero Speed Detection					All modes
Setting range	0 to 20000	Unit	r/min	Default setting	20	Power OFF → ON ---

- ♦ Set the number of rotations for the warning output (zero speed detection output).
- ♦ The Warning Output Selection (Pn09) must be set to 1 to output zero speed detection.
- ♦ Zero speed detection will be output if the Servomotor speed falls below the set speed regardless of the direction of rotation.

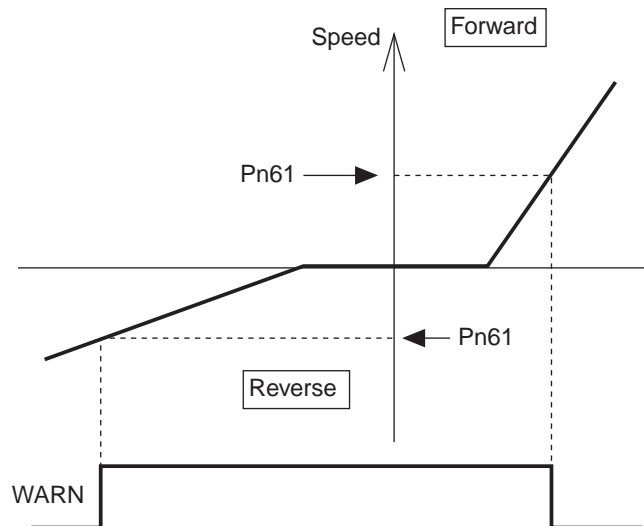

- ♦ There is an hysteresis of 10 r/min, so set a value higher than 10.

Pn62	Rotation Speed for Servomotor Rotation Detection						Internally set speed
Setting range	0 to 20000	Unit	r/min	Default setting	50	Power OFF → ON	---

- ♦ Set the number of rotations for the Servomotor Rotation Speed Detection Output (TGON) during Internally Set Speed Control.
- ♦ The Servomotor Rotation Speed Detection Output (TGON) will turn ON if the Servomotor speed exceeds the set speed regardless of the direction of rotation.

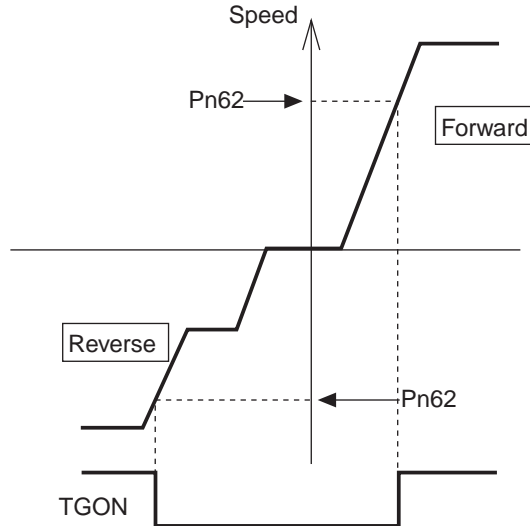

- ♦ There is a hysteresis of 10 r/min, so set a value higher than 10.

Pn63	Deviation Counter Overflow Level						Position
Setting range	0 to 32767	Unit	× 256 pulses	Default setting	100	Power OFF → ON	---

- ♦ Set the detection level for the deviation counter overflow alarm.
- ♦ The alarm level is the setting value multiplied by 256 pulses.

Pn64	Deviation Counter Overflow Alarm Disabled						Position
Setting range	0 or 1	Unit	---	Default setting	0	Power OFF → ON	---

- ♦ The deviation counter overflow alarm can be disabled so that it does not occur.

**Explanation of Settings**

Setting	Explanation
0	Enabled
1	Disabled

Pn65	Not used. (Do not change setting.)						
------	------------------------------------	--	--	--	--	--	--

## 5-10 User Parameters

Pn66	Stop Selection for Drive Prohibit Input						All modes
Setting range	0 to 2	Unit	---	Default setting	0	Power OFF → ON	Yes

- ♦ Set the operation to be used to decelerate to a stop after the Forward Drive Prohibit Input (POT) or Reverse Drive Prohibit Input (NOT) is turned ON.

### Explanation of Settings

Setting	Explanation
0	The torque in the drive prohibit direction is disabled, and the dynamic brake is activated.
1	The torque in the drive prohibit direction is disabled, and free-run deceleration is performed to stop.
2	The servo lock stop is used in a Position Control Mode, and the zero speed designation stop is used in Internally Set Speed Control Mode.

Pn67	Not used. (Do not change setting.)
------	------------------------------------

Pn68	Stop Selection at Alarm						All modes
Setting range	0 to 3	Unit	---	Default setting	0	Power OFF → ON	---

- ♦ Set the operating condition during deceleration and after stopping when an alarm occurs.
- ♦ The deviation counter will be cleared when an alarm occurs.

### Explanation of Settings

Setting	Explanation		
	During deceleration	After stopping	Deviation counter content
0	Dynamic brake	Dynamic brake	Clear
1	Free run	Dynamic brake	Clear
2	Dynamic brake	Servo free	Clear
3	Free run	Servo free	Clear

Pn69	Stop Selection with Servo OFF							All modes
Setting range	0 to 7	Unit	---	Default setting	0	Power OFF → ON	---	

- ◆ Set the operation during deceleration and after stopping as well as the deviation counter status when the RUN Command Input (RUN) turns OFF.

**Explanation of Settings**

Setting	Explanation		
	During deceleration	After stopping	Deviation counter content
0	Dynamic brake	Dynamic brake	Clear
1	Free run	Dynamic brake	Clear
2	Dynamic brake	Servo free	Clear
3	Free run	Servo free	Clear
4	Dynamic brake	Dynamic brake	Hold
5	Free run	Dynamic brake	Hold
6	Dynamic brake	Servo free	Hold
7	Free run	Servo free	Hold

**Reference**

- ◆ Dynamic Brake at Power OFF

By default, the dynamic brake of the Servo Drive will be engaged when the main circuit power is turned OFF. For this reason, it feels slightly heavier to rotate the Servomotor shaft manually than in servo free status. To release the dynamic brake, disconnect the wirings (U, V, W) from the Servomotor. Be sure to reconnect these wirings before restoring the power.

Pn6A	Brake Timing When Stopped							All modes
Setting range	0 to 100	Unit	× 2 ms	Default setting	10	Power OFF → ON	---	

- ◆ When the RUN Command Input is turned OFF while the Servomotor is stopped, the Brake Interlock Signal (BKIR) will turn OFF, and the Servo will turn OFF after the time set for this parameter (setting × 2 ms) elapses.

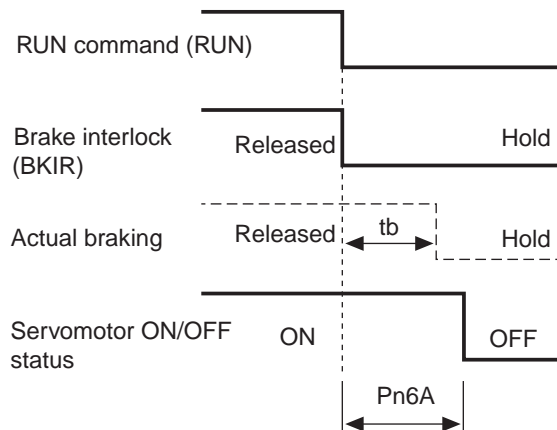

- ◆ Make the setting as follows to prevent the machine (workpiece) from moving or falling due to the delay in the brake operation (tb).

$$\text{Brake timing when stopped (setting} \times 2 \text{ ms)} \geq \text{tb}$$

Pn6B	Brake Timing during Operation						All modes
Setting range	0 to 100	Unit	× 2 ms	Default setting	50	Power OFF → ON	---

♦ When the RUN Command Input is turned OFF while the Servomotor is operating, the Servomotor will decelerate, the number of rotations will drop, and the Brake Interlock Signal (BKIR) will turn OFF after the time set for this parameter has elapsed (setting × 2 ms).

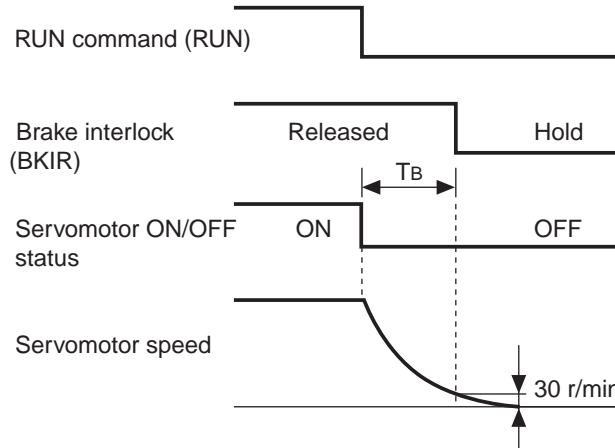

♦ “TB” in the above figure is the brake timing during operation (setting × 2 ms) or the time required until the Servomotor rotation speed falls to 30 r/min or lower, whichever is shorter.

Pn6C	Regeneration Resistor Selection						All modes
Setting range	0 to 3	Unit	---	Default setting	0	Power OFF → ON	---

♦ Set whether to mount an External Regeneration Resistor.

**Explanation of Settings**

Setting	Explanation	
	Regeneration resistor used	Regeneration resistor overload alarm
0	Servo Drive built-in capacitor	The external regeneration processing circuit does not operate. Regenerative energy is processed with the built-in capacitor.
1	External Regeneration Resistor	An External Regeneration Resistor alarm (alarm code 18) will occur when the resistance exceeds 10% of the operating limit.
2	External Regeneration Resistor	The regeneration resistor overload alarm does not operate.
3	Servo Drive built-in capacitor	The external regeneration processing circuit does not operate. Regenerative energy is processed with the built-in capacitor.

**Precautions for Safe Use**

♦ Always install a thermal fuse or other external protection when Pn6C is set to 2. Without protection for the External Regeneration Resistor, it may generate abnormal heat and result in burning.

Pn6D	Not used. (Do not change setting.)
Pn6E	Not used. (Do not change setting.)



Pn6F	Not used. (Do not change setting.)						
------	------------------------------------	--	--	--	--	--	--

Pn70	Overspeed Detection Level Setting						All modes
Setting range	0 to 6000	Unit	r/min	Default setting	0	Power OFF → ON	---

- ♦ Set the No. 1 overspeed detection level when torque limit switching is enabled in the setting of the Zero Speed Designation/Torque Limit Switch (Pn06).
- ♦ When the No. 1 torque limit is selected, an overspeed error will occur if the rotation speed of the Servomotor exceeds the setting.
- ♦ This parameter is disabled when torque limit switching is disabled.

Pn71	No. 2 Torque Limit						All modes
Setting range	0 to 500	Unit	%	Default setting	100	Power OFF → ON	---

- ♦ Set the No. 2 torque limit when torque limit switching is enabled in the setting of the Zero Speed Designation/Torque Limit Switch (Pn06).
- ♦ This parameter is disabled when torque limit switching is disabled.
- ♦ Refer to *Torque Limit* on page 5-54 for information on setting details.

Pn72	No. 2 Deviation Counter Overflow Level						All modes
Setting range	1 to 32767	Unit	× 256 pulse	Default setting	100	Power OFF → ON	---

- ♦ Set the No. 2 deviation counter overflow level when torque limit switching is enabled in the setting of the Zero Speed Designation/Torque Limit Switch (Pn06).
- ♦ This parameter is disabled when torque limit switching is disabled.
- ♦ Refer to *Deviation Counter Overflow Level* on page 5-56 for information on setting details.

Pn73	No. 2 Overspeed Detection Level						All modes
Setting range	0 to 6000	Unit	r/min	Default setting	0	Power OFF → ON	---

- ♦ Set the No. 2 overspeed detection level when torque limit switching is enabled in the setting of the Zero Speed Designation/Torque Limit Switch (Pn06).
- ♦ When No. 2 torque limit is selected, an overspeed error will occur if the rotation speed of the Servomotor exceeds the setting.
- ♦ This parameter is disabled when torque limit switching is disabled.

Pn74	Not used. (Do not change setting.)						
------	------------------------------------	--	--	--	--	--	--

to

Pn7F	Not used. (Do not change setting.)						
------	------------------------------------	--	--	--	--	--	--



# Chapter 6

## Operation

<b>6-1</b>	<b>Operational Procedure .....</b>	<b>6-1</b>
<b>6-2</b>	<b>Preparing for Operation.....</b>	<b>6-2</b>
	Items to Check Before Turning ON the Power.....	6-2
	Turning ON Power .....	6-2
	Checking Displays .....	6-3
<b>6-3</b>	<b>Using the Parameter Unit .....</b>	<b>6-4</b>
	Names of Parts and Functions.....	6-4
	Display When Power Is Turned ON .....	6-5
	Changing the Mode.....	6-6
	Monitor Mode .....	6-7
	Parameter Setting Mode .....	6-15
	Parameter Write Mode.....	6-16
	Autotuning Mode.....	6-17
	Auxiliary Function Mode.....	6-18
	Copy Mode.....	6-20
<b>6-4</b>	<b>Trial Operation.....</b>	<b>6-23</b>
	Preparation for Trial Operation .....	6-23
	Trial Operation .....	6-23

# 6-1 Operational Procedure

After installation and wiring, turn ON the power and check the operation of the Servomotor and Servo Drive. Then make the function settings as required according to the use of the Servomotor and Servo Drive. If the parameters are set incorrectly, there is a danger of the Servomotor operating in an unpredictable manner. Set the parameters according to the instructions in this manual.

Item	Contents	Reference
Mounting and installation	Install the Servomotor and Servo Drive according to the installation conditions. (Do not connect the Servomotor to the mechanical system before checking the no-load operation.)	Chapter 4 Page 4-1
↓		
Wiring and connections	Connect the Servomotor and Servo Drive to the power supply and peripheral devices. * Specified installation and wiring requirements must be satisfied, particularly for models conforming to the EC Directives.	Chapter 4 Page 4-9
↓		
Preparing for operation	Check the necessary items and then turn ON the power supply. Check with the display indications to see whether there are any internal errors in the Servo Drive.	Chapter 6 Page 6-2
↓		
Checking operation	Check the operation of the Servomotor and Servo Drive by performing jogging operations without a load.	Chapter 6 Page 6-4
↓		
Setting functions	Set the functions according to the operating conditions with the user parameters.	Chapter 5 Page 5-17
↓		
Trial operation	To enable the parameter settings, turn OFF the power first. Connect the Servomotor to the mechanical system. Turn ON the power, and check to see whether protective functions, such as the emergency stop and operational limits, work properly. Check operation without a workpiece, or with dummy workpieces at low and high speed. (Operate using commands from a position controller.)	Chapter 6 Page 6-23
↓		
Adjustments	Manually adjust the gain if necessary. Further adjust the various functions to improve the control performance.	Chapter 7
↓		
Operation	Operation can now be started. If any problems should occur, refer to <i>Chapter 8 Troubleshooting</i> .	Chapter 8

---

## 6-2 Preparing for Operation

---

This section explains the procedure to prepare the mechanical system for trial operation after the installation and wiring of the Servomotor and Servo Drive are completed. It also explains the items that need to be checked before and after turning ON the power.

### Items to Check Before Turning ON the Power

#### ■ Checking Power Supply Voltage

- ♦ Check to be sure that the power supply voltage is within the ranges shown below.
  - R7D-BP□□L (Single-phase 100 VAC input)  
Main-circuit power supply: Single-phase 100/115 VAC (85 to 127 V) 50/60 Hz
  - R7D-BP□□H (Single-phase/three-phase 200 VAC input)  
Main-circuit power supply: Single-phase/three-phase 200/240 VAC (170 to 264 V) 50/60 Hz
  - R7D-BP□□HH (Single-phase 200 VAC input)  
Main-circuit power supply: Single-phase 200/240 VAC (170 to 264 V) 50/60 Hz

#### ■ Checking Terminal Block Wiring

- ♦ The main-circuit power supply input lines (L1/L3 or L1/L2/L3) must be properly connected to the terminal block.
- ♦ The Servomotor's red (U), white (V), and blue (W) power lines and the green/yellow ground wire (⊕) must be properly connected to the terminal block.

#### ■ Checking the Servomotor

- ♦ There should be no load on the Servomotor. (Do not connect the mechanical system.)
- ♦ The Servomotor's power lines and the power cables are securely connected.
- ♦ The Encoder Cable must be securely connected to the Encoder Connector (CN2) at the Servo Drive.
- ♦ The Encoder Cable must be securely connected to the Encoder Connector at the Servomotor.

#### ■ Checking the I/O Control Connectors

- ♦ The Control Cable must be securely connected to the I/O Control Connector (CN1).
- ♦ The RUN Command Input (RUN) must be OFF.

#### ■ Checking Parameter Unit Connections

- ♦ The Parameter Unit (R88A-PR02G) must be securely connected to the CN3 connector.

### Turning ON Power

- ♦ After checking the above items, turn ON the main circuit power supply.
- ♦ The alarm output (ALM) will take approximately 2 seconds to turn ON after the power has been turned ON. Do not attempt to detect an alarm using the Host Controller during this time (when power is being supplied with the Host Controller connected).

### Checking Displays

- ♦ After turning ON the power, confirm that the Servo Drive's power supply LED indicator (PWR) is lit green.
- ♦ When the power is turned ON, one of the following will appear on the Parameter Unit display.

Normal	Error (alarm display)
r 0	Err. 14

If Servo Drive is normal, the item set for Default Display (Pn01) will appear on the display.

If there is an error, an alarm code will appear. The number shown (an alarm code) depends on the cause of the error.

## 6-3 Using the Parameter Unit

This section describes the basic operation of the Parameter Unit, the jog operation with just the Servomotor and Servo Drive, and the Parameter Unit's copy function.

### Names of Parts and Functions

#### ■ Parameter Unit Names

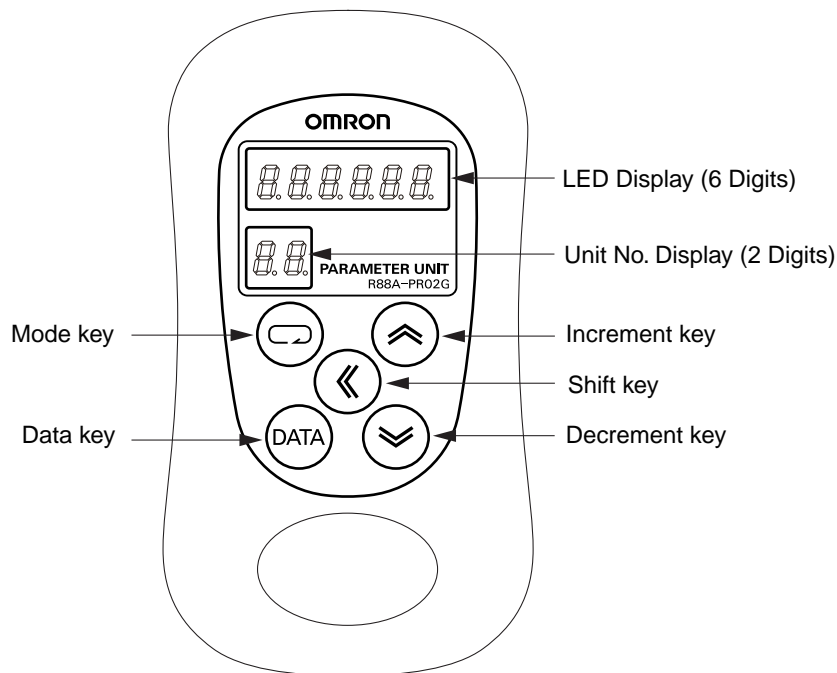

#### ■ Parameter Unit Functions

Name	Function
LED Display	Displays the parameters and data settings.
Unit No. Display	Displays the Unit No. set in Unit No. Setting (Pn00). Displays the parameter number in Parameter Setting Mode.
Mode key	Switches among the six modes.
Data key	Switches between the parameter and setting displays, saves data settings.
Increment key	Increases the parameter number or set value.
Decrement key	Decreases the parameter number or set value.
Shift key	Shifts the digit to the left.

### Display When Power Is Turned ON

Turn ON the power with the Parameter Unit connected to the Servo Drive, or connect the Parameter Unit to the Servo Drive with Servo Drive power already turned ON. Then the following indications appear on the display.

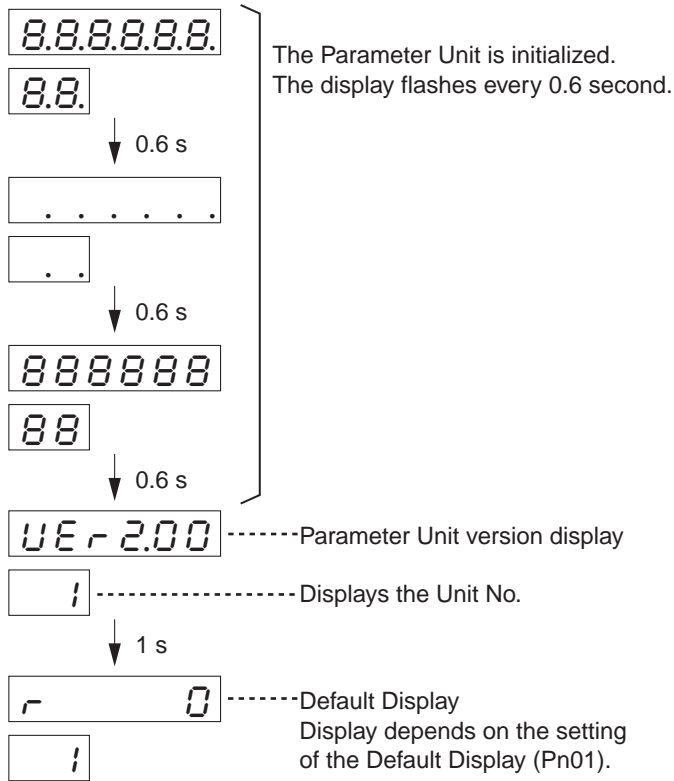



### Changing the Mode

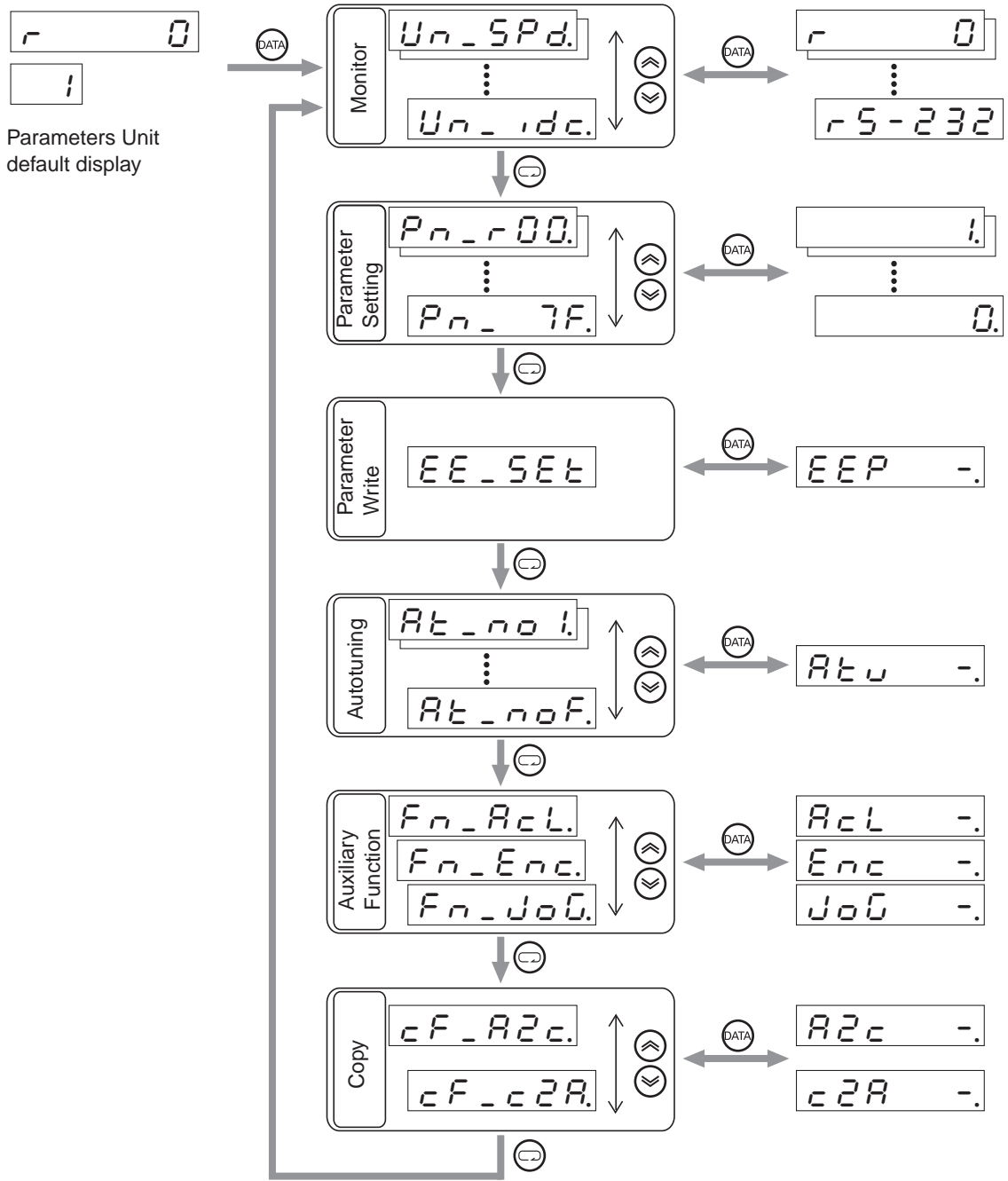

## Monitor Mode

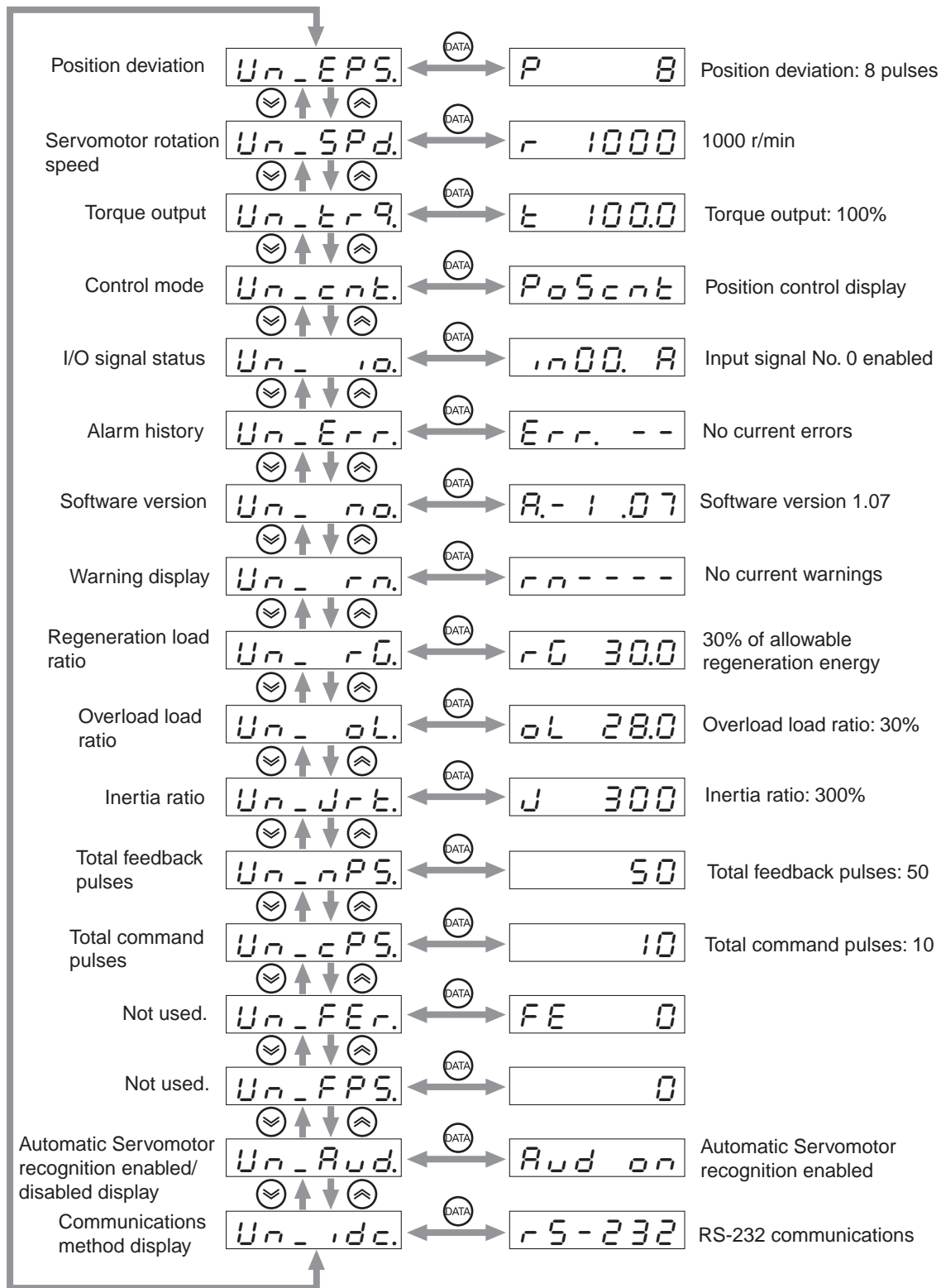

- ♦ The Servomotor rotation speed will be displayed the first time the power is turned ON after purchase. To change the initial display when the power is turned ON, change the setting of the Default Display (Pn01). For details, refer to the description of the Default Display (Pn01) on page 5-32.

### ■ Position Deviation

P 8

- ◆ Displays the number of accumulated pulses in the deviation counter (unit: pulse).
- ◆ Accumulated pulses during reverse rotation are displayed with "-".

### ■ Servomotor Rotation Speed

r 1000

- ◆ Displays the Servomotor rotation speed (unit: r/min).
- ◆ Rotation speeds during reverse rotation are displayed with "-".

### ■ Torque Output

t 100.0

- ◆ Displays the percentage of Servomotor torque output.
- ◆ When the rated torque output for the Servomotor is used, "100%" is displayed.
- ◆ Torque outputs during reverse rotation are displayed with "-".

### ■ Control Mode

Poscnt Position Control Mode

SPdcnt Internally Set Speed Control Mode

- ◆ Displays whether the position control or internally set speed control is being used.
- ◆ The High-response Position Control Mode and Advanced Position Control Mode are displayed as Position Control Modes.

### ■ I/O Signal Status

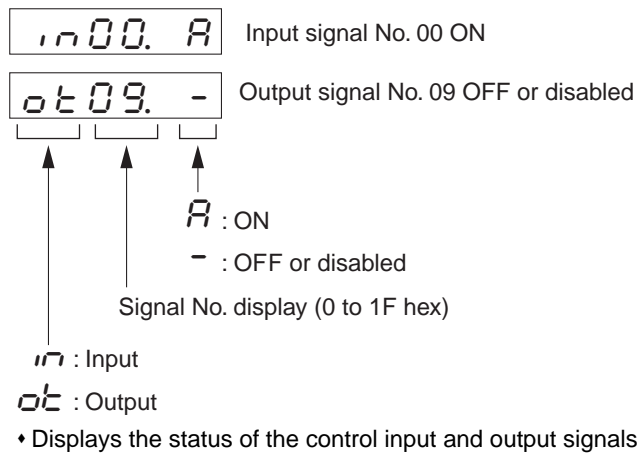

## Input Signals

CN1				Function
Signal No.	Symbol	Name	Pin No.	
00	RUN	RUN Command	2	If the RUN signal turns ON, a Servo lock occurs, and $\bar{H}$ is displayed.
01	RESET	Alarm Reset	3	If the RESET signal turns ON, the alarm is reset, and $\bar{H}$ is displayed.
02	NOT	Reverse Drive Prohibit	7	If the Drive Prohibit Input Selection (Pn04) is set to disable the prohibit inputs (setting 1), “-” is displayed. If Pn04 is set to enable the prohibit inputs (setting 0), the Servomotor stops and $\bar{H}$ is displayed when the POT signal turns OFF.
03	POT	Forward Drive Prohibit	8	
04	Not used.			
05	VZERO	Zero Speed Designation	5	The Servomotor stops and $\bar{H}$ is displayed if this signal turns OFF when the Zero Speed Designation/Torque Limit Switch (Pn06) is set to 1.
06	GESEL	Electronic Gear Switch	6	If the GESEL signal turns ON, the Electronic Gear Ratio Numerator 2 is enabled, and $\bar{H}$ is displayed.
07 to 08	Not used.			
09	GSEL	Gain Switch	5	When the Gain Switching Input Operating Mode Selection (Pn30) is set to 0 and the GSEL signal turns OFF, PI operation is enabled and “-” is displayed.
0A	ECRST	Deviation Counter Reset	4	Used to reset the deviation counter. When the ECRST signal turns ON, $\bar{H}$ is displayed.
0B	Not used.			
0C	VSEL1	Internally Set Speed Selection 1	6	When VSEL1 and VSEL2 are ON, $\bar{H}$ is displayed.
0D	VSEL2	Internally Set Speed Selection 2	4	
0E to 1F	Not used.			

Output Signals

CN1				Function
Signal No.	Symbol	Name	Pin No.	
00	Not used.			
01	/ALM	Alarm	9	If an alarm occurs, the /ALM signal turns OFF, and $\bar{H}$ is displayed.
02	INP	Positioning Completed	10	When a workpiece is positioned within the setting range, the Positioning Completion Range (Pn60), INP turns ON and $\bar{H}$ is displayed.
03	BKIR	Brake Interlock	11	The output transistor for the electromagnetic brake signal turns ON, and $\bar{H}$ is displayed.
04	---	Zero Speed Detection	12	When the Warning Output Selection (Pn09) is set to 1, and Zero Speed Detection output turns ON, $\bar{H}$ is displayed.
05	---	Torque Limiting	12	When the Warning Output Selection (Pn09) is set to 0, and Torque Limiting output turns ON, $\bar{H}$ is displayed.
06 to 08	Not used.			
09	TGON	Servomotor Rotation Speed Detection	10	When the actual motor speed exceeds the Rotation Speed for Servomotor Rotation Detection (Pn62), TGON turns ON and $\bar{H}$ is displayed.
0A to 1F	Not used.			

Switching between Input Signals and Output Signals

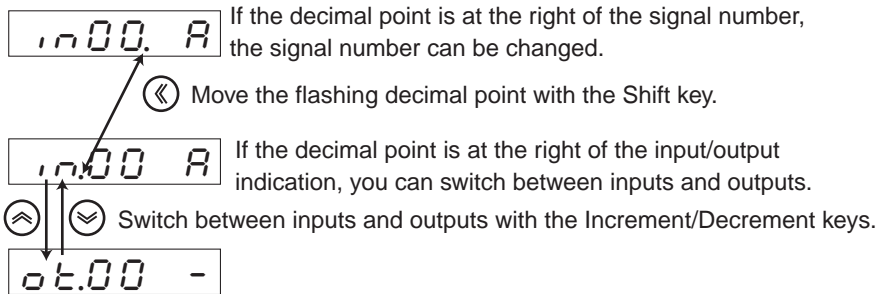

The following procedure can also be used to switch between input and output.

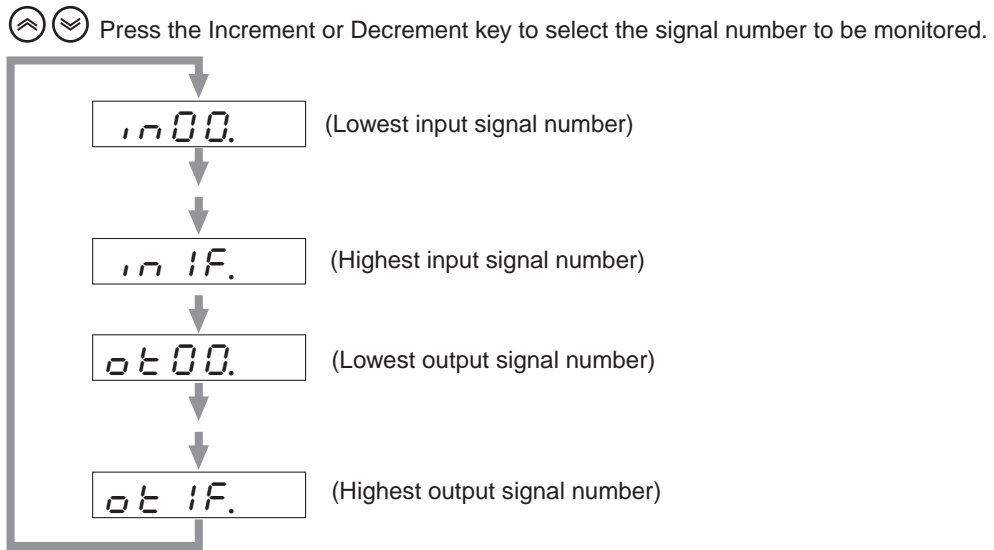

■ Alarm History

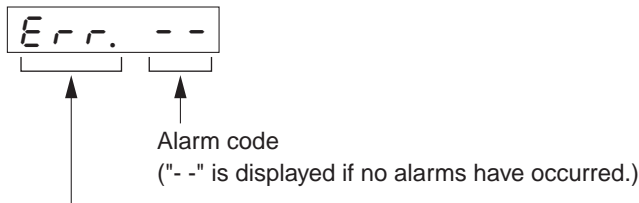

- Err. : Current alarm
- E - 0. : Alarm 0 (newest alarm)
- E 13. : Alarm 13 (oldest alarm)

- ♦ Up to 14 alarms, including the current one, can be viewed in the alarm history.
- ♦ The display will flash when an alarm occurs.
- ♦ If an alarm that is recorded in the history occurs, the alarm code for the current alarm and for alarm 0 will be the same.

**Alarm Codes and Meanings**

Alarm codes	Meaning
11	Power supply undervoltage
12	Overvoltage
14	Overcurrent
15	Built-in resistor overheat
16	Overload
18	Regeneration overload
21	Encoder disconnection detection
23	Encoder data error
24	Deviation counter overflow
26	Overspeed
27	Electronic gear setting error

Alarm codes	Meaning
29	Deviation counter overflow
34	Overrun limit error
36	Parameter error
37	Parameter corruption
38	Drive prohibit input error
48	Encoder phase Z error
49	Encoder CS signal error
95	Servomotor non-conformity
96	LSI setting error
Others	Other errors

**Note** The following alarms are not recorded in the history.  
 11: Power supply undervoltage  
 36: Parameter error  
 37: Parameter corruption  
 38: Drive prohibit input error  
 95: Servomotor non-conformity  
 96: LSI setting error

**■ Software Version**

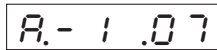

◆ Displays the software version of the Servo Drive.

**■ Warning Display**

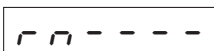

- : No warning, **A** : Warning

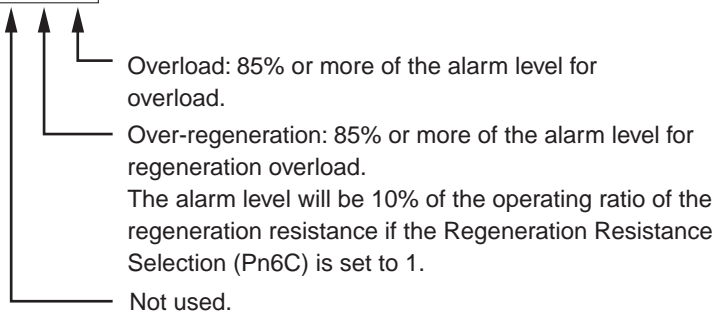

**■ Regeneration Load Ratio**



◆ Displays the load ratio as a percentage of the detection level for the regeneration load.



■ **Overload Load Ratio**

`oL 28.0`

- ◆ Displays the percentage of the load ratio as a percentage of the rated load.

■ **Inertia Ratio**

`J 100`

Displays the inertia ratio as a percentage.

■ **Total Feedback Pulses/Total Command Pulses**

`100`

- ◆ Displays the total number of pulses after the power supply is turned ON.
- ◆ The display will overflow as shown in the following figure.

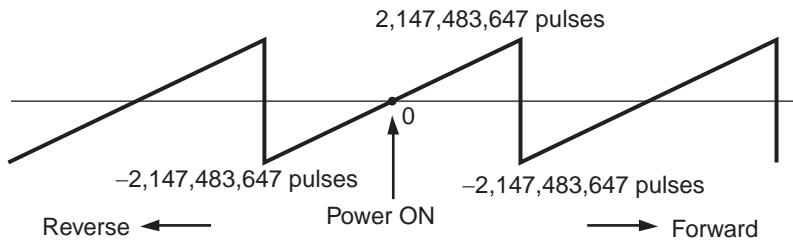

- ◆ Use the Shift key to switch the display between the upper and lower digits of the total number of pulses.



- ◆ When the Data key is pressed for 5 s or longer, the total number of pulses will be reset, and the display will return to 0.

■ **Automatic Servomotor Recognition**

`Rud on`

Automatic recognition enabled (Always this indication is displayed)

## Parameter Setting Mode

### 1. Displaying Parameter Setting Mode

Key operation	Display example	Explanation
		The item set for the Default Display (Pn01) is displayed.
		Press the Data key to display Monitor Mode.
		Press the Mode key to display Parameter Setting Mode.

### 2. Setting the Parameter Number

Key operation	Display example	Explanation
		Use the Shift, Increment, and Decrement keys to set the parameter number. If the parameter number is large, the setting can be made more quickly by using the Shift key to change the digit that is being set. The decimal point will flash for the digit that can be set.

### 3. Displaying the Parameter Setting

Key operation	Display example	Explanation
		Press the Data key to display the setting.

### 4. Changing the Parameter Setting

Key operation	Display example	Explanation
		Use the Shift, Increment, and Decrement keys to change the setting. The decimal point will flash for the digit that can be changed.
		Press the Data key to save the new setting.

### 5. Returning to the Display of Parameter Setting Mode

Key operation	Display example	Explanation
		Press the Data key to return to the Parameter Setting Mode Display.







#### Precautions for Correct Use

- ♦ Some parameters will be displayed with an "r" before the number when the Parameter Setting Mode is displayed. To enable the settings that have been changed for these parameters, you must turn the power supply OFF and ON after saving the parameters in EEPROM.
- ♦ Once the setting for a parameter is saved, the new setting will be used for control. Make changes little by little, not widely when setting the parameters (in particular, the speed loop gain, position loop gain, etc.) which can affect the motor operation greatly.
- ♦ For details on parameters, refer to *Parameter Details* on page 5-32.

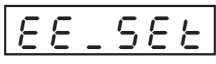
## Parameter Write Mode

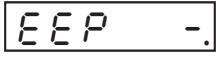
Settings changed in the Parameter Setting Mode must be saved in EEPROM. To do so, the following procedure must be performed.

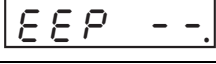
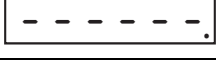
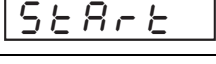
### 1. Saving Changed Settings

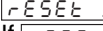
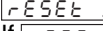
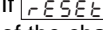
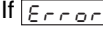
Key operation	Display example	Explanation
		Press the Mode key to display Parameter Write Mode.
		Press the Data key to enter Parameter Write Mode.
		Press and hold the Increment key for at least 5 s.
		The bar indicator will increase.
		Writing will start. (This display will appear only momentarily.)
		This display indicates a normal completion. In addition to "Finish," either  or  may be displayed. If  is displayed, writing has been completed normally, but some of the changed parameters will be enabled only after the power is turned ON again. Turn OFF the Servo Drive power supply and then turn it ON again. If  is displayed, there is a writing error. Write the data again.

### 2. Returning to the Display of Parameter Write Mode

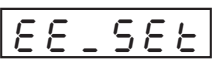
Key operation	Display example	Explanation
		Press the Data key to return to the Parameter Write Mode Display.





#### Precautions for Correct Use

- If a writing error occurs, write the data again. If a writing error continues to occur, there may be a fault in the Servo Drive.
- Do not turn OFF the power supply while writing in EEPROM. Incorrect data may be written if the power supply is turned OFF. If the power supply is turned OFF, perform the settings again for all parameters, and write the data again.
- Do not disconnect the Parameter Unit from the Servo Drive during the time from writing start ("Start") to writing completion ("Finish" or "Reset"). If the Parameter Unit is disconnected, repeat the procedure from the beginning.



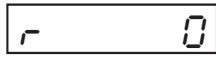

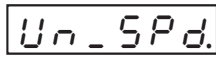
## Autotuning Mode

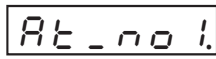
For details on autotuning, refer to 7-3 *Autotuning*. This section describes only the operating procedure.

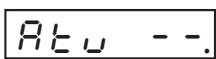
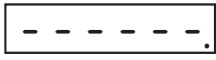
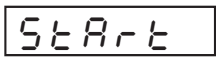
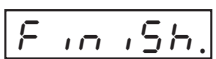

### 1. Displaying Autotuning Mode

Key operation	Display example	Explanation
		The item set for the Default Display (Pn01) is displayed.
		Press the Data key to display Monitor Mode.
		Press the Mode key three times to display Autotuning Mode.

### 2. Executing Autotuning

Key operation	Display example	Explanation
		Press the Data key to enter Autotuning Mode.
		Press and hold the Increment key until "Start" is displayed. The bar indicator will increase when the key is pressed for 5 s or longer.
		The bar indicator will increase.
		The Servomotor will start, and autotuning will begin.
		This display indicates a normal completion. If  is displayed, a tuning error has occurred.

### 3. Returning to the Display of Autotuning Mode

Key operation	Display example	Explanation
		Press the Data key to return to the Autotuning Mode Display.

#### Precautions for Correct Use

- ◆ Do not remove the Parameter Unit from the Servo Drive during the time from Start to Finish. If the Parameter Unit is removed during autotuning, repeat the procedure from the beginning.
- ◆ Always save each gain value changed with autotuning in EEPROM so that the data is not lost when the power is turned OFF.
- ◆ If an autotuning error occurs, the values for each gain will return to the value before executing autotuning.

## Auxiliary Function Mode

The Auxiliary Function Mode includes the alarm reset and jog operation.

### Displaying Auxiliary Function Mode

Key operation	Display example	Explanation
		The items set for the Default Display (Pn01) is displayed.
		Press the Data key to display Monitor Mode.
		Press the Mode key four times to display Auxiliary Function Mode.

## ■ Alarm Reset

### 1. Executing Alarm Reset





Key operation	Display example	Explanation
		Press the Data key to enter Alarm Reset Mode.
		Press and hold the Increment key until "Start" is displayed. The bar indicator will increase when the key is pressed for 5 s or longer.
		The bar indicator will increase.
		Alarm reset will start.
		This display indicates a normal completion. If  is displayed, an alarm has not been reset. Reset the power supply to clear the error.

### 2. Returning to the Display of Auxiliary Function Mode

Key operation	Display example	Explanation
		Press the Data key to return to the Auxiliary Function Mode Display.

■ Jog Operation

1. Executing Jog Operation

Key operation	Display example	Explanation
	<code>Fn_JoG.</code>	Press the Increment key to display the Jog Operation Mode on the alarm reset display in Auxiliary Function Mode.
	<code>JoG -.</code>	Press the Data key to enter Jog Operation Mode.
	<code>JoG --.</code>	Press and hold the Increment key until "Ready" is displayed. The bar indicator will increase when the key is pressed for 5 s or longer.
	<code>-----.</code>	The bar indicator will increase.
	<code>rEAdY.</code>	This completes preparations for jog operation.
	<code>rEAdY.</code>	Press and hold the Shift key until "Sev_on" is displayed. The decimal point will move to the left when the key is pressed for 3 s or longer.
	<code>r.EAdY</code>	
	<code>SrV_on</code>	The Servo will turn ON.
	<code>SrV_on</code>	Forward operation will be performed while the Increment key is pressed, and reverse operation will be performed while the Decrement key is pressed. The Servomotor will stop when the key is released. The rotation speed set for Jog Speed (Pn57) will be used for jogging.

2. Returning to the Display of Auxiliary Function Mode

Key operation	Display example	Explanation
	<code>Fn_JoG.</code>	Press the Data key to return to the Auxiliary Function Mode Display. The servo lock is released. The system is now in servo free status.

## Copy Mode

In Copy Mode, user parameters set in the Servo Drive can be copied to the Parameter Unit, and user parameters stored in the Parameter Unit can be copied to the Servo Drive. This function can be used to easily set the same user parameters for more than one Servo Drive.

### ■ Copying from the Servo Drive to the Parameter Unit

#### 1. Displaying Copy Mode

Key operation	Display example	Explanation
		The item set for the Default Display (Pn01) is displayed.
		Press the Data key to display Monitor Mode.
		Press the Mode key five times to display Copy Mode.

#### 2. Executing Copying

Key operation	Display example	Explanation
		Press the Data key to enter Copy Mode.
		Press and hold the Increment key until "EEPCLR" is displayed. The bar indicator will increase when the key is pressed for 3 s or longer.
		The bar indicator will increase.
		Initialization of the EEPROM in the Parameter Unit will start.
		This display indicates a normal completion.

#### 3. Returning to the Display of Copy Mode

Key operation	Display example	Explanation
		Press the Data key to return to the Copy Mode Display.

#### Precautions for Correct Use

- ♦ If "Error" is displayed before completion, repeat the procedure from the beginning. Press the Data key to clear the error.
- ♦ Do not disconnect the Parameter Unit from the Servo Drive while copying is being performed. If the Parameter Unit is disconnected, reconnect it and repeat the procedure from the beginning.
- ♦ If an error is repeatedly displayed, the following are the possible causes: cable disconnection, connector contact failure, incorrect operation due to noise, or EEPROM fault in the Parameter Unit.

■ Copying from the Parameter Unit to the Servo Drive

1. Displaying Copy Mode

Key operation	Display example	Explanation
		The item set for the Default Display (Pn01) is displayed.
		Press the Data key to display Monitor Mode.
		Press the Mode key five times to display Copy Mode.
		Press the Increment key to switch to the copy display for copying from the Parameter Unit to the Servo Drive.

2. Checking the Servo Drive Model Code

Key operation	Display example	Explanation
		Press the Data key to enter Copy Mode.
		Press and hold the Increment key until "EEP_CH" is displayed. "DIFFER" will be displayed if a different model code is entered. The bar indicator will increase when the key is pressed for 3 s or longer.
		The bar indicator will increase. The Servo Drive model code is being checked. If a different model code has been entered, refer to 3. <i>Different Model Codes</i> below to perform the procedure. If the model codes match, the display will proceed to the display in 4. <i>Executing Copying</i> .

3. Different Model Codes



Key operation	Display example	Explanation
		The decimal point will move to the left when the Shift key is pressed for 3 s or longer.
		The model codes are being matched. Press the Data key to cancel copying before completion.

4. Executing Copying

Key operation	Display example	Explanation
		Writing user parameters in EEPROM of the Servo Drive will start.
		This display indicates a normal completion.



### 5. Returning to the Display of Copy Mode

Key operation	Display example	Explanation
		Press the Data key to return to the Copy Mode Display.

#### Precautions for Correct Use

- ♦ If "Error" is displayed before completion, repeat the procedure from the beginning.
- ♦ Press the Data key to clear the error.
- ♦ If an error is repeatedly displayed, the following are the possible causes: cable disconnection, connector contact failure, incorrect operation due to noise, or EEPROM fault in the Parameter Unit.
- ♦ Do not disconnect the Parameter Unit from the Servo Drive while copying is being performed.  
If the Parameter Unit is disconnected, incorrect data may be written and the data may be corrupted. Copy the user parameters again from the source Servo Drive to the Parameter Unit, and then copy the user parameters from the Parameter Unit to the other Servo Drive.

## 6-4 Trial Operation

When you have finished installation, wiring, Servomotor/Servo Drive jog operation, and user parameter setting, perform trial operation.

The main purpose of trial operation is to confirm that the servo system operates electrically correctly. Make sure that the host position controller and all peripheral devices are connected, and turn ON the power. Then perform trial operation at low speed to confirm the operation. Next, perform actual run patterns to confirm that the system works properly.

### Precautions for Correct Use

- ♦ If an error occurs during the trial operation, refer to *Chapter 8 Troubleshooting* to eliminate the cause. Then ensure safety and resume operation.
- ♦ If the machine vibrates when starting or stopping, refer to *Chapter 7 Adjustment Functions* and perform the gain adjustment first.

## Preparation for Trial Operation

### ■ Turning OFF the Power

Some parameters are enabled by turning OFF the power and turning it ON again. First turn OFF the main circuit power.

### ■ Preparing for Turning OFF the Servomotor

In order that the Servomotor can be immediately turned OFF if an abnormality occurs in the machine, set up the system so that the power and the RUN Command Input can be turned OFF.

## Trial Operation

### 1. Operating without a Load

- ♦ Turn ON the power to the main circuit and peripheral devices, and then turn ON the RUN Command Input.
- ♦ Check that the Servomotor is in Servo ON status.
- ♦ Send the command to start the Servomotor from the host position controller, and check that the Servomotor operates properly according to the command. (Check that the Servomotor is rotating in the correct direction and the rotation speed and amount of rotation are as specified by the command.)

### 2. Mechanical System Connection

- ♦ Turn OFF the power.
- ♦ Firmly connect the Servomotor shaft to the load (i.e., the mechanical system). Tighten screws and make sure they are not loose.
- ♦ Turn ON the power.

### 3. Low-speed Operation with Actual Load Connected

- ♦ Send a low speed command from the host position controller to start the Servomotor. (The definition of "low speed" depends on the mechanical system, but a rough estimate is 1/10 to 1/5 of normal operating speed.)
- ♦ Check the following items.
  - a) Are the emergency stop and over load switch operating correctly?
  - b) Is the operating direction of the machine correct?

- c) Are the operating sequences correct?
- d) Are there any abnormal sounds or vibration?  
If vibration occurs when starting or stopping the machine, refer to *Chapter 7 Adjustment Functions*, and adjust the gain.
- e) Is any error (or alarm) generated?  
If anything abnormal occurs, refer to *Chapter 8 Troubleshooting* and take the appropriate countermeasures.

#### 4. Regular Pattern Operation

- ♦ Operate the Servomotor in a regular pattern and check the following items.
  - a) Is the operating speed correct?
  - b) Is the load torque almost equivalent to the measured value?
  - c) Are the positioning points correct?
  - d) When an operation is repeated, is there any discrepancy in positioning?
  - e) Are there any abnormal sounds or vibration?  
If vibration occurs when starting or stopping the machine, refer to *Chapter 7 Adjustment Functions*, and adjust the gain.
  - f) Is the Servomotor or the Servo Drive abnormally overheating?
  - g) Is any error (or alarm) generated?  
If anything abnormal occurs, refer to *Chapter 8 Troubleshooting* and take the appropriate countermeasures.

#### 5. Trial Operation Completed

Performing the above completes the trial operation. Next, adjust the gain to improve control performance.



# Chapter 7

## Adjustment Functions

<b>7-1</b>	<b>Gain Adjustment .....</b>	<b>7-1</b>
	Purpose of the Gain Adjustment .....	7-1
	Gain Adjustment Methods.....	7-1
	Gain Adjustment Procedure .....	7-2
<b>7-2</b>	<b>Realtime Autotuning .....</b>	<b>7-3</b>
	Realtime Autotuning Setting Method .....	7-3
	Operating Procedures.....	7-4
	Adaptive Filter .....	7-5
	Automatically Set Parameters.....	7-6
<b>7-3</b>	<b>Autotuning .....</b>	<b>7-8</b>
	Autotuning Setting Method.....	7-8
	Automatically Set Parameters.....	7-11
<b>7-4</b>	<b>Disabling the Automatic Gain Adjustment Function .....</b>	<b>7-13</b>
	Disabling Realtime Autotuning.....	7-13
	Disabling the Adaptive Filter .....	7-14
<b>7-5</b>	<b>Manual Tuning.....</b>	<b>7-15</b>
	Function Differences in Control Modes.....	7-15
	Basic Adjustment Procedures.....	7-16
	Gain Switching Function .....	7-19
	Machine Resonance Control.....	7-21
	Damping Control .....	7-23

# 7-1 Gain Adjustment

SMARTSTEP 2-Series Servo Drive has realtime autotuning and autotuning functions. With these functions, gain adjustments can be made easily even by those who use a servo system for the first time. If autotuning cannot be used, use manual tuning.

## Purpose of the Gain Adjustment

The Servomotor must operate in response to commands from the Servo Drive with minimal time delay and maximum reliability. The gain is adjusted to make the Servomotor operation follow the commands as strictly as possible to the operations specified by the commands, and to maximize the performance of the mechanical system.

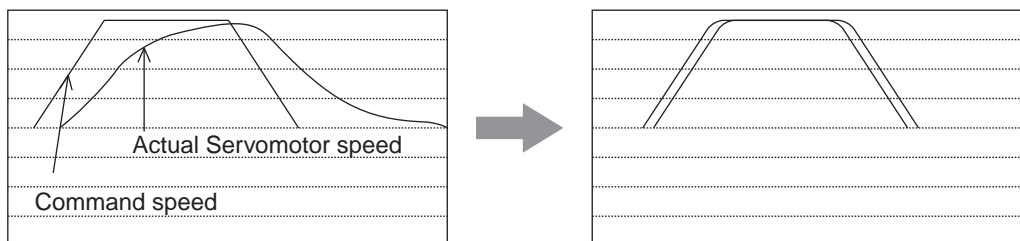

## Gain Adjustment Methods

The SMARTSTEP 2-Series Servo Drive has three gain adjustment methods: realtime autotuning, autotuning, and manual tuning.

### ■ Realtime Autotuning

- ◆ Realtime autotuning estimates the load inertia of the mechanical system in realtime, and automatically sets the optimal gain according to the estimated result.
- ◆ Realtime autotuning includes the adaptive filter function that estimates the resonance frequency from the vibrating component in the motor speed, and automatically sets the notch filter coefficient to suppress the resonance point vibration.

### ■ Autotuning

- ◆ Autotuning operates the Servomotor according to the operating pattern set in the Autotuning Operation Setting (Pn25), estimates the load inertia through the torque required, and automatically sets the optimal gain.

### ■ Manual Tuning

- ◆ Use manual tuning when autotuning cannot be performed due to the restrictions of the operating pattern or load conditions, or when maximum responsiveness needs to be obtained for individual loads.

The default setting is for manual tuning.

## Gain Adjustment Procedure

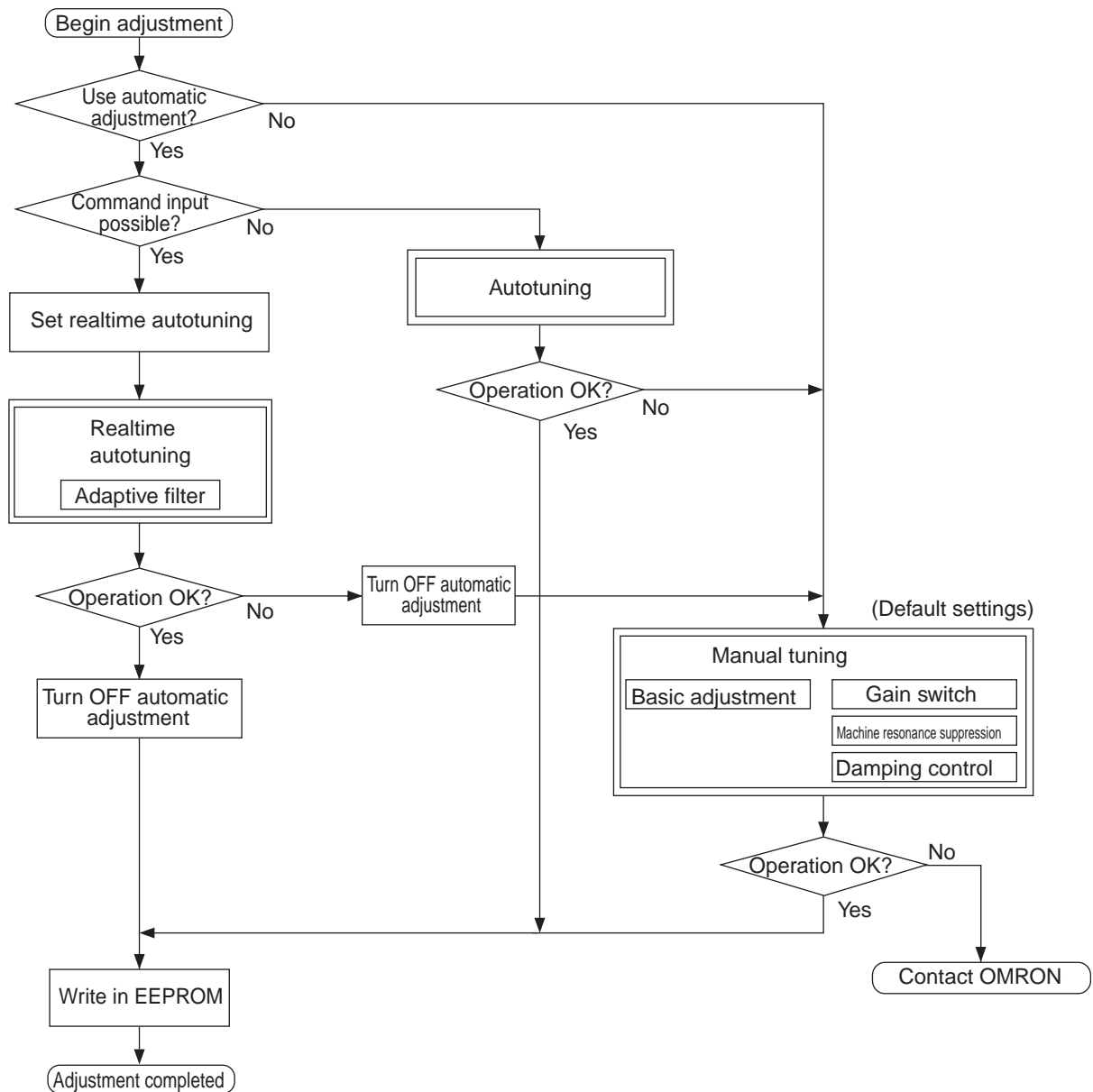

### Reference Gain Adjustment and Machine Rigidity

- ♦ The specific vibration (resonance frequency) of the mechanical system has a large impact on the gain adjustment. The servo system responsiveness cannot be set high for machines with a low resonance frequency (low machine rigidity).
- ♦ Check the following items to increase mechanical system rigidity.
  - Lay the foundation firmly and set up a machine so that it does not wobble.
  - Use a Decelerator with minimal backlash.
  - Use couplings of a type with high rigidity and designed for servo systems.
  - Use a wide timing belt, and use a tension within the allowable axial load for the Servomotor.

## 7-2 Realtime Autotuning

Realtime autotuning estimates the load inertia of the machine in realtime, and automatically sets the optimal gain according to the estimated load inertia. The adaptive filter automatically suppresses vibration caused by resonance. In the default settings realtime autotuning is disabled. Refer to the following procedures to enable realtime autotuning.

### Precautions for Correct Use

- ◆ Realtime autotuning may not function properly under the conditions described in the following table. If realtime autotuning does not function properly, use autotuning or manual tuning.

	Conditions under which realtime autotuning does not function properly
Load inertia	<ul style="list-style-type: none"> <li>◆ If the load inertia is less than 3 times the rotor inertia.</li> <li>◆ If the load inertia is more than 20 times the rotor inertia.</li> <li>◆ If the load inertia changes quickly, i.e., in less than 10 seconds.</li> </ul>
Load	<ul style="list-style-type: none"> <li>◆ If the machine rigidity is extremely low.</li> <li>◆ If there is backlash or play in the system.</li> <li>◆ If the static friction torque is greater than the dynamic friction torque.</li> </ul>
Operating pattern	<ul style="list-style-type: none"> <li>◆ If the Servomotor is continuously run at a low speed below 100 r/min.</li> <li>◆ If the acceleration/deceleration is gradual at less than 2000 r/min in 1 s.</li> <li>◆ For abrupt operations, e.g., if the speed or acceleration condition is met in less than 40 ms.</li> <li>◆ If the acceleration/deceleration torque is unbalanced and smaller compared to the viscous friction torque.</li> </ul>

### Realtime Autotuning Setting Method

#### 1. Stopping the Servomotor

- ◆ Turn OFF the RUN Command Input (RUN) to the Servomotor. The Servomotor will stop.

#### 2. Realtime Autotuning Mode Selection (Pn21)

Pn21 Setting

Setting	Realtime Autotuning	Degree of change in load inertia during operation	Adaptive filter
0	Not used	---	Disabled
1	Used	Almost no change in load inertia	Enabled (Pn02 = 2)
2		Gradual changes in load inertia	
3		Sudden changes in load inertia	
4		Almost no change in load inertia	Disabled
5		Gradual changes in load inertia	
6		Sudden changes in load inertia	
7	Not used	---	Enabled (Pn02 = 2)

- ◆ When the degree of load inertia change is high, set the value to 3 or 6.
- ◆ Enable the adaptive filter if the load inertia change is affected by resonance.

#### 3. Normal Operation

- ◆ Turn ON the RUN Command Input (RUN) and run the machine as usual.



**4. Machine Rigidity Selection**

- ♦ To increase responsiveness, gradually increase the setting of the Realtime Autotuning Machine Rigidity Selection (Pn22).
- ♦ If the machine produces an unusual noise or resonates, lower the setting.

**5. Saving Gain Adjustment Values**

- ♦ To save the gain setting, change to Parameter Write Mode and save the parameters in EEPROM. (For operation details, refer to *Parameter Write Mode* on page 6-16.)

**Precautions  
for Correct Use**

- ♦ The setting of the Realtime Autotuning Mode Selection is changed when the Unit power is turned ON, or when the RUN Command Input (RUN) is turned ON.
- ♦ To disable realtime autotuning, set Pn21 to 0, and then turn OFF the RUN Command Input (RUN) and turn it ON again.

**Operating Procedures**

Insert the connector of the Parameter Unit into CN2 of the Servo Drive, and then turn ON the power to the Servo Drive.

r 0

**Setting Parameter Pn21**

Press the Data key.

Un SPD

Press the Mode key.

Pn 00

Press the Increment or Decrement key to select the parameter to be set. (In this case, select Pn21.)

Pn 21

Press the Data key.

1

Press the Increment or Decrement key to change the setting.

Press the Data key.

Pn 21

**Setting Parameter Pn22**

Press the Increment key to set the parameter number to Pn22.

Pn 22

Press the Data key.

4

Press the Increment key to increase the setting. (Default setting)

Press the Decrement key to decrease the setting.

Press the Data key.

Writing in EEPROM

Press the Mode key.

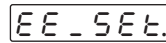

Press the Data key.

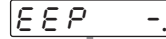

Press the Increment key for at least 5 s.  
The bars will increase as shown in the diagram on the right.

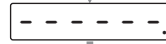
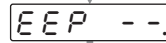

Writing will start.  
("Start" will be displayed momentarily.)

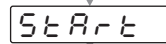

Writing completed.

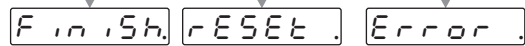

Writing completed      Writing error occurred

After writing has been completed, return to the display for Parameter Write Mode.

Adaptive Filter

The adaptive filter will be enabled if the Control Mode Selection (Pn02) is set to advanced position control (setting of 2) and the Realtime Autotuning Mode Selection (Pn21) is set to 1 to 3 or 7.

The adaptive filter estimates the resonance frequency from the vibration component in the motor speed during operation, eliminates the resonance component from the torque command by automatically setting the notch filter coefficient, and suppresses the resonance point vibration.

Precautions for Correct Use

- ♦ The adaptive filter may not function properly under the conditions described in the following table. In that case, use manual tuning with Notch Filter 1 Frequency (Pn1D) and Notch Filter 1 Width (Pn1E) as a countermeasure for resonance. (For details on the notch filter, refer to *Machine Resonance Control* on page 7-21.)

Conditions under which the adaptive filter does not function properly	
Resonance points	<ul style="list-style-type: none"> <li>♦ If the resonance frequency is 300 Hz or less.</li> <li>♦ If the resonance peak or control gain is low, and the Servomotor speed is not affected by it.</li> <li>♦ If there are multiple resonance points.</li> </ul>
Load	<ul style="list-style-type: none"> <li>♦ If the Servomotor speed with high frequency components varies due to backlash or other non-linear elements.</li> </ul>
Operating pattern	<ul style="list-style-type: none"> <li>♦ If the acceleration/deceleration suddenly changes i.e., 3000 r/min or more in 0.1 s.</li> </ul>

## Automatically Set Parameters

When realtime autotuning is enabled, the following parameters will be set automatically. Parameters that are set automatically cannot be changed manually.

Parameter No. (Pn No.)	Parameter name
10	Position Loop Gain
11	Speed Loop Gain
12	Speed Loop Integration Time Constant
13	Speed Feedback Filter Time Constant
14	Torque Command Filter Time Constant
18	Position Loop Gain 2
19	Speed Loop Gain 2
1A	Speed Loop Integration Time Constant 2
1B	Speed Feedback Filter Time Constant 2
1C	Torque Command Filter Time Constant 2
20	Inertia Ratio
2F	Adaptive Filter Table Number Display

The following parameters are set automatically. (The settings will not change even if realtime autotuning is executed.)

(Pn No.)	Parameter name	Set value
15	Feed-forward Amount	300
16	Feed-forward Command Filter	50
30	Gain Switching Input Operating Mode Selection	1
31	Gain Switch Setting	10
32	Gain Switch Time	30
33	Gain Switch Level Setting	50
34	Gain Switch Hysteresis Setting	33
35	Position Loop Gain Switching Time	20

### Precautions for Correct Use

- ♦ An unusual noise or resonance may occur right after turning ON the first RUN Command Input (RUN) after the power ON, or when the setting of the Realtime Autotuning Machine Rigidity Selection (Pn22) is increased. Usually, the noise or resonance may continue until the load inertia is estimated, or the adaptive filter stabilizes. If the unusual noise or resonance stops immediately, there is no problem. However, if the unusual noise or resonance occurs for more than three reciprocating operations, perform the following measures in any order you can.
    - (1) Save the parameter settings when the machine operated normally to EEPROM.
    - (2) Decrease the setting of the Realtime Autotuning Machine Rigidity Selection (Pn22).
    - (3) Set the Realtime Autotuning Mode Selection (Pn21) to 0 to disable the adaptive filter. Then, enable realtime autotuning again. (Refer to *Disabling Realtime Autotuning* on page 7-13 for information on inertia estimation, resetting adaptive operations, and disabling realtime autotuning.)
    - (4) Set Notch Filter 1 Frequency (Pn1D) and Notch Filter 1 Width (Pn1E) manually. (For information on notch filters, refer to *Machine Resonance Control* on page 7-21.)
  - ♦ After an unusual noise or resonance occurred, the setting of the Inertia Ratio (Pn20) or Adaptive Filter Table Number Display (Pn2F) may have been changed to an extreme value. Perform the above measures as well.
  - ♦ Among the realtime autotuning results, the Inertia Ratio (Pn20) and Adaptive Filter Table Number Display (Pn2F) parameters are automatically saved to EEPROM every 30 minutes. Realtime autotuning will use this data as the default settings when the power is turned ON.
-

## 7-3 Autotuning

Autotuning operates the Servomotor according to command patterns created automatically in the Servo Drive, estimates the load inertia from the required torque and automatically sets the optimal gain.

### Precautions for Correct Use

- ♦ Autotuning may not function properly under the conditions described in the following table. If autotuning does not function properly, use manual tuning.

	Conditions under which autotuning does not function properly
Load inertia	<ul style="list-style-type: none"> <li>♦ If the load inertia is less than 3 times the rotor inertia.</li> <li>♦ If the load inertia is more than 20 times the rotor inertia.</li> <li>♦ If the load inertia changes.</li> </ul>
Load	<ul style="list-style-type: none"> <li>♦ If the machine rigidity is extremely low.</li> <li>♦ If there is backlash or play in the system.</li> <li>♦ If the static friction torque is greater than the dynamic friction torque.</li> </ul>

- ♦ A tuning error will occur if the servo turns OFF (e.g., the RUN Command Input (RUN) turns OFF), or a deviation counter reset occurs (e.g., the Deviation Counter Reset (ECRST)) during the autotuning.
- ♦ If the load inertia cannot be estimated during autotuning, the setting of each gain cannot be changed and remains the same as before autotuning.
- ♦ When autotuning is being executed, the Servomotor output torque will reach the maximum output torque set in the Torque Limit (Pn5E).
- ♦ When autotuning is being executed, the Forward Drive Prohibit Input and Reverse Drive Prohibit Input will be ignored.

### Precautions for Safe Use

- ♦ If the Servomotor oscillates, immediately cut off the power, or turn OFF the RUN Command Input (RUN). Then, return each gain to the default setting.

## Autotuning Setting Method

### 1. Setting the Operating Pattern

- ♦ Set the operating pattern using the Autotuning Operation Setting (Pn25).
- ♦ The operating pattern set in Pn25 will repeat in a maximum of five cycles. Starting with the third cycle, the acceleration level will double every cycle.
- ♦ Depending on the load, the operating pattern does not repeat in five cycles when operation is completed, or the acceleration does not change. In either case, this is not an error.

### 2. Moving the Load

- ♦ Move the load to the position where there's no problem if the Servomotor operates according to the setting in Pn25. The Servomotor will rotate once or twice in both forward and reverse depending on the settings.

### 3. Moving to the Autotuning Mode Display

- ♦ For information on moving to the Autotuning Mode Display, refer to *Autotuning Mode* on page 6-17.

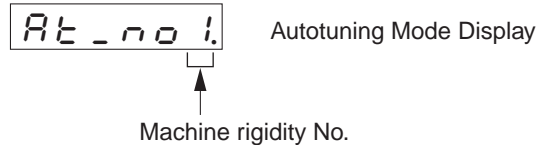

**4. Selecting Machine Rigidity**

- ◆ Press the Increment or Decrement key to select the machine rigidity number.

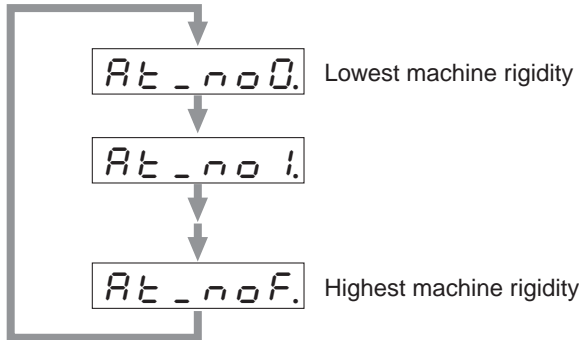

- ◆ The machine rigidity number sets the machine rigidity, and can be set to a value from 0 to F hex.
- ◆ The greater the machine rigidity, the higher the machine rigidity number is. The higher the machine rigidity is set, the higher the gain can be set.
- ◆ Under normal conditions, set the machine rigidity gradually from a low level in autotuning. Set the value in a range where an unusual noise, oscillation, and vibration do not occur.

**Reference Machine Rigidity Number Setting by Machine Drive System**

Drive system	Machine rigidity No.
Ball screw direct coupling	6 to C
Ball screw + timing belt	4 to A
Timing belt	2 to 8
Gear, rack and pinion drive	2 to 8
Machine with low rigidity, etc.	0 to 4

Machine rigidity numbers D to F can be used for machines with no resonance, high rigidity, and a low inertia ratio.

**5. Moving to Autotuning Mode**

- ◆ After setting the machine rigidity, press the Data key to move to Autotuning Mode. (For details, refer to *Autotuning Mode* on page 6-17.)



**6. Turning ON the Servo**

- ◆ Turn ON the RUN Command Input (RUN). The Servo will turn ON.

**7. Executing Autotuning**

- ◆ Press and hold the Increment key until `StArt` is displayed. (For details, refer to *Autotuning Mode* on page 6-17.)
- ◆ The Servomotor will rotate and autotuning will begin. The operating pattern depends on the Autotuning Operation Setting (Pn25). If Pn25 is set to 0, the Servomotor will rotate two times in

both forward and reverse for approximately 15 seconds. This will be repeated up to 5 cycles. It is not an error if the Servomotor stops before cycling 5 times.

- ♦ Repeat step 4 (Selecting Machine Rigidity) to step 7 (Executing Autotuning) until satisfactory responsiveness can be obtained.

### 8. Saving the Gain Settings

- ♦ When system responsiveness is satisfactory, move to Parameter Write Mode and save the settings in EEPROM so they will not be lost. (For details on operations, refer to *Parameter Write Mode* on page 6-16.)
- ♦ To save the new settings, move to Parameter Write Mode and save the parameters in EEPROM.

#### Precautions for Correct Use

- ♦ Execute autotuning when a load is connected. If autotuning is executed without a load (i.e., Servomotor/Servo Drive only) the Inertia Ratio (Pn20) will be 0.
- ♦ A tuning error will occur if any of the following conditions occur while autotuning is being executed.
  - (1) If an error occurs. If the Servo is turned OFF, e.g., the RUN Command Input (RUN) is turned OFF. If the deviation counter is reset, e.g., using the Deviation Counter Reset Input (ECRST). If auto tuning is executed near a limit sensor.
  - (2) If the inertia or load is too large and the output torque becomes saturated.
  - (3) If oscillation occurs and tuning cannot be performed correctly.
- ♦ If a tuning error occurs, the setting of each gain parameter will return to the value before tuning was executed. Except for times when an error occurs, the Servomotor will not stop.
- ♦ Depending on the load, the `ERROR` message does not appear and oscillation may occur.

### Autotuning Operation Waveform

The following figure illustrates how the operation waveform will appear when autotuning is executed. The waveform will be distorted immediately after the execution, but will gradually smooth out.

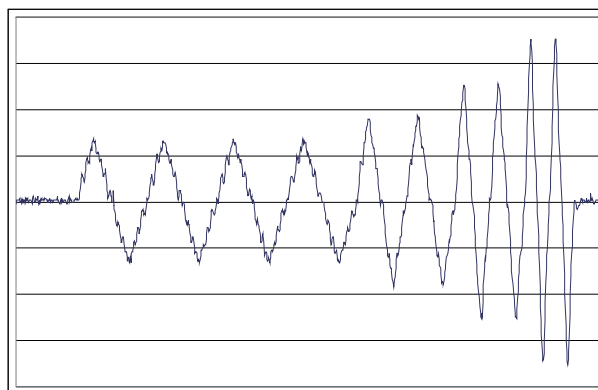

## Automatically Set Parameters

The following parameters will be set automatically according to the autotuning machine rigidity number selected.

Pn No.	Parameter name	Machine Rigidity No.							
		0	1	2	3	4	5	6	7
10	Position Loop Gain	27	32	39	48	63	72	90	108
11	Speed Loop Gain	15	18	22	27	35	40	50	60
12	Speed Loop Integration Time Constant	37	31	25	21	16	14	12	11
13	Speed Feedback Filter Time Constant	0	0	0	0	0	0	0	0
14	Torque Command Filter Time Constant	152	126	103	84	65	57	45	38
18	Position Loop Gain 2	31	38	46	57	73	84	105	126
19	Speed Loop Gain 2	15	18	22	27	35	40	50	60
1A	Speed Loop Integration Time Constant 2	1000	1000	1000	1000	1000	1000	1000	1000
1B	Speed Feedback Filter Time Constant 2	0	0	0	0	0	0	0	0
1C	Torque Command Filter Time Constant 2	152	126	103	84	65	57	45	38
20	Inertia Ratio	Estimated load inertia ratio							

7

Pn No.	Parameter name	Machine Rigidity No.							
		8	9	A	B	C	D	E	F
10	Position Loop Gain	135	162	206	251	305	377	449	557
11	Speed Loop Gain	75	90	115	140	170	210	250	310
12	Speed Loop Integration Time Constant	9	8	7	6	5	4	4	3
13	Speed Feedback Filter Time Constant	0	0	0	0	0	0	0	0
14	Torque Command Filter Time Constant	30	25	25	25	25	25	25	25
18	Position Loop Gain 2	157	188	241	293	356	440	524	649
19	Speed Loop Gain 2	75	90	115	140	170	210	250	310
1A	Speed Loop Integration Time Constant 2	1000	1000	1000	1000	1000	1000	1000	1000
1B	Speed Feedback Filter Time Constant 2	0	0	0	0	0	0	0	0
1C	Torque Command Filter Time Constant 2	30	25	20	16	13	11	10	10
20	Inertia Ratio	Estimated load inertia ratio							

**Reference** ♦ The parameter default values are set according to the machine rigidity number. The parameter settings are automatically changed when autotuning is executed.



The following parameters are set automatically. (The settings will not be changed even if realtime autotuning is executed.)

Pn No.	Parameter name	Machine Rigidity No.
		0 to F
15	Feed-forward Amount	300
16	Feed-forward Command Filter	50
30	Gain Switching Input Operating Mode Selection	1
31	Gain Switch Setting	10
32	Gain Switch Time	30
33	Gain Switch Level Setting	50
34	Gain Switch Hysteresis Setting	33
35	Position Loop Gain Switching Time	20

- ◆ Regardless of the machine rigidity number, the settings cannot be changed.

---

---

## 7-4 Disabling the Automatic Gain Adjustment Function

---

This section explains how to disable realtime autotuning and the adaptive filter. These functions are enabled by default.

---

**Precautions  
for Correct Use**

- ◆ When disabling the automatic adjustment function, the RUN Command Input (RUN) must be turned OFF.
- 

### Disabling Realtime Autotuning

By setting the Realtime Autotuning Mode Selection (Pn21) to 0 or 7, the automatic estimation of the Inertia Ratio (Pn20) will stop and realtime autotuning will be disabled.

However, the estimated results of the Inertia Ratio (Pn20) will remain. If the Pn20 value is obviously incorrect, perform autotuning or set the calculated value manually after disabling realtime autotuning.

---

**Precautions  
for Correct Use**

- ◆ To enable the Realtime Autotuning Mode Selection (Pn21), turn OFF the RUN Command Input (RUN), and then turn it back ON.
-

## Disabling the Adaptive Filter

Setting the Realtime Autotuning Mode Selection (Pn21) to 0 or 4 to 6 will disable the adaptive filter which automatically adjusts for load resonance. If the properly functioning adaptive filter is disabled, the effect of the suppressed resonance may appear, and noise and vibration may occur. Disable the adaptive filter only after manually setting the Notch Filter 1 Frequency (Pn1D) based on the displayed value of the Adaptive Filter Table Number Display (Pn2F).

Displayed value	Notch Filter 1 Frequency (Hz)	Displayed value	Notch Filter 1 Frequency (Hz)	Displayed value	Notch Filter 1 Frequency (Hz)
0	Disabled	22	766	44	326
1	Disabled	23	737	45	314
2	Disabled	24	709	46	302
3	Disabled	25	682	47	290
4	Disabled	26	656	48	279
5	1482	27	631	49	269 (Disabled when Pn22 ≥ F)
6	1426	28	607	50	258 (Disabled when Pn22 ≥ F)
7	1372	29	584	51	248 (Disabled when Pn22 ≥ F)
8	1319	30	562	52	239 (Disabled when Pn22 ≥ F)
9	1269	31	540	53	230 (Disabled when Pn22 ≥ F)
10	1221	32	520	54	221 (Disabled when Pn22 ≥ E)
11	1174	33	500	55	213 (Disabled when Pn22 ≥ E)
12	1130	34	481	56	205 (Disabled when Pn22 ≥ E)
13	1087	35	462	57	197 (Disabled when Pn22 ≥ E)
14	1045	36	445	58	189 (Disabled when Pn22 ≥ E)
15	1005	37	428	59	182 (Disabled when Pn22 ≥ D)
16	967	38	412	60	Disabled
17	930	39	396	61	Disabled
18	895	40	381	62	Disabled
19	861	41	366	63	Disabled
20	828	42	352	64	Disabled
21	796	43	339		

♦ When the Adaptive Filter Table Number Display (Pn2F) is greater than 49, the Realtime Autotuning Machine Rigidity Selection (Pn22) may have automatically disabled the adaptive filter. In this case, the Notch Filter 1 Frequency (Pn1D) does not need to be set.

## 7-5 Manual Tuning

Use manual tuning to adjust the gain when adjustments cannot be made properly with autotuning (described in the previous section) due to load conditions or other restrictions, or when loads that have been adjusted with autotuning need to be readjusted individually to achieve optimal response and stability.

This section explains manual tuning, which is used to manually adjust the gain.

### Function Differences in Control Modes

The following table shows the adjustment ranges of manual tuning for each control mode.

Pn02 setting	Control Mode	Basic adjustment	Gain switch	Torque filter	Notch filter	Damping control switch
0	High-response Position Control	Supported.	Supported.	Supported.	Supported (See note.)* <sup>1</sup>	Supported (See note.)* <sup>1</sup>
1	Internally Set speed Control	Supported.	Supported.	Supported.	Supported.	Not supported.
2	Advanced Position Control	Supported.	Supported.	Supported.	Supported.	Supported.

\*1. The notch filter and damping control cannot be used at the same time in High-response Position Control. The parameter entered first will be given priority.

Example:

When damping control is set, the Servo Drive will be forcibly set to 1500 (disabled), even if the Notch Filter 1 Frequency (Pn1D) is input.

## Basic Adjustment Procedures

### ■ Adjustment in Position Control Mode

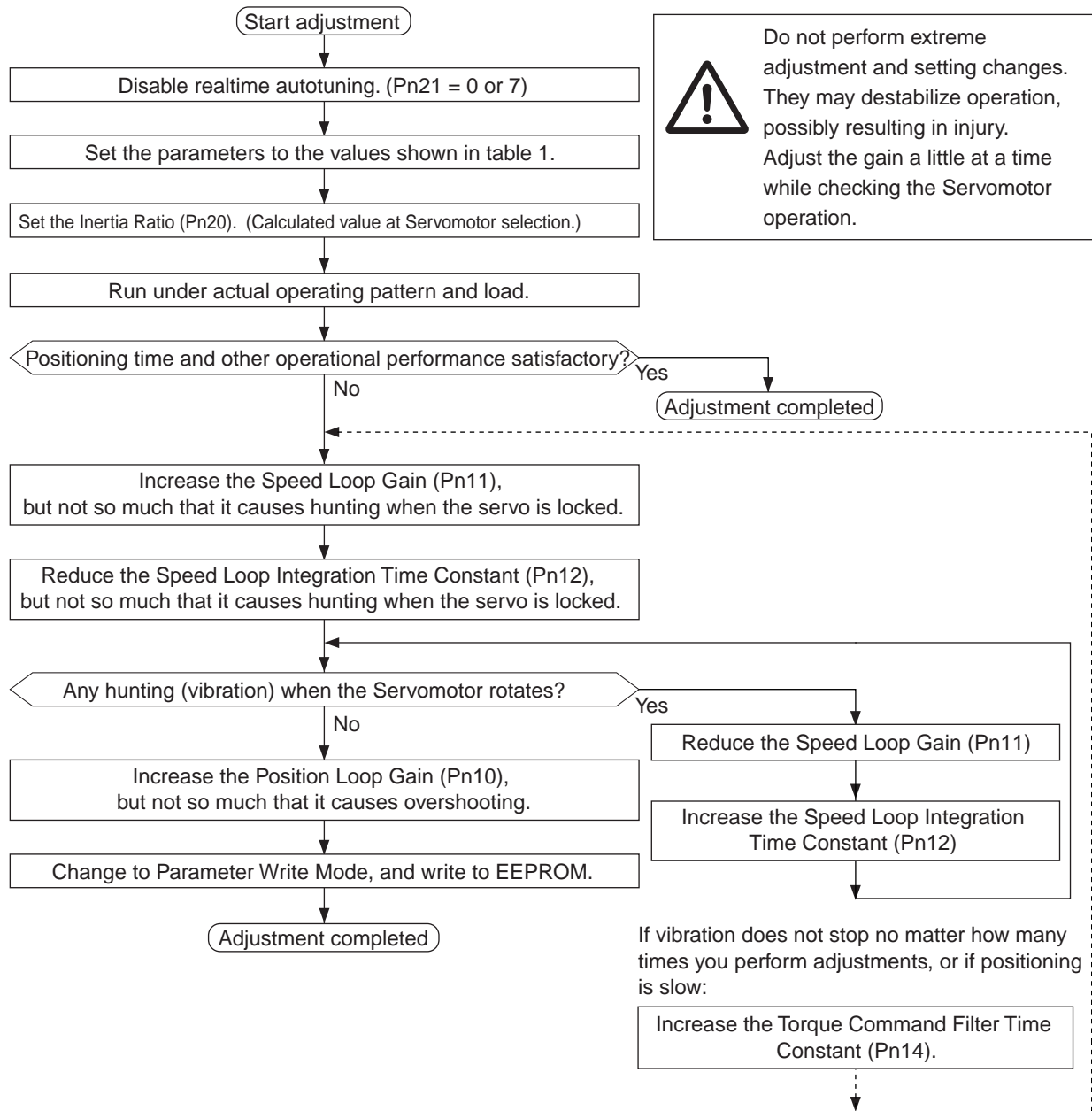

■ Adjustment in Internally Set Speed Control Mode

The following parameters are adjustable: Speed Loop Gain (Pn11 and Pn19), Speed Loop Integration Time Constant (Pn12 and Pn1A), and Torque Command Filter Time Constant (Pn14 and Pn1C).

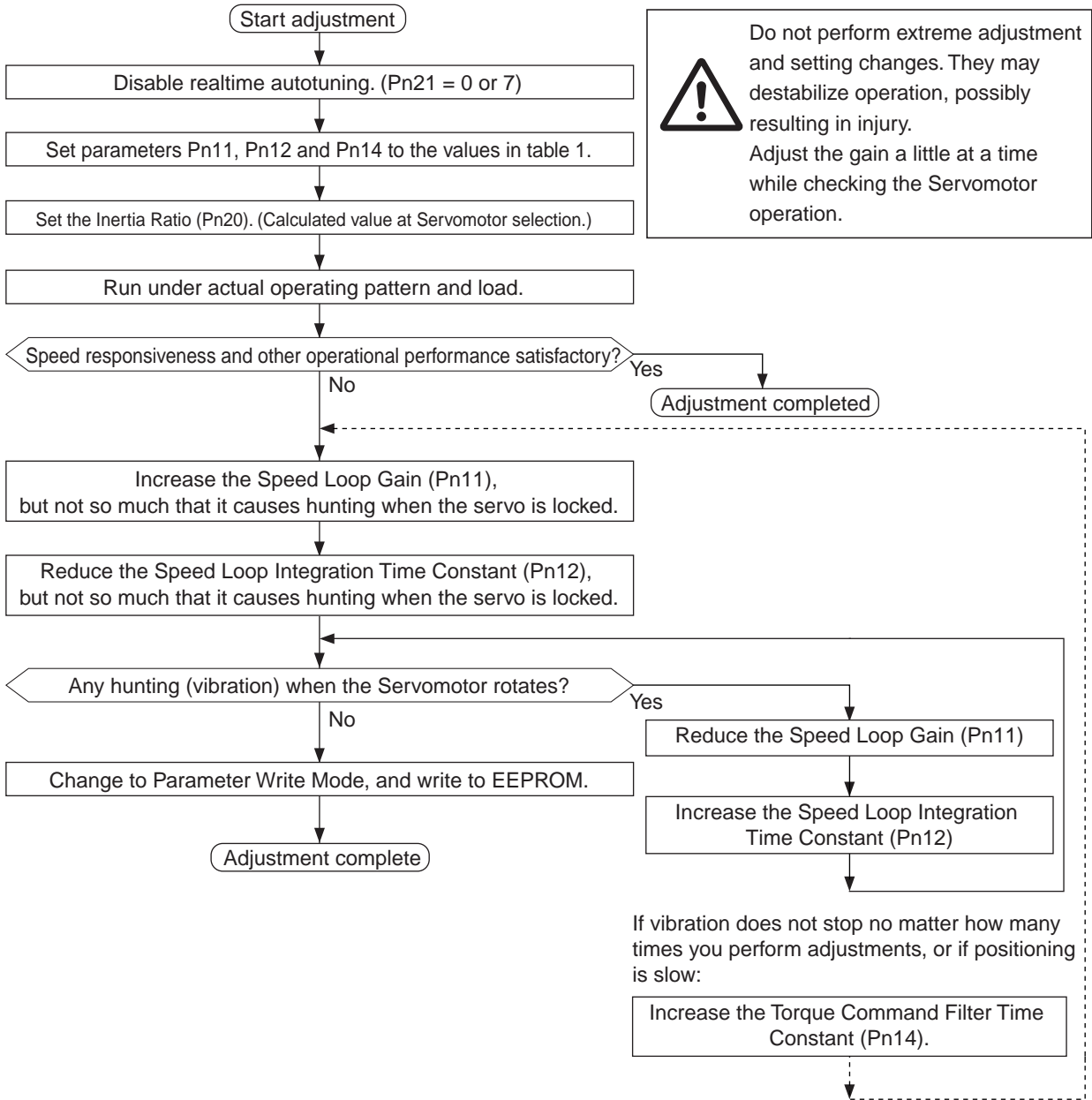

7

Adjustment Functions

Table 1 :Parameter Adjustment Guidelines

Pn No.	Parameter name	Guideline
10	Position Loop Gain	27
11	Speed Loop Gain	15
12	Speed Loop Integration Time Constant	37
13	Speed Feedback Filter Time Constant	0
14	Torque Command Filter Time Constant	152
15	Feed-forward Amount	0
16	Feed-forward Command Filter	0
18	Position Loop Gain 2	27
19	Speed Loop Gain 2	15
1A	Speed Loop Integration Time Constant 2	37
1B	Speed Feedback Filter Time Constant 2	0
1C	Torque Command Filter Time Constant 2	152
1D	Notch Filter 1 Frequency	1500
1E	Notch Filter 1 Width	2
20	Inertia Ratio	*1

\*1. Input the Inertia Ratio (Pn20). The inertia ratio can be measured with autotuning or set to a calculated value. When the inertia ratio is unknown, set 300 in Pn20.

## Gain Switching Function

With manual tuning, gain 1 and gain 2 can be set manually. For example, the gain can be switched according to the following conditions.

- ♦ To increase responsiveness by increasing the gain during operation.
- ♦ To increase servo lock rigidity by increasing the gain when operation is stopped.
- ♦ To switch to an optimal gain according to the Operating Mode.
- ♦ To reduce the gain to suppress vibration when operation is stopped.

The function of switching from gain 1 to gain 2 can be used in a variety of applications.

### ■ Explanation of Settings

To use the gain switching function, the Gain Switching Input Operating Mode Selection (Pn30) and Gain Switch Setting (Pn31) parameters must be set. For details on parameter settings, refer to *Parameter Details* on page 5-32.

#### Gain Switching Input Operating Mode Selection (Pn30)

Set Pn30 to 1 to enable the gain switching function.

#### Gain Switch Setting (Pn31)

Gain switching can be used by first enabling the gain switching function and then setting the switching conditions for gain 1 and gain 2 with Gain Switch Setting (Pn31).

Pn31 setting	Explanation			
	Gain switch condition	Gain Switch Time (Pn32) <sup>*1</sup>	Gain Switch Level Setting (Pn33)	Gain Switch Hysteresis Setting (Pn34) <sup>*2</sup>
0	Always gain 1 (Pn10 to Pn14)	Disabled	Disabled	Disabled
1	Always gain 2 (Pn18 to Pn1C)	Disabled	Disabled	Disabled
2	Switching using Gain Switch Input (GSEL) at pin CN1-5	Disabled	Disabled	Disabled
3	Amount of change in torque command (Figure A)	Enabled	Enabled <sup>*3</sup> (× 0.05%)	Enabled <sup>*3</sup> (× 0.05%)
4	Always gain 1 (Pn10 to Pn14)	Disabled	Disabled	Disabled
5	Command speed (Figure B)	Enabled	Enabled (r/min)	Enabled (r/min)
6	Amount of position deviation (Figure C)	Enabled	Enabled <sup>*4</sup> (pulse)	Enabled <sup>*4</sup> (pulse)
7	Command pulses received (Figure D)	Enabled	Disabled	Disabled
8	Positioning Completed Signal (INP) OFF (Figure E)	Enabled	Disabled	Disabled
9	Actual Servomotor speed (Figure B)	Enabled	Enabled (r/min)	Enabled (r/min)
10	Combination of command pulse input and speed (Figure F)	Enabled	Enabled <sup>*5</sup> (r/min)	Enabled <sup>*5</sup> (r/min)

\*1. The Gain Switch Time (Pn32) is used when switching from gain 2 to gain 1.



\*2. The Gain Switch Hysteresis Setting (Pn34) is defined as shown in the following figure.

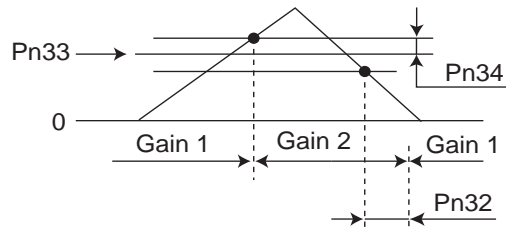

\*3. The amount of change is the value within 166  $\mu$ s.

Example: When the condition is a 10% change in torque in 166  $\mu$ s, the set value is 200.

\*4. This is the encoder resolution value.

\*5. The meanings of the Gain Switch Time, Gain Switch Level Setting, and Gain Switch Hysteresis Setting are different from normal if this parameter is set to 10. (Refer to Figure F.)

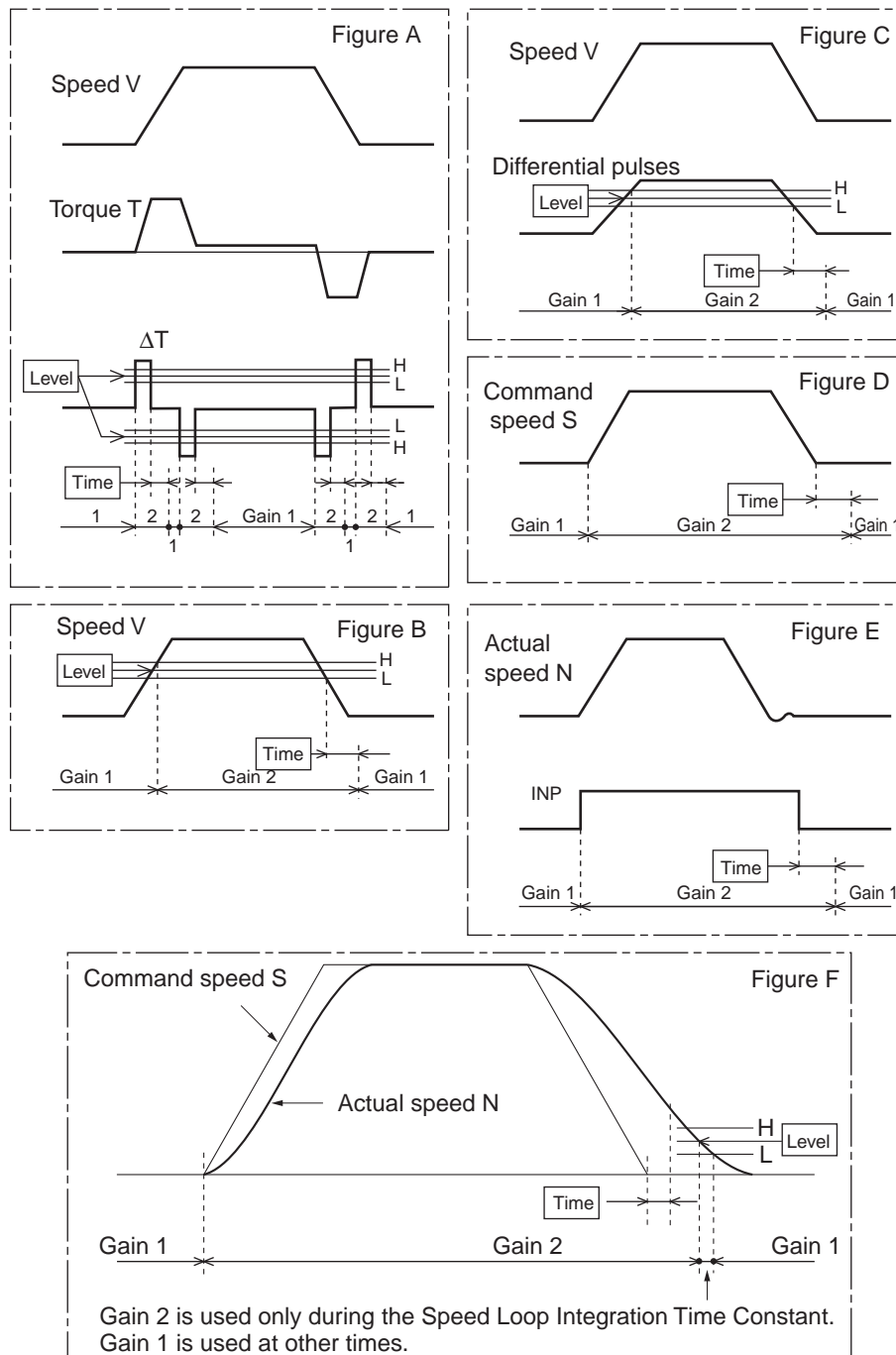

## Machine Resonance Control

When machine rigidity is low, shaft torsion may cause resonance, leading to vibration or noise, thus not allowing the gain to be set high. In this case, the resonance can be suppressed by using the two filter types.

### ■ Torque Command Filter Time Constant (Pn14, Pn1C)

The filter time constant is set to attenuate the resonance frequency. The cut-off frequency can be calculated using the following equation.

$$\text{Cut-off frequency (Hz)} \quad f_c = \frac{1}{2\pi T} = \frac{1}{2\pi \times \text{Parameter setting} \times 10^{-5}}$$

### ■ Notch Filter

#### Adaptive Filter (Pn21, Pn2F)

By using the adaptive filter, the Servo Drive can suppress vibration of loads with various resonance points for each machinery, which conventional notch filters or torque command filters were unable to cope with. Enable the adaptive filter by selecting advanced position control (2) for the Control Mode Selection (Pn02) and setting the Realtime Autotuning Mode Selection (Pn21) to 1 to 3 or 7.

Pn No.	Parameter name	Explanation
21	Realtime Autotuning Mode Selection	The adaptive filter is enabled when this parameter is set to 1 to 3, or 7.
2F	Adaptive Filter Table Number Display	Displays the table entry number corresponding to the frequency of the adaptive filter.*1 The setting of this parameter cannot be changed.

\*1. For information on table entry numbers and frequency, refer to *Disabling the Adaptive Filter* on page 7-14.

#### Notch Filter 1 (Pn1D, Pn1E)

Adjust the notch frequency of the notch filter according to the machine resonance frequency.

Notch Filter Function

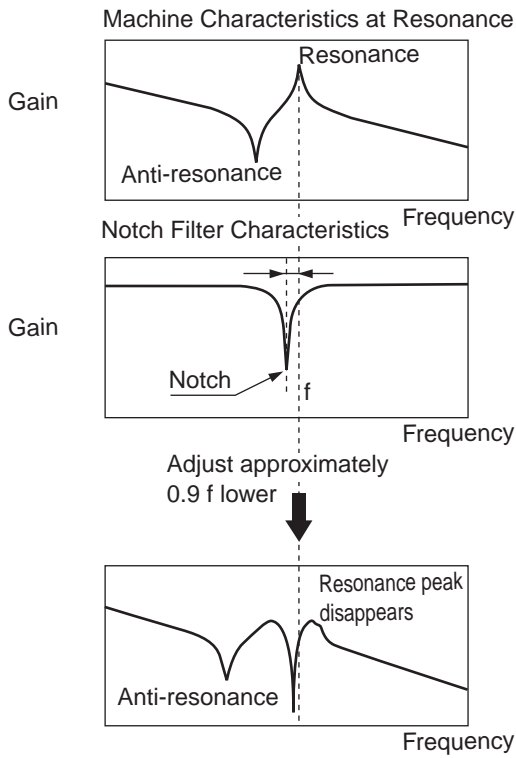

Torque Command Filter Function

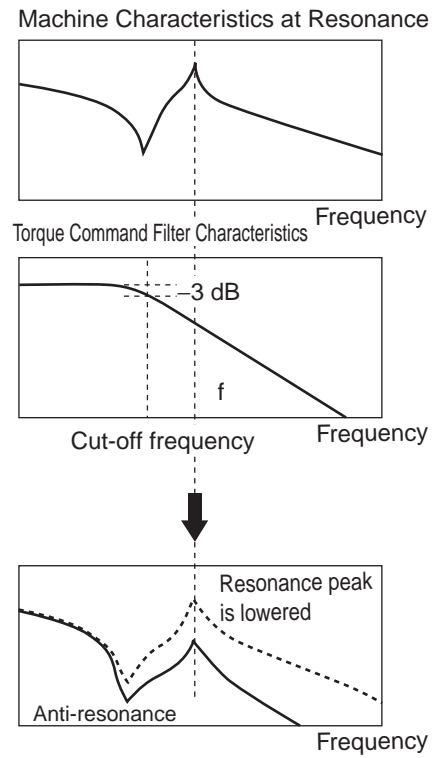

Example of an Adaptive Machine

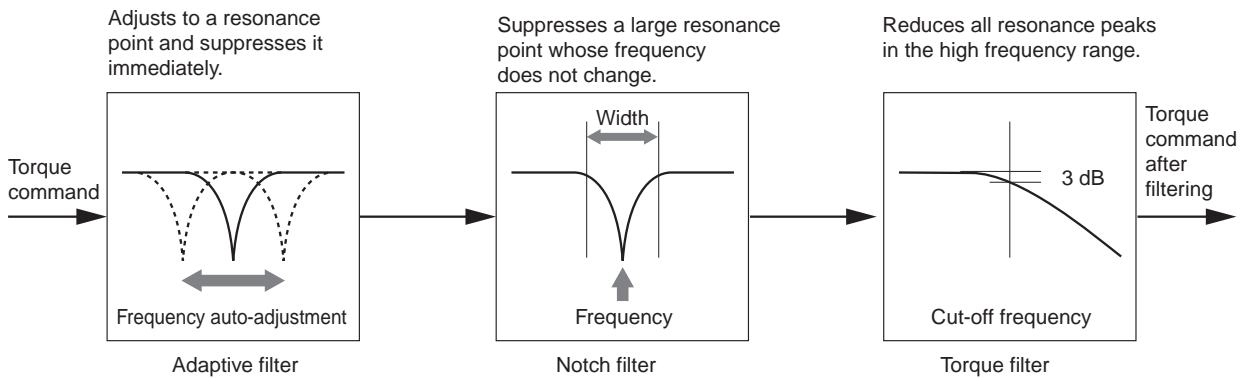
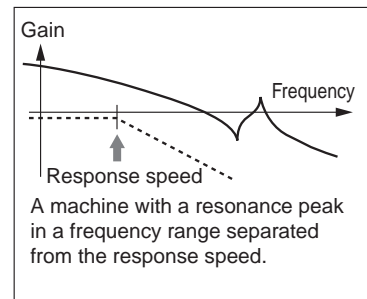
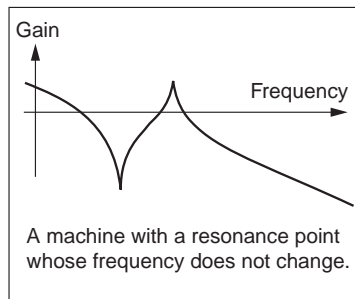
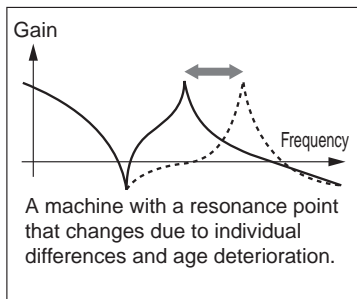

## Damping Control

When the machine end vibrates, damping control removes the vibration frequency component from the command and suppresses vibration.

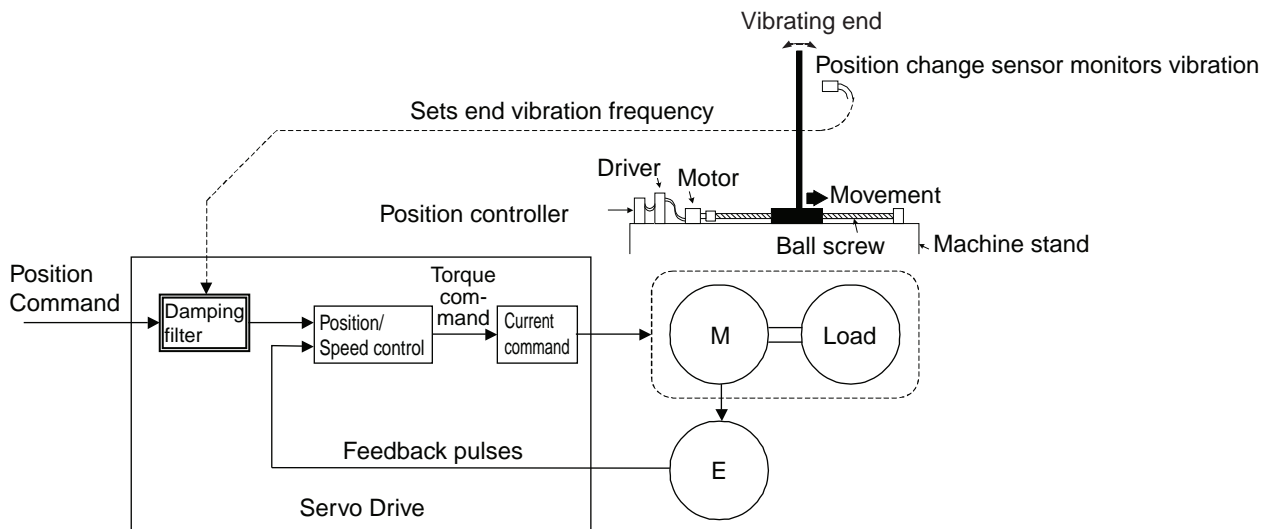

### Precautions for Correct Use

- The following conditions must be met to use damping control.

Conditions under which damping control operates	
Control Mode	<ul style="list-style-type: none"> <li>The Position Control Mode must be used.</li> <li>If the Control Mode Selection (Pn02) is set to 0, realtime autotuning and notch filter 1 must be disabled in High-Response Position Control.</li> <li>If the Control Mode Selection (Pn02) is set to 2, Advanced Position Control Mode is used.</li> </ul>

- Stop operation before changing parameters.
- Under the following conditions, damping control may not operate properly or may have no effect.

Conditions under which the effect of damping control is inhibited	
Load	<ul style="list-style-type: none"> <li>When forces other than commands, such as external forces, cause vibration.</li> <li>When the difference between the resonance frequency and anti-resonance frequency is large.</li> <li>When the vibration frequency is large (more than 100 Hz).</li> </ul>

## ■ Operating Procedure

### 1. Setting the Vibration Frequency (Pn2B)

Measure the vibration frequency at the end of the machine. If the end vibration can be measured directly using a laser displacement sensor, read the vibration frequency (Hz) from the measured waveform and set it in the Vibration Frequency (Pn2B). If no measurement device is available, use the CX-Drive waveform graphic function, and read the residual vibration frequency (Hz) from the position deviation waveform as shown in the following figure. The set values from 0 to 99 are invalid.

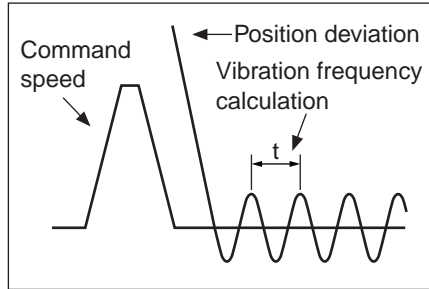

Measure the distance between the residual peaks ( $t$ ), and calculate the vibration frequency (Hz) using the following formula.

$$f \text{ (Hz)} = \frac{1}{t \text{ (s)}}$$

### 2. Setting the Vibration Filter (Pn2C)

First, set the Vibration Filter Setting (Pn2C) to 0. The settling time can be reduced by setting a large value, however, torque ripple will increase at the command change point as shown in the following figure.

Set in a range that will not cause torque saturation under actual operation conditions. The effects of vibration suppression will be lost if torque saturation occurs.

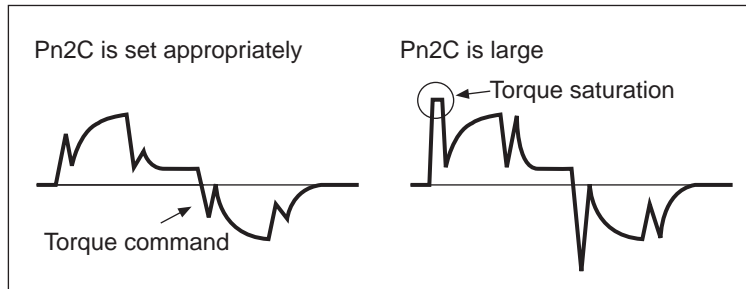



# Chapter 8

## Troubleshooting

<b>8-1</b>	<b>Error Processing</b> .....	<b>8-1</b>
	Preliminary Checks When a Problem Occurs .....	8-1
	Precautions When Troubleshooting .....	8-2
	Replacing the Servomotor and Servo Drive .....	8-2
<b>8-2</b>	<b>Alarm Table</b> .....	<b>8-3</b>
	Alarm Indicator on the Servo Drive .....	8-3
	Alarm List .....	8-4
<b>8-3</b>	<b>Troubleshooting</b> .....	<b>8-5</b>
	Points to Check .....	8-5
	Error Diagnosis Using the Displayed Alarm Codes .....	8-6
	Error Diagnosis Using the Operating Status .....	8-12
<b>8-4</b>	<b>Overload Characteristics</b> <b>(Electronic Thermal Function)</b> .....	<b>8-16</b>
	Overload Characteristics Graphs .....	8-16
<b>8-5</b>	<b>Periodic Maintenance</b> .....	<b>8-17</b>
	Servomotor Service Life .....	8-17
	Servo Drive Service Life .....	8-18

---

# 8-1 Error Processing

---

This section explains preliminary checks required to determine the cause of problems that might occur and cautions for the problems.

## Preliminary Checks When a Problem Occurs

This section explains the preliminary checks and analytical tools required to determine the cause of problems that might occur.

### ■ Checking the Power Supply Voltage

- ♦ Check the voltage at the power supply input terminals.

Main-circuit Power Supply Input Terminals (L1, (L2), L3)

R7D-BP□□L: Single-phase 100 to 115 VAC (85 to 127 V), 50/60 Hz

R7D-BP02HH: Single-phase 200 to 240 VAC (170 to 264 V), 50/60 Hz

R7D-BP□□H: Single-phase/three-phase 200 to 240 VAC (170 to 264 V), 50/60 Hz

R7D-BP02H: Three-phase 200 to 240 VAC (170 to 264 V), 50/60 Hz

If the voltage is outside of this range, there is a risk of operation failure. Be sure to supply the power correctly.

- ♦ Check the voltage for the sequence input power supply:

Within the range of 11 to 25 VDC (+24 VIN terminal (pin CN1-1)).

If the voltage is outside of this range, there is a risk of operation failure. Be sure to supply the power correctly.

### ■ Checking Whether an Alarm Has Occurred

Check the alarm LED indicator on the front of the Servo Drive to see whether an alarm has occurred, or check the alarm code on the Parameter Unit.

#### When an alarm has occurred:

- ♦ Check the status of the alarm LED indicator (ALM) and evaluate the problem based on the alarm indicated.
- ♦ Check the alarm code and perform analysis based on the alarm code information.

#### When an alarm has not occurred:

Make an analysis according to the problem.

**Note** In either case, refer to *8-3 Troubleshooting* for details.



---

## Precautions When Troubleshooting

When checking and verifying I/O after a problem has occurred, the Servomotor/Servo Drive may suddenly start to operate or stop, so always use the following precautions.

You should assume that anything not described in this manual is not possible with this product.

### ■ Precautions

- ♦ Disconnect the cable before checking for wire breakage. Even if you test conduction with the cable connected, test results may not be accurate due to conduction via bypassing circuit.
- ♦ If the encoder signal is lost, the Servomotor may run away, or an error may occur. Be sure to disconnect the Servomotor from the mechanical system before checking the encoder signal.
- ♦ When performing tests, first check that there are no persons in the vicinity or inside the equipment, and that the equipment will not be damaged even if the Servomotor runs away. Before performing the tests, verify that you can immediately stop the machine using an emergency stop even if the Servomotor runs away.

## Replacing the Servomotor and Servo Drive

Use the following procedure to replace the Servomotor or Servo Drive.

### ■ Replacing the Servomotor

1. **Replace the Servomotor.**
2. **Perform machine origin position alignment (for position control).**

- ♦ When the Servomotor is replaced, the Servomotor's origin position (phase Z) may deviate, so origin alignment must be performed.
- ♦ Refer to the Position Controller's operation manual for details on performing origin alignment.

### ■ Replacing the Servo Drive

1. **Copy the parameters.**
  - ♦ Use the copy function of the Parameter Unit to copy all the parameter settings to the Parameter Unit. Alternatively, use the Parameter Unit to display all the parameter settings and write them down.
2. **Replace the Servo Drive.**
3. **Set the parameters.**
  - ♦ Use the copy function of the Parameter Unit to transfer all the saved parameters to the Servo Drive. Alternatively, use the Parameter Unit to set all the parameters.

## 8-2 Alarm Table

If the Servo Drive detects an error, the Alarm Output (ALM) will turn ON, the power drive circuit will turn OFF, and the alarm code will be displayed. If a warning is detected (torque limit imposed, zero speed detection, over regeneration, overload, or fan rotation speed error), the Warning Output (WARN) will turn ON, and the warning will be displayed. (Operation will continue.)

### Precautions for Correct Use

- ♦ The Warning Output is output only for warnings set in the Warning Output Selection (Pn09).
- ♦ Refer to *Error Diagnosis Using the Displayed Alarm Codes* on page 8-6 for alarm countermeasures.
- ♦ Reset the alarm using one of the following methods. Be sure to remove the cause of the alarm before resetting.
  - Turn ON the Alarm Reset Input (RESET).
  - Turn OFF the power supply, then turn it ON again.
  - Perform the Alarm Reset operation on the Parameter Unit.
 The following alarms can only be reset by turning OFF the power supply, then turning it ON again: 14, 15, 18, 21, 23, 36, 37, 48, 49, 95, and 96.
- ♦ If you reset an alarm while the RUN Command (RUN) is turned ON, the Servo Drive will start operation as soon as the alarm is reset, which is dangerous. Be sure to turn OFF the RUN Command (RUN) before resetting the alarm.
 

If the RUN Command (RUN) is always ON, ensure safety thoroughly before resetting the alarm.

### Alarm Indicator on the Servo Drive

The alarm LED indicator on the front of the Servo Drive lights up if an error is detected. The indicator shows the alarm code by the number of orange and red flashes.

Example:

When an overload alarm (alarm code 16) has occurred and the Unit has stopped, the indicator will flash 1 time in orange and 6 times in red.

Orange: 10s digit, Red: 1s digit

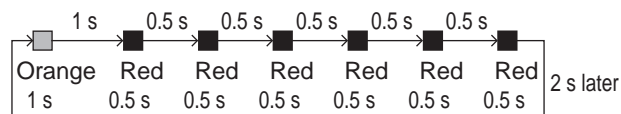

## Alarm List

Alarm code	Error detection function	Detection details and cause of error	Alarm reset possible
11	Power supply undervoltage	The DC voltage of the main circuit fell below the specified value while the RUN Command Input was ON.	Yes
12	Overvoltage	The DC voltage of the main circuit is abnormally high.	Yes
14	Overcurrent	Overcurrent flowed to the IGBT. Servomotor power line ground fault or short circuit.	No
15	Built-in resistor overheat	The resistor in the Servo Drive is abnormally overheating.	No
16	Overload	Operation was performed with torque significantly exceeding the rated level for several seconds to several tens of seconds.	Yes
18	Regeneration overload	The regeneration energy exceeded the processing capacity of the regeneration resistor.	No
21	Encoder disconnection detected	The encoder wiring is disconnected.	No
23	Encoder data error	Data from the encoder is abnormal.	No
24	Deviation counter overflow	The number of accumulated pulses in the deviation counter exceeded the setting in the Deviation Counter Overflow Level (Pn63).	Yes
26	Overspeed	The Servomotor exceeded the maximum number of rotations. If the torque limit function was used, the Servomotor's rotation speed exceeded the settings in the Overspeed Detection Level Setting (Pn70 and Pn73).	Yes
27	Electronic gear setting error	The setting in Electronic Gear Ratio Numerator 1 (Pn46) or Electronic Gear Ratio Numerator 2 (Pn47) is not appropriate.	Yes
29	Deviation counter overflow	The number of accumulated pulses for the deviation counter exceeded 134,217,728.	Yes
34	Overrun limit error	The Servomotor exceeded the allowable operating range set in the Overrun Limit Setting (Pn26).	Yes
36	Parameter error	Data in the parameter saving area was corrupted when data was read from the EEPROM at power ON.	No
37	Parameter corruption	The checksum didn't match when data was read from the EEPROM at power on.	No
38	Drive prohibit input error	The forward drive prohibit and reverse drive prohibit inputs are both turned OFF.	Yes
48	Encoder phase Z error	A phase-Z pulse was not detected regularly.	No
49	Encoder CS signal error	A logic error of the CS signal was detected.	No
95	Servomotor non-conformity	The combination of the Servomotor and Servo Drive is not appropriate. The encoder was not connected when the power supply was turned ON.	No
96	LSI setting error	Excessive noise caused the LSI setting not to be completed properly.	No
Others	Other errors	The Servo Drive's self-diagnosis function detected an error in the Servo Drive.	No

# 8-3 Troubleshooting

If an error occurs in the machine, determine the error conditions from the alarm indicator and operating status, identify the cause of the error, and take appropriate countermeasures.

## Points to Check

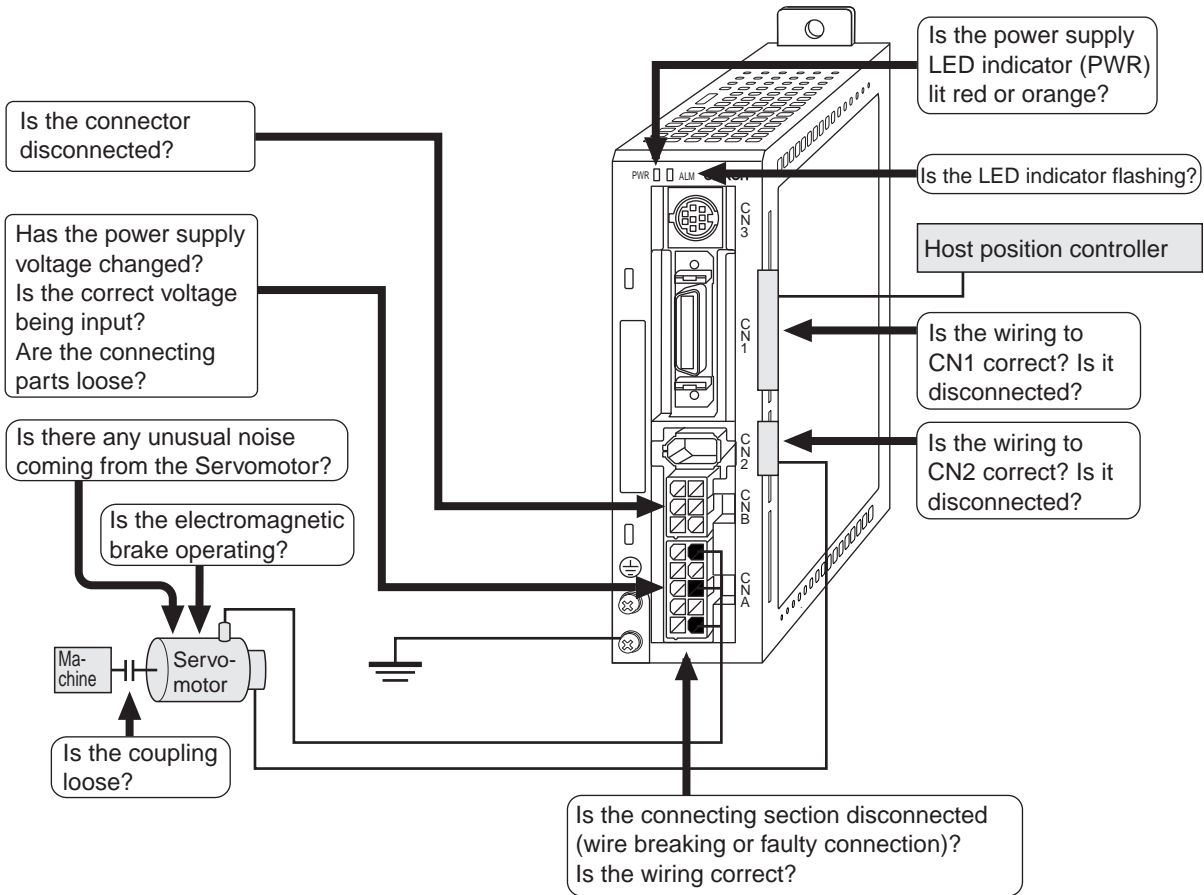

8

Troubleshooting

## Error Diagnosis Using the Displayed Alarm Codes

Alarm code	Error	Status when error occurs	Cause	Countermeasure
11	Power supply undervoltage	Occurs when the Servo Drive is turned ON.	<ul style="list-style-type: none"> <li>• The power supply voltage is low.</li> <li>• Momentary power interruption occurred.</li> <li>• Power supply capacity is insufficient.</li> <li>• The power supply voltage drops because the main power supply is OFF.</li> <li>• The main power supply is not input.</li> </ul>	<ul style="list-style-type: none"> <li>• Increase the power supply capacity.</li> <li>• Change the power supply.</li> <li>• Turn ON the power supply.</li> </ul>
			<ul style="list-style-type: none"> <li>• Power supply capacity is insufficient.</li> </ul>	<ul style="list-style-type: none"> <li>• Increase the power supply capacity.</li> </ul>
			<ul style="list-style-type: none"> <li>• Phase loss.</li> </ul>	<ul style="list-style-type: none"> <li>• Connect the phases (L1, L2, L3) of the power supply voltage correctly.</li> <li>• For single-phase, connect to L1 and L3 correctly.</li> </ul>
			<ul style="list-style-type: none"> <li>• The main circuit power supply part is damaged.</li> <li>• Control PCB error.</li> </ul>	<ul style="list-style-type: none"> <li>• Replace the Servo Drive.</li> </ul>
12	Overvoltage	Occurs when power supply is turned ON.	<ul style="list-style-type: none"> <li>• Main circuit power supply voltage is outside the allowable range.</li> </ul>	<ul style="list-style-type: none"> <li>• Change the main circuit power supply voltage to within the allowable range.</li> </ul>
		Occurs when the Servomotor is decelerating.	<ul style="list-style-type: none"> <li>• Load inertia is too large.</li> </ul>	<ul style="list-style-type: none"> <li>• Calculate the regenerative energy, and connect an External Regeneration Resistor with the required regeneration absorption capacity.</li> <li>• Extend the deceleration time.</li> </ul>
		Occurs during descent (vertical axis).	<ul style="list-style-type: none"> <li>• Main circuit power supply voltage is outside the allowable range.</li> </ul>	<ul style="list-style-type: none"> <li>• Change main circuit power supply voltage to within the allowable range.</li> </ul>
		Occurs during descent (vertical axis).	<ul style="list-style-type: none"> <li>• Gravitational torque is too large.</li> </ul>	<ul style="list-style-type: none"> <li>• Add a counterbalance to the machine to lower gravitational torque.</li> <li>• Slow the descent speed.</li> <li>• Calculate the regenerative energy, and connect an External Regeneration Resistor with the required regeneration absorption capacity.</li> </ul>

## 8-3 Troubleshooting

Alarm code	Error	Status when error occurs	Cause	Countermeasure
14	Overcurrent	Occurs when the Servo Drive is turned ON.	• Control PCB error	• Replace the Servo Drive.
			• Servomotor power line is short-circuited or ground-faulted between phases.	• Repair the short-circuited or ground-faulted wire. • Measure the insulation resistance at the Servomotor and, if there is a short-circuit, replace the Servomotor.
			• Miswiring between phase U, V, or W and ground.	• Correct the wiring.
			• Servomotor winding is burned out.	• Measure the wire wound resistance, and if the winding is burned out, replace the Servomotor.
			• The relay for the dynamic brake has been consequently welded.	• Do not frequently input the RUN Command Input. • Do not operate the system by turning the Servo Drive ON and OFF.
			• Servomotor non-conformity	• Use a Servomotor that is appropriate for use with the Servo Drive.
			• The pulse input timing is too fast.	• Wait 100 ms min. before inputting pulses after turning ON the RUN Command Input (RUN).
			• The resistor in the Servo Drive is abnormally overheating.	• Reduce the ambient temperature of the Servo Drive to 55°C or lower. • If the relay does not click when the power supply is turned ON, replace the Servo Drive.
16	Overload	Occurs when the Servo Drive is turned ON.	• There is an error in the Servomotor wiring (e.g., the wiring or the contacts are faulty).	• Wire the Servomotor Power Cable correctly.
			• The electromagnetic brake is ON.	• Reset the brake.
			• The Servo Drive is faulty.	• Replace the Servo Drive.
		Occurs during operation.	• The actual torque exceeds the rated torque. • The starting torque exceeds the maximum torque.	• Review the load conditions and operating conditions. • Review the Servomotor capacity.
			• An unusual noise oscillation or vibration is caused by faulty gain adjustment.	• Adjust the gain correctly.
			• The Servo Drive is faulty.	• Replace the Servo Drive.

Alarm code	Error	Status when error occurs	Cause	Countermeasure
18	Regeneration overload	Occurs when the Servomotor is decelerating.	<ul style="list-style-type: none"> <li>• Load inertia is too large.</li> </ul>	<ul style="list-style-type: none"> <li>• Calculate the regenerative energy, and connect an External Regeneration Resistor with the required regeneration absorption capacity.</li> <li>• Extend the deceleration time.</li> </ul>
			<ul style="list-style-type: none"> <li>• The deceleration time is too short.</li> <li>• The Servomotor rotation speed is too high.</li> </ul>	<ul style="list-style-type: none"> <li>• Reduce the Servomotor rotation speed.</li> <li>• Extend the deceleration time.</li> <li>• Calculate the regenerative energy, and connect an External Regeneration Resistor with the required regeneration absorption capacity.</li> </ul>
			<ul style="list-style-type: none"> <li>• The operating limit of the External Regeneration Resistor is limited to 10%.</li> </ul>	<ul style="list-style-type: none"> <li>• Set Pn6C to 2. For details, refer to <i>Parameter Details</i> on page 5-32.</li> </ul>
		Occurs during descent (vertical axis).	<ul style="list-style-type: none"> <li>• Gravitational torque is too large.</li> </ul>	<ul style="list-style-type: none"> <li>• Add a counterbalance to the machine to lower gravitational torque.</li> <li>• Slow the descent speed.</li> <li>• Calculate the regenerative energy, and connect an External Regeneration Resistor with the required regeneration absorption capacity.</li> </ul>
		<ul style="list-style-type: none"> <li>• The operating limit of the External Regeneration Resistor is limited to 10%.</li> </ul>	<ul style="list-style-type: none"> <li>• Set Pn6C to 2. For details, refer to <i>Parameter Details</i> on page 5-32.</li> </ul>	
21	Encoder disconnection detected	Occurs during operation.	<ul style="list-style-type: none"> <li>• The encoder is disconnected.</li> <li>• Connector contacts are faulty.</li> </ul>	<ul style="list-style-type: none"> <li>• Fix the locations that are disconnected.</li> <li>• Correct the wiring.</li> </ul>
			<ul style="list-style-type: none"> <li>• The encoder wiring is incorrect.</li> </ul>	<ul style="list-style-type: none"> <li>• Correct the wiring.</li> </ul>
			<ul style="list-style-type: none"> <li>• The encoder is damaged.</li> </ul>	<ul style="list-style-type: none"> <li>• Replace the Servomotor.</li> </ul>
			<ul style="list-style-type: none"> <li>• The Servo Drive is faulty.</li> </ul>	<ul style="list-style-type: none"> <li>• Replace the Servo Drive.</li> </ul>
			<ul style="list-style-type: none"> <li>• The Servomotor is mechanically being held.</li> </ul>	<ul style="list-style-type: none"> <li>• If the Servomotor shaft is being held by external force, release it.</li> </ul>

## 8-3 Troubleshooting

Alarm code	Error	Status when error occurs	Cause	Countermeasure
23	Encoder data error	Occurs when the power supply is turned ON or during operation.	• The encoder signal wiring is incorrect.	• Correct the wiring.
			• Noise on the encoder wiring causes incorrect operation.	• Take measures against noise on the encoder wiring.
			• The power supply voltage for the encoder has dropped (especially when the cable is long.)	• Provide the required encoder power supply voltage (5 VDC±5%).
24	Deviation counter overflow	Occurs when the Servomotor does not rotate even when command pulses are input.	• The Servomotor power wiring or the encoder wiring is incorrect.	• Correct the wiring.
			• The Servomotor is mechanically being held.	• If the Servomotor shaft is held by external force, release it. • Release the electromagnetic brake.
			• Control PCB error.	• Replace the Servo Drive.
		Occurs during high-speed rotation.	• The Servomotor power wiring or the encoder wiring is incorrect.	• Correct the wiring.
		Occurs when long command pulses are given.	• Gain adjustment is insufficient.	• Adjust the gain.
			• The acceleration and deceleration are too rapid.	• Extend the acceleration and deceleration times.
			• The load is too large.	• Reduce the load. • Select a suitable Servomotor.
Occurs during operation.	• The setting for the Deviation Counter Overflow Level (Pn63) was exceeded.	• Increase the setting of Pn63. • Slow the rotation speed. • Reduce the load. • Extend the acceleration and deceleration times.		
26	Overspeed	Occurs during high-speed rotation.	• The speed command input is too large.	• Set the command pulse frequency to 500 kpps max.
			• The setting for the Electronic Gear Ratio Numerator (Pn46 or Pn47) is not appropriate.	• Set Pn46 and Pn47 so that the command pulse frequency is 500 kpps max.
			• The maximum number of rotations is exceeded due to overshooting.	• Adjust the gain. • Reduce the maximum command speed.
			• The encoder wiring is incorrect.	• Correct the wiring.
		Occurs when torque limit switching is used.	• The Overspeed Detection Level Setting (Pn70) or No. 2 Overspeed Detection Level Setting (Pn73) has been exceeded.	• If torque limit switching is used, correctly set the allowable operating speed for Pn70 and Pn73.



Alarm code	Error	Status when error occurs	Cause	Countermeasure
27	Electronic gear setting error	Occurs when command pulses are given.	<ul style="list-style-type: none"> <li>The setting for the Electronic Gear Ratio Numerator (Pn46 or Pn47) is not appropriate.</li> </ul>	<ul style="list-style-type: none"> <li>Set Pn46 and Pn47 so that the command pulse frequency is 500 kpps max.</li> </ul>
29	Deviation counter overflow	Occurs when the Servomotor does not rotate even if command pulses are input.	<ul style="list-style-type: none"> <li>The Servomotor power wiring or the encoder wiring is incorrect.</li> </ul>	<ul style="list-style-type: none"> <li>Correct the wiring.</li> </ul>
			<ul style="list-style-type: none"> <li>The Servomotor is mechanically being held.</li> </ul>	<ul style="list-style-type: none"> <li>If the Servomotor shaft is held by external force, release it.</li> <li>Release the electromagnetic brake.</li> </ul>
			<ul style="list-style-type: none"> <li>Control PCB error</li> </ul>	<ul style="list-style-type: none"> <li>Replace the Servo Drive.</li> </ul>
		Occurs during high-speed rotation.	<ul style="list-style-type: none"> <li>The Servomotor power wiring or the encoder wiring is incorrect.</li> </ul>	<ul style="list-style-type: none"> <li>Correct the wiring.</li> </ul>
		Occurs when long command pulses are given.	<ul style="list-style-type: none"> <li>Gain adjustment is insufficient.</li> </ul>	<ul style="list-style-type: none"> <li>Adjust the gain.</li> </ul>
			<ul style="list-style-type: none"> <li>The acceleration and deceleration are too rapid.</li> </ul>	<ul style="list-style-type: none"> <li>Extend the acceleration and deceleration times.</li> </ul>
<ul style="list-style-type: none"> <li>The load is too large.</li> </ul>	<ul style="list-style-type: none"> <li>Reduce the load.</li> <li>Select a suitable Servomotor.</li> </ul>			
34	Overrun limit error	Occurs during operation.	<ul style="list-style-type: none"> <li>The Overrun Limit Setting (Pn26) is exceeded during operation.</li> </ul>	<ul style="list-style-type: none"> <li>Adjust the gain.</li> <li>Increase the setting for Pn26.</li> <li>Set Pn26 to 0 to disable the function.</li> </ul>
36	Parameter error	Occurs when the power supply is turned ON.	<ul style="list-style-type: none"> <li>There are errors in the parameters that were read.</li> </ul>	<ul style="list-style-type: none"> <li>Reset all parameters.</li> </ul>
			<ul style="list-style-type: none"> <li>The Servo Drive is faulty.</li> </ul>	<ul style="list-style-type: none"> <li>Replace the Servo Drive.</li> </ul>
37	Parameter corruption	Occurs when the power supply is turned ON.	<ul style="list-style-type: none"> <li>The parameters that were read are corrupt.</li> </ul>	<ul style="list-style-type: none"> <li>Replace the Servo Drive.</li> </ul>
38	Drive prohibit input error	Occurs when the Servo is turned ON or during operation.	<ul style="list-style-type: none"> <li>The Forward Drive Prohibit Input (POT) and Reverse Drive Prohibit Input (NOT) were both OFF at the same time.</li> </ul>	<ul style="list-style-type: none"> <li>Correct the wiring.</li> <li>Replace the limit sensor.</li> <li>Check whether the power supply for control is input correctly.</li> <li>Check whether the setting for Drive Prohibit Input Selection (Pn04) is correct.</li> </ul>
48	Encoder phase Z error	Occurs during operation.	<ul style="list-style-type: none"> <li>A phase-Z pulse from the encoder was not detected regularly.</li> </ul>	<ul style="list-style-type: none"> <li>Replace the Servomotor.</li> </ul>
49	Encoder CS signal error	Occurs during operation.	<ul style="list-style-type: none"> <li>A logic error of the CS signal from the encoder was detected.</li> </ul>	<ul style="list-style-type: none"> <li>Replace the Servomotor.</li> </ul>

## 8-3 Troubleshooting

Alarm code	Error	Status when error occurs	Cause	Countermeasure
95	Servomotor non-conformity	Occurs when the power supply is turned ON.	• The Servomotor and Servo Drive combination is incorrect.	• Use a correct combination.
			• The encoder wiring is disconnected.	• Wire the encoder. • Fix the locations that are disconnected.
96	LSI setting error		• Incorrect operation due to noise.	• Take measures against noise.
Others	Other errors	---	• The Servo Drive's self-diagnosis function detected an error in the Servo Drive.	• Turn OFF the power supply and turn it ON again. • Replace the Servomotor or Servo Drive.

## Error Diagnosis Using the Operating Status

Symptom	Probable cause	Items to check	Countermeasures
The power LED indicator (PWR) does not light when the power supply is turned ON.	The power supply cable is wired incorrectly.	Check whether the power supply input is within the allowed voltage range.	Supply the correct voltage.
		Check whether the power supply input is wired correctly.	Correct the wiring.
The Servomotor does not rotate even if commands are input from the Controller.	The RUN Command Input is OFF.	Check whether the RUN signal is ON or OFF in monitor mode.	<ul style="list-style-type: none"> <li>• Turn ON the RUN Command Input.</li> <li>• Correct the wiring.</li> </ul>
	The Forward Drive Prohibit Input (POT) and Reverse Drive Prohibit Input (NOT) are OFF.	Check whether the POT input and NOT input are ON or OFF in monitor mode.	<ul style="list-style-type: none"> <li>• Turn ON the POT and NOT inputs.</li> <li>• If the POT and NOT inputs are not used, disabled them.</li> </ul>
	The control mode is not correct.	Check the Control Mode Selection (Pn02).	Set the control mode to match the command type.
	The Deviation Counter Reset Input (ECRST) is ON.	Check whether the ECRST Input is ON or OFF in monitor mode.	<ul style="list-style-type: none"> <li>• Turn the ECRST Input OFF.</li> <li>• Correct the wiring.</li> </ul>
	The Command Pulse Mode (Pn42) setting is incorrect.	Check the Controller's command pulse type and the Servo Drive's command pulse type.	Set the Servo Drive's pulse type to match the Controller's command pulse type.
	The Zero Speed Designation Input (VZERO) is OFF.	Check whether the VZERO Input is ON or OFF in monitor mode.	<ul style="list-style-type: none"> <li>• Turn ON the VZERO Input.</li> <li>• Correct the wiring.</li> </ul>
	The internally set speeds are not set.	Check the settings for Pn53 to Pn56.	Set the desired speeds.
	The Torque Limit (Pn5E) is set to 0.	Check the setting for Pn5E.	Return the setting to the default.
	The Servomotor Power Cable is wired incorrectly.	Check the wiring.	Wire correctly.
	The Encoder Cable is wired incorrectly.		
The control I/O connector (CN1) is wired incorrectly.	Check the command pulse's wiring.	Wire correctly.	
	Check the command pulse type.	Set the Servo Drive's pulse type to match the Controller's command pulse type.	
	Check the command pulse's voltage.	Connect a resistor that matches the voltage.	
The power supply is not ON.	Check whether the power supply is ON and check the PWR LED indicator.	Turn ON the power supply.	
	Check the voltage across the power supply terminals.	Wire the power supply's ON circuit correctly.	
The CW Input and CCW Input are ON at the same time.	Check the command pulse's wiring.	<ul style="list-style-type: none"> <li>• Input the pulse signal either to the CW Input or CCW Input.</li> <li>• Always turn OFF the terminal that is not input to.</li> </ul>	
Servo Drive is faulty.	---	Replace the Servo Drive.	

## 8-3 Troubleshooting

Symptom	Probable cause	Items to check	Countermeasures
The Servomotor operates momentarily, but it does not operate after that.	The Servomotor Power Cable is wired incorrectly.	Check the wiring of the Servomotor Power Cable's phases U, V, and W.	Wire correctly.
	The Encoder Cable is wired incorrectly.	Check the Encoder Cable's wiring.	Wire correctly.
The Servomotor rotates without a command.	The command pulse input is incorrect.	Check the command pulse type.	Set the command pulse input appropriately.
		Check the command pulse's voltage.	Connect a resistor that matches the voltage.
	The Servo Drive is faulty.	---	Replace the Servo Drive.
The Servomotor rotates in the opposite direction from the command.	The CW input and CCW input are connected reversely.	Check the Controller's command pulse type and the Servo Drive's command pulse type.	Connect the CW pulse signal to the CW Input and the CCW pulse signal to the CCW Input.
Servomotor rotation is unstable.	The Servomotor Power Cable or Encoder Cable is wired incorrectly.	Check the wiring of the Servomotor Power Cable's phases U, V, and W and check the Encoder Cable's wiring.	Wire correctly.
	The coupling system between the Servomotor shaft and the mechanical system has eccentricity and declination, loose screws, or the torque is fluctuating due to engagement between pulleys or gears.	Check the mechanical system's coupling section.	Review and adjust the machine.
		Try rotating the Servomotor without a load. (Disconnect it from the mechanical system.)	
	The load's moment of inertia exceeds the Servo Drive's allowable value.	Try rotating the Servomotor without a load. (Disconnect it from the mechanical system.)	<ul style="list-style-type: none"> <li>• Reduce the load.</li> <li>• Replace it with the Servomotor and Servo Drive with higher capacity.</li> </ul>
	The pulse signal line's connections failure.	Check the pulse signal wiring at the Controller and Servo Drive.	Wire correctly.
		Check the Controller's command pulse type and the Servo Drive's command pulse type.	Set the Servo Drive's pulse type to match the Controller's command pulse type.
	The gain doesn't match.	---	<ul style="list-style-type: none"> <li>• Use autotuning.</li> <li>• Perform manual tuning.</li> </ul>
	The CN1 input signal is chattering.	Check the RUN Command Input (RUN), Deviation Counter Reset Input (ECRST), Zero Speed Designation Input (VZERO), Internally set Speed Selection 1, 2 (VSEL1, VSEL2).	Correct the wiring so that there is no chattering.
The Servomotor is overheating.	The ambient temperature is too high.	Check that the ambient temperature around the Servomotor is below 40°C.	Lower the ambient temperature to 40°C or less. (Use a cooler or fan.)
	Ventilation is obstructed.	Check to see whether anything is blocking ventilation.	Improve ventilation.
	The Servomotor is overloaded.	Try rotating the Servomotor without a load. (Disconnect it from the mechanical system.)	<ul style="list-style-type: none"> <li>• Reduce the load.</li> <li>• Replace the Servomotor and Servo Drive with a Servomotor and Servo Drive with higher capacities.</li> </ul>
	The Servomotor is rotating with vibration.		

Symptom	Probable cause	Items to check	Countermeasures
The holding brake is ineffective.	Power is supplied to the holding brake.	Check whether power is supplied to the holding brake.	Configure a circuit that cuts power to the holding brake when the motor stops and the load is held by the holding brake.
The Servomotor doesn't stop or is hard to stop even if the RUN Command Input (RUN) is turned OFF while the Servomotor is rotating.	The load inertia is too large.	Check the following: <ul style="list-style-type: none"> <li>• Is the load too large?</li> <li>• Is the Servomotor speed too high?</li> </ul>	Re-evaluate the load conditions and replace the Servomotor/Servo Drive with an appropriate model if necessary.
	The stop circuit failed.	---	Replace the Servo Drive.
The Servomotor is producing unusual noises or the machine is vibrating. (Continued on next page.)	There are problems with the machine's installation.	Check whether the Servomotor's mounting screws are loose.	Tighten the mounting screws.
		Check whether the axes are misaligned in the mechanical coupling system.	Align the mechanical couplings.
		Check whether the coupling is unbalanced.	Adjust the coupling's balance.
	There is a problem with the bearings.	Check for noise or vibration around the bearings.	Contact your OMRON representative.
	The gain is doesn't match.	---	<ul style="list-style-type: none"> <li>• Use autotuning.</li> <li>• Perform manual tuning.</li> </ul>
	The Speed Feedback Filter Time Constant (Pn13) is wrong.	Check the setting of Pn13.	Return the setting to 4 (default) or increase the setting.
	Noise is entering the Control I/O Cable because the cable does not meet specifications.	Check that the cable wire is a twisted-pair wire or shielded twisted-pair cable with wires of at least 0.08 mm <sup>2</sup> .	Use the Control I/O Cable that meets specifications.
	Noise is entering the Control I/O Cable because the cable is longer than the specified length.	Check the length of the Control I/O Cable.	Shorten the Control I/O Cable to 3 m or less.
	Noise is entering the cable because the Encoder Cable does not meet specifications.	Check that the cable wires are twisted-pair wires or shielded twisted-pair wires that are at least 0.12 mm <sup>2</sup> .	Use the Encoder Cable that meets specifications.
	Noise is entering the Encoder Cable because the cable is longer than the specified length.	Check the length of the Encoder Cable.	Shorten the Encoder Cable to 20 m or less.
Noise is entering the signal wires because the Encoder Cable is stuck or the sheath is damaged.	Check whether the Encoder Cable is damaged.	Correct the Encoder Cable's pathway to prevent damage.	
Too much noise is entering the Encoder Cable.	Check whether the Encoder Cable is tied up in a bundle with or too close to high current lines.	Lay the Encoder Cable in a way surges are not applied.	

## 8-3 Troubleshooting

Symptom	Probable cause	Items to check	Countermeasures
The Servomotor is producing unusual noises or the machine is vibrating. (Continued from previous page.)	The FG's potential is fluctuating due to devices near the Servomotor, such as a welding machine.	Check for grounding problems (failure to ground or incomplete grounding) at devices such as a welding machine near the Servomotor.	Ground the equipment properly and prevent currents from flowing to the encoder FG.
	Errors are being caused by excessive vibration or shock on the encoder.	There are problems with mechanical vibration or motor installation (such as the mounting surface precision, attachment, or axial misalignment).	Reduce the mechanical vibration or correct the Servomotor's installation.
	The machine and the Servomotor are resonating.	Check whether the machine is resonating.	<ul style="list-style-type: none"> <li>• Readjust the Torque Command Filter Time Constant.</li> <li>• If there is resonance, set the Notch Filter 1 Frequency (Pn1D) and Notch Filter 1 Width (Pn1E).</li> </ul>
Vibration is occurring at the same frequency as the power supply.	Inductive noise is occurring.	Check whether the Servo Drive control signal lines are too long.	Shorten the control signal lines.
		Check whether control signal lines and power supply lines are bundled together.	<ul style="list-style-type: none"> <li>• Separate control signal lines from power supply lines.</li> <li>• Use a low-impedance power supply for control signals.</li> </ul>
The position is misaligned. (Position misalignment occurs without an alarm being output.)	There is an error in the coupling of the mechanical system and the Servomotor.	Check whether the coupling of the mechanical system and the Servomotor is misaligned.	Couple the mechanical system and the Servomotor correctly.
	Noise is entering the Deviation Counter Reset Input (ECRST).	Check whether the control signal lines and power supply lines are bundled together.	Take measures against noise, such as separating the control signal lines and power lines.
	The gain is does not match.	---	<ul style="list-style-type: none"> <li>• Use autotuning.</li> <li>• Perform manual tuning.</li> </ul>
	The load inertia is too large.	Check the following: <ul style="list-style-type: none"> <li>• Check whether the load is too large.</li> <li>• Check whether the rotation speed of the Servomotor is too high.</li> </ul>	<ul style="list-style-type: none"> <li>• Adjust the gain.</li> <li>• Review the load conditions, and replace the Servomotor and Servo Drive with appropriate models.</li> </ul>

# 8-4 Overload Characteristics (Electronic Thermal Function)

An overload protection (electronic thermal) function is built into the Servo Drive to protect the Servo Drive and Servomotor from overloading.

If an overload does occur, eliminate the cause of the error and then wait at least one minute for the Servomotor temperature to drop before turning on the power again.

If the power is turned ON again repeatedly at short intervals, the Servomotor windings may burn out.

## Overload Characteristics Graphs

The following graphs show the characteristics of the load rate and electronic thermal operating time.

### ■ R88M-G (Cylindrical Servomotor)

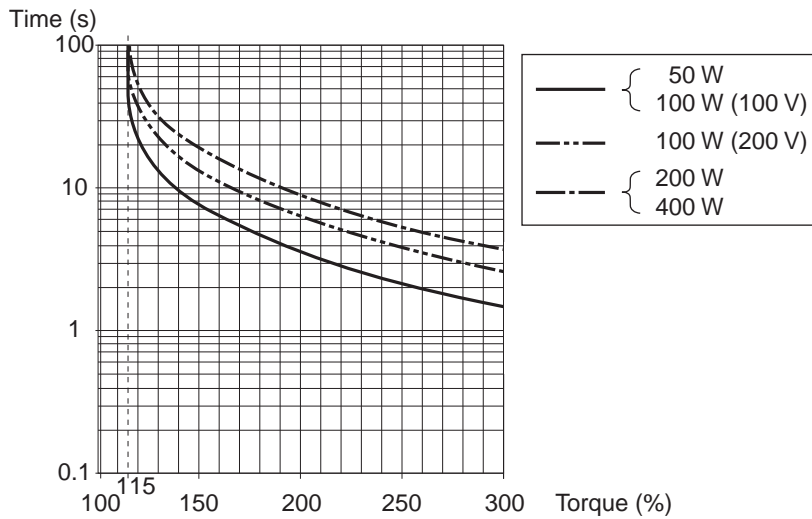

### ■ R88M-GP (Flat Servomotor)

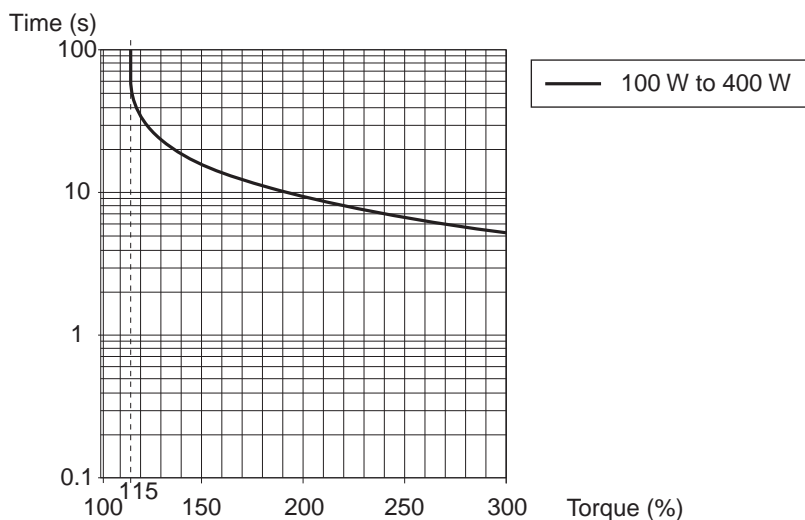

---

---

## 8-5 Periodic Maintenance



---

The Servomotor and Servo Drive contain many components and will function fully only when each of the individual components operates properly.

Some of the electrical and mechanical components require maintenance depending on application conditions. Periodic inspection and part replacement are necessary to ensure the proper long-term operation of the Servomotor and Servo Drive. (quotes from The Recommendation for Periodic Maintenance of a General-purpose Inverter published by JEMA)

The periodic maintenance cycle depends on the installation environment and application conditions of the Servomotor and Servo Drive.

Recommended maintenance times are listed below for reference in determining actual maintenance schedules.

 <b>Caution</b>	
	Resume operation only after transferring all data required for operation to the new Unit. Not doing so may result in damage to the product.
	Do not dismantle or repair the product. Doing so may result in electric shock or injury.

### Servomotor Service Life

The service life for components is listed below.

- ♦ Bearings: 20,000 hours
- ♦ Decelerator: 20,000 hours
- ♦ Oil seal: 5,000 hours
- ♦ Encoder: 30,000 hours

These values presume an ambient Servomotor operating temperature of 40°C, shaft loads within the allowable range, rated operation (rated torque and rated r/min), and install as described in this manual.

- ♦ The oil seal can be replaced.
- ♦ If timing pulleys are belt driven, the radial loads during operation (rotation) are as twice as the static loads. Consult with the belt and pulley manufacturers and adjust designs and system settings so that the Servomotor's allowable shaft load is not exceeded even during operation. If a Servomotor is used under a shaft load exceeding the allowable limit, the Servomotor shaft may break and the bearings may burn out.
- ♦ When requesting a repair or inspection, separate the Servomotor and Decelerator, and make a separate request for each product.



---

## Servo Drive Service Life

The service life of the Servo Drive is provided below.

Consult with your OMRON representative to determine whether or not components need to be replaced.

- ♦ Aluminum electrolytic capacitors: 50,000 hours, at an ambient Servo Drive operating temperature of 40°C, 80% of the rated operation output (rated torque), installed as described in this manual.
- ♦ Axial fan: 30,000 hours, at an ambient Servo Drive operating temperature of 40°C and an ambient humidity of 65% RH.
- ♦ When using the Servo Drive in continuous operation, use a fan or air conditioner to maintain an ambient operating temperature of 40°C or lower.
- ♦ We recommend that the ambient operating temperature be lowered and the power ON time be reduced as much as possible to lengthen the service life of the Servo Drive.
- ♦ The service life of aluminum electrolytic capacitors is greatly affected by the ambient operating temperature. Generally, an increase of 10°C in the ambient operating temperature will reduce the capacitor life by 50%.
- ♦ Aluminum electrolytic capacitors deteriorate even if the Servo Drive is stored with no power supplied. If the Servo Drive is not used for a long time, we recommend a periodic inspection and part replacement in five years.
- ♦ If the Servomotor or Servo Drive is not used for a long time, or if they are used under conditions worse than those described above, a periodic inspection of five years is recommended.



# Appendix

Connection Examples ..... Appendix-1

# Appendix Connection Examples

## ■ Connection Example 1: Connecting to SYSMAC CJ1W-NC133/233/433 Position Control Units

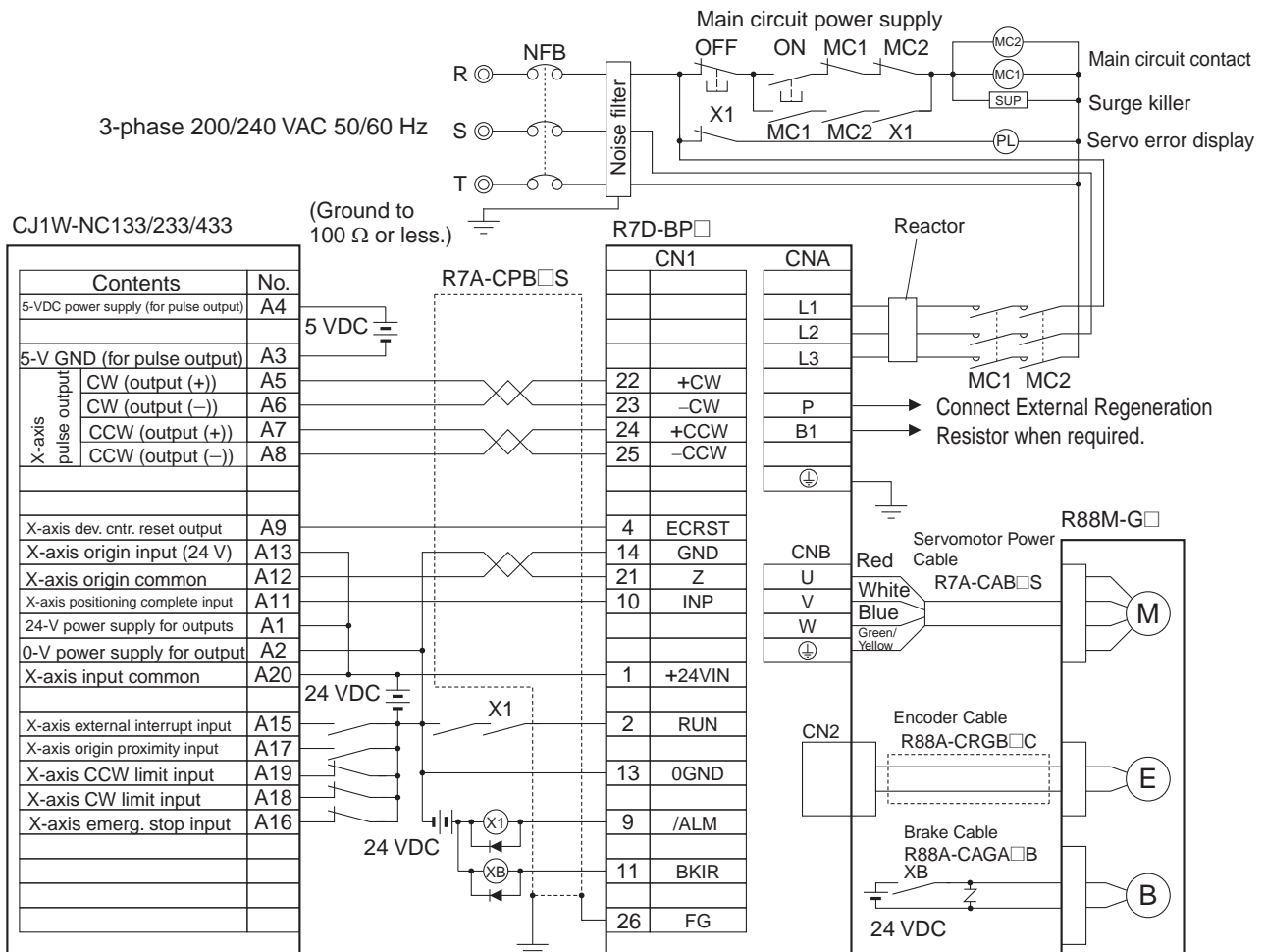

### Precautions for Correct Use

- ◆ Incorrect signal wiring can cause damage to Units and the Servo Drive.
- ◆ Leave unused signal lines open and do not wire them.
- ◆ Use mode 2 for origin search.
- ◆ Use the 5-VDC power supply for the command pulse inputs as a dedicated power supply.
- ◆ Do not share the power supply for brakes (24 VDC) with the 24-VDC power supply for controls.
- ◆ Recommended surge absorption diode: RU2 (Sanken Electric) or the equivalent

## ■ Connection Example 2: Connecting to SYSMAC CJ1W-NC113/213/413 Position Control Units

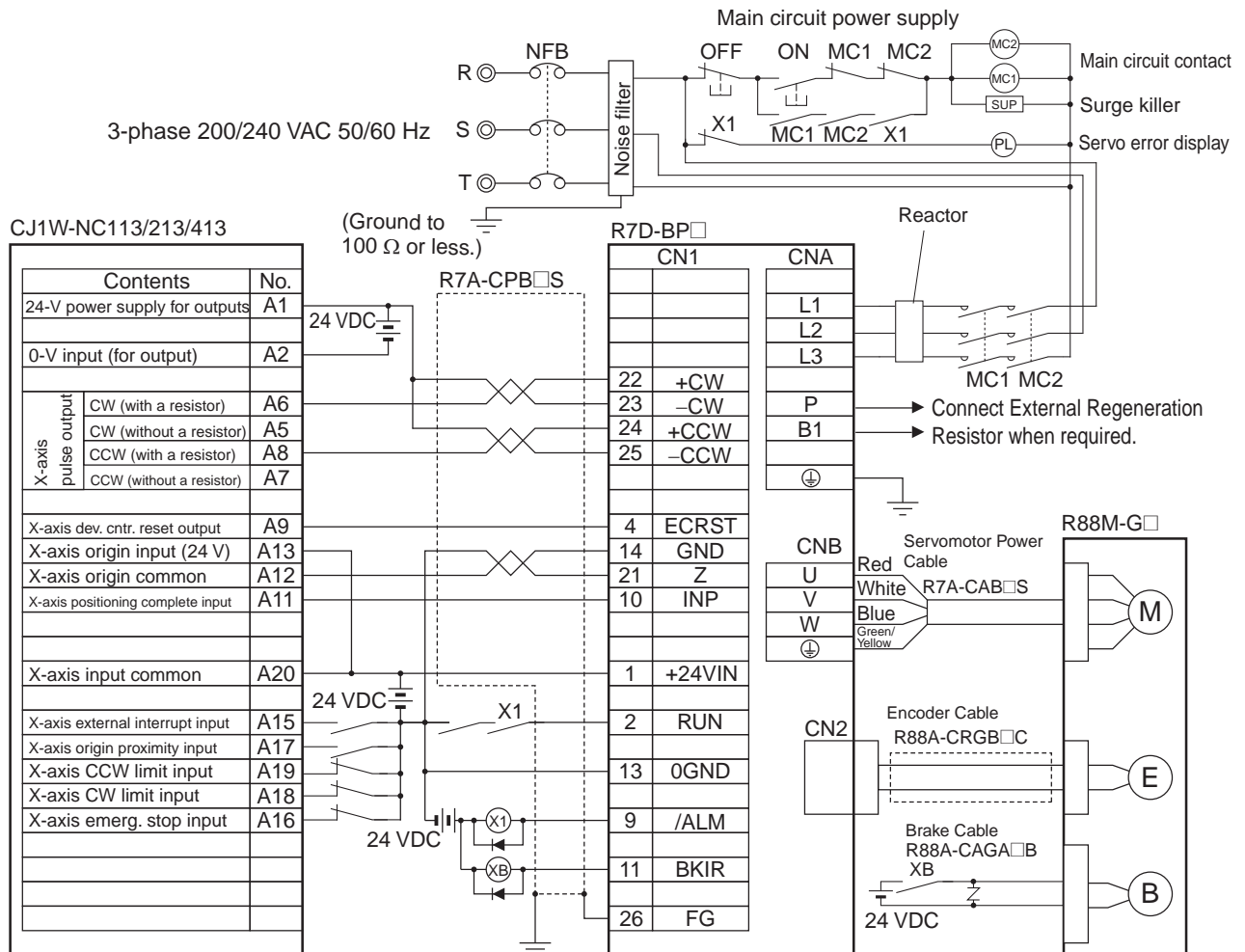

### Precautions for Correct Use

- ◆ Incorrect signal wiring can cause damage to Units and the Servo Drive.
- ◆ Leave unused signal lines open and do not wire them.
- ◆ Use mode 2 for origin search.
- ◆ Use the 24-VDC power supply for the command pulse inputs as a dedicated power supply.
- ◆ Do not share the power supply for brakes (24 VDC) with the 24-VDC power supply for controls.
- ◆ Recommended surge absorption diode: RU2 (Sanken Electric) or the equivalent

## ■ Connection Example 3: Connecting to SYSMAC CS1W-NC133/233/433 Position Control Units

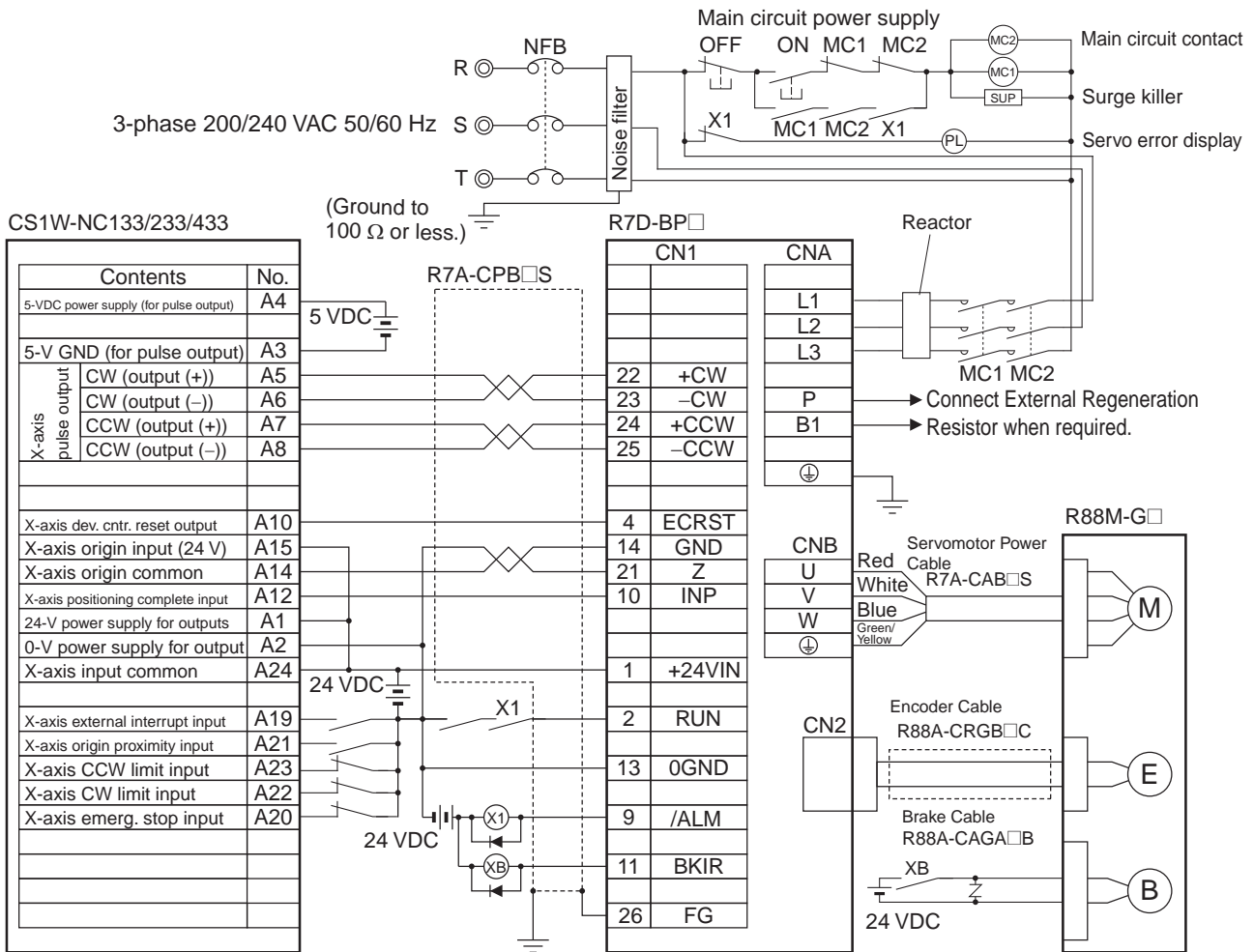

### Precautions for Correct Use

- ◆ Incorrect signal wiring can cause damage to Units and the Servo Drive.
- ◆ Leave unused signal lines open and do not wire them.
- ◆ Use mode 2 for origin search.
- ◆ Use the 5-VDC power supply for the command pulse inputs as a dedicated power supply.
- ◆ Do not share the power supply for brakes (24 VDC) with the 24-VDC power supply for controls.
- ◆ Recommended surge absorption diode: RU2 (Sanken Electric) or the equivalent

## ■ Connection Example 4: Connecting to SYSMAC CS1W-NC113/213/413, C200HW-NC113/213/413 Position Control Units

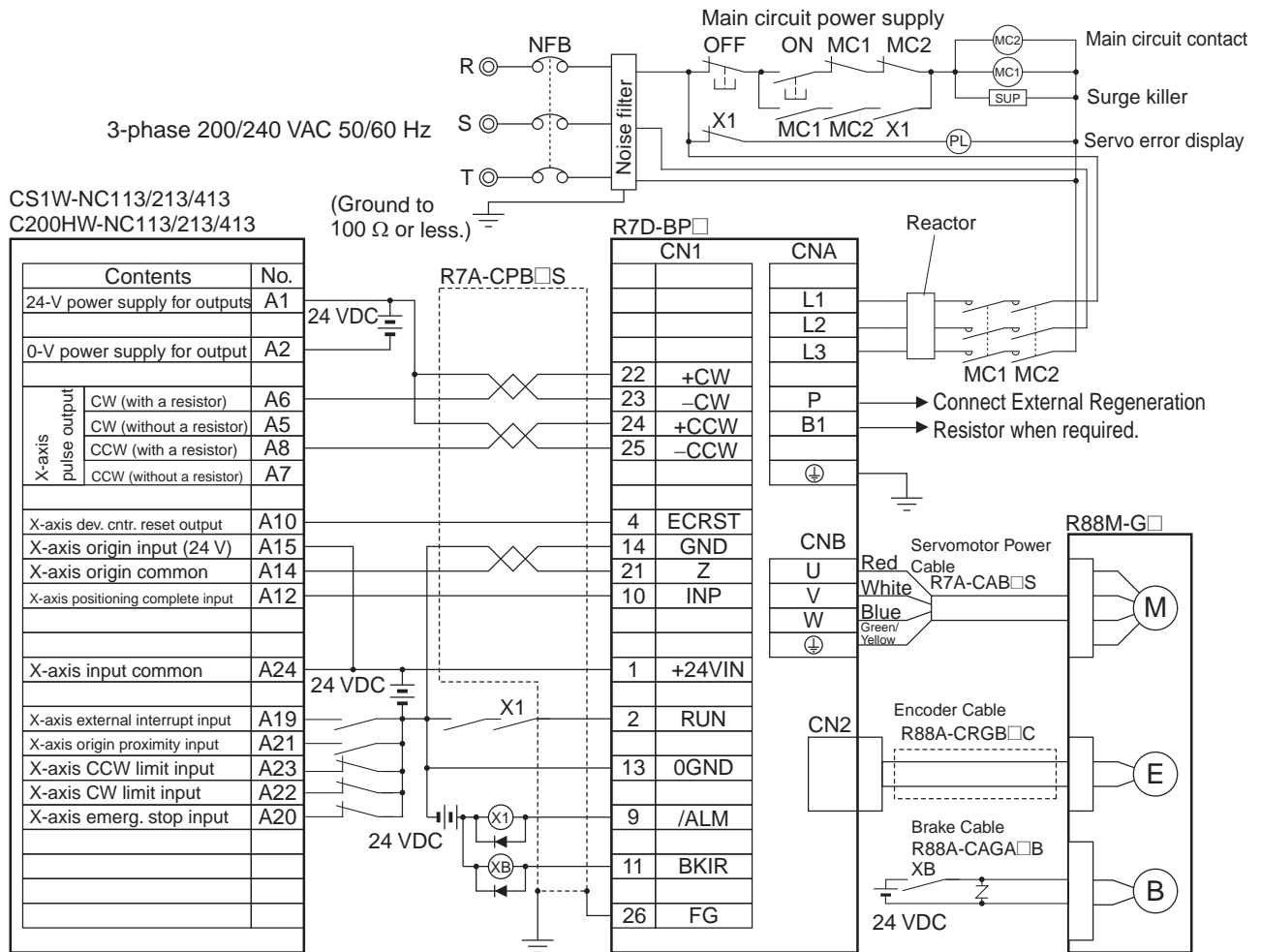

### Precautions for Correct Use

- ◆ Incorrect signal wiring can cause damage to Units and the Servo Drive.
- ◆ Leave unused signal lines open and do not wire them.
- ◆ Use mode 2 for origin search.
- ◆ Use the 24-VDC power supply for the command pulse inputs as a dedicated power supply.
- ◆ Do not share the power supply for brakes (24 VDC) with the 24-VDC power supply for controls.
- ◆ Recommended surge absorption diode: RU2 (Sanken Electric) or the equivalent

## ■ Connection Example 5: Connecting to SYSMAC CP1H-Y20DT-D

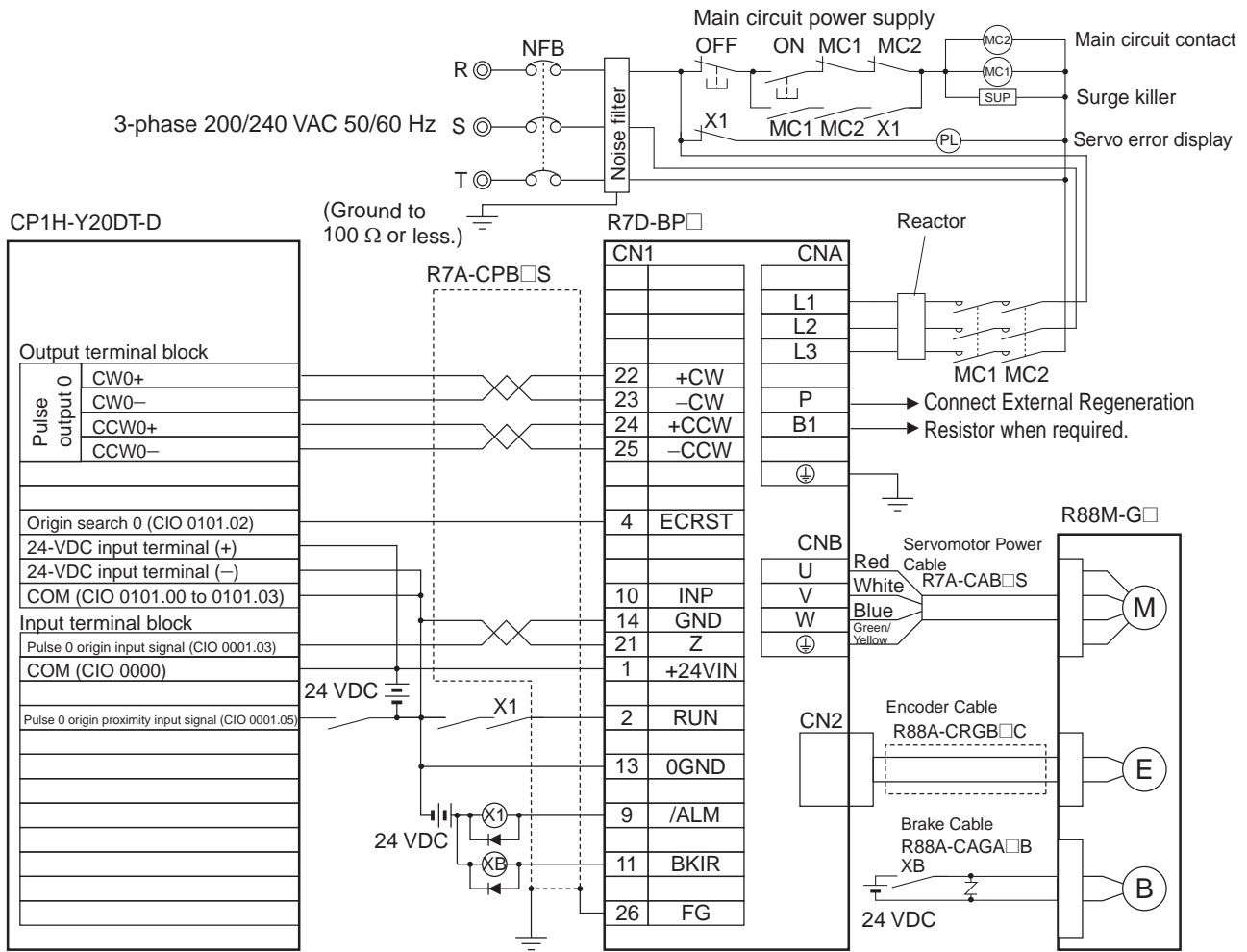

### Precautions for Correct Use

- ◆ Incorrect signal wiring can cause damage to Units and the Servo Drive.
- ◆ Leave unused signal lines open and do not wire them.
- ◆ Do not share the power supply for brakes (24 VDC) with the 24-VDC power supply for controls.
- ◆ Recommended surge absorption diode: RU2 (Sanken Electric) or the equivalent



■ Connection Example 6: Connecting to SYSMAC CP1H-X40DT-D/CP1L-□□□DT-□

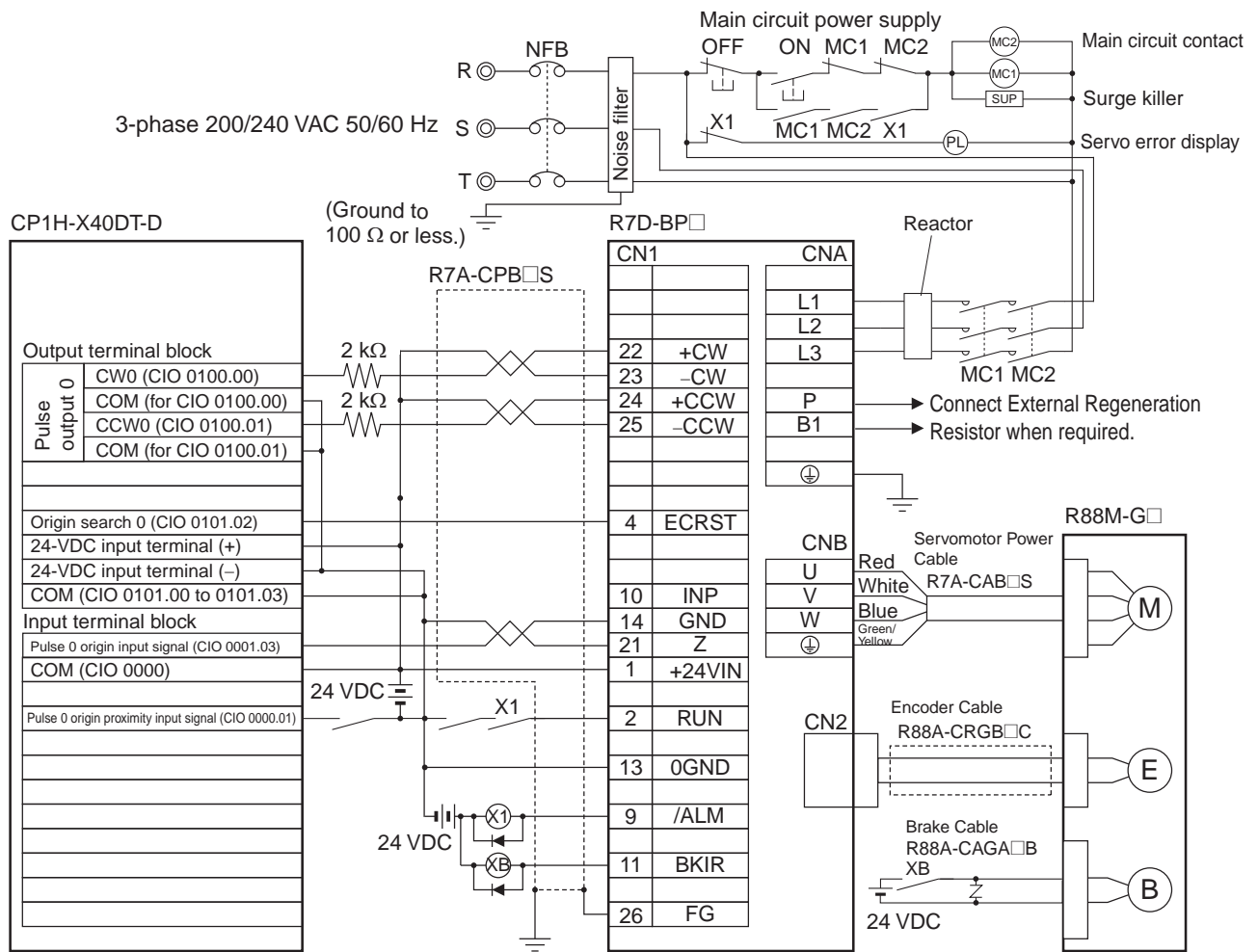

**Precautions for Correct Use**

- ◆ Incorrect signal wiring can cause damage to Units and the Servo Drive.
- ◆ Leave unused signal lines open and do not wire them.
- ◆ Do not share the power supply for brakes (24 VDC) with the 24-VDC power supply for controls.
- ◆ Recommended surge absorption diode: RU2 (Sanken Electric) or the equivalent

## ■ Connection Example 7: Connecting to SYSMAC CJ1M

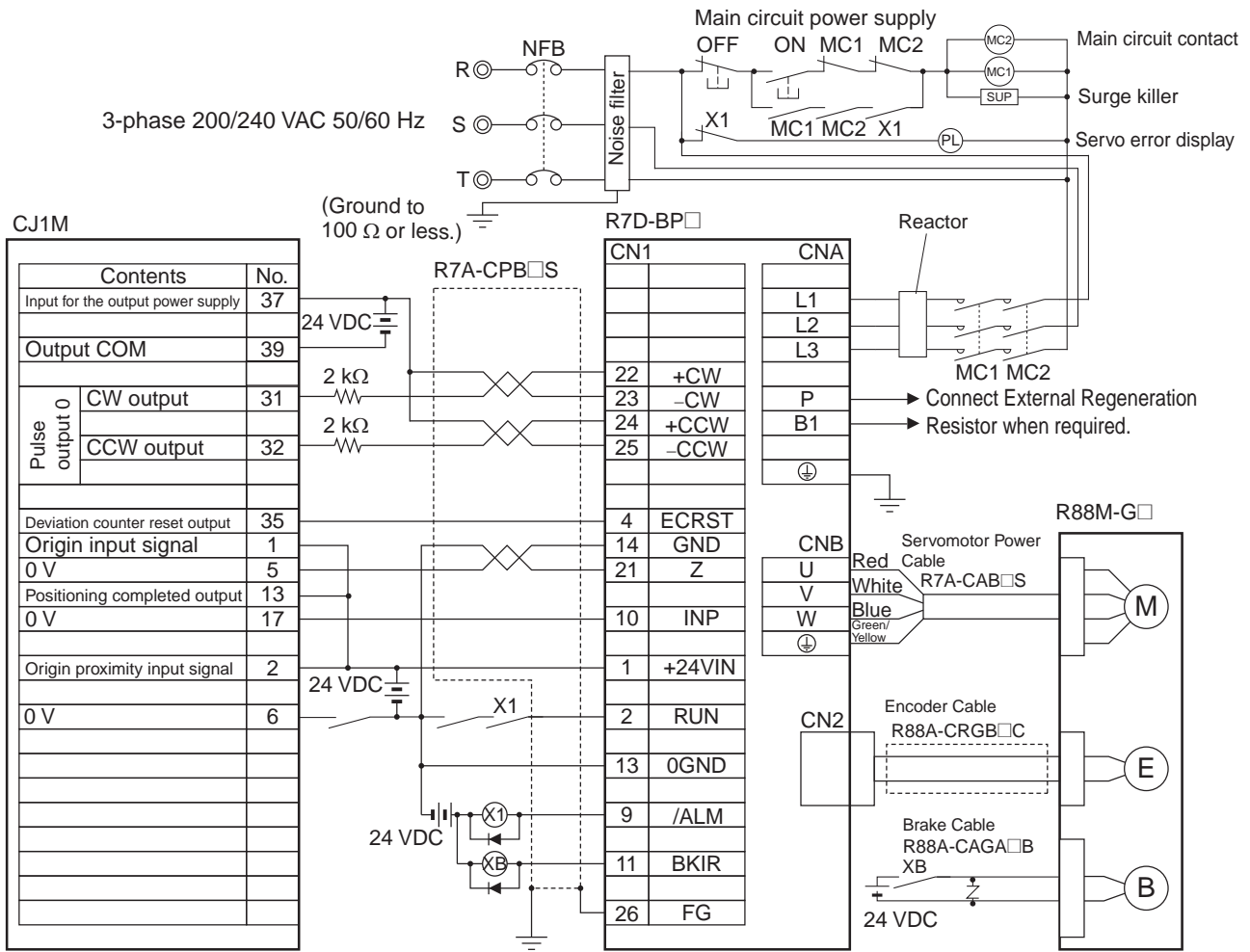

### Precautions for Correct Use

- ◆ Incorrect signal wiring can cause damage to Units and the Servo Drive.
- ◆ Leave unused signal lines open and do not wire them.
- ◆ Use mode 2 for origin search.
- ◆ Use the 24-VDC power supply for the command pulse inputs as a dedicated power supply.
- ◆ Do not share the power supply for brakes (24 VDC) with the 24-VDC power supply for controls.
- ◆ Recommended surge absorption diode: RU2 (Sanken Electric) or the equivalent

## ■ Connection Example 8: Connecting to FQM1-MMP21 Flexible Motion Controller

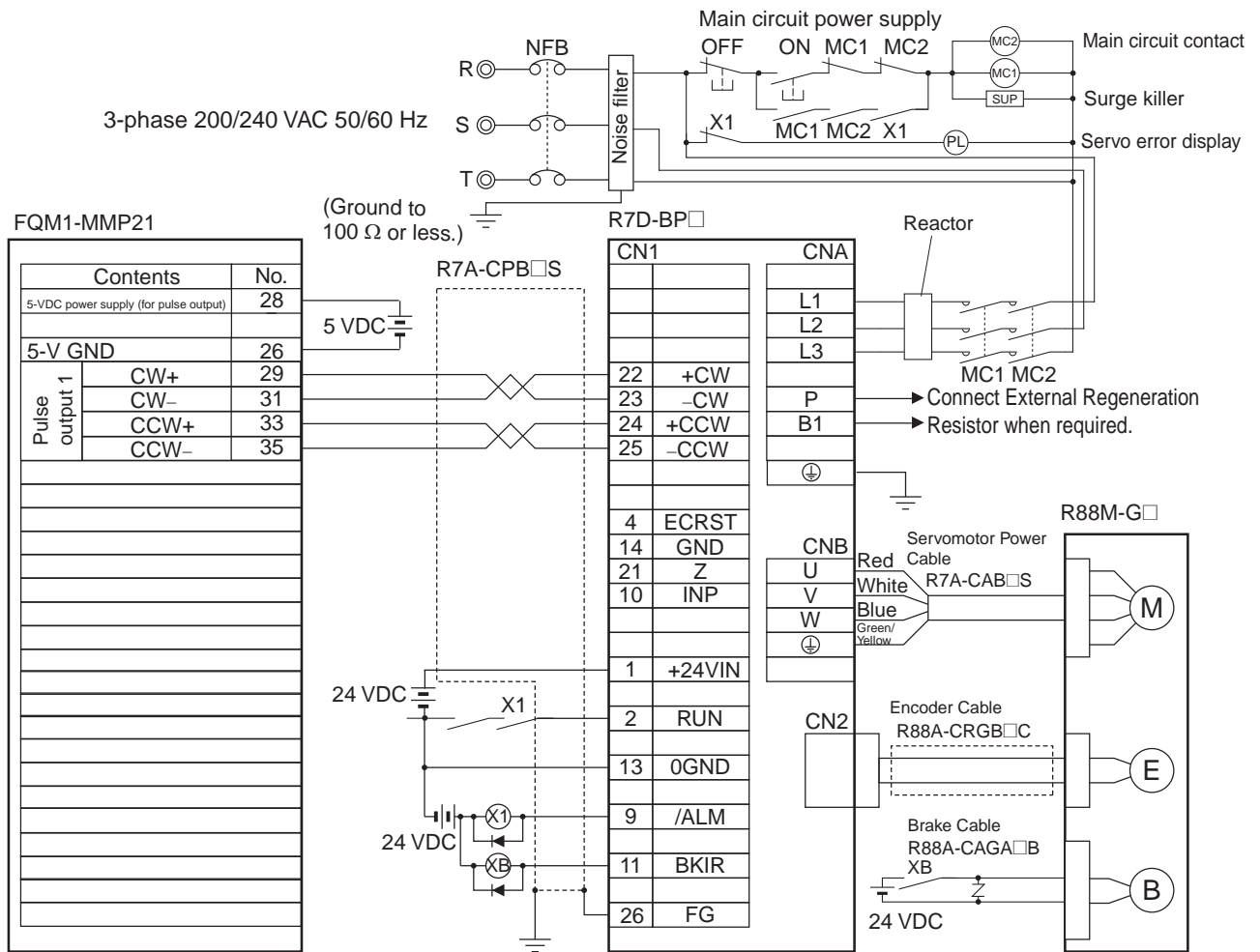

### Precautions for Correct Use

- ◆ Incorrect signal wiring can cause damage to Units and the Servo Drive.
- ◆ Leave unused signal lines open and do not wire them.
- ◆ Use the 24-VDC power supply for the command pulse inputs as a dedicated power supply.
- ◆ Do not share the power supply for brakes (24 VDC) with the 24-VDC power supply for controls.
- ◆ Recommended surge absorption diode: RU2 (Sanken Electric) or the equivalent





# Index

## Numerics

- 3,000-r/min Flat Servomotors ..... 2-2
- 3,000-r/min Servomotors ..... 2-1
- 90-degree Phase Difference Signal..... 3-11

## A

- adaptive filter ..... 7-5, 7-14
- alarm LED indicator ..... 1-4
- alarm output..... 3-13, 6-2
- alarm reset input..... 3-9
- ALM ..... 3-13, 6-2
- applicable load inertia ..... 3-25
- autotuning..... 7-8

## B

- BKIR ..... 3-14, 5-58, 5-59
- Brake Cables ..... 2-8
- Brake Interlock..... 3-14, 5-58, 5-59

## C

- CCW ..... 3-11
- clamp cores ..... 4-25
- Connector-Terminal Block Cables..... 2-11, 3-46, 4-12
- Connector-Terminal Block Conversion Unit ..... 3-47
- Connector-Terminal Block Conversion Units.. 2-12, 4-12
- contactors ..... 4-27
- Control I/O Connectors..... 2-9, 3-41
- Copy Mode ..... 6-20
- CW..... 3-11

## D

- damping control ..... 7-23
- Decelerators
  - backlash = 15 arcminutes max. .... 2-6
    - Cylindrical Servomotors ..... 2-6
    - dimensions ..... 2-23
    - specifications ..... 3-28
  - Flat Servomotors ..... 2-7
    - dimensions ..... 2-25
    - specifications ..... 3-29
  - installation ..... 4-7
  - backlash = 3 arcminutes max. .... 2-4
    - Cylindrical Servomotors ..... 2-4
      - dimensions ..... 2-19
      - specifications ..... 3-26
    - Flat Servomotors ..... 2-5
      - dimensions ..... 2-21
      - specifications ..... 3-27
    - installation ..... 4-5
- Deviation Counter Reset Input ..... 3-9
- DIN Rail Mounting Unit..... 2-12
  - dimensions..... 2-29
- Direction Signal ..... 3-11

## E

- EC Directives..... 1-6
- ECRST ..... 3-9
- electronic gear ..... 5-9, 5-50

- Electronic Gear Switch ..... 3-10
- EMC Directives..... 4-17
- Encoder Cables ..... 2-8, 3-30, 4-28
- Encoder Connectors..... 3-15
- encoder dividing ..... 5-8, 5-49
- Encoder Input Connector (CN2) ..... 2-9
- encoder specifications ..... 3-25
- External Regeneration Resistor Connection Cables 3-38
- External Regeneration Resistors..... 2-12, 2-27, 4-34
  - dimensions..... 2-27
  - specifications ..... 3-78

## F

- Feed Pulse ..... 3-11
- feedback output..... 3-14
- Forward Drive Prohibit Input..... 3-11, 5-33
- Forward Pulse ..... 3-11

## G

- Gain Switch ..... 3-10
- General-purpose Control Cables..... 2-11, 3-44, 4-12
- GESEL..... 3-10
- GSEL ..... 3-10

## I

- INP..... 3-13, 5-55
- internally set speed control..... 5-4
- Internally Set Speed Selection 1 ..... 3-10
- Internally Set Speed Selection 2 ..... 3-9

## J

- jog operation..... 6-19

## L

- leakage breakers ..... 4-22

## M

- Main Circuit Connector ..... 2-9, 3-3, 3-40
- motor rotation directions ..... 3-16

## N

- NFB ..... 4-21
- noise filters for power supply input ..... 4-24, 4-30
- noise filters for Servomotor output..... 4-30
- noise resistance..... 4-29
- non-fuse breakers..... 4-21
- NOT ..... 3-11, 5-33
- notch filters ..... 7-21

## O

- oil seal ..... 4-4
- overrun limit ..... 5-16, 5-41

## P

Parameter Unit .....	2-2, 3-77, 6-4
dimensions .....	2-18
specifications .....	3-77
Personal Computer Monitor Cables .....	2-9, 3-39
phase-Z output .....	3-14
position control .....	5-1
Positioning Completed Output .....	3-13, 5-55
POT .....	3-11, 5-33
Power Cables	
specifications .....	3-36
single-phase .....	3-36
three-phase .....	3-37
Power Supply Cables .....	2-9, 4-10
power supply LED indicator .....	1-4
PULS .....	3-11
PWR .....	1-4

## R

R7A-CMB01A .....	3-3
R7A-CNB01A .....	3-41
R7A-CNB01P .....	3-3, 3-40
radio noise filters .....	4-25
Reactors .....	2-12
dimensions .....	2-28
specifications .....	3-79
realtime autotuning .....	7-3
regenerative energy .....	4-32
RESET .....	3-9
Reverse Drive Prohibit Input .....	3-11, 5-33
Reverse Pulse .....	3-11
Robot Cables for Brakes .....	4-10
Robot Cables for Encoders .....	4-10
Robot Cables for Servomotor Power .....	4-10
RUN .....	3-9
RUN Command Input .....	3-9

## S

Servo Drives .....	2-1
characteristics .....	3-2
dimensions .....	2-13
general specifications .....	3-1
Servo Relay Units .....	2-10, 4-11
Position Control Unit Cables .....	2-11
specifications .....	3-65
Servo Drive Cables .....	2-10
specifications .....	3-62, 3-64
Servomotor Connectors .....	2-9, 3-3, 3-41
Servomotor Power Cables .....	2-8
specifications .....	3-32
Servomotor Rotation Speed Detection Output .....	3-13, 5-56
Servomotors .....	2-1
3,000-r/min Flat Servomotors	
characteristics .....	3-19
dimensions .....	2-17
torque and rotation speed characteristics .....	3-22
3,000-r/min Servomotors	
characteristics .....	3-17
dimensions .....	2-15
torque and rotation speed characteristics .....	3-21
general specifications .....	3-16
SIGN .....	3-11
Standard Cables for Brakes .....	4-10

Standard Cables for Encoders .....	4-10
Standard Cables for Servomotor Power .....	4-10
surge absorbers .....	4-23
surge suppressors .....	4-27

## T

TGON .....	3-13, 5-56
TLSEL .....	3-10
torque limit .....	5-15, 5-54
Torque Limit Switch .....	3-10

## U

UL standards .....	1-6
--------------------	-----

## V

VSEL1 .....	3-10
VSEL2 .....	3-9
VZERO .....	3-10, 5-4

## W

WARN .....	3-14, 5-34
warning output .....	3-14, 5-34

## X

XW2B-20J6-1B .....	3-52
XW2B-20J6-3B .....	3-54
XW2B-20J6-8A .....	3-55
XW2B-40J6-2B .....	3-53
XW2B-40J6-9A .....	3-57
XW2B-80J7-12A .....	3-58
XW2Z- J-A10 .....	3-68
XW2Z- J-A11 .....	3-69
XW2Z- J-A14 .....	3-70
XW2Z- J-A15 .....	3-71
XW2Z- J-A18 .....	3-72
XW2Z- J-A19 .....	3-73
XW2Z- J-A28 .....	3-75
XW2Z- J-A3 .....	3-65
XW2Z- J-A30 .....	3-76
XW2Z- J-A33 .....	3-74
XW2Z- J-A6 .....	3-66
XW2Z- J-A7 .....	3-67
XW2Z- J-B29 .....	3-62
XW2Z- J-B30 .....	3-63
XW2Z- J-B32 .....	3-64

## Z

Zero Speed Designation .....	3-10, 5-4
------------------------------	-----------

---

## Revision History

A manual revision code appears as a suffix to the catalog number on the front and back covers of the manual.

Cat. No. I561-E1-02



Revision code

The following table outlines the changes made to the manual during each revision. Page numbers refer to the previous version.

Revision code	Date	Revised content
01	January 2008	Original production
02	July 2008	<b>Pages 3-26, 3-27, 3-28:</b> Changes made to decelerator specifications <b>Pages 2-8, 3-31, 3-33, 3-35, 4-10:</b> Robot cables added. <b>Pages 1-4, 1-5, 2-9, 2-13, 2-17, 2-19, 2-23, 2-25, 2-28, 3-4, 3-8, 3-11, 3-12, 3-16, 3-24, 3-25, 3-30, 3-31, 3-36, 3-37, 3-39, 3-41, 3-42, 3-50, 3-53, 3-55, 3-57, 3-59, 3-77, 3-78, 4-13, 4-14, 4-18, 4-25, 4-28, 4-29, 4-35, 5-1, 5-3, 5-6, 5-14, 5-58, 6-1, 6-7, 6-10, 6-11, 6-13, 7-10, 7-11, 7-15, A-1, A-2, A-3, A-4, A-5, A-6, A-7, A-8, A-9:</b> Minor changes





**OMRON Corporation**  
**Industrial Automation Company**  
**Control Devices Division H.Q.**  
**Motion Control Department**

Shiokoji Horikawa, Shimogyo-ku,  
Kyoto, 600-8530 Japan  
Tel: (81) 75-344-7173/Fax: (81) 75-344-7149  
2-2-1 Nishikusatsu, Kusatsu-shi,  
Shiga, 525-0035 Japan  
Tel: (81) 77-565-5223/Fax: (81) 77-565-5568

**Regional Headquarters**

**OMRON EUROPE B.V.**

Wegalaan 67-69-2132 JD Hoofddorp  
The Netherlands  
Tel: (31)2356-81-300/Fax: (31)2356-81-388

OMRON Industrial Automation Global: [www.ia.omron.com](http://www.ia.omron.com)

**OMRON ELECTRONICS LLC**

One Commerce Drive Schaumburg,  
IL 60173-5302 U.S.A.  
Tel: (1) 847-843-7900/Fax: (1) 847-843-7787

**OMRON ASIA PACIFIC PTE. LTD.**

No. 438A Alexandra Road # 05-05/08 (Lobby 2),  
Alexandra Technopark, Singapore 119967  
Tel: (65) 6835-3011/Fax: (65) 6835-2711

**OMRON (CHINA) CO., LTD.**

Room 2211, Bank of China Tower,  
200 Yin Cheng Zhong Road,  
PuDong New Area, Shanghai, 200120, China  
Tel: (86) 21-5037-2222/Fax: (86) 21-5037-2200

**Authorized Distributor:**

© OMRON Corporation 2008 All Rights Reserved.  
In the interest of product improvement,  
specifications are subject to change without notice.

**Cat. No. I561-E1-02**