

# TYPE JX-A

## Model X200 Series Inverter



### INSTRUCTION MANUAL

Thank you for purchasing JX inverter.

To ensure safe operation, please be sure to read the safety precautions provided in this document along with all of the user manuals for the inverter. Please be sure you are using the most recent versions of the user manuals. Keep this instruction manual and all of the manuals in a safe location and be sure that they are readily available to the final user of the products.

Name	Cat. No.
JX Series User's Manual	I567-E1-01

OMRON Corporation

NT305X-1

### Names of Parts

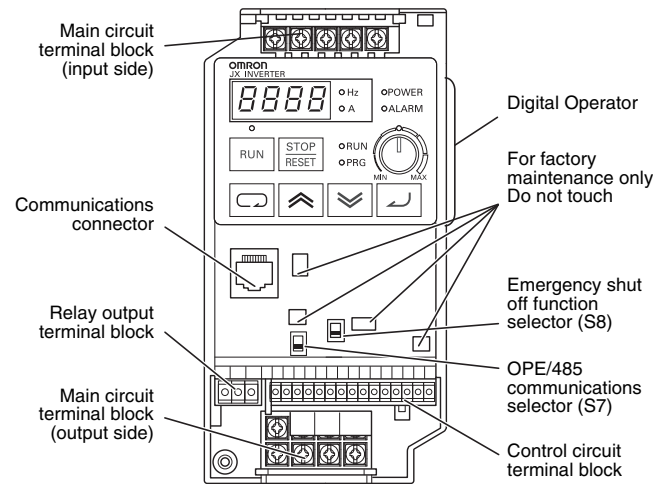

### Installation and Wiring

#### Dimensions

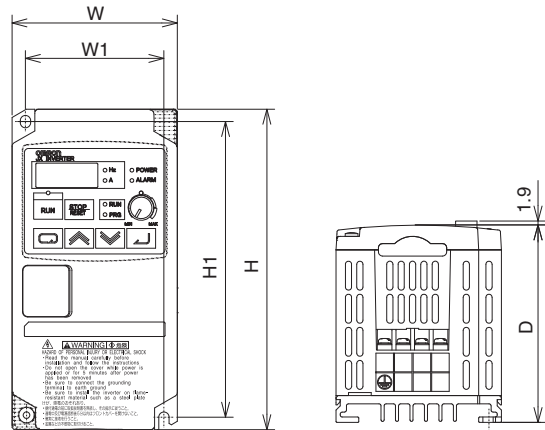

JX-	W	W1	H	H1	D
A2002-E, AB002-EF	80	67	155	143	95.5
A2004-E, AB004-EF					109.5
A2007-E					132.5
A4004-EF, AB007-EF	110	98	189	176	130.5
A2015-E, A2022-E, A2037-E, A4007-EF, A4015-EF, A4022-EF, A4040-EF, AB015-EF, AB022-EF					157.5
A2055-E, A2075-E, A4055-EF, A4075-EF					167.5

[mm]

### Standard Connection Diagram

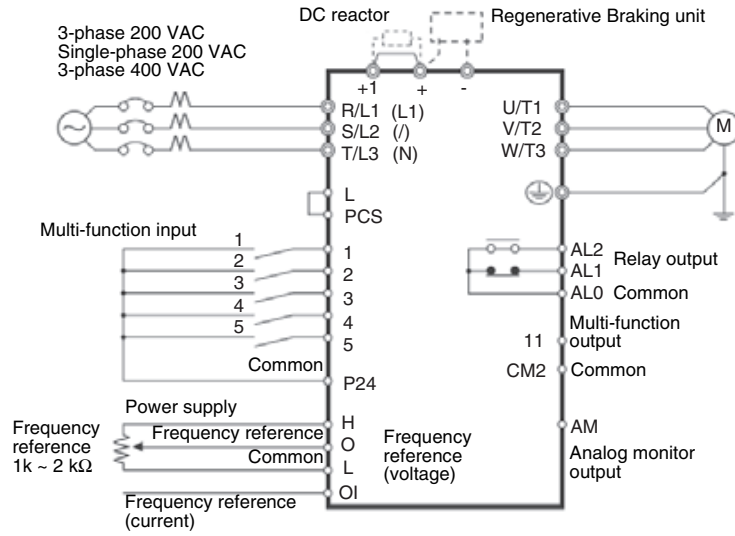

- \* Connect a single-phase 200 VAC input to terminals L1 and N.
- \* Factory default settings for relay output are NC contact for AL1 and NO contact for AL2.

### Terminal symbols, Screw size and Tightening Torque

Type	Terminal symbol	A2002 to A2007 AB002 to AB004	A2015 to A2037 A4004 to A4037 AB007 to AB022	A2055 to A2075 A4055 to A4075
Main circuit	R/L1, S/L2, T/L3 U/T1, V/T2, W/T3 Ground (symbol)	M3.5 0.8 N·m (max. 0.9 N·m)	M4 1.2 N·m (max. 1.3 N·m)	M5 3.0 N·m (max. 3.3 N·m)
Option	-, +, +1			
Control circuit	AM, H, O, OI, L 5, 4, 3, 2, 1, L, PCS, P24, CM2, 11	M2 / 0.2 N·m (max. 0.25 N·m)		
Relay	AL0, AL1, AL2	M2.5 / 0.5 N·m (max. 0.6 N·m)		
Ground	—	M4		M5

\* For AB□□□, L1, /, N are indicated instead R/L1, S/L2, T/L3 respectively.

### Keys

Name	Description
	Mode key Switches between the command setting and the data settings, and between the basic function mode and the expended function mode.  <b>Status transition</b>  * Hold down the Mode key for 3 seconds to jump to 'd001'.
	Increment key Changes the set values, parameters and Commands.
	Decrement key
	RUN key Starts the operation. Forward/Reverse rotation depends on the 'F004' setting.
	STOP/RESET key Stops the operation. Functions as the Reset key if an error occurs.
	Enter key Enters and stores the data.

### Parameter List

Parameter No.	Function name	Monitor or data range
d001	Output frequency monitor	0.0 to 400.0
d002	Output current monitor	0.0 to 999.9
d003	Rotation direction monitor	F:forward/o:stop/r:reverse
d004	PID feedback value monitor	0.00 to 9999 (Valid when the PID function is selected.)
d007	Output frequency monitor (after conversion)	0.00 to 9999 1000 to 3996 (at 10000 to 39960) (Output frequency × conversion factor of b086)
d013	Output voltage monitor	0 to 600
d016	Total RUN time	0 to 9999
d017	Power ON time monitor	0 to 9999
d018	Fin temperature monitor	0.0 to 200.0
d080	Fault frequency monitor	0 to 9999
d081	Fault monitor 1 (latest)	Error code (condition of occurrence) →
d082	Fault monitor 2	Output frequency → Output current →
d083	Fault monitor 3	Internal DC voltage → RUN time → ON time
d102	DC voltage monitor	0.0 to 999.9
d104	Electric thermal monitor	0.0 to 100.0
F001	Output frequency setting / monitor	Starting frequency to max. frequency
F002/F202	Acceleration time1/2nd acceleration time1	0.01 to 3000
F003/F203	Deceleration time1/2nd deceleration time1	0.01 to 3000
F004	Operator rotation direction selection	00:forward/01:reverse
A001/A201	Frequency reference selection/2nd frequency reference selection	00:Digital Operator (volume)/01:Terminal/ 02:Digital Operator (F001)/ 03:Modbus communication/ 10:Frequency operation result
A002/A202	RUN command selection/2nd RUN command selection	01:Terminal/02:Digital Operator/ 03:Modbus communication
A003/A203	Base frequency/ 2nd base frequency	30 to max. frequency [A004/A204]
A004/A204	Maximum frequency/ 2nd maximum frequency	30 to 400
A005	O/OI selection	02: Switch between O/Volume via terminal AT 03: Switch between OI/Volume via terminal AT 04: O input only/05:OI input only
A020/A220	Multi-step speed reference0/2nd multi-step speed reference0	0.0/Starting frequency to max. frequency
A021 to A035	Multi-step speed reference1~15	0.0/Starting frequency to max. frequency
A038	Jogging frequency	0.00/Strating frequency to 9.99
A039	Jogging stop selection	00:Free run on jogging stop 01:Deceleration stop on jogging stop 02:DC injection braking on jogging stop
A045/A245	Output voltage gain/ 2nd output voltage gain	20 to 100
A097	Acceleration pattern selection	00:Line/01:S-shape curve
A098	Deceleration pattern selection	
b001	Retry selection	00: Alarm/01:0 Hz start 02: Frequency matching start 03: Trip after frequency matching deceleration stop
b002	Allowable momentary power interruption time	0.3 to 25.0
b083	Carrier frequency	2.0 to 12.0
b084	Initialization selection	00:Clear the trip monitor 01:Initialize data 02:Clear and initialize
b130	Overvoltage LAD stop function	00:Disable/01:Enable
b131	Overvoltage LAD stop function level	200V class:330 to 395 400V class:660 to 790

Parameter No.	Function name	Monitor or data range
C001/C201	Multi-function input1 selection/2nd multi-function input1 selection	00:FW(forward)/01:RV(reverse)/ 02:CF1(multi-step speed setting binary1)/ 03:CF2(multi-step speed setting binary2)/ 04:CF3(multi-step speed setting binary3)/ 05:CF4(multi-step speed setting binary4)/ 06:JG(jogging)/07:DB(external DC injection/braking)/08:SET(2nd control)/09:2CH(2-step acceleration/deceleration)/11:FRS(free run stop)/12:EXT(external trip)/13:USP(USP function)/15:SFT(soft lock)/16:AT(analog input switch)/18:RS(reset)/19:PTC(thermistor input)/ 20:STA(3-wire start)/21:STP(3-wire stop)/22:F/R(3-wire forward/reverse)/23:PID(PID enable/disable)/24:PIDC(PID integral/reset)/ 27:UP(UP/DWN function accelerated)/ 28:DWN(UP/DWN function decelerated)/ 29:UDC(UP/DWN function data clear)/ 31:OPE(forward operator)/50:ADD(frequency addition)/51:F-TM(forced terminal block)/ 52:RDY(ready function)/53:SP-SET(special 2nd function)/64:EMR(emergency shut off)/ 255:No function
C002/C202	Multi-function input2 selection/2nd multi-function input2 selection	
C003/C203	Multi-function input3 selection/2nd multi-function input3 selection	
C004/C204	Multi-function input4 selection/2nd multi-function input4 selection	
C005/C205	Multi-function input5 selection/2nd multi-function input5 selection	
C011 to C015	Multi-function input 1-5 operation selection	00:NO 01:NC
C021	Multi-function output terminal 11 selection	00:RUN(during RUN)/01:FA1(constant speed reached)/02:FA2(set frequency min. reached)/ 03:OL(overload warning)/04:OD(PID excessive deviation)/05:AL(alarm output)/06:Dc(disconnection detected)/07:FBV(PID FB value output)/08:NDc(Network error)/09:LOG(logic operation output)/10:ODc(communication option, disconnected)/43:LOC(light load deflection)
C026	Relay output (AL1,AL2) function selection	
C028	AM selection	00:Output frequency/01:Output current
C031	Multi-function output Terminal 11 contact selection	00:NO contact at AL1, NC contact at AL2 01:NC contact at AL1, NO contact at AL2
C036	Relay output (AL1,AL2) contact selection	
H003/H203	Motor capacity selection/2nd motor capacity selection	200V class: 0.2 to 7.5 400V class: 0.4 to 7.5
H004/H204	Motor pole number selection/2nd motor pole number selection	2/4/6/8

### SUITABILITY FOR USE

OMRON shall not be responsible for conformity with any standards, code, or regulations that apply to the combination of products in the customer's application or use of the products.

Take all necessary steps to determine the suitability of the product for the systems, machines, and equipment with which it will be used. Please know and observe all prohibitions of use applicable to the products.

NEVER USE THE PRODUCTS FOR AN APPLICATION INVOLVING SERIOUS RISK TO LIFE OR PROPERTY WITHOUT ENSURING THAT THE SYSTEM AS A WHOLE HAS BEEN DESIGNED TO ADDRESS THE RISKS, AND THAT THE OMRON PRODUCTS ARE PROPERLY RATED AND INSTALLED FOR THE INTENDED USE WITHIN THE OVERALL EQUIPMENT OR SYSTEM.

See also product catalogs for Warranty and Limitations of Liability.

Local support office:



OMRON Corporation  
Industrial Automation Company

Control Devices Division H.Q.  
Motion Control Division  
Shiokoji Horikawa, Shimogyo-ku,  
Kyoto, 600-8530 Japan  
Tel: (81) 75-344-7173  
Fax: (81) 75-344-7149

Regional Headquarters  
OMRON EUROPE B.V.  
Wegalaan 67-69-2132 JD Hoofddorp  
The Netherlands  
Tel. (31)2356-81-300  
Fax: (31)2356-81-388

2-2-1 Nishikusatsu, Kusatsu-shi,  
Shiga, 525-0035 Japan  
Tel: (81) 77-565-5223  
Fax: (81) 77-565-5568

**Note:** In the interest of product improvement, specifications are subject to change without notice.

Printed in Japan

## Safety Precautions

### ■ Indications and Meanings of Safety Information

In this user's manual, the following precautions and signal words are used to provide information to ensure the safe use of the JX Inverter. The information provided here is vital to safety. Strictly observe the precautions provided.

### ■ Meanings of Signal Words

<b>DANGER</b>	Indicates an imminently hazardous situation which, if not avoided, is likely to result in serious injury or may result in death. Additionally there may be severe property damage.
---------------	--

<b>CAUTION</b>	Indicates a potentially hazardous situation which, if not avoided, may result in minor or moderate injury or in property damage.
----------------	--

### ■ Alert Symbols in this Document

<b>DANGER</b>	
	Turn off the power supply and implement wiring correctly. Not doing so may result in a serious injury due to an electric shock.
	Wiring work must be carried out only by qualified personnel. Not doing so may result in a serious injury due to an electric shock.
	Be sure to ground the unit. Not doing so may result in a serious injury due to an electric shock or fire. (200 V class: type-D grounding, 400 V class: type-C grounding)
	Do not remove the front cover during the power supply and 5 minutes after the power shut off. Doing so may result in a serious injury due to an electric shock.
	Do not operate the Operator or switches with wet hands. Doing so may result in a serious injury due to an electric shock.
	Inspection of the Inverter must be conducted after the power supply has been turned off. Not doing so may result in a serious injury due to an electric shock. The main power supply is not necessarily shut off even if the emergency shut off function is activated.
	Do not change wiring, mode change switches (S7, S8), optional devices or replace cooling fans while power is being supplied. Doing so may result in a serious injury due to an electric shock.

<b>CAUTION</b>	
	Do not connect resistors to the terminals (+1, +, -) directly. Doing so might result in a small-scale fire, heat generation or damage to the unit.
	Install a stop motion device to ensure safety. Not doing so might result in a minor injury. (A holding brake is not a stop motion device designed to ensure safety.)
	Be sure to use a specified type of braking resistor/regenerative braking unit. In case of a braking resistor, install a thermal relay that monitors the temperature of the resistor. Not doing so might result in a moderate burn due to the heat generated in the braking resistor/regenerative braking unit. Configure a sequence that enables the Inverter power to turn off when unusual overheating is detected in the braking resistor/regenerative braking unit.
	The Inverter has high voltage parts inside which, if short-circuited, might cause damage to itself or other property. Place covers on the openings or take other precautions to make sure that no metal objects such as cutting bits or lead wire scraps go inside when installing and wiring.
	Do not touch the Inverter fins, braking resistors and the motor, which become too hot during the power supply and for some time after the power shut off. Doing so may result in a burn.
	Take safety precautions such as setting up a molded-case circuit breaker(MCCB) that matches the Inverter capacity on the power supply side. Not doing so might result in damage to property due to the short circuit of the load.
	Do not dismantle, repair or modify this product. Doing so may result in an injury.

## Precautions for Safe Use

### ■ Installation and Storage

Do not store or use the product in the following places.

- Locations subject to direct sunlight.
- Locations subject to ambient temperature exceeding the specifications.
- Locations subject to relative humidity exceeding the specifications.
- Locations subject to condensation due to severe temperature fluctuations.
- Locations subject to corrosive or flammable gases.
- Locations subject to exposure to combustibles.
- Locations subject to dust (especially iron dust) or salts.
- Locations subject to exposure to water, oil, or chemicals.
- Locations subject to shock or vibration.

### ■ Transporting, Installation, and Wiring

- Do not drop or apply strong impact on the product. Doing so may result in damaged parts or malfunction.
- Do not hold by the front cover, but hold by the fins during transportation.
- Do not connect an AC power supply voltage to the control input/output terminals. Doing so may result in damage to the product.
- Be sure to tighten the screws on the terminal block securely. Wiring work must be done after installing the unit body.
- Do not connect any load other than a three-phase inductive motor to the U, V, and W output terminals.
- Take sufficient shielding measures when using the product in the following locations. Not doing so may result in damage to the product.
  - Locations subject to static electricity or other forms of noise.
  - Locations subject to strong magnetic fields.
  - Locations close to power lines.

### ■ Operation and Adjustment

- Be sure to confirm the permissible range of motors and machines before operation because the inverter speed can be changed easily from low to high.
- Provide a separate holding brake if necessary.

### ■ Maintenance and Inspection

- Be sure to confirm safety before conducting maintenance, inspection or parts replacement.

## Precautions for Correct Use

### ■ Installation

- Mount the product vertically on a wall or on a DIN Rail (optional) with the product's lower sides upright.  
The material of the wall has to be nonflammable such as a metal plate.

### ■ Main Circuit Power Supply

- Confirm that the rated input voltage of the Inverter is the same as AC power supply voltage.

### ■ Error Retry Function

- Do not come close to the machine when using the error retry function because the machine may abruptly start when stopped by an alarm.
- Be sure to confirm the RUN signal is turned off before resetting the alarm because the machine may abruptly start.

### ■ Non-Stop Function at Momentary Power Interruption

- Do not come close to the machine when selecting reset in the non-stop function at momentary power interruption selection (b050) because the machine may abruptly start after the power is turned on.

### ■ Operation Stop Command

- Provide a separate emergency stop switch because the STOP Key on the Operator is valid only when function settings are performed.
- When checking a signal during the power supply and the voltage is erroneously applied to the control input terminals, the motor may start abruptly. Be sure to confirm safety before checking a signal.

### ■ Product Disposal

- Comply with the local ordinance and regulations when disposing of the product.

## UL Cautions

The warnings and instructions in this section summarizes the procedures necessary to ensure an inverter installation complies with Underwriters Laboratories guidelines.

- Use 60/75°C Cu wire only or equivalent.  
(For models: X200-015L(A2015), -022L(A2022), -037L(A2037), -055L(A2055), -075L(A2075), -007S(AB007), -015S(AB015), -022S(AB022))
- Use 75°C Cu wire only or equivalent.  
(For models: X200-002L(A2002), -004L(A2004), -007L(A2007), -022H(A4022), -040H(A4040), -055H(A4055), -075H(A4075), -002S(AB002), -004S(AB004))
- Use 60°C Cu wire only or equivalent.  
(For models: X200-004H(A4004), -007H(A4007), -015H(A4015))
- Open Type Equipment.
- Suitable for use on a circuit capable of delivering not more than 100k rms symmetrical amperes, 240 V maximum when protected by Class CC, G, J or R fuses or circuit breaker having an interrupting rating not less than 100,000 rms symmetrical amperes, 240 volts maximum.  
(For models: 200 V class)
- Suitable for use on a circuit capable of delivering not more than 100k rms symmetrical amperes, 480 V maximum when protected by Class CC, G, J or R fuses or circuit breaker having an interrupting rating not less than 100,000 rms symmetrical amperes, 480 volts maximum.  
(For models: 400 V class)
- Install device in non-pollution degree 2 environment.
- Maximum Surrounding Air Temperature 50°C or equivalent.
- Caution-Risk of electric shock, -capacitor discharge time is at least 5 minutes.
- Solid state motor overload protection is provided in each model.
- Integral solid state short circuit protection does not provide branch circuit protection. Branch circuit protection must be provided in accordance with the National Electric Code and any additional local codes or equivalent.

### ■ Terminal Tightening Torque and Wire Size

The wire size range and tightening torque for field wiring terminals are presented in the tables below.

Input Voltage	Motor Output		Inverter Model X200- (JX-)	Power Terminal Wiring Size Range (AWG)	Torque	
	kW	HP			Ft-lbs	(N-m)
200 V class	0.2	1/4	002LFRF/SFEF (A2002/AB002)	14 (75°C only)	0.6	0.8
	0.4	1/2	004LFRF/SFEF (A2004/AB004)			
	0.75	1	007LFRF/SFEF (A2007/AB007)			
	1.5	2	015LFRF/SFEF (A2015/AB015)	12	0.9	1.2
	2.2	3	022LFRF/SFEF (A2022/AB022)	10		
	3.7	5	037LFRF (A2037)			
	5.5	7 1/2	055LFRF (A2055)	8		
7.5	10	075LFRF (A2075)				
400 V class	0.4	1/2	004HFEF (A4004)	16 (60°C only)	0.9	1.2
	0.75	1	007HFEF (A4007)			
	1.5	2	015HFEF (A4015)			
	2.2	3	022HFEF (A4022)	14 (75°C only)	2.3	3.0
	4	5	040HFEF (A4040)			
	5.5	7 1/2	055HFEF (A4055)	10		
	7.5	10	075HFEF (A4075)			

Terminal Connector	Wiring Size Range (AWG)	Torque	
		Ft-lbs	(N-m)
Logic and Analog connectors	30-16	0.16-0.19	0.22-0.25
Relay connector	30-14	0.37-0.44	0.5-0.6

### ■ Wire Connectors

Field wiring connections must be made by a UL Listed and CSA certified ring lug terminal connector sized for the wire gauge being used. The connector must be fixed using the crimping tool specified by the connector manufacturer.

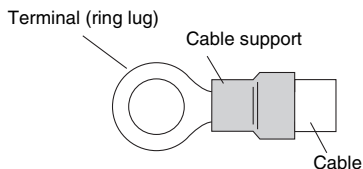

### ■ Circuit breaker and Fuse Size

The Inverter's connections to input power must include UL Listed inverse time circuit breakers with 600 V rating, or UL Listed fuses as shown in the table below.

Input Voltage	Inverter Model X200- (JX-)	Circuit Breaker/Fuse	Rated Current (A)
200V class	002LFRF/SFEF (A2002/AB002)	Inverse time circuit Breaker	10
	004LFRF/SFEF (A2004/AB004)		
	007LFRF/SFEF (A2007/AB007)		
	015LFRF/SFEF (A2015/AB015)		15
	022LFRF/SFEF (A2022/AB022)		20
	037LFRF (A2037)		30
	055LFRF (A2055)		40
400V class	075LFRF (A2075)	Distribution Fuse (Class J)	50
	004HFEF (A4004)		3
	007HFEF (A4007)		6
	015HFEF (A4015)		10
	022HFEF (A4022)		15
	040HFEF (A4040)		
055HFEF (A4055)			
075HFEF (A4075)	20		
		25	

### ■ Motor Overload Protection

JX Inverters provide solid state motor overload protection, which depends on the proper setting of the following parameters:

- b012: electronic overload protection
- b212: electronic overload protection, 2nd motor

Set the rated current [Amperes] of the motor(s) with the above parameters. The setting range is 0.2 rated current to 1.0 rated current.

When two or more motors are connected to the Inverter, they cannot be protected by the electronic overload protection. Install an external thermal relay on each motor.

## Conformance to EC Directives

- For earthing, selection of cable, and any other conditions for EMC-compliance, please refer to the manual for installation.
- This is a class A product in residential areas it may cause radio interference, in which case the user may be required to take adequate measures to reduce interference.

### ■ JX series Inverter has integrated EMC filter as shown below

- 200 V class: EN61800-3 category C1
- 400 V class: EN61800-3 category C2

### ■ OMRON Corporation

Shiokoji Horikawa, Shimogyo-ku, Kyoto, 600-8530, Japan

### ■ Omron Europe B.V.

Wegalaan 67-69, NL-2132 JD Hoofddorp, The Netherlands