

VARISPEED G7

General purpose inverter (Advanced Vector Control)

INSTRUCTION MANUAL



Varispeed G7

INSTRUCTION MANUAL

GENERAL PURPOSE INVERTER (ADVANCED VECTOR CONTROL)

MODEL: CIMR-G7C [] [] [] []

200V CLASS 0.4 to 110kW (1.2 to 160kVA)

400V CLASS 0.4 to 300kW (1.2 to 460kVA)

Upon receipt of the product and prior to initial operation, read these instructions thoroughly, and retain for future reference.



Preface

This manual is designed to ensure correct and suitable application of Varispeed G7-Series Inverters. Read this manual before attempting to install, operate, maintain, or inspect an Inverter and keep it in a safe, convenient location for future reference. Before you understand all precautions and safety information before attempting application.

General Precautions

- The diagrams in this manual may be indicated without covers or safety shields to show details. Be sure to restore covers or shields before operating the Units and run the Units according to the instructions described in this manual.
- Any illustrations, photographs, or examples used in this manual are provided as examples only and may not apply to all products to which this manual is applicable.
- The products and specifications described in this manual or the content and presentation of the manual may be changed without notice to improve the product and/or the manual.
- When ordering a new copy of the manual due to damage or loss, contact your Yaskawa representatives or the nearest Yaskawa sales office and provide the manual number shown on the front cover.
- If nameplates become worn or damaged, order new ones from your Yaskawa representatives or the nearest Yaskawa sales office.

Safety Information

The following conventions are used to indicate precautions in this manual. Failure to heed precautions provided in this manual can result in serious or possibly even fatal injury or damage to the products or to related equipment and systems.



Indicates precautions that, if not heeded, could possibly result in loss of life or serious injury.



Indicates precautions that, if not heeded, could result in relatively serious or minor injury, damage to the product, or faulty operation.

Failure to heed a precaution classified as a caution can result in serious consequences depending on the situation.



Indicates important information that should be memorized.

Safety Precautions

■ Confirmations upon Delivery



CAUTION

- Never install an Inverter that is damaged or missing components.
Doing so can result in injury.

■ Installation



CAUTION

- Always hold the case when carrying the Inverter.
If the Inverter is held by the front cover, the main body of the Inverter may fall, possibly resulting in injury.
- Attach the Inverter to a metal or other noncombustible material.
Fire can result if the Inverter is attached to a combustible material.
- Install a cooling fan or other cooling device when installing more than one Inverter in the same enclosure so that the temperature of the air entering the Inverters is below 45°C.
Overheating can result in fires or other accidents.

■ Wiring



WARNING

- Always turn OFF the input power supply before wiring terminals.
Otherwise, an electric shock or fire can occur.
- Wiring must be performed by an authorized person qualified in electrical work.
Otherwise, an electric shock or fire can occur.
- Be sure to ground the ground terminal. (200 V class: Ground to 100 Ω or less, 400 V class: Ground to 10 Ω or less)
Otherwise, an electric shock or fire can occur.
- Always check the operation of any emergency stop circuits after they are wired.
Otherwise, there is the possibility of injury. (Wiring is the responsibility of the user.)
- Never touch the output terminals directly with your hands or allow the output lines to come into contact with the Inverter case. Never short the output circuits.
Otherwise, an electric shock or ground short can occur.



CAUTION

- Check to be sure that the voltage of the main AC power supply satisfies the rated voltage of the Inverter.
Injury or fire can occur if the voltage is not correct.
- Do not perform voltage withstand tests on the Inverter.
Otherwise, semiconductor elements and other devices can be damaged.
- Connect braking resistors, Braking Resistor Units, and Braking Units as shown in the I/O wiring examples.
Otherwise, a fire can occur.
- Tighten all terminal screws to the specified tightening torque.
Otherwise, a fire may occur.
- Do not connect AC power to output terminals U, V, and W.
The interior parts of the Inverter will be damaged if voltage is applied to the output terminals.
- Do not connect phase-advancing capacitors or LC/RC noise filters to the output circuits.
The Inverter can be damaged or internal parts burnt if these devices are connected.

 **CAUTION**

- Do not connect electromagnetic switches or contactors to the output circuits.
If a load is connected while the Inverter is operating, surge current will cause the overcurrent protection circuit inside the Inverter to operate.

■ **Setting User Constants**

 **CAUTION**

- Disconnect the load (machine, device) from the motor before performing rotational autotuning.
The motor may turn, possibly resulting in injury or damage to equipment. Also, motor constants cannot be correctly set with the motor attached to a load.
- Stay clear of the motor during rotational autotuning.
The motor may start operating suddenly when stopped, possibly resulting in injury.

■ **Trial Operation**

 **WARNING**

- Check to be sure that the front cover is attached before turning ON the power supply.
An electric shock may occur.
- Do not come close to the machine when the fault reset function is used. If the alarmed is cleared, the machine may start moving suddenly.
Also, design the machine so that human safety is ensured even when it is restarted.
Injury may occur.
- Provide a separate emergency stop switch; the Digital Operator STOP Key is valid only when its function is set.
Injury may occur.
- Reset alarms only after confirming that the RUN signal is OFF.
Injury may occur.

 **CAUTION**

- Don't touch the radiation fins (heatsink), braking resistor, or Braking Resistor Unit. These can become very hot.
Otherwise, a burn injury may occur.
- Be sure that the motor and machine is within the applicable ranges before starting operation.
Otherwise, an injury may occur.
- Provide a separate holding brake if necessary.
Always construct the external sequence to confirm that the holding brake is activated in the event of an emergency, a power failure, or an abnormality in the Inverter.
Failure to observe this caution can result in injury.
- If using an Inverter with an elevator, take safety measures on the elevator to prevent the elevator from dropping.
Failure to observe this caution can result in injury.
- Don't check signals while the Inverter is running.
Otherwise, the equipment may be damaged.
- Be careful when changing Inverter settings. The Inverter is factory set to suitable settings.
Otherwise, the equipment may be damaged.

■ Maintenance and Inspection

 WARNING
<ul style="list-style-type: none">• Do not touch the Inverter terminals. Some of the terminals carry high voltages and are extremely dangerous. Doing so can result in electric shock.• Always have the protective cover in place when power is being supplied to the Inverter. When attaching the cover, always turn OFF power to the Inverter through the MCCB. Doing so can result in electric shock.• After turning OFF the main circuit power supply, wait until the CHARGE indicator light goes out before performance maintenance or inspections. The capacitor will remain charged and is dangerous.• Maintenance, inspection, and replacement of parts must be performed only by authorized personnel. Remove all metal objects, such as watches and rings, before starting work. Always use grounded tools. Failure to heed these warning can result in electric shock.

 CAUTION
<ul style="list-style-type: none">• A CMOS IC is used in the control board. Handle the control board and CMOS IC carefully. The CMOS IC can be destroyed by static electricity if touched directly. The CMOS IC can be destroyed by static electricity if touched directly.• Do not change the wiring, or remove connectors or the Digital Operator, during operation. Doing so can result in personal injury.

■ Other

 WARNING
<ul style="list-style-type: none">• Do not attempt to modify or alter the Inverter. Doing so can result in electrical shock or injury.

Warning Information and Position

There is warning information on the Inverter in the position shown in the following illustration. Always heed the warnings.

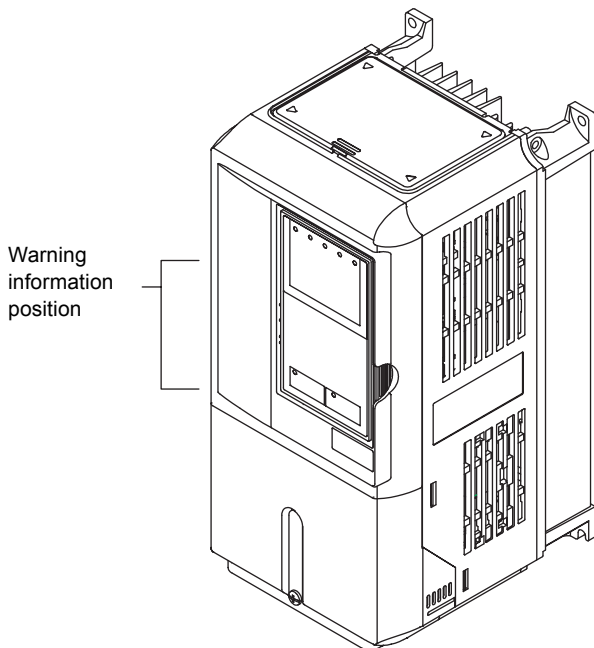

Illustration shows the CIMR-G7C20P4

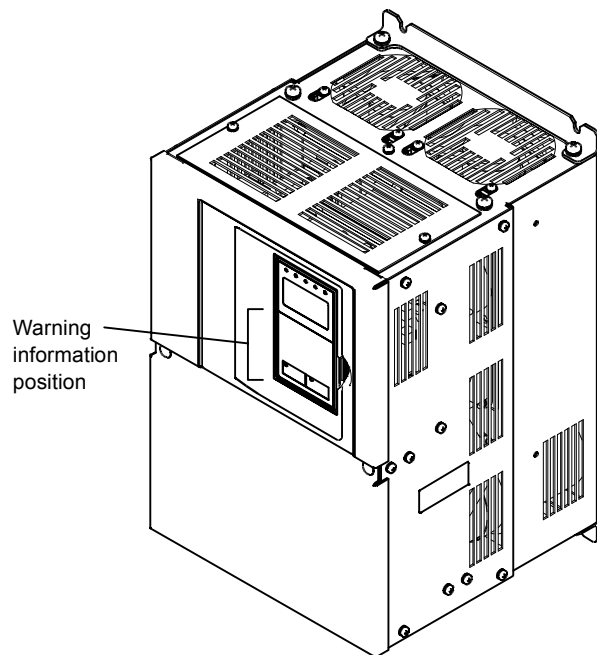

Illustration shows the CIMR-G7C2018

Warning Information

WARNING

 Risk of electric shock.

- Read manual before installing.
- Wait 5 minutes for capacitor discharge after disconnecting power supply.

AVERTISSEMENT

 Risque de décharge électrique.

- Lire le manuel avant l' installation.
- Attendre 5 minutes après la coupure de l' alimentation. Pour permettre la décharge des condensateurs.

危険

 けが・感電のおそれがあります。

- 据え付け・運転の前には必ず取扱説明書をお読み下さい。
- 通電中及び電源遮断後5分以内はフロントカバーを外さないで下さい。

Registered Trademarks

The following registered trademarks are used in this manual.

- DeviceNet is a registered trademark of the ODVA (Open DeviceNet Vendors Association, Inc.).
- InterBus is a registered trademark of Phoenix Contact Co.
- ControlNet is a registered trademark of ControlNet International, Ltd.
- LONworks is a registered trademark of the Echolon.



Contents

1	Handling Inverters	1-1
	Varispeed G7 Introduction	1-2
	◆ Varispeed G7 Models	1-2
	Confirmations upon Delivery	1-3
	◆ Checks	1-3
	◆ Nameplate Information	1-3
	◆ Component Names	1-5
	Exterior and Mounting Dimensions	1-7
	◆ Open Chassis Inverters (IP00)	1-7
	◆ Enclosed Wall-mounted Inverters (NEMA1 Type 1)	1-7
	Checking and Controlling the Installation Site	1-9
	◆ Installation Site	1-9
	◆ Controlling the Ambient Temperature	1-9
	◆ Protecting the Inverter from Foreign Matter	1-9
	Installation Orientation and Space	1-10
	Removing and Attaching the Terminal Cover	1-11
	◆ Removing the Terminal Cover	1-11
	◆ Attaching the Terminal Cover	1-11
	Removing/Attaching the Digital Operator and Front Cover	1-12
	◆ Inverters of 15 kW or Less	1-12
	◆ Inverters of 18.5 kW or More	1-15
2	Wiring	2-1
	Connections to Peripheral Devices	2-2
	Connection Diagram	2-3
	Terminal Block Configuration	2-5
	Wiring Main Circuit Terminals	2-6
	◆ Applicable Wire Sizes and Closed-loop Connectors	2-6
	◆ Main Circuit Terminal Functions	2-11
	◆ Main Circuit Configurations	2-12
	◆ Standard Connection Diagrams	2-13
	◆ Wiring the Main Circuits	2-14
	Wiring Control Circuit Terminals	2-20
	◆ Wire Sizes and Closed-loop Connectors	2-20
	◆ Control Circuit Terminal Functions	2-22
	◆ Control Circuit Terminal Connections	2-26
	◆ Control Circuit Wiring Precautions	2-27

Wiring Check	2-28
◆ Checks	2-28
Installing and Wiring Option Cards	2-29
◆ Option Card Models and Specifications	2-29
◆ Installation	2-29
◆ PG Speed Control Card Terminals and Specifications	2-30
◆ Wiring	2-32
◆ Wiring Terminal Blocks	2-36
◆ Selecting the Number of PG (Encoder) Pulses	2-37
3 Digital Operator and Modes	3-1
Digital Operator	3-2
◆ Digital Operator Display	3-2
◆ Digital Operator Keys	3-2
Modes	3-4
◆ Inverter Modes	3-4
◆ Switching Modes	3-5
◆ Drive Mode	3-6
◆ Quick Programming Mode	3-7
◆ Advanced Programming Mode	3-9
◆ Verify Mode	3-12
◆ Autotuning Mode	3-13
4 Trial Operation	4-1
Trial Operation Procedure	4-2
Trial Operation Procedures	4-3
◆ Setting the Power Supply Voltage Jumper (400 V Class Inverters of 55 kW or Higher)	4-3
◆ Power ON	4-3
◆ Checking the Display Status	4-4
◆ Basic Settings	4-5
◆ Settings for the Control Methods	4-7
◆ Autotuning	4-9
◆ Application Settings	4-14
◆ No-load Operation	4-14
◆ Loaded Operation	4-14
◆ Check and Recording User Constants	4-15
Adjustment Suggestions	4-16
5 User Constants	5-1
User Constant Descriptions	5-2
◆ Description of User Constant Tables	5-2
Digital Operation Display Functions and Levels	5-3
◆ User Constants Settable in Quick Programming Mode	5-4

User Constant Tables	5-8
◆ A: Setup Settings	5-8
◆ Application Constants: b	5-10
◆ Autotuning Constants: C	5-20
◆ Reference Constants: d	5-26
◆ Motor Constant Constants: E	5-32
◆ Option Constants: F	5-38
◆ Terminal Function Constants: H	5-45
◆ Protection Function Constants: L	5-57
◆ N: Special Adjustments	5-67
◆ Digital Operator Constants: o	5-70
◆ T: Motor Autotuning	5-74
◆ U: Monitor Constants	5-75
◆ Factory Settings that Change with the Control Method (A1-02)	5-83
◆ Factory Settings that Change with the Inverter Capacity (o2-04)	5-86

6 Constant Settings by Function..... 6-1

Frequency Reference	6-2
◆ Selecting the Frequency Reference Source	6-2
◆ Using Multi-Step Speed Operation	6-5
Run Command	6-7
◆ Selecting the Run Command Source	6-7
Stopping Methods	6-9
◆ Selecting the Stopping Method when a Stop Command is Sent	6-9
◆ Using the DC Injection Brake	6-13
◆ Using an Emergency Stop	6-14
Acceleration and Deceleration Characteristics	6-15
◆ Setting Acceleration and Deceleration Times	6-15
◆ Accelerating and Decelerating Heavy Loads (Dwell Function)	6-19
◆ Preventing the Motor from Stalling During Acceleration (Stall Prevention During Acceleration Function)	6-20
◆ Preventing Overvoltage During Deceleration (Stall Prevention During Deceleration Function)	6-22
Adjusting Frequency References	6-24
◆ Adjusting Analog Frequency References	6-24
◆ Operation Avoiding Resonance (Jump Frequency Function)	6-27
◆ Adjusting Frequency Reference Using Pulse Train Inputs	6-29
Speed Limit (Frequency Reference Limit Function)	6-30
◆ Limiting Maximum Output Frequency	6-30
◆ Limiting Minimum Frequency	6-30
Improved Operating Efficiency	6-32
◆ Reducing Motor Speed Fluctuation (Slip Compensation Function)	6-32
◆ Compensating for Insufficient Torque at Startup and Low-speed Operation (Torque Compensation)	6-34
◆ Hunting-prevention Function	6-36

◆ Stabilizing Speed (Speed Feedback Detection Function)	6-37
Machine Protection	6-38
◆ Reducing Noise and Leakage Current	6-38
◆ Limiting Motor Torque (Torque Limit Function)	6-41
◆ Preventing Motor Stalling During Operation	6-43
◆ Changing Stall Prevention Level during Operation Using an Analog Input	6-44
◆ Detecting Motor Torque	6-44
◆ Changing Overtorque and Undertorque Detection Levels Using an Analog Input	6-48
◆ Motor Overload Protection	6-49
◆ Setting Motor Protection Operation Time	6-51
◆ Motor Overheating Protection Using PTC Thermistor Inputs	6-52
◆ Limiting Motor Rotation Direction	6-54
Continuing Operation	6-55
◆ Restarting Automatically After Power Is Restored.....	6-55
◆ Speed Search.....	6-56
◆ Continuing Operation at Constant Speed When Frequency Reference Is Lost	6-62
◆ Restarting Operation After Transient Error (Auto Restart Function)	6-63
Inverter Protection	6-64
◆ Performing Overheating Protection on Mounted Braking Resistors	6-64
◆ Reducing Inverter Overheating Pre-Alarm Warning Levels	6-65
Input Terminal Functions	6-66
◆ Temporarily Switching Operation between Digital Operator and Control Circuit Terminals	6-66
◆ Blocking Inverter Outputs (Baseblock Commands).....	6-67
◆ Stopping Acceleration and Deceleration (Acceleration/Deceleration Ramp Hold).....	6-68
◆ Raising and Lowering Frequency References Using Contact Signals (UP/DOWN)	6-69
◆ Accelerating and Decelerating Constant Frequencies in the Analog References (+/- Speed)	6-72
◆ Hold Analog Frequency Using User-set Timing	6-73
◆ Switching Operations between a Communications Option Card and Control Circuit Terminals	6-73
◆ Jog Frequency Operation without Forward and Reverse Commands (FJOG/RJOG) .	6-74
◆ Stopping the Inverter by Notifying Programming Device Errors to the Inverter (External Fault Function)	6-75
Monitor Constants	6-76
◆ Using the Analog Monitor Constants	6-76
◆ Using Pulse Train Monitor Contents.....	6-79
Individual Functions	6-81
◆ Using MEMOBUS Communications	6-81
◆ Using the Timer Function	6-93
◆ Using PID Control.....	6-94
◆ Energy-saving	6-103
◆ Setting Motor Constants.....	6-105
◆ Setting the V/f Pattern	6-107
◆ Torque Control	6-114
◆ Speed Control (ASR) Structure	6-122

◆ Droop Control Function.....	6-127
◆ Zero-servo Function.....	6-128
Digital Operator Functions	6-132
◆ Setting Digital Operator Functions.....	6-132
◆ Copying Constants	6-135
◆ Prohibiting Writing Constants from the Digital Operator	6-139
◆ Setting a Password.....	6-140
◆ Displaying User-set Constants Only	6-141
Options	6-142
◆ Performing Speed Control with PG.....	6-142
◆ Using Digital Output Cards	6-146
◆ Using an Analog Reference Card	6-148
◆ Using a Digital Reference Card	6-149
7 Troubleshooting	7-1
Protective and Diagnostic Functions	7-2
◆ Fault Detection.....	7-2
◆ Alarm Detection	7-9
◆ Operation Errors	7-13
◆ Errors During Autotuning	7-15
◆ Errors when Using the Digital Operator Copy Function.....	7-16
Troubleshooting	7-17
◆ If Constant Constants Cannot Be Set.....	7-17
◆ If the Motor Does Not Operate.....	7-18
◆ If the Direction of the Motor Rotation is Reversed	7-19
◆ If the Motor Does Not Put Out Torque or If Acceleration is Slow	7-20
◆ If the Motor Operates Higher Than the Reference	7-20
◆ If the Slip Compensation Function Has Low Speed Precision.....	7-20
◆ If There is Low Speed Control Accuracy at High-speed Rotation in Open-loop Vector Control Mode	7-21
◆ If Motor Deceleration is Slow	7-21
◆ If the Motor Overheats	7-22
◆ If There is Noise When the Inverter is Started or From an AM Radio.....	7-22
◆ If the Ground Fault Interrupter Operates When the Inverter is Run.....	7-23
◆ If There is Mechanical Oscillation	7-23
◆ If the Motor Rotates Even When Inverter Output is Stopped.....	7-24
◆ If 0 V is Detected When the Fan is Started, or Fan Stalls.....	7-24
◆ If Output Frequency Does Not Rise to Frequency Reference	7-24
8 Maintenance and Inspection.....	8-1
Maintenance and Inspection.....	8-2
◆ Outline of Maintenance.....	8-2
◆ Daily Inspection	8-2
◆ Periodic Inspection	8-2

	◆ Periodic Maintenance of Parts	8-3
	◆ Cooling Fan Replacement Outline	8-4
	◆ Removing and Mounting the Control Circuit Terminal Card	8-6
9	Specifications	9-1
	Standard Inverter Specifications	9-2
	◆ Specifications by Model.....	9-2
	◆ Common Specifications.....	9-4
	Specifications of Options and Peripheral Devices	9-5
10	Appendix	10-1
	Varispeed G7 Control Modes	10-2
	◆ Control Modes and Features.....	10-2
	◆ Control Modes and Applications.....	10-5
	Inverter Application Precautions	10-7
	◆ Selection.....	10-7
	◆ Installation	10-8
	◆ Settings	10-8
	◆ Handling	10-9
	Motor Application Precautions	10-10
	◆ Using the Inverter for an Existing Standard Motor.....	10-10
	◆ Using the Inverter for Special Motors	10-11
	◆ Power Transmission Mechanism (Speed Reducers, Belts, and Chains)	10-11
	Conformance to CE Markings	10-12
	◆ CE Markings.....	10-12
	◆ Requirements for Conformance to CE Markings.....	10-12
	User Constants.....	10-19



1

Handling Inverters

This chapter describes the checks required upon receiving or installing an Inverter.

Varispeed G7 Introduction	1-2
Confirmations upon Delivery.....	1-3
Exterior and Mounting Dimensions.....	1-7
Checking and Controlling the Installation Site	1-9
Installation Orientation and Space.....	1-10
Removing and Attaching the Terminal Cover	1-11
Removing/Attaching the Digital Operator and Front Cover.....	1-12

Varispeed G7 Introduction

◆ Varispeed G7 Models

The Varispeed-G7 Series of Inverters included two Inverters in two voltage classes: 200 V and 400 V. Maximum motor capacities vary from 0.4 to 300 kW (41 models).

Table 1.1 Varispeed G7 Models

Voltage Class	Maximum Motor Capacity kW	Varispeed G7		Specifications (Always specify through the protective structure when ordering.)		
		Output Capacity kVA	Basic Model Number	Open Chassis (IEC IP00) CIMR-G7□□□□□□	Enclosed Wall-mounted (IEC IP20, NEMA 1) CIMR-G7C□□□□□□	
200 V class	0.4	1.2	CIMR-G7C20P4	Remove the top and bottom covers from the Enclosed Wall-mounted model.	20P41□	
	0.75	2.3	CIMR-G7C20P7		20P71□	
	1.5	3.0	CIMR-G7C21P5		21P51□	
	2.2	4.6	CIMR-G7C22P2		22P21□	
	3.7	6.9	CIMR-G7C23P7		23P71□	
	5.5	10	CIMR-G7C25P5		25P51□	
	7.5	13	CIMR-G7C27P5		27P51□	
	11	19	CIMR-G7C2011		2011□	
	15	25	CIMR-G7C2015		20151□	
	18.5	30	CIMR-G7C2018		20181□	
	22	37	CIMR-G7C2022		20220□	20221□
	30	50	CIMR-G7C2030		20300□	20301□
	37	61	CIMR-G7C2037		20370□	20371□
	45	70	CIMR-G7C2045		20450□	20451□
	55	85	CIMR-G7C2055	20550□	20551□	
	75	110	CIMR-G7C2075	20750□	20751□	
90	140	CIMR-G7C2090	20900□	-		
110	160	CIMR-G7C2110	21100□	-		
400 V class	0.4	1.4	CIMR-G7C40P4	Remove the top and bottom covers from the Enclosed Wall-mount model.	40P41□	
	0.75	2.6	CIMR-G7C40P7		40P71□	
	1.5	3.7	CIMR-G7C41P5		41P51□	
	2.2	4.7	CIMR-G7C42P2		42P21□	
	3.7	6.9	CIMR-G7C43P7		43P71□	
	5.5	11	CIMR-G7C45P5		45P51□	
	7.5	16	CIMR-G7C47P5		47P51□	
	11	21	CIMR-G7C4011		40111□	
	15	26	CIMR-G7C4015		40151□	
	18.5	32	CIMR-G7C4018		40181□	
	22	40	CIMR-G7C4022		40220□	40221□
	30	50	CIMR-G7C4030		40300□	40301□
	37	61	CIMR-G7C4037		40370□	40371□
	45	74	CIMR-G7C4045		40450□	40451□
	55	98	CIMR-G7C4055	40550□	40551□	
	75	130	CIMR-G7C4075	40750□	40751□	
	90	150	CIMR-G7C4090	40900□	40901□	
	110	180	CIMR-G7C4110	41100□	41101□	
132	210	CIMR-G7C4132	41320□	41321□		
160	230	CIMR-G7C4160	41600□	41601□		
185	280	CIMR-G7C4185	41850□	-		
220	340	CIMR-G7C4220	42200□	-		
300	460	CIMR-G7C4300	43000□	-		

Confirmations upon Delivery

◆ Checks

Check the following items as soon as the Inverter is delivered.

Table 1.2 Checks

Item	Method
Has the correct model of Inverter been delivered?	Check the model number on the nameplate on the side of the Inverter.
Is the Inverter damaged in any way?	Inspect the entire exterior of the Inverter to see if there are any scratches or other damage resulting from shipping.
Are any screws or other components loose?	Use a screwdriver or other tools to check for tightness.

If you find any irregularities in the above items, contact the agency from which you purchased the Inverter or your Yaskawa representative immediately.

1

◆ Nameplate Information

There is a nameplate attached to the side of each Inverter. The nameplate shows the model number, specifications, lot number, serial number, and other information on the Inverter.

■ Example Nameplate

The following nameplate is an example for a European standard Inverter: 3-phase, 200 VAC, 0.4 kW, IEC IP20 and NEMA 1 standards

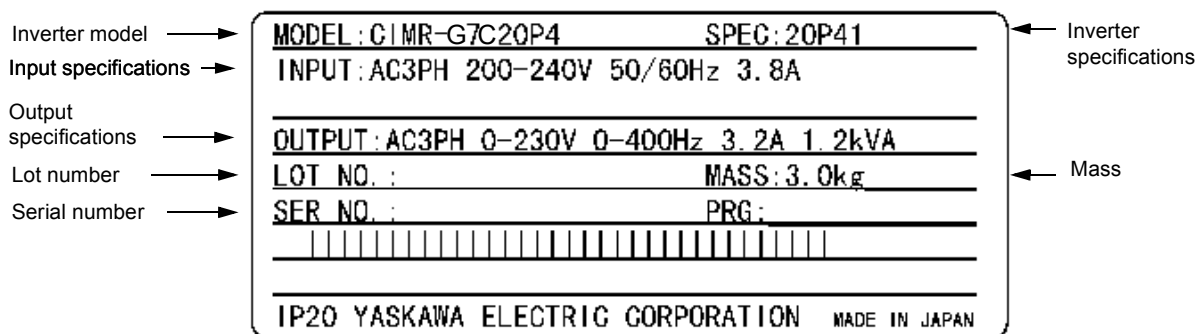

Fig 1.1 Nameplate

■ Inverter Model Numbers

The model number of the Inverter on the nameplate indicates the specification, voltage class, and maximum motor capacity of the Inverter in alphanumeric codes.

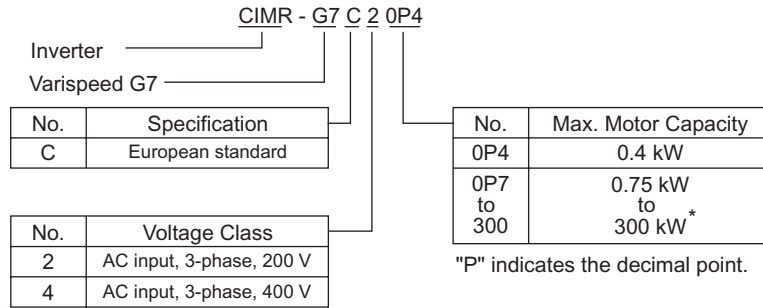

Fig 1.2 Inverter Model Numbers

■ Inverter Specifications

The Inverter specifications ("SPEC") on the nameplate indicate the voltage class, maximum motor capacity, the protective structure, and the revision of the Inverter in alphanumeric codes.

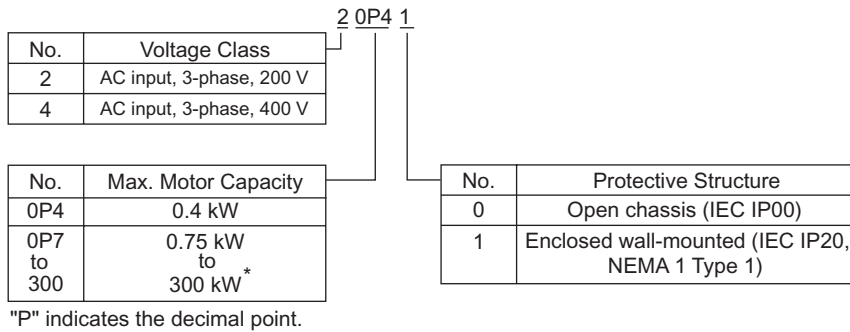

Fig 1.3 Inverter Specifications



TERMS

Open Chassis Type (IEC IP00)

Protected so that parts of the human body cannot reach electrically charged parts from the front when the Inverter is mounted in a control panel.

Enclosed Wall-mounted Type (IEC IP20, NEMA 1 Type 1)

The Inverter is structured so that the Inverter is shielded from the exterior, and can thus be mounted to the interior wall of a standard building (not necessarily enclosed in a control panel). The protective structure conforms to the standards of NEMA 1 in the USA.

Top protective cover must be installed to conform with IEC IP20 and NEMA 1 Type 1 requirements. Refer to Fig. 1.4 for details.

◆ Component Names

■ Inverters of 15 kW or Less

The external appearance and component names of the Inverter are shown in Fig 1.4. The Inverter with the terminal cover removed is shown in Fig 1.5.

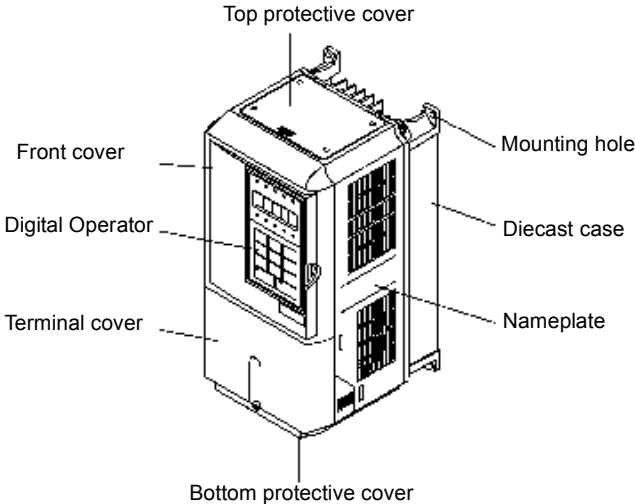

Fig 1.4 Inverter Appearance (15 kW or Less)

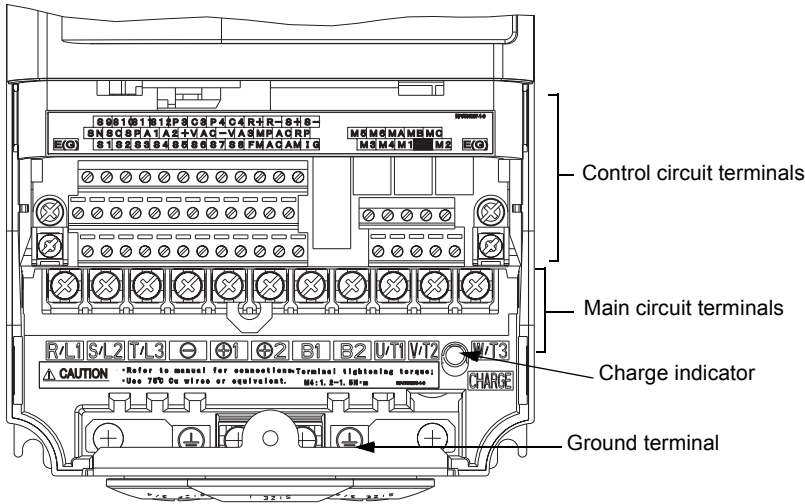

Fig 1.5 Terminal Arrangement (15 kW or Less)

■ Inverters of 18.5 kW or More

The external appearance and component names of the Inverter are shown in *Fig 1.6*. The Inverter with the terminal cover removed is shown in *Fig 1.7*.

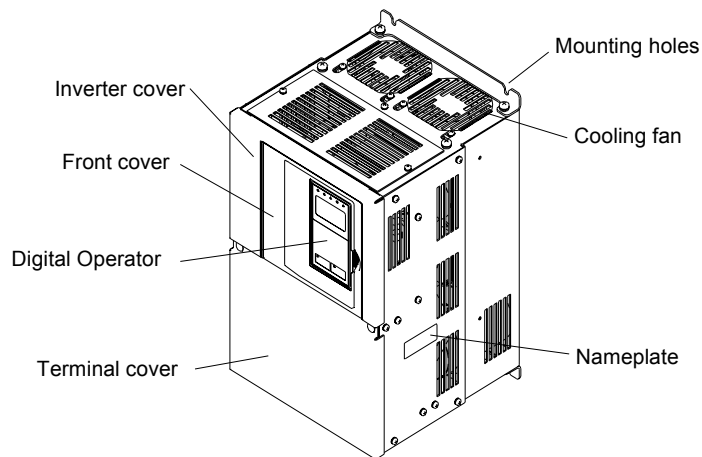

Fig 1.6 Inverter Appearance (18.5 kW or More)

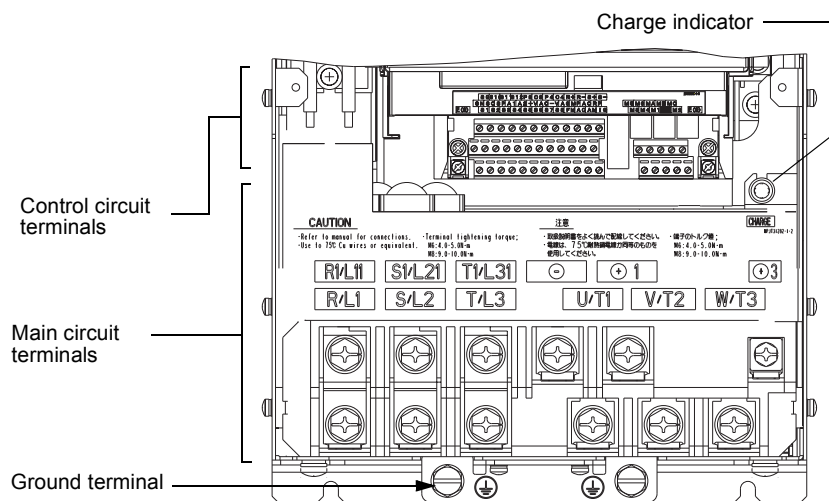
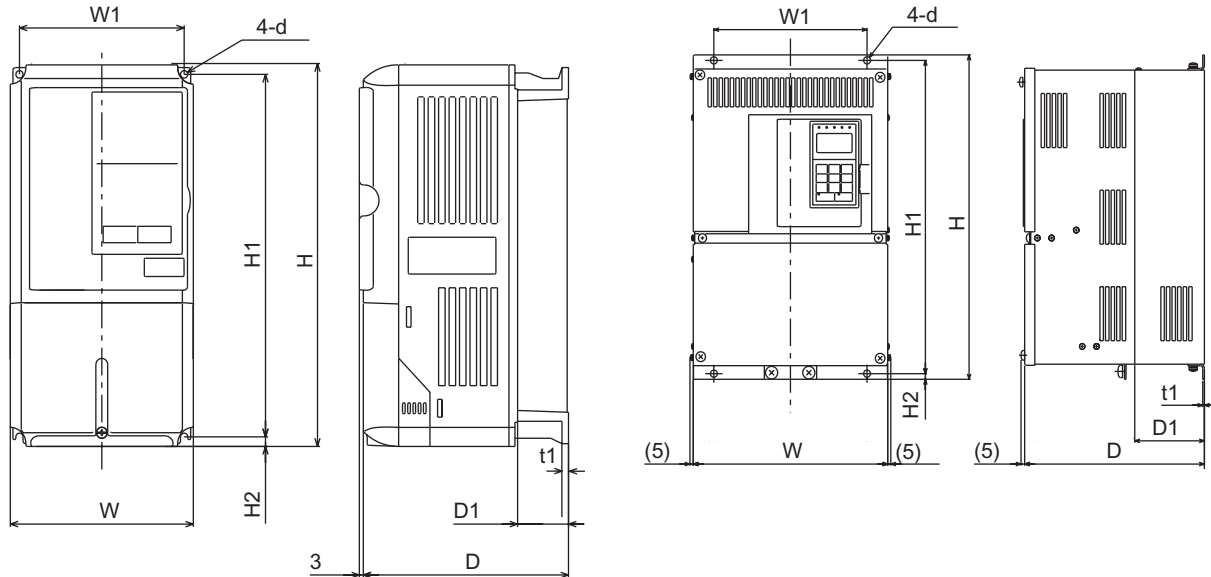

Fig 1.7 Terminal Arrangement (18.5 kW or More)

Exterior and Mounting Dimensions

◆ Open Chassis Inverters (IP00)

Exterior diagrams of the Open Chassis Inverters are shown below.



200 V/400 V Class Inverters of 0.4 to 15 kW

200 V Class Inverters of 18.5 or 22 kW
400 V Class Inverters of 30 to 45 kW

Fig 1.8 Exterior Diagrams of Open Chassis Inverters

◆ Enclosed Wall-mounted Inverters (NEMA1 Type 1)

Exterior diagrams of the Enclosed Wall-mounted Inverters (NEMA1 Type 1) are shown below.

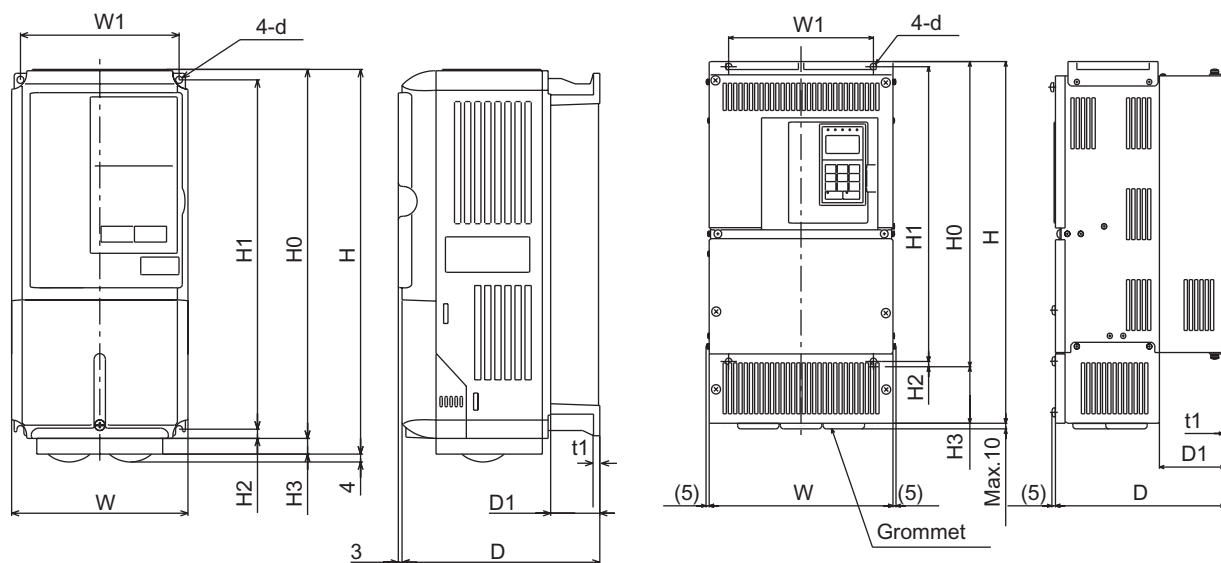

200 V/400 V Class Inverters of 0.4 to 15 kW

200 V Class Inverters of 18.5 or 22 kW
400 V Class Inverters of 30 to 45 kW

Fig 1.9 Exterior Diagrams of Enclosed Wall-mounted Inverters

Checking and Controlling the Installation Site

Install the Inverter in the installation site described below and maintain optimum conditions.

◆ Installation Site

Install the Inverter under the following conditions.

Table 1.4 Installation Site

Type	Ambient Operating Temperature	Humidity
Enclosed wall-mounted	-10 to + 40 °C	95% RH or less (no condensation)
Open chassis	-10 to + 45 °C	95% RH or less (no condensation)

Protection covers are attached to the top and bottom of the Inverter. Be sure to remove the protection covers before installing a 200 or 400 V Class Inverter with an output of 15 kW or less in a panel.

Observe the following precautions when mounting the Inverter.

- Install the Inverter in a clean location free from oil mist and dust. It can be installed in a totally enclosed panel that is completely shielded from floating dust.
- When installing or operating the Inverter, always take special care so that metal powder, oil, water, or other foreign matter does not get into the Inverter.
- Do not install the Inverter on combustible material, such as wood.
- Install the Inverter in a location free from radioactive materials and combustible materials.
- Install the Inverter in a location free from harmful gasses and liquids.
- Install the Inverter in a location without excessive oscillation.
- Install the Inverter in a location free from chlorides.
- Install the Inverter in a location not in direct sunlight.

◆ Controlling the Ambient Temperature

To enhance the reliability of operation, the Inverter should be installed in an environment free from extreme temperature increases. If the Inverter is installed in an enclosed environment, such as a box, use a cooling fan or air conditioner to maintain the internal air temperature below 45°C.

◆ Protecting the Inverter from Foreign Matter

Place a cover over the Inverter during installation to shield it from metal power produced by drilling.

Always remove the cover from the Inverter after completing installation. Otherwise, ventilation will be reduced, causing the Inverter to overheat.

Installation Orientation and Space

Install the Inverter vertically so as not to reduce the cooling effect. When installing the Inverter, always provide the following installation space to allow normal heat dissipation.

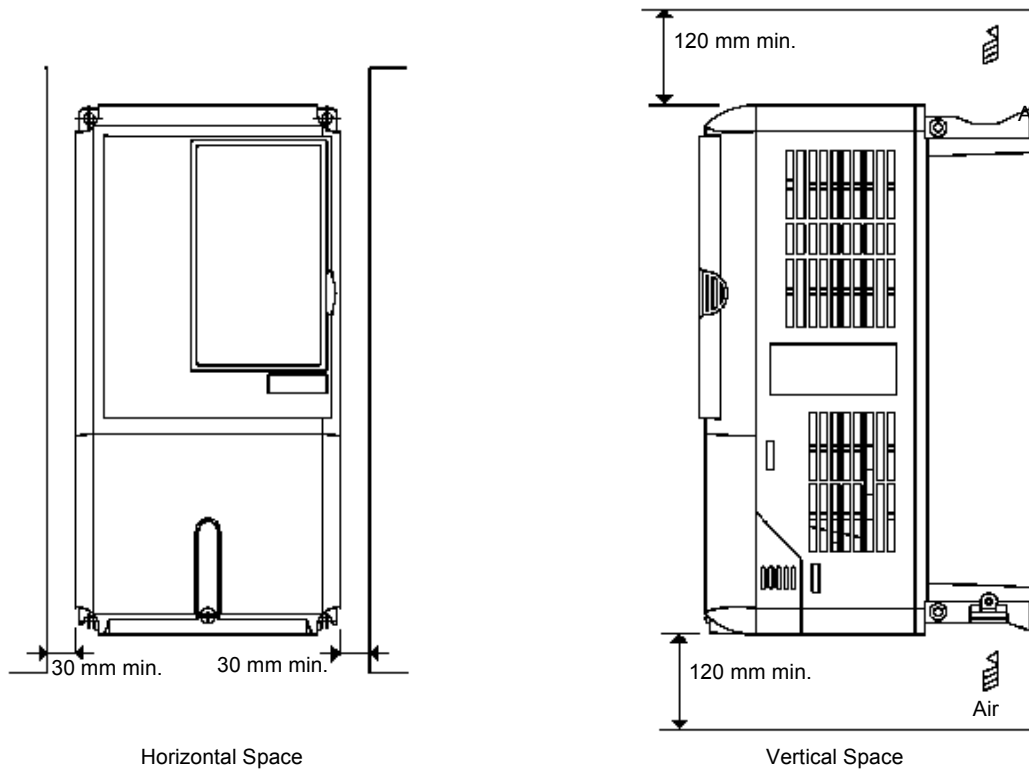

Fig 1.10 Inverter Installation Orientation and Space



IMPORTANT

1. The same space is required horizontally and vertically for both Open Chassis (IP00) and Enclosed Wall-mounted (IP20, NEMA 1 Type 1) Inverters.
2. Always remove the protection covers before installing a 200 or 400 V Class Inverter with an output of 15 kW or less in a panel.
Always provide enough space for suspension eye bolts and the main circuit lines when installing a 200 or 400 V Class Inverter with an output of 18.5 kW or more in a panel.

Removing and Attaching the Terminal Cover

Remove the terminal cover to wire cables to the control circuit and main circuit terminals.

◆ Removing the Terminal Cover

■ Inverters of 15 kW or Less

Loosen the screws at the bottom of the terminal cover, press in on the sides of the terminal cover in the directions of arrows 1, and then lift up on the terminal in the direction of arrow 2.

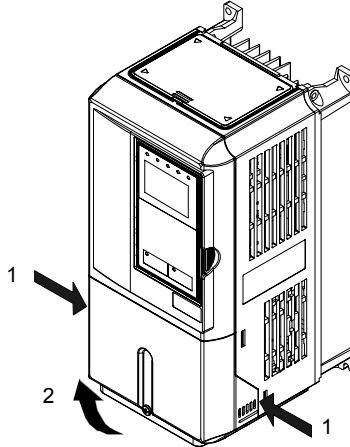

Fig 1.11 Removing the Terminal Cover (Model CIMR-G7C23P7 Shown Above)

■ Inverters of 18.5 kW or More

Loosen the screws on the left and right at the top of the terminal cover, pull out the terminal cover in the direction of arrow 1 and then lift up on the terminal in the direction of arrow 2.

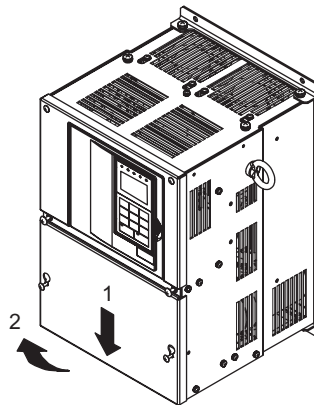

Fig 1.12 Removing the Terminal Cover (Model CIMR-G7C2018 Shown Above)

◆ Attaching the Terminal Cover

When wiring the terminal block has been completed, attach the terminal cover by reversing the removal procedure.

For Inverters with an output of 15 kW or less, insert the tab on the top of the terminal cover into the groove on the Inverter and press in on the bottom of the terminal cover until it clicks into place.

Removing/Attaching the Digital Operator and Front Cover

The methods of removing and attaching the Digital Operator and Front Cover are described in this section.

◆ Inverters of 15 kW or Less

To attach optional cards or change the terminal card connector, remove the Digital Operator and front cover in addition to the terminal cover. Always remove the Digital Operator from the front cover before removing the terminal cover.

The removal and attachment procedures are given below.

■ Removing the Digital Operator

Press the lever on the side of the Digital Operator in the direction of arrow 1 to unlock the Digital Operator and lift the Digital Operator in the direction of arrow 2 to remove the Digital Operator as shown in the following illustration.

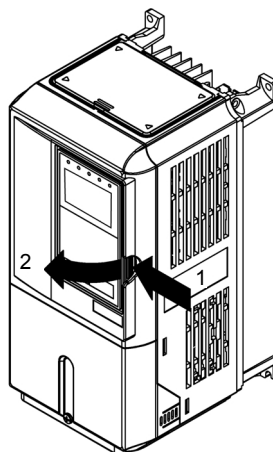

Fig 1.13 Removing the Digital Operator (Model CIMR-G7C43P7 Shown Above)

■ Removing the Front Cover

Press the left and right sides of the front cover in the directions of arrows 1 and lift the bottom of the cover in the direction of arrow 2 to remove the front cover as shown in the following illustration.

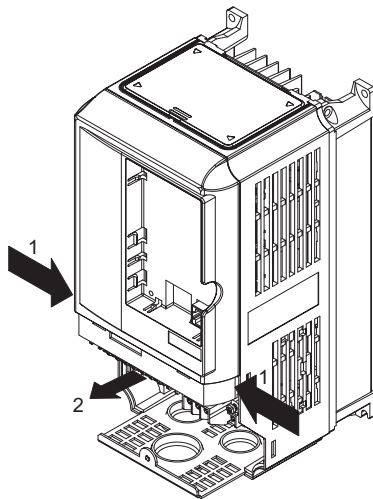

Fig 1.14 Removing the Front Cover (Model CIMR-G7C43P7 Shown Above)

■ Mounting the Front Cover

After wiring the terminals, mount the front cover to the Inverter by performing in reverse order to the steps to remove the front cover.

1. Do not mount the front cover with the Digital Operator attached to the front cover; otherwise, Digital Operator may malfunction due to imperfect contact.
2. Insert the tab of the upper part of the front cover into the groove of the Inverter and press the lower part of the front cover onto the Inverter until the front cover snaps shut.

■ Mounting the Digital Operator

After attaching the terminal cover, mount the Digital Operator onto the Inverting using the following procedure.

1. Hook the Digital Operator at A (two locations) on the front cover in the direction of arrow 1 as shown in the following illustration.
2. Press the Digital Operator in the direction of arrow 2 until it snaps in place at B (two locations).

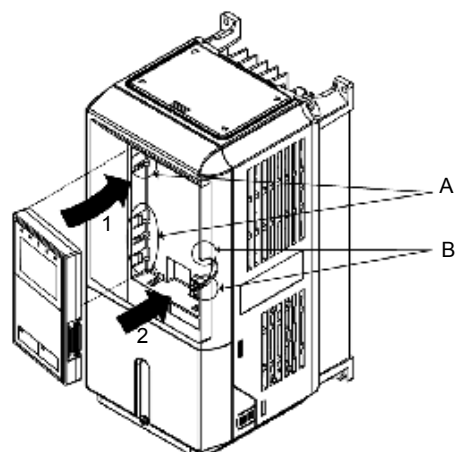

Fig 1.15 Mounting the Digital Operator



IMPORTANT

1. Do not remove or attach the Digital Operator or mount or remove the front cover using methods other than those described above, otherwise the Inverter may break or malfunction due to imperfect contact.
2. Never attach the front cover to the Inverter with the Digital Operator attached to the front cover. Imperfect contact can result.
Always attach the front cover to the Inverter by itself first, and then attach the Digital Operator to the front cover.

◆ Inverters of 18.5 kW or More

For Inverter with an output of 18.5 kW or more, remove the terminal cover and then use the following procedures to remove the Digital Operator and main cover.

■ Removing the Digital Operator

Use the same procedure as for Inverters with an output of 18.5 kW or less.

■ Removing the Front Cover

Lift up at the location label 1 at the top of the control circuit terminal card in the direction of arrow 2.

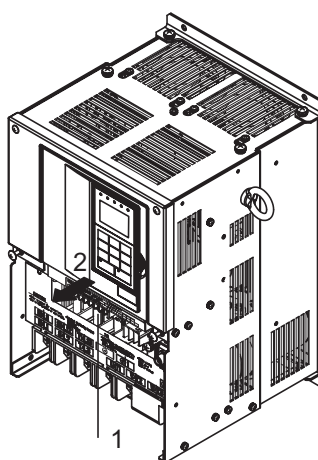

Fig 1.16 Removing the Front Cover (Model CIMR-G7C2018 Shown Above)

■ Attaching the Front Cover

After completing required work, such as mounting an optional card or setting the terminal card, attach the front cover by reversing the procedure to remove it.

1. Confirm that the Digital Operator is not mounted on the front cover. Contact faults can occur if the cover is attached while the Digital Operator is mounted to it.
2. Insert the tab on the top of the front cover into the slot on the Inverter and press in on the cover until it clicks into place on the Inverter.

■ Attaching the Digital Operator

Use the same procedure as for Inverters with an output of 15 kW or less.





2

Wiring

This chapter describes wiring terminals, main circuit terminal connections, main circuit terminal wiring specifications, control circuit terminals, and control circuit wiring specifications.

Connections to Peripheral Devices.....	2-2
Connection Diagram	2-3
Terminal Block Configuration	2-5
Wiring Main Circuit Terminals	2-6
Wiring Control Circuit Terminals	2-20
Wiring Check	2-28
Installing and Wiring Option Cards	2-29

Connections to Peripheral Devices

Examples of connections between the Inverter and typical peripheral devices are shown in *Fig 2.1*.

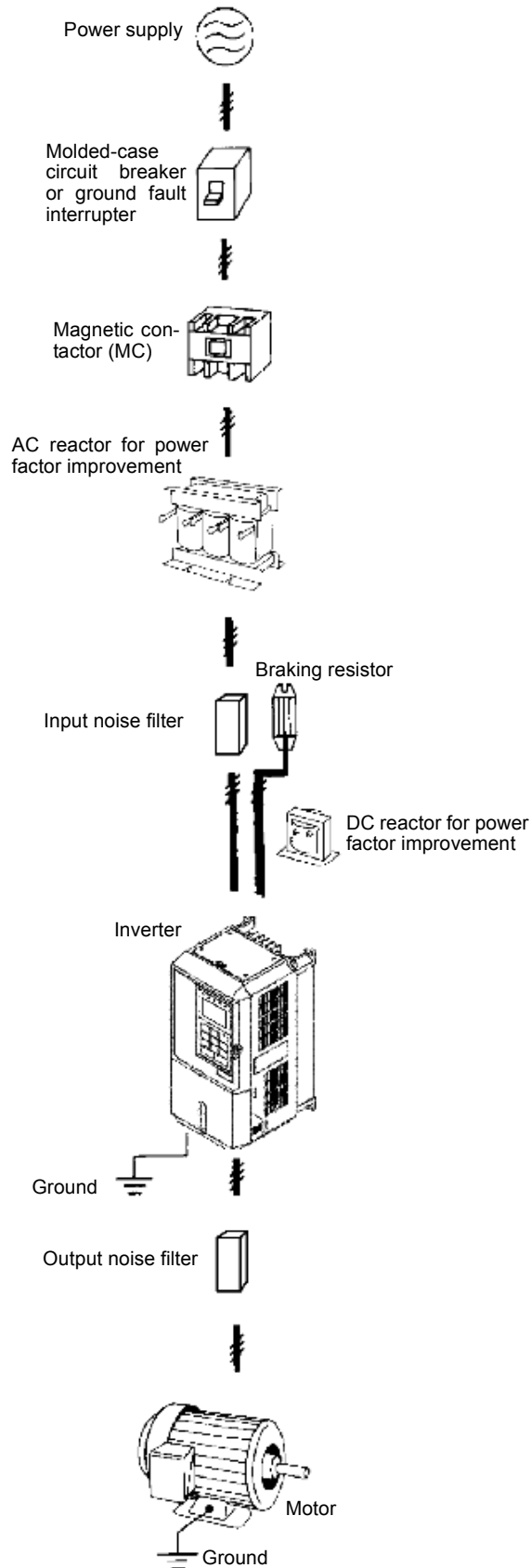

Fig 2.1 Example Connections to Peripheral Devices

Connection Diagram

The connection diagram of the Inverter is shown in Fig 2.2.

When using the Digital Operator, the motor can be operated by wiring only the main circuits.

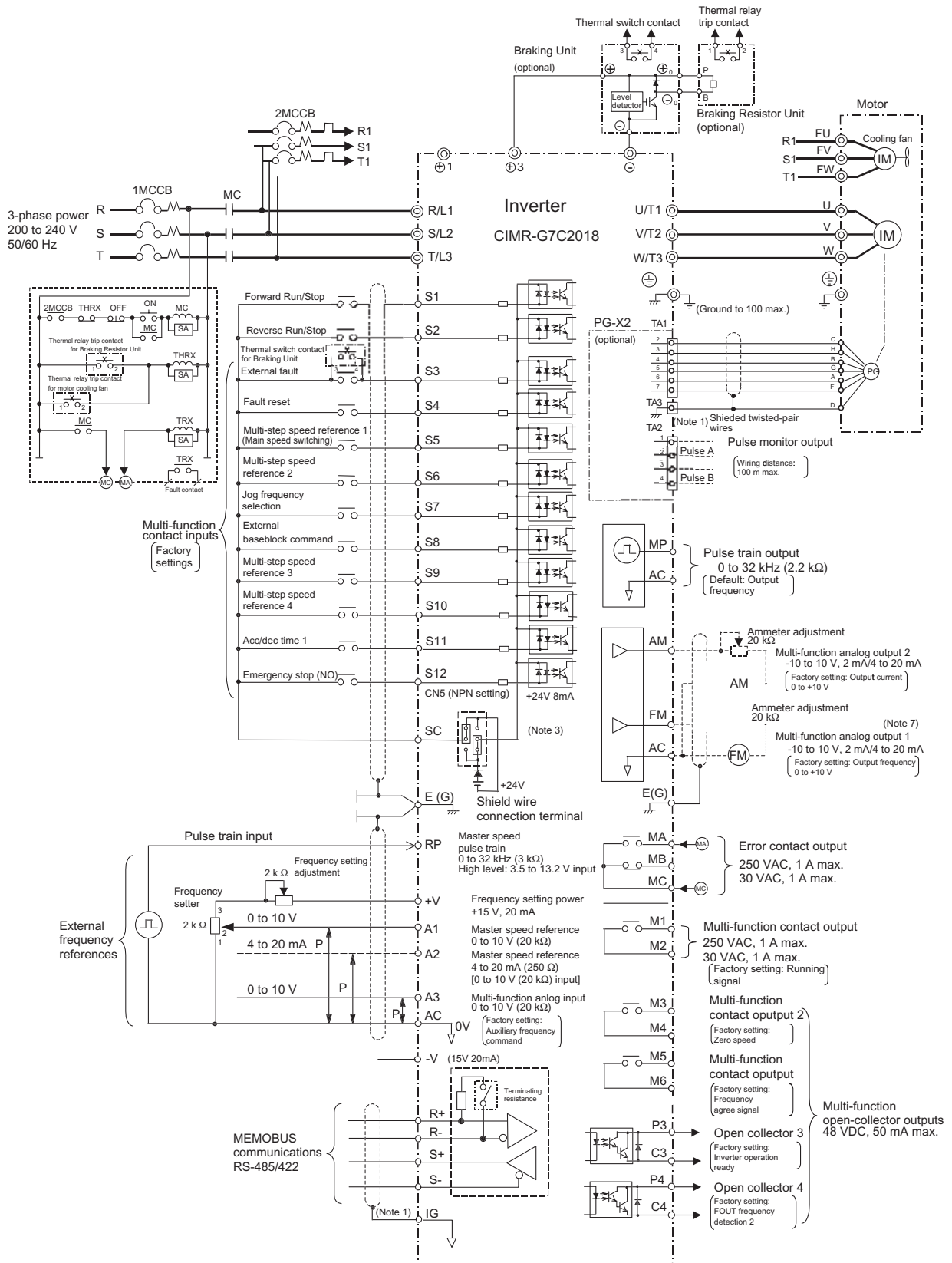

Fig 2.2 Connection Diagram (Model CIMR-G7C2018 Shown Above)



IMPORTANT

1. Control circuit terminals are arranged as shown below.



2. The output current capacity of the +V terminal is 20 mA.
3. Disable the stall prevention during deceleration (set constant L3-04 to 0) when using a Braking Resistor Unit. If this user constant is not changed to disable stall prevention, the system may not stop during deceleration.
4. Main circuit terminals are indicated with double circles and control circuit terminals are indicated with single circles.
5. The wiring for a motor with a cooling fan is not required for self-cooling motors.
6. PG circuit wiring (i.e., wiring to the PG-B2 Card) is not required for open-loop vector control.
7. Sequence input signals S1 to S12 are labeled for sequence connections (0 V common and sinking mode) for no-voltage contacts or NPN transistors. These are the default settings.
For PNP transistor sequence connections (+24V common and sourcing mode) or to provide a 24-V external power supply, refer to *Table 2.13*.
8. The master speed frequency reference can set to input either a voltage (terminal A1) or current (terminal A2) by changing the setting of parameter H3-13. The default setting is for a voltage reference input.
9. The multi-function analog output is a dedicated meter output for an analog frequency meter, ammeter, voltmeter, wattmeter, etc. Do not use this output for feedback control or for any other control purpose.
10. DC reactors to improve the input power factor built into 200 V Class Inverters for 18.5 to 110 kW and 400 V Class Inverters for 18.5 to 300 kW. A DC reactor is thus an option only for Inverters for 15 kW or less.
11. Set parameter L8-01 to 1 when using a braking resistor (ERF). When using a Braking Resistor Unit, a shutoff sequence for the power supply must be made using a thermal relay trip.

Terminal Block Configuration

The terminal arrangement for 200 V Class Inverters are shown in *Fig 2.3* and *Fig 2.4*.

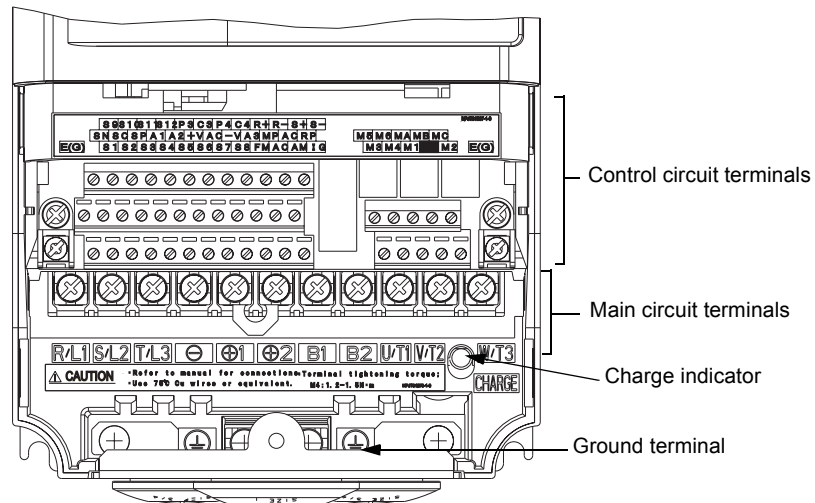

Fig 2.3 Terminal Arrangement (200 V Class Inverter for 0.4 kW Shown Above)

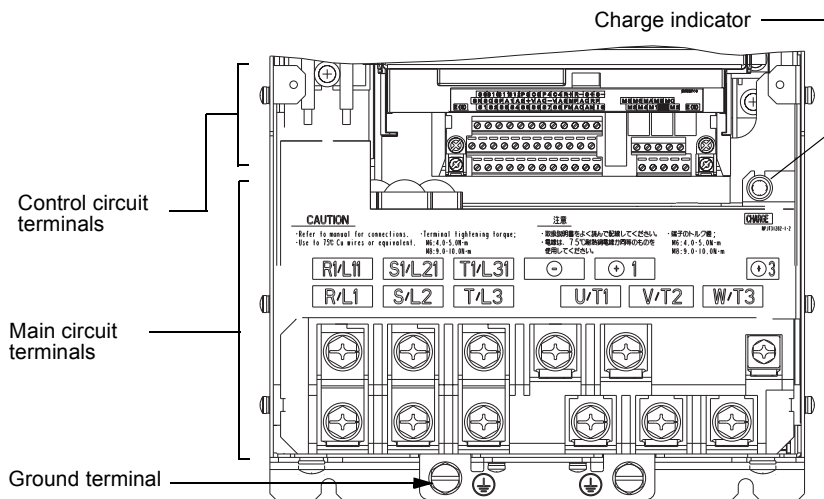

Fig 2.4 Terminal Arrangement (200 V Class Inverter for 18.5 kW Shown Above)

Wiring Main Circuit Terminals

◆ Applicable Wire Sizes and Closed-loop Connectors

Select the appropriate wires and crimp terminals from *Table 2.1* to *Table 2.3*. Refer to instruction manual TOE-C726-2 for wire sizes for Braking Resistor Units and Braking Units.

Table 2.1 200 V Class Wire Sizes

Inverter Model CIMR-□	Terminal Symbol	Terminal Screws	Tightening Torque (N•m)	Possible Wire Sizes mm ² (AWG)	Recommended Wire Size mm ² (AWG)	Wire Type
G7C20P4	R/L1, S/L2, T/L3, ⊖, ⊕1, ⊕2, B1, B2, U/T1, V/T2, W/T3	M4	1.2 to 1.5	2 to 5.5 (14 to 10)	2 (14)	Power cables, e.g., 600 V vinyl power cables
	⊕					
G7C20P7	R/L1, S/L2, T/L3, ⊖, ⊕1, ⊕2, B1, B2, U/T1, V/T2, W/T3	M4	1.2 to 1.5	2 to 5.5 (14 to 10)	2 (14)	
	⊕					
G7C21P5	R/L1, S/L2, T/L3, ⊖, ⊕1, ⊕2, B1, B2, U/T1, V/T2, W/T3	M4	1.2 to 1.5	2 to 5.5 (14 to 10)	2 (14)	
	⊕					
G7C22P2	R/L1, S/L2, T/L3, ⊖, ⊕1, ⊕2, B1, B2, U/T1, V/T2, W/T3	M4	1.2 to 1.5	2 to 5.5 (14 to 10)	3.5 (12)	
	⊕					
G7C23P7	R/L1, S/L2, T/L3, ⊖, ⊕1, ⊕2, B1, B2, U/T1, V/T2, W/T3	M4	1.2 to 1.5	2 to 5.5 (14 to 10)	5.5 (10)	
	⊕					
G7C25P5	R/L1, S/L2, T/L3, ⊖, ⊕1, ⊕2, B1, B2, U/T1, V/T2, W/T3	M5	2.5	8 to 14 (8 to 6)	8 (8)	
	⊕					
G7C27P5	R/L1, S/L2, T/L3, ⊖, ⊕1, ⊕2, B1, B2, U/T1, V/T2, W/T3	M5	2.5	14 (6)	14 (6)	
	⊕					
G7C2011	R/L1, S/L2, T/L3, ⊖, ⊕1, ⊕2, U/T1, V/T2, W/T3	M6	4.0 to 5.0	22 to 30 (4 to 3)	22 (4)	
	B1, B2	M5	2.5	8 to 14 (8 to 6)	-	
	⊕	M6	4.0 to 5.0	22 (4)	22 (4)	
G7C2015	R/L1, S/L2, T/L3, ⊖, ⊕1, ⊕2, U/T1, V/T2, W/T3	M8	9.0 to 10.0	22 to 38 (4 to 2)	30 (3)	
	B1, B2	M5	2.5	8 to 14 (8 to 6)	-	
	⊕	M6	4.0 to 5.0	22 (4)	22 (4)	
G7C2018	R/L1, S/L2, T/L3, ⊖, ⊕1, U/T1, V/T2, W/T3, R1/L11, S1/L21, T1/L31	M8	9.0 to 10.0	30 to 60 (3 to 1)	30 (3)	
	⊕3	M6	4.0 to 5.0	8 to 22 (8 to 4)	-	
	⊕	M8	9.0 to 10.0	22 to 38 (4 to 2)	22 (4)	
G7C2022	R/L1, S/L2, T/L3, ⊖, ⊕1 U/T1, V/T2, W/T3, R1/L11, S1/L21, T1/L31	M8	9.0 to 10.0	50 to 60 (1 to 1/0)	50 (1)	
	⊕3	M6	4.0 to 5.0	8 to 22 (8 to 4)	-	
	⊕	M8	9.0 to 10.0	22 to 38 (4 to 2)	22 (4)	
G7C2030	R/L1, S/L2, T/L3, ⊖, ⊕1 U/T1, V/T2, W/T3, R1/L11, S1/L21, T1/L31	M10	17.6 to 22.5	60 to 100 (2/0 to 4/0)	60 (2/0)	
	⊕3	M8	8.8 to 10.8	5.5 to 22 (10 to 4)	-	
	⊕	M10	17.6 to 22.5	30 to 60 (2 to 2/0)	30 (2)	
	t/ε1, /ε2	M4	1.3 to 1.4	0.5 to 5.5 (20 to 10)	1.25 (16)	

Inverter Model CIMR-□	Terminal Symbol	Terminal Screws	Tightening Torque (N•m)	Possible Wire Sizes mm ² (AWG)	Recommended Wire Size mm ² (AWG)	Wire Type
G7C2037	R/L1, S/L2, T/L3, ⊖, ⊕ 1 U/T1, V/T2, W/T3, R1/L11, S1/L21, T1/L31	M10	17.6 to 22.5	80 to 125 (3/0 to 250)	80 (3/0)	Power cables, e.g., 600 V vinyl power cables
	⊕ 3	M8	8.8 to 10.8	5.5 to 22 (10 to 4)	-	
	⊖	M10	17.6 to 22.5	38 to 60 (1 to 2/0)	38 (1)	
	r/ε 1, /ε 2	M4	1.3 to 1.4	0.5 to 5.5 (20 to 10)	1.25 (16)	
G7C2045	R/L1, S/L2, T/L3, ⊖, ⊕ 1, U/T1, V/T2, W/T3, R1/L11, S1/L21, T1/L31	M10	17.6 to 22.5	50 to 100 (1/0 to 4/0)	50 × 2P (1/0 × 2P)	
	⊕ 3	M8	8.8 to 10.8	5.5 to 60 (10 to 2/0)	-	
	⊖	M10	17.6 to 22.5	30 to 60 (3 to 4/0)	50 (1/0)	
	r/ε 1, /ε 2	M4	1.3 to 1.4	0.5 to 5.5 (20 to 10)	1.25 (16)	
G7C2055	⊖, ⊕ 1	M12	31.4 to 39.2	80 to 125 (3/0 to 250)	80 × 2P (3/0 × 2P)	
	R/L1, S/L2, T/L3, U/T1, V/T2, W/T3, R1/L11, S1/L21, T1/L31	M10	17.6 to 22.5	80 to 100 (3/0 to 4/0)	80 × 2P (3/0 × 2P)	
	⊕ 3	M8	8.8 to 10.8	5.5 to 60 (10 to 2/0)	-	
	⊖	M12	17.6 to 22.5	80 to 200 (2/0 to 400)	80 (2/0)	
	r/ε 1, /ε 2	M4	1.3 to 1.4	0.5 to 5.5 (20 to 10)	1.25 (16)	
G7C2075	R/L1, S/L2, T/L3, ⊖, ⊕ 1	M12	31.4 to 39.2	150 to 200 (250 to 350)	150 × 2P (250 × 2P)	
	U/T1, V/T2, W/T3, R1/L11, S1/L21, T1/L31	M12	31.4 to 39.2	100 to 150 (4/0 to 300)	100 × 2P (4/0 × 2P)	
	⊕ 3	M8	8.8 to 10.8	5.5 to 60 (10 to 2/0)	-	
	⊖	M12	31.4 to 39.2	60 to 150 (2/0 to 300)	60 × 2P (2/0 × 2P)	
	r/ε 1, /ε 2	M4	1.3 to 1.4	0.5 to 5.5 (20 to 10)	1.25 (16)	
G7C2090	R/L1, S/L2, T/L3, ⊖, ⊕ 1	M12	31.4 to 39.2	200 to 325 (350 to 600)	200 × 2P, or 50 × 4P (350 × 2P, or 1/0 × 4P)	
	U/T1, V/T2, W/T3, R1/L11, S1/L21, T1/L31	M12	31.4 to 39.2	150 to 325 (300 to 600)	150 × 2P, or 50 × 4P (300 × 2P, or 1/0 × 4P)	
	⊕ 3	M8	8.8 to 10.8	5.5 to 60 (10 to 2/0)	-	
	⊖	M12	31.4 to 39.2	150 (300)	150 × 2P (300 × 2P)	
	r/ε 1, /ε 2	M4	1.3 to 1.4	0.5 to 5.5 (20 to 10)	1.25 (16)	
G7C2110	R/L1, S/L2, T/L3, ⊖, ⊕ 1	M12	31.4 to 39.2	200 to 325 (350 to 600)	200 × 2P, or 50 × 4P (350 × 2P, or 1/0 × 4P)	
	U/T1, V/T2, W/T3, R1/L11, S1/L21, T1/L31	M12	31.4 to 39.2	150 to 325 (300 to 600)	150 × 2P, or 50 × 4P (300 × 2P, or 1/0 × 4P)	
	⊕ 3	M8	8.8 to 10.8	5.5 to 60 (10 to 2/0)	-	
	⊖	M12	31.4 to 39.2	150 (300)	150 × 2P (300 × 2P)	
	r/ε 1, /ε 2	M4	1.3 to 1.4	0.5 to 5.5 (20 to 10)	1.25 (16)	

* The wire thickness is set for copper wires at 75°C

Table 2.2 400 V Class Wire Sizes

Inverter Model CIMR-□	Terminal Symbol	Terminal Screws	Tightening Torque (N•m)	Possible Wire Sizes mm ² (AWG)	Recommended Wire Size mm ² (AWG)	Wire Type
G7C40P4	R/L1, S/L2, T/L3, ⊖, ⊕1, ⊕2, B1, B2, U/T1, V/T2, W/T3	M4	1.2 to 1.5	2 to 5.5 (14 to 10)	2 (14)	Power cables, e.g., 600 V vinyl power cables
	⊖					
G7C40P7	R/L1, S/L2, T/L3, ⊖, ⊕1, ⊕2, B1, B2, U/T1, V/T2, W/T3	M4	1.2 to 1.5	2 to 5.5 (14 to 10)	2 (14)	
	⊖					
G7C41P5	R/L1, S/L2, T/L3, ⊖, ⊕1, ⊕2, B1, B2, U/T1, V/T2, W/T3	M4	1.2 to 1.5	2 to 5.5 (14 to 10)	2 (14)	
	⊖					
G7C42P2	R/L1, S/L2, T/L3, ⊖, ⊕1, ⊕2, B1, B2, U/T1, V/T2, W/T3	M4	1.2 to 1.5	2 to 5.5 (14 to 10)	3.5 (12)	
	⊖				2 (14)	
G7C43P7	R/L1, S/L2, T/L3, ⊖, ⊕1, ⊕2, B1, B2, U/T1, V/T2, W/T3	M4	1.2 to 1.5	2 to 5.5 (14 to 10)	3.5 (12)	
	⊖					
G7C45P5	R/L1, S/L2, T/L3, ⊖, ⊕1, ⊕2, B1, B2, U/T1, V/T2, W/T3	M4	1.2 to 1.5	3.5 to 5.5 (12 to 10)	5.5 (10)	
	⊖					
G7C47P5	R/L1, S/L2, T/L3, ⊖, ⊕1, ⊕2, B1, B2, U/T1, V/T2, W/T3	M5	2.5	5.5 to 14 (10 to 6)	8 (8)	
	⊖					
G7C4011	R/L1, S/L2, T/L3, ⊖, ⊕1, ⊕2, B1, B2, U/T1, V/T2, W/T3	M5	2.5	8 to 14 (8 to 6)	8 (8)	
	⊖	M5 (M6)	2.5 (4.0 to 5.0)	5.5 to 14 (10 to 6)	5.5 (10)	
G7C4015	R/L1, S/L2, T/L3, ⊖, ⊕1, ⊕2, U/T1, V/T2, W/T3	M5	4.0 to 5.0	8 to 14 (8 to 6)	8 (8)	
	B1, B2	M5	2.5	8 (8)	8 (8)	
	⊖	M5 (M6)	4.0 to 5.0	8 to 22 (8 to 4)	8 (8)	
G7C4018	R/L1, S/L2, T/L3, ⊖, ⊕1, ⊕3, U/T1, V/T2, W/T3, R1/L11, S1/L21, T1/L31	M6	4.0 to 5.0	14 to 22 (6 to 4)	14 (6)	
	⊖	M8	9.0 to 10.0	14 to 38 (6 to 2)	14 (6)	
G7C4022	R/L1, S/L2, T/L3, ⊖, ⊕1, ⊕3, U/T1, V/T2, W/T3, R1/L11, S1/L21, T1/L31	M6	4.0 to 5.0	22 (4)	22 (4)	
	⊖	M8	9.0 to 10.0	22 to 38 (4 to 2)	22 (4)	
G7C4030	R/L1, S/L2, T/L3, ⊖, ⊕1, U/T1, V/T2, W/T3, R1/L11, S1/L21, T1/L31	M8	9.0 to 10.0	22 to 60 (4 to 1/0)	38 (2)	
	⊕3	M6	4.0 to 5.0	8 to 22 (8 to 4)	-	
	⊖	M8	9.0 to 10.0	22 to 38 (4 to 2)	22 (4)	
G7C4037	R/L1, S/L2, T/L3, ⊖, ⊕1, U/T1, V/T2, W/T3, R1/L11, S1/L21, T1/L31	M8	9.0 to 10.0	30 to 60 (2 to 1/0)	38 (2)	
	⊕3	M6	4.0 to 5.0	8 to 22 (8 to 4)	-	
	⊖	M8	9.0 to 10.0	22 to 38 (4 to 2)	22 (4)	

Inverter Model CIMR-□	Terminal Symbol	Terminal Screws	Tightening Torque (N·m)	Possible Wire Sizes mm ² (AWG)	Recommended Wire Size mm ² (AWG)	Wire Type
G7C4045	R/L1, S/L2, T/L3, ⊖, ⊕1, U/T1, V/T2, W/T3, R1/L11, S1/L21, T1/L31	M8	9.0 to 10.0	50 to 60 (1 to 1/0)	50 (1)	Power cables, e.g., 600 V vinyl power cables
	⊕3	M6	4.0 to 5.0	8 to 22 (8 to 4)	-	
	⊖	M8	9.0 to 10.0	22 to 38 (4 to 2)	22 (4)	
G7C4055	R/L1, S/L2, T/L3, ⊖, ⊕1, U/T1, V/T2, W/T3, R1/L11, S1/L21, T1/L31	M10	17.6 to 22.5	50 to 100 (1/0 to 4/0)	50 (1/0)	
	⊕3	M8	8.8 to 10.8	5.5 to 22 (10 to 4)	-	
	⊖	M10	17.6 to 22.5	38 to 60 (2 to 2/0)	38 (2)	
	r/ϕ1, 200/ϕ2200, 400/ϕ2400	M4	1.3 to 1.4	0.5 to 5.5 (20 to 10)	1.25 (16)	
G7C4075	R/L1, S/L2, T/L3, ⊖, ⊕1, U/T1, V/T2, W/T3, R1/L11, S1/L21, T1/L31	M10	17.6 to 22.5	80 to 100 (3/0 to 4/0)	100 (4/0)	
	⊕3	M8	8.8 to 10.8	8 to 22 (8 to 4)	-	
	⊖	M10	17.6 to 22.5	50 to 100 (1 to 4/0)	50 (1)	
	r/ϕ1, 200/ϕ2200, 400/ϕ2400	M4	1.3 to 1.4	0.5 to 5.5 (20 to 10)	1.25 (16)	
G7C4090	R/L1, S/L2, T/L3, ⊖, ⊕1, U/T1, V/T2, W/T3, R1/L11, S1/L21, T1/L33	M10	17.6 to 22.5	50 to 100 (1/0 to 4/0)	50 × 2P (1/0 × 2P)	
	⊕3	M8	8.8 to 10.8	8 to 60 (8 to 2/0)	-	
	⊖	M10	17.6 to 22.5	60 to 150 (2/0 to 300)	60 (2/0)	
	r/ϕ1, 200/ϕ2200, 400/ϕ2400	M4	1.3 to 1.4	0.5 to 5.5 (20 to 10)	1.25 (16)	
G7C4110	R/L1, S/L2, T/L3, ⊖, ⊕1, U/T1, V/T2, W/T3, R1/L11, S1/L21, T1/L33	M10	17.6 to 22.5	60 to 100 (2/0 to 4/0)	80 × 2P (3/0 × 2P)	
	⊕3	M8	8.8 to 10.8	8 to 60 (8 to 2/0)	-	
	⊖	M10	17.6 to 22.5	100 to 150 (4/0 to 300)	100 (4/0)	
	r/ϕ1, 200/ϕ2200, 400/ϕ2400	M4	1.3 to 1.4	0.5 to 5.5 (20 to 10)	1.25 (16)	
G7C4132	R/L1, S/L2, T/L3, ⊖, ⊕1, U/T1, V/T2, W/T3, R1/L11, S1/L21, T1/L31	M12	31.4 to 39.2	80 to 200 (3/0 to 400)	80 × 2P (3/0 × 2P)	
	⊕3	M8	8.8 to 10.8	8 to 60 (8 to 2/0)	-	
	⊖	M12	31.4 to 39.2	50 to 150 (1/0 to 300)	50 × 2P (1/0 × 2P)	
	r/ϕ1, 200/ϕ2200, 400/ϕ2400	M4	1.3 to 1.4	0.5 to 5.5 (20 to 10)	1.25 (16)	
G7C4160	R/L1, S/L2, T/L3, ⊖, ⊕1, U/T1, V/T2, W/T3, R1/L11, S1/L21, T1/L31	M12	31.4 to 39.2	100 to 200 (4/0 to 400)	100 × 2P (4/0 × 2P)	
	⊕3	M8	8.8 to 10.8	80 to 60 (8 to 2/0)	-	
	⊖	M12	31.4 to 39.2	50 to 150 (1/0 to 300)	50 × 2P (1/0 × 2P)	
	r/ϕ1, 200/ϕ2200, 400/ϕ2400	M4	1.3 to 1.4	0.5 to 5.5 (20 to 10)	1.25 (16)	
G7C4185	Under development					
G7C4220						
G7C4300						

* The wire thickness is set for copper wires at 75°C.

Table 2.3 Closed-loop Connector Sizes (JIS C2805) (200 V Class and 400 V Class)

Wire Thickness (mm ²)	Terminal Screws	Size
0.5	M3.5	1.25 to 3.5
	M4	1.25 to 4
0.75	M3.5	1.25 to 3.5
	M4	1.25 to 4
1.25	M3.5	1.25 to 3.5
	M4	1.25 to 4
2	M3.5	2 to 3.5
	M4	2 to 4
	M5	2 to 5
	M6	2 to 6
	M8	2 to 8
3.5/5.5	M4	5.5 to 4
	M5	5.5 to 5
	M6	5.5 to 6
	M8	5.5 to 8
8	M5	8 to 5
	M6	8 to 6
	M8	8 to 8
14	M6	14 to 6
	M8	14 to 8
22	M6	22 to 6
	M8	22 to 8
30/38	M8	38 to 8
50/60	M8	60 to 8
	M10	60 to 10
80	M10	80 to 10
100		100 to 10
100		100 to 12
150	M12	150 to 12
200		200 to 12
325		M12 x 2
	M16	325 to 16



IMPORTANT

Determine the wire size for the main circuit so that line voltage drop is within 2% of the rated voltage. Line voltage drop is calculated as follows:

$$\text{Line voltage drop (V)} = \sqrt{3} \times \text{wire resistance (W/km)} \times \text{wire length (m)} \times \text{current (A)} \times 10^{-3}$$

◆ Main Circuit Terminal Functions

Main circuit terminal functions are summarized according to terminal symbols in *Table 2.4*. Wire the terminals correctly for the desired purposes.

Table 2.4 Main Circuit Terminal Functions (200 V Class and 400 V Class)

Purpose	Terminal Symbol	Model: CIMR-G7C□	
		200 V Class	400 V Class
Main circuit power input	R/L1, S/L2, T/L3	20P4 to 2110	40P4 to 4160
	R1/L11, S1/L21, T1/L31	2018 to 2110	4018 to 4160
Inverter outputs	U/T1, V/T2, W/T3	20P4 to 2110	40P4 to 4160
DC power input	⊕1, ⊖	20P4 to 2110	40P4 to 4160
Braking Resistor Unit connection	B1, B2	20P4 to 27P5	40P4 to 4015
DC reactor connection	⊕1, ⊕2	20P4 to 2015	40P4 to 4015
Braking Unit connection	⊕3, ⊖	2018 to 2110	4018 to 4160
Ground	⊕	20P4 to 2110	40P4 to 4160

◆ Main Circuit Configurations

The main circuit configurations of the Inverter are shown in *Fig 2.5*.

Table 2.5 Inverter Main Circuit Configurations

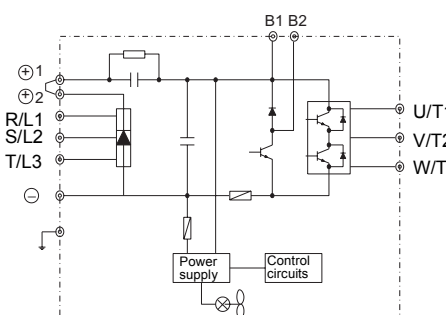
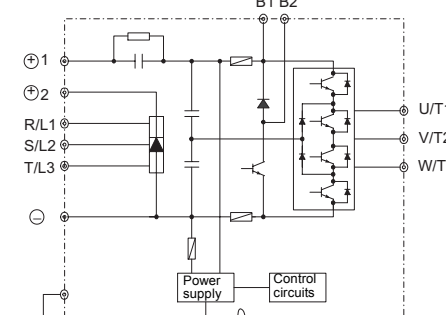
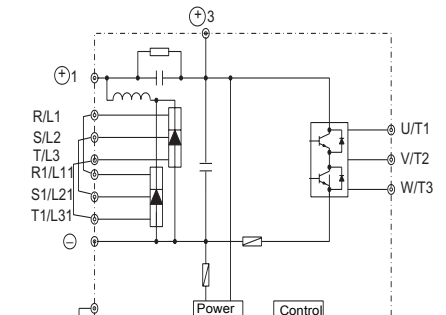
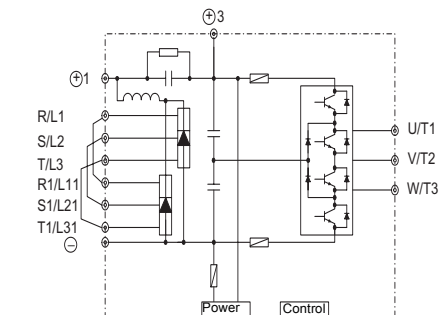
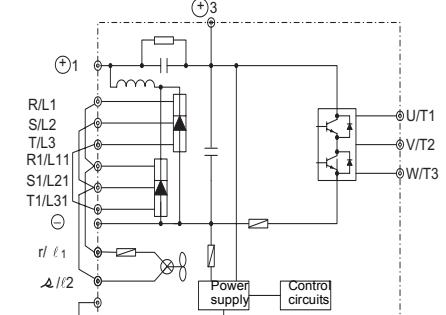
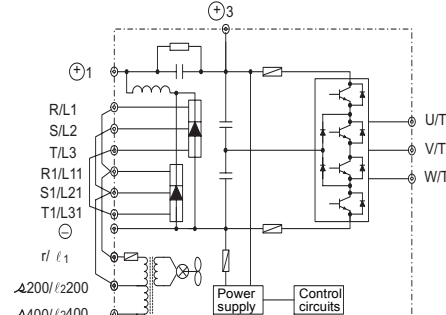
200 V Class	400 V Class
<p style="text-align: center;">CIMR-G7C20P4 to 2015</p> 	<p style="text-align: center;">CIMRG7C40P4 to 4015</p> 
<p style="text-align: center;">CIMR-G7C2018, 2022</p> 	<p style="text-align: center;">CIMR-G7C4018 to 4045</p> 
<p style="text-align: center;">CIMR-G7C2030 to 2110</p> 	<p style="text-align: center;">CIMR-G7C4055 to 4300</p> 

Note Consult your Yaskawa representative before using 12-phase rectification.

◆ Standard Connection Diagrams

Standard Inverter connection diagrams are shown in *Fig 2.5*. These are the same for both 200 V Class and 400 V Class Inverters. The connections depend on the Inverter capacity.

■ CIMR-G7C20P4 to 2015 and 40P4 to 4015

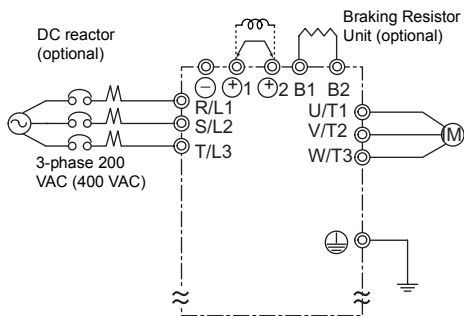

Be sure to remove the short-circuit bar before connecting the DC reactor.

■ CIMR-G7C2018, 2022, and 4018 to 4045

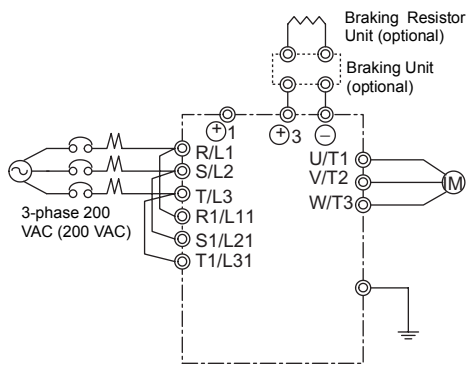

The DC reactor is built in.

■ CIMR-G7C2030 to 2110

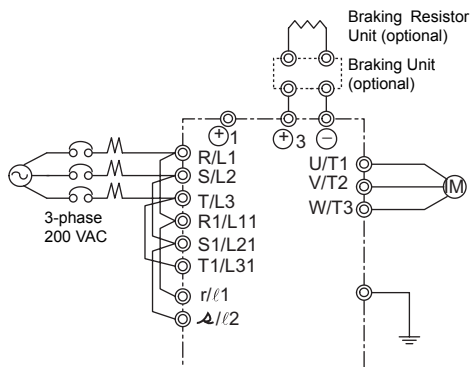

■ CIMR-G7C4055 to 4300

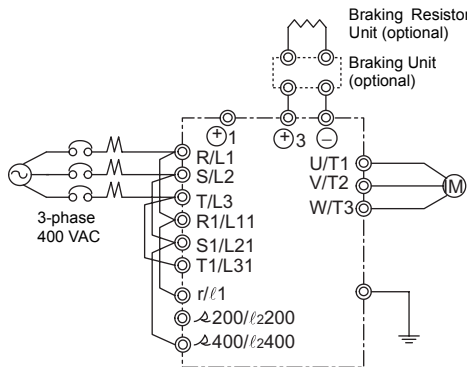

Control power is supplied internally from the main circuit DC power supply for all Inverter models.

Fig 2.5 Main Circuit Terminal Connections

◆ Wiring the Main Circuits

This section describes wiring connections for the main circuit inputs and outputs.

■ Wiring Main Circuit Inputs

Observe the following precautions for the main circuit power supply input.

Installing a Molded-case Circuit Breaker

Always connect the power input terminals (R, S, and T) and power supply via a molded-case circuit breaker (MCCB) suitable for the Inverter.

- Choose an MCCB with a capacity of 1.5 to 2 times the Inverter's rated current.
- For the MCCB's time characteristics, be sure to consider the Inverter's overload protection (one minute at 150% of the rated output current).
- If the same MCCB is to be used for more than one Inverter, or other devices, set up a sequence so that the power supply will be turned OFF by a fault output, as shown in Fig 2.6.

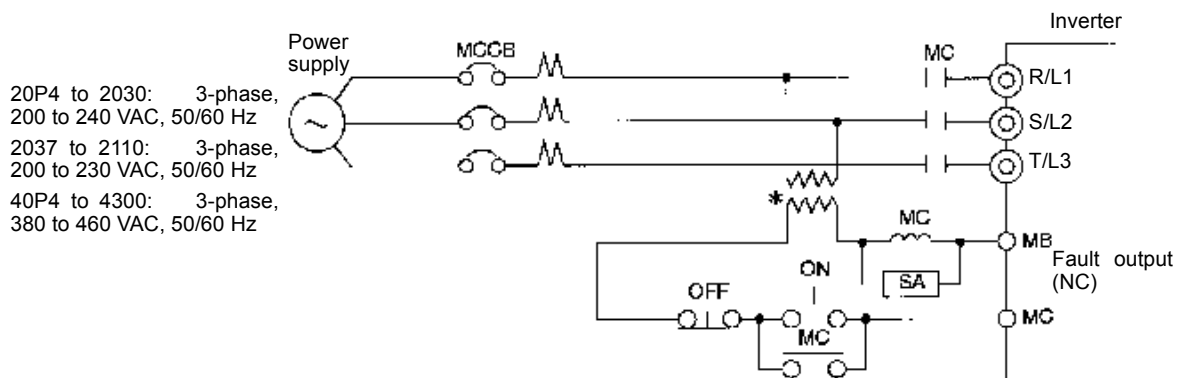

* For 400 V class Inverters, connect a 400/200 V transformer.

Fig 2.6 MCCB Installation

Installing a Ground Fault Interrupter

Inverter outputs use high-speed switching, so high-frequency leakage current is generated. Therefore, at the Inverter primary side, use a ground fault interrupter to detect only the leakage current in the frequency range that is hazardous to humans and exclude high-frequency leakage current.

- For the special-purpose ground fault interrupter for Inverters, choose a ground fault interrupter with a sensitivity amperage of at least 30 mA per Inverter.
- When using a general ground fault interrupter, choose a ground fault interrupter with a sensitivity amperage of 200 mA or more per Inverter and with an operating time of 0.1 s or more.

Installing a Magnetic Contactor

If the power supply for the main circuit is to be shut off during a sequence, a magnetic contactor can be used. When a magnetic contactor is installed on the primary side of the main circuit to forcibly stop the Inverter, however, the regenerative braking does not work and the Inverter will coast to a stop.

- The Inverter can be started and stopped by opening and closing the magnetic contactor on the primary side. Frequently opening and closing the magnetic contactor, however, may cause the Inverter to break down. Start and stop the Inverter at most once every 30 minutes.
- When the Inverter is operated with the Digital Operator, automatic operation cannot be performed after recovery from a power interruption.
- If the Braking Resistor Unit is used, program the sequence so that the magnetic contactor is turned OFF by the contact of the Unit's thermal overload relay.

Connecting Input Power Supply to the Terminal Block

Input power supply can be connected to any terminal R, S or T on the terminal block; the phase sequence of input power supply is irrelevant to the phase sequence.

Installing an AC Reactor

If the Inverter is connected to a large-capacity power transformer (600 kW or more) or the phase advancing capacitor is switched, an excessive peak current may flow through the input power circuit, causing the converter unit to break down.

To prevent this, install an optional AC Reactor on the input side of the Inverter or a DC reactor to the DC reactor connection terminals.

This also improves the power factor on the power supply side.

Installing a Surge Absorber

Always use a surge absorber or diode for inductive loads near the Inverter. These inductive loads include magnetic contactors, electromagnetic relays, solenoid valves, solenoids, and magnetic brakes.

Installing a Noise Filter on Power Supply Side

Install a noise filter to eliminate noise transmitted between the power line and the Inverter.

- Correct Noise Filter Installation

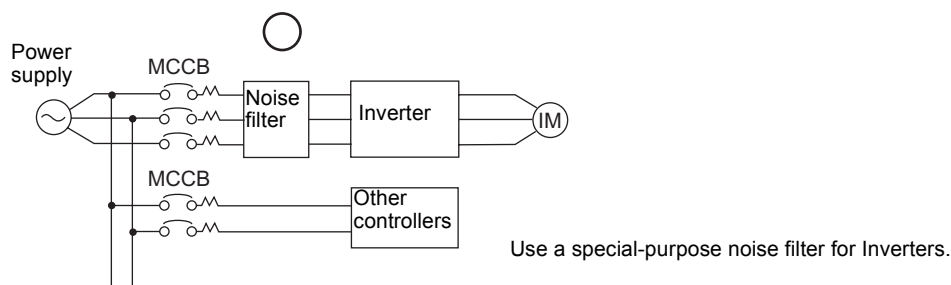

Fig 2.7 Correct Power supply Noise Filter Installation

- Incorrect Noise Filter Installation

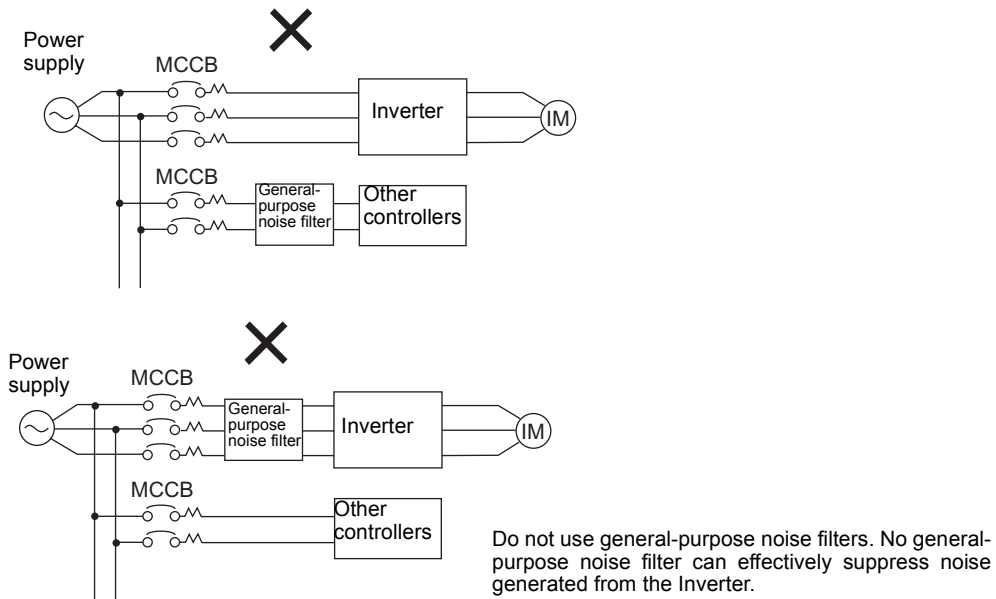

Fig 2.8 Incorrect Power supply Noise Filter Installation

■Wiring the Output Side of Main Circuit

Observe the following precautions when wiring the main output circuits.

Connecting the Inverter and Motor

Connect output terminals U, V, and W to motor lead wires U, V, and W, respectively.

Check that the motor rotates forward with the forward run command. Switch over any two of the output terminals to each other and reconnect if the motor rotates in reverse with the forward run command.

Never Connect a Power Supply to Output Terminals

Never connect a power supply to output terminals U, V, and W. If voltage is applied to the output terminals, the internal circuits of the Inverter will be damaged.

Never Short or Ground Output Terminals

If the output terminals are touched with bare hands or the output wires come into contact with the Inverter casing, an electric shock or grounding will occur. This is extremely hazardous. Do not short the output wires.

Do Not Use a Phase Advancing Capacitor or Noise Filter

Never connect a phase advancing capacitor or LC/RC noise filter to an output circuit. The high-frequency components of the Inverter output may result in overheating or damage to these part or may result in damage to the Inverter or cause other parts to burn.

Do Not Use an Electromagnetic Switch

Never connect an electromagnetic switch (MC) between the Inverter and motor and turn it ON or OFF during operation. If the MC is turned ON while the Inverter is operating, a large inrush current will be created and the overcurrent protection in the Inverter will operate.

When using an MC to switch to a commercial power supply, stop the Inverter and motor before operating the MC. Use the speed search function if the MC is operated during operation. If measures for momentary power interrupts are required, use a delayed release MC.

Installing a Thermal Overload Relay

This Inverter has an electronic thermal protection function to protect the motor from overheating. If, however, more than one motor is operated with one Inverter or a multi-polar motor is used, always install a thermal relay (THR) between the Inverter and the motor and set L1-01 to 0 (no motor protection). The sequence should be designed so that the contacts of the thermal overload relay turn OFF the magnetic contactor on the main circuit inputs.

Installing a Noise Filter on Output Side

Connect a noise filter to the output side of the Inverter to reduce radio noise and inductive noise.

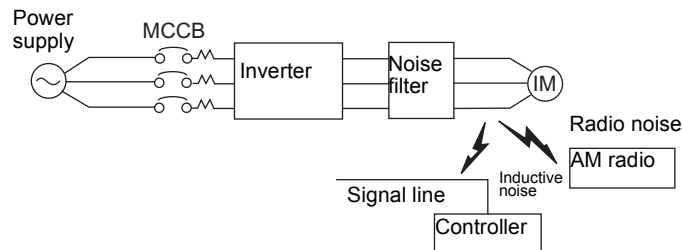

- Inductive Noise: Electromagnetic induction generates noise on the signal line, causing the controller to malfunction.
- Radio Noise: Electromagnetic waves from the Inverter and cables cause the broadcasting radio receiver to make noise.

Fig 2.9 Installing a Noise Filter on the Output Side

Countermeasures Against Inductive Noise

As described previously, a noise filter can be used to prevent inductive noise from being generated on the output side. Alternatively, cables can be routed through a grounded metal pipe to prevent inductive noise. Keeping the metal pipe at least 30 cm away from the signal line considerably reduces inductive noise.

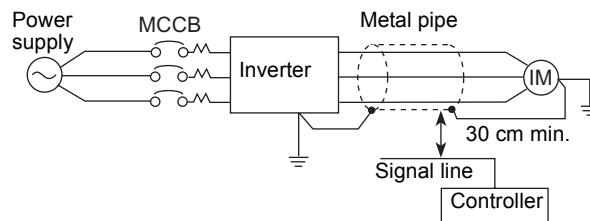

Fig 2.10 Countermeasures Against Inductive Noise

Countermeasures Against Radio Interference

Radio noise is generated from the Inverter as well as from the input and output lines. To reduce radio noise, install noise filters on both input and output sides, and also install the Inverter in a totally enclosed steel box.

The cable between the Inverter and the motor should be as short as possible.

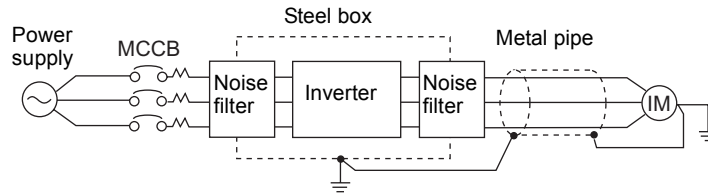

Fig 2.11 Countermeasures Against Radio Interference

Cable Length between Inverter and Motor

If the cable between the Inverter and the motor is long, the high-frequency leakage current will increase, causing the Inverter output current to increase as well. This may affect peripheral devices. To prevent this, adjust the carrier frequency (set in C6-01, C6-02) as shown in *Table 2.6*. (For details, refer to *Chapter 5 User Constants*.)

Table 2.6 Cable Length between Inverter and Motor

Cable length	50 m max.	100 m max.	More than 100 m
Carrier frequency	15 kHz max.	10 kHz max.	5 kHz max.

■ Ground Wiring

Observe the following precautions when wiring the ground line.

- Always use the ground terminal of the 200 V Inverter with a ground resistance of less than 100 Ω and that of the 400 V Inverter with a ground resistance of less than 10 Ω .
- Do not share the ground wire with other devices, such as welding machines or power tools.
- Always use a ground wire that complies with technical standards on electrical equipment and minimize the length of the ground wire.

Leakage current flows through the Inverter. Therefore, if the distance between the ground electrode and the ground terminal is too long, potential on the ground terminal of the Inverter will become unstable.

- When using more than one Inverter, be careful not to loop the ground wire.

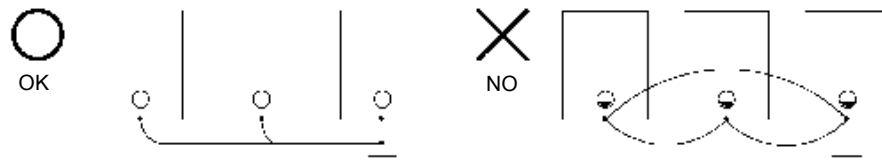

Fig 2.12 Ground Wiring

■Connecting the Braking Resistor (ERF)

A Braking Resistor that mounts to the Inverter can be used with 200 V and 400 V Class Inverters with outputs from 0.4 to 3.7 kW.

Connect the braking resistor as shown in *Fig 2.13*.

Table 2.7

L8-01 (Protect selection for internal DB resistor)	1 (Enables overheat protection)
L3-04 (Stall prevention selection during deceleration) (Select either one of them.)	0 (Disables stall prevention function)
	3 (Enables stall prevention function with braking resistor)

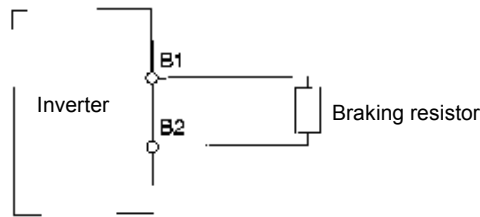

Fig 2.13 Connecting the Braking Resistor



The braking resistor connection terminals are B1 and B2. Do not connect to any other terminals. Connecting to any terminals other than B1 or B2 can cause the resistor to overheat, resulting in damage to the equipment.

■Connecting the Braking Resistor Unit (LKEB) and Braking Unit (CDBR)

Use the following settings when using a Braking Resistor Unit. Refer to *User Constants* on page 10-19 for connection methods for a Braking Resistor Unit.

A Braking Resistor that mounts to the Inverter can also be used with Inverters with outputs from 0.4 to 3.7 kW.

Table 2.8

L8-01 (Protect selection for internal DB resistor)	0 (Disables overheat protection)
L3-04 (Stall prevention selection during deceleration) (Select either one of them.)	0 (Disables stall prevention function)
	3 (Enables stall prevention function with braking resistor)

L8-01 is used when a braking resistor without thermal overload relay trip contacts (ERF type mounted to Inverter) is connected.

The Braking Resistor Unit cannot be used and the deceleration time cannot be shortened by the Inverter if L3-04 is set to 1 (i.e., if stall prevention is enabled for deceleration).

Wiring Control Circuit Terminals

◆ Wire Sizes and Closed-loop Connectors

For remote operation using analog signals, keep the control line length between the Digital Operator or operation signals and the Inverter to 50 m or less, and separate the lines from high-power lines (main circuits or relay sequence circuits) to reduce induction from peripheral devices.

When setting frequencies from an external frequency setter (and not from a Digital Operator), used shielded twisted-pair wires and ground the shield to terminal E (G), as shown in the following diagram.

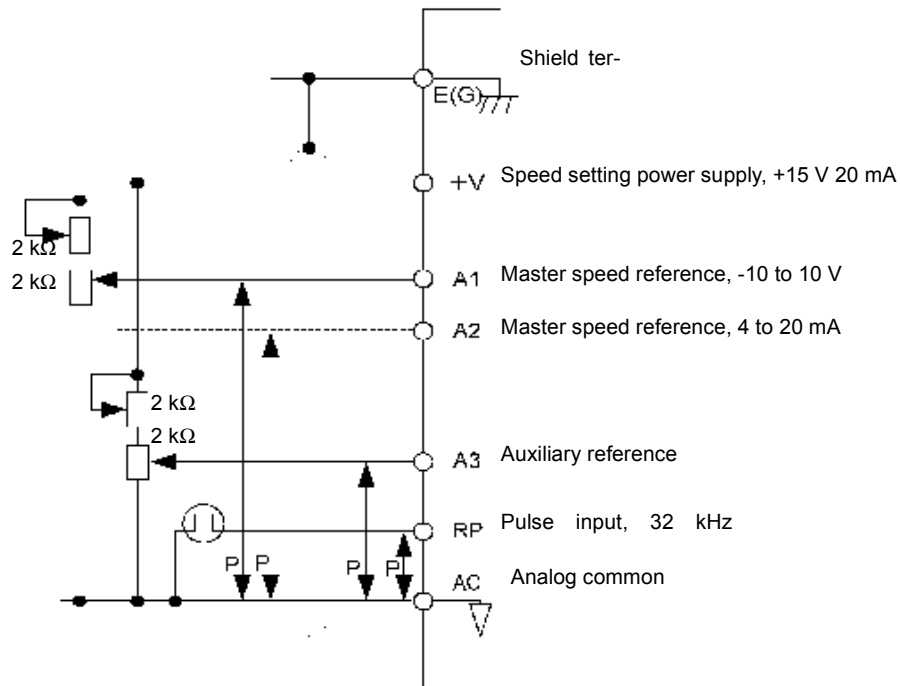

Fig 2.14

Terminal numbers and wire sizes are shown in *Table 2.9*.

Table 2.9 Terminal Numbers and Wire Sizes (Same for all Models)

Terminals	Terminal Screws	Tightening Torque (N•m)	Possible Wire Sizes mm ² (AWG)	Recommended Wire Size mm ² (AWG)	Wire Type
FM, AC, AM, M3, M4, SC, A1, A2, A3, +V, -V, S1, S2, S3, S4, S5, S6, S7, S8, MA, MB, MC, M1, M2, P3, C3, P4, C4, MP, RP, R+, R-, S9, S10, S11, S12, S+, S-, IG, SN, SP	Phoenix type	0.5 to 0.6	Single wire ^{*3} : 0.14 to 2.5 Stranded wire: 0.14 to 1.5 (26 to 14)	0.75 (18)	<ul style="list-style-type: none"> • Shielded, twisted-pair wire^{*1} • Shielded, polyethylene-covered, vinyl sheath cable (KPEV-S by Hitachi Electrical Wire or equivalent)
E (G)	M3.5	0.8 to 1.0	0.5 to 2 ^{*2} (20 to 14)	1.25 (12)	

* 1. Use shielded twisted-pair cables to input an external frequency reference.

* 2. Refer to *Table 2.3 Close-loop Connector Sizes* for suitable closed-loop crimp terminal sizes for the wires.

* 3. We recommend using straight solderless terminal on signal lines to simplify wiring and improve reliability.

■ Straight Solderless Terminals for Signal Lines

Models and sizes of straight solderless terminal are shown in the following table.

Table 2.10 Straight Solderless Terminal Sizes

Wire Size mm ² (AWG)	Model	d1	d2	L	Manufacturer
0.25 (24)	AI 0.25 - 8YE	0.8	2	12.5	Phoenix Contact
0.5 (20)	AI 0.5 - 8WH	1.1	2.5	14	
0.75 (18)	AI 0.75 - 8GY	1.3	2.8	14	
1.25 (16)	AI 1.5 - 8BK	1.8	3.4	14	
2 (14)	AI 2.5 - 8BU	2.3	4.2	14	

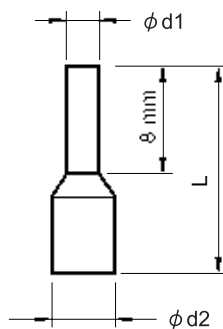

Fig 2.15 Straight Solderless Terminal Sizes

■ Wiring Method

Use the following procedure to connect wires to the terminal block.

1. Loosen the terminal screws with a thin-slot screwdriver.
2. Insert the wires from underneath the terminal block.
3. Tighten the terminal screws firmly.

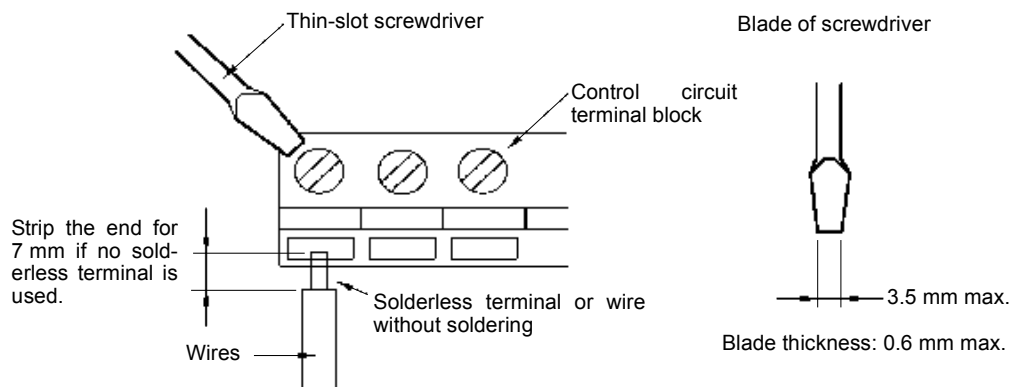

Fig 2.16 Connecting Wires to Terminal Block

◆ Control Circuit Terminal Functions

The functions of the control circuit terminals are shown in *Table 2.11*. Use the appropriate terminals for the correct purposes.

Table 2.11 Control Circuit Terminals

Type	No.	Signal Name	Function	Signal Level
Se- quence input signals	S1	Forward run/stop command	Forward run when ON; stopped when OFF.	24 VDC, 8 mA Photocoupler isolation
	S2	Reverse run/stop command	Reverse run when ON; stopped when OFF.	
	S3	Multi-function input 1 ^{*1}	Factory setting: External fault when ON.	
	S4	Multi-function input 2 ^{*1}	Factory setting: Fault reset when ON.	
	S5	Multi-function input 3 ^{*1}	Factory setting: Multi-speed speed reference 1 effective when ON.	
	S6	Multi-function input 4 ^{*1}	Factory setting: Multi-speed speed reference 2 effective when ON.	
	S7	Multi-function input 5 ^{*1}	Factory setting: Jog frequency selected when ON.	
	S8	Multi-function input 6 ^{*1}	Factory setting: External baseblock when ON.	
	S9	Multi-function input 7 ^{*1}	Factory setting: Multi-speed speed reference 3 effective when ON.	
	S10	Multi-function input 8 ^{*1}	Factory setting: Multi-speed speed reference 4 effective when ON.	
	S11	Multi-function input 9 ^{*1}	Factory setting: Acceleration/deceleration time selected when ON.	
	S12	Multi-function input 10 ^{*1}	Factory setting: Emergency stop (NO contact) when ON.	
	SC	Sequence input common	-	
Analog input signals	+V	+15 V power output	+15 V power supply for analog references	+15 V (Max. current: 20 mA)
	-V	-15 V power output	-15 V power supply for analog references	-15 V (Max. current: 20 mA)
	A1	Master speed frequency reference	-10 to +10 V/-100 to 100% 0 to +10 V/100%	-10 to +10 V, 0 to +10 V (Input impedance: 20 kΩ)
	A2	Multi-function analog input	4 to 20 mA/100%, -10 to +10 V/-100 to +100%, 0 to +10 V/100% Factory setting: Added to terminal A1 (H3-09 = 0)	4 to 20 mA (Input impedance: 250 Ω)
	A3	Multi-function analog input	4 to 20 mA/100%, -10 to +10 V/-100 to +100%, 0 to +10 V/100% Factory setting: Analog speed 2 (H3-05 = 2)	4 to 20 mA (Input impedance: 250 Ω)
	AC	Analog reference common	0 V	-
E(G)	Shield wire, optional ground line connection point	-	-	

Table 2.11 Control Circuit Terminals (Continued)

Type	No.	Signal Name	Function	Signal Level
Photo-coupler outputs	P3	Multi-function PHC output 3	Factory setting: Ready for operation when ON.	50 mA max. at 48 VDC*2
	C3			
	P4	Multi-function PHC output 4	Factory setting: FOUT frequency detected when ON.	
	C4			
Relay outputs	MA	Fault output signal (NO contact)	Fault when CLOSED across MA and MC Fault when OPEN across MB and MC	Dry contacts Contact capacity: 1 A max. at 250 VAC 1 A max. at 30 VDC
	MB	Fault output signal (NC contact)		
	MC	Relay contact output common	-	
	M1	Multi-function contact output (NO contact)	Factory setting: Operating Operating when ON across M1 and M2.	
	M2			
	M3	Multi-function contact output 2	Factory setting: Zero speed Zero speed level (b2-01) or below when ON.	
	M4			
M5	Multi-function contact output 3	Factory setting: Frequency agreement detection Frequency within 2 Hz of set frequency when ON.		
M6				
Analog monitor outputs	FM	Multi-function analog monitor 1	Factory setting: Output frequency 0 to 10 V/100% frequency	0 to +10 VDC \pm 5% 2 mA max.
	AM	Multi-function analog monitor 2	Factory setting: Current monitor 5 V/Inverter's rated current	
	AC	Analog common	-	
Pulse I/O	RP	Multi-function pulse input*3	Factory setting: Frequency reference input (H6-01 = 0)	0 to 32 kHz (3 k Ω)
	MP	Multi-function pulse monitor	Factory setting: Output frequency (H6-06 = 2)	0 to 32 kHz (2.2 k Ω)
RS-485/422	R+	MEMOBUS communications input	For 2-wire RS-485, short R+ and S+ as well as R- and S-.	Differential input, PHC isolation
	R-			
	S+	MEMOBUS communications output		Differential output, PHC isolation
	S-			
	IG	Communications shield wire		-

* 1. For a 3-wire sequence, the default settings are a 3-wire sequence for S5, multi-step speed setting 1 for S6 and multi-step speed setting 2 for S7.

* 2. When driving a reactive load, such as a relay coil, always insert a flywheel diode as shown in Fig 2.17.

* 3. Pulse input specifications are given in the following table.

Low level voltage	0.0 to 0.8 V
High level voltage	3.5 to 13.2 V
H duty	30% to 70%
Pulse frequency	0 to 32 kHz

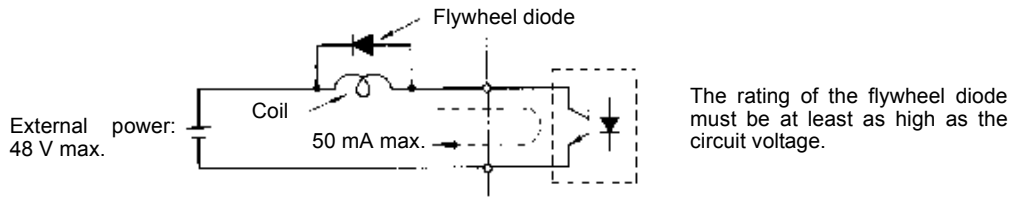

Fig 2.17 Flywheel Diode Connection

■ Shunt Connector CN5 and DIP Switch S1

The shunt connector CN 5 and DIP switch S1 are described in this section.

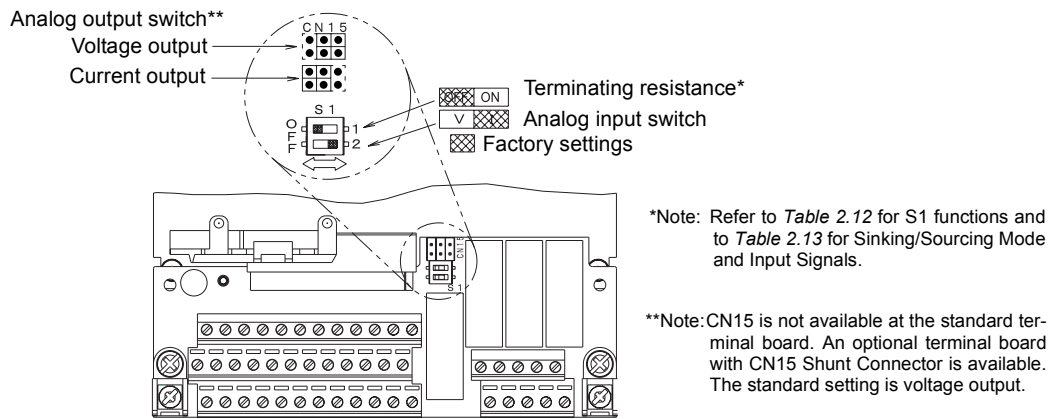

Fig 2.18 Shunt Connector CN5 and DIP Switch S1

The functions of DIP switch S1 are shown in the following table.

Table 2.12 DIP Switch S1

Name	Function	Setting
S1-1	RS-485 and RS-422 terminating resistance	OFF: No terminating resistance ON: Terminating resistance of 110 Ω
S1-2	Input method for analog input A2	OFF: 0 to 10 V (internal resistance: 20 kΩ) ON: 4 to 20 mA (internal resistance: 250 Ω)

■ Sinking/Sourcing Mode

The input terminal logic can be switched between sinking mode (0-V common) and sourcing mode (+24-V common) by using the terminals SN, SC, and SP. An external 24-V power supply is also supported, providing more freedom in signal input methods.

Table 2.13 Sinking/Sourcing Mode and Input Signals

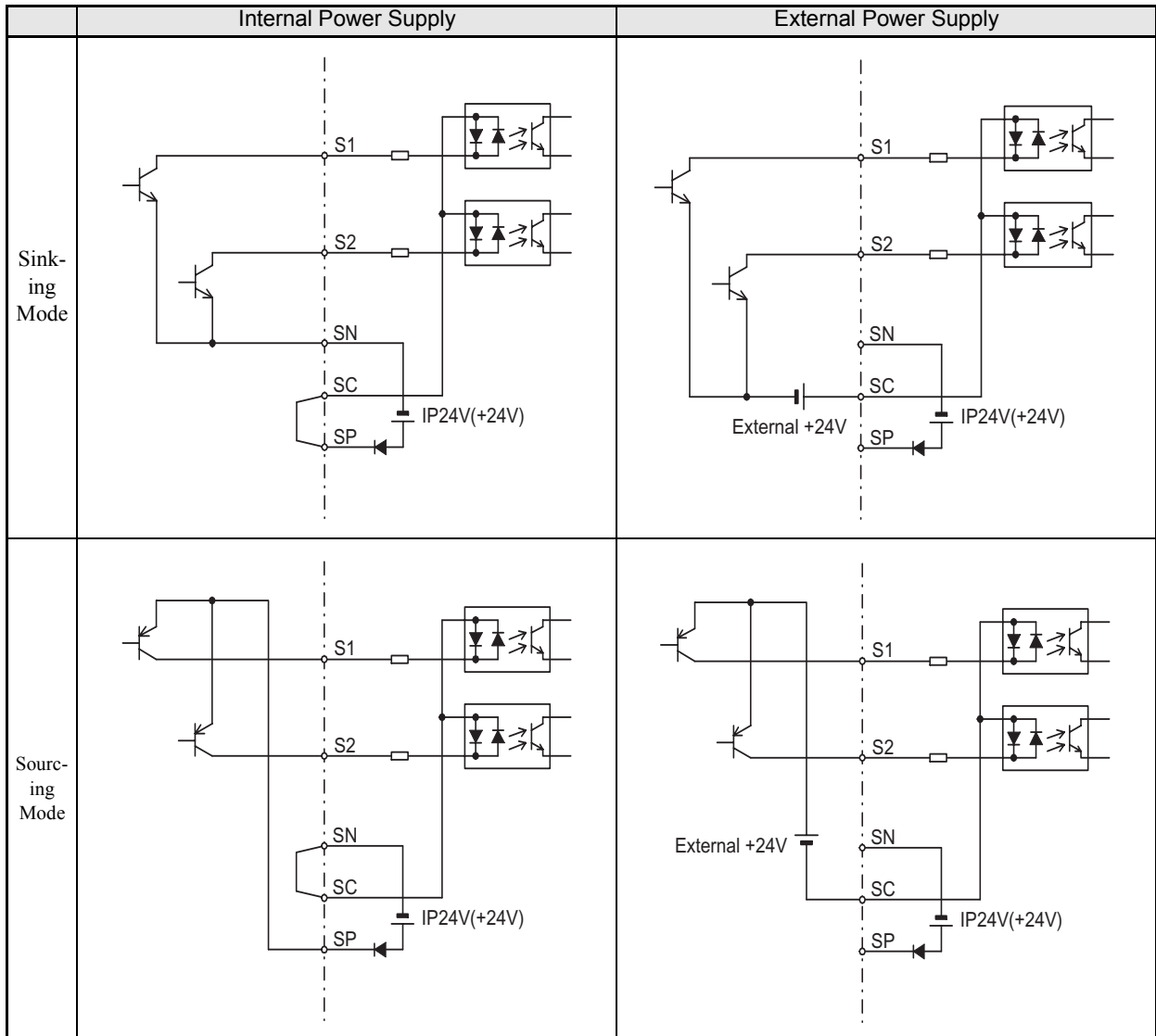

◆ Control Circuit Terminal Connections

Connections to Inverter control circuit terminals are shown in *Fig 2.19*.

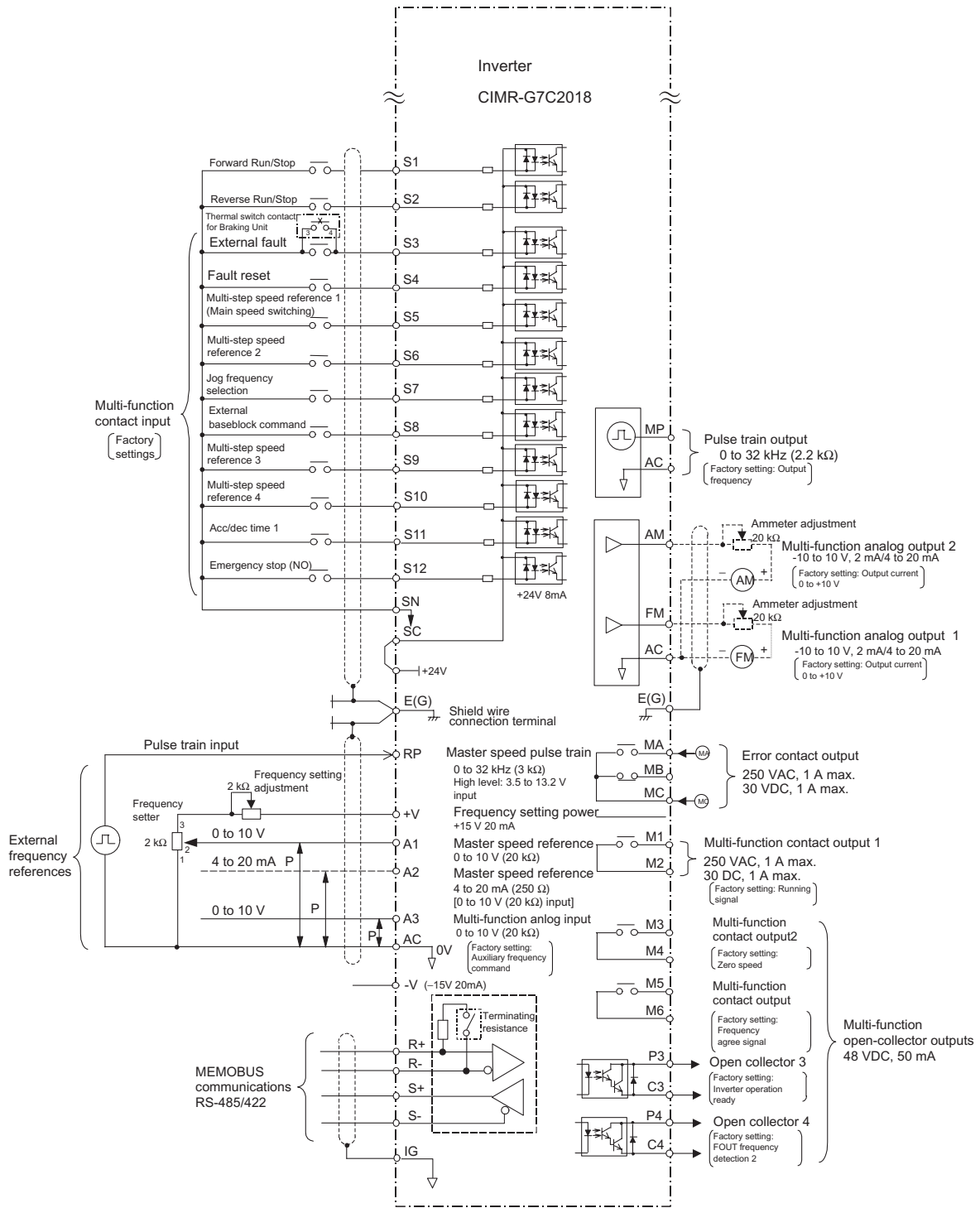

Fig 2.19 Control Circuit Terminal Connections

◆ Control Circuit Wiring Precautions

Observe the following precautions when wiring control circuits.

- Separate control circuit wiring from main circuit wiring (terminals R/L1, S/L2, T/L3, B1, B2, U/T1, V/T2, W/T3, ⊖, ⊕1, ⊕2, and ⊕3) and other high-power lines.
- Separate wiring for control circuit terminals MA, MB, MC, M1, and M2 (contact outputs) from wiring to other control circuit terminals.
- Use twisted-pair or shielded twisted-pair cables for control circuits to prevent operating faults. Process cable ends as shown in *Fig 2.20*.
- Connect the shield wire to terminal E (G).
- Insulate the shield with tape to prevent contact with other signal lines and equipment.

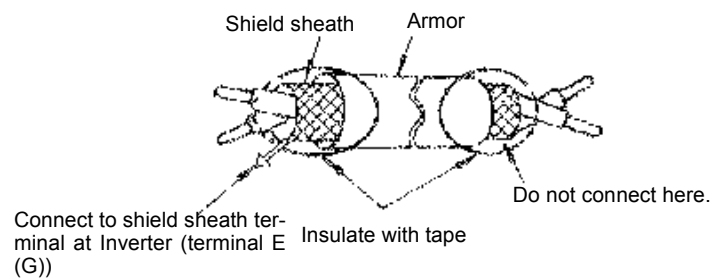

Fig 2.20 Processing the Ends of Twisted-pair Cables

Wiring Check

◆ Checks

Check all wiring after wiring has been completed. Do not perform a buzzer check on control circuits. Perform the following checks on the wiring.

- Is all wiring correct?
- Have any wire clippings, screws, or other foreign material been left?
- Are all screws tight?
- Are any wire ends contacting other terminals?

Installing and Wiring Option Cards

◆ Option Card Models and Specifications

Up to three Option Cards can be mounted in the Inverter. You can mount up one Card into each of the three places on the controller card (A, C, and D) shown in *Fig 2.21*.

Table 2.14 lists the type of Option Cards and their specifications.

Table 2.14 Option Card Specifications

Card	Model	Specifications	Mounting Location
PG Speed Control Cards	PG-A2	Serial open-collector/complimentary inputs	A
	PG-B2	Phase A/B complimentary inputs	A
	PG-D2	Single line-driver inputs	A
	PG-X2	Phase A/B line-driver inputs	A
Speed Reference Cards	AI-14U	Input signal levels 0 to 10 V DC (20 k Ω), 1 channel 4 to 20 mA (250 Ω), 1 channel Input resolution: 14-bit	C
	AI-14B	Input signal levels 0 to 10 V DC (20 k Ω) 4 to 20 mA (250 Ω), 3 channels Input resolution: 13-bit with sign bit	C
	DI-08	8-bit digital speed reference setting	C
	DI-16H2	16-bit digital speed reference setting	C
DeviceNet Communications Card	SI-N	DeviceNet communications support	C
Profibus-DP Communications Card	SI-P	Profibus-DP communications support	C
InterBus-S Communications Card	SI-R	InterBus-S communications support	C
Analog Monitor Card	AO-08	8-bit analog outputs, 2 channels	D
	AO-12	12-bit analog outputs, 2 channels	D
Digital Output Card	DO-08	Six photocoupler outputs and 2 relay outputs	D
	DO-02C	2 relay outputs	D

◆ Installation

Before mounting an Option Card, remove the terminal cover and be sure that the charge indicator inside the Inverter is not lit. After confirming that the charge indicator is not lit, remove the Digital Operator and front cover and then mount the Option Card.

Refer to documentation provided with the Option Card for actual mounting instructions for option slots A, C, and D.

■ Preventing C and D Option Card Connectors from Rising

After installing an Option Card into slot C or D, insert an Option Clip to prevent the side with the connector from rising. The Option Clip can be easily removed by holding onto the protruding portion of the Clip and pulling it out.

Remove the Option Clip before installing an Option Card into slot C or D. The Option Card can not be installed completely and may not function properly if it is installed with the Option Clip attached.

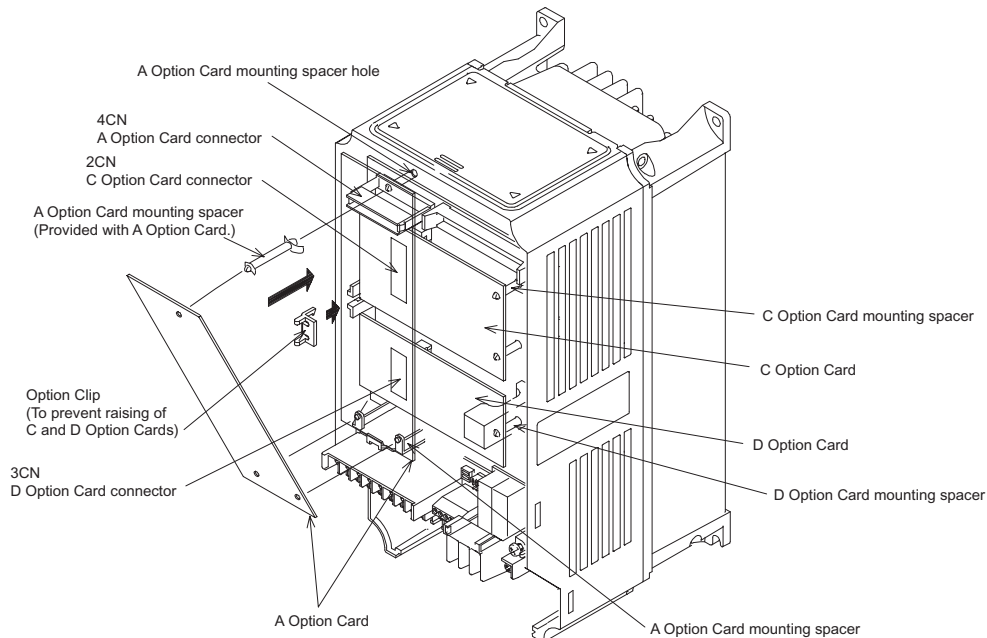

Fig 2.21 Mounting Option Cards

◆ PG Speed Control Card Terminals and Specifications

The terminal specifications for the PG Speed Control Cards are given in the following tables.

■ PG-A2

The terminal specifications for the PG-A2 are given in the following table.

Table 2.15 PG-A2 Terminal Specifications

Terminal	No.	Contents	Specifications
TA1	1	Power supply for pulse generator	12 VDC ($\pm 5\%$), 200 mA max.
	2		0 VDC (GND for power supply)
	3	+12 V/open collector switching terminal	Terminal for switching between 12 V voltage input and open collector input. For open collector input, short across 3 and 4.
	4		
	5	Pulse input terminal	H: +4 to 12 V; L: +1 V max. (Maximum response frequency: 30 kHz)
	6		Pulse input common
	7	Pulse motor output terminal	12 VDC ($\pm 10\%$), 20 mA max.
	8		Pulse monitor output common
TA2	(E)	Shield connection terminal	-

■PG-B2

The terminal specifications for the PG-B2 are given in the following table.

Table 2.16 PG-B2 Terminal Specifications

Terminal	No.	Contents	Specifications
TA1	1	Power supply for pulse generator	12 VDC ($\pm 5\%$), 200 mA max.
	2		0 VDC (GND for power supply)
	3	A-phase pulse input terminal	H: +8 to 12 V L: +1 V max. (Maximum response frequency: 30 kHz)
	4		Pulse input common
	5	B-phase pulse input terminal	H: +8 to 12 V L: +1 V max. (Maximum response frequency: 30 kHz)
	6		Pulse input common
TA2	1	A-phase monitor output terminal	Open collector output, 24 VDC, 30 mA max.
	2		A-phase monitor output common
	3	B-phase monitor output terminal	Open collector output, 24 VDC, 30 mA max.
	4		B-phase monitor output common
TA3	(E)	Shield connection terminal	-

■PG-D2

The terminal specifications for the PG-D2 are given in the following table.

Table 2.17 PG-D2 Terminal Specifications

Terminal	No.	Contents	Specifications
TA1	1	Power supply for pulse generator	12 VDC ($\pm 5\%$), 200 mA max.*
	2		0 VDC (GND for power supply)
	3		5 VDC ($\pm 5\%$), 200 mA max.*
	4	Pulse input + terminal	Line driver input (RS-422 level input)
	5	Pulse input - terminal	Maximum response frequency: 300 kHz
	6	Common terminal	-
	7	Pulse monitor output + terminal	Line driver output (RS-422 level output)
	8	Pulse monitor output - terminal	
TA2	(E)	Shield connection terminal	-

* 5 VDC and 12 VDC cannot be used at the same time.

■ PG-X2

The terminal specifications for the PG-X2 are given in the following table.

Table 2.18 PG-X2 Terminal Specifications

Terminal	No.	Contents	Specifications
TA1	1	Power supply for pulse generator	12 VDC ($\pm 5\%$), 200 mA max.*
	2		0 VDC (GND for power supply)
	3		5 VDC ($\pm 5\%$), 200 mA max.*
	4	A-phase + input terminal	Line driver input (RS-422 level input) Maximum response frequency: 300 kHz
	5	A-phase - input terminal	
	6	B-phase + input terminal	
	7	B-phase - input terminal	
	8	Z-phase + input terminal	
	9	Z-phase - input terminal	
	10	Common terminal	0 VDC (GND for power supply)
TA2	1	A-phase + output terminal	Line driver output (RS-422 level output)
	2	A-phase - output terminal	
	3	B-phase + output terminal	
	4	B-phase - output terminal	
	5	Z-phase + output terminal	
	6	Z-phase - output terminal	
	7	Control circuit common	Control circuit GND
TA3	(E)	Shield connection terminal	-

* 5 VDC and 12 VDC cannot be used at the same time.

◆ Wiring

Wiring examples are provided in the following illustrations for the Control Cards.

■ Wiring the PG-A2

Wiring examples are provided in the following illustrations for the PG-A2.

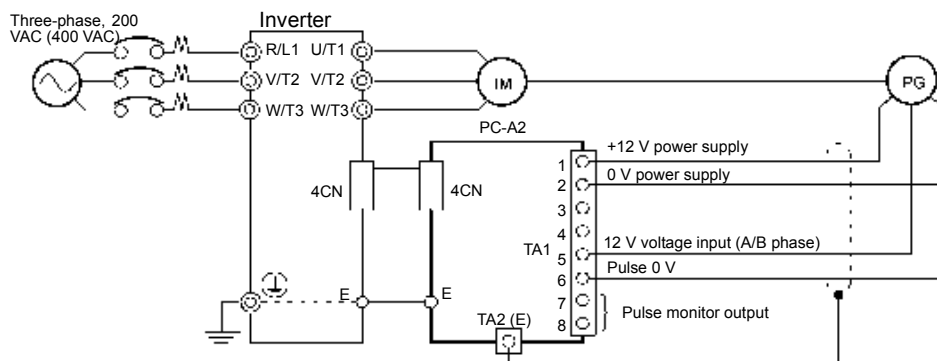
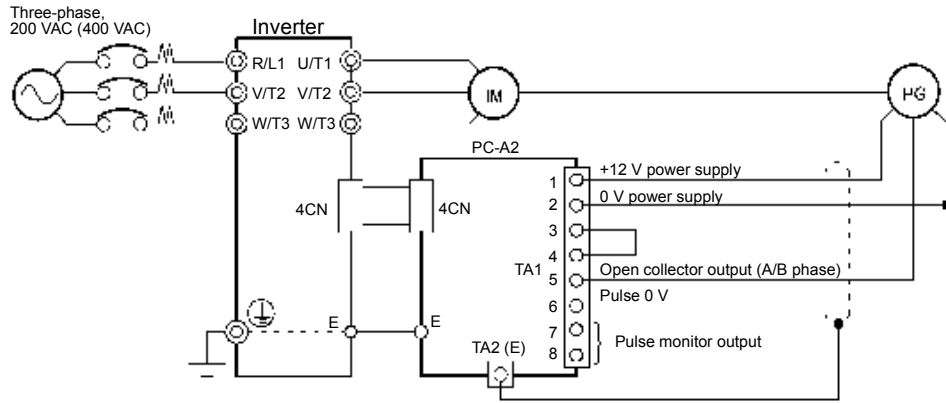

Fig 2.22 Wiring a 12 V Voltage Input



- Shielded twisted-pair wires must be used for signal lines.
- Do not use the pulse generator's power supply for anything other than the pulse generator (encoder). Using it for another purpose can cause malfunctions due to noise.
- The length of the pulse generator's wiring must not be more than 100 meters.

2

Fig 2.23 Wiring an Open-collector Input

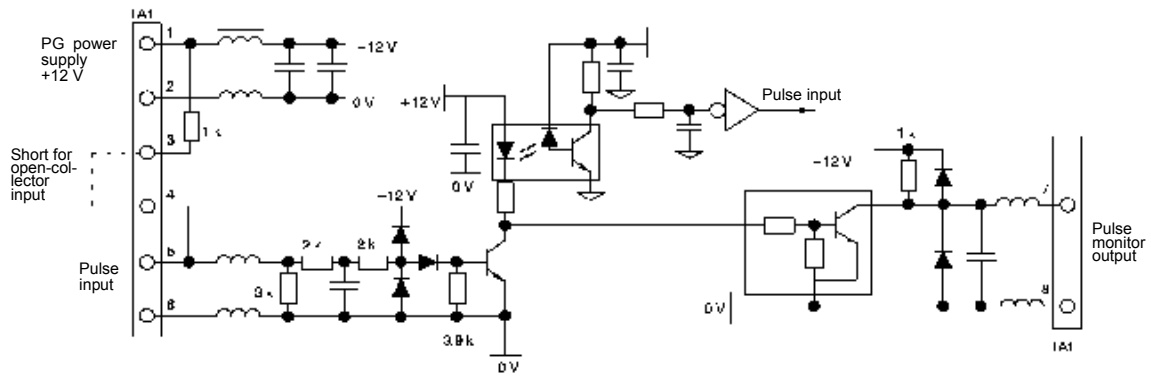
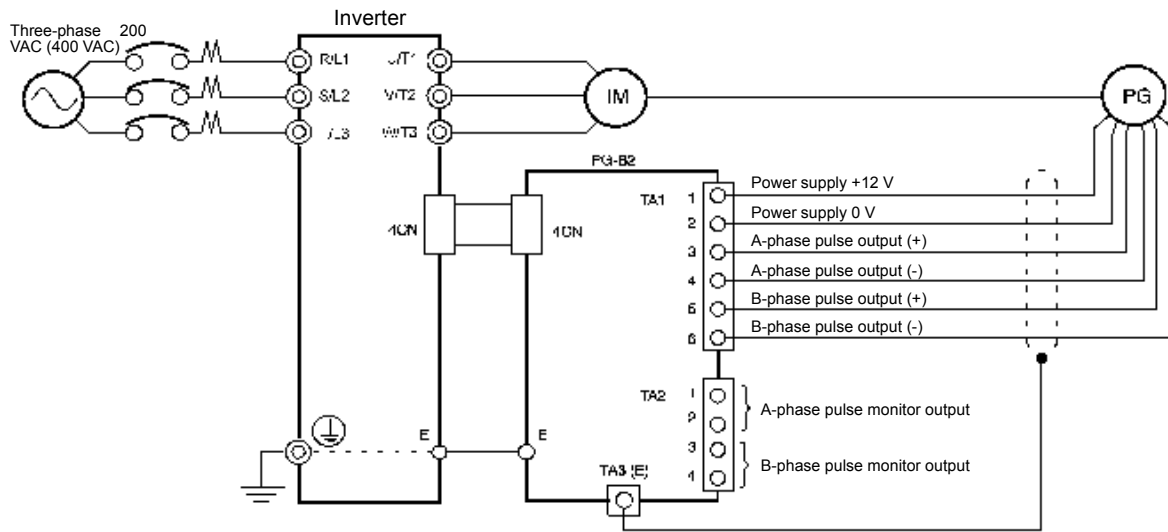

Fig 2.24 I/O Circuit Configuration of the PG-A2

■ Wiring the PG-B2

Wiring examples are provided in the following illustrations for the PG-B2.



- Shielded twisted-pair wires must be used for signal lines.
- Do not use the pulse generator's power supply for anything other than the pulse generator (encoder). Using it for another purpose can cause malfunctions due to noise.
- The length of the pulse generator's wiring must not be more than 100 meters.
- The direction of rotation of the PG can be set in user constant F1-05. The factory preset is for forward rotation, A-phase advancement.

Fig 2.25 PG-B2 Wiring

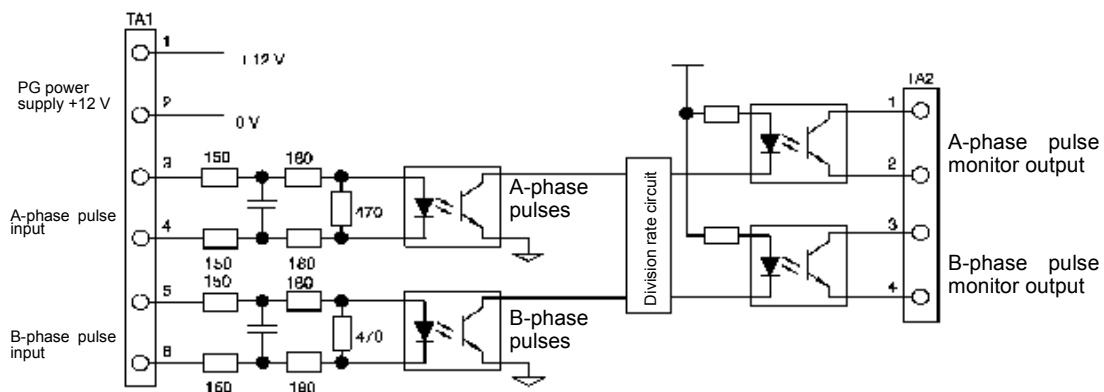

- When connecting to a voltage-output-type PG (encoder), select a PG that has an output impedance with a current of at least 12 mA to the input circuit photocoupler (diode).
- The pulse monitor dividing ratio can be changed using constant F1-06.

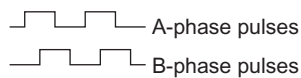
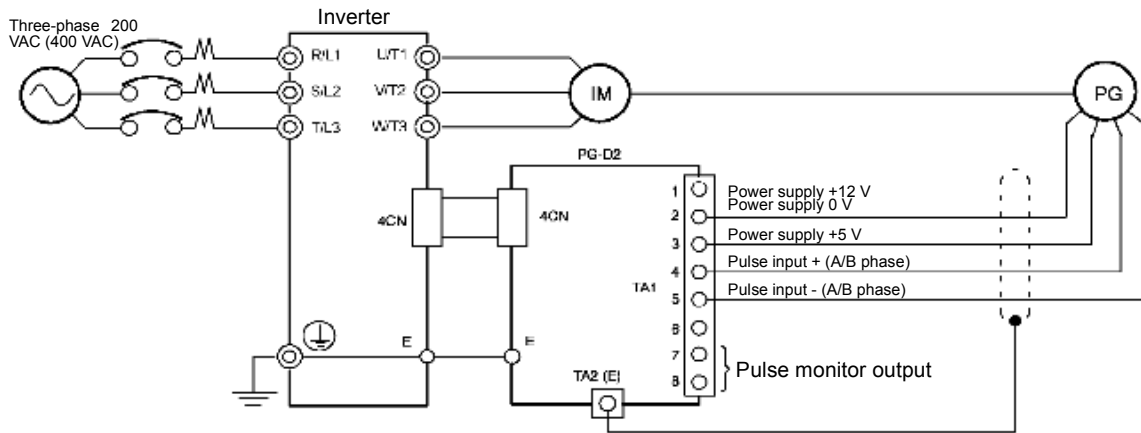

Fig 2.26 I/O Circuit Configuration of the PG-B2

■Wiring the PG-D2

Wiring examples are provided in the following illustrations for the PG-D2.



- Shielded twisted-pair wires must be used for signal lines.
- Do not use the pulse generator's power supply for anything other than the pulse generator (encoder). Using it for another purpose can cause malfunctions due to noise.
- The length of the pulse generator's wiring must not be more than 100 meters.

Fig 2.27 PG-D2 Wiring

■Wiring the PG-X2

Wiring examples are provided in the following illustrations for the PG-X2.

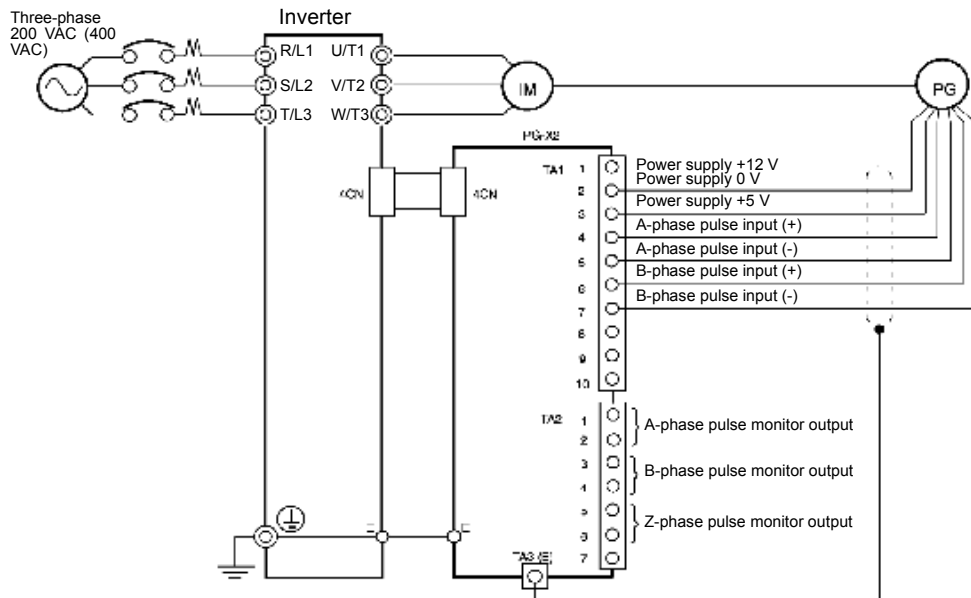

- Shielded twisted-pair wires must be used for signal lines.
- Do not use the pulse generator's power supply for anything other than the pulse generator (encoder). Using it for another purpose can cause malfunctions due to noise.
- The length of the pulse generator's wiring must not be more than 100 meters.
- The direction of rotation of the PG can be set in user constant F1-05 (PG Rotation). The factory preset is for motor forward rotation, A-phase advancement.

Fig 2.28 PG-X2 Wiring

◆ Wiring Terminal Blocks

Use no more than 100 meters of wiring for PG (encoder) signal lines, and keep them separate from power lines.

Use shielded, twisted-pair wires for pulse inputs and pulse output monitor wires, and connect the shield to the shield connection terminal.

■ Wire Sizes (Same for All Models)

Terminal wire sizes are shown in *Table 2.19*.

Table 2.19 Wire Sizes

Terminal	Terminal Screws	Wire Thickness (mm ²)	Wire Type
Pulse generator power supply Pulse input terminal Pulse monitor output terminal	-	Stranded wire: 0.5 to 1.25 Single wire: 0.5 to 1.25	<ul style="list-style-type: none"> Shielded, twisted-pair wire Shielded, polyethylene-covered, vinyl sheath cable (KPEV-S by Hitachi Electric Wire or equivalent)
Shield connection terminal	M3.5	0.5 to 2	

■ Straight Solderless Terminals for Control Circuit Terminals

We recommend using straight solderless terminal on signal lines to simplify wiring and improve reliability.

Refer to *Table 2.10 Straight Solderless Terminal Sizes* for specifications.

■ Closed-loop Connector Sizes and Tightening Torque

The closed-loop connectors and tightening torques for various wire sizes are shown in *Table 2.20*.

Table 2.20 Closed-loop Connectors and Tightening Torques

Wire Thickness [mm ²]	Terminal Screws	Crimp Terminal Size	Tightening Torque (N • m)
0.5	M3.5	1.25 - 3.5	0.8
0.75		1.25 - 3.5	
1.25		1.25 - 3.5	
2		2 - 3.5	

■ Wiring Method and Precautions

The wiring method is the same as the one used for straight solderless terminals. Refer to page 2-2-21. Observe the following precautions when wiring.

- Separate the control signal lines for the PG Speed Control Card from main circuit lines and power lines.
- Connect the shield when connecting to a PG. The shield must be connected to prevent operational errors caused by noise. Also, do not use any lines that are more than 100 m long. Refer to *Fig 2.20* for details on connecting the shield.
- Connect the shield to the shield terminal (E).
- Do not solder the ends of wires. Doing so may cause contact faults.
- When not using straight solderless terminals, strip the wires to a length of approximately 5.5 mm.

◆ Selecting the Number of PG (Encoder) Pulses

The setting for the number of PG pulses depends on the model of PG Speed Control Card being used. Set the correct number for your model.

■ PG-A2/PG-B2

The maximum response frequency is 32,767 Hz.

Use a PG that outputs a maximum frequency of approximately 20 kHz for the rotational speed of the motor.

$$\frac{\text{Motor speed at maximum frequency output (min}^{-1}\text{)}}{60} \times \text{PG rating (p/rev)} = 20,000 \text{ Hz}$$

Some examples of PG output frequency (number of pulses) for the maximum frequency output are shown in *Table 2.21*.

Table 2.21 PG Pulse Selection Examples

Motor's Maximum Speed (min ⁻¹)	PG Rating (p/rev)	PG Output Frequency for Maximum Frequency Output (Hz)
1800	600	18,000
1500	800	20,000
1200	1000	20,000
900	1200	18,000

- Note 1. The motor speed at maximum frequency output is expressed as the sync rotation speed.
 2. The PG power supply is 12 V.
 3. A separate power supply is required if the PG power supply capacity is greater than 200 mA. (If momentary power loss must be handled, use a backup capacitor or other method.)

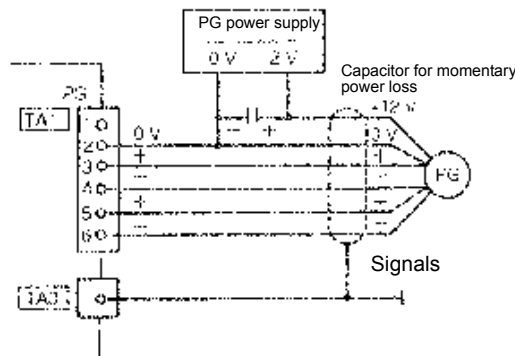

Fig 2.29 PG-B2 Connection Example

■ PG-D2/PG-X2

There are 5 V and 12 V PG power supplies.

Check the PG power supply specifications before connecting.

The maximum response frequency is 300 kHz.

Use the following equation to computer the output frequency of the PG (f_{PG}).

$$f_{PG} \text{ (Hz)} = \frac{\text{Motor speed at maximum frequency output (min}^{-1}\text{)}}{60} \times \text{PG rating (p/rev)}$$

A separate power supply is required if the PG power supply capacity is greater than 200 mA. (If momentary power loss must be handled, use a backup capacitor or other method.)

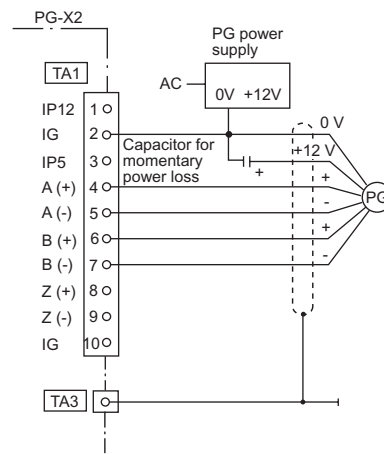

Fig 2.30 PG-X2 Connection Example (for 12 V PG power supply)



3

Digital Operator and Modes

This chapter describes Digital Operator displays and functions, and provides an overview of operating modes and switching between modes.

Digital Operator.....	3-2
Modes	3-4

Digital Operator

This section describes the displays and functions of the Digital Operator.

◆ Digital Operator Display

The key names and functions of the Digital Operator are described below.

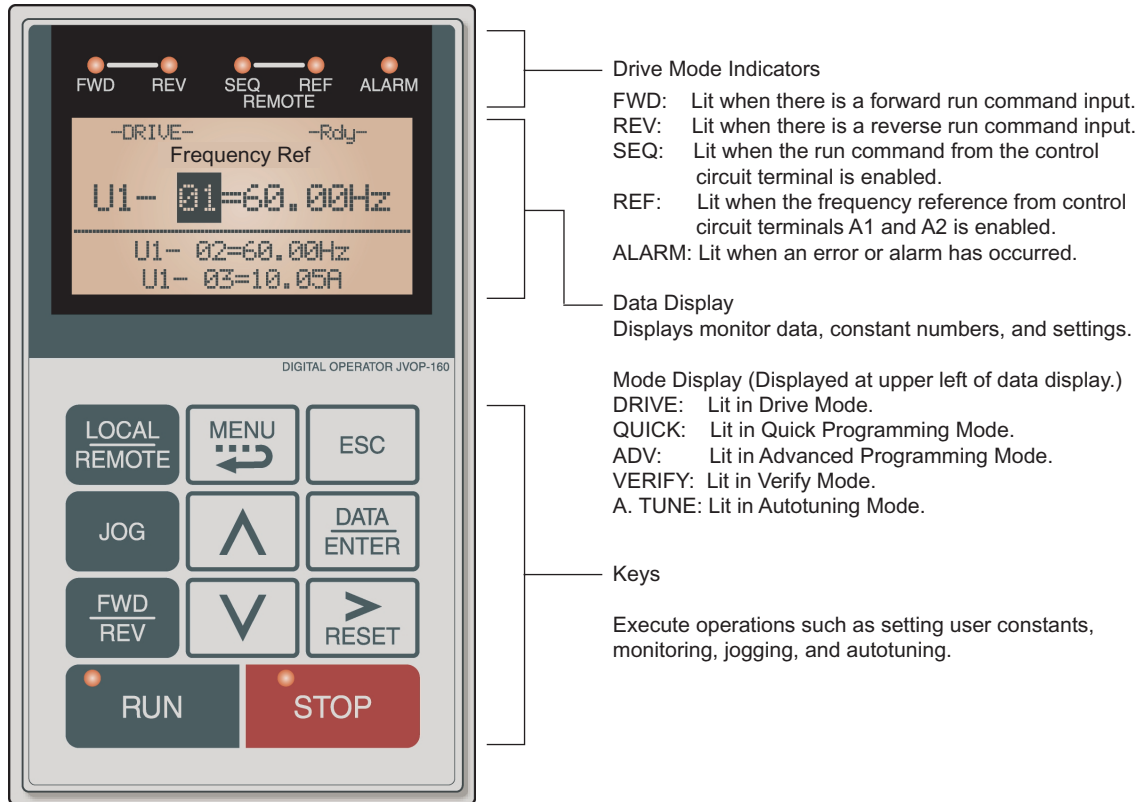

Fig 3.1 Digital Operator Component Names and Functions







◆ Digital Operator Keys

The names and functions of the Digital Operator Keys are described in *Table 3.1*.

Table 3.1 Key Functions

Key	Name	Function
	LOCAL/REMOTE Key	Switches between operation via the Digital Operator (LOCAL) and control circuit terminal operation (REMOTE). This Key can be enabled or disabled by setting user constant o2-01.
	MENU Key	Selects menu items (modes).
	ESC Key	Returns to the status before the DATA/ENTER Key was pressed.
	JOG Key	Enables jog operation when the Inverter is being operated from the Digital Operator.

Table 3.1 Key Functions (Continued)

Key	Name	Function
	FWD/REV Key	Selects the rotation direction of the motor when the Inverter is being operated from the Digital Operator.
	Shift/RESET Key	Sets the number of digits for user constant settings. Also acts as the Reset Key when a fault has occurred.
	Increment Key	Selects menu items, sets user constant numbers, and increments set values. Used to move to the next item or data.
	Decrement Key	Selects menu items, sets user constant numbers, and decrements set values. Used to move to the previous item or data.
	DATA/ENTER Key	Pressed to enter menu items, user constants, and set values. Also used to switch from one display to another.
	RUN Key	Starts the Inverter operation when the Inverter is being controlled by the Digital Operator.
	STOP Key	Stops Inverter operation. This Key can be enabled or disabled when operating from the control circuit terminal by setting user constant o2-02.

Note Except in diagrams, Keys are referred to using the Key names listed in the above table.

There are indicators on the upper left of the RUN and STOP Keys on the Digital Operator. These indicators will light and flash to indicate operating status.

The RUN Key indicator will flash and the STOP Key indicator will light during initial excitation of the dynamic brake. The relationship between the indicators on the RUN and STOP Keys and the Inverter status is shown in the Fig 3.2.

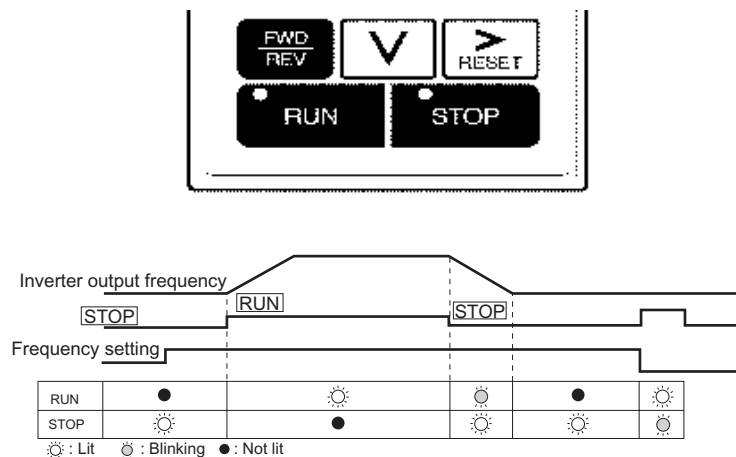

Fig 3.2 RUN and STOP Indicators

Modes

This section describes the Inverter's modes and switching between modes.

◆ Inverter Modes

The Inverter's user constants and monitoring functions are organized in groups called modes that make it easier to read and set user constants. The Inverter is equipped with 5 modes.

The 5 modes and their primary functions are shown in the *Table 3.2*.

Table 3.2 Modes

Mode	Primary function(s)
Drive mode	The Inverter can be run in this mode. Use this mode when monitoring values such as frequency references or output current, displaying fault information, or displaying the fault history.
Quick programming mode	Use this mode to reference and set the minimum user constants to operate the Inverter (e.g., the operating environment of the Inverter and Digital Operator).
Advanced programming mode	Use this mode to reference and set all user constants.
Verify mode	Use this mode to read/set user constants that have been changed from their factory-set values.
Autotuning mode*	Use this mode when running a motor with unknown motor constants in the vector control mode. The motor constants are calculated and set automatically. This mode can also be used to measure only the motor line-to-line resistance.

* Always perform autotuning with the motor before operating using vector control. Autotuning mode will not be displayed during operation or when an error has occurred. The default setting of the Inverter is for open-loop vector control 1 (A1-02 = 2).

◆ Switching Modes

The mode selection display will appear when the MENU Key is pressed from a monitor or setting display. Press the MENU Key from the mode selection display to switch between the modes.

Press the DATA/ENTER Key from the mode selection key to monitor data and from a monitor display to access the setting display.

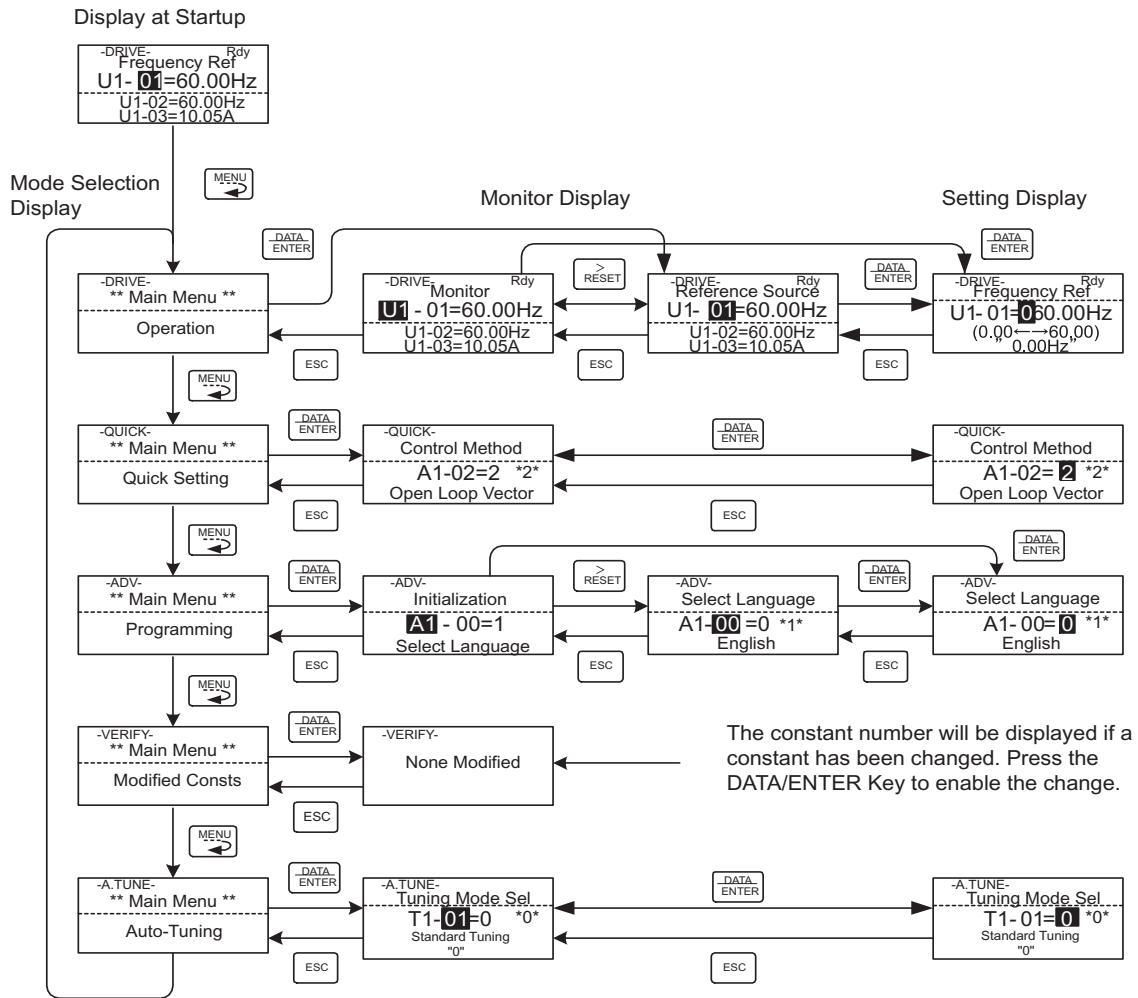

Fig 3.3 Mode Transitions



IMPORTANT

When running the Inverter after using Digital Operator, press the MENU Key to select the drive mode (displayed on the LCD screen) and then press the DATA/ENTER Key from the drive mode display to bring up the monitor display. Run commands can't be received from any other display. (Monitor display in the drive mode will appear when the power is turned ON.)

◆ Drive Mode

Drive mode is the mode in which the Inverter can be operated. The following monitor displays are possible in drive mode: The frequency reference, output frequency, output current, and output voltage, as well as fault information and the fault history.

When b1-01 (Reference selection) is set to 0, the frequency can be changed from the frequency setting display. Use the Increment, Decrement, and Shift/RESET Keys to change the frequency. The user constant will be written and the monitor display will be returned to when the DATA/ENTER Key is pressed after changing the setting.

■ Example Operations

Key operations in drive mode are shown in the following figure.

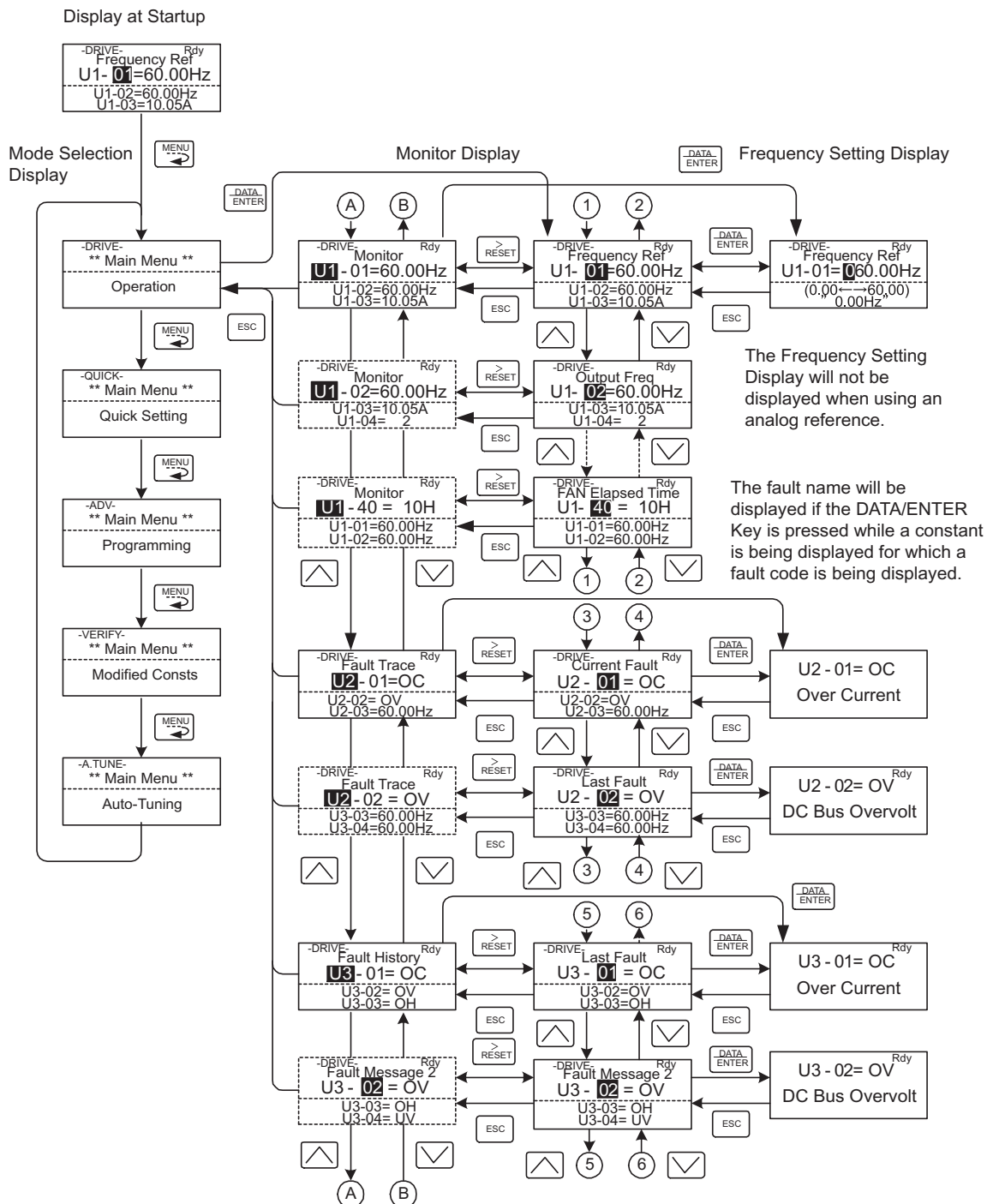

Fig 3.4 Operations in Drive Mode

Note When changing the display with the Increment and Decrement Keys, the next display after the one for the last parameter number will be the one for the first parameter number and vice versa. For example, the next display after the one for U1-01 will be U1-40. This is indicated in the figures by the letters A and B and the numbers 1 to 6.



The display for the first monitor constant (frequency reference) will be displayed when power is turned ON. The monitor item displayed at startup can be set in o1-02 (Monitor Selection after Power Up). Operation cannot be started from the mode selection display.

◆ Quick Programming Mode

In quick programming mode, the constants required for Inverter trial operation can be monitored and set.

Constants can be changed from the setting displays. Use the Increment, Decrement, and Shift/RESET Keys to change the frequency. The user constant will be written and the monitor display will be returned to when the DATA/ENTER Key is pressed after changing the setting.

Refer to *Chapter 5 User Constants* for details on the constants displayed in quick programming mode.

■ Example Operations

Key operations in quick programming mode are shown in the following figure.

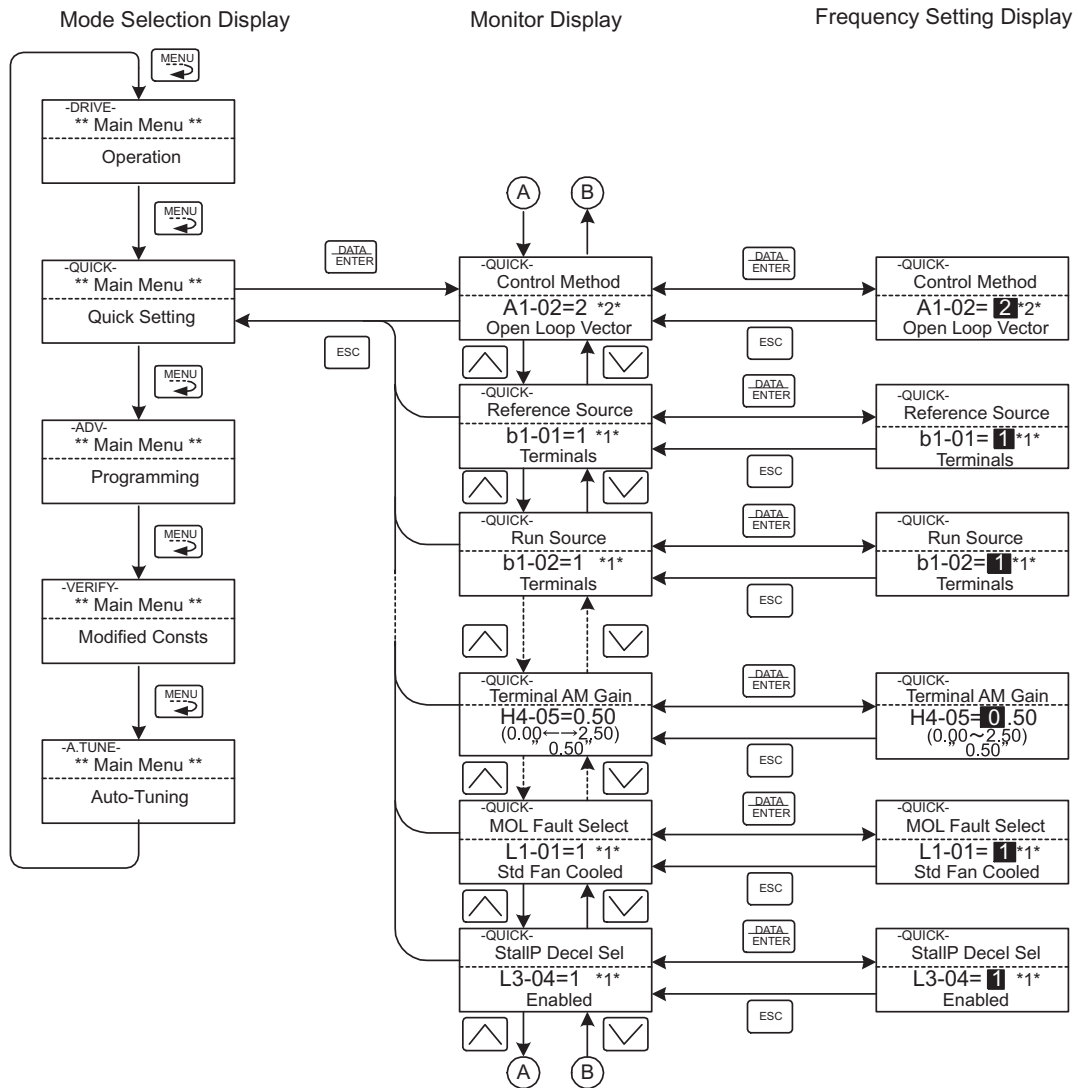

Fig 3.5 Operations in Quick Programming Mode

◆ Advanced Programming Mode

In advanced programming mode, all Inverter constants can be monitored and set.

Constants can be changed from the setting displays. Use the Increment, Decrement, and Shift/RESET Keys to change the frequency. The user constant will be written and the monitor display will be returned to when the DATA/ENTER Key is pressed after changing the setting.

Refer to *Chapter 5 User Constants* for details on the constants.

■ Example Operations

Key operations in advanced programming mode are shown in the following figure.

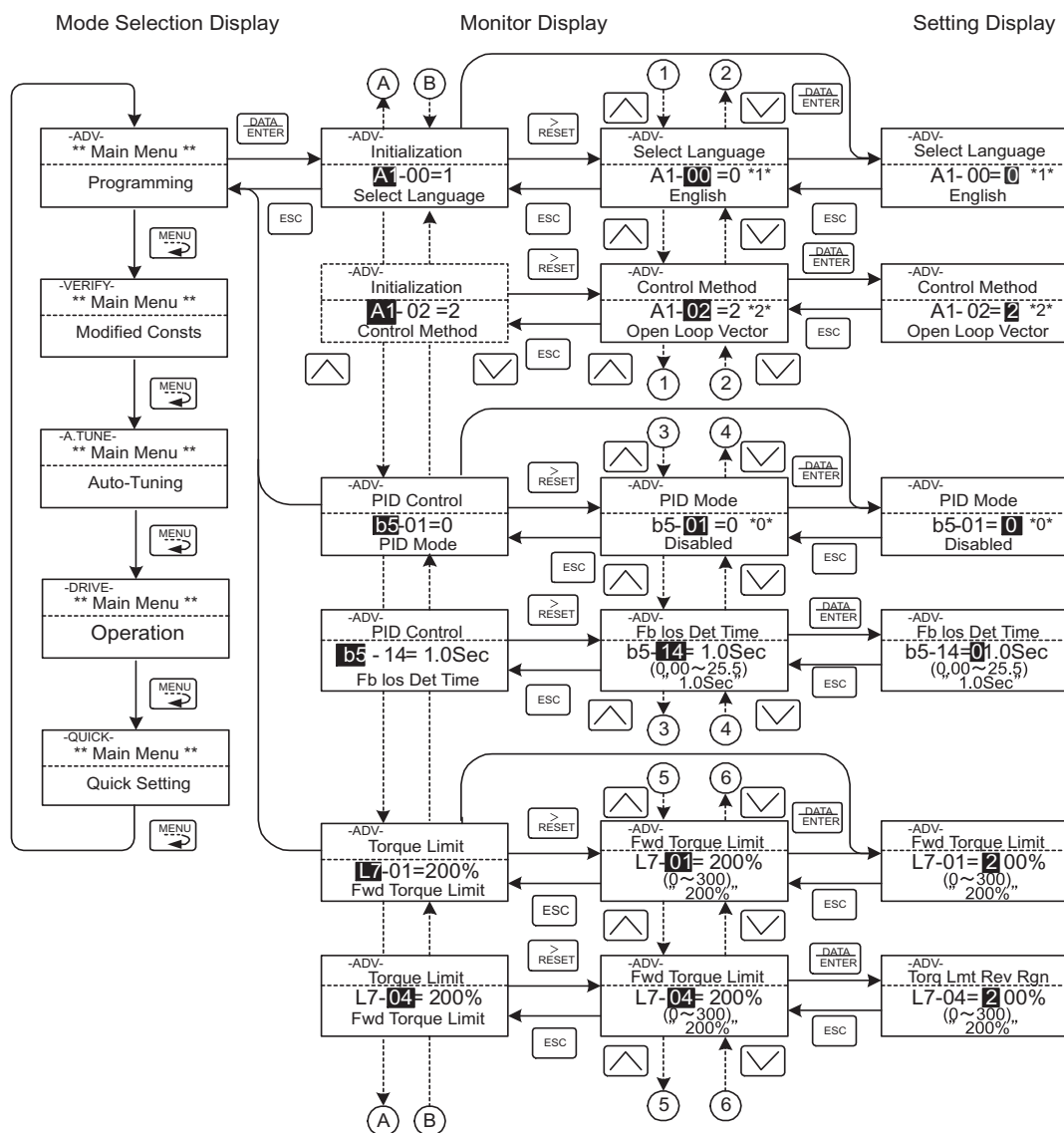

Fig 3.6 Operations in Advanced Programming Mode

■ Setting User Constants

Here, the procedure is shown to change C1-01 (Acceleration Time 1) from 10 s to 20 s.

Table 3.3 Setting User Constants in Advanced Programming Mode

Step No.	Digital Operator Display	Description
1	<pre> -DRIVE- Rdy Frequency Ref U1- 01 =60.00Hz ----- U1-02=60.00Hz U1-03=10.05A </pre>	Power supply turned ON.
2	<pre> -DRIVE- ** Main Menu ** ----- Operation </pre>	MENU Key pressed to enter drive mode.
3	<pre> -QUICK- ** Main Menu ** ----- Quick Setting </pre>	MENU Key pressed to enter quick programming mode.
4	<pre> -ADV- ** Main Menu ** ----- Programming </pre>	MENU Key pressed to enter advanced programming mode.
5	<pre> -ADV- Initialization A -00=1 ----- Select Language </pre>	DATA/ENTER pressed to access monitor display.
6	<pre> -ADV- Accel Time 1 C1-00= 10.0Sec (0.0-->6000.0) " 10.0Sec" </pre>	Increment or Decrement Key pressed to display C1-01 (Acceleration Time 1).
7	<pre> -ADV- Accel Time 1 C1-01= 0 010.0Sec (0.0-->6000.0) " 10.0Sec" </pre>	DATA/ENTER Key pressed to access setting display. The setting of C1-01 (10.00) is displayed.
8	<pre> -ADV- Accel Time 1 C1-01= 0 010.0Sec (0.0-->6000.0) " 10.0Sec" </pre>	Shift/RESET Key pressed to move the flashing digit to the right.
9	<pre> -ADV- Accel Time 1 C1-01= 00 10.0Sec (0.0-->6000.0) " 10.0Sec" </pre>	Increment Key pressed to change set value to 20.00 s.
10	<pre> -ADV- Accel Time 1 C1-01= 00 20.0Sec (0.0-->6000.0) " 10.0Sec" </pre>	DATA/ENTER Key pressed to enter the set data.
11	<pre> -ADV- Entry Accepted </pre>	“Entry Accepted” is displayed for 1.0 s after the data setting has been confirmed with the DATA/ENTER Key.
12	<pre> -ADV- Accel Time 1 C1-01= 20.0Sec (0.0-->6000.0) " 10.0Sec" </pre>	The monitor display for C1-01 returns.

External Fault Setting Procedure

Examples of the Digital Operator displays that appear when setting an eternal error for a multi-function contact input in Advanced Programming Mode are shown in the following diagram.

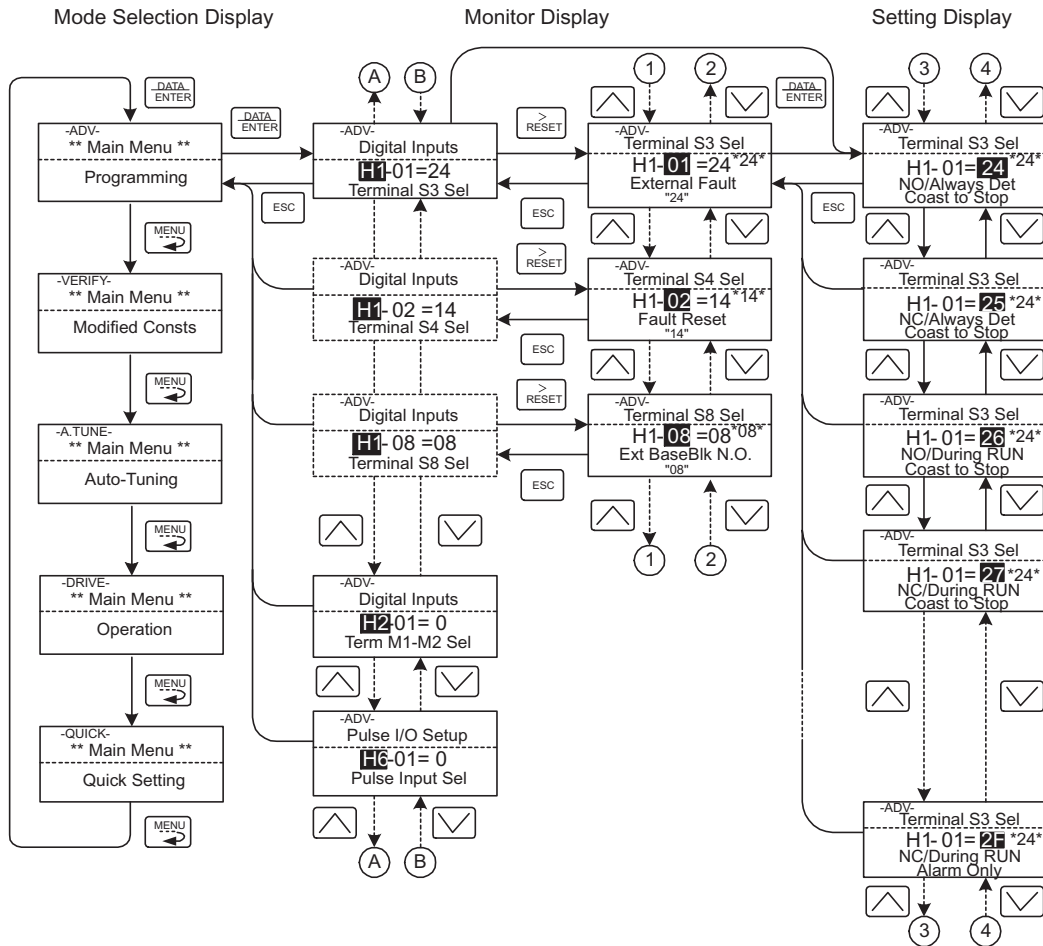

Fig 3.7 External Fault Function Setting Example

◆ Verify Mode

Verify mode is used to display any constants that have been changed from their default settings in a programming mode or by autotuning. “None” will be displayed if no settings have been changed.

Of the environment mode settings, only A1-02 will be displayed if it has been changed. Other environment modes settings will not be displayed even if they have been changed from their default settings.

Even in verify mode, the same procedures can be used to change settings as are used in the programming modes. Use the Increment, Decrement, and Shift/RESET Keys to change the frequency. The user constant will be written and the monitor display will be returned to when the DATA/ENTER Key is pressed after changing the setting.

■ Example Operations

An example of key operations is given below for when the following settings have been changed from their default settings: b1-01 (Reference Selection), C1-01 (Acceleration Time 1), E1-01 (Input Voltage Setting), and E2-01 (Motor Rated Current).

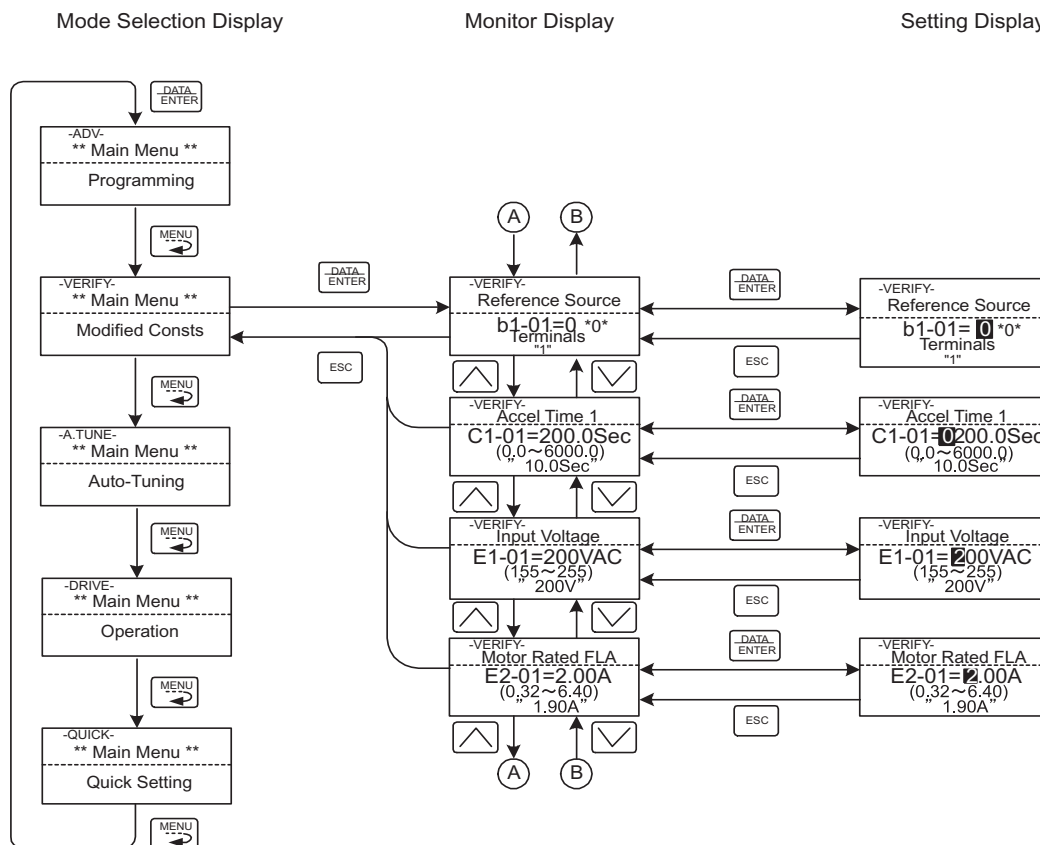

Fig 3.8 Operations in Verify Mode

◆ Autotuning Mode

Autotuning automatically tunes and sets the required motor constants when operating in the vector control modes. Always perform autotuning before starting operation.

When V/f control has been selected, stationary autotuning for only line-to-line resistance can be selected.

When the motor cannot be disconnected from the load, perform stationary autotuning. Contact your Yaskawa representatives to set motor constants by calculation.

The Inverter's autotuning function automatically determines the motor constants, while a servo system's autotuning function determines the size of a load, so these autotuning functions are fundamentally different. The default setting of the Inverter is for open-loop vector control 1.

■ Example of Operation

Set the motor output power (in kW), rated voltage, rated current, rated frequency, rated speed, and number of poles specified on the nameplate on the motor and then press the RUN Key. The motor is automatically run and the motor constants measured based on these settings and autotuning will be set.

Always set the above items. Autotuning cannot be started otherwise, e.g., it cannot be started from the motor rated voltage display.

Constants can be changed from the setting displays. Use the Increment, Decrement, and Shift/RESET Keys to change the frequency. The user constant will be written and the monitor display will be returned to when the DATA/ENTER Key is pressed after changing the setting.

The following example shows autotuning for open-loop vector control while operating the motor without switching to motor 2.

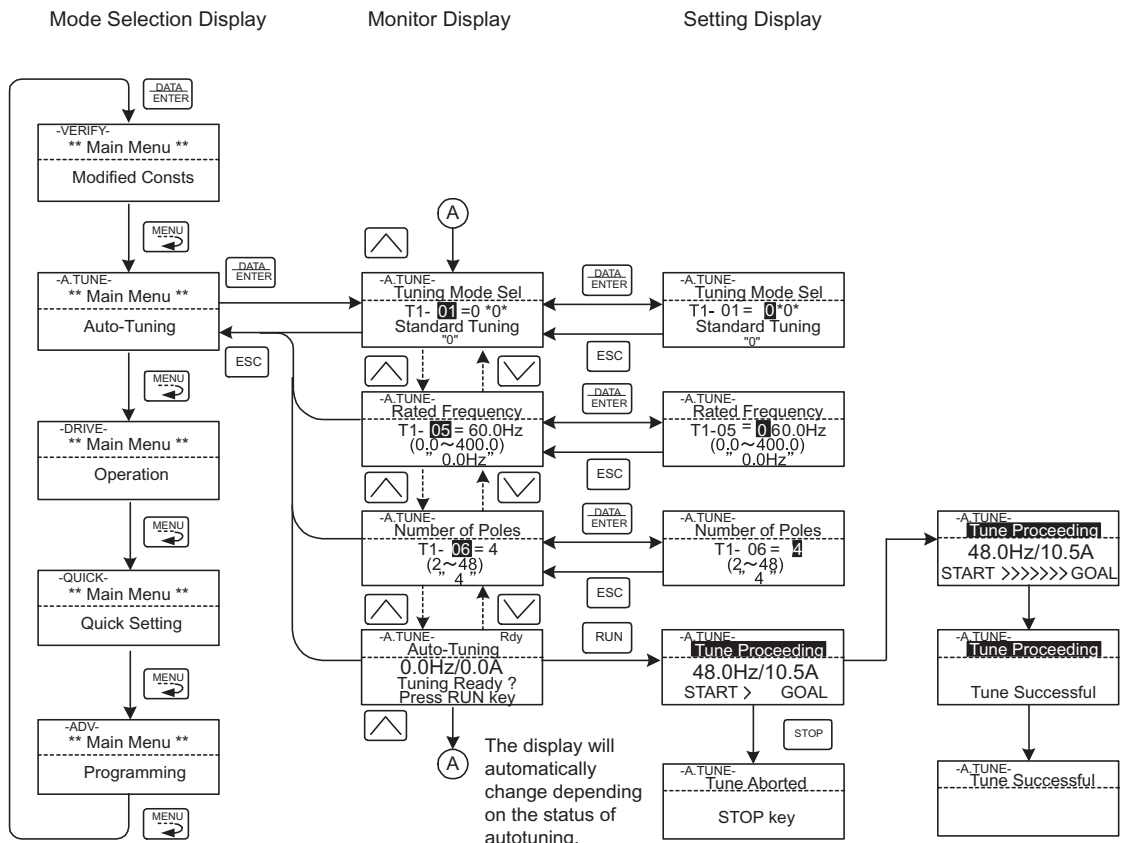

* TUn10 will be displayed during rotational autotuning and TUn11 will be displayed during stationary autotuning. The DRIVE indicator will light when autotuning starts.

Fig 3.9 Operation in Autotuning Mode



The setting displays in for autotuning depend on the control mode (V/f, V/f with PG, open-loop vector 1, open-loop vector 2, or flux vector). If a fault occurs during autotuning, refer to *Chapter 7 Troubleshooting*.

IMPORTANT



4

Trial Operation

This chapter describes the procedures for trial operation of the Inverter and provides an example of trial operation.

Trial Operation Procedure.....	4-2
Trial Operation Procedures.....	4-3
Adjustment Suggestions	4-16

Trial Operation Procedure

Perform trial operation according to the following flowchart.

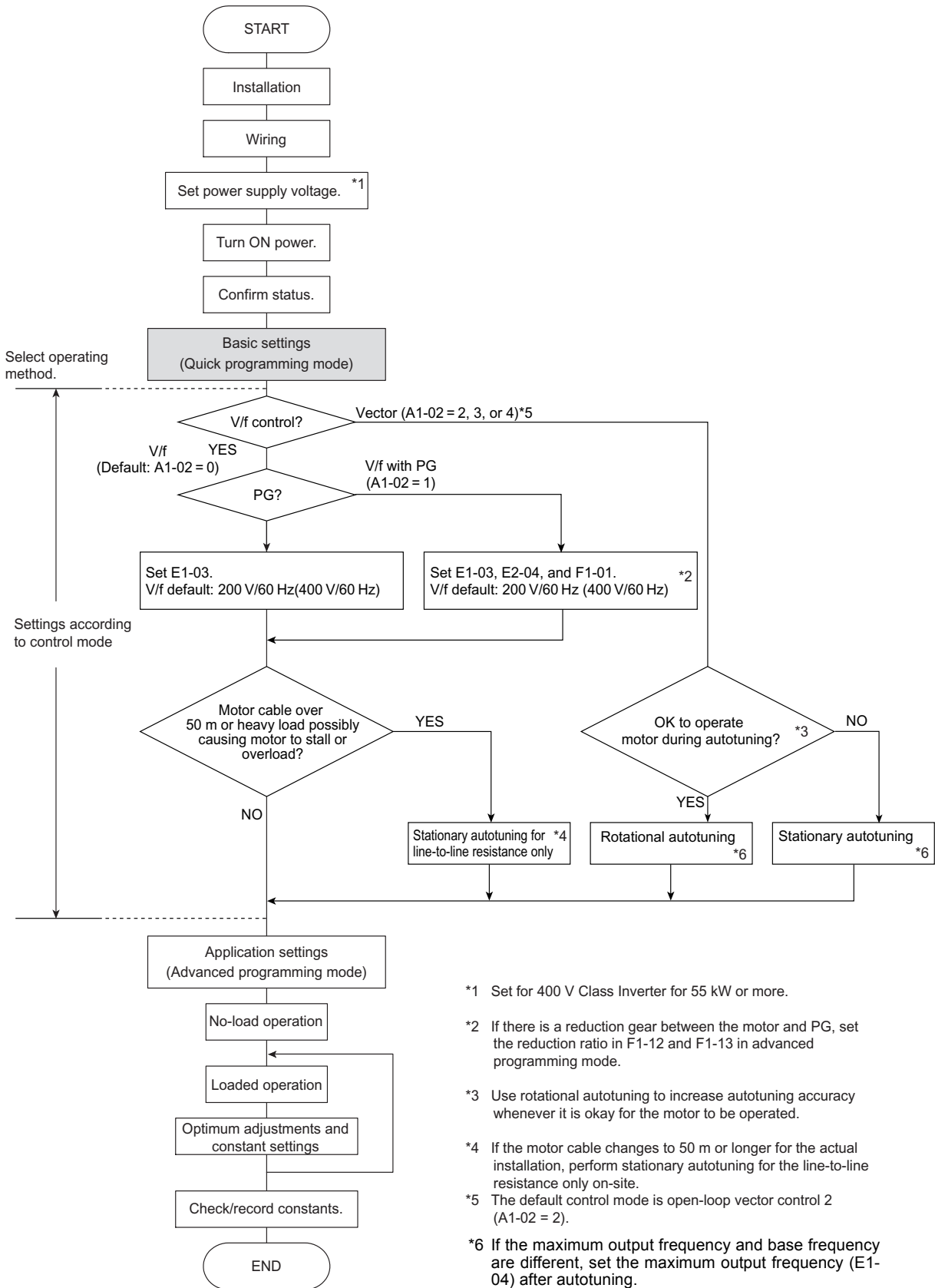

Fig 4.1 Trial Operation Flowchart

Trial Operation Procedures

The procedure for the trial operate is described in order in this section.

◆ Setting the Power Supply Voltage Jumper (400 V Class Inverters of 55 kW or Higher)

Set the power supply voltage jumper after setting E1-01 (Input Voltage Setting) for 400 V Class Inverters of 55 kW or higher. Insert the jumper into the voltage connector nearest to the actual power supply voltage.

The jumper is factory-set to 440 V when shipped. If the power supply voltage is not 440 V, use the following procedure to change the setting.

1. Turn OFF the power supply and wait for at least 5 minutes.
2. Confirm that the CHARGE indicator has gone out.
3. Remove the terminal cover.
4. Insert the jumper at the position for the voltage supplied to the Inverter (see *Fig 4.2*).
5. Return the terminal cover to its original position.

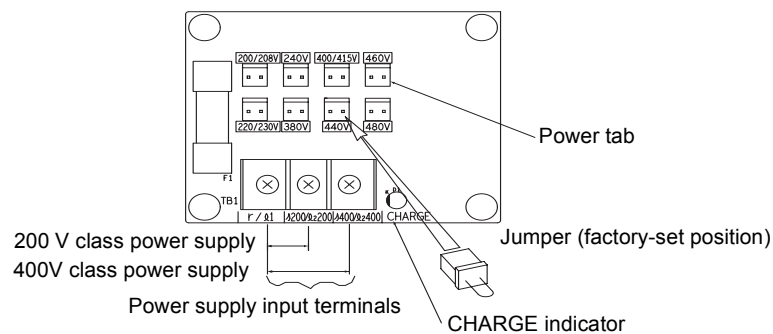

Fig 4.2 Power Supply Voltage Jumper

◆ Power ON

Confirm all of the following items and then turn ON the power supply.

- Check that the power supply is of the correct voltage.
 - 200 V class: 3-phase 200 to 240 VDC, 50/60 Hz
 - 400 V class: 3-phase 380 to 480 VDC, 50/60 Hz
- Make sure that the motor output terminals (U, V, W) and the motor are connected correctly.
- Make sure that the Inverter control circuit terminal and the control device are wired correctly.
- Set all Inverter control circuit terminals to OFF.
- When using a PG Speed Control Card, make sure that it is wired correctly.
- Make sure that the motor is not connected to the mechanical system (no-load status)

◆ Checking the Display Status

If the Digital Operator's display at the time the power is connected is normal, it will read as follows:

Display for normal operation

-DRIVE-	Rdy
Frequency Ref	
U1-01= 60.0 0Hz	

U1-02=60.00Hz	
U1-03=10.05A	

The frequency reference monitor is displayed in the data display section.

When an fault has occurred, the details of the fault will be displayed instead of the above display. In that case, refer to *Chapter 7 Troubleshooting*. The following display is an example of a display for faulty operation.

Display for fault operation

-DRIVE-
UV
DC Bus Undervolt

The display will differ depending on the type of fault.
A low voltage alarm is shown at left.

◆ Basic Settings

Switch to the quick programming mode (“QUICK” will be displayed on the LCD screen) and then set the following user constants. Refer to *Chapter 3 Digital Operator and Modes* for Digital Operator operating procedures and to *Chapter 5 User Constants* and *Chapter 6 Constant Settings by Function* for details on the user constants.

Constants that must be set are listed in *Table 4.1* and those that are set according to the application are listed in *Table 4.2*.

Table 4.1 Constants that Must Be Set

Constant Number	Name	Description	Setting Range	Factory Setting	Page
A1-02	Control method selection	Set the control method for the Inverter. 0: V/f control 1: V/f control with PG 2: Open-loop vector control 1 3: Flux vector 4: Open-loop vector control 2	0 to 4	2	5-8
b1-01	Reference selection	Set the frequency reference input method. 0: Digital Operator 1: Control circuit terminal (analog input) 2: MEMOBUS communications 3: Option Card 4: Pulse train input	0 to 4	1	5-10 6-6 6-60 6-75
b1-02	Operation method selection	Set the run command input method. 0: Digital Operator 1: Control circuit terminal (sequence input) 2: MEMOBUS communications 3: Option Card	0 to 3	1	5-10 6-11 6-60 6-75
C1-01	Acceleration time 1	Set the acceleration time in seconds for the output frequency to climb from 0% to 100%.	0.0 to 6000.0	10.0 s	5-18 6-18
C1-02	Deceleration time 1	Set the deceleration time in seconds for the output frequency to fall from 100% to 0%.	0.0 to 6000.0	10.0 s	5-18 6-18
E1-01	Input voltage setting	Set the Inverter's nominal input voltage in volts.	155 to 255 V (200 V class) 310 to 510 V (400 V class)	200 V (200 V class) 400 V (400 V class)	5-28 6-99
E2-01	Motor rated current	Set the motor rated current.	10% to 200% of Inverter's rated current	Setting for general-purpose motor of same capacity as Inverter	5-30 6-45 6-97
L1-01	Motor protection selection	Set to enable or disable the motor overload protection function using the electronic thermal relay. 0: Disabled 1: General motor protection 2: Inverter motor protection 3: Vector motor protection	0 to 3	1	5-48 6-45

Table 4.2 Constants that Are Set as Required

Constant Number	Name	Description	Setting Range	Factory Setting	Page
b1-03	Stopping method selection	Select stopping method when stop command is sent. 0: Deceleration to stop 1: Coast to stop 2: DC braking stop 3: Coast to stop with timer	0 to 3	0	5-10 6-13
C6-02	Carrier frequency selection	The carrier frequency is set low if the motor cable is 50 m or longer or to reduce radio noise or leakage current.	1 to F	Depends on capacity, voltage, and control mode.	5-23
C6-11	Carrier frequency selection for open-loop vector control 2		1 to 4	Depends on kVA setting.	5-25
d1-01 to d1-04 and d1-17	Frequency references 1 to 4 and jog frequency reference	Set the required speed references for multi-step speed operation or jogging.	0 to 400.00 Hz	d1-01 to d1-04: 0.00 Hz d1-17: 6.00 Hz	5-24 6-9
H4-02 and H4-05	FM and AM terminal output gain	Adjust when an instrument is connected to the FM or AM terminal.	0.00 to 2.50	H4-02: 1.00 H4-05: 0.50	5-45
L3-04	Stall prevention selection during deceleration	If using the dynamic brake option (braking resistor, Braking Resistor Units, and Braking Units), be sure to set constant L3-04 to 0 (disabled) or 3 (enabled with braking resistor).	0 to 3	1	5-52 6-23

◆ Settings for the Control Methods

Autotuning methods depend on the control method set for the Inverter. Make the settings required by the control method.

■ Overview of Settings

Make the required settings in quick programming mode and autotuning mode according to the following flow-chart.

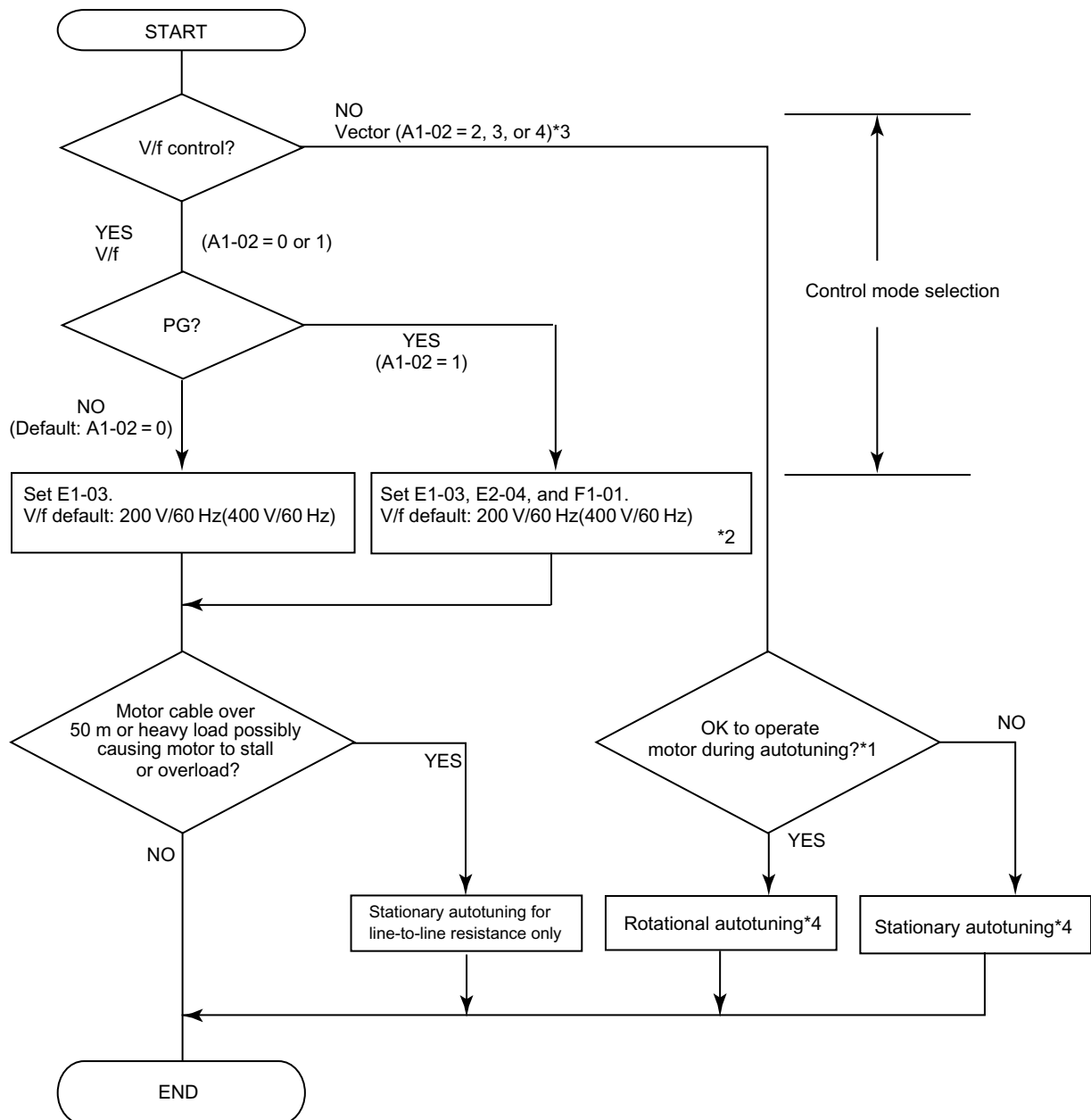

Note If the motor cable changes to 50 m or longer for the actual installation, perform stationary autotuning for the line-to-line resistance only on-site.

* 1. Use rotational autotuning to increase autotuning accuracy whenever it is okay for the motor to be operated. Always perform rotational autotuning when using open-loop vector control 2.

* 2. If there is a reduction gear between the motor and PG, set the reduction ratio in F1-12 and F1-13.

* 3. The default setting of the Inverter is for open-loop vector control 1 (A1-02 = 2).

* 4. If the maximum output frequency and base frequency are different, set the maximum output frequency (E1-04) after autotuning.

Fig 4.3 Settings According to the Control Method

■ Setting the Control Method

Any of the following five control methods can be set.

Control Mode	Constant Setting	Basic Control	Main Applications
V/f control	A1-02 = 0	Voltage/frequency ratio fixed control	Variable speed control, particularly control of multiple motors with one Inverter and replacing existing inverters
V/f control with PG	A1-02 = 1	Voltage/frequency ratio fixed control with speed compensation using a PG	Applications requiring high-precision speed control using a PG on the machine side
Open-loop vector control 1	A1-02 = 2 (factory setting)	Current vector control without a PG	Variable speed control, applications requiring speed and torque accuracy using vector control without a PG
Flux vector control	A1-02 = 3	Flux vector control	Very high-performance control with a PG (simple servo drives, high-precision speed control, torque control, and torque limiting)
Open-loop vector control 2	A1-02 = 4	Current vector control without a PG with an ASR (speed controller) (Always perform rotational autotuning.)	Very high-performance control without a PG (torque control without a PG, torque limiting, applications requiring a 1:200 speed control range without a PG)

Note With vector control, the motor and Inverter must be connected 1:1. The motor capacity for which stable control is possible is 50% to 100% of the capacity of the Inverter.

PG Control without PG (A1-02 = 0)

- Set either one of the fixed patterns (0 to E) in E1-03 (V/f Pattern Selection) or set F in E1-03 to specify a user-set pattern as required for the motor and load characteristics in E1-04 to E1-13 in advanced programming mode.

Simple operation of a general-purpose motor at 50 Hz: E1-03 = 0

Simple operation of a general-purpose motor at 60 Hz: E1-03 = F (default) or 1
If E1-03 = F, the default setting in the user setting from E1-04 to E1-13 are for 60 Hz

- Perform stationary autotuning for the line-to-line resistance only if the motor cable is 50 m or longer for the actual installation or the load is heavy enough to produce stalling. Refer to the following section on *Autotuning* for details on stationary autotuning.

V/f Control with PG (A1-02=1)

- Set either one of the fixed patterns (0 to E) in E1-03 (V/f Pattern Selection) or set F in E1-03 to specify a user-set pattern as required for the motor and load characteristics in E1-04 to E1-13 in advanced programming mode.

Simple operation of a general-purpose motor at 50 Hz: E1-03 = 0

Simple operation of a general-purpose motor at 60 Hz: E1-03 = F (default) or 1
If E1-03 = F, the default setting in the user setting from E1-04 to E1-13 are for 60 Hz

- Set the number of motor poles in E2-04 (Number of Motor Poles)
- Set the number of rotations per pulse in F1-01 (PG Constant). If there is a reduction gear between the motor and PG, set the reduction ratio in F1-12 and F1-13 in advanced programming mode.

- Perform stationary autotuning for the line-to-line resistance only if the motor cable is 50 m or longer for the actual installation or the load is heavy enough to produce stalling. Refer to the following section on *Autotuning* for details on stationary autotuning.

Open-loop Vector Control 1 (A1-02 = 2)

Perform autotuning. If the motor can be operated, perform rotational autotuning. If the motor cannot be operated, perform stationary autotuning. Refer to the following section on *Autotuning* for details on autotuning.

Flux Vector Control (A1-02 = 3)

Perform autotuning. If the motor can be operated, perform rotational autotuning. If the motor cannot be operated, perform stationary autotuning. Refer to the following section on *Autotuning* for details on autotuning.

Open-loop Vector Control 2 (A1-02 = 4)

Perform autotuning. Be sure to perform rotational autotuning. Refer to the following section on *Autotuning* for details on autotuning.

◆ Autotuning

Use the following procedure to perform autotuning to automatically set motor constants when using the vector control method, when the cable length is long, etc.

■ Setting the Autotuning Mode

One of the following three autotuning modes can be set.

- Rotational autotuning
- Stationary autotuning
- Stationary autotuning for line-to-line resistance only

Always confirm the precautions before autotuning before performing autotuning.

Rotational Autotuning (T1-01 = 0)

Rotational autotuning is used only for open-vector control. Set T1-01 to 0, input the data from the nameplate, and then press the RUN Key on the Digital Operator. The Inverter will stop the motor for approximately 1 minute and then set the required motor constants automatically while operating the motor for approximately 1 minute.

Stationary Autotuning (T1-01 = 1)

Stationary autotuning is used for open-vector control or flux vector control. Set T1-01 to 1, input the data from the nameplate, and then press the RUN Key on the Digital Operator. The Inverter will supply power to the stationary motor for approximately 1 minute and some of the motor constants will be set automatically. The remaining motor constants will be set automatically the first time operation is started in drive mode.

Stationary Autotuning for Line-to-Line Resistance Only (T1-01 = 2)

Stationary autotuning for line-to-line resistance only can be used in any control method. This is the only autotuning possible for V/f control and V/f control with PG modes.

Autotuning can be used to prevent control errors when the motor cable is long (50 m or longer) or the cable length has changed since installation or when the motor and Inverter have different capacities.

Set T1-01 to 2 for open-loop vector control, and then press the RUN Key on the Digital Operator. The Inverter will supply power to the stationary motor for approximately 20 seconds and the Motor Line-to-Line Resistance (E2-05) and cable resistance will be automatically measured.

■ Precautions Before Using Autotuning

Read the following precautions before using autotuning.

- Autotuning the Inverter is fundamentally different from autotuning the servo system. Inverter autotuning automatically adjusts parameters according to detected motor constants, whereas servo system autotuning adjusts parameters according to the detected size of the load.
- When speed precision or torque precision is required at high speeds (i.e., 90% of the rated speed or higher), use a motor with a rated voltage that is 20 V less than the input power supply voltage of the Inverter for 200V-class Inverters and 40 V less for 400V-class Inverters. If the rated voltage of the motor is the same as the input power supply voltage, the voltage output from the Inverter will be unstable at high speeds and sufficient performance will not be possible.
- Use stationary autotuning whenever performing autotuning for a motor that is connected to a load.
- Use rotational autotuning whenever performing autotuning for a motor that has fixed output characteristics, when high precision is required, or for a motor that is not connected to a load.
- If rotational autotuning is performed for a motor connected to a load, the motor constants will not be found accurately and the motor may exhibit abnormal operation. Never perform rotational autotuning for a motor connected to a load.
- If the wiring between the Inverter and motor changes by 50 m or more between autotuning and motor installation, perform stationary autotuning for line-to-line resistance only.
- If the motor cable is long (50 m or longer), perform stationary autotuning for line-to-line resistance only even when using V/f control.
- The status of the multi-function inputs and multi-function outputs will be as shown in the following table during autotuning. When performing autotuning with the motor connected to a load, be sure that the holding brake is not applied during autotuning, especially for conveyor systems or similar equipment.

Tuning Mode	Multi-function Inputs	Multi-function Outputs
Rotational autotuning	Do not function.	Same as during normal operation
Stationary autotuning	Do not function.	Maintain same status as when autotuning is started.
Stationary autotuning for line-to-line resistance only	Do not function.	Maintain same status as when autotuning is started.

- To cancel autotuning, always use the STOP Key on the Digital Operator.



1. Power will be supplied to the motor when stationary autotuning is performed even though the motor will not turn. Do not touch the motor until autotuning has been completed.
2. When performing stationary autotuning connected to a conveyor or other machine, ensure that the holding brake is not activated during autotuning.

■Precautions for Rotational and Stationary Autotuning

Lower the base voltage based on *Fig 4.4* to prevent saturation of the Inverter's output voltage when the rated voltage of the motor is higher than the voltage of the power supply to the Inverter. Use the following procedure to perform autotuning.

1. Input the voltage of the input power supply to T1-03 (Motor rated voltage).
2. Input the results of the following formula to T1-05 (Motor base frequency):
(Base frequency from the motor's nameplate × setting of T1-03)/(Rated voltage from motor's nameplate)
3. Perform autotuning.

After completing autotuning, set E1-04 (Max. output frequency) to the base frequency from the motor's nameplate.

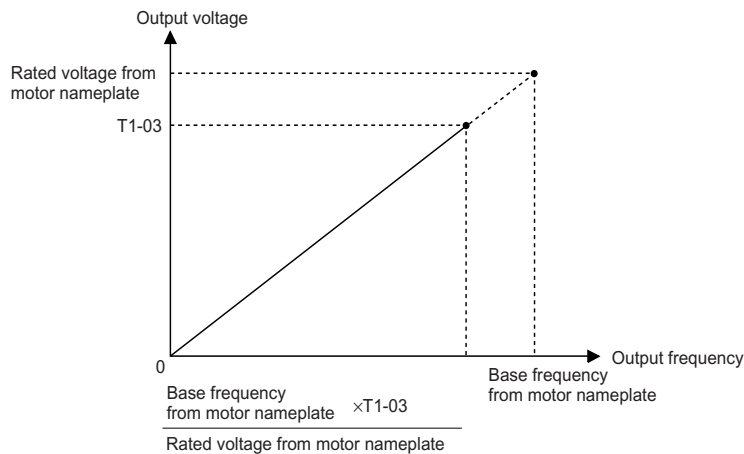

Fig 4.4 Motor Base Frequency and Inverter Input Voltage Setting



IMPORTANT

1. When speed precision is required at high speeds (i.e., 90% of the rated speed or higher), set T1-03 (Motor rated voltage) to the input power supply voltage × 0.9.
2. When operating at high speeds (i.e., 90% of the rated speed or higher), the output current will increase as the input power supply voltage is reduced. Be sure to provide sufficient margin in the Inverter current.

■Precautions after Rotational and Stationary Autotuning

If the maximum output frequency and base frequency are different, set the maximum output frequency (E1-04) after autotuning.

■ Constant Settings for Autotuning

The following constants must be set before autotuning.

Table 4.3 Constant Settings before Autotuning

Constant Number	Name	Display	Setting Range	Factory Setting	Data Displays during Autotuning				
	Display				V/f	V/f with PG	Open-loop Vector 1	Flux Vector	Open-loop Vector 2
T1-00	Motor 1/2 selection *1	When switching to motor 2 is selected, set the motor for which autotuning is to be performed. (This constant is ignored if motor 2 is not selected.) 1: Motor 1 2: Motor 2	1 or 2	1	Yes	Yes	Yes	Yes	Yes
	Select Motor								
T1-01	Autotuning mode selection	Set the autotuning mode. 0: Rotational autotuning 1: Stationary autotuning 2: Stationary autotuning for line-to-line resistance only	0 to 2	2 (V/f) 0 (Vector)*4	Yes	Yes	Yes	Yes	Yes
	Tuning Mode Sel								
T1-02	Motor output power	Set the output power of the motor in kilowatts.*5 *7	0.00 to 650.00 kW	0.40 kW *2	Yes	Yes	Yes	Yes	Yes
	Mtr Rated Power								
T1-03	Motor rated voltage	Set the rated voltage of the motor in volts.*5 *6	0 to 255.0 V (200 V class) 0 to 510.0 V (400 V class)	200.0 V (200 V class) 400.0 V (400 V class)	-	-	Yes	Yes	Yes
	Rated Voltage								
T1-04	Motor rated current	Set the rated current of the motor in amps.*5 *7	0.32 to 6.40 A *3	1.90 A *2	Yes	Yes	Yes	Yes	Yes
	Rated Current								
T1-05	Motor base frequency	Set the base frequency of the motor in hertz.*3 *4 *5 *6	0 to 400.0 Hz	60.0 Hz	-	-	Yes	Yes	Yes
	Rated Frequency								
T1-06	Number of motor poles	Set the number of motor poles.	2 to 48 poles	4 poles	-	-	Yes	Yes	Yes
	Number of Poles								

Table 4.3 Constant Settings before Autotuning(Continued)

Con- stant Num- ber	Name	Display	Setting Range	Factory Setting	Data Displays during Autotuning				
	Display				V/f	V/f with PG	Open- loop Vec- tor 1	Flux Vec- tor	Open- loop Vec- tor 2
T1-07	Motor base speed	Set the base speed of the motor in min^{-1} *3 *5	0 to 24000	1750 min^{-1}	-	-	Yes	Yes	Yes
	Rated Speed								
T1-08	Number of PG pulses when turn- ing	Set the number of pulses for the PG (pulse generator or encoder). Set the number of pulses per motor revolution without a multiplication factor.	0 to 60000	600	-	Yes	-	Yes	-
	PG Pulses/ Rev								

- * 1. Not normally displayed. Displayed only when a motor switch command is set for a multi-function digital input (one of H1-01 to H1-05 set to 16).
- * 2. The factory setting depends on the Inverter capacity. Values are given for a 200 V class, 0.4 kW Inverter.
- * 3. The setting range is 10% to 200% of the Inverter capacity.
- * 4. For V/f control, the only setting that is possible is 2 (stationary autotuning for line-to-line resistance only).
- * 5. For fixed output motors, set the base speed value.
- * 6. For inverter motors or for specialized vector motors, the voltage or frequency may be lower than for general-purpose motors. Always confirm the information on the nameplate or in test reports. If the no-load values are known, input the no-load voltage in T1-03 and the no-load current in T1-05 to ensure accuracy.
- * 7. The settings that will ensure stable vector control are between 50% and 100% of the Inverter rating.

Refer to page 3-14 for Digital Operator displays during autotuning.

◆ Application Settings

User constants are set as required in advanced programming mode (“ADV” will be displayed on the LCD screen). All the constants that can be set in quick programming mode can also be displayed and set in advanced programming mode.

■ Setting Examples

The following are examples of settings for applications.

- When using an Inverter-mounted braking resistor (ERF), set L8-01 to 1 to enable ERF braking resistor overheating protection.
- To prevent the machine from being operated in reverse, set b1-04 to 1 to disable reverse operation.
- To increase the speed of a 60 Hz motor by 10%, set E1-04 to 66.0 Hz.
- To use a 0 to 10-V analog signal for a 60 Hz motor for variable-speed operation between 0 and 54 Hz (0% to 90% speed deduction), set H3-02 to 90.0%.
- To control speed between 20% and 80% to ensure smooth gear operation and limit the maximum speed of the machine, set d2-01 to 80.0% and set d2-02 to 20.0%.

◆ No-load Operation

To begin no-load operation (without connecting the machine and the motor), press the LOCAL/REMOTE Key on the Digital Operator to change to LOCAL mode (the SEQ and REF indicators on the Digital Operator should be OFF).

Always confirm safety around the motor and machine before starting Inverter operation from the Digital Operator. Confirm that the motor works normally and that no errors are displayed at the Inverter.

Jog Frequency Reference (d1-17, default: 6.00 Hz) can be started and stopped by pressing and releasing the JOG Key on the Digital Operator. If the external sequence prevent operation from the Digital Operator, confirm that emergency stop circuits and machine safety mechanisms are functioning, and then start operation in REMOTE mode (i.e., with a signal from the control signal terminals). The safety precautions must always be taken before starting the Inverter with the motor connected to the machine.



INFO

Both a RUN command (forward or reverse) and a frequency reference (or multi-step speed reference) must be provided to start Inverter operation.
Input these commands and reference regardless of the operation method (i.e., LOCAL or REMOTE).

◆ Loaded Operation

Connect the machine to the motor and then start operation as described for no-load operation (i.e., from the Digital Operator or by using control circuit terminal signals).

■ Connecting the Load

- After confirming that the motor has stopped completely, connect the mechanical system.
- Be sure to tighten all the screws when securing the motor shaft to the mechanical system.

■ Operation using the Digital Operator

- Use the Digital Operator to start operation in LOCAL mode in the same way as in no-load operation.
- If fault occurs during operation, make sure the STOP Key on the Digital Operator is easily accessible.
- At first, set the frequency reference to a low speed of one tenth the normal operating speed.

■ Checking Operating Status

- Having checked that the operating direction is correct and that the machine is operating smoothly at slow speed, increase the frequency reference.
- After changing the frequency reference or the rotation direction, check that there is no oscillation or abnormal sound from the motor. Check the monitor display to ensure that U1-03 (Output Current) is not too high.
- Refer to *Adjustment Suggestions* on page 4-16 if hunting, vibration, or other problems originating in the control system occur.

◆ Check and Recording User Constants

Use verify mode (“VERIFY” will be displayed on the LCD screen) to check user constants that have been changed for trial operation and record them in a user constant table.

Any user constants that have been change by autotuning will also be displayed in verify mode.

If required, the copy function in constants o3-01 and o3-02 displayed in advanced programming mode can be used to copy the changed settings from the Inverter to a recording area in the Digital Operator. If changed settings are saved in the Digital Operator, they can be easily copied back to the Inverter to speed up system recovery if for any reason the Inverter has to be replaced.

The following functions can also be used to manage user constants.

- Recording user constants
- Setting access levels for user constants
- Setting a password

■ Recording User Constants (o2-03)

If o2-03 is set to 1 after completing trial operation, the settings of user constants will be saved in a separate memory area in the Inverter. Later, after Inverter settings have been changed, the user constants can be initialized to the settings saved in the separate memory area when o2-03 was set to 1 by setting A1-03 (Initialize) to 1110.

■ User Constant Access Levels (A1-01)

A1-01 can be set to 0 (monitoring-only) to prevent user constants from being changed. A1-01 can also be set to 1 (User-specified Constants) and used along with A2 constants to display only constants required by the machine or application in a programming mode.

■ Password (A1-04 and A1-05)

When the access level is set to monitoring-only (A1-01 = 0), a password can be set so that user constants will be displayed only when the correct password is input.

Adjustment Suggestions

If hunting, vibration, or other problems originating in the control system occur during trial operation, adjust the constants listed in the following table according to the control method. This table lists only the most commonly used user constants.

Table 4.4 Adjusted User Constants

Control Method	Name (Constant Number)	Performance	Factory Setting	Recommended Setting	Adjustment Method
V/f control (A1-02 = 0 or 1)	Hunting-prevention gain (N1-02)	Controlling hunting and vibration in middle-range speeds (10 to 40 Hz)	1.00	0.50 to 2.00	<ul style="list-style-type: none"> Reduce the setting if torque is insufficient for heavy loads. Increase the setting if hunting or vibration occurs for light loads.
	Carrier frequency selection (C6-02)	<ul style="list-style-type: none"> Reducing motor magnetic noise Controlling hunting and vibration at low speeds 	Depends on capacity	0 to default	<ul style="list-style-type: none"> Increase the setting if motor magnetic noise is high. Reduce the setting if hunting or vibration occurs at low to middle-range speeds.
	Torque compensation primary delay time constant (C4-02)	<ul style="list-style-type: none"> Increasing torque and speed response Controlling hunting and vibration 	Depends on capacity	200 to 1000 ms	<ul style="list-style-type: none"> Reduce the setting if torque or speed response is slow. Increase the setting if hunting or vibration occurs.
	Torque compensation gain (C4-01)	<ul style="list-style-type: none"> Improving torque at low speeds (10 Hz or lower) Controlling hunting and vibration 	1.00	0.50 to 1.50	<ul style="list-style-type: none"> Increase the setting if torque is insufficient at low speeds. Reduce the setting if hunting or vibration occurs for light loads.
	Middle output frequency voltage (E1-08) Minimum output frequency voltage (E1-10)	<ul style="list-style-type: none"> Improving torque at low speeds Controlling shock at startup 	Depends on capacity and voltage	Default to Default + 3 to 5 V*	<ul style="list-style-type: none"> Increase the setting if torque is insufficient at low speeds. Reduce the setting if shock at startup is large.
Open-loop vector control (A1-02 = 2)	Speed feedback detection control (AFR) gain (N2-01)	<ul style="list-style-type: none"> Increasing torque and speed response Controlling hunting and vibration in middle-range speeds (10 to 40 Hz) 	1.00	0.50 to 2.00	<ul style="list-style-type: none"> Reduce the setting if torque or speed response is slow. Increase the setting if hunting or vibration occurs.
	Torque compensation primary delay time constant (C4-02)	<ul style="list-style-type: none"> Increasing torque and speed response Controlling hunting and vibration 	20 ms	20 to 100 ms	<ul style="list-style-type: none"> Reduce the setting if torque or speed response is slow. Increase the setting if hunting or vibration occurs.
	Slip compensation primary delay time (C3-02)	<ul style="list-style-type: none"> Increasing speed response Improving speed stability 	200 ms	100 to 500 ms	<ul style="list-style-type: none"> Reduce the setting if speed response is slow. Increase the setting if the speed is not stable.
	Slip compensation gain (C3-01)	<ul style="list-style-type: none"> Improving speed accuracy 	1.0	0.5 to 1.5	<ul style="list-style-type: none"> Increase the setting if speed response is slow. Reduce the setting if the speed is too fast.

Table 4.4 Adjusted User Constants (Continued)

Control Method	Name (Constant Number)	Performance	Factory Setting	Recommended Setting	Adjustment Method
Open-loop vector control 1 (A1-02 = 2)	Carrier frequency selection (C6-02)	<ul style="list-style-type: none"> Reducing motor magnetic noise Controlling hunting and vibration at low speeds (10 Hz or less) 	Depends on capacity	0 to default	<ul style="list-style-type: none"> Increase the setting if motor magnetic noise is high. Reduce the setting if hunting or vibration occurs at low speeds.
	Middle output frequency voltage (E1-08) Minimum output frequency voltage (E1-10)	<ul style="list-style-type: none"> Improving torque at low speeds Controlling shock at startup 	Depends on capacity and voltage	Default to Default + 1 or 2 V*	<ul style="list-style-type: none"> Increase the setting if torque or speed response is slow. Reduce the setting if shock at startup is large.
Flux vector control (A1-02 = 3)	ASR proportional gain 1 (C5-01) and ASR proportional gain 2 (C5-03)	<ul style="list-style-type: none"> Torque and speed response Controlling hunting and vibration 	20.00	10.00 to 50.00	<ul style="list-style-type: none"> Increase the setting if torque or speed response is slow. Reduce the setting if hunting or vibration occurs.
	ASR integral time 1 (high-speed) (C5-02) and ASR integral time 2 (low-speed) (C5-04)	<ul style="list-style-type: none"> Torque and speed response Controlling hunting and vibration 	0.500 s	0.300 to 1.000 s	<ul style="list-style-type: none"> Reduce the setting if torque or speed response is slow. Increase the setting if hunting or vibration occurs.
	ASR switching frequency (C5-07)	Switching the ASR proportional gain and integral time according to the output frequency	0.0 Hz	0.0 to max. output frequency	Set the output frequency at which to change the ASR proportional gain and integral time when the same values cannot be used for both high-speed and low-speed operation.
	ASR primary delay time (C5-06)	<ul style="list-style-type: none"> Controlling hunting and vibration 	0.004 s	0.004 to 0.020	Increase the setting if machine rigidity is low and the system vibrates easily.
	Carrier frequency selection (C6-02)	<ul style="list-style-type: none"> Reducing motor magnetic noise Controlling hunting and vibration at low speeds (3 Hz or less) 	Depends on the capacity.	2.0 kHz to default	<ul style="list-style-type: none"> Increase the setting if motor magnetic noise is high. Reduce the setting if hunting or vibration occurs at low to middle-range speeds.

Table 4.4 Adjusted User Constants (Continued)

Control Method	Name (Constant Number)	Performance	Factory Setting	Recommended Setting	Adjustment Method
Open-loop vector control 2 (A1-02 = 4)	ASR proportional gain 1 (C5-01) and ASR proportional gain 2 (C5-03)	<ul style="list-style-type: none"> Torque and speed response Controlling hunting and vibration 	10.00	10.00 to 50.00	<ul style="list-style-type: none"> Increase the setting if torque or speed response is slow. Reduce the setting if hunting or vibration occurs.
	ASR integral time 1 (high-speed) (C5-02) and ASR integral time 2 (low-speed) (C5-04)	<ul style="list-style-type: none"> Torque and speed response Controlling hunting and vibration 	0.500 s	0.300 to 1.000 s	<ul style="list-style-type: none"> Reduce the setting if torque or speed response is slow. Increase the setting if hunting or vibration occurs.
	ASR switching frequency (C5-07)	Switching the ASR proportional gain and integral time according to the output frequency	0.0 Hz	0.0 to max. output frequency	Set the output frequency at which to change the ASR proportional gain and integral time when the same values cannot be used for both high-speed and low-speed operation.
	ASR primary delay time (C5-06)	<ul style="list-style-type: none"> Controlling hunting and vibration 	0.010 s	0.04 to 0.020	Increase the setting if machine rigidity is low and the system vibrates easily.
	Carrier frequency selection (C6-11)	<ul style="list-style-type: none"> Reducing motor magnetic noise Controlling hunting and vibration at low speeds (3 Hz or less) 	Depends on the capacity.	Default value	<ul style="list-style-type: none"> Increase the setting if motor magnetic noise is high. Reduce the setting if hunting or vibration occurs at low to middle-range speeds.

* The setting is given for 200 V Class Inverters. Double the voltage for 400 V Class Inverters.

- Do not change the Torque Compensation Gain (C4-01) from its default setting of 1.00 when using open-loop vector control 1.
- If speeds are inaccurate during regeneration in open-loop vector control 1, enable Slip Compensation During Regeneration (C3-04 = 1).
- Use slip compensation to improve speed precision during V/f control (A1-02 = 0). Set the Motor Rated Current (E2-01), Motor Rated Slip (E2-02), and Motor No-load Current (E2-03), and then adjust the Slip Compensation Gain (C3-01) to between 0.5 and 1.5. The default setting for V/f control is C3-01 = 0.0 (slip compensation disabled).
- To improve speed response and stability in V/f control with a PG (A1-02 = 1), set the ASR constants (C5-01 to C5-05) to between 0.5 and 1.5 times the default. (It is not normally necessary to adjust this setting.) ASR for V/f control with a PG will only control the output frequency; a high gain, such as is possible for open-loop vector control 2 or flux vector control, cannot be set.

The following user constants will also indirectly affect the control system.

Table 4.5 Constants Indirectly Affecting Control and Applications

Name (Constant Number)	Application
Dwell function (b6-01 to b6-04)	Used for heavy loads or large machine backlashes.
Droop function (b7-01 to b7-02)	Used to soften the torque or to balance the load between two motors. Can be used when the control mode (A1-02) is set to 3 or 4.
Acceleration/deceleration times (C1-01 to C1-11)	Adjust torque during acceleration and deceleration.
S-curve characteristics (C2-01 to C2-04)	Used to prevent shock when completing acceleration.

Table 4.5 Constants Indirectly Affecting Control and Applications(Continued)

Name (Constant Number)	Application
Jump frequencies (d3-01 to d3-04)	Used to avoid resonance points during operation.
Analog input filter time constant (H3-12)	Used to prevent fluctuations in analog input signals caused by noise.
Stall prevention (L3-01 to L3-06)	Used to prevent 0 V (overvoltage errors) and motor stalling for heavy loads or rapid acceleration/deceleration. Stall prevention is enabled by default and the setting does not normally need to be changed. When using a braking resistor, however, disable stall prevention during deceleration by setting L3-04 to 0.
Torque limits (L7-01 to L7-04)	Set the maximum torque during vector control. If a setting is increased, use a motor with higher capacity than the Inverter. If a setting is reduced, stalling can occur under heavy loads.
Feed forward control (N5-01 to N5-03)	Used to increase response for acceleration/deceleration or to reduce overshooting when there is low machine rigidity and the gain of the speed controller (ASR) cannot be increased. The inertia ratio between the load and motor and the acceleration time of the motor running alone must be set.



5

User Constants

This chapter describes all user constants that can be set in the Inverter.

User Constant Descriptions	5-2
Digital Operation Display Functions and Levels	5-3
User Constant Tables	5-8

User Constant Descriptions

This section describes the contents of the user constant tables.

◆ Description of User Constant Tables

User constant tables are structured as shown below. Here, b1-01 (Frequency Reference Selection) is used as an example.

Constant Number	Name	Description	Setting Range	Factory Setting	Change during Operation	Control Methods					MEMO BUS Register	Page
	Display					V/f	V/f with PG	Open-loop Vector 1	Flux Vector	Open Loop Vector 2		
b1-01	Reference selection	Set the frequency reference input method. 0: Digital Operator 1: Control circuit terminal (analog input) 2: MEMOBUS communications 3: Option Card 4: Pulse train input	0 to 4	1	No	Q	Q	Q	Q	Q	180H	-
	Reference Source											

- Constant Number: The number of the user constant.
- Name: The name of the user constant.
- Description: Details on the function or settings of the user constant.
- Setting Range: The setting range for the user constant.
- Factory Setting: The factory setting (each control method has its own factory setting. Therefore the factory setting changes when the control method is changed.)
Refer to page 5-83 for factory settings by control method.
- Change during Operation: Indicates whether or not the constant can be changed while the Inverter is in operation.
Yes: Changes possible during operation.
No: Changes not possible during operation.
- Control Methods: Indicates the control methods in which the user constant can be monitored or set.
Q: Items which can be monitored and set in either quick programming mode or advanced programming mode.
A: Items which can be monitored and set only in advanced programming mode.
No: Items which cannot be monitored or set for the control method.
- MEMOBUS Register: The register number used for MEMOBUS communications.
- Page: Reference page for more detailed information on the constant.

Digital Operation Display Functions and Levels

The following figure shows the Digital Operator display hierarchy for the Inverter.

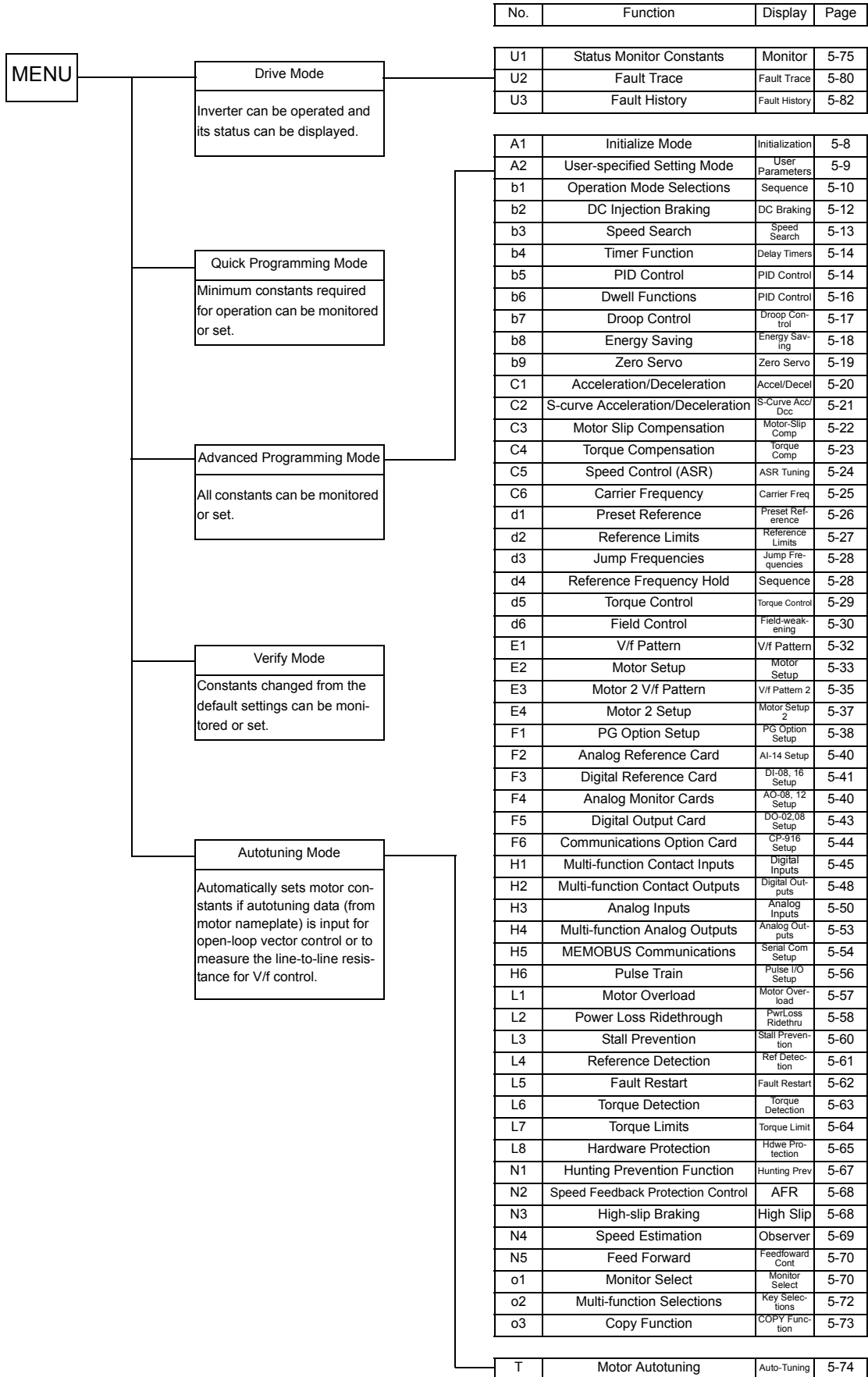

◆ User Constants Settable in Quick Programming Mode

The minimum user constants required for Inverter operation can be monitored and set in quick programming mode. The user constants displayed in quick programming mode are listed in the following table. These, and all other user constants, are also displayed in advanced programming mode.

Refer to the overview of modes on page 3-4 for an overview of quick programming mode.

Constant Number	Name	Description	Setting Range	Factory Setting	Change during Operation	Control Methods					MEMO BUS Register
	Display					V/f	V/f with PG	Open-loop Vector 1	Flux Vector	Open Loop Vector 2	
A1-02	Control method selection	Set the control method for the Inverter. 0: V/f control 1: V/f control with PG 2: Open-loop vector control 1 3: Flux vector control 4: Open-loop vector control 2	0 to 4	2	No	Q	Q	Q	Q	Q	102H
	Control Method										
b1-01	Reference selection	Set the frequency reference input method. 0: Digital Operator 1: Control circuit terminal (analog input) 2: MEMOBUS communications 3: Option Card 4: Pulse train input	0 to 4	1	No	Q	Q	Q	Q	Q	180H
	Reference Source										
b1-02	Operation method selection	Set the run command input method 0: Digital Operator 1: Control circuit terminal (sequence input) 2: MEMOBUS communications 3: Option Card	0 to 3	1	No	Q	Q	Q	Q	Q	181H
	Run Source										
b1-03	Stopping method selection	Select stopping method when stop command is sent. 0: Deceleration to stop 1: Coast to stop 2: DC braking stop (Stops faster than coast to stop, without regenerative operation.) 3: Coast to stop with timer (Run commands are disregarded during deceleration time.)	0 to 3	0	No	Q	Q	Q	Q	Q	182H
	Stopping Method										
C1-01	Acceleration time 1	Set the acceleration time in seconds for the output frequency to climb from 0% to 100%.	0.0 to 6000.0 *1	10.0 s	Yes	Q	Q	Q	Q	Q	200H
	Accel Time 1										
C1-02	Deceleration time 1	Set the deceleration time in seconds for the output frequency to fall from 100% to 0%.			Yes	Q	Q	Q	Q	Q	201H
	Decel Time 1										
C6-02	Carrier frequency selection	Select carrier wave fixed pattern. Select F to enable detailed settings using constants C6-03 to C6-05.	1 to F	6 *2	No	Q	Q	Q	Q	No	224H
	Carrier Freq Sel										

Constant Number	Name	Description	Setting Range	Factory Setting	Change during Operation	Control Methods					MEMO BUS Register
	Display					V/f	V/f with PG	Open-loop Vector 1	Flux Vector	Open Loop Vector 2	
C6-11	Carrier frequency for open-loop vector control 2	Select carrier frequency when open-loop vector control 2 is used. 1: 2.0kHz 2: 4.0kHz 3: 6.0kHz 4: 8.0kHz	1 to 4	4*2	No	No	No	No	No	Q	22DH
	Carrier Freq Sel										
d1-01	Frequency reference 1	Set the frequency reference in the unit specified in o1-03.									280H
	Reference 1										
d1-02	Frequency reference 2	Frequency reference when multi-step speed reference 1 is ON for a multi-function input.									281H
	Reference 2										
d1-03	Frequency reference 3	Frequency reference when multi-step speed reference 2 is ON for a multi-function input.	0 to 400.00*9								282H
	Reference 3										
d1-04	Frequency reference 4	Frequency reference when multi-step speed reference 1 and 2 are ON for a multi-function input.									283H
	Reference 4										
d1-17	Jog frequency reference	Frequency reference when Jog Frequency Selection, FJOG command, or RJOG command is ON for a multi-function input.									292H
	Jog Reference										
E1-01	Input voltage setting	Set the Inverter input voltage in 1 volt. This set value will be the basis for the protection functions.	155 to 255*3	200 V*3	No		Q	Q	Q	Q	300H
	Input Voltage										
E1-03	V/f pattern selection	0 to E: Select from 15 preset patterns. F: Custom user-set patterns (Applicable for setting E1-04 to E1-10).	0 to F	F	No		Q	Q	No	No	302H
	V/F Selection										

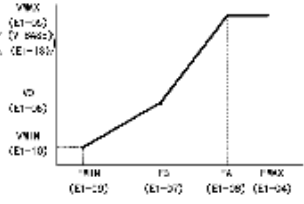
Constant Number	Name	Description	Setting Range	Factory Setting	Change during Operation	Control Methods					MEMO BUS Register	
	Display					V/f	V/f with PG	Open-loop Vector 1	Flux Vector	Open Loop Vector 2		
E1-04	Max. output frequency (FMAX)	 <p>To set V/f characteristics in a straight line, set the same values for E1-07 and E1-09. In this case, the setting for E1-08 will be disregarded. Always ensure that the four frequencies are set in the following manner: E1-04 (FMAX) ≥ E1-06 (FA) > E1-07 (FB) ≥ E1-09 (FMIN)</p>	40.0 to 400.0 ^{*9}	60.0 Hz ^{*4}	No	Q	Q	Q	Q	Q	303H	
	Max Frequency											
E1-05	Max. voltage (VMAX)		0.0 to 255.0 ^{*3}	200.0 V ^{*3*4}	No	Q	Q	Q	Q	Q	304H	
	Max Voltage											
E1-06	Base frequency (FA)		To set V/f characteristics in a straight line, set the same values for E1-07 and E1-09. In this case, the setting for E1-08 will be disregarded. Always ensure that the four frequencies are set in the following manner: E1-04 (FMAX) ≥ E1-06 (FA) > E1-07 (FB) ≥ E1-09 (FMIN)	0.0 to 400.0 ^{*9}	60.0 Hz ^{*4}	No	Q	Q	Q	Q	Q	305H
	Base Frequency											
E1-09	Min. output frequency (FMIN)		0.0 to 400.0 ^{*9}	0.5 Hz ^{*4}	No	Q	Q	Q	A	Q	308H	
	Min Frequency											
E1-13	Base voltage (VBASE)		Change this setting only when making advanced adjustments for V/f in the fixed outputs area. Normally, there is no need to make these settings.	0.0 to 255.0 ^{*3}	0.0 V ^{*5}	No	A	A	Q	Q	Q	30CH
	Base Voltage											
E2-01	Motor rated current	Set the motor rated current in amps. This set value becomes the base value for motor protection, torque limit, and torque control. It is set automatically when using autotuning.	0.32 to 6.40 ^{*7}	1.90 A ^{*6}	No	Q	Q	Q	Q	Q	30EH	
	Motor Rated FLA											
E2-04	Number of motor poles	Set the number of motor poles. The value is set automatically during autotuning.	2 to 48	4	No	No	Q	No	Q	Q	311H	
	Number of Poles											
E2-11	Motor rated output	Set the output of the motor in units of 0.01kW. This constant is automatically set during autotuning.	0.00 to 650.000	0.40 ^{*10}	No	Q	Q	Q	Q	Q	318H	
	Mtr Rated Power											
F1-01	PG constant	Set the number of pulses per rotation for the PG (pulse generator or encoder) being used. (Do not set as a multiple.)	0 to 60000	600	No	No	Q	No	Q	No	380H	
	PG Pulses/ Rev											
H4-02	Gain (terminal FM)	Set the voltage level gain for multi-function analog output 1. Set the number of multiples of 10 V to be output as the 100% output for the monitor items. Voltage output from the terminals, however, have a 10 V max. meter calibration function.	0.00 to 2.50	1.00	Yes	Q	Q	Q	Q	Q	41EH	
	Terminal FM Gain											

Constant Number	Name	Description	Setting Range	Factory Setting	Change during Operation	Control Methods					MEMO BUS Register
	Display					V/f	V/f with PG	Open-loop Vector 1	Flux Vector	Open Loop Vector 2	
H4-05	Gain (terminal AM)	Set the voltage level gain for multi-function analog output 2.	0.00 to 2.50	0.50	Yes	Q	Q	Q	Q	Q	421H
	Terminal AM Gain	Set the number of multiples of 10 V to be output as the 100% output for the monitor items. Voltage output from the terminals, however, have a 10 V max. meter calibration function.									
L1-01	Motor protection selection	Set to enable or disable the motor overload protection function using the electronic thermal relay.	0 to 3	1	No	Q	Q	Q	Q	Q	480H
	MOL Fault Select	0: Disabled 1: General-purpose motor protection 2: Inverter motor protection 3: Vector motor protection In some applications when the Inverter power supply is turned off, the thermal value is reset, so even if this constant is set to 1, protection may not be effective. When several motors are connected to one Inverter, set to 0 and ensure that each motor is installed with a protection device.									
L3-04	Stall prevention selection during deceleration	0: Disabled (Deceleration as set. If deceleration time is too short, a main circuit overvoltage may result.) 1: Enabled (Deceleration is stopped when the main circuit voltage exceeds the overvoltage level. Deceleration restarts when voltage is returned.)	0 to 3 *11	1	No	Q	Q	Q	Q	Q	492H
	StallP Decel Sel	2: Intelligent deceleration mode (Deceleration rate is automatically adjusted so that in Inverter can decelerate in the shortest possible time. Set deceleration time is disregarded.) 3: Enabled (with Braking Resistor Unit) *8 When a braking option (Braking Resistor, Braking Resistor Unit, Braking Unit) is used, always set to 0 or 3.									

* 1. The setting ranges for acceleration/deceleration times depends on the setting of C1-10 (Acceleration/deceleration Time Setting Unit). If C1-10 is set to 0, the setting range is 0.00 to 600.00 (s).

* 2. The factory setting depends on the Inverter capacity.

* 3. These are values for a 200 V class Inverter. Values for a 400 V class Inverter are double.

* 4. The factory setting will change when the control method is changed. (Open-loop vector 1 factory settings are given.)

* 5. After autotuning, E1-13 will contain the same value as E1-05.

* 6. The factory setting depends on the Inverter capacity. (The value for a 200 V Class Inverter for 0.4 kW is given.)

* 7. The setting range is from 10% to 200% of the Inverter rated output current. (The value for a 200 V Class Inverter for 0.4 kW is given.)

* 8. L3-04 cannot be set to 3 for flux vector control or open-loop vector control 2.

* 9. The setting range is 0 to 66.0 for open-loop vector control 2.

* 10. The same capacity as the Inverter will be set by initializing the constants.

* 11. The setting range is 0 to 2 for flux vector control and open-loop vector control 2.

User Constant Tables

◆ A: Setup Settings

The following settings are made with the environment constants (A constants): Language displayed on the Digital Operator, access level, control method, initialization of constants.

■ Initialize Mode: A1

User constants for the environment modes are shown in the following table.

Constant Number	Name	Description	Setting Range	Factory Setting	Change during Operation	Control Methods					MEMO BUS Register	Page
	Display					V/f	V/f with PG	Open Loop Vector 1	Flux Vector	Open Loop Vector 2		
A1-00	Language selection for Digital Operator display	Used to select the language displayed on the Digital Operator (LCD). 0: English 1: Japanese 2: German 3: French 4: Italian 5: Spanish 6: Portuguese This constant is not initialized by the initialize operation.	0 to 6	1	Yes	A	A	A	A	A	100H	-
	Select Language											
A1-01	Constant access level	Used to set the constant access level (set/read.) 0: Monitoring only (Monitoring drive mode and setting A1-01 and A1-04.) 1: Used to select user constant (Only constants set in A2-01 to A2-32 can be read and set.) 2: Advanced (Constants can be read and set in both quick programming mode and advanced programming (A) mode.)	0 to 2	2	Yes	A	A	A	A	A	101H	6-139 6-141
	Access Level											
A1-02	Control method selection	Used to select the control method for the Inverter 0: V/f control 1: V/f with PG feedback 2: Open-loop vector control 1 3: Flux vector 4: Open-loop vector control 2 This constant is not initialized by the initialize operation.	0 to 4	2	No	Q	Q	Q	Q	Q	102H	4-5 4-7 4-16
	Control Method											

Constant Number	Name	Description	Setting Range	Factory Setting	Change during Operation	Control Methods					MEMO BUS Register	Page
	Display					V/f	V/f with PG	Open Loop Vector 1	Flux Vector	Open Loop Vector 2		
A1-03	Initialize	Used to initialize the constants using the specified method. 0: No initializing 1110: Initializes using the User constants 2220: Initializes using a two-wire sequence. (Initializes to the factory setting.) 3330: Initializes using a three-wire sequence.	0 to 3330	0	No	A	A	A	A	A	103H	-
	Init Parameters											
A1-04	Password	Password input when a password has been set in A1-05. This function write-protects some constants of the initialize mode. If the password is changed, A1-01 to A1-03 and A2-01 to A2-32 constants can no longer be changed. (Programming mode constants can be changed.)	0 to 9999	0	No	A	A	A	A	A	104H	6-140
	Enter Password											
A1-05	Password setting	Used to set a four digit number as the password. This constant is not usually displayed. When the Password (A1-04) is displayed, hold down the RESET Key and press the Menu Key and the password will be displayed.	0 to 9999	0	No	A	A	A	A	A	105H	6-140
	Select Password											

■ User-set Constants: A2

The constants set by the user are listed in the following table.

Constant Number	Name	Description	Setting Range	Factory Setting	Change during Operation	Control Methods					MEMO BUS Register	Page
	Display					V/f	V/f with PG	Open Loop Vector 1	Flux Vector	Open Loop Vector 2		
A2-01 to A2-32	User setting constants	Used to set the constant numbers that can be set/read. Maximum 32. Effective when the Constant Access Level (A1-01) is set to User Program (1). Constants set in constants A2-01 to A2-32 can be set/read in programming mode.	b1-01 to o3-02	-	No	A	A	A	A	A	106H to 125H	6-141
	User Param 1 to 32											

◆ Application Constants: b

The following settings are made with the application constants (B constants): Operation method selection, DC injection braking, speed searching, timer functions, dwell functions, and energy saving functions.

■ Operation Mode Selections: b1

User constants for operation mode selection are shown in the following table.

Constant Number	Name	Description	Setting Range	Factory Setting	Change during Operation	Control Methods					MEMO BUS Register	Page
	Display					V/f	V/f with PG	Open Loop Vector 1	Flux Vector	Open Loop Vector 2		
b1-01	Reference selection	Set the frequency reference input method. 0: Digital Operator 1: Control circuit terminal (analog input) 2: MEMOBUS communications 3: Option Card 4: Pulse train input	0 to 4	1	No	Q	Q	Q	Q	Q	180H	4-5 6-2 6-66 6-83
	Reference Source											
b1-02	Operation method selection	Set the run command input method. 0: Digital Operator 1: Control circuit terminal (sequence input) 2: MEMOBUS communications 3: Option Card	0 to 3	1	No	Q	Q	Q	Q	Q	181H	4-5 6-7 6-66 6-83
	Run Source											
b1-03	Stopping method selection	Used to set the stopping method used when a stop command is input. 0: Deceleration to stop 1: Coast to stop 2: DC injection braking stop (Stops faster than coast to stop, no regenerative operation.) 3: Coast to stop with timer (Run commands are disregarded during deceleration.)	0 to 3*	0	No	Q	Q	Q	Q	Q	182H	4-6 6-9
	Stopping Method											
b1-04	Prohibition of reverse operation	0: Reverse enabled 1: Reverse disabled	0 or 1	0	No	A	A	A	A	A	183H	6-54
	Reverse Oper											

Constant Number	Name	Description	Setting Range	Factory Setting	Change during Operation	Control Methods					MEMO BUS Register	Page
	Display					V/f	V/f with PG	Open Loop Vector 1	Flux Vector	Open Loop Vector 2		
b1-05	Operation selection for setting E1-09 or less	Used to set the method of operation when the frequency reference input is less than the minimum output frequency (E1-09). 0: Run at frequency reference (E1-09 not effective). 1: STOP (Frequencies below E1-09 in the coast to stop state.) 2: Run at min. frequency. (E1-09) 3: Run at zero speed (Frequencies below E1-09 are zero)	0 to 3	0	No	No	No	No	A	No	184H	6-9
	Zero-Speed Oper											
b1-06	Read sequence input twice	Used to set the responsiveness of the control inputs (forward/reverse and multi-function inputs.) 0: Two scans every 2 ms (Use for fast responses.) 1: Two scans every 5 ms (Use for possible malfunction due to noise.)	0 or 1	1	No	A	A	A	A	A	185H	-
	Cntl Input Scans											
b1-07	Operation selection after switching to remote mode	Used to set the operation mode by switching to the Remote mode using the Local/Remote Key. 0: Run signals that are input during mode switching are disregarded. (Input Run signals after switching the mode.) 1: Run signals become effective immediately after switching to the Remote mode.	0 or 1	0	No	A	A	A	A	A	186H	-
	LOC/REM RUN Sel											
b1-08	Run command selection in programming modes	Used to set an operation interlock in programming modes. 0: Cannot operate. 1: Can operate (Disabled when Digital Operator is set to select run command (when b1-02 = 0).	0 or 1	0	No	A	A	A	A	A	187H	-
	RUN CMD at PRG											

* The setting range is 0 or 1 for flux vector control and open-loop vector control 2.

■DC Injection Braking: b2

User constants for injection braking are shown in the following table.

Constant Number	Name	Description	Setting Range	Factory Setting	Change during Operation	Control Methods					MEMO BUS Register	Page
	Display					V/f	V/f with PG	Open Loop Vector 1	Flux Vector	Open Loop Vector 2		
b2-01	Zero speed level (DC injection braking starting frequency)	Used to set the frequency which starts DC injection braking in units of Hz when deceleration to stop is selected. When b2-01 is less than E1-09, E1-09 becomes the DC injection braking starting frequency.	0.0 to 10.0	0.5 Hz	No	A	A	A	A	A	189H	6-9
	DCInj Start Freq											
b2-02	DC injection braking current	Sets the DC injection braking current as a percentage of the Inverter rated current.	0 to 100	50%	No	A	A	A	No	No	18AH	6-9 6-13
	DCInj Current											
b2-03	DC injection braking time at start	Used to set the time to perform DC injection braking at start in units of 1 second. Used to stop coasting motor and restart it. When the set value is 0, DC injection braking at start is not performed.	0.00 to 10.00	0.00 s	No	A	A	A	A	A	18BH	6-13
	DCInj Time@Start											
b2-04	DC injection braking time at stop	Used to set the time to perform DC injection braking at stop in units of 1 second. Used to prevent coasting after the stop command is input. When the set value is 0.00, DC injection braking at stop is not performed.	0.00 to 10.00	0.50 s	No	A	A	A	A	A	18CH	6-9
	DCInj Time@Stop											
b2-08	Magnetic flux compensation volume	Sets the magnetic flux compensation as a percentage of the no-load current.	0 to 1000	0%	No	No	No	A	No	No	190H	-
	Field Comp											

■Speed Search: b3

User constants for the speed search are shown in the following table.

Constant Number	Name	Description	Setting Range	Factory Setting	Change during Operation	Control Methods					MEMO BUS Register	Page
	Display					V/f	V/f with PG	Open Loop Vector 1	Flux Vector	Open Loop Vector 2		
b3-01	Speed search selection (current detection or speed calculation)	Enables/disables the speed search function for the run command and sets the speed search method. 0: Disabled, speed calculation 1: Enabled, speed calculation 2: Disabled, current detection 3: Enabled, current detection	0 to 3	2*	No	A	A	A	No	A	191H	6-56
	SpdSrCh at Start	Speed Calculation: When the search is started, the motor speed is calculated and acceleration/deceleration is performed from the calculated speed to the specified frequency (motor direction is also searched). Current Detection: The speed search is started from the frequency when power was momentarily lost and the maximum frequency, and the speed is detected at the search current level.										
b3-02	Speed search operating current (current detection)	Sets the speed search operation current as a percentage, taking the Inverter rated current as 100%. Not usually necessary to set.	0 to 200	100%*	No	A	No	A	No	A	192H	6-56
	SpdSrCh Current	When restarting is not possible with the factory settings, reduce the value.										
b3-03	Speed search deceleration time (current detection)	Sets the output frequency deceleration time during speed search in 1-second units. Set the time for deceleration from the maximum output frequency to the minimum output frequency.	0.1 to 10.0	2.0 s	No	A	No	A	No	No	193H	6-56
	SpdSrCh Dec Time											
b3-05	Speed search wait time (current detection or speed calculation)	Sets the contactor operating delay time when there is a contactor on the output side of the Inverter. When a speed search is performed after recovering from a momentary power loss, the search operation is delayed by the time set here.	0.0 to 20.0	0.2 s	No	A	A	A	A	A	195H	6-56
	Search Delay											

* The factory setting will change when the control method is changed. (Open-loop vector 1 factory settings are given.)

■ Timer Function: b4

User constants for timer functions are shown in the following table.

Con- stant Number	Name	Description	Setting Range	Factory Setting	Change during Opera- tion	Control Methods					MEMO BUS Regis- ter	Page
	Display					V/f	V/f with PG	Open Loop Vec- tor 1	Flux Vec- tor	Open Loop Vec- tor 2		
b4-01	Timer func- tion ON- delay time	Sets the timer function out- put ON-delay time (dead band) for the timer function input, in 1-second units. Enabled when a timer func- tion is set in H1-□□ or H2- □□.	0.0 to 300.0	0.0 s	No	A	A	A	A	A	1A3H	6-93
	Delay-ON Timer											
b4-02	Timer func- tion OFF- delay time	Sets the timer function out- put OFF-delay time (dead band) for the timer function input, in 1-second units. Enabled when a timer func- tion is set in H1-□□ or H2- □□.	0.0 to 300.0	0.0 s	No	A	A	A	A	A	1A4H	6-93
	Delay-OFF Timer											

■ PID Control: b5

User constants for PID control are shown in the following table.

Con- stant Number	Name	Description	Setting Range	Factory Setting	Change during Opera- tion	Control Methods					MEMO BUS Regis- ter	Page
	Display					V/f	V/f with PG	Open Loop Vec- tor 1	Flux Vec- tor	Open Loop Vec- tor 2		
b5-01	PID control mode selec- tion	0: Disabled 1: Enabled (Deviation is D- controlled.) 2: Enabled (Feedback value is D-controlled.) 3: PID control enabled (frequency reference + PID output, D control of deviation) 4: PID control enabled (frequency reference + PID output, D control of feedback value).	0 to 4	0	No	A	A	A	A	A	1A5H	6-95
	PID Mode											
b5-02	Proportional gain (P)	Sets P-control proportional gain as a percentage. P-control is not performed when the setting is 0.00.	0.00 to 25.00	1.00	Yes	A	A	A	A	A	1A6H	6-95
	PID Gain											
b5-03	Integral (I) time	Sets I-control integral time in 1-second units. I-control is not performed when the setting is 0.0.	0.0 to 360.0	1.0 s	Yes	A	A	A	A	A	1A7H	6-95
	PID I Time											
b5-04	Integral (I) limit	Sets the I-control limit as a percentage of the maximum output frequency.	0.0 to 100.0	100.0%	Yes	A	A	A	A	A	1A8H	6-95
	PID I Limit											
b5-05	Derivative (D) time	Sets D-control derivative time in 1-second units. D-control is not performed when the setting is 0.00.	0.00 to 10.00	0.00 s	Yes	A	A	A	A	A	1A9H	6-95
	PID D Time											

Constant Number	Name	Description	Setting Range	Factory Setting	Change during Operation	Control Methods					MEMO BUS Register	Page
	Display					V/f	V/f with PG	Open Loop Vector 1	Flux Vector	Open Loop Vector 2		
b5-06	PID limit	Sets the limit after PID-control as a percentage of the maximum output frequency.	0.0 to 100.0	100.0%	Yes	A	A	A	A	A	1AAH	6-95
	PID Limit											
b5-07	PID offset adjustment	Sets the offset after PID-control as a percentage of the maximum output frequency.	-100.0 to +100.0	0.0%	Yes	A	A	A	A	A	1ABH	6-95
	PID Offset											
b5-08	PID primary delay time constant	Sets the time constant for low pass filter for PID-control outputs in 1-second units. Not usually necessary to set.	0.00 to 10.00	0.00 s	Yes	A	A	A	A	A	1ACH	6-95
	PID Delay Time											
b5-09	PID output characteristics selection	Select forward/reverse for PID output. 0: PID output is forward. 1: PID output is reverse (highlights the output code)	0 or 1	0	No	A	A	A	A	A	1ADH	6-95
	Output Level Sel											
b5-10	PID output gain	Sets output gain.	0.0 to 25.0	1.0	No	A	A	A	A	A	1AEH	6-95
	Output Gain											
b5-11	PID reverse output selection	0: 0 limit when PID output is negative. 1: Reverses when PID output is negative. 0 limit when reverse prohibit is selected using b1-04.	0 or 1	0	No	A	A	A	A	A	1AFH	6-95
	Output Rev Sel											
b5-12	Selection of PID feedback command loss detection	0: No detection of loss of PID feedback. 1: Detection of loss of PID feedback. Operation continues during detection, with the malfunctioning contact not operating. 2: Detection of loss of PID feedback. Coasts to stop during detection, and fault contact operates.	0 to 2	0	No	A	A	A	A	A	1B0H	6-96
	Fb los Det Sel											
b5-13	PID feedback command loss detection level	Sets the PID feedback loss detection level as a percent units, with the maximum output frequency at 100%.	0 to 100	0%	No	A	A	A	A	A	1B1H	6-96
	Fb los Det Lvl											
b5-14	PID feedback command loss detection time	Sets the PID feedback loss detection level in s units.	0.0 to 25.5	1.0 s	No	A	A	A	A	A	1B2H	6-96
	Fb los Det Time											

Constant Number	Name	Description	Setting Range	Factory Setting	Change during Operation	Control Methods					MEMO BUS Register	Page
	Display					V/f	V/f with PG	Open Loop Vector 1	Flux Vector	Open Loop Vector 2		
b5-15	PID sleep function operation level	Set the PID sleep function start level as a frequency.	0.0 to 400.0	0.0 Hz	No	A	A	A	A	A	1B3H	6-96
	PID Sleep Level											
b5-16	PID sleep operation delay time	Set the delay time until the PID sleep function starts in seconds.	0.0 to 25.5	0.0 s	No	A	A	A	A	A	1B4H	6-96
	PID Sleep Time											
b5-17	Accel/decel time for PID reference	Set the accel/decel time for PID reference in seconds.	0.0 to 25.5	0.0 s	No	A	A	A	A	A	1B5H	6-96
	PID SFS Time											

■ Dwell Functions: b6

User constants for dwell functions are shown in the following table.

Constant Number	Name	Description	Setting Range	Factory Setting	Change during Operation	Control Methods					MEMO BUS Register	Page
	Display					V/f	V/f with PG	Open Loop Vector 1	Flux Vector	Open Loop Vector 2		
b6-01	Dwell frequency at start	<p>The dwell function is used to output frequency temporarily when driving a motor with a heavy load.</p>	0.0 to 400.0	0.0 Hz	No	A	A	A	A	A	1B6H	6-19
	Dwell Ref @Start											
b6-02	Dwell time at start		0.0 to 10.0	0.0 s	No	A	A	A	A	A	1B7H	6-19
	Dwell Time @Start											
b6-03	Dwell frequency at stop		0.0 to 400.0	0.0 Hz	No	A	A	A	A	A	1B8H	6-19
	Dwell Ref @Stop											
b6-04	Dwell time at stop		0.0 to 10.0	0.0 s	No	A	A	A	A	A	1B9H	6-19
	Dwell Time @Stop											

■DROOP Control: b7

User constants for droop functions are shown in the following table.

Constant Number	Name	Description	Setting Range	Factory Setting	Change during Operation	Control Methods					MEMO BUS Register	Page
	Display					V/f	V/f with PG	Open Loop Vector 1	Flux Vector	Open Loop Vector 2		
b7-01	Droop control gain	Sets the slip as a percentage of maximum frequency when the maximum output frequency is specified and the rated torque occurs. Droop-control is not performed when the setting is 0.0.	0.0 to 100.0	0.0%	Yes	No	No	No	A	A	1CAH	4-18 6-127
	Droop Quantity											
b7-02	Droop control delay time	Droop control responsiveness constant When hunting or oscillation occurs, increase the value.	0.03 to 2.00	0.05 s	No	A	A	A	A	A	1A4H	4-18 6-127
	Droop Delay Time											

■Energy Saving: b8

User constants for energy-saving control functions are shown in the following table.

Constant Number	Name	Description	Setting Range	Factory Setting	Change during Operation	Control Methods					MEMO BUS Register	Page
	Display					V/f	V/f with PG	Open Loop Vector 1	Flux Vector	Open Loop Vector 2		
b8-01	Energy-saving mode selection	Select whether to enable or disable energy-saving control. 0: Disable 1: Enable	0 or 1	0	No	A	A	A	A	A	1CCH	-
	Energy Save Sel											
b8-02	Energy-saving gain	Set the energy-saving gain with the open-loop vector control method.	0.0 to 10.0	0.7 *1	Yes	No	No	A	A	A	1CDH	-
	Energy Save Gain											
b8-03	Energy-saving filter time constant	Set the energy-saving filter time constant with the open-loop vector control method.	0.00 to 10.0	0.50 s *2	Yes	No	No	A	A	A	1CEH	-
	Energy Save F.T											
b8-04	Energy-saving coefficient	Set the maximum motor efficiency value. Set the motor rated capacity in E2-11, and adjust the value by 5% at a time until output power reaches a minimum value.	0.0 to 655.00	*3 *4	No	A	A	No	No	No	1CFH	-
	Energy Save COEF											
b8-05	Power detection filter time constant	Set the time constant for output power detection.	0 to 2000	20 ms	No	A	A	No	No	No	1D0H	-
	kW Filter Time											
b8-06	Search operation voltage limiter	Set the limit value of the voltage control range during search operation. Perform search operation to optimize operations using minute variations in voltage using energy-saving control. Set to 0 to disable the search operation. 100% is the motor base voltage.	0 to 100	0%	No	A	A	No	No	No	1D1H	-
	Search V Limit											

* 1. The factory setting is 1.0 when using V/f control with PG.

* 2. The factory setting is 2.00 s when Inverter capacity is 55 kW min. The factory setting will change when the control method is changed. (Open-loop vector 1 factory settings are given.)

* 3. The same capacity as the Inverter will be set by initializing the constants.

* 4. The factory settings depend on the Inverter capacity.

■Zero Servo: b9

User constants for dwell functions are shown in the following table.

Constant Number	Name	Description	Setting Range	Factory Setting	Change during Operation	Control Methods					MEMO BUS Register	Page
	Display					V/f	V/f with PG	Open Loop Vector 1	Flux Vector	Open Loop Vector 2		
b9-01	Zero-servo gain	Adjust the strength of the zero-servo lock.	0 to 100	5	No	No	No	No	A	No	1DAH	
	Zero Servo Gain	Enabled when the “zero-servo command” is set for the multi-function input. When the zero-servo command has been input and the frequency reference drop below excitation level (b2-01), a position control loop is created and the motor stops. Increasing the zero-servo gain in turn increases the strength of the lock. Increasing it by too much will cause oscillation.										
b9-02	Zero-servo completion width	Sets the output width of the P-lock completion signal.	0 to 16383	10	No	No	No	No	A	No	1DBH	
	Zero Servo Count	Enabled when the “zero-servo completion (end)” is set for a multi-function input. The zero-servo completion signal is ON when the current position is within the range (the zero-servo position + zero-servo completion width.) Set the allowable position displacement from the zero-servo position to 4 times the pulse rate of the PG (pulse generator, encoder) in use.										

◆ Autotuning Constants: C

The following settings are made with the autotuning constants (C constants): Acceleration/deceleration times, s-curve characteristics, slip compensation, torque compensation, speed control, and carrier frequency functions.

■ Acceleration/Deceleration: C1

User constants for acceleration and deceleration times are shown in the following table.

Constant Number	Name	Description	Setting Range	Factory Setting	Change during Operation	Control Methods					MEMO BUS Register	Page	
	Display					V/f	V/f with PG	Open Loop Vector 1	Flux Vector	Open Loop Vector 2			
C1-01	Acceleration time 1	Sets the acceleration time to accelerate from 0 to the maximum output frequency, in 1-second units.	0.0 to 6000.0 *	10.0 s	Yes	Q	Q	Q	Q	Q	200H	4-5 6-15	
	Accel Time 1												
C1-02	Deceleration time 1	Sets the deceleration time to decelerate from the maximum output frequency to 0, in 1-second units.			Yes	Q	Q	Q	Q	Q	Q	201H	4-5 6-15
	Decel Time 1												
C1-03	Acceleration time 2	The acceleration time when the multi-function input "accel/decel time 1" is set to ON.			Yes	A	A	A	A	A	A	202H	6-15
	Accel Time 2												
C1-04	Deceleration time 2	The deceleration time when the multi-function input "accel/decel time 1" is set to ON.			Yes	A	A	A	A	A	A	203H	6-15
	Decel Time 2												
C1-05	Acceleration time 3	The acceleration time when the multi-function input "accel/decel time 2" is set to ON.			No	A	A	A	A	A	A	204H	6-15
	Accel Time 3												
C1-06	Deceleration time 3	The deceleration time when the multi-function input "accel/decel time 2" is set to ON.			No	A	A	A	A	A	A	205H	6-15
	Decel Time 3												
C1-07	Acceleration time 4	The acceleration time when the multi-function input "accel/decel time 1" and "accel/decel time 2" are set to ON.			No	A	A	A	A	A	A	206H	6-15
	Accel Time 4												
C1-08	Deceleration time 4	The deceleration time when the multi-function input "accel/decel time 1" and "accel/decel time 2" are set to ON.			No	A	A	A	A	A	A	207H	6-15
	Decel Time 4												
C1-09	Emergency stop time	The deceleration time when the multi-function input "Emergency (fast) stop" is set to ON. This function can be used a stopped method when a fault has been detected.			No	A	A	A	A	A	A	208H	6-14
	Fast Stop Time												

Constant Number	Name	Description	Setting Range	Factory Setting	Change during Operation	Control Methods					MEMO BUS Register	Page
	Display					V/f	V/f with PG	Open Loop Vector 1	Flux Vector	Open Loop Vector 2		
C1-10	Accel/decel time setting unit	0: 0.01-second units 1: 0.1-second units	0 or 1	1	No	A	A	A	A	A	209H	6-15
	Acc/Dec Units											
C1-11	Accel/decel time switching frequency	Sets the frequency for automatic acceleration/deceleration switching. Below set frequency: Accel/decel time 4 Above set frequency: Accel/decel time 1 The multi-function input "accel/decel time 1" or "accel/decel time 2" take priority.	0.0 to 400.0	0.0 Hz	No	A	A	A	A	A	20AH	-
	Acc/Dec SW Freq											

* The setting range for acceleration/deceleration times will depends on the setting for C1-10. When C1-10 is set to 0, the setting range for acceleration/deceleration times becomes 0.00 to 600.00 seconds.

■S-curve Acceleration/Deceleration: C2

User constants for S-curve characteristics are shown in the following table.

Constant Number	Name	Description	Setting Range	Factory Setting	Change during Operation	Control Methods					MEMO BUS Register	Page
	Display					V/f	V/f with PG	Open Loop Vector 1	Flux Vector	Open Loop Vector 2		
C2-01	S-curve characteristic time at acceleration start	All sections of the S-curve characteristic time are set in seconds units. When the S-curve characteristic time is set, the accel/decel times will increase by only half of the S-curve characteristic times at start and end.	0.00 to 2.50	0.20 s	No	A	A	A	A	A	20BH	-
	SCrv Acc @ Start											
C2-02	S-curve characteristic time at acceleration end		0.00 to 2.50	0.20 s	No	A	A	A	A	A	20CH	-
	SCrv Acc @ End											
C2-03	S-curve characteristic time at deceleration start		0.00 to 2.50	0.20 s	No	A	A	A	A	20DH	-	
	SCrv Dec @ Start											
C2-04	S-curve characteristic time at deceleration end		0.00 to 2.50	0.00 s	No	A	A	A	A	A	20EH	-
	SCrv Dec @ End											

■ Motor Slip Compensation: C3

User constants for slip compensation are shown in the following table.

Constant Number	Name	Description	Setting Range	Factory Setting	Change during Operation	Control Methods					MEMO BUS Register	Page
	Display					V/f	V/f with PG	Open Loop Vector 1	Flux Vector	Open Loop Vector 2		
C3-01	Slip compensation gain	Used to improve speed accuracy when operating with a load. Usually setting is not necessary. Adjust this constant at the following times. <ul style="list-style-type: none"> When actual speed is low, increase the set value. When actual speed is high, decrease the set value. 	0.0 to 2.5	1.0*	Yes	A	No	A	A	A	20FH	4-16 6-32
	Slip Comp Gain											
C3-02	Slip compensation primary delay time	Slip compensation primary delay time is set in ms units. Usually setting is not necessary. Adjust this constant at the following times. <ul style="list-style-type: none"> Reduce the setting when slip compensation response is slow. When speed is not stabilized, increase the setting. 	0 to 10000	200 ms*	No	A	No	A	No	No	210H	4-16 6-32
	Slip Comp Time											
C3-03	Slip compensation limit	Sets the slip compensation limit as a percentage of motor rated slip.	0 to 250	200%	No	A	No	A	No	No	211H	6-32
	Slip Comp Limit											
C3-04	Slip compensation selection during regeneration	0: Disabled. 1: Enabled. When the slip compensation during regeneration function has been activated, as regeneration capacity increases momentarily, it may be necessary to use a braking option (braking resistor, Braking Resistor Unit or Braking Unit.)	0 or 1	0	No	A	No	A	No	No	212H	6-32
	Slip Comp Regen											
C3-05	Output voltage limit operation selection	0: Disabled. 1: Enabled. (The motor flux will be lowered automatically when the output voltage become saturated.)	0 or 1	0	No	No	No	A	A	A	213H	6-32
	Output V limit											

* The factory setting will change when the control method is changed. (Open-loop vector 1 factory settings are given.)

■ Torque Compensation: C4

User constants for are torque compensation shown in the following table.

Con- stant Number	Name	Description	Setting Range	Factory Setting	Change during Opera- tion	Control Methods					MEMO BUS Regis- ter	Page
	Display					V/f	V/f with PG	Open Loop Vec- tor 1	Flux Vec- tor	Open Loop Vec- tor 2		
C4-01	Torque com- pensation gain	Sets torque compensation gain as a ratio. Usually setting is not neces- sary. Adjust in the following cir- cumstances: <ul style="list-style-type: none"> • When the cable is long; increase the set value. • When the motor capacity is smaller than the Inverter capacity (Max. applicable motor capacity), increase the set values. • When the motor is oscillat- ing, decrease the set val- ues. Adjust the output current range at minimum speed rota- tion so that it does not exceed the Inverter rated output cur- rent. Do not alter the torque com- pensation gain from its default (1.00) when using the open-loop vector control method.	0.00 to 2.50	1.00	Yes	A	A	A	No	No	215H	4-16 6-35
	Torq Comp Gain											
C4-02	Torque com- pensation primary delay time constant	The torque compensation delay time is set in ms units. Usually setting is not neces- sary. Adjust in the following cir- cumstances: <ul style="list-style-type: none"> • When the motor is oscillat- ing, increase the set values. • When the responsiveness of the motor is low, decrease the set values. 	0 to 10000	20 ms *	No	A	A	A	No	No	216H	4-16 6-35
	Torq Comp Time											
C4-03	Forward starting torque	Sets the forward starting torque as a percentage of the motor rated torque.	0.0 to 200.0	0.0%	No	No	No	A	No	No	217H	-
	F TorqCmp@ start											
C4-04	Reverse starting torque	Sets the reverse starting torque as a percentage of the motor rated torque.	-200.0 to 0.0	0.0%	No	No	No	A	No	No	218H	-
	R TorqCmp@ start											
C4-05	Starting torque time constant	Sets the delay time in ms for starting torque. The filter is disabled if the time is set to 0 to 4 ms.	0 to 200	10 ms	No	No	No	A	No	No	219H	-
	TorqCmp DelayT											

* The factory setting will change when the control method is changed. (Open-loop vector 1 factory settings are given.)

■ Speed Control (ASR): C5

User constants for speed control are shown in the following table.

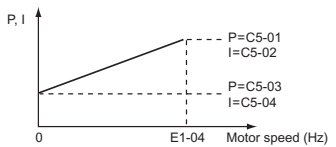
Constant Number	Name	Description	Setting Range	Factory Setting	Change during Operation	Control Methods					MEMO BUS Register	Page
	Display					V/f	V/f with PG	Open Loop Vector 1	Flux Vector	Open Loop Vector 2		
C5-01	ASR proportional gain 1	Sets the proportional gain of the speed loop (ASR.)	0.00 to 300.00 *2	0.20*	Yes	No	A	No	A	A	21BH	-
	ASR P Gain 1											
C5-02	ASR integral (I) time 1	Sets the integral time of the speed loop (ASR) in 1-second units.	0.000 to 10.000	0.500 s*	Yes	No	A	No	A	A	21CH	-
	ASR I Time 1											
C5-03	ASR proportional gain 2	Usually setting is not necessary. Set to change the rotational speed gain.	0.00 to 300.00 *2	0.20*	Yes	No	A	No	A	A	21DH	-
	ASR P Gain 2											
C5-04	ASR integral (I) time 2		0.000 to 10.000	0.500 s*	Yes	No	A	No	A	A	21EH	-
	ASR I Time 2											
C5-05	ASR limit	Sets the upper limit for the compensation frequency for the speed control loop (ASR) to a percentage of the maximum output frequency.	0.0 to 20.0	5.0%	No	No	A	No	No	No	21FH	-
	ASR Limit											
C5-06	ASR primary delay time	Sets the filter time constant; the time from the speed loop to the torque command output, in units of 1-second. Usually setting is not necessary.	0.000 to 0.500	0.004 *	No	No	No	No	A	A*	220H	-
	ASR Delay Time											
C5-07	ASR switching frequency	Set the frequency for switching between Proportion Gain 1, 2 and Integral Time 1, 2 in Hz units.	0.0 to 400.0	0.0	No	No	No	No	A	A	221H	-
	ASR Gain SW Freq											
C5-08	ASR integral (I) limit	Set to a small value to prevent any radical load change. Set to 100% of the maximum output frequency.	0 to 400	400	No	No	No	No	A	A	222H	-
	ASR I Limit											

* 1. When the control method is changed, the Inverter reverts to factory settings. (The flux vector control factory settings will be displayed.)

* 2. The setting range is 1.00 to 3.00 for flux vector control and open-loop vector control 2.

Carrier Frequency: C6

User constants for the carrier frequency are shown in the following table.

Constant Number	Name	Description	Setting Range	Factory Setting	Change during Operation	Control Methods					MEMO BUS Register	Page
	Display					V/f	V/f with PG	Open Loop Vector 1	Flux Vector	Open Loop Vector 2		
C6-02	Carrier frequency selection	Select carrier wave fixed pattern. Select F to enable detailed settings using constants C6-03 to C6-05.	1 to F	6 *2	No	Q	Q	Q	A	No *5	224H	4-6 4-16 6-38
	Carrier Freq Sel											
C6-03	Carrier frequency upper limit	Set the carrier frequency upper limit and lower limit in kHz units. The carrier frequency gain is set as follows: With the vector control method, the upper limit of the carrier frequency is fixed in C6-03.	2.0 to 15.0 *3 *4	15.0 kHz *2	No	A	A	A	A	No	225H	-
	Carrier Freq Max											
C6-04	Carrier frequency lower limit		0.4 to 15.0 *3 *4	15.0 kHz *2	No	A	A	No	No	No	226H	-
	Carrier Freq Min											
C6-05	Carrier frequency proportional gain		00 to 99 *4	00	No	A	A	No	No	No	227H	-
	Carrier Freq Gain											
C6-11	Carrier frequency selection for open-loop vector control 2	Select the carrier frequency when open-loop vector control 2 is used. 1: 2 kHz 2: 4 kHz 3: 6 kHz 4: 8 kHz	1 to 4	4*2	No	No *5	No *5	No *5	No *5	Q	22DH	-
	Carrier Freq Sel											

- * 1. The setting range depends on the control method of the Inverter.
- * 2. The factory setting depends on the capacity of the Inverter.
- * 3. The setting range depends on the capacity of the Inverter.
- * 4. This constant can be monitored or set only when 1 is set for C6-01 and F is set for C6-02.
- * 5. Displayed in Quick Programming Mode when motor 2 is set for a multi-function input.

◆ Reference Constants: d

The following settings are made with the reference constants (d constants): Frequency references.

■ Preset Reference: d1

User constants for frequency references are shown in the following table.

Con-stant Number	Name	Description	Setting Range	Factory Setting	Change during Operation	Control Methods					MEMO BUS Register	Page
	Display					V/f	V/f with PG	Open Loop Vector 1	Flux Vector	Open Loop Vector 2		
d1-01	Frequency reference 1	Sets the frequency reference in the units used in o1-03.	0 to 400.00 *	0.00 Hz	Yes	Q	Q	Q	Q	Q	280H	4-6 6-5
	Reference 1											
d1-02	Frequency reference 2	The frequency reference when multi-step speed reference 1 is ON for a multi-function input.		0.00 Hz	Yes	Q	Q	Q	Q	Q	281H	4-6 6-5
	Reference 2											
d1-03	Frequency reference 3	The frequency reference when multi-step speed reference 2 is ON for a multi-function input.		0.00 Hz	Yes	Q	Q	Q	Q	Q	282H	4-6 6-5
	Reference 3											
d1-04	Frequency reference 4	The frequency reference when multi-step speed references 1 and 2 are ON for multi-function inputs.		0.00 Hz	Yes	Q	Q	Q	Q	Q	283H	4-6 6-5
	Reference 4											
d1-05	Frequency reference 5	The frequency when multi-step speed reference 3 is ON for a multi-function input.		0.00 Hz	Yes	A	A	A	A	A	284H	6-5
	Reference 5											
d1-06	Frequency reference 6	The frequency reference when multi-step speed references 1 and 3 are ON for multi-function inputs.		0.00 Hz	Yes	A	A	A	A	A	285H	6-5
	Reference 6											
d1-07	Frequency reference 7	The frequency reference when multi-step speed references 2 and 3 are ON for multi-function inputs.	0.00 Hz	Yes	A	A	A	A	A	286H	6-5	
	Reference 7											
d1-08	Frequency reference 8	The frequency reference when multi-step speed references 1, 2, and 3 are ON for multi-function inputs.	0.00 Hz	Yes	A	A	A	A	A	287H	6-5	
	Reference 8											
d1-09	Frequency reference 9	The frequency reference when multi-step speed reference 4 is ON for a multi-function input.	0.00 Hz	Yes	A	A	A	A	A	288H	-	
	Reference 9											
d1-10	Frequency reference 10	The frequency reference when multi-step speed references 1 and 4 are ON for multi-function inputs.	0.00 Hz	Yes	A	A	A	A	A	28BH	-	
	Reference 10											
d1-11	Frequency reference 11	The frequency reference when multi-step speed references 2 and 4 are ON for a multi-function inputs.	0.00 Hz	Yes	A	A	A	A	A	28CH	-	
	Reference 11											

Con- stant Number	Name	Description	Setting Range	Factory Setting	Change during Opera- tion	Control Methods					MEMO BUS Regis- ter	Page
	Display					V/f	V/f with PG	Open Loop Vec- tor 1	Flux Vec- tor	Open Loop Vec- tor 2		
d1-12	Frequency reference 12	The frequency reference when multi-step speed refer- ences 1, 2, and 4 are ON for multi-function inputs.	0 to 400.00 *	0.00 Hz	Yes	A	A	A	A	A	28DH	-
	Reference 12											
d1-13	Frequency reference 13	The frequency reference when multi-step speed refer- ences 3 and 4 are ON for multi-function inputs.		0.00 Hz	Yes	A	A	A	A	A	28EH	-
	Reference 13											
d1-14	Frequency reference 14	The frequency reference when multi-step speed refer- ences 1, 3, and 4 are ON for multi-function inputs.		0.00 Hz	Yes	A	A	A	A	A	28FH	-
	Reference 14											
d1-15	Frequency reference 15	The frequency reference when multi-step speed refer- ences 2, 3, and 4 are ON for multi-function inputs.		0.00 Hz	Yes	A	A	A	A	A	290H	-
	Reference 15											
d1-16	Frequency reference 16	The frequency reference when multi-step speed refer- ences 1, 2, 3, and 4 are ON for multi-function inputs.		0.00 Hz	Yes	A	A	A	A	A	291H	-
	Reference 16											
d1-17	Jog frequency reference	The frequency reference when the jog frequency refer- ence selection, FJOG com- mand, or RJOG command is ON.		6.00 Hz	Yes	Q	Q	Q	Q	Q	292H	4-6 6-74
	Jog Reference											

Note The unit is set in o1-03 (frequency units of reference setting and monitor). The default for o1-03 is 0 (increments of 0.01 Hz).

* The setting range is 0 to 66.0 for open-loop vector control 2.

Reference Limits: d2

User constants for frequency reference limits are shown in the following table.

Con- stant Number	Name	Description	Setting Range	Factory Setting	Change during Opera- tion	Control Methods					MEMO BUS Regis- ter	Page
	Display					V/f	V/f with PG	Open Loop Vec- tor 1	Flux Vec- tor	Open Loop Vec- tor 2		
d2-01	Frequency reference upper limit	Set the output frequency upper limit as a percent, tak- ing the max. output frequency to be 100%.	0.0 to 110.0	100.0%	No	A	A	A	A	A	289H	6-30 6-69
	Ref Upper Limit											
d2-02	Frequency reference lower limit	Sets the output frequency lower limit as a percentage of the maximum output fre- quency.	0.0 to 110.0	0.0%	No	A	A	A	A	A	28AH	6-30 6-69
	Ref Lower Limit											
d2-03	Master speed reference lower limit	Set the master speed refer- ence lower limit as a percent, taking the max. output fre- quency to be 100%.	0.0 to 110.0	0.0%	No	A	A	A	A	A	293H	6-30 6-69
	Ref1 Lower Limit											

■ Jump Frequencies: d3

User constants for jump frequencies are shown in the following table.

Constant Number	Name	Description	Setting Range	Factory Setting	Change during Operation	Control Methods					MEMO BUS Register	Page
	Display					V/f	V/f with PG	Open Loop Vector 1	Flux Vector	Open Loop Vector 2		
d3-01	Jump frequency 1	Set the center values of the jump frequencies in Hz. This function is disabled by setting the jump frequency to 0 Hz. Always ensure that the following applies: $d3-01 \geq d3-02 \geq d3-03$	0.0 to 400.0	0.0 Hz	No	A	A	A	A	A	294H	6-27
	Jump Freq 1											
d3-02	Jump frequency 2	Operation in the jump frequency range is prohibited but during acceleration and deceleration, speed changes smoothly without jump.										
	Jump Freq 2											
d3-03	Jump frequency 3											
	Jump Freq 3											
d3-04	Jump frequency width	Sets the jump frequency bandwidth in Hz. The jump frequency will be the jump frequency \pm d3-04.	0.0 to 20.0	1.0 Hz	No	A	A	A	A	A	297H	6-27
	Jump Bandwidth											

■ Reference Frequency Hold: d4

User constants for the reference frequency hold function are shown in the following table.

Constant Number	Name	Description	Setting Range	Factory Setting	Change during Operation	Control Methods					MEMO BUS Register	Page
	Display					V/f	V/f with PG	Open Loop Vector 1	Flux Vector	Open Loop Vector 2		
d4-01	Frequency reference hold function selection	Sets whether or not frequencies on hold will be recorded. 0: Disabled (when operation is stopped or the power is turned on again starts at 0.) 1: Enabled (when operation is stopped or the power is turned on again starts at the previous hold frequency.) This function is available when the multi-function inputs "accel/decel Ramp Hold" or "up/down" commands are set.	0 or 1	0	No	A	A	A	A	A	298H	6-68
	MOP Ref Memory											
d4-02	+ - Speed limits	Set the frequency to be add to or subtracted from the analog frequency reference as a percent, taking the maximum output frequency to be 100%. Enabled when the increase (+) speed command or decrease (-) speed command is set for a multi-function input.	0 to 100	10%	No	A	A	A	A	A	299H	6-72
	Trim Control Lvl											

■ Torque Control: d5

User constants for the torque control are shown in the following table.

Constant Number	Name	Description	Setting Range	Factory Setting	Change during Operation	Control Methods					MEMO BUS Register	Page
	Display					V/f	V/f with PG	Open Loop Vector 1	Flux Vector	Open Loop Vector 2		
d5-01	Torque control selection	0: Speed control (C5-01 to C5-07) 1: Torque control This function is only available in flux vector control mode. To use the function for switching between speed and torque control, set to 0 and set the multi-function input to "speed/torque control change."	0 or 1	0	No	No	No	No	A	A	29AH	-
	Torq Control Sel											
d5-02	Torque reference delay time	Set the torque reference delay time in ms units. This function can be used to adjust the noise of the torque control signal or the responsiveness with the host controller. When oscillation occurs during torque control, increase the set value.	0 to 1000	0 ms*	No	No	No	No	A	A	29BH	-
	Torq Ref Filter											
d5-03	Speed limit selection	Set the speed limit command method for the torque control mode. 1: The analog input limit from a frequency reference 2: Limited by d5-04 constant setting values.	1 or 2	1	No	No	No	No	A	A	29CH	-
	Speed Limit Sel											
d5-04	Speed limit	Set the speed limit during torque control as a percentage of the maximum output frequency. This function is enabled when d5-03 is set to 2. Directions are as follows. +: run command direction -: run command opposite direction	-120 to +120	0%	No	No	No	No	A	A	29DH	-
	Speed Lmt Value											
d5-05	Speed limit bias	Set the speed limit bias as a percentage of the maximum output frequency. Bias is given to the specified speed limit. It can be used to adjust the margin for the speed limit.	0 to 120	10%	No	No	No	No	A	A	29EH	-
	Speed Lmt Bias											

Constant Number	Name	Description	Setting Range	Factory Setting	Change during Operation	Control Methods					MEMO BUS Register	Page
	Display					V/f	V/f with PG	Open Loop Vector 1	Flux Vector	Open Loop Vector 2		
d5-06	Speed/torque control switching timer	Set the delay time from inputting the multi-function input "speed/torque control change" (from On to OFF or OFF to ON) until the control is actually changed, in ms units. This function is enabled when the multi-function input "speed/torque control change" is set. In the speed/torque control switching timer, the analog inputs hold the values of when the "speed/torque control change" changes. Always be sure to allow time for this process to finish completely.	0 to 1000	0 ms	No	No	No	No	A	A	29FH	-
	Ref Hold Time											

* The factory setting will change when the control method is changed.

■Field Control: d6

User constants for the field weakening command are shown in the following table.

Constant Number	Name	Description	Setting Range	Factory Setting	Change during Operation	Control Methods					MEMO BUS Register	Page
	Display					V/f	V/f with PG	Open Loop Vector 1	Flux Vector	Open Loop Vector 2		
d6-01	Field weakening level	Set the Inverter output voltage when the field weakening command is input. It is enabled when the field weakening command is set for a multi-function input. Set the level as a percentage taking the voltage set in the V/f pattern as 100%.	0 to 100	80%	No	A	A	No	No	No	2A0H	-
	Field-Weak Lvl											
d6-02	Field frequency	Set the lower limit in hertz of the frequency range where field control is valid. The field weakening command is valid only at frequencies above this setting and only when the speed is in agreement with the current speed reference.	0.0 to 400.0	0.0 Hz	No	A	A	No	No	No	2A1H	-
	Field-Weak Freq											
d6-03	Field forcing function selection	Set the field forcing function. 0: Disabled 1: Enabled	0 or 1	0	No	No	No	No	A	A	2A2H	-
	Field Force Sel											

Constant Number	Name	Description	Setting Range	Factory Setting	Change during Operation	Control Methods					MEMO BUS Register	Page
	Display					V/f	V/f with PG	Open Loop Vector 1	Flux Vector	Open Loop Vector 2		
d6-05	A ϕ R time constant	Set the factor to multiple times the secondary circuit time constant of the motor to achieve the A ϕ R time constant. A ϕ R time constant = Secondary circuit time constant x d6-05 A ϕ R will not function when d6-05 is 0. If d6-05 is not 0, the lower limit of the value will be internally adjusted to 200 ms in the Inverter.	0.00 to 10.00	1.00	No	No	No	No	No	A	2A4H	-
	A PHI R Filter											

◆ Motor Constant Constants: E

The following settings are made with the motor constant constants (E constants): V/f characteristics and motor constants.

■ V/f Pattern: E1

User constants for V/f characteristics are shown in the following table.

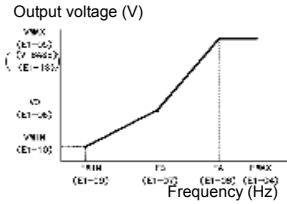
Constant Number	Name Display	Description	Setting Range	Factory Setting	Change during Operation	Control Methods					MEMO-BUS Register	Page
						V/f	V/f with PG	Open Loop Vector 1	Flux Vector	Open Loop Vector 2		
E1-01	Input voltage setting	Set the Inverter input voltage in 1 volt.	155 to 255 *1	200 V *1	No	Q	Q	Q	Q	Q	300H	4-5 6-107
	Input Voltage	This setting is used as a reference value in protection functions.										
E1-03	V/f pattern selection	0 to E: Select from the 15 preset patterns. F: Custom user-set patterns (Applicable for settings E1-04 to E1-10.)	0 to F	F	No	Q	Q	No	No	No	302H	6-107
	V/F Selection											
E1-04	Max. output frequency	 <p>Output voltage (V)</p> <p>Frequency (Hz)</p> <p>FMIN (E1-09) F0 (E1-07) A (E1-06) FMAX (E1-04)</p>	40.0 to 400.0 *5	60.0 Hz *2	No	Q	Q	Q	Q	Q	303H	6-107
	Max Frequency											
E1-05	Max. voltage		0.0 to 255.0 *1	200.0 V *1*2	No	Q	Q	Q	Q	Q	304H	6-107
	Max Voltage											
E1-06	Base frequency		0.0 to 400.0 *5	60.0 Hz *2	No	Q	Q	Q	Q	Q	305H	6-107
	Base Frequency											
E1-07	Mid. output frequency		0.0 to 400.0 *5	3.0 Hz *2	No	A	A	A	No	No	306H	6-107
	Mid Frequency A											
E1-08	Mid. output frequency voltage		0.0 to 255.0 *1	11.0 V *1 *2	No	A	A	A	No	No	307H	4-17 6-107
	Mid Voltage A											
E1-09	Min. output frequency	0.0 to 400.0 *5	0.5 Hz *2	No	Q	Q	Q	A	Q	308H	6-107	
	Min Frequency											
E1-10	Min. output frequency voltage	0.0 to 255.0 *1	2.0 V *1 *2	No	A	A	A	No	No	309H	4-16 4-17 6-107	
	Min Voltage											

Constant Number	Name	Description	Setting Range	Factory Setting	Change during Operation	Control Methods					MEMO-BUS Register	Page
	Display					V/f	V/f with PG	Open Loop Vector 1	Flux Vector	Open Loop Vector 2		
E1-11	Mid. output frequency 2	Set only to fine-adjust V/f for the output range. Normally, this setting is not required.	0.0 to 400.0 *5	0.0 Hz *3	No	A	A	A	A	A	30AH	6-107
	Mid Frequency B											
E1-12	Mid. output voltage 2		0.0 to 255.0 *1	0.0 V *3	No	A	A	A	A	A	30BH	6-107
	Mid Voltage B											
E1-13	Base voltage		0.0 to 255.0 *1	0.0 V *4	No	A	A	Q	Q	Q	30CH	6-107
	Base Voltage											

* 1. These are values for a 200 V Class Inverter. Values for a 400 V Class Inverter are double.

* 2. The factory setting will change when the control method is changed. (Open-loop vector 1 factory settings are given.)

* 3. E1-11 and E1-12 are disregarded when set to 0.0.

* 4. E1-13 is set to the same value as E1-05 by autotuning.

* 5. The setting range is 0 to 66.0 for open-loop vector control 2.

■ Motor Setup: E2

User constants for motor 1 are shown in the following table.

Constant Number	Name	Description	Setting Range	Factory Setting	Change during Operation	Control Methods					MEMO-BUS Register	Page
	Display					V/f	V/f with PG	Open Loop Vector 1	Flux Vector	Open Loop Vector 2		
E2-01	Motor rated current	Sets the motor rated current in 1 A units.	0.32 to 6.40 *2	1.90 A *1	No	Q	Q	Q	Q	Q	30EH	6-49 6-105
	Motor Rated FLA	These set values will become the reference values for motor protection, torque limits and torque control. This constant is automatically set during autotuning.										
E2-02	Motor rated slip	Sets the motor rated slip in Hz units.	0.00 to 20.00	2.90 Hz *1	No	A	A	A	A	A	30FH	6-103 6-105
	Motor Rated Slip	These set values will become the reference values for slip compensation. This constant is automatically set during autotuning.										
E2-03	Motor no-load current	Sets the motor no-load current in 1 A units.	0.00 to 1.89 *3	1.20 A *1	No	A	A	A	A	A	310H	6-105
	No-Load Current	This constant is automatically set during autotuning.										
E2-04	Number of motor poles	Sets the number of motor poles.	2 to 48	4 poles	No	No	Q	No	Q	Q	311H	6-105
	Number of Poles	This constant is automatically set during autotuning.										
E2-05	Motor line-to-line resistance	Sets the motor phase-to-phase resistance in Ω units.	0.000 to 65.000	9.842 Ω *1	No	A	A	A	A	A	312H	6-105
	Term Resistance	This constant is automatically set during autotuning.										

Constant Number	Name	Description	Setting Range	Factory Setting	Change during Operation	Control Methods					MEMO BUS Register	Page
	Display					V/f	V/f with PG	Open Loop Vector 1	Flux Vector	Open Loop Vector 2		
E2-06	Motor leak inductance	Sets the voltage drop due to motor leakage inductance as a percentage of the motor rated voltage. This constant is automatically set during autotuning.	0.0 to 40.0	18.2% *1	No	No	No	A	A	A	313H	6-105
	Leak Inductance											
E2-07	Motor iron saturation coefficient 1	Sets the motor iron saturation coefficient at 50% of magnetic flux. This constant is automatically set during autotuning.	0.00 to 0.50	0.50	No	No	No	A	A	A	314H	6-105
	Saturation Comp1											
E2-08	Motor iron saturation coefficient 2	Sets the motor iron saturation coefficient at 75% of magnetic flux. This constant is automatically set during autotuning.	0.00 to 0.75	0.75	No	No	No	A	A	A	315H	6-105
	Saturation Comp2											
E2-09	Motor mechanical loss	Sets motor mechanical loss as a percentage of motor rated output (W). Usually setting is not necessary. Adjust in the following circumstances: • When torque loss is large due to motor bearing. • When the torque loss in the pump or fan is large. The set mechanical loss will compensate for torque.	0.0 to 10.0	0.0	No	No	No	No	A	A	316H	
	Mechanical Loss											
E2-10	Motor iron loss for torque compensation	Sets motor iron loss in W units.	0 to 65535	14 W *1	No	A	A	No	No	No	317H	6-105
	Temp Iron Loss											
E2-11	Motor rated output	Set the rated output of the motor in units of 0.01 kW. This constant is automatically set during autotuning.	0.00 to 650.00	0.40 *4	No	Q	Q	Q	Q	Q	318H	-
	Mtr Rated Power											

* 1. The factory setting depends upon the Inverter capacity. The value for a 200 V class Inverter of 0.4 kW is given.

* 2. The setting range is 10% to 200% of the Inverter's rated output current. The value for a 200 V class Inverter of 0.4 kW is given.

* 3. The factory setting depends upon the Inverter capacity. The value for a 200 V class Inverter of 0.4 kW is given.

* 4. The same capacity as the Inverter will be set by initializing the constants.

■ Motor 2 V/f Pattern: E3

User constants for motor 2 V/f characteristics are shown in the following table.

Constant Number	Name	Description	Setting Range	Factory Setting	Change during Operation	Control Methods					MEMO-BUS Register	Page
	Display					V/f	V/f with PG	Open Loop Vector 1	Flux Vector	Open Loop Vector 2		
E3-01	Motor 2 control method selection	0: V/f control 1: V/f control with PG 2: Open-loop vector control 3: Flux vector control 4: Open-loop vector control 2	0 to 4	2	No	A	A	A	A	A	319H	-
	Control Method											

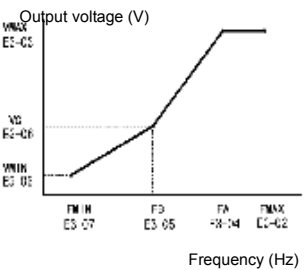
Constant Number	Name	Description	Setting Range	Factory Setting	Change during Operation	Control Methods					MEMO-BUS Register	Page
	Display					V/f	V/f with PG	Open Loop Vector 1	Flux Vector	Open Loop Vector 2		
E3-02	Motor 2 max. output frequency (FMAX)	 <p>To set V/f characteristics in a straight line, set the same values for E3-05 and E3-07. In this case, the setting for E3-06 will be disregarded. Always ensure that the four frequencies are set in the following manner: E3-02 (FMAX) ≥ E3-04 (FA) > E3-05 (FB) > E3-07 (FMIN)</p>	40.0 to 400.0 *3	60.0 Hz	No	A	A	A	A	A	31AH	-
	Max Frequency											
E3-03	Motor 2 max. voltage (VMAX)		0.0 to 255.0 *1	200.0 V *2	No	A	A	A	A	A	31BH	-
	Max Voltage											
E3-04	Motor 2 max. voltage frequency (FA)		0.0 to 400.0 Hz	60.0 Hz	No	A	A	A	A	A	31CH	-
	Base Frequency											
E3-05	Motor 2 mid. output frequency 1 (FB)		0.0 to 400.0	3.0 Hz *2	No	A	A	A	No	No	31DH	-
	Mid Frequency											
E3-06	Motor 2 mid. output frequency voltage 1 (VC)	0.0 to 255.0 *1	11.0 V *1	No	A	A	A	No	No	31EH	-	
	Mid Voltage											
E3-07	Motor 2 min. output frequency (FMIN)	0.0 to 400.0	0.5 Hz *2	No	A	A	A	A	A	31FH	-	
	Min Frequency											
E3-08	Motor 2 min. output frequency voltage (VMIN)	0.0 to 255.0 *1	2.0 V *1	No	A	A	A	No	No	320H	-	
	Min Voltage											

* 1. These are values for a 200 V class Inverter. Values for a 400 V class Inverter are double.
* 2. The factory setting will change when the control method is changed. (V/f control factory settings are given.)
* 3. The setting range is 0 to 66.0 for open-loop vector control 2.

Motor 2 Setup: E4

User constants for motor 2 are shown in the following table.

Constant Number	Name	Description	Setting Range	Factory Setting	Change during Operation	Control Methods					MEMO BUS Register	Page
	Display					V/f	V/f with PG	Open Loop Vector 1	Flux Vector	Open Loop Vector 2		
E4-01	Motor 2 rated current	Sets the motor rated current in 1 A units.	0.32 to 6.40 *2	1.90 A *1	No	A	A	A	A	A	321H	6-49
	Motor Rated FLA	These set values will become the reference values for motor protection, torque limits and torque control. This constant is automatically set during autotuning.										
E4-02	Motor 2 rated slip	Sets the motor rated slip in Hz units.	0.00 to 20.00	2.90 Hz *1	No	A	A	A	A	A	322H	-
	Motor Rated Slip	These set values will become the reference values for slip compensation. This constant is automatically set during autotuning.										
E4-03	Motor 2 no-load current	Sets the motor no-load current in 1 A units.	0.00 to 1.89 *3	1.20 A *1	No	A	A	A	A	A	323H	-
	No-Load Current	This constant is automatically set during autotuning.										
E4-04	Motor 2 number of poles (number of poles)	Sets the number of motor poles. This constant is automatically set during autotuning.	2 to 48	4 poles	No	No	A	No	A	A	324H	-
	Number of Poles											
E4-05	Motor 2 line-to-line resistance	Sets the motor phase-to-phase resistance in Ω units. This constant is automatically set during autotuning.	0.000 to 65.000	9.842 Ω *1	No	A	A	A	A	A	325H	-
	Term Resistance											
E4-06	Motor 2 leak inductance	Sets the voltage drop due to motor leakage inductance as a percentage of the motor rated voltage. This constant is automatically set during autotuning.	0.0 to 40.0	18.2% *1	No	No	No	A	A	A	326H	-
	Leak Inductance											
E4-07	Motor 2 rated capacity	Set the rated output of the motor in units of 0.01 kW. This constant is automatically set during autotuning.	0.00 to 650.00	0.40 *4	No	A	A	A	A	A	327H	-
	Mtr Rated Power											

* 1. The factory setting depends upon the Inverter capacity. The value for a 200 V class Inverter of 0.4 kW is given.

* 2. The setting range is 10% to 200% of the Inverter's rated output current. The values for a 200 V class Inverter of 0.4 kW is given.

* 3. If a multi-function input is set for motor 2 (H1-□□ = 16), the factory setting will depend upon the Inverter capacity. The value for a 200 V class Inverter of 0.4 kW is given.

* 4. The same capacity as the Inverter will be set by initializing the constants.

◆ Option Constants: F

The following settings are made with the option constants (F constants): Settings for Option Cards

■ PG Option Setup: F1

User constants for the PG Speed Control Card are shown in the following table.

Con-stant Number	Name		Description	Setting Range	Factory Setting	Change during Operation	Control Methods					MEMO BUS Register	Page
	Display						V/f	V/f with PG	Open Loop Vector 1	Flux Vector	Open Loop Vector 2		
F1-01	PG constant		Sets the number of PG (pulse generator or encoder) pulses. Sets the number of pulses per motor revolution.	0 to 60000	600	No	No	Q	No	Q	No	380H	6-142
	PG Pulses/Rev												
F1-02	Operation selection at PG open circuit (PGO)		Sets the PG disconnection stopping method. 0: Ramp to stop (Deceleration stop using Deceleration Time 1, C1-02.) 1: Coast to stop 2: Fast stop (Emergency stop using the deceleration time in C1-09.) 3: Continue operation (To protect the motor or machinery, do not normally make this setting.)	0 to 3	1	No	No	A	No	A	No	381H	6-142
	PG Fdbk Loss Sel												
F1-03	Operation selection at overspeed (OS)		Sets the stopping method when an overspeed (OS) fault occurs. 0: Ramp to stop (Deceleration stop using Deceleration Time 1, C1-02.) 1: Coast to stop 2: Fast stop (Emergency stop using the deceleration time in C1-09.) 3: Continue operation (To protect the motor or machinery, do not normally make this setting.)	0 to 3	1	No	No	A	No	A	A	382H	6-142
	PG Over-speed Sel												
F1-04	Operation selection at deviation		Sets the stopping method when a speed deviation (DEV) fault occurs. 0: Ramp to stop (Deceleration stop using Deceleration Time 1, C1-02.) 1: Coast to stop 2: Fast stop (Emergency stop using the deceleration time in C1-09.) 3: Continue operation (DEV is displayed and operation continued.)	0 to 3	3	No	No	A	No	A	A	383H	6-142
	PG Deviation Sel												

Constant Number	Name	Description	Setting Range	Factory Setting	Change during Operation	Control Methods					MEMO BUS Register	Page
	Display					V/f	V/f with PG	Open Loop Vector 1	Flux Vector	Open Loop Vector 2		
F1-05	PG rotation	0: Phase A leads with forward run command. (Phase B leads with reverse run command.) 1: Phase B leads with forward run command. (Phase A leads with reverse run command.)	0 or 1	0	No	No	A	No	A	No	384H	6-142
	PG Rotation Sel											
F1-06	PG division rate (PG pulse monitor)	Sets the division ratio for the PG speed control card pulse output. Division ratio = $(1+n)/m$ ($n=0$ or 1 $m=1$ to 32) F1-06 = $\frac{\square}{n} \frac{\square}{m}$ This constant is only effective when a PG-B2 is used. The possible division ratio settings are: $1/32 \leq F1-06 \leq 1$.	1 to 132	1	No	No	A	No	A	No	385H	6-143
	PG Output Ratio											
F1-07	Integral value during accel/ decel enable/disable	Sets integral control during acceleration/deceleration to either enabled or disabled. 0: Disabled (The integral function isn't used while accelerating or decelerating; it is used at constant speeds.) 1: Enabled (The integral function is used at all times.)	0 or 1	0	No	No	A	No	No	No	386H	6-143
	PG Ramp PI/Sel											
F1-08	Overspeed detection level	Sets the overspeed detection method. Frequencies above that set for F1-08 (set as a percentage of the maximum output frequency) that continue to exceed this frequency for the time set in F1-09 are detected as overspeed faults.	0 to 120	115%	No	No	A	No	A	A	387H	6-143
	PG Overspd Level											
F1-09	Overspeed detection delay time		0.0 to 2.0	0.0 s*	No	No	A	No	A	A	388H	6-143
	PG Overspd Time											
F1-10	Excessive speed deviation detection level	Sets the speed deviation detection method. Any speed deviation above the F1-10 set level (set as a percentage of the maximum output frequency) that continues for the time set in F1-11 is detected as a speed deviation. Speed deviation is the difference between actual motor speed and the reference command speed.	0 to 50	10%	No	No	A	No	A	A	389H	6-143
	PG Deviate Level											
F1-11	Excessive speed deviation detection delay time		0.0 to 10.0	0.5 s	No	No	A	No	A	A	38AH	6-143
	PG Deviate Time											

* The factory setting will change when the control method is changed. (Flux vector control factory settings are given.)

Constant Number	Name	Description	Setting Range	Factory Setting	Change during Operation	Control Methods					MEMO BUS Register	Page
	Display					V/f	V/f with PG	Open Loop Vector 1	Flux Vector	Open Loop Vector 2		
F1-12	Number of PG gear teeth 1	Sets the number of teeth on the gears if there are gears between the PG and the motor. $\frac{\text{Input pulses from PG} \times 60}{\text{F1-01}} \times \frac{\text{F1-13}}{\text{F1-12}}$	0 to 1000	0	No	No	A	No	No	No	38BH	6-143
	PG # Gear Teeth1											
F1-13	Number of PG gear teeth 2	A gear ratio of 1 will be used if either of these constants is set to 0.	0 to 1000	0	No	No	A	No	No	No	38CH	6-143
	PG # Gear Teeth2											
F1-14	PG open-circuit detection time	Used to set the PG disconnection detection time. PGO will be detected if the detection time continues beyond the set time.	0.0 to 10.0	2.0 s	No	No	A	No	A	No	38DH	6-143
	PGO Detect Time											

■ Analog Reference Card: F2

User constants for the Analog Reference Card are shown in the following table.

Constant Number	Name	Description	Setting Range	Factory Setting	Change during Operation	Control Methods					MEMO BUS Register	Page
	Display					V/f	V/f with PG	Open Loop Vector 1	Flux Vector	Open Loop Vector 2		
F2-01	Bi-polar or uni-polar input selection	Sets the functions for channel 1 to 3 which are effective when the AI-14B Analog Reference Card is used. 0: 3-channel individual (Channel 1: terminal A1, Channel 2: terminal A2, Channel 3: terminal A3) 1: 3-channel addition (Addition values are the frequency reference) When set to 0, select 1 for b1-01. In this case the multi-function input "Option/ Inverter selection" cannot be used.	0 or 1	0	No	A	A	A	A	A	38FH	6-149
	AI-14 Input Sel											

■ Digital Reference Card: F3

User constants for the Digital Reference Card are shown in the following table.

Constant Number	Name	Description	Setting Range	Factory Setting	Change during Operation	Control Methods					MEMO BUS Register	Page
	Display					V/f	V/f with PG	Open Loop Vector 1	Flux Vector	Open Loop Vector 2		
F3-01	Digital input option	Sets the Digital Reference Card input method. 0: BCD 1% unit 1: BCD 0.1% unit 2: BCD 0.01% unit 3: BCD 1 Hz unit 4: BCD 0.1 Hz unit 5: BCD 0.01 Hz unit 6: BCD special setting (5-digit input) 7: Binary input 6 is only effective when the DI-16H2 is used. When o1-03 is set to 2 or higher, the input will be BCD, and the units will change to the o1-03 setting.	0 to 7	0	No	A	A	A	A	A	390H	6-149
	DI Input											

■ Analog Monitor Cards: F4

User constants for the Analog Monitor Card are shown in the following table.

Constant Number	Name	Description	Setting Range	Factory Setting	Change during Operation	Control Methods					MEMO BUS Register	Page
	Display					V/f	V/f with PG	Open Loop Vector 1	Flux Vector	Open Loop Vector 2		
F4-01	Channel 1 monitor selection	Effective when the Analog Monitor Card is used. Monitor selection: Set the number of the monitor item to be output. (U1-□□) Gain:	1 to 45	2	No	A	A	A	A	A	391H	6-77
	AO Ch1 Select											
F4-02	Channel 1 gain	Set the multiple of 10 V for outputting monitor items. 4, 10 to 14, 25, 28, 34, 39, 40 cannot be set. 29 to 31 and 41 are not used. When the AO-12 Analog Monitor Card is used, outputs of ± 10 V are possible. To output ± 10 V, set F4-07 or F4-08 to 1. When the AO-08 Analog Monitor Card is used, only outputs of 0 to +10 V are possible. A meter calibration function is available.	0.00 to 2.50	1.00	Yes	A	A	A	A	A	392H	6-77
	AO Ch1 Gain											
F4-03	Channel 2 monitor selection	Sets the channel 1 item bias to 100%/10 V when the analog monitor card is used.	1 to 45	3	No	A	A	A	A	A	393H	6-77
	AO Ch2 Select											
F4-04	Channel 2 gain	Sets the channel 2 item bias to 100%/10 V when the analog monitor card is used.	0.00 to 2.50	0.50	Yes	A	A	A	A	A	394H	6-77
	AO Ch2 Gain											
F4-05	Channel 1 output monitor bias	Sets the channel 1 item bias to 100%/10 V when the analog monitor card is used.	-10.0 to 10.0	0.0%	Yes	A	A	A	A	A	395H	6-77
	AO Ch1 Bias											
F4-06	Channel 2 output monitor bias	Sets the channel 2 item bias to 100%/10 V when the analog monitor card is used.	-10.0 to 10.0	0.0%	Yes	A	A	A	A	A	396H	6-77
	AO Ch2 Bias											
F4-07	Analog output signal level for channel 1	0: 0 to 10 V 1: -10 to +10 V	0 or 1	0	No	A	A	A	A	A	397H	-
	AO Opt Level Sel											
F4-08	Analog output signal level for channel 2	0: 0 to 10 V 1: -10 to +10 V	0 or 1	0	No	A	A	A	A	A	398H	6-77
	AO Opt Level Sel											

■ Digital Output Card (DO-02 and DO-08): F5

User constants for the Digital Output Card are shown in the following table.

Constant Number	Name	Description	Setting Range	Factory Setting	Change during Operation	Control Methods					MEMO BUS Register	Page
	Display					V/f	V/f with PG	Open Loop Vector 1	Flux Vector	Open Loop Vector 2		
F5-01	Channel 1 output selection	Effective when a Digital Output Card (DO-02 or DO-08) is used.	0 to 37	0	No	A	A	A	A	A	399H	6-146
	DO Ch1 Select	Set the number of the multi-function output to be output.										
F5-02	Channel 2 output selection	Effective when a Digital Output Card (DO-02 or DO-08) is used.	0 to 37	1	No	A	A	A	A	A	39AH	6-146
	DO Ch2 Select	Set the number of the multi-function output to be output.										
F5-03	Channel 3 output selection	Effective when a DO-08 Digital Output Card is used.	0 to 37	2	No	A	A	A	A	A	39BH	6-146
	DO Ch3 Select	Set the number of the multi-function output to be output.										
F5-04	Channel 4 output selection	Effective when a DO-08 Digital Output Card is used.	0 to 37	4	No	A	A	A	A	A	39CH	6-146
	DO Ch4 Select	Set the number of the multi-function output to be output.										
F5-05	Channel 5 output selection	Effective when a DO-08 Digital Output Card is used.	0 to 37	6	No	A	A	A	A	A	39DH	6-146
	DO Ch5 Select	Set the number of the multi-function output to be output.										
F5-06	Channel 6 output selection	Effective when a DO-08 Digital Output Card is used.	0 to 37	37	No	A	A	A	A	A	39EH	6-147
	DO Ch6 Select	Set the number of the multi-function output to be output.										
F5-07	Channel 7 output selection	Effective when a DO-08 Digital Output Card is used.	0 to 37	0F	No	A	A	A	A	A	39FH	6-147
	DO Ch7 Select	Set the number of the multi-function output to be output.										
F5-08	Channel 8 output selection	Effective when a DO-08 Digital Output Card is used.	0 to 37	0F	No	A	A	A	A	A	3A0H	6-147
	DO Ch8 Select	Set the number of the multi-function output to be output.										
F5-09	DO-08 output mode selection	Effective when a DO-08 Digital Output Card is used. Set the output mode.	0 to 2	0	No	A	A	A	A	A	3A1H	6-147
	DO-08 Selection	0: 8-channel individual outputs 1: Binary code output 2: Output according to F5-01 to F5-08 settings.										

■ Communications Option Cards: F6

User constants for a Communications Option Card are shown in the following table.

Constant Number	Name	Description	Setting Range	Factory Setting	Change during Operation	Control Methods					MEMO BUS Register	Page
	Display					V/f	V/f with PG	Open Loop Vector 1	Flux Vector	Open Loop Vector 2		
F6-01	Operation selection after communications error	Set the stopping method for communications errors. 0: Deceleration stop using deceleration time in C1-02 1: Coast to stop 2: Emergency stop using deceleration time in C1-09 3: Continue operation	0 to 3	1	No	A	A	A	A	A	3A2H	-
	BUS Fault Sel											
F6-02	Input level of external fault from Communications Option Card	0: Always detect 1: Detect during operation	0 or 1	0	No	A	A	A	A	A	3A3H	-
	EF0 Detection											
F6-03	Stopping method for external fault from Communications Option Card	0: Deceleration stop using deceleration time in C1-02 1: Coast to stop 2: Emergency stop using deceleration time in C1-09 3: Continue operation	0 to 3	1	No	A	A	A	A	A	3A4H	-
	EF0 Fault Action											
F6-04	Trace sampling from Communications Option Card	-	0 to 60000	0	No	A	A	A	A	A	3A5H	-
	Trace Sample Tim											
F6-06	Torque reference/torque limit selection from optical option	0: Torque reference/torque limit from transmission disabled. 1: Torque reference/torque limit from transmission enabled.	0 or 1	1	No	No	No	No	A	A	3A7H	-
	Torq Ref/Lmt Sel											

◆ Terminal Function Constants: H

The following settings are made with the terminal function constants (H constants): Settings for external terminal functions.

■ Multi-function Contact Inputs: H1

User constants for multi-function contact inputs are shown in the following tables.

Con- stant Number	Name	Description	Setting Range	Factory Setting	Change during Opera- tion	Control Methods					MEMO BUS Regis- ter	Page
	Display					V/f	V/f with PG	Open Loop Vec- tor 1	Flux Vec- tor	Open Loop Vec- tor 2		
H1-01	Terminal S3 function selec- tion	Multi-function contact input 1	0 to 78	24	No	A	A	A	A	A	400H	-
	Terminal S3 Sel											
H1-02	Terminal S4 function selec- tion	Multi-function contact input 2	0 to 78	14	No	A	A	A	A	A	401H	-
	Terminal S4 Sel											
H1-03	Terminal S5 function selec- tion	Multi-function contact input 3	0 to 78	3 (0)*	No	A	A	A	A	A	402H	-
	Terminal S5 Sel											
H1-04	Terminal S6 function selec- tion	Multi-function contact input 4	0 to 78	4 (3)*	No	A	A	A	A	A	403H	-
	Terminal S6 Sel											
H1-05	Terminal S7 function selec- tion	Multi-function contact input 5	0 to 78	6 (4)*	No	A	A	A	A	A	404H	-
	Terminal S7 Sel											
H1-06	Terminal S8 function selec- tion	Multi-function contact input 6	0 to 78	8 (6)	No	A	A	A	A	A	405H	-
	Terminal S8 Sel											
H1-07	Terminal S9 function selec- tion	Multi-function contact input 7	0 to 78	5	No	A	A	A	A	A	406H	-
	Terminal S9 Sel											
H1-08	Terminal S10 function selec- tion	Multi-function contact input 8	0 to 78	32	No	A	A	A	A	A	407H	-
	Terminal S10 Sel											

Constant Number	Name	Description	Setting Range	Factory Setting	Change during Operation	Control Methods					MEMO BUS Register	Page
	Display					V/f	V/f with PG	Open Loop Vector 1	Flux Vector	Open Loop Vector 2		
H1-09	Terminal S11 function selection	Multi-function contact input 9	0 to 78	7	No	A	A	A	A	A	408H	-
	Terminal S11 Sel											
H1-10	Terminal S12 function selection	Multi-function contact input 10	0 to 78	15	No	A	A	A	A	A	409H	-
	Terminal S12 Sel											

* The values in parentheses indicate initial values when initialized in 3-wire sequence.

Multi-function Contact Input Functions

Setting Value	Function	Control Methods					Page
		V/f	V/f with PG	Open Loop Vector 1	Flux Vector	Open Loop Vector 2	
0	3-wire sequence (Forward/Reverse Run command)	Yes	Yes	Yes	Yes	Yes	6-8
1	Local/Remote selection (ON: Operator, OFF: Constant setting)	Yes	Yes	Yes	Yes	Yes	6-66
2	Option/Inverter selection (ON: Option Card)	Yes	Yes	Yes	Yes	Yes	6-73
3	Multi-step speed reference 1 When H3-05 is set to 2, this function is combined with the master/auxiliary speed switch.	Yes	Yes	Yes	Yes	Yes	6-5
4	Multi-step speed reference 2	Yes	Yes	Yes	Yes	Yes	6-5
5	Multi-step speed reference 3	Yes	Yes	Yes	Yes	Yes	6-5
6	Jog frequency command (higher priority than multi-step speed reference)	Yes	Yes	Yes	Yes	Yes	6-5
7	Accel/decel time 1	Yes	Yes	Yes	Yes	Yes	6-16
8	External baseblock NO (NO contact: Baseblock at ON)	Yes	Yes	Yes	Yes	Yes	6-67
9	External baseblock NC (NC contact: Baseblock at OFF)	Yes	Yes	Yes	Yes	Yes	6-67
A	Acceleration/deceleration ramp hold (ON: Acceleration/deceleration stopped, frequency on hold)	Yes	Yes	Yes	Yes	Yes	6-68
B	OH2 alarm signal input (ON: OH2 will be displayed)	Yes	Yes	Yes	Yes	Yes	-
C	Multi-function analog input selection (ON: Enable)	Yes	Yes	Yes	Yes	Yes	-
D	No V/f control with PG (ON: Speed feedback control disabled,) (normal V/f control)	No	Yes	No	No	No	-
E	Speed control integral reset (ON: Integral control disabled)	No	Yes	No	Yes	Yes	-
F	Not used (Set when a terminal is not used)	-	-	-	-	-	-
10	Up command (Always set with the down command)	Yes	Yes	Yes	Yes	Yes	6-69
11	Down command (Always set with the up command)	Yes	Yes	Yes	Yes	Yes	6-69
12	FJOG command (ON: Forward run at jog frequency d1-17)	Yes	Yes	Yes	Yes	Yes	6-74
13	RJOG command (ON: Reverse run at jog frequency d1-17)	Yes	Yes	Yes	Yes	Yes	6-74
14	Fault reset (Reset when turned ON)	Yes	Yes	Yes	Yes	Yes	7-2
15	Emergency stop. (Normally open condition: Deceleration to stop in deceleration time set in C1-09 when ON.)	Yes	Yes	Yes	Yes	Yes	6-14
16	Motor switch command (Motor 2 selection)	Yes	Yes	Yes	Yes	Yes	-

Setting Value	Function	Control Methods					Page
		V/f	V/f with PG	Open Loop Vector 1	Flux Vector	Open Loop Vector 2	
17	Emergency stop (Normally closed condition: Deceleration to stop in deceleration time set in C1-09 when OFF)	Yes	Yes	Yes	Yes	Yes	6-14
18	Timer function input (Functions are set in b4-01 and b4-02 and the timer function outputs are set in H1-□□ and H2-□□.)	Yes	Yes	Yes	Yes	Yes	6-93
19	PID control disable (ON: PID control disabled)	Yes	Yes	Yes	Yes	Yes	6-97
1A	Accel/Decel time 2	Yes	Yes	Yes	Yes	Yes	6-16
1B	Constants write enable (ON: All constants can be written-in. OFF: All constants other than frequency monitor are write protected.)	Yes	Yes	Yes	Yes	Yes	6-139
1C	Trim control increase (ON: d4-02 frequency is added to analog frequency reference.)	Yes	Yes	Yes	Yes	Yes	6-72
1D	Trim control decrease (ON: d4-02 frequency is subtracted from analog frequency reference.)	Yes	Yes	Yes	Yes	Yes	6-72
1E	Analog frequency reference sample/hold	Yes	Yes	Yes	Yes	Yes	6-73
20 to 2F	External fault (Desired settings possible) Input mode: NO contact/NC contact, Detection mode: Normal/during operation	Yes	Yes	Yes	Yes	Yes	6-75
30	PID control integral reset (reset when reset command is input or when stopped during PID control)	Yes	Yes	Yes	Yes	Yes	6-97
31	PID control integral hold (ON: Hold)	Yes	Yes	Yes	Yes	Yes	6-97
32	Multi-step speed reference 4	Yes	Yes	Yes	Yes	Yes	-
34	PID soft starter	Yes	Yes	Yes	Yes	Yes	6-97
35	PID input characteristics switch	Yes	Yes	Yes	Yes	Yes	6-97
60	DC injection braking command (ON: Performs DC injection braking)	Yes	Yes	Yes	Yes	Yes	6-13
61	External search command 1 (ON: Speed search from maximum output frequency)	Yes	No	Yes	No	Yes	6-57
62	External search command 2 (ON: Speed search from set frequency)	Yes	No	Yes	No	Yes	6-57
63	Field weakening command (ON: Field weakening control set for d6-01 and d6-02)	Yes	Yes	No	No	No	-
64	External speed search command 3	Yes	Yes	Yes	Yes	Yes	-
65	KEB (deceleration at momentary power loss) command (NO contact)	Yes	Yes	Yes	Yes	Yes	-
66	KEB (deceleration at momentary power loss) command (NO contact)	Yes	Yes	Yes	Yes	Yes	-
67	Communications test mode ("Pass" is displayed when the communications test is passed.)	Yes	Yes	Yes	Yes	Yes	6-92
68	High-slip braking (HSB)	Yes	Yes	No	No	No	-
71	Speed/torque control change (ON: Torque control)	No	No	No	Yes	Yes	-
72	Zero-servo command (ON: Zero-servo)	No	No	No	Yes	No	-
77	Speed control (ASR) proportional gain switch (ON: C5-03)	No	No	No	Yes	Yes	-
78	Polarity reversing command for external torque reference	No	No	No	Yes	Yes	-

■ Multi-function Contact Outputs: H2

User constants for multi-function outputs are shown in the following tables.

Constant Number	Name	Description	Setting Range	Factory Setting	Change during Operation	Control Methods					MEMO BUS Register	Page
	Display					V/f	V/f with PG	Open Loop Vector 1	Flux Vector	Open Loop Vector 2		
H2-01	Terminal M1-M2 function selection (contact)	Multi-function contact output	0 to 37	0	No	A	A	A	A	A	40BH	-
	Term M1-M2 Sel											
H2-02	Terminal M3-M4 function selection (open collector)	Multi-function contact output 1	0 to 37	1	No	A	A	A	A	A	40CH	-
	Term M3-M4 Sel											
H2-03	Terminal M5-M6 function selection (open collector)	Multi-function contact output 2	0 to 37	2	No	A	A	A	A	A	40DH	-
	Term M5-M6 Sel											
H2-04	Terminal P3 function selection (open collector)	Multi-function contact output 3	0 to 37	6	No	A	A	A	A	A	40EH	-
	Term P3 Sel											
H2-05	Terminal P4 function selection (open collector)	Multi-function contact output 4	0 to 37	10	No	A	A	A	A	A	40FH	-
	Term P4 Sel											

Multi-function Contact Output Functions

Setting Value	Function	Control Methods					Page
		V/f	V/f with PG	Open Loop Vector 1	Flux Vector	Open Loop Vector 2	
0	During run (ON: run command is ON or voltage is being output)	Yes	Yes	Yes	Yes	Yes	-
1	Zero-speed	Yes	Yes	Yes	Yes	Yes	-
2	Frequency agree 1 (L4-02 used.)	Yes	Yes	Yes	Yes	Yes	-
3	Desired frequency agree 1 (ON: Output frequency = \pm L4-01, L4-02 used and during frequency agree)	Yes	Yes	Yes	Yes	Yes	-
4	Frequency (FOUT) detection 1 (ON: +L4-01 \geq output frequency \geq -L4-01, L4-02 used)	Yes	Yes	Yes	Yes	Yes	-
5	Frequency (FOUT) detection 2 (ON: Output frequency \geq +L4-01 or output frequency \leq -L4-01, L4-02 used)	Yes	Yes	Yes	Yes	Yes	-
6	Inverter operation ready READY: After initialization, no faults	Yes	Yes	Yes	Yes	Yes	-
7	During DC bus undervoltage (UV) detection	Yes	Yes	Yes	Yes	Yes	-
8	During baseblock (ON: during baseblock)	Yes	Yes	Yes	Yes	Yes	-
9	Frequency reference selection (ON: Frequency reference from Operator)	Yes	Yes	Yes	Yes	Yes	-
A	Run command selection status (ON: Run command from Operator)	Yes	Yes	Yes	Yes	Yes	-
B	Overtorque/undertorque detection 1 NO (NO contact: Overtorque/undertorque detection at ON)	Yes	Yes	Yes	Yes	Yes	6-46
C	Loss of frequency reference (Effective when 1 is set for L4-05)	Yes	Yes	Yes	Yes	Yes	6-62
D	Braking resistor fault (ON: Resistor overheat or braking transistor fault)	Yes	Yes	Yes	Yes	Yes	6-64
E	Fault (ON: Digital Operator communications error or fault other than CPF00 and CPF01 has occurred.)	Yes	Yes	Yes	Yes	Yes	-
F	Not used. (Set when the terminals are not used.)	-	-	-	-	-	-
10	Minor fault (ON: Alarm displayed)	Yes	Yes	Yes	Yes	Yes	-
11	Fault reset command active	Yes	Yes	Yes	Yes	Yes	-
12	Timer function output	Yes	Yes	Yes	Yes	Yes	6-93
13	Frequency agree 2 (L4-04 used)	Yes	Yes	Yes	Yes	Yes	-
14	Desired frequency agree 2 (ON: Output frequency = L4-03, L4-04 used, and during frequency agree)	Yes	Yes	Yes	Yes	Yes	-
15	Frequency detection 3 (ON: Output frequency \leq -L4-03, L4-04 used)	Yes	Yes	Yes	Yes	Yes	-
16	Frequency detection 4 (ON: Output frequency \geq -L4-03, L4-04 used)	Yes	Yes	Yes	Yes	Yes	-
17	Overtorque/undertorque detection 1 NC (NC Contact: Torque detection at OFF)	Yes	Yes	Yes	Yes	Yes	6-46
18	Overtorque/undertorque detection 2 NO (NO Contact: Torque detection at ON)	Yes	Yes	Yes	Yes	Yes	6-46
19	Overtorque/undertorque detection 2 NC (NC Contact: Torque detection at OFF)	Yes	Yes	Yes	Yes	Yes	6-46
1A	During reverse run (ON: During reverse run)	Yes	Yes	Yes	Yes	Yes	-
1B	During baseblock 2 (OFF: During baseblock)	Yes	Yes	Yes	Yes	Yes	-
1C	Motor selection (Motor 2 selected)	Yes	Yes	Yes	Yes	Yes	-
1D	During regenerative operation (ON: During regenerative operation)	No	No	No	Yes	Yes	-
1E	Restart enabled (ON: Restart enabled)	Yes	Yes	Yes	Yes	Yes	6-63
1F	Motor overload (OL1, including OH3) pre-alarm (ON: 90% or more of the detection level)	Yes	Yes	Yes	Yes	Yes	6-49
20	Inverter overheat (OH) pre-alarm (ON: Temperature exceeds L8-02 setting)	Yes	Yes	Yes	Yes	Yes	-
30	During torque limit (current limit) (ON: During torque limit)	No	No	Yes	Yes	Yes	-

Setting Value	Function	Control Methods					Page
		V/f	V/f with PG	Open Loop Vector 1	Flux Vector	Open Loop Vector 2	
31	During speed limit (ON: During speed limit)	No	No	No	Yes	Yes	-
32	Speed control circuit operating for torque control (except when stopped). The external torque reference will be limited if torque control is selected (internal torque reference < external torque reference). Output when the motor is rotating at the speed limit.	No	No	No	Yes	Yes	6-116
33	Zero-servo end (ON: Zero-servo function completed)	No	No	No	Yes	No	-
37	During run 2 (ON: Frequency output, OFF: Base block, DC injection braking, initial excitation, operation stop)	Yes	Yes	Yes	Yes	Yes	-

■ Analog Inputs: H3

User constants for analog inputs are shown in the following table.

Constant Number	Name	Description	Setting Range	Factory Setting	Change during Operation	Control Methods					MEMO BUS Register	Page
	Display					V/f	V/f with PG	Open Loop Vector 1	Flux Vector	Open Loop Vector 2		
H3-01	Signal level selection (terminal A1)	0: 0 to ±10V [11-bit + polarity (positive/negative) input] 1: 0 to ±10V	0 or 1	0	No	A	A	A	A	A	410H	6-24
	Term A1 Signal											
H3-02	Gain (terminal A1)	Sets the frequency when 10 V is input, as a percentage of the maximum output frequency.	0.0 to 1000.0	100.0%	Yes	A	A	A	A	A	411H	6-24
	Terminal A1 Gain											
H3-03	Bias (terminal A1)	Sets the frequency when 0 V is input, as a percentage of the maximum frequency.	-100.0 to +100.0	0.0%	Yes	A	A	A	A	A	412H	6-24
	Terminal A1 Bias											
H3-04	Signal level selection (terminal A3)	0: 0 to ±10V [11-bit + polarity (positive/negative) input] 1: 0 to ±10V	0 or 1	0	No	A	A	A	A	A	413H	6-24
	Term A3 Signal											
H3-05	Multi-function analog input (terminal A3)	Select from the functions listed in the following table. Refer to the next page.	0 to 1F	2	No	A	A	A	A	A	414H	6-24
	Terminal A3 Sel											
H3-06	Gain (terminal A3)	Sets the input gain (level) when terminal 16 is 10V. Set according to the 100% value selected from H3-05.	0.0 to 1000.0	100.0%	Yes	A	A	A	A	A	415H	6-24
	Terminal A3 Gain											
H3-07	Bias (terminal A3)	Sets the input gain (level) when terminal 16 is 10V. Set according to the 100% value selected from H3-05.	-100.0 to +100.0	0.0%	Yes	A	A	A	A	A	416H	6-24
	Terminal A3 Bias											

Constant Number	Name	Description	Setting Range	Factory Setting	Change during Operation	Control Methods					MEMO BUS Register	Page
	Display					V/f	V/f with PG	Open Loop Vector 1	Flux Vector	Open Loop Vector 2		
H3-08	Multi-function analog input terminal A2 signal level selection	0: Limit negative frequency settings for gain and bias settings to 0. 1: Do not limit negative frequency settings for gain and bias settings to 0 (i.e., allow reverse operation). 2: 4 to 20 mA (9-bit input). Switch current and voltage input using the switch on the control panel.	0 to 2	2	No	A	A	A	A	A	417H	6-24
	Term A2 Signal											
H3-09	Multi-function analog input terminal A2 function selection	Select multi-function analog input function for terminal A2. Refer to the next table.	0 to 1F	0	No	A	A	A	A	A	418H	6-25
	Terminal A2 Sel											
H3-10	Gain (terminal A2)	Sets the input gain (level) when terminal 14 is 10 V (20 mA). Set according to the 100% value for the function set for H3-09.	0.0 to 1000.0	100.0%	Yes	A	A	A	A	A	419H	6-25
	Terminal A2 Gain											
H3-11	Bias (terminal A2)	Sets the input gain (level) when terminal 14 is 0 V (4 mA). Set according to the 100% value for the function set for H3-09.	-100.0 to +100.0	0.0%	Yes	A	A	A	A	A	41AH	6-25
	Terminal A2 Bias											
H3-12	Analog input filter time constant	Sets primary delay filter time constant in seconds for the two analog input terminal (A1 and A2). Effective for noise control etc.	0.00 to 2.00	0.03 s	No	A	A	A	A	A	41BH	6-25
	Filter Avg Time											

H3-05,H3-09 Settings

Setting Value	Function	Contents (100%)	Control Methods					Page
			V/f	V/f with PG	Open Loop Vector 1	Flux Vector	Open Loop Vector 2	
0	Add to terminal A1	Maximum output frequency	Yes	Yes	Yes	Yes	Yes	6-26
1	Frequency gain	Frequency reference (voltage) command value	Yes	Yes	Yes	Yes	Yes	6-26
2	Auxiliary frequency reference (2nd step analog)	Maximum output frequency	Yes	Yes	Yes	Yes	Yes	6-26
3	Auxiliary frequency reference 2 (3rd step analog)	Maximum output frequency	Yes	Yes	Yes	Yes	Yes	6-26
4	Voltage bias	Motor rated voltage (E1-05)	Yes	Yes	No	No	No	-
5	Accel/decel change (reduction coefficient)	Set acceleration and deceleration times (C1-01 to C1-08)	Yes	Yes	Yes	Yes	Yes	6-17
6	DC injection braking current	Inverter rated output current	Yes	Yes	Yes	No	No	6-14
7	Overtorque/undertorque detection level	Motor rated torque for vector control Inverter rated output current for V/f control	Yes	Yes	Yes	Yes	Yes	6-48
8	Stall prevention level during run	Inverter rated output current	Yes	Yes	No	No	No	6-44
9	Frequency reference lower limit level	Maximum output frequency	Yes	Yes	Yes	Yes	Yes	6-31
A	Jump frequency	Maximum output frequency	Yes	Yes	Yes	Yes	Yes	6-28
B	PID feedback	Maximum output frequency	Yes	Yes	Yes	Yes	Yes	6-97
C	PID target value	Maximum output frequency	Yes	Yes	Yes	Yes	Yes	6-97
E	Motor temperature input	10 V = 100%	Yes	Yes	Yes	Yes	Yes	6-53
10	Positive torque limit	Motor's rated torque	No	No	Yes	Yes	Yes	6-38
11	Negative torque limit	Motor's rated torque	No	No	Yes	Yes	Yes	6-38
12	Regenerative torque limit	Motor's rated torque	No	No	Yes	Yes	Yes	6-38
13	Torque reference/torque limit at speed control	Motor's rated torque	No	No	No	Yes	Yes	6-116
14	Torque compensation	Motor's rated torque	No	No	No	Yes	Yes	6-116
15	Positive/negative torque limit	Motor's rated torque	No	No	Yes	Yes	Yes	6-38
1F	Analog input not used.	-	Yes	Yes	Yes	Yes	Yes	6-6
13, 14, 16 to 1E	Not used	-	-	-	-	-	-	-

Multi-function Analog Outputs: H4

User constants for multi-function analog outputs are shown in the following table.

Constant Number	Name	Description	Setting Range	Factory Setting	Change during Operation	Control Methods					MEMO BUS Register	Page
	Display					V/f	V/f with PG	Open Loop Vector 1	Flux Vector	Open Loop Vector 2		
H4-01	Monitor selection (terminal FM)	Sets the number of the monitor item to be output (U1-□□) from terminal FM. 4, 10 to 14, 25, 28, 34, 39, 40 cannot be set. 29 to 31 and 41 are not used.	1 to 45	2	No	A	A	A	A	A	41DH	6-76
	Terminal FM Sel											
H4-02	Gain (terminal FM)	Sets the multi-function analog output 1 voltage level gain. Sets whether the monitor item output will be output in multiples of 10 V. The maximum output from the terminal is 10 V. A meter calibration function is available.	0.00 to 2.50 (0 to 1000.0)	1.00 (100%)	Yes	Q	Q	Q	Q	Q	41EH	4-6 6-76
	Terminal FM Gain											
H4-03	Bias (terminal FM)	Sets the multi-function analog output 1 voltage level bias. Sets output characteristic up/down parallel movement as a percentage of 10 V. The maximum output from the terminal is 10 V. A meter calibration function is available.	-10.0 to +10.0 (-100.0 to 100.0)	0.0% (0.0%)	Yes	A	A	A	A	A	41FH	4-6
	Terminal FM Bias											
H4-04	Monitor selection (terminal AM)	Sets the number of the monitor item to be output (U1-□□) from terminal AM. 4, 10 to 14, 25, 28, 34, 39, 40 cannot be set. 29 to 31 and 41 are not used.	1 to 45	3	No	A	A	A	A	A	420H	4-6 6-76
	Terminal AM Sel											
H4-05	Gain (terminal AM)	Set the voltage level gain for multi-function analog output 2. Set the number of multiples of 10 V to be output as the 100% output for the monitor items. The maximum output from the terminal is 10 V. A meter calibration function is available.	0.00 to 2.50 (0 to 1000.0)	0.50 (200%)	Yes	Q	Q	Q	Q	Q	421H	4-6 6-76
	Terminal AM Gain											
H4-06	Bias (terminal AM)	Sets the multi-function analog output 2 voltage level bias. Sets output characteristic up/down parallel movement as a percentage of 10 V. The maximum output from the terminal is 10 V. A meter calibration function is available.	-10.0 to +10.0 (0 to 1000.0)	0.0% (0.0%)	Yes	A	A	A	A	A	422H	-
	Terminal AM Bias											
H4-07	Analog output 1 signal level selection	Sets the signal output level for multi-function output 1 (terminal FM) 0: 0 to +10 V output 1: 0 to ±10 V output	0 or 1	0	No	A	A	A	A	A	423H	-
	AO Level Select1											

Constant Number	Name	Description	Setting Range	Factory Setting	Change during Operation	Control Methods					MEMO BUS Register	Page
	Display					V/f	V/f with PG	Open Loop Vector 1	Flux Vector	Open Loop Vector 2		
H4-08	Analog output 2 signal level selection	Sets the signal output level for multi-function output 2 (terminal AM) 0: 0 to +10 V output 1: 0 to ±10 V output	0 or 1	0	No	A	A	A	A	A	424H	-
	AO Level Select2											

MEMOBUS Communications: H5

User constants for MEMOBUS communications are shown in the following table.

Constant Number	Name	Description	Setting Range	Factory Setting	Change during Operation	Control Methods					MEMO BUS Register	Page
	Display					V/f	V/f with PG	Open Loop Vector 1	Flux Vector	Open Loop Vector 2		
H5-01	Station address	Set the Inverter's node address.	0 to 20*	1F	No	A	A	A	A	A	425H	6-83
	Serial Comm Adr											
H5-02	Communication speed selection	Set the baud rate for 6CN MEMOBUS communications. 0: 1200 bps 1: 2400 bps 2: 4800 bps 3: 9600 bps 4: 19200 bps	0 to 4	3	No	A	A	A	A	A	426H	6-83
	Serial Baud Rate											
H5-03	Communication parity selection	Set the parity for 6CN MEMOBUS communications. 0: No parity 1: Even parity 2: Odd parity	0 to 2	0	No	A	A	A	A	A	427H	6-83
	Serial Com Sel											
H5-04	Stopping method after communication error	Set the stopping method for communications errors. 0: Deceleration to stop using deceleration time in C1-02 1: Coast to stop 2: Emergency stop using deceleration time in C1-09 3: Continue operation	0 to 3	3	No	A	A	A	A	A	428H	6-83
	Serial Fault Sel											
H5-05	Communication error detection selection	Set whether or not a communications timeout is to be detected as a communications error. 0: Do not detect. 1: Detect	0 or 1	1	No	A	A	A	A	A	429H	6-83
	Serial Flt Dct											
H5-06	Send wait time	Set the time from the Inverter receiving data to when the Inverter starts to send.	5 to 65	5 ms	No	A	A	A	A	A	42AH	6-83
	Transmit WaitTIM											

Constant Number	Name	Description	Setting Range	Factory Setting	Change during Operation	Control Methods					MEMO BUS Register	Page
	Display					V/f	V/f with PG	Open Loop Vector 1	Flux Vector	Open Loop Vector 2		
H5-07	RTS control ON/OFF	Select to enable or disable RTS control. 0: Disabled (RTS is always ON)	0 or 1	1	No	A	A	A	A	A	42BH	6-83
	RTS Control Sel	1: Enabled (RTS turns ON only when sending)										

* Set H5-01 to 0 to disable Inverter responses to MEMOBUS communications.

■ Pulse Train I/O: H6

User constants for pulse I/O are shown in the following table.

Constant Number	Name	Description	Setting Range	Factory Setting	Change during Operation	Control Methods					MEMO BUS Register	Page
	Display					V/f	V/f with PG	Open Loop Vector 1	Flux Vector	Open Loop Vector 2		
H6-01	Pulse train input function selection	0: Frequency reference 1: PID feedback value 2: PID target value	0 to 2	0	No	A	A	A	A	A	42CH	6-2 6-29 6-96
	Pulse Input Sel											
H6-02	Pulse train input scaling	Set the number of pulses in hertz, taking the reference to be 100%.	1000 to 32000	1440 Hz	Yes	A	A	A	A	A	42DH	6-2 6-29
	PI Scaling											
H6-03	Pulse train input gain	Set the input gain level as a percent when the pulse train set in H6-02 is input.	0.0 to 1000.0	100.0%	Yes	A	A	A	A	A	42EH	6-29
	Pulse Input Gain											
H6-04	Pulse train input bias	Set the input bias when the pulse train is 0.	-100.0 to 100.0	0.0%	Yes	A	A	A	A	A	42FH	6-29
	Pulse Input Bias											
H6-05	Pulse train input filter time	Set the pulse train input primary delay filter time constant in seconds.	0.00 to 2.00	0.10 s	Yes	A	A	A	A	A	430H	6-29
	PI Filter Time											
H6-06	Pulse train monitor selection	Select the pulse train monitor output items (value of the <input type="checkbox"/> <input type="checkbox"/> part of U1- <input type="checkbox"/> <input type="checkbox"/>). There are two types of monitor items: Speed-related items and PID-related items.	1, 2, 5, 20, 24, 36	2	Yes	A	A	A	A	A	431H	6-79
	Pulse Output Sel											
H6-07	Pulse train monitor scaling	Set the number of pulses output when speed is 100% in hertz. Set H6-06 to 2, and H6-07 to 0, to make the pulse train monitor output synchronously to the output frequency.	0 to 32000	1440 Hz	Yes	A	A	A	A	A	432H	6-79
	PO Scaling											

◆ Protection Function Constants: L

The following settings are made with the protection function constants (L constants): Motor selection function, power loss ride-through function, stall prevention function, frequency detection, torque limits, and hardware protection.

■ Motor Overload: L1

User constants for motor overloads are shown in the following table.

Constant Number	Name	Description	Setting Range	Factory Setting	Change during Operation	Control Methods					MEMO BUS Register	Page
	Display					V/f	V/f with PG	Open Loop Vector 1	Flux Vector	Open Loop Vector 2		
L1-01	Motor protection selection	Sets whether the motor overload function is enabled or disabled at electric thermal overload relay. 0: Disabled 1: General-purpose motor protection 2: Inverter motor protection 3: Vector motor protection In some applications when the Inverter power supply is turned off, the thermal value is reset, so even if this constant is set to 1, protection may not be effective. When several motors are connected to one Inverter, set to 0 and ensure that each motor is installed with a protection device.	0 to 3	1	No	Q	Q	Q	Q	Q	480H	4-5 6-49
	MOL Fault Select											
L1-02	Motor protection time constant	Sets the electric thermal detection time in seconds units. Usually setting is not necessary. The factory setting is 150% overload for one minute. When the motor's overload resistance is known, also set the overload resistance protection time for when the motor is hot started.	0.1 to 5.0	1.0 min	No	A	A	A	A	A	481H	6-49
	MOL Time Const											
L1-03	Alarm operation selection during motor overheating	Set H3-09 to E and select the operation when the input motor temperature (thermistor) input exceeds the alarm detection level (1.17 V). 0: Decelerate to stop 1: Coast to stop 2: Emergency stop using the deceleration time in C1-09. 3: Continue operation (H3 on the Operator flashes).	0 to 3	3	No	A	A	A	A	A	482H	6-52
	MOL Thm Input											

Constant Number	Name	Description	Setting Range	Factory Setting	Change during Operation	Control Methods					MEMO BUS Register	Page
	Display					V/f	V/f with PG	Open Loop Vector 1	Flux Vector	Open Loop Vector 2		
L1-04	Motor over-heating operation selection	Set H3-09 to E and select the operation when the motor temperature (thermistor) input exceeds the operation detection level (2.34 V). 0: Decelerate to stop 1: Coast to stop 2: Emergency stop using the deceleration time in C1-09.	0 to 2	1	No	A	A	A	A	A	483H	6-52
	MOL Filter Time											
L1-05	Motor temperature input filter time constant	Set H3-09 to E and set the primary delay time constant for motor temperature (thermistor) inputs in seconds.	0.00 to 10.00	0.20 s	No	A	A	A	A	A	484H	6-52
	MOL Filter Time											

■ Power Loss Ridethrough: L2

User constants for power loss ridethroughs are shown in the following table.

Constant Number	Name	Description	Setting Range	Factory Setting	Change during Operation	Control Methods					MEMO BUS Register	Page
	Display					V/f	V/f with PG	Open Loop Vector 1	Flux Vector	Open Loop Vector 2		
L2-01	Momentary power loss detection	0: Disabled (main circuit undervoltage (UV) detection) 1: Enabled (Restarted when the power returns within the time for L2-02. When L2-02 is exceeded, main circuit undervoltage detection.) 2: Enabled while CPU is operating. (Restarts when power returns during control operations. Does not detect main circuit undervoltage.)	0 to 2	0	No	A	A	A	A	A	485H	6-55
	PwrL Selection											
L2-02	Momentary power loss ridethru time	Ridethrough time, when Momentary Power Loss Selection (L2-01) is set to 1, in units of seconds.	0 to 25.5	0.1 s *	No	A	A	A	A	A	486H	6-55
	PwrL Ride-thru t											
L2-03	Min. base-block time	Sets the Inverter's minimum baseblock time in units of one second, when the Inverter is restarted after power loss ride-through. Sets the time to approximately 0.7 times the motor secondary circuit time constant. When an overcurrent or overvoltage occurs when starting a speed search or DC injection braking, increase the set values.	0.1 to 5.0	0.2 s *1	No	A	A	A	A	A	487H	6-55 6-57
	PwrL Base-block t											

Constant Number	Name	Description	Setting Range	Factory Setting	Change during Operation	Control Methods					MEMO BUS Register	Page
	Display					V/f	V/f with PG	Open Loop Vector 1	Flux Vector	Open Loop Vector 2		
L2-04	Voltage recovery time	Sets the time required to return the Inverter output voltage to normal voltage at the completion of a speed search, in units of one second.	0.0 to 5.0	0.3 s *1	No	A	A	A	A	A	488H	6-55 6-56
	PwrL V/F Ramp t	Sets the time required to recover from 0 V to the maximum voltage.										
L2-05	Undervoltage detection level	Sets the main circuit undervoltage (UV) detection level (main circuit DC voltage) in V units. Usually setting is not necessary. Insert an AC reactor in the Inverter input side to lower the main circuit undervoltage detection level.	150 to 210 *2	190 V *2	No	A	A	A	A	A	489H	6-56
	PUV Det Level											
L2-06	KEB deceleration time	Sets in seconds the time required to decelerate from the speed where the deceleration at momentary power loss command (KEB) is input to zero speed.	0.0 to 200.0	0.0 s	No	A	A	A	A	A	48AH	-
	KEB Frequency											
L2-07	Momentary recovery time	Set in seconds the time to accelerate to the set speed after recovery from a momentary power loss.	0.0 to 25.5	0.0 s *3	No	A	A	A	A	A	48BH	-
	UV RETURN TIME											
L2-08	Frequency reduction gain at KEB start	Sets as a percent the amount to reduce the output frequency at the beginning of deceleration at momentary power loss (KEB). Reduction = slip frequency before KEB operation × L2-08 × 2	0 to 300	100%	No	A	A	A	A	A	48CH	-
	KEB Decel Time											

* 1. The factory setting depends upon the Inverter capacity. The value for a 200 V Class Inverter of 0.4 kW is given.

* 2. These are values for a 200 V class Inverter. Value for a 400 V class Inverter is double.

* 3. If the setting is 0, the axis will accelerate to the specified speed over the specified acceleration time (C1-01 to C1-08).

■ Stall Prevention: L3

User constants for the stall prevention function are shown in the following table.

Constant Number	Name	Description	Setting Range	Factory Setting	Change during Operation	Control Methods					MEMO BUS Register	Page
	Display					V/f	V/f with PG	Open Loop Vector 1	Flux Vector	Open Loop Vector 2		
L3-01	Stall prevention selection during accel	0: Disabled (Acceleration as set. With a heavy load, the motor may stall.) 1: Enabled (Acceleration stopped when L3-02 level is exceeded. Acceleration starts again when the current is returned.) 2: Intelligent acceleration mode (Using the L3-02 level as a basis, acceleration is automatically adjusted. Set acceleration time is disregarded.)	0 to 2	1	No	A	A	A	No	No	48FH	6-20
	StallP Accel Sel											
L3-02	Stall prevention level during accel	Effective when L3-01 is set to 1 or 2. Set as a percentage of Inverter rated current. Usually setting is not necessary. The factory setting reduces the set values when the motor stalls.	0 to 200	150%	No	A	A	A	No	No	490H	6-20
	StallP Accel Lvl											
L3-03	Stall prevention limit during accel	Sets the lower limit for stall prevention during acceleration, as a percentage of the Inverter rated current, when operation is in the frequency range above E1-06. Usually setting is not necessary.	0 to 100	50%	No	A	A	A	No	No	491H	6-20
	StallP CHP Lvl											
L3-04	Stall prevention selection during decel	0: Disabled (Deceleration as set. If deceleration time is too short, a main circuit overvoltage may result.) 1: Enabled (Deceleration is stopped when the main circuit voltage exceeds the overvoltage level. Deceleration restarts when voltage is returned.) 2: Intelligent deceleration mode (Deceleration rate is automatically adjusted so that in Inverter can decelerate in the shortest possible time. Set deceleration time is disregarded.) 3: Enabled (with Braking Resistor Unit) When a braking option (Braking Resistor, Braking Resistor Unit, Braking Unit) is used, always set to 0 or 3.	0 to 3*	1	No	Q	Q	Q	Q	Q	492H	4-6 6-22
	StallP Decel Sel											

Constant Number	Name	Description	Setting Range	Factory Setting	Change during Operation	Control Methods					MEMO BUS Register	Page
	Display					V/f	V/f with PG	Open Loop Vector 1	Flux Vector	Open Loop Vector 2		
L3-05	Stall prevention selection during running	0: Disabled (Runs as set. With a heavy load, the motor may stall.) 1: Deceleration time 1 (the deceleration time for the stall prevention function is C1-02.) 2: Deceleration time 2 (the deceleration time for the stall prevention function is C1-04.)	0 to 2	1	No	A	A	No	No	No	493H	6-43
	StallP Run Sel											
L3-06	Stall prevention level during running	Effective when L3-05 is 1 or 2. Set as a percentage of the Inverter rated current. Usually setting is not necessary. The factory setting reduces the set values when the motor stalls.	30 to 200	160%	No	A	A	No	No	No	494H	6-43
	StallP Run Level											

* The setting range is 0 to 2 for flux vector control and open-loop vector control 2.

■Reference Detection: L4

User constants for the reference detection function are shown in the following table.

Constant Number	Name	Description	Setting Range	Factory Setting	Change during Operation	Control Methods					MEMO BUS Register	Page
	Display					V/f	V/f with PG	Open Loop Vector 1	Flux Vector	Open Loop Vector 2		
L4-01	Speed agreement detection level	Effective when "Desired frequency (ref/setting) agree 1," "Frequency detection 1," or "Frequency detection 2" is set for a multi-function output. Frequencies to be detected are set in Hz units.	0.0 to 400.0	0.0 Hz	No	A	A	A	A	A	499H	-
	Spd Agree Level											
L4-02	Speed agreement detection width	Effective when "Frequency (speed) agree 1," "Desired frequency (speed) agree 1," or "Frequency (FOUT) detection 1," is set for a multi-function output. Sets the frequency detection width in Hz units.	0.0 to 20.0	2.0 Hz	No	A	A	A	A	A	49AH	-
	Spd Agree Width											
L4-03	Speed agreement detection level (+/-)	Effective when "Desired frequency (speed) agree 2," "Desired frequency (speed) agree 1" "Frequency (FOUT) detection 3," or "Frequency (FOUT) detection 4" is set for a multi-function output. Frequency detection width is set in Hz units.	-400.0 to +400.0	0.0 Hz	No	A	A	A	A	A	49BH	-
	Spd Agree Lvl+-											

Constant Number	Name	Description	Setting Range	Factory Setting	Change during Operation	Control Methods					MEMO BUS Register	Page
	Display					V/f	V/f with PG	Open Loop Vector 1	Flux Vector	Open Loop Vector 2		
L4-04	Speed agreement detection width (+/-)	Effective when "Frequency (speed) agree 2," "Desired frequency (speed) agree 1," or "Frequency detection 4" is set for a multi-function output. Frequency detection width is set in Hz units.	0.0 to 20.0	2.0 Hz	No	A	A	A	A	A	49CH	-
	Spd Agree Wdth+-											
L4-05	Operation when frequency reference is missing	0: Stop (Operation follows the frequency reference.) 1: Operation at 80% speed continues. (At 80% of speed before the frequency reference was lost)	0 or 1	0	No	A	A	A	A	A	49DH	6-62
	Ref Loss Sel	Frequency reference is lost: Frequency reference dropped over 90% in 400 ms.										

■ Fault Restart: L5

User constants for restarting faults are shown in the following table.

Constant Number	Name	Description	Setting Range	Factory Setting	Change during Operation	Control Methods					MEMO BUS Register	Page
	Display					V/f	V/f with PG	Open Loop Vector 1	Flux Vector	Open Loop Vector 2		
L5-01	Number of auto restart attempts	Sets the number of auto restart attempts. Automatically restarts after a fault and conducts a speed search from the run frequency.	0 to 10	0	No	A	A	A	A	A	49EH	6-63
	Num of Restarts											
L5-02	Auto restart operation selection	Sets whether a fault contact output is activated during fault restart. 0: Not output (Fault contact is not activated.) 1: Output (Fault contact is activated.)	0 or 1	0	No	A	A	A	A	A	49FH	6-63
	Restart Sel											

■ Torque Detection: L6

User constants for the torque detection function are shown in the following table.

Constant Number	Name	Description	Setting Range	Factory Setting	Change during Operation	Control Methods					MEMO BUS Register	Page
	Display					V/f	V/f with PG	Open Loop Vector 1	Flux Vector	Open Loop Vector 2		
L6-01	Torque detection selection 1	0: Overtorque/undertorque detection disabled. 1: Overtorque detection only with speed agreement; operation continues after overtorque (warning). 2: Overtorque detected continuously during operation; operation continues after overtorque (warning). 3: Overtorque detection only with speed agreement; output stopped upon detection (protected operation). 4: Overtorque detected continuously during operation; output stopped upon detection (protected operation). 5: Undertorque detection only with speed agreement; operation continues after overtorque (warning). 6: Undertorque detected continuously during operation; operation continues after overtorque (warning). 7: Undertorque detection only with speed agreement; output stopped upon detection (protected operation). 8: Undertorque detected continuously during operation; output stopped upon detection (protected operation).	0 to 8	0	No	A	A	A	A	A	4A1H	6-45
	Torq Det 1 Sel											
L6-02	Torque detection level 1	Open-loop vector control: Motor rated torque is set as 100%.	0 to 300	150%	No	A	A	A	A	A	4A2H	6-45
	Torq Det 1 Lvl	V/f control: Inverter rated current is set as 100%.										
L6-03	Torque detection time 1	Sets the overtorque/undertorque detection time in 1-second units.	0.0 to 10.0	0.1 s	No	A	A	A	A	A	4A3H	6-45
	Torq Det 1 Time											

Constant Number	Name	Description	Setting Range	Factory Setting	Change during Operation	Control Methods					MEMO BUS Register	Page
	Display					V/f	V/f with PG	Open Loop Vector 1	Flux Vector	Open Loop Vector 2		
L6-04	Torque detection selection 2	Multi-function output for overtorque detection 1 is output to multi-function contact output when overtorque detection 1 NO or overtorque detection 1 NC is selected. Multi-function output for overtorque detection 2 is output to multi-function contact output when overtorque detection 2 NO or overtorque detection 2 NC is selected.	0 to 8	0	No	A	A	A	A	A	4A4H	6-45
	Torq Det 2 Sel											
L6-05	Torque detection level 2		0 to 300	150%	No	A	A	A	A	A	4A5H	6-45
	Torq Det 2 Lvl											
L6-06	Torque detection time 2		0.0 to 10.0	0.1 s	No	A	A	A	A	A	4A6H	6-45
	Torq Det 2 Time											

■ Torque Limits: L7

User constants for torque limits are shown in the following table.

Constant Number	Name	Description	Setting Range	Factory Setting	Change during Operation	Control Methods					MEMO BUS Register	Page
						V/f	V/f with PG	Open Loop Vector 1	Flux Vector	Open Loop Vector 2		
L7-01	Forward drive torque limit	Sets the torque limit value as a percentage of the motor rated torque. Four individual regions can be set.	0 to 300	200%	No	No	No	A	A	A	4A7H	6-38
	Torq Limit Fwd											
L7-02	Reverse drive torque limit		0 to 300	200%	No	No	No	A	A	A	4A8H	6-38
	Torq Limit Rev											
L7-03	Forward regenerative torque limit		0 to 300	200%	No	No	No	A	A	A	4A9H	6-38
	Torq Lmt Fwd Rgn											
L7-04	Reverse regenerative torque limit	0 to 300	200%	No	No	No	A	A	A	4AAH	6-38	
	Torq Lmt Rev Rgn											

■ Hardware Protection: L8

User constants for hardware protection functions are shown in the following table.

Constant Number	Name	Description	Setting Range	Factory Setting	Change during Operation	Control Methods					MEMO BUS Register	Page
	Display					V/f	V/f with PG	Open Loop Vector 1	Flux Vector	Open Loop Vector 2		
L8-01	Protect selection for internal DB resistor (Type ERF)	0: Disabled (no overheating protection) 1: Enabled (overheating protection)	0 or 1	0	No	A	A	A	A	A	4ADH	6-64
	DB Resistor Prot											
L8-02	Overheat pre-alarm level	Sets the detection temperature for the Inverter overheat detection pre-alarm in °C. The pre-alarm detects when the cooling fin temperature reaches the set value.	50 to 130	95 °C*	No	A	A	A	A	A	4AEH	6-65
	OH Pre-Alarm Lvl											
L8-03	Operation selection after overheat pre-alarm	Sets the operation for when the Inverter overheat pre-alarm goes ON. 0: Decelerate to stop in deceleration time C1-02. 1: Coast to stop 2: Fast stop in fast-stop time C1-09. 3: Continue operation (Monitor display only.) A fault will be given in setting 0 to 2 and a minor fault will be given in setting 3.	0 to 3	3	No	A	A	A	A	A	4AFH	6-65
	OH Pre-Alarm Sel											
L8-05	Input open-phase protection selection	0: Disabled 1: Enabled (Detects if input current open-phase, power supply voltage imbalance or main circuit electrostatic capacitor deterioration occurs.)	0 or 1	0	No	A	A	A	A	A	4B1H	-
	Ph Loss In Sel											
L8-07	Output open-phase protection selection	0: Disabled 1: Enabled 2: Enabled Output open-phase is detected at less than 5% of Inverter rated current. When applied motor capacity is small for Inverter capacity, output open-phase may be detected inadvertently or open-phase may not be detected. In this case, set to 0.	0 to 2	0	No	A	A	A	A	A	4B3H	-
	Ph Loss Out Sel											
L8-09	Ground protection selection	0: Disabled 1: Enabled	0 or 1	1	No	A	A	A	A	A	4B5H	-
	Ground Fault Sel											

Constant Number	Name	Description	Setting Range	Factory Setting	Change during Operation	Control Methods					MEMO BUS Register	Page
	Display					V/f	V/f with PG	Open Loop Vector 1	Flux Vector	Open Loop Vector 2		
L8-10	Cooling fan control selection	Set the ON/OFF control for the cooling fan. 0: ON only when Inverter is ON 1: ON whenever power is ON	0 or 1	0	No	A	A	A	A	A	4B6H	-
	FAN Control Sel											
L8-11	Cooling fan control delay time	Set the time in seconds to delay turning OFF the cooling fan after the cooling fan OFF command is received.	0 to 300	60 s	No	A	A	A	A	A	4B7H	-
	FAN OFF TIM											
L8-12	Ambient temperature	Set the ambient temperature.	45 to 60	45 °C	No	A	A	A	A	A	4B8H	-
	temp											
L8-15	OL2 characteristics selection at low speeds	0: OL2 characteristics at low speeds disabled. 1: OL2 characteristics at low speeds enabled.	0 or 1	1	No	A	A	A	A	A	4BBH	-
	OL2 Chara@L-Spd											
L8-18	Soft CLA selection	0: Disable 1: Enable	0 or 1	1	No	A	A	A	A	A	4BFH	-
	Soft CLA Sel											

* The factory setting depends upon the Inverter capacity. The value for a 200 V Class Inverter of 0.4 kW is given.

◆ N: Special Adjustments

The following settings are made with the special adjustments constants (N constants): Hunting prevention and speed feedback detection control.

■ Hunting Prevention Function: N1

User constants for hunting prevention are shown in the following table.

Con- stant Number	Name	Description	Setting Range	Factory Setting	Change during Opera- tion	Control Methods					MEMO BUS Regis- ter	Page
	Display					V/f	V/f with PG	Open Loop Vec- tor 1	Flux Vec- tor	Open Loop Vec- tor 2		
N1-01	Hunting-pre- vention func- tion selection	0: Hunting-prevention function disabled 1: Hunting-prevention function enabled	0 or 1	1	No	A	A	No	No	No	580H	6-36
	Hunt Prev Select	The hunting-prevention func- tion suppresses hunting when the motor is operating with a light load. This function is enabled in V/ f control method only. If high response is to be given priority over vibration sup- pression, disable the hunting- prevention function.										
N1-02	Hunting-pre- vention gain	Set the hunting-prevention gain multiplication factor. Normally, there is no need to make this setting. Make the adjustments as fol- lows:	0.00 to 2.50	1.00	No	A	A	No	No	No	581H	4-16 6-36
	Hunt Prev Gain	<ul style="list-style-type: none"> • If vibration occurs with light load, increase the set- ting. • If the motor stalls, reduce the setting. If the setting is too large, the voltage will be too suppressed and the motor may stall.										

■ Speed Feedback Protection Control Functions: N2

User constants for speed feedback protection control functions are shown in the following table.

Constant Number	Name	Description	Setting Range	Factory Setting	Change during Operation	Control Methods					MEMO BUS Register	Page
	Display					V/f	V/f with PG	Open Loop Vector 1	Flux Vector	Open Loop Vector 2		
N2-01	Speed feedback detection control (AFR) gain	Set the internal speed feedback detection control gain using the multiplication function. Normally, there is no need to make this setting. Adjust this constant as follows: • If hunting occurs, increase the set value. • If response is low, decrease the set value. Adjust the setting by 0.05 at a time, while checking the response.	0.00 to 10.00	1.00	No	No	No	A	No	No	584H	4-16 6-37
	AFR Gain											
N2-02	Speed feedback detection control (AFR) time constant	Set the time constant to decide the rate of change in the speed feedback detection control.	0 to 2000	50 ms	No	No	No	A	No	No	585H	6-37
	AFR Time											
N2-03	Speed feedback detection control (AFR) time constant 2	Set the time constant to decide the amount of change in the speed.	0 to 2000	750 ms	No	No	No	A	No	No	586H	6-37
	AFR Time 2											

■ High-slip Braking: N3

User constants for high-slip braking are shown in the following table.

Constant Number	Name	Description	Setting Range	Factory Setting	Change during Operation	Control Methods					MEMO BUS Register	Page
	Display					V/f	V/f with PG	Open Loop Vector 1	Flux Vector	Open Loop Vector 2		
N3-01	High-slip braking deceleration frequency width	Sets the frequency width for deceleration during high-slip braking as a percent, taking the Maximum Frequency (E1-04) as 100%.	1 to 20	5%	No	A	A	No	No	No	588H	-
	HSB Down Freq											
N3-02	High-slip braking current limit	Sets the current limit for deceleration during high-slip braking as a percent, taking the motor rated current as 100%. The resulting limit must be 150% of the Inverter rated current or less.	100 to 200	150%	No	A	A	No	No	No	589H	-
	HSB Current											

Constant Number	Name	Description	Setting Range	Factory Setting	Change during Operation	Control Methods					MEMO BUS Register	Page
	Display					V/f	V/f with PG	Open Loop Vector 1	Flux Vector	Open Loop Vector 2		
N3-03	High-slip braking stop dwell time	Set in seconds the dwell time for the output frequency for FMIN (1.5 Hz) during V/f control. Effective only during deceleration for high-slip braking.	0.1 to 10.0	1.0 s	No	A	A	No	No	No	58AH	-
	HSB Dwell Time											
N3-04	High-slip braking OL time	Set the OL time when the output frequency does not change for some reason during deceleration for high-slip braking.	30 to 1200	40 s	No	A	A	No	No	No	58BH	-
	HSB OL Time											

■Speed Estimation: N4

User constants for speed estimation are shown in the following table.

Constant Number	Name	Description	Setting Range	Factory Setting	Change during Operation	Control Methods					MEMO BUS Register	Page
	Display					V/f	V/f with PG	Open Loop Vector 1	Flux Vector	Open Loop Vector 2		
N4-07	Integral time of speed estimator	Set the integral time of the speed estimator for PI control.	0.000 to 9.999	0.060 ms	No	No	No	No	No	A	59AH	-
	SPD EST I Time											
N4-08	Proportional gain of speed estimator	Set the proportional gain of the speed estimator for PI control.	0 to 1000	15	No	No	No	No	No	A	59BH	-
	SPD EST P GAIN											
N4-17	Torque adjustment gain	Set the torque adjustment gain for low-speed power.	0.0 to 5.0	0.8	No	No	No	No	No	A	5A4H	-
	TRQ adjust gain											
N4-18	Feeder resistance adjustment gain	Set the gain for the feeder resistance in the speed estimator.	0.90 to 1.30	1.00	No	No	No	No	No	A	5A5H	-
	Feeder R gain											

■ Feed Forward: N5

User constants for the feed forward control are shown in the following table.

Constant Number	Name	Description	Setting Range	Factory Setting	Change during Operation	Control Methods					MEMO BUS Register	Page
	Display					V/f	V/f with PG	Open Loop Vector 1	Flux Vector	Open Loop Vector 2		
N5-01	Feed forward control selection	Select the feed forward control. 0: Disabled 1: Enabled	0 or 1	0*1	No	No	No	No	A	A	5B0H	-
	Feedforward Sel											
N5-02	Motor acceleration time	Set the time required to accelerate the motor at the rated torque (T_{100}) to the rated speed (N_r). J: $GO^2/4$, P: Motor rated output $t_a = \frac{2\pi \cdot J [\text{kgm}^2] \cdot N_r [\text{r/min}]}{60 \cdot T_{100} [\text{N} \cdot \text{m}]} [\text{s}]$ However, $T_{100} = \frac{60}{2\pi} \frac{P [\text{kW}]}{N_r [\text{r/min}]} \times 10^3 [\text{N} \cdot \text{m}]$	0.000 to 10.000	0.178 s*2	No	No	No	No	A	A	5B1H	-
	Motor Accel Time											
N5-03	Feed forward proportional gain	Set the proportional gain for feed forward control. Speed reference response will increase as the setting of N5-03 is increased.	0.00 to 100.00	1.0	No	No	No	No	A	A	5B2H	-
	Feedforward Gain											

* 1. The factory setting will change when the control method is changed. (Flux vector control factory settings are given.)

* 2. The factory setting depends on the inverter capacity.

◆ Digital Operator Constants: o

The following settings are made with the Digital Operator constants (o constants): Multi-function selections and the copy function.

■ Monitor Select: o1

User constants for Digital Operator Displays are shown in the following table.

Constant Number	Name	Description	Setting Range	Factory Setting	Change during Operation	Control Methods					MEMO BUS Register	Page
	Display					V/f	V/f with PG	Open Loop Vector 1	Flux Vector	Open Loop Vector 2		
o1-01	Monitor selection	Set the number of the monitor item to be displayed in the earliest 4 monitor items. (U1-□□) The output monitor voltage (factory setting) can be changed.	4 to 45	6	Yes	A	A	A	A	A	500H	-
	User Monitor Sel											

Constant Number	Name	Description	Setting Range	Factory Setting	Change during Operation	Control Methods					MEMO BUS Register	Page
	Display					V/f	V/f with PG	Open Loop Vector 1	Flux Vector	Open Loop Vector 2		
o1-02	Monitor selection after power up	Sets the monitor item to be displayed when the power is turned on. 1: Frequency reference 2: Output frequency 3: Output current 4: The monitor item set for o1-01	1 to 4	1	Yes	A	A	A	A	A	501H	6-132
	Power-On Monitor											
o1-03	Frequency units of reference setting and monitor	Sets the units that will be set and displayed for the frequency reference and frequency monitor. 0: 0.01 Hz units 1: 0.01% units (Maximum output frequency is 100%) 2 to 39: min ⁻¹ units (Sets the motor poles.) 40 to 39999: User desired display Set the desired values for setting and display for the max. output frequency. □ □ □ □ □ ↑ ↑ Set 4-digit number excluding the decimal point. Set the number of digits below the decimal point to display. Example: When the max. output frequency value is 200.0, set 12000	0 to 39999	0	No	A	A	A	A	A	502H	6-132
	Display Scaling											
o1-04	Setting unit for frequency constants related to V/f characteristics	Set the setting unit for frequency reference-related constants. 0: Hz 1: min ⁻¹	0 or 1	0	No	No	No	No	A	A	503H	6-132
	V/f Display Unit											
o1-05	LCD brightness adjustment	Set a smaller value to lighten the LCD and a larger value to darken the LCD (standard: 3).	0 to 5	3	Yes	A	A	A	A	A	504H	-
	LCD Contrast											

Multi-function Selections: o2

User constants for Digital Operator key functions are shown in the following table.

Constant Number	Name	Description	Setting Range	Factory Setting	Change during Operation	Control Methods					MEMO BUS Register	Page
	Display					V/f	V/f with PG	Open Loop Vector 1	Flux Vector	Open Loop Vector 2		
o2-01	LOCAL/REMOTE key enable/disable	Sets the Digital Operator Local/Remote Key 0: Disabled 1: Enabled (Switches between the Digital Operator and the constant settings.)	0 or 1	1	No	A	A	A	A	A	505H	6-132
	Local/Remote Key											
o2-02	STOP key during control circuit terminal operation	Sets the Stop Key in the run mode. 0: Disabled (When the run command is issued from and external terminal, the Stop Key is disabled.) 1: Enabled (Effective even during run.)	0 or 1	1	No	A	A	A	A	A	506H	6-132
	Oper STOP Key											
o2-03	User constant initial value	Clears or stores user initial values. 0: Stores/not set 1: Begins storing (Records the set constants as user initial values.) 2: All clear (Clears all recorded user initial values) When the set constants are recorded as user initial values, 1110 will be set in A1-03.	0 to 2	0	No	A	A	A	A	A	507H	6-133
	User Defaults											
o2-04	kVA selection	Do not set.	0 to FF	0*	No	A	A	A	A	A	508H	-
	Inverter Model #											
o2-05	Frequency reference setting method selection	When the frequency reference is set on the Digital Operator frequency reference monitor, sets whether the Enter Key is necessary. 0: Enter Key needed 1: Enter Key not needed When set to 1, the Inverter accepts the frequency reference without Enter Key operation.	0 or 1	0	No	A	A	A	A	A	509H	6-133
	Operator M.O.P.											
o2-06	Operation selection when digital operator is disconnected	Sets the operation when the Digital Operator is disconnected. 0: Disabled (Operation continues even if the Digital Operator is disconnected.) 1: Enabled (OPR is detected at Digital Operator disconnection. Inverter output is cut off, and fault contact is operated.)	0 or 1	0	No	A	A	A	A	A	50AH	-
	Oper Detection											

Constant Number	Name	Description	Setting Range	Factory Setting	Change during Operation	Control Methods					MEMO BUS Register	Page
	Display					V/f	V/f with PG	Open Loop Vector 1	Flux Vector	Open Loop Vector 2		
o2-07	Cumulative operation time setting	Sets the cumulative operation time in hour units. Operation time is calculated from the set values.	0 to 65535	0 hr	No	A	A	A	A	A	50BH	6-133
	Elapsed Time Set											
o2-08	Cumulative time selection	0: Cumulative time when the Inverter power is on. (All time while the Inverter power is on is accumulated.) 1: Cumulative Inverter run time. (Only Inverter output time is accumulated.)	0 or 1	0	No	A	A	A	A	A	50CH	-
	Elapsed Time Run											
o2-10	Fan operation time setting	Set the initial value of the fan operation time using time units. The operation time accumulates from the set value.	0 to 65535	0 hr	No	A	A	A	A	A	50EH	6-133
	Fan ON Time Set											
o2-12	Fault trace/fault history clear function	0: Disabled (U2 and U3 constants are on hold.) 1: Enabled (Initializes U2 and U3 constants.)	0 or 1	0	No	A	A	A	A	A	510H	-
	Fault Trace Init											

* The factory setting depends upon the Inverter capacity. The value for a 200 V class Inverter of 0.4 kW is given.

■ Copy Function: o3

User constants for the copy function are shown in the following table.

Constant Number	Name	Description	Setting Range	Factory Setting	Change during Operation	Control Methods					MEMO BUS Register	Page
	Display					V/f	V/f with PG	Open Loop Vector 1	Flux Vector	Open Loop Vector 2		
o3-01	Copy function selection	0: Normal operation 1: READ (Inverter to Operator) 2: COPY (Operator to Inverter) 3: Verify (compare)	0 to 3	0	No	A	A	A	A	A	515H	6-135
	Copy Function Sel											
o3-02	Read permitted selection	0: Read prohibited 1: Read permitted	0 or 1	0	No	A	A	A	A	A	516H	6-135
	Copy Allowable											

◆ T: Motor Autotuning

The following settings are made with the motor autotuning constants (T constants): Settings for autotuning.

Constant Number	Name	Description	Setting Range	Factory Setting	Change during Operation	Control Methods					MEMO BUS Register	Page
	Display					V/f	V/f with PG	Open Loop Vector 1	Flux Vector	Open Loop Vector 2		
T1-00	Motor 1/2 selection	Set the location where the autotuned motor constants are to be stored. 1: Motor 1 2: Motor 2	1 or 2	1	No	Yes	Yes	Yes	Yes	Yes	700H	4-12
	Select Motor											
T1-01	Autotuning mode selection	Set the autotuning mode. 0: Rotational autotuning 1: Stationary autotuning 2: Stationary autotuning for line-to-line resistance only	0 to 2 *1	0	No	Yes	Yes	Yes	Yes	Yes	701H	4-9 4-12
	Tuning Mode Sel											
T1-02	Motor output power	Set the output power of the motor in kilowatts.	0.00 to 650.00	0.40 kW	No	Yes	Yes	Yes	Yes	Yes	702H	4-12
	Mtr Rated Power											
T1-03	Motor rated voltage	Set the rated voltage of the motor in volts.	0 to 255.0*2	200.0 V *2	No	No	No	Yes	Yes	Yes	703H	4-12
	Rated Voltage											
T1-04	Motor rated current	Set the rated current of the motor in amps.	0.32 to 6.40 *4	1.90 A *3	No	Yes	Yes	Yes	Yes	Yes	704H	4-12
	Rated Current											
T1-05	Motor base frequency	Set the base frequency of the motor in hertz.	0 to 400.0*5	60.00 Hz	No	No	No	Yes	Yes	Yes	705H	4-12
	Rated Frequency											
T1-06	Number of motor poles	Set the number of motor poles.	2 to 48 poles	4 poles	No	No	No	Yes	Yes	Yes	706H	4-12
	Number of Poles											
T1-07	Motor base speed	Set the base speed of the motor in min ⁻¹ .	0 to 24000	1750 min ⁻¹	No	No	No	Yes	Yes	Yes	707H	4-13
	Rated Speed											
T1-08	Number of PG pulses when turning	Set the number of pulses per revolution for the PG being used (pulse generator or encoder) without any multiplication factor.	0 to 60000	600	No	No	Yes	No	Yes	No	708H	4-13
	PG Pulses/Rev											

* 1. Set T1-02 and T1-04 when 2 is set for T1-01. Only set value 2 is possible for V/f control or V/f control with PG.

* 2. These are values for a 200 V class Inverter. Values for a 400 V class Inverter are double.

* 3. The factory setting depends on the Inverter capacity. (The value for a 200 V Class Inverter for 0.4 kW is given.)

* 4. The setting range is from 10% to 200% of the Inverter rated output current. (The value for a 200 V Class Inverter for 0.4 kW is given.)

* 5. The upper setting limit will be 150.0 Hz when C6-01 is set to 0.

◆ U: Monitor Constants

The following settings are made with the monitor constants (U constants): Setting constants for monitoring in drive mode.

■ Status Monitor Constants: U1

The constants used for monitoring status are listed in the following table.

Constant Number	Name	Description	Output Signal Level During Multi-Function Analog Output	Min. Unit	Control Methods					MEMO BUS Register
	Display				V/f	V/f with PG	Open Loop Vector 1	Flux Vector	Open Loop Vector 2	
U1-01	Frequency reference	Monitors/sets the frequency reference value.*	10 V: Max. frequency (0 to ± 10 V possible)	0.01 Hz	A	A	A	A	A	40H
	Frequency Ref									
U1-02	Output frequency	Monitors the output frequency.*	10 V: Max. frequency (0 to ± 10 V possible)	0.01 Hz	A	A	A	A	A	41H
	Output Freq									
U1-03	Output current	Monitors the output current.	10 V: Inverter rated output current (0 to +10 V, absolute value output)	0.1 A	A	A	A	A	A	42H
	Output Current									
U1-04	Control method	Checks the current control method.	(Cannot be output.)	-	A	A	A	A	A	43H
	Control Method									
U1-05	Motor speed	Monitors the detected motor speed.*	10 V: Max. frequency (0 to ± 10 V possible)	0.01 Hz	No	A	A	A	A	44H
	Motor Speed									
U1-06	Output voltage	Monitors the output voltage reference value in the Inverter.	10 V: 200 VAC (400 VAC) (0 to +10 V output)	0.1 V	A	A	A	A	A	45H
	Output Voltage									
U1-07	DC bus voltage	Monitors the main DC voltage in the Inverter.	10 V: 400 VDC (800 VDC) (0 to +10 V output)	1 V	A	A	A	A	A	46H
	DC Bus Voltage									
U1-08	Output power	Monitors the output power (internally detected value).	10 V: Inverter capacity (max. applicable motor capacity) (0 to ± 10 V possible)	0.1 kW	A	A	A	A	A	47H
	Output kWatts									
U1-09	Torque reference	Monitor in internal torque reference value for vector control.	10 V: Motor rated torque (0 to ± 10 V possible)	0.1%	No	No	A	A	A	48H
	Torque Reference									

* The unit is set in o1-03 (frequency units of reference setting and monitor).

Constant Number	Name	Description	Output Signal Level During Multi-Function Analog Output	Min. Unit	Control Methods					MEMO BUS Register
	Display				V/f	V/f with PG	Open Loop Vector 1	Flux Vector	Open Loop Vector 2	
U1-10	Input terminal status	Shows input ON/OFF status. U1-10= 00000000 <ul style="list-style-type: none"> 1: FWD command (S1) is ON. 1: REV command (S2) is ON. 1: Multi input 1 (S3) is ON. 1: Multi input 2 (S4) is ON. 1: Multi input 3 (S5) is ON. 1: Multi input 4 (S6) is ON. 1: Multi input 5 (S7) is ON. 1: Multi input 6 (S8) is ON. 	(Cannot be output.)	-	A	A	A	A	A	49H
	Input Term Sts									
U1-11	Output terminal status	Shows output ON/OFF status. U1-11= 00000000 <ul style="list-style-type: none"> 1: Multi-function contact output 1 (M1-M2) is ON. 1: Multi-fuction contact output 2 (P1) is ON. 1: Multi-fuction contact output 3 (P2) is ON. Not used (always 0). 1: Error output (MA/AB-MC) is ON. 	(Cannot be output.)	-	A	A	A	A	A	4AH
	Output Term Sts									
U1-12	Operation status	Inverter operating status. U1-12= 00000000 <ul style="list-style-type: none"> 1: Run 1: Zero speed 1: Reverse 1: Reset signal input 1: Speed agree 1: Inverter ready 1: Minor fault 1: Major fault 	(Cannot be output.)	-	A	A	A	A	A	4BH
	Int Ctl Sts 1									
U1-13	Cumulative operation time	Monitors the total operating time of the Inverter. The initial value and the operating time/power ON time selection can be set in o2-07 and o2-08.	(Cannot be output.)	1 hr	A	A	A	A	A	4CH
	Elapsed Time									
U1-14	Software No. (flash memory)	(Manufacturer's ID number)	(Cannot be output.)	-	A	A	A	A	A	4DH
	FLASH ID									

Constant Number	Name	Description	Output Signal Level During Multi-Function Analog Output	Min. Unit	Control Methods					MEMO BUS Register
	Display				V/f	V/f with PG	Open Loop Vector 1	Flux Vector	Open Loop Vector 2	
U1-15	Terminal A1 input voltage	Monitors the input voltage of the voltage frequency reference. An input of 10 V corresponds to 100%.	10 V: 100% (10 V) (0 to ± 10 V possible)	0.1 %	A	A	A	A	A	4EH
	Term A1 Level									
U1-16	Terminal A2 input voltage	Monitors the input voltage of the multi-function analog input. An input of 10 V corresponds to 100%.	10 V: 100% (10 V) (0 to ± 10 V possible)	0.1 %	A	A	A	A	A	4FH
	Term A2 Level									
U1-17	Terminal A3 input voltage	Monitors the input voltage of the multi-function analog input. An input of 10 V corresponds to 100%.	10 V: 100% (10 V) (0 to ± 10 V possible)	0.1 %	A	A	A	A	A	050H
	Term 16 Level									
U1-18	Motor secondary current (Iq)	Monitors the calculated value of the motor secondary current. The motor rated secondary current corresponds to 100%.	10 V: Motor rated secondary current) (0 to ± 10 V output)	0.1 %	A	A	A	A	A	51H
	Mot SEC Current									
U1-19	Motor exciting current (Id)	Monitors the calculated value of the motor excitation current. The motor rated secondary current corresponds to 100%.	10 V: Motor rated secondary current) (0 to ± 10 V output)	0.1 %	No	No	A	A	A	52H
	Mot EXC Current									
U1-20	Output frequency after soft-start	Monitors the output frequency after a soft start. The frequency given does not include compensations, such as slip compensation. The unit is set in o1-03.	10 V: Max. frequency (0 to ± 10 V possible)	0.0 1Hz	A	A	A	A	A	53H
	SFS Output									
U1-21	ASR input	Monitors the input to the speed control loop. The maximum frequency corresponds to 100%.	10 V: Max. frequency (0 to ± 10 V possible)	0.0 1%	No	A	No	A	A	54H
	ASR Input									
U1-22	ASR output	Monitors the output from the speed control loop. The motor rated secondary current corresponds to 100%.	10 V: Motor rated secondary current) (0 to ± 10 V possible)	0.0 1%	No	A	No	A	A	55H
	ASR Output									
U1-24	PID feedback value	Monitors the feedback value when PID control is used. The input for the max. frequency corresponds to 100%.	10 V: Max. frequency (0 to ± 10 V possible)	0.0 1%	A	A	A	A	A	57H
	PID Feedback									
U1-25	DI-16H2 input status	Monitors the reference value from a DI-16H2 Digital Reference Card. The value will be displayed in binary or BCD depending on user constant F3-01.	(Cannot be output.)	-	A	A	A	A	A	58H
	DI-16 Reference									

Constant Number	Name	Description	Output Signal Level During Multi-Function Analog Output	Min. Unit	Control Methods					MEMO BUS Register
	Display				V/f	V/f with PG	Open Loop Vector 1	Flux Vector	Open Loop Vector 2	
U1-26	Output voltage reference (Vq)	Monitors the Inverter internal voltage reference for motor secondary current control.	10 V: 200 VAC (400 VAC) (0 to ± 10 V possible)	0.1 V	No	No	A	A	A	59H
	Voltage Ref (Vq)									
U1-27	Output voltage reference (Vd)	Monitors the Inverter internal voltage reference for motor excitation current control.	10 V: 200 VAC (400 VAC) (0 to ± 10 V possible)	0.1 V	No	No	A	A	A	5AH
	Voltage Ref (Vd)									
U1-28	Software No. (CPU)	(Manufacturer's CPU software No.)	(Cannot be output.)	-	A	A	A	A	A	5BH
	CPU ID									
U1-32	ACR output of q axis	Monitors the current control output value for the motor secondary current.	10 V: 100% (0 to ± 10 V possible)	0.1 %	No	No	A	A	A	5FH
	ACR(q) Output									
U1-33	ACR output of d axis	Monitors the current control output value for the motor excitation current.	10 V: 100% (0 to ± 10 V possible)	0.1 %	No	No	A	A	A	60H
	ACR(d) Output									
U1-34	OPE fault constant	Shows the first constant number where an OPE fault was detected.	(Cannot be output.)	-	A	A	A	A	A	61H
	OPE Detected									
U1-35	Zero servo movement pulses	Shows the number of PG pulses times 4 for the movement range when stopped at zero.	(Cannot be output.)	1	No	No	No	A	No	62H
	Zero Servo Pulse									
U1-36	PID input volume	PID feedback volume Given as maximum frequency/ 100%	10 V: Max. frequency (0 to ± 10 V possible)	0.0 1%	A	A	A	A	A	63H
	PID Input									
U1-37	PID output volume	PID control output Given as maximum frequency/ 100%	10 V: Max. frequency (0 to ± 10 V possible)	0.0 1%	A	A	A	A	A	64H
	PID Output									
U1-38	PID command	PID command + PID command bias Given as maximum frequency/ 100%	10 V: Max. frequency	0.0 1%	A	A	A	A	A	65H
	PID Set-point									
U1-39	MEMO-BUS communications error code	Shows MEMOBUS errors. U1-40= 00000000 <ul style="list-style-type: none"> 1: CRC error 1: Data length error Not used (always 0). 1: Parity error 1: Overrun error 1: Framing error 1: Timeout Not used (always 0). 	(Cannot be output.)	-	A	A	A	A	A	66H
	Transmit Err									

Constant Number	Name	Description	Output Signal Level During Multi-Function Analog Output	Min. Unit	Control Methods					MEMO BUS Register
	Display				V/f	V/f with PG	Open Loop Vector 1	Flux Vector	Open Loop Vector 2	
U1-40	Cooling fan operating time	Monitors the total operating time of the cooling fan. The time can be set in 02-10.	(Cannot be output.)	1 hr	A	A	A	A	A	68H
	FAN Elapsed Time									
U1-42	Estimated motor flux	Monitors the calculated value of the motor flux. 100% is displayed for the rated motor flux.	10 V: Rated motor flux	0.1 %	No	No	No	No	A	69H
	Mot Flux EST									
U1-43	Motor flux current compensation	Monitors motor flux current compensation value. 100% is displayed for the rated secondary current of the motor.	10 V: Rated secondary current of motor (-10 V to 10 V)	0.1 %	No	No	No	No	A	6AH
	Id Comp Value									
U1-44	ASR output without filter	Monitors the output from the speed control loop (i.e., the primary filter input value). 100% is displayed for rated secondary current of the motor.	10 V: Rated secondary current of motor (-10 V to 10 V)	0.01 %	No	No	No	A	A	6BH
	ASR Output w Fil									
U1-45	Feed forward control output	Monitors the output from feed forward control. 100% is displayed for rated secondary current of the motor.	10 V: Rated secondary current of motor (-10 V to 10 V)	0.01 %	No	No	No	A	A	6CH
	FF Cout Output									

■ Fault Trace: U2

User constants for error tracing are shown in the following table.

Constant Number	Name	Description	Output Signal Level During Multi-Function Analog Output	Min. Unit	Control Methods					MEMO BUS Register																																																																								
	Display				V/f	V/f with PG	Open Loop Vector 1	Flux Vector	Open Loop Vector 2																																																																									
U2-01	Current fault	The contents of the current fault.	(Cannot be output.)	-	A	A	A	A	A	80H																																																																								
	Current Fault																																																																																	
U2-02	Previous fault	The contents of the error that occurred just prior to the current fault.									(Cannot be output.)	-	A	A	A	A	A	81H																																																																
	Last Fault																																																																																	
U2-03	Reference frequency at fault	The reference frequency when the previous fault occurred.																	(Cannot be output.)	0.01 Hz	A	A	A	A	A	82H																																																								
	Frequency Ref																																																																																	
U2-04	Output frequency at fault	The output frequency when the previous fault occurred.																									(Cannot be output.)	0.01 Hz	A	A	A	A	A	83H																																																
	Output Freq																																																																																	
U2-05	Output current at fault	The output current when the previous fault occurred.																																	(Cannot be output.)	0.1 A	A	A	A	A	A	84H																																								
	Output Current																																																																																	
U2-06	Motor speed at fault	The motor speed when the previous fault occurred.																																									(Cannot be output.)	0.01 Hz	No	A	A	A	A	85H																																
	Motor Speed																																																																																	
U2-07	Output voltage reference at fault	The output reference voltage when the previous fault occurred.																																																	(Cannot be output.)	0.1 V	A	A	A	A	A	86H																								
	Output Voltage																																																																																	
U2-08	DC bus voltage at fault	The main current DC voltage when the previous fault occurred.																																																									(Cannot be output.)	1 V	A	A	A	A	A	87H																
	DC Bus Voltage																																																																																	
U2-09	Output power at fault	The output power when the previous fault occurred.																																																																	(Cannot be output.)	0.1 kW	A	A	A	A	A	88H								
	Output kWatts																																																																																	
U2-10	Torque reference at fault	The reference torque when the previous fault occurred. The motor rated torque corresponds to 100%.																																																																									(Cannot be output.)	0.1%	No	No	A	No	A	89H
	Torque Reference																																																																																	

Con- stant Number	Name	Description	Output Signal Level During Multi-Function Analog Output	Min. Unit	Control Methods					MEMO BUS Regis- ter	
	Display				V/f	V/f with PG	Open Loop Vec- tor 1	Flux Vec- tor	Open Loop Vec- tor 2		
U2-11	Input termi- nal status at fault	The input terminal status when the previous fault occurred. The format is the same as for U1- 10.	(Cannot be output.)	-	A	A	A	A	A	8AH	
	Input Term Sts										
U2-12	Output termi- nal status at fault	The output terminal status when the previous fault occurred. The format is the same as for U1-11.		-	A	A	A	A	A	A	8BH
	Output Term Sts										
U2-13	Operation status at fault	The operating status when the previous fault occurred. The for- mat is the same as for U1-12.		-	A	A	A	A	A	A	8CH
	Inverter Sta- tus										
U2-14	Cumulative operation time at fault	The operating time when the pre- vious fault occurred.		1 hr	A	A	A	A	A	A	8DH
	Elapsed time										

Note The following errors are not included in the error trace: CPF00, 01, 02, 03, UV1, and UV2.

■ Fault History: U3

User constants for the error log are shown in the following table.

Con- stant Number	Name	Description	Output Signal Level During Multi-Function Analog Output	Min. Unit	Control Methods					MEMO BUS Regis- ter		
	Display				V/f	V/f with PG	Open Loop Vec- tor 1	Flux Vec- tor	Open- loop Vec- tor 2			
U3-01	Most recent fault	The error contents of 1st previous fault.	(Cannot be output.)	-	A	A	A	A	A	A	90H	
	Last Fault											
U3-02	Second most recent fault	The error contents of 2nd previous fault.		-	A	A	A	A	A	A	A	91H
	Fault Mes- sage 2											
U3-03	Third most recent fault	The error contents of 3rd previous fault.		-	A	A	A	A	A	A	A	92H
	Fault Mes- sage 3											
U3-04	Fourth/oldest fault	The error contents of 4th previous fault.		-	A	A	A	A	A	A	A	93H
	Fault Mes- sage 4											
U3-05	Cumulative operation time at fault	The total operating time when the 1st previous fault occurred.		1 hr	A	A	A	A	A	A	A	94H
	Elapsed Time 1											
U3-06	Accumulated time of sec- ond fault	The total operating time when the 2nd previous fault occurred.		1 hr	A	A	A	A	A	A	A	95H
	Elapsed Time 2											
U3-07	Accumulated time of third fault	The total operating time when the 3rd previous fault occurred.		1 hr	A	A	A	A	A	A	A	96H
	Elapsed Time 3											
U3-08	Accumulated time of fourth/oldest fault	The total operating time when the 4th previous fault occurred.		1 hr	A	A	A	A	A	A	A	97H
	Elapsed Time 4											

Note The following errors are not recorded in the error log: CPF00, 01, 02, 03, UV1, and UV2.

◆ Factory Settings that Change with the Control Method (A1-02)

The factory settings of the following user constants will change if the control method (A1-02) is changed.

Constant Number	Name	Setting Range	Unit	Factory Setting				
	Display			V/f Control	V/f with PG	Open-loop Vector 1	Flux Vector	Open Loop Vector 2
b3-01	Speed search selection	0 to 3	1	2	3	2	-	2
	SpdSrCh at Start							
b3-02	Speed search operating current	0 to 200	1%	120	-	100	-	10
	SpdSrCh Current							
b8-02	Energy-saving gain	0.0 to 10.0	0.1	-	-	0.7	1.0	0.7
	Energy Save Gain							
b8-03	Energy-saving filter time constant	0.0 to 10.00	0.01 s	-	-	0.50	0.01	0.50
	Energy Save F.T							
C3-01	Slip compensation gain	0.0 to 2.5	0.1	0.0	-	1.0	1.0	1.0
	Slip Comp Gain							
C3-02	Slip compensation primary delay time	0 to 10000	1 ms	2000	-	200	-	-
	Slip Comp Time							
C4-02	Torque compensation primary delay time constant	0 to 10000	1 ms	200	200	20	-	-
	Torq Comp Time							
C5-01	ASR proportional (P) gain 1	0.00 to 300.00	0.01	-	0.20	-	20.00	10.00
	ASR P Gain 1							
C5-02	ASR integral (I) time	0.000 to 10.000	0.001 s	-	0.200	-	0.500	0.500
	ASR I Time 1							
C5-03	ASR proportional (P) gain 2	0.00 to 300.00	0.01	-	0.02	-	20.00	10.00
	ASR P Gain 2							
C5-04	ASR integral (I) time 2	0.000 to 10.000	0.001 sec.	-	0.050	-	0.500	0.500
	ASR I Time 2							
C5-06	ASR primary delay time	0.000 to 0.500	0.001	-	-	-	0.004	0.010
	ASR Delay Time							
d5-02	Torque reference delay time	0 to 1000	1 ms	-	-	-	0	10
	Torq Ref Filter							
E1-04 E3-02	Max. output frequency (FMAX) Max Frequency	0.0 to 400.0	0.1 Hz	60.0 *3	60.0 *3	60.0	60.0	60.0
E1-05 E3-03	Max. voltage (VMAX) Max Voltage							
E1-06 E3-04	Base frequency (FA) Base Frequency	0.0 to 400.0	0.1 Hz	60.0 *3	60.0 *3	60.0	60.0	60.0
E1-07 E3-05	Mid. output frequency (FB) Mid Frequency A							
E1-08 E3-06	Mid. output frequency voltage (VC) ^{*2} Mid Voltage A	0.0 to 255.0 (0.0 to 510.0)	0.1 V	15.0 *3	15.0 *3	11.0	0.0	0.0

■ 200 V Class Inverters of 55 to 110 kW and 400 V Class Inverters of 55 to 300 kW

Con- stant Num- ber	Unit	Factory Setting															Open Loop Vector Con- trol 1	Open Loop Vector Con- trol 2	Flux Vector Con- trol	
		0	1	2	3	4	5	6	7	8	9	A	B	C	D	E				F
E1-03	-																			
E1-04	Hz	50.0	60.0	60.0	72.0	50.0	50.0	60.0	60.0	50.0	50.0	60.0	60.0	90.0	120.0	180.0	60.0	60.0	60.0	
E1-05*	V	200.0	200.0	200.0	200.0	200.0	200.0	200.0	200.0	200.0	200.0	200.0	200.0	200.0	200.0	200.0	200.0	200.0	200.0	
E1-06	Hz	50.0	60.0	50.0	60.0	50.0	50.0	60.0	60.0	50.0	50.0	60.0	60.0	60.0	60.0	60.0	60.0	60.0	0.0	
E1-07	Hz	2.5	3.0	3.0	3.0	25.0	25.0	30.0	30.0	2.5	2.5	3.0	3.0	3.0	3.0	3.0	3.0	3.0	0.0	
E1-08*	V	12.0	12.0	12.0	12.0	35.0	50.0	35.0	50.0	15.0	20.0	15.0	20.0	12.0	12.0	12.0	12.0	11.0	13.3	
E1-09	Hz	1.3	1.5	1.5	1.5	1.3	1.3	1.5	1.5	1.3	1.3	1.5	1.5	1.5	1.5	1.5	1.5	0.5	0.3	
E1-10*	V	6.0	6.0	6.0	6.0	5.0	6.0	5.0	6.0	7.0	9.0	7.0	11.0	6.0	6.0	6.0	6.0	2.0	1.3	

* The setting shown are for 200 V class Inverters. The values will double for 400 V class Inverters.

◆ Factory Settings that Change with the Inverter Capacity (o2-04)

The factory settings of the following user constants will change if the Inverter capacity (o2-04) is changed.

■ 200 V Class Inverters

Constant Number	Name	Unit	Factory Setting								
			0.4	0.75	1.5	2.2	3.7	5.5	7.5	11	15
-	Inverter Capacity	kW	0.4	0.75	1.5	2.2	3.7	5.5	7.5	11	15
o2-04	kVA selection	-	0	1	2	3	4	5	6	7	8
b8-03	Energy-saving filter time constant	s	0.50 (Open-loop vector control)								
b8-04	Energy-saving coefficient	-	288.20	223.70	169.40	156.80	122.90	94.75	72.69	70.44	63.13
C6-02	Carrier frequency selection*1	-	6	6	6	6	6	6	6	6	6
C6-11	Carrier frequency selection for open-loop vector control*2	-	3	3	3	3	3	3	3	3	3
-	Carrier frequency selection upper limit	-	6	6	6	6	6	6	6	6	6
E2-01 (E4-01)	Motor rated current	A	1.90	3.30	6.20	8.50	14.00	19.60	26.60	39.7	53.0
E2-02 (E4-02)	Motor rated slip	Hz	2.90	2.50	2.60	2.90	2.73	1.50	1.30	1.70	1.60
E2-03 (E4-03)	Motor no-load current	A	1.20	1.80	2.80	3.00	4.50	5.10	8.00	11.2	15.2
E2-05 (E4-05)	Motor line-to-line resistance	Ω	9.842	5.156	1.997	1.601	0.771	0.399	0.288	0.230	0.138
E2-06 (E4-06)	Motor leak inductance	%	18.2	13.8	18.5	18.4	19.6	18.2	15.5	19.5	17.2
E2-10	Motor iron loss for torque compensation	W	14	26	53	77	112	172	262	245	272
L2-02	Momentary power loss ride-thru time	s	0.1	0.2	0.3	0.5	1.0	1.0	1.0	2.0	2.0
L2-03	Min. baseblock (BB) time	s	0.2	0.3	0.4	0.5	0.6	0.7	0.8	0.9	1.0
L2-04	Voltage recovery time	s	0.3	0.3	0.3	0.3	0.3	0.3	0.3	0.3	0.6
L8-02	Overheat pre-alarm level	°C	95	95	100	95	95	95	95	90	100
N5-02	Motor acceleration time	s	0.178	0.142	0.166	0.145	0.154	0.168	0.175	0.265	0.244

Constant Number	Name	Unit	Factory Setting									
			18.5	22	30	37	45	55	75	90	110	
-	Inverter Capacity	kW	18.5	22	30	37	45	55	75	90	110	
o2-04	kVA selection	-	9	A	B	C	D	E	F	10	11	
b8-03	Energy-saving filter time constant	s	0.50 (Open-loop vector control)					2.00 (Open-loop vector control)				
b8-04	Energy-saving coefficient	-	57.87	51.79	46.27	38.16	35.78	31.35	23.10	20.65	18.12	
C6-02	Carrier frequency selection	-	6	4	4	4	4	4	4	1	1	
C6-11	Carrier frequency selection for open-loop vector control 2*2	-	3	3	3	3	3	3	3	1	1	
-	Carrier frequency selection upper limit	-	6	6	4	4	4	4	4	1	1	
E2-01 (E4-01)	Motor rated current	A	65.8	77.2	105.0	131.0	160.0	190.0	260.0	260.0	260.0	
E2-02 (E4-02)	Motor rated slip	Hz	1.67	1.70	1.80	1.33	1.60	1.43	1.39	1.39	1.39	
E2-03 (E4-03)	Motor no-load current	A	15.7	18.5	21.9	38.2	44.0	45.6	72.0	72.0	72.0	
E2-05 (E4-05)	Motor line-to-line resistance	Ω	0.101	0.079	0.064	0.039	0.030	0.022	0.023	0.023	0.023	
E2-06 (E4-06)	Motor leak inductance	%	20.1	19.5	20.8	18.8	20.2	20.5	20.0	20.0	20.0	
E2-10	Motor iron loss for torque compensation	W	505	538	699	823	852	960	1200	1200	1200	
L2-02	Momentary power loss ride-thru time	s	2.0	2.0	2.0	2.0	2.0	2.0	2.0	2.0	2.0	
L2-03	Min. baseblock (BB) time	s	1.0	1.1	1.1	1.2	1.2	1.3	1.5	1.7	1.7	
L2-04	Voltage recovery time	s	0.6	0.6	0.6	0.6	1.0	1.0	1.0	1.0	1.0	
L8-02	Overheat pre-alarm level	°C	90	90	95	100	100	110	100	95	95	
N5-02	Motor acceleration time	s	0.317	0.355	0.323	0.320	0.387	0.317	0.533	0.592	0.646	

Note Attach a Momentary Power Interruption Compensation Unit if compensation for power interruptions of up to 2.0 seconds is required for 200 V class Inverters with outputs of 0.4 to 7.5 kW.

- * 1. The initial settings for C6-02 are as follows: 0: Low noise PWM, 1: 2.0 kHz, 2: 5.0 kHz, 3: 8.0 kHz, 4: 10 kHz, 5: 12.5 kHz, and 6: 15 kHz. If the carrier frequency is set higher than the factory setting for Inverters with outputs of 5.5 kW or more, the Inverter rated current will need to be reduced.
- * 2. The initial settings for C6-11 are as follows: 1: 2.0 kHz, 2: 4.0 kHz, 3: 6.0 kHz, 4: 8.0 kHz.

■ 400 V Class Inverters

Constant Number	Name	Unit	Factory Setting									
			0.4	0.75	1.5	2.2	3.7	4.0	5.5	7.5	11	15
-	Inverter Capacity	kW	0.4	0.75	1.5	2.2	3.7	4.0	5.5	7.5	11	15
o2-04	kVA selection	-	20	21	22	23	24	25	26	27	28	29
b8-03	Energy-saving filter time constant	s	0.50 (Open-loop vector control)									
b8-04	Energy-saving coefficient	-	576.40	447.40	338.80	313.60	245.80	236.44	189.50	145.38	140.88	126.26
C6-02	Carrier frequency selection*1	-	3	3	3	3	3	3	3	3	3	3
C6-11	Carrier frequency selection for open-loop vector control 2*2	-	3	3	3	3	3	3	3	3	3	3
-	Carrier frequency selection upper limit	-	3	3	3	3	3	3	3	3	3	3
E2-01 (E4-01)	Motor rated current	A	1.00	1.60	3.10	4.20	7.00	7.00	9.80	13.30	19.9	26.5
E2-02 (E4-02)	Motor rated slip	Hz	2.90	2.60	2.50	3.00	2.70	2.70	1.50	1.30	1.70	1.60
E2-03 (E4-03)	Motor no-load current	A	0.60	0.80	1.40	1.50	2.30	2.30	2.60	4.00	5.6	7.6
E2-05 (E4-05)	Motor line-to-line resistance	Ω	38.198	22.459	10.100	6.495	3.333	3.333	1.595	1.152	0.922	0.550
E2-06 (E4-06)	Motor leak inductance	%	18.2	14.3	18.3	18.7	19.3	19.3	18.2	15.5	19.6	17.2
E2-10	Motor iron loss for torque compensation	W	14	26	53	77	130	130	193	263	385	440
L2-02	Momentary power loss ride-through time	s	0.1	0.2	0.3	0.5	0.5	0.8	0.8	1.0	2.0	2.0
L2-03	Min. baseblock (BB) time	s	0.2	0.3	0.4	0.5	0.6	0.6	0.7	0.8	0.9	1.0
L2-04	Voltage recovery time	s	0.3	0.3	0.3	0.3	0.3	0.3	0.3	0.3	0.3	0.6
L8-02	Overheat pre-alarm level	°C	95	95	95	95	95	95	95	90	95	95
N5-02	Motor acceleration time	s	0.178	0.142	0.166	0.145	0.154	0.154	0.168	0.175	0.265	0.244

Constant Number	Name	Unit	Factory Setting				
-	Inverter Capacity	kW	18.5	22	30	37	45
o2-04	kVA selection	-	2A	2B	2C	2D	2E
b8-03	Energy-saving filter time constant	s	0.50 (Open-loop vector control)				
b8-04	Energy-saving coefficient	-	115.74	103.58	92.54	76.32	71.56
C6-02	Carrier frequency selection*1	-	3	3	3	3	3
C6-11	Carrier frequency selection for open-loop vector control 2*2	-	3	3	3	3	3
-	Carrier frequency selection upper limit	-	3	3	3	3	3
E2-01 (E4-01)	Motor rated current	A	32.9	38.6	52.3	65.6	79.7
E2-02 (E4-02)	Motor rated slip	Hz	1.67	1.70	1.80	1.33	1.60
E2-03 (E4-03)	Motor no-load current	A	7.8	9.2	10.9	19.1	22.0
E2-05 (E4-05)	Motor line-to-line resistance	Ω	0.403	0.316	0.269	0.155	0.122
E2-06 (E4-06)	Motor leak inductance	%	20.1	23.5	20.7	18.8	19.9
E2-10	Motor iron loss for torque compensation	W	508	586	750	925	1125
L2-02	Momentary power loss ride-thru time	s	2.0	2.0	2.0	2.0	2.0
L2-03	Min. baseblock (BB) time	s	1.0	1.1	1.1	1.2	1.2
L2-04	Voltage recovery time	s	0.6	0.6	0.6	0.6	1.0
L8-02	Overheat pre-alarm level	°C	95	95	95	95	95
N5-02	Motor acceleration time	s	0.317	0.355	0.323	0.320	0.387

Constant Number	Name	Unit	Factory Setting					
			55	75	90	110	132	160
-	Inverter Capacity	kW	55	75	90	110	132	160
o2-04	kVA selection	-	2F	30	31	32	33	34
b8-03	Energy-saving filter time constant	s	2.00 (Open-loop vector control)					
b8-04	Energy-saving coefficient	-	67.20	46.20	38.91	36.23	32.79	30.13
C6-02	Carrier frequency selection ^{*1}	-	2	2	F	F	1	1
C6-11	Carrier frequency selection for open-loop vector control ^{2*2}	-	2	2	1	1	1	1
-	Carrier frequency selection upper limit	-	5.0	5.0	3.0	3.0	2.0	2.0
E2-01 (E4-01)	Motor rated current	A	95.0	130.0	156.0	190.0	223.0	270.0
E2-02 (E4-02)	Motor rated slip	Hz	1.46	1.39	1.40	1.40	1.38	1.35
E2-03 (E4-03)	Motor no-load current	A	24.0	36.0	40.0	49.0	58.0	70.0
E2-05 (E4-05)	Motor line-to-line resistance	Ω	0.088	0.092	0.056	0.046	0.035	0.029
E2-06 (E4-06)	Motor leak inductance	%	20.0	20.0	20.0	20.0	20.0	20.0
E2-10	Motor iron loss for torque compensation	W	1260	1600	1760	2150	2350	2850
L2-02	Momentary power loss ride-thru time	s	2.0	2.0	2.0	2.0	2.0	2.0
L2-03	Min. baseblock (BB) time	s	1.3	1.5	1.7	1.7	1.8	1.9
L2-04	Voltage recovery time	s	1.0	1.0	1.0	1.0	1.0	1.0
L8-02	Overheat pre-alarm level	°C	100	105	105	120	115	115
N5-02	Motor acceleration time	s	0.317	0.533	0.592	0.646	0.673	0.777

Note Inverters with a capacity of 185 kW or more are under development.

* 1. The initial settings for C6-02 are as follows: 1: 2.0 kHz, 2: 5.0 kHz, 3: 8.0 kHz, 4: 10 kHz, 5: 12.5 kHz, 6: 15 kHz, and F: User-set (Initial setting for 400-V Inverters with a capacity of 90-kW or 110-kW: 3 kHz.).

* 2. The initial settings for C6-11 are as follows: 1: 2.0 kHz, 2: 4.0 kHz, 3: 6.0 kHz, 4: 8.0 kHz.



6

Constant Settings by Function

Frequency Reference	6-2
Run Command.....	6-7
Stopping Methods	6-9
Acceleration and Deceleration Characteristics	6-15
Adjusting Frequency References.....	6-24
Speed Limit (Frequency Reference Limit Function) ..	6-30
Improved Operating Efficiency.....	6-32
Machine Protection	6-38
Continuing Operation	6-55
Inverter Protection	6-64
Input Terminal Functions.....	6-66
Monitor Constants.....	6-76
Individual Functions	6-81
Digital Operator Functions	6-132
Options	6-142

Frequency Reference

This section explains how to input the frequency reference.

◆ Selecting the Frequency Reference Source

Set constant b1-01 to select the frequency reference source.

■ Related Constants

Con-stant Number	Name	Description	Setting Range	Factory Setting	Change during Operation	Control Methods				
	Display					V/f	V/f with PG	Open-loop Vector 1	Flux Vector	Open Loop Vector 2
b1-01	Reference selection	Set the frequency reference input method. 0: Digital Operator 1: Control circuit terminal (analog input) 2: MEMOBUS communications 3: Option Card 4: Pulse train input	0 to 4	1	No	Q	Q	Q	Q	Q
	Reference Source									
H6-01	Pulse train input function selection	0: Frequency reference 1: PID feedback value 2: PID target value	0 to 2	0	No	A	A	A	A	A
	Pulse Input Sel									
H6-02	Pulse train input scaling	Set the number of pulses in hertz, taking the reference to be 100%.	1000 to 32000	1440 Hz	Yes	A	A	A	A	A
	PI Scaling									

■ Input the Reference Frequency from the Digital Operator

When b1-01 is set to 0, you can input the reference frequency from the Digital Operator.

Input the reference frequency from the Digital Operator's reference frequency setting display.

For details on setting the reference frequency, refer to *Chapter 3 Digital Operator and Modes*.

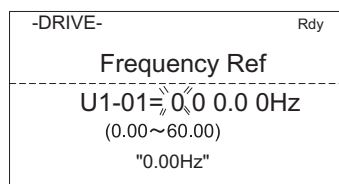

Fig 6.1 Frequency Setting Display

■ Inputting the Frequency Reference Using Voltage (Analog Setting)

When b1-01 is set to 1, you can input the frequency reference from control circuit terminal A1 (voltage input), or control circuit terminal A2 (voltage or current input).

Inputting Master Speed Frequency Reference Only

When inputting a voltage for the master speed frequency reference, input the voltage to control circuit terminal A1.

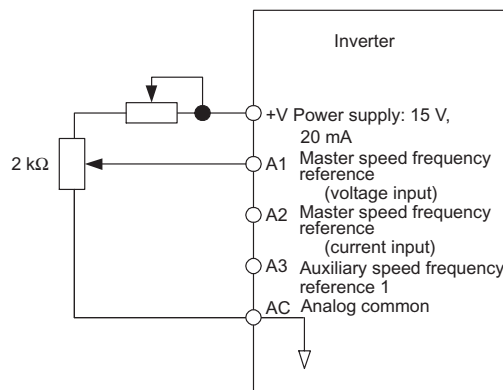

Fig 6.2 Voltage Input for Master Speed Frequency Reference

When inputting a current for the master speed frequency reference, input the current to control circuit terminal A2, input 0 V to terminal A1, set H3-08 (Multi-function analog input terminal A2 signal level selection) to 2 (current input), and set H3-09 (Multi-function analog input terminal A2 function selection) to 0 (add to terminal A1).

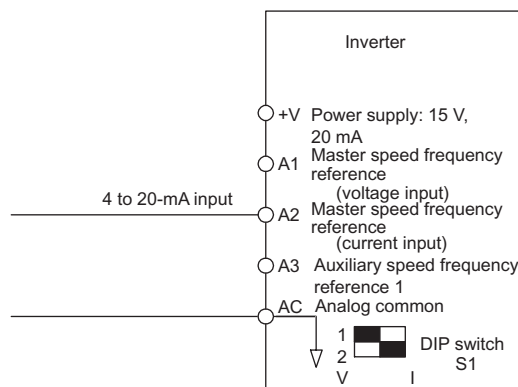

Fig 6.3 Current Input for Master Speed Frequency Reference



Turn ON pin 2 of DIP switch SW1 (toward I), the voltage/current switch, when inputting a current to terminal A2. Turn OFF pin 2 of DIP switch SW1 (toward V), the voltage/current switch, when inputting a voltage to terminal A2. Set H3-08 to the correct setting for the type of input signal being used.

Switch between 2 Step Speeds: Master/Auxiliary Speeds

When switching between the master and auxiliary speeds, connect the master speed frequency reference to control circuit terminal A1 or A2 and connect the auxiliary speed frequency reference to terminal A3. The reference on terminal A1 or A2 will be used for the Inverter frequency reference when the multi-function input allocated to multi-speed command 1 is OFF and the reference on terminal A3 will be used when it is ON. When switching between the master and auxiliary speeds, set H3-05 (Multi-function analog input terminal

A3) to 2 (auxiliary frequency reference, 2nd step analog) and set on of the multi-function input terminals to multi-step speed reference 1.

When inputting a current to terminal A2 for the master speed frequency reference, set H3-08 (Multi-function analog input terminal A2 signal level selection) to 2 (current input), and set H3-09 (Multi-function analog input terminal A2 function selection) to 0 (add to terminal A1).

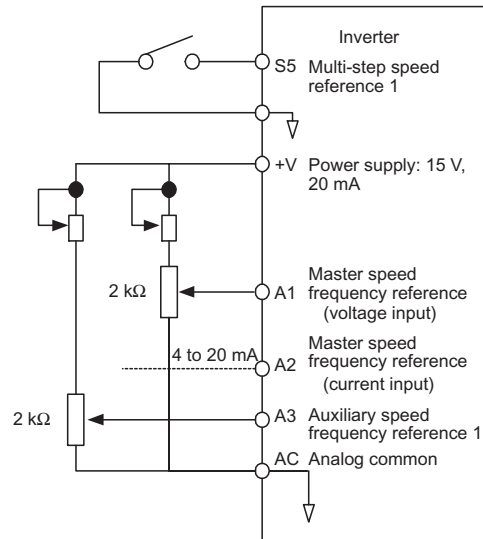

Fig 6.4 Switching between Master and Auxiliary Frequencies

■ Setting Frequency Reference Using Pulse Train Signals

When b1-01 is set to 4, the pulse train input to control circuit terminal RP is used as the frequency reference.

Set H6-01 (Pulse Train Input Function Selection) to 0 (frequency reference), and then set the 100% reference pulse frequency to H6-02 (Pulse Train Input Scaling).

Pulse Input Specifications	
Low level voltage	0.0 to 0.8 V
High level voltage	3.5 to 13.2 V
Heavy duty	30 to 70%
Pulse frequency	0 to 32 kHz

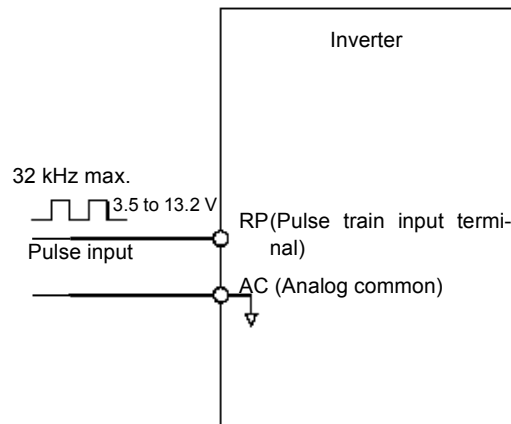

Fig 6.5 Frequency Reference Using Pulse Train Input

◆ Using Multi-Step Speed Operation

With Varispeed-G7 series Inverters, you can change the speed to a maximum of 17 steps, using 16 frequency references, and one jog frequency reference.

The following example of a multi-function input terminal function shows a 9-step operation using multi-step references 1 to 3 and jog frequency selection functions.

■ Related Constants

To switch frequency references, set multi-step speed references 1 to 3 and the jog reference selection in the multi-function contact inputs.

Multi-function Contact Inputs (H1-01 to H1-10)

Terminal	Constant Number	Set Value	Details
S5	H1-03	3	Multi-step speed reference 1 (Also used for master speed/auxiliary speed switching when multi-function analog input H3-09 is set to 2 (auxiliary frequency reference).)
S6	H1-04	4	Multi-step speed reference 2
S7	H1-05	5	Multi-step speed reference 3
S8	H1-06	6	Jog frequency selection (given priority over multi-step speed reference)

Combining Multi-Function References and Multi-Function Contact Inputs

You can change the selected frequency reference by combining the ON/OFF status of S4 to S7 (multi-function contact input terminals) to set multi-step speed references 1 to 3 and the jog frequency selection. The following table shows the possible combinations.

Speed	TerminalS5	TerminalS6	TerminalS7	TerminalS8	Selected Frequency
	Multi-step Speed Reference 1	Multi-step Speed Reference 2	Multi-step Speed Reference 3	Jog Frequency Selection	
1	OFF	OFF	OFF	OFF	Frequency reference 1 d1-01, master speed frequency
2	ON	OFF	OFF	OFF	Frequency reference 2 d1-02, auxiliary frequency 1
3	OFF	ON	OFF	OFF	Frequency reference 3 d1-03, auxiliary frequency 2
4	ON	ON	OFF	OFF	Frequency reference 4 d1-04
5	OFF	OFF	ON	OFF	Frequency reference 5 d1-05
6	ON	OFF	ON	OFF	Frequency reference 6 d1-06
7	OFF	ON	ON	OFF	Frequency reference 7 d1-07
8	ON	ON	ON	OFF	Frequency reference 8 d1-08
9	-	-	-	ON*	Jog frequency d1-17

* Terminal S8's jog frequency selection is given priority over multi-step speed references.

Setting Precautions

When setting analog inputs to step 1 to step 3, observe the following precautions.

- When setting terminal A1's analog input to step 1, set b1-01 to 1, and when setting d1-01 (Frequency Reference 1) to step 1, set b1-01 to 0.
- When setting terminal A2's analog input to step 2, set H3-09 to 2 (auxiliary frequency reference). When setting d1-02 (Frequency Reference 2) to step 2, set H3-09 to 1F (do not use analog inputs).
- When setting terminal A3's analog input to step 3, set H3-05 to 3 (auxiliary frequency reference 2). When setting d1-03(Frequency Reference 3) to step 3, set H3-05 to 1F (Analog input not used).

■ Connection Example and Time Chart

The following diagram shows a time chart and control circuit terminal connection example during a 9-step operation.

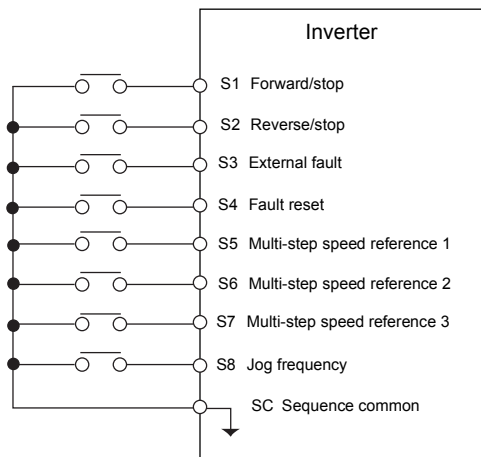

Fig 6.6 Control Circuit Terminal During 9-step Operation

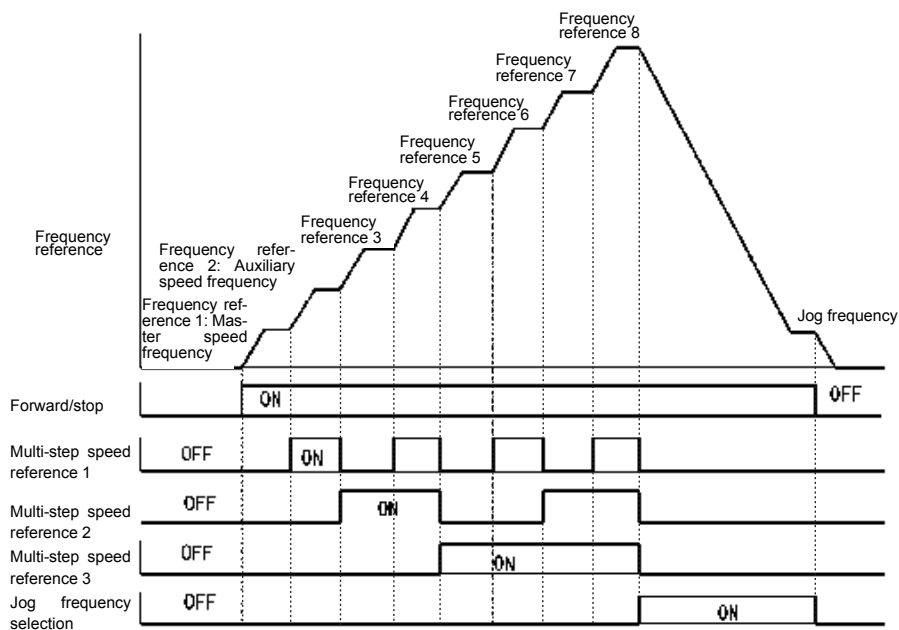

Fig 6.7 Multi-step speed reference/Jog Frequency Selection Time Chart

Run Command

This section explains input methods for the run command.

◆ Selecting the Run Command Source

Set constant b1-02 to select the source for the run command.

■ Related Constants

Constant Number	Name	Description	Setting Range	Factory Setting	Change during Operation	Control Methods				
	Display					V/f	V/f with PG	Open-loop Vector 1	Flux Vector	Open Loop Vector 2
b1-02	Operation method selection	Set the run command input method 0: Digital Operator 1: Control circuit terminal (sequence input) 2: MEMOBUS communications 3: Option Card	0 to 3	1	No	Q	Q	Q	Q	Q
	Run Source									

■ Performing Operations Using a Digital Operator

When b1-02 is set to 0, you can perform Inverter operations using the Digital Operator keys (RUN, STOP, JOG, and FWD/REV). For details on the Digital Operator, refer to *Chapter 3 Digital Operator and Modes*.

■ Performing Operations Using Control Circuit Terminals

When b1-02 is set to 1, you can perform Inverter operations using the control circuit terminals.

Performing Operations Using a 2-wire Sequence

The factory setting is set to a 2-wire sequence. When control circuit terminal S1 is set to ON, forward operation will be performed, and when S1 is turned OFF, the Inverter will stop. In the same way, when control circuit terminal S2 is set to ON, reverse operation will be performed, and when S2 is turned OFF, the Inverter will stop.

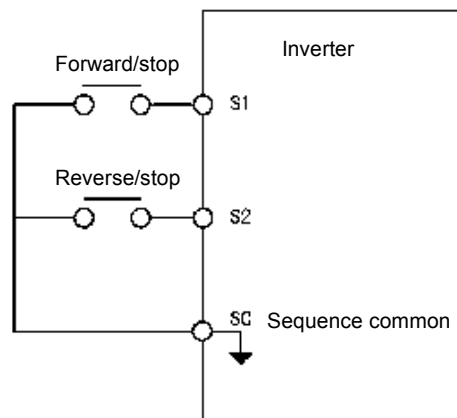

Fig 6.8 2-wire Sequence Wiring Example

Performing Operations Using a 3-wire Sequence

When any constant from H1-01 to H1-10 (multi-function contact input terminals S3 to S12) is set to 0, terminals S1 and S2 are used for a 3-wire sequence, and the multi-function input terminal that has been set functions as a forward/reverse run command terminal.

When the Inverter is initialized for 3-wire sequence control with A1-03, multi-function input 3 becomes the input terminal for the forward/reverse run command.

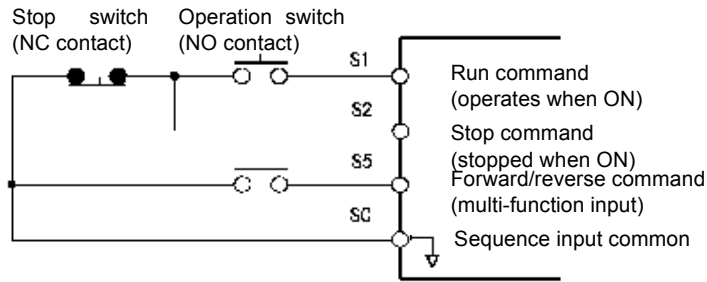

Fig 6.9 3-wire Sequence Wiring Example

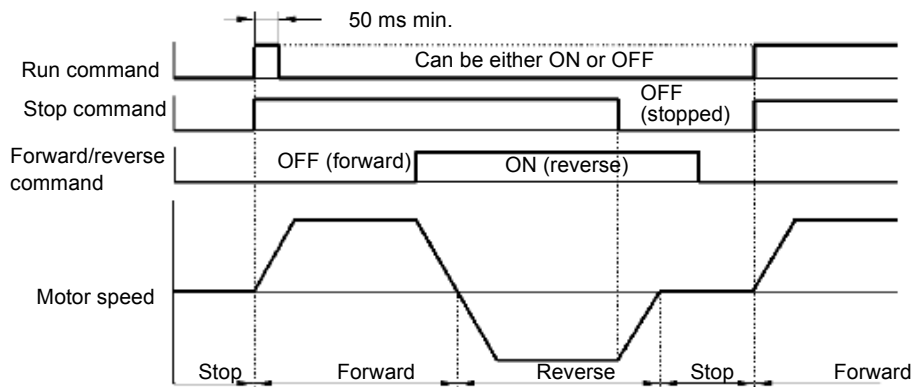

Fig 6.10 Three-wire Sequence Time Chart



INFO

Use a sequence that turns ON terminal S1 for 50 ms or longer for the run command. This will make the run command self-holding in the Inverter.

Stopping Methods

This section explains methods of stopping the Inverter.

◆ Selecting the Stopping Method when a Stop Command is Sent

There are four methods of stopping the Inverter when a stop command is sent:

- Deceleration to stop
- Coast to stop
- DC braking stop
- Coast to stop with timer

Set constant b1-03 to select the Inverter stopping method. A DC braking stop and coasting to a stop with a timer cannot be set for flux vector control.

■ Related Constants

Con- stant Number	Name	Description	Setting Range	Factory Setting	Change during Opera- tion	Control Methods				
	Display					V/f	V/f with PG	Open- loop Vec- tor 1	Flux Vec- tor	Open Loop Vec- tor 2
b1-03	Stopping method selection	Select stopping method when stop com- mand is sent. 0: Deceleration to stop 1: Coast to stop 2: DC injection braking stop (Stops faster than coast to stop, no regenerative operation.) 3: Coast to stop with timer (Run commands are disregarded during deceleration.)	0 to 3*	0	No	Q	Q	Q	Q	Q
	Stopping Method									
b1-05	Operation selection for setting E1-09 or less	Used to set the method of operation when the frequency reference input is less than the minimum output frequency (E1-09). 0: Run at frequency reference (E1-09 not effective). 1: STOP (Frequencies below E1-09 in the coast to stop state.) 2: Run at min. frequency. (E1-09) 3: Run at zero speed (Frequencies below E1-09 are zero)	0 to 3	0	No	No	No	No	A	No
	Zero-Speed Oper									
b2-01	Zero speed level (DC injection braking starting fre- quency)	Used to set the frequency which starts DC injection braking in units of Hz when deceleration to stop is selected. When b2-01 is less than E1-09, E1-09 becomes the DC injection braking start- ing frequency.	0.0 to 10.0	0.5 Hz	No	A	A	A	A	A
	DCInj Start Freq									
b2-02	DC injec- tion brak- ing current	Sets the DC injection braking current as a percentage of the Inverter rated current.	0 to 100	50%	No	A	A	A	No	No
	DCInj Cur- rent									

Constant Number	Name	Description	Setting Range	Factory Setting	Change during Operation	Control Methods				
	Display					V/f	V/f with PG	Open-loop Vector 1	Flux Vector	Open Loop Vector 2
b2-03	DC injection braking time at start	Used to set the time to perform DC injection braking at start in units of 1 second. Used to stop coasting motor and restart it. When the set value is 0, DC injection braking at start is not performed.	0.00 to 10.00	0.00 s	No	A	A	A	A	A
	DCInj Time@Start									
b2-04	DC injection braking time at stop	Used to set the time to perform DC injection braking at stop in units of 1 second. Used to prevent coasting after the stop command is input. When the set value is 0.00, DC injection braking at stop is not performed.	0.00 to 10.00	0.50 s	No	A	A	A	A	A
	DCInj Time@Stop									

* The setting range is 0 or 1 for flux vector control and open-loop vector control 2.

■ Deceleration to Stop

If the stop command is input (i.e., the run command is turned OFF) when b1-03 is set to 0, the motor decelerates to a stop according to the deceleration time that has been set. (Factory setting: C1-02 (Deceleration Time 1))

If the output frequency when decelerating to a stop falls below b2-01, the DC injection brake will be applied using the DC current set in b2-02 only for the time set in b2-04.

For deceleration time settings, refer to *page 6-16 Setting Acceleration and Deceleration Times*.

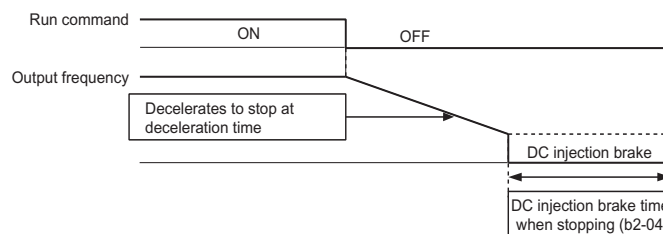

Fig 6.11 Deceleration to Stop

The operation after stopping depends on the setting of b1-05 when flux vector control is selected (A1-02 = 3).

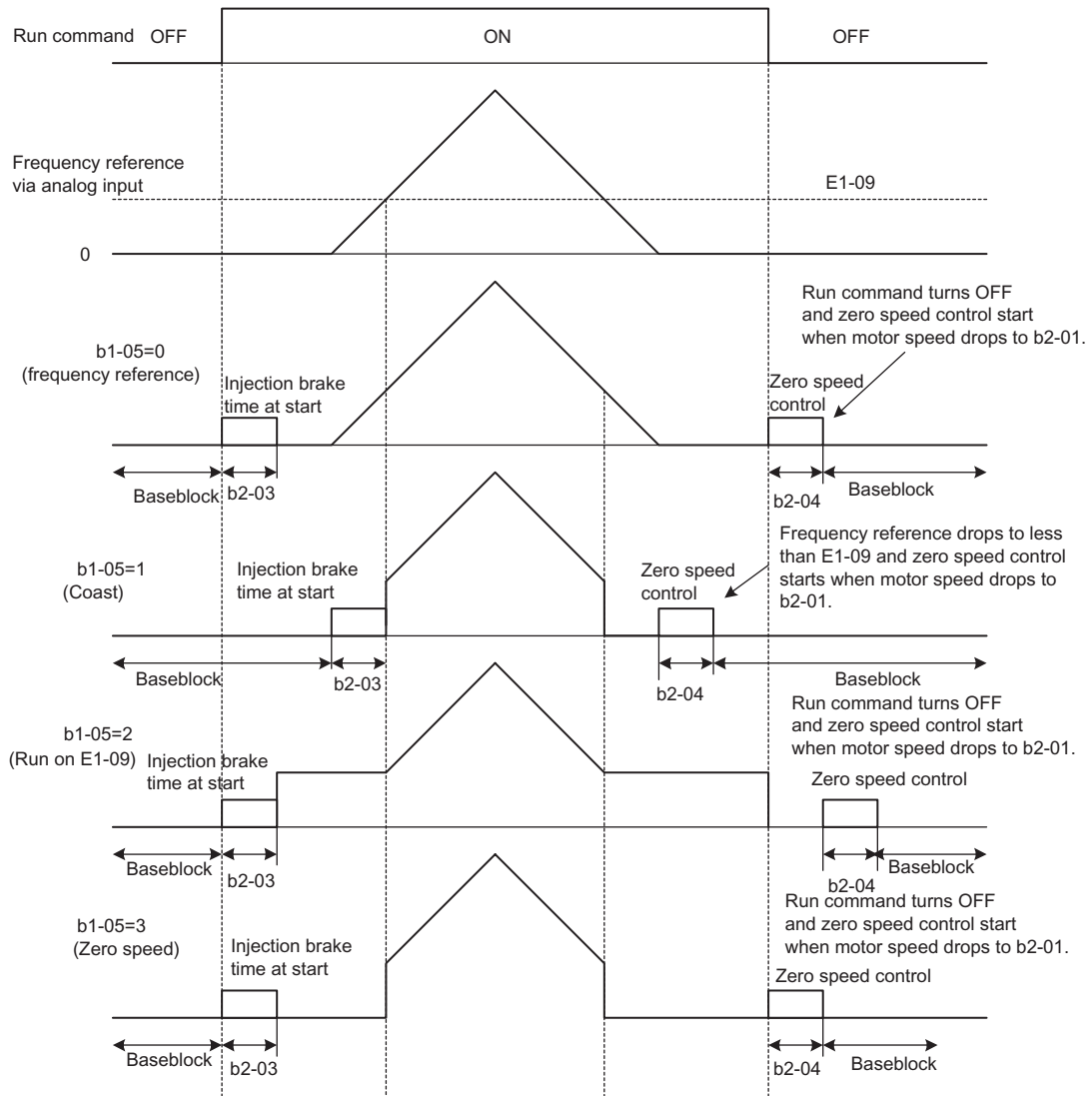

Fig 6.12 Deceleration to Stop (for Flux Vector Control)

Coast to Stop

If the stop command is input (i.e., the run command is turned OFF) when b1-03 is set to 1, the Inverter output voltage is interrupted. The motor coasts to a stop at the deceleration rate that counterbalances damage to the machine and inertia including the load.

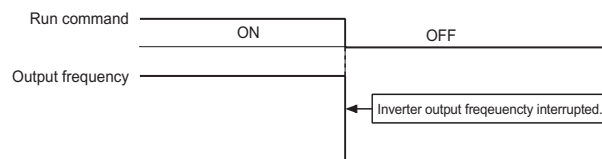

Fig 6.13 Coast to Stop



INFO

After the stop command is input, run commands are ignored until the Minimum Baseblock Time (L2-03) has elapsed.

■ DC Braking Stop

If the stop command is input (i.e., the run command is turned OFF) when b1-03 is set to 2, a wait is made for the time set in L2-03 (Minimum Baseblock (BB) Time) and then the DC injection brake current set in b2-02 is sent to the motor to apply a DC injection brake to stop the motor. The DC injection brake time is determined by the set value in b2-04 and the output frequency when the stop command is input.

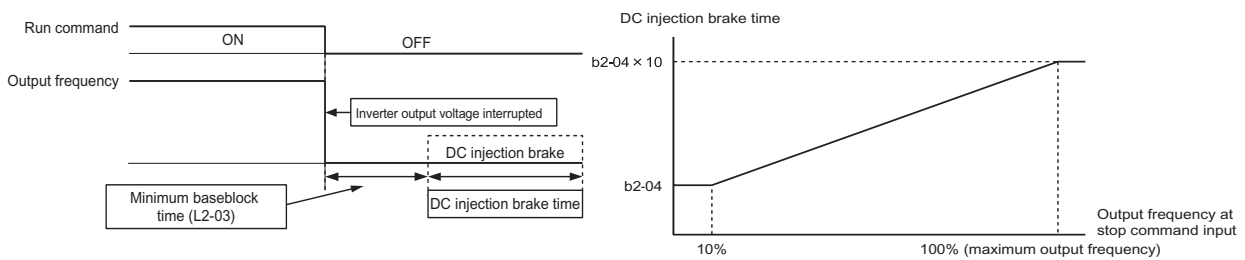

Fig 6.14 DC Injection Braking (DB) Stop



INFO

Lengthen the Minimum Baseblock Time (L2-03) when an overcurrent (OC) occurs during stopping.

■ Coast to Stop with Timer

If the stop command is input (i.e., the run command is turned OFF) when b1-03 is set to 3, the Inverter output is interrupted to coast the motor to a stop. After the stop command is input, run commands are ignored until the time T has elapsed. The time T depends upon the output frequency when the stop command is input and the deceleration time.

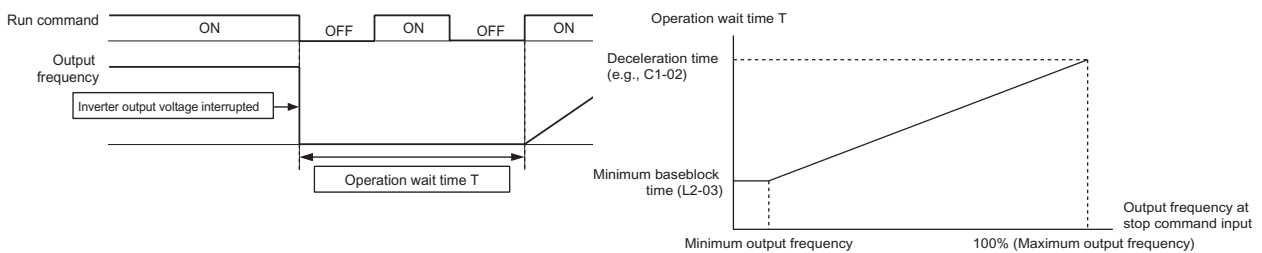

Fig 6.15 Coast to Stop with Timer

◆ Using the DC Injection Brake

Set constant b2-03 to apply the DC injection brake voltage to the motor while it is coasting to a stop, to stop the motor and then restart it.

Set b2-03 to 0 to disable the DC injection brake at start.

Set the DC injection brake current using b2-02. DC injection braking is used at startup for flux vector control with the current set in E2-03 (Motor no-load current).

■ Related Constants

Constant Number	Name	Description	Setting Range	Factory Setting	Change during Operation	Control Methods				
	Display					V/f	V/f with PG	Open Loop Vector 1	Flux Vector	Open Loop Vector 2
b2-02	DC injection braking current	Sets the DC injection braking current as a percentage of the Inverter rated current.	0 to 100	50%	No	A	A	A	No	No
	DCInj Current									
b2-03	DC injection braking time at start	Used to set the time to perform DC injection braking at start in units of 1 second.	0.00 to 10.00	0.00 s	No	A	A	A	A	A
	DCInj Time@Start	Used to stop coasting motor and restart it. When the set value is 0, DC injection braking at start is not performed.								

■ Inputting the DC Injection Brake Command from Control Circuit Terminals

If you set a multi-function contact input terminal (H1-□□) to 60 (DC injection brake command), you can apply the DC injection brake to the motor by turning ON the terminal for which the DC injection brake command has been set when the Inverter is being stopped. DC injection braking is used at startup for flux vector control.

The time chart for the DC injection brake is shown below.

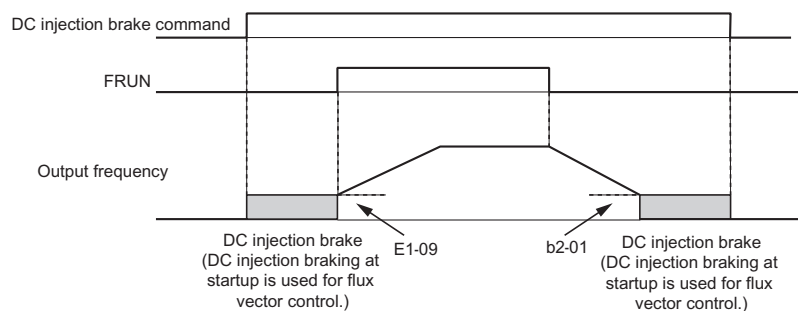

If you input the DC injection brake command from an external terminal, or if the run command and jog command are input, the DC injection brake will be disabled, and operation will resume.

Fig 6.16 DC Injection Brake Time Chart

■ Changing the DC Injection Brake Current Using an Analog Input

If you set H3-09 (Multi-function Analog Input Terminal A2 Function Selection) or H3-05 (Multi-function Analog Input Terminal A3 Function Selection) to 6 (DC injection brake current), you can change the DC injection brake current level using the analog input.

At 10 V input (voltage) or 20 mA input (current), 100% of the Inverter rated current will be applied.

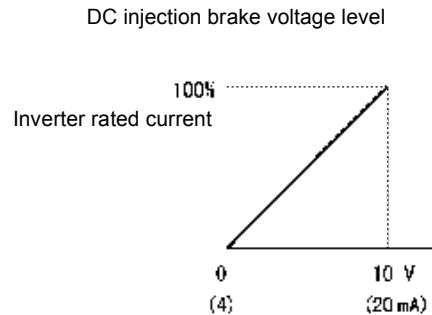

Fig 6.17 DC Injection Brake Current Using an Analog Input

◆ Using an Emergency Stop

Set a multi-function input terminal (H1-□□) to 15 or 17 (emergency stop) to decelerate to a stop at the deceleration time set in C1-09. If inputting the emergency stop with an NO contact, set the multi-function input terminal (H1-□□) to 15, and if inputting the emergency stop with an NC contact, set the multi-function input terminal (H1-□□) to 17.

After the emergency stop command has been input, operation cannot be restarted until the Inverter has stopped. To cancel the emergency stop, turn OFF the run command and emergency stop command.

■ Related parameters

Con- stant Number	Name	Description	Setting Range	Factory Setting	Change during Opera- tion	Control Methods				
	Display					V/f	V/f with PG	Open Loop Vector 1	Flux Vec- tor	Open Loop Vector 2
C1-09	Emergency stop time	The deceleration time when the multi-function input “Emergency (fast) stop” is set to ON. This function can be used a stopped method when a fault has been detected.	0.0 to 6000.0*	10.0 s	No	A	A	A	A	A
	Fast Stop Time									

* The acceleration and deceleration settings range varies depending on the setting in C1-10. When C1-10 is set to 0, the acceleration/deceleration settings range is 0.00 to 600.00 (seconds).

Acceleration and Deceleration Characteristics

This section explains the acceleration and deceleration characteristics of the Inverter.

◆ Setting Acceleration and Deceleration Times

Acceleration time indicates the time taken for the output frequency to climb from 0% to 100%. Deceleration time indicates the time taken for the output frequency to reduce to 0%. The factory setting of the acceleration time is C1-01, and the factory setting of the deceleration time is C1-02.

■ Related Parameters

Constant Number	Name	Description	Setting Range	Factory Setting	Change during Operation	Control Methods				
	Display					V/f	V/f with PG	Open Loop Vector 1	Flux Vector	Open Loop Vector 2
C1-01	Acceleration time 1	Sets the acceleration time to accelerate from 0 to the maximum output frequency, in 1-second units.	0.0 to 6000.0*	10.0 s	Yes	Q	Q	Q	Q	Q
	Accel Time 1									
C1-02	Deceleration time 1	Sets the deceleration time to decelerate from the maximum output frequency to 0, in 1-second units.			Yes	Q	Q	Q	Q	Q
	Decel Time 1									
C1-03	Acceleration time 2	The acceleration time when the multi-function input "accel/decel time 1" is set to ON.			Yes	A	A	A	A	A
	Accel Time 2									
C1-04	Deceleration time 2	The deceleration time when the multi-function input "accel/decel time 1" is set to ON.			Yes	A	A	A	A	A
	Decel Time 2									
C1-05	Acceleration time 3	The acceleration time when the multi-function input "accel/decel time 2" is set to ON.			No	A	A	A	A	A
	Accel Time 3									
C1-06	Deceleration time 3	The deceleration time when the multi-function input "accel/decel time 2" is set to ON.			No	A	A	A	A	A
	Decel Time 3									
C1-07	Acceleration time 4	The acceleration time when the multi-function input "accel/decel time 1" and "accel/decel time 2" are set to ON.			No	A	A	A	A	A
	Accel Time 4									
C1-08	Deceleration time 4	The deceleration time when the multi-function input "accel/decel time 1" and "accel/decel time 2" are set to ON.			No	A	A	A	A	A
	Decel Time 4									
C1-10	Accel/decel time setting unit	0: 0.01-second units 1: 0.1-second units	0 or 1	1	No	A	A	A	A	A
	Acc/Dec Units									

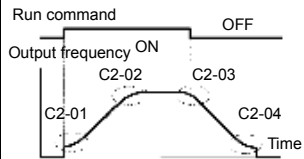
Constant Number	Name	Description	Setting Range	Factory Setting	Change during Operation	Control Methods					
	Display					V/f	V/f with PG	Open Loop Vector 1	Flux Vector	Open Loop Vector 2	
C1-11	Accel/decel time switching frequency	Sets the frequency for automatic acceleration/deceleration switching. Below set frequency: Accel/decel time 4 Above set frequency: Accel/decel time 1 The multi-function input "accel/decel time 1" or "accel/decel time 2" take priority.	0.0 to 400.0	0.0 Hz	No	A	A	A	A	A	
	Acc/Dec SW Freq										
C2-01	S-curve characteristic time at acceleration start	All sections of the S-curve characteristic time are set in seconds units. When the S-curve characteristic time is set, the accel/decel times will increase by only half of the S-curve characteristic times at start and end. 	0.00 to 2.50	0.20 s	No	A	A	A	A	A	
	SCrv Acc @ Start										
C2-02	S-curve characteristic time at acceleration end		0.00 to 2.50	0.20 s	No	A	A	A	A	A	A
	SCrv Acc @ End										
C2-03	S-curve characteristic time at deceleration start		0.00 to 2.50	0.20 s	No	A	A	A	A	A	A
	SCrv Dec @ Start										
C2-04	S-curve characteristic time at deceleration end	0.00 to 2.50	0.00 s	No	A	A	A	A	A	A	
	SCrv Dec @ End										

* The acceleration and deceleration settings range varies depending on the setting in C1-10. When C1-10 is set to 0, the acceleration/deceleration settings range is 0.00 to 600.00 (seconds).

■ Setting Acceleration and Deceleration Time Units

Set the acceleration/deceleration time units using C1-10. Constant C1-10 is set to 1 at the factory.

Set value	Details
0	The acceleration/deceleration time settings range is 0.00 to 600.00 in units of 0.01 s.
1	The acceleration/deceleration time settings range is 0.00 to 600.00 in units of 0.1 s.

■ Switching Acceleration and Deceleration Time Using Multi-Function Input Terminal Commands

Using the Inverter, you can set four acceleration times and four deceleration times. When the multi-function input terminals (H1-□□) are set to 7 (acceleration/deceleration time selection 1) and 1A (acceleration/deceleration time selection 2), you can switch the acceleration/deceleration time even during operation by combining the ON/OFF status of the terminals.

The following table shows the acceleration/deceleration time switching combinations.

Acceleration/Deceleration Time Selection 1 Terminal	Acceleration/Deceleration Time Selection 2 Terminal	Acceleration Time	Deceleration Time
OFF	OFF	C1-01	C1-02
ON	OFF	C1-03	C1-04
OFF	ON	C1-05	C1-06
ON	ON	C1-07	C1-08

■ Switching Acceleration and Deceleration Time Automatically

Use this setting when you want to switch acceleration/deceleration time automatically using the set frequency.

When the output frequency reaches the set value in C1-11, the Inverter switches the acceleration/deceleration time automatically as shown in the following diagram.

Set C1-11 to a value other than 0.0 Hz. If C1-11 is set to 0.0 Hz, the function will be disabled.

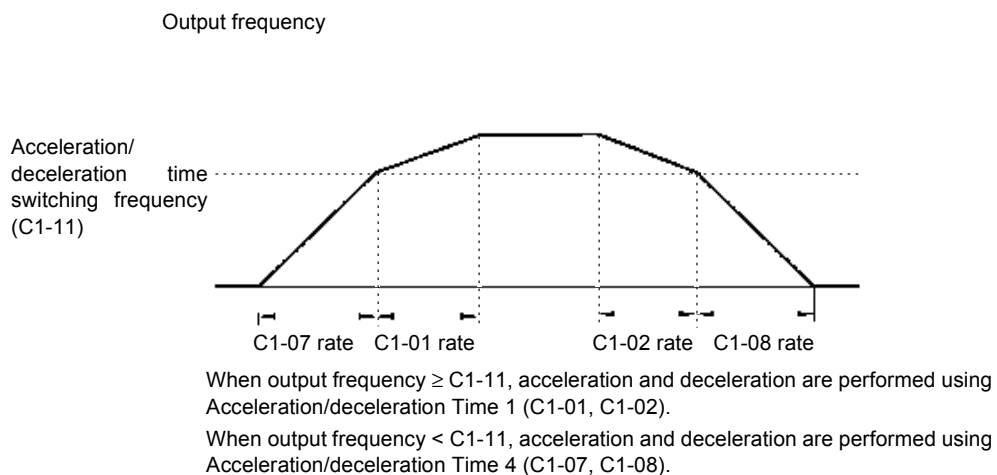

Fig 6.18 Acceleration/deceleration Time Switching Frequency

■ Adjusting Acceleration and Deceleration Time Using an Analog Input

If you set H3-09 (Multi-function Analog Input Terminal A2 Function Selection) or H3-05 (Multi-function Analog Input Terminal A3 Function Selection) to 5 (acceleration/deceleration time gain), you can adjust the acceleration/deceleration time using terminal A2's input voltage.

The Inverter's acceleration time when the acceleration time has been set in C1-01 is as follows:

Acceleration time = C1-01 set value \times acceleration/deceleration time gain

Acceleration/deceleration time gain (set value: 5)

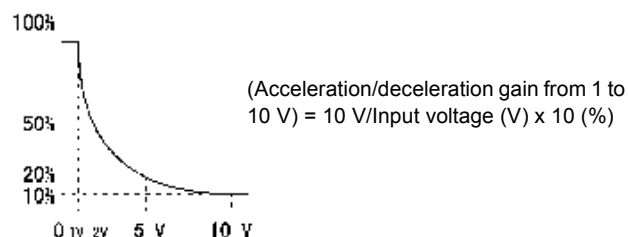

Fig 6.19 Acceleration/Deceleration Time Gain Using an Analog Input

■ Entering S-curve Characteristics in the Acceleration and Deceleration Time

By performing acceleration and deceleration using an S-curve pattern, you can reduce shock when starting and stopping the machine.

Using the Inverter, you can set an S-curve characteristic time for each of the following: Acceleration start time, deceleration start time, acceleration end time, and deceleration end time.



INFO

Set the S-curve characteristic time to lengthen acceleration/deceleration time as follows:

$$\text{Acceleration time} = \text{Selected acceleration time} + (\text{Acceleration start time S-curve characteristic time} + \text{Acceleration end time S-curve characteristic time}) / 2$$

$$\text{Deceleration time} = \text{Selected deceleration time} + (\text{Deceleration start time S-curve characteristic time} + \text{Deceleration end time S-curve characteristic time}) / 2$$

Setting Example

The S-curve characteristic when switching operation (forward/reverse) is shown in the following diagram.

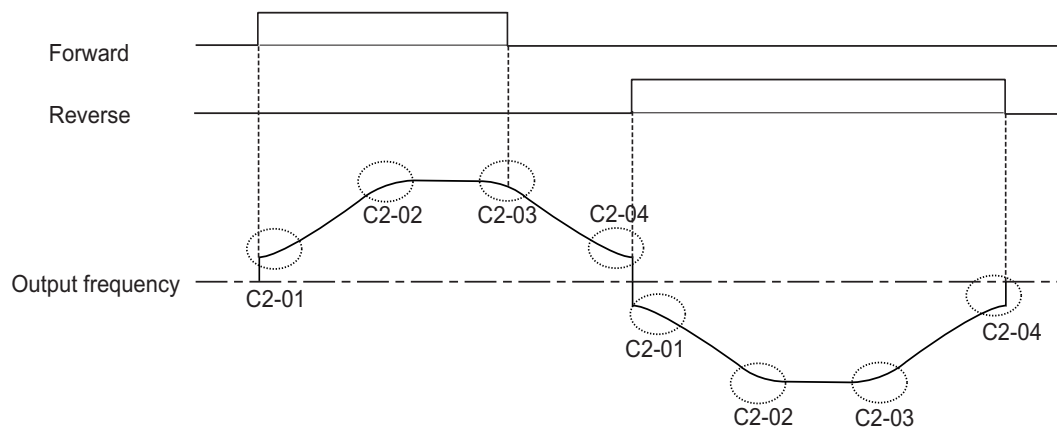
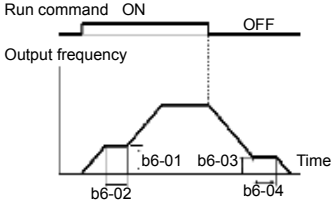

Fig 6.20 S-curve Characteristic during Operation Switching

◆ Accelerating and Decelerating Heavy Loads (Dwell Function)

The dwell function stores the output frequency when starting or stopping heavy loads. By temporarily storing the output frequency, you can prevent the motor from stalling. When using the dwell function, you must select a deceleration stop. Set b1-03 (Stopping Method Selection) to 0.

■ Related Parameters

Con- stant Number	Name	Description	Setting Range	Factory Setting	Change during Opera- tion	Control Methods					
	Display					V/f	V/f with PG	Open Loop Vector 1	Flux Vec- tor	Open Loop Vector 2	
b6-01	Dwell fre- quency at start	 <p>The dwell function is used to output frequency temporarily when driving a motor with a heavy load.</p>	0.0 to 400.0	0.0 Hz	No	A	A	A	A	A	
	Dwell Ref @Start										
b6-02	Dwell time at start		0.0 to 10.0	0.0 s	No	A	A	A	A	A	A
	Dwell Time@Start										
b6-03	Dwell fre- quency at stop		0.0 to 400.0	0.0 Hz	No	A	A	A	A	A	A
	Dwell Ref @Stop										
b6-04	Dwell time at stop		0.0 to 10.0	0.0 s	No	A	A	A	A	A	A
	Dwell Time @Stop										

◆ Preventing the Motor from Stalling During Acceleration (Stall Prevention During Acceleration Function)

The Stall Prevention During Acceleration function prevents the motor from stalling if a heavy load is placed on the motor, or sudden rapid acceleration is performed.

If you set L3-01 to 1 (enabled) and the Inverter output current exceeds the -15% level of the set value in L3-02, the acceleration rate will begin to slow down. When L3-02 is exceeded, acceleration will stop.

If you set L3-01 to 2 (optimum adjustment), the motor current accelerates to the value set in L3-02. With this setting, the acceleration time setting is ignored.

■ Related Parameters

Con-stant Number	Name	Description	Setting Range	Factory Setting	Change during Operation	Control Methods				
	Display					V/f	V/f with PG	Open Loop Vector 1	Flux Vector	Open Loop Vector 2
L3-01	Stall prevention selection during accel	0: Disabled (Acceleration as set. With a heavy load, the motor may stall.)	0 to 2	1	No	A	A	A	No	No
	StallP Accel Sel	1: Enabled (Acceleration stopped when L3-02 level is exceeded. Acceleration starts again when the current is returned.) 2: Intelligent acceleration mode (Using the L3-02 level as a basis, acceleration is automatically adjusted. Set acceleration time is disregarded.)								
L3-02	Stall prevention level during accel	Effective when L3-01 is set to 1 or 2. Set as a percentage of Inverter rated current.	0 to 200	150%	No	A	A	A	No	No
	StallP Accel Lvl	Usually setting is not necessary. The factory setting reduces the set values when the motor stalls.								
L3-03	Stall prevention limit during accel	Sets the lower limit for stall prevention during acceleration, as a percentage of the Inverter rated current, when operation is in the frequency range above E1-06.	0 to 100	50%	No	A	A	A	No	No
	StallP CHP Lvl	Usually setting is not necessary.								

Time Chart

The following figure shows the frequency characteristics when L3-01 is set to 1.

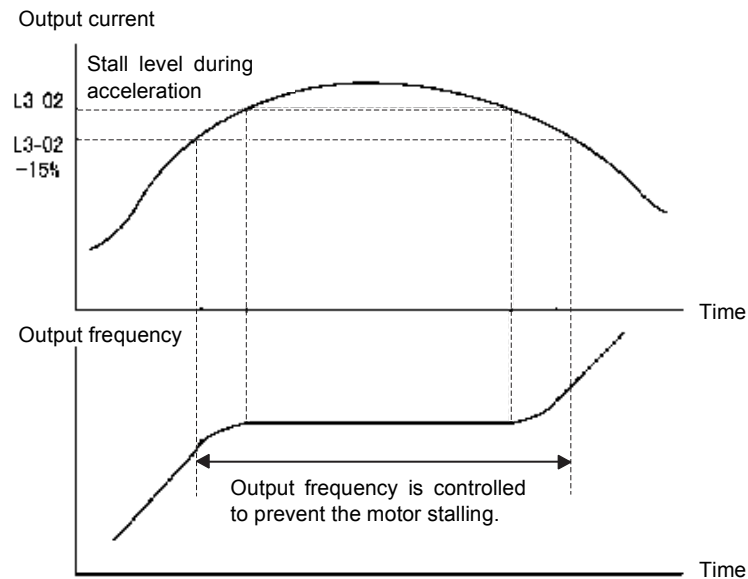

Fig 6.21 Time Chart for Stall Prevention During Acceleration

Setting Precautions

- If the motor capacity is small compared to the Inverter capacity, or if the motor is operated using the factory settings, resulting in the motor stalling, lower the set value of L3-02.
- If using the motor in the constant output range, L3-02 will be automatically lowered to prevent stalling. L3-03 is the limit value to prevent the stall prevention level in the constant output range from being reduced more than necessary.
- Set the constants as a percent taking the inverter rated voltage to be 100%.

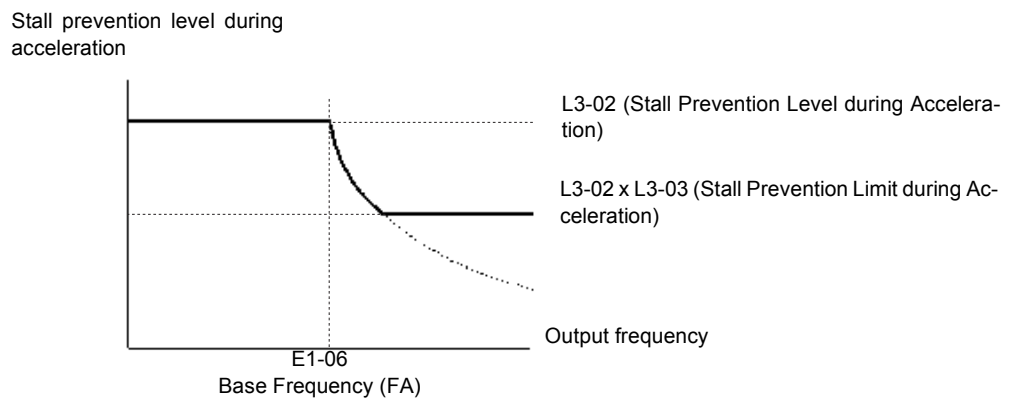

Fig 6.22 Stall Prevention Level and Limit During Acceleration

◆ Preventing Overvoltage During Deceleration (Stall Prevention During Deceleration Function)

The Stall Prevention During Deceleration function makes the rate of deceleration more gentle to suppress increases in DC bus voltage when the DC bus voltage exceeds the set value during motor deceleration.

This function automatically lengthens the deceleration time with respect to the bus voltage, even if the deceleration time has been set to a considerably small value.

If L3-04 is set to 1 or 2, when the main circuit DC voltage approaches the stall prevention level during deceleration, deceleration stops, and when deceleration falls below the level, is restarted. Using this operation, deceleration time is automatically lengthened. If L3-04 is set to 1, deceleration time returns to the set value, and if L3-04 is set to 2, deceleration is automatically adjusted to a faster deceleration time within the range of the stall prevention level during deceleration.

■ Related Constants

Con- stant Number	Name	Description	Setting Range	Factory Setting	Change during Opera- tion	Control Methods				
	Display					V/f	V/f with PG	Open Loop Vector 1	Flux Vec- tor	Open Loop Vector 2
L3-04	Stall preven- tion selection during decel	0: Disabled (Deceleration as set. If deceleration time is too short, a main circuit overvoltage may result.)	0 to 3*	1	No	Q	Q	Q	Q	Q
	StallP Decel Sel	1: Enabled (Deceleration is stopped when the main circuit voltage exceeds the overvoltage level. Deceleration restarts when voltage is returned.) 2: Intelligent deceleration mode (Deceleration rate is automatically adjusted so that in Inverter can decelerate in the shortest possible time. Set deceleration time is disregarded.) 3: Enabled (with Braking Resistor Unit) When a braking option (Braking Resistor, Braking Resistor Unit, Braking Unit) is used, always set to 0 or 3.								

* The setting range is 0 to 2 for flux vector control and open-loop vector control 2.

■Setting Example

An example of stall prevention during deceleration when L3-04 is set to 1 as shown below.

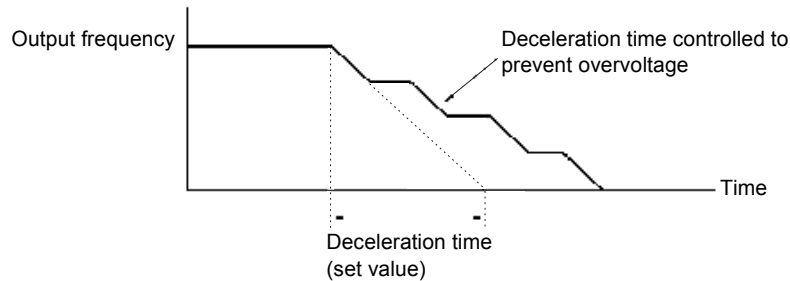

Fig 6.23 Stall Prevention During Deceleration Operation

■Setting Precautions

- The stall prevention level during deceleration differs depending on the Inverter capacity. Refer to the following table for details.

Inverter Capacity		Stall Prevention Level during Deceleration (V)
200 V class		380
400 V class	E1-01 \geq 400 V	760
	E1-01 $<$ 400 V	660

- When using the braking option (braking resistor, Braking Resistor Units, and Braking Units), be sure to set constant L3-04 to 0 or 3.
- To decelerate at a shorter time than the deceleration time set when L3-04 is set to 0 with the braking option enabled, set L3-04 to 3.
- The setting of L3-04 is ignored for flux vector control or open-loop vector control 2.

Adjusting Frequency References

This section explains methods of adjusting frequency references.

◆ Adjusting Analog Frequency References

Gain and bias are among the constants used to adjust analog inputs.

■ Related Constants

Constant Number	Name	Description	Setting Range	Factory Setting	Change during Operation	Control Methods				
	Display					V/f	V/f with PG	Open Loop Vector 1	Flux Vector	Open Loop Vector 2
H3-01	Signal level selection (terminal A1)	0: 0 to ±10V [11-bit + polarity (positive/negative) input]	0 or 1	0	No	A	A	A	A	A
	Term A1 Signal	1: 0 to ±10V								
H3-02	Gain (terminal A1)	Sets the frequency when 10 V is input, as a percentage of the maximum output frequency.	0.0 to 1000.0	100.0%	Yes	A	A	A	A	A
	Terminal A1 Gain									
H3-03	Bias (terminal A1)	Sets the frequency when 0 V is input, as a percentage of the maximum frequency.	-100.0 to +100.0	0.0%	Yes	A	A	A	A	A
	Terminal A1 Bias									
H3-04	Signal level selection (terminal A3)	0: 0 to ±10V [11-bit + polarity (positive/negative) input]	0 or 1	0	No	A	A	A	A	A
	Term A3 Signal	1: 0 to ±10V								
H3-05	Multi-function analog input (terminal A3)	Sets the function.	0 to 1F	2	No	A	A	A	A	A
	Terminal A3 Sel									
H3-06	Gain (terminal A3)	Sets the input gain (level) when terminal 16 is 10V.	0.0 to 1000.0	100.0%	Yes	A	A	A	A	A
	Terminal A3 Gain	Set according to the 100% value selected from H3-05.								
H3-07	Bias (terminal A3)	Sets the input gain (level) when terminal 16 is 10V.	-100.0 to +100.0	0.0%	Yes	A	A	A	A	A
	Terminal A3 Bias	Set according to the 100% value selected from H3-05.								
H3-08	Multi-function analog input terminal A2 signal level selection	0: Limit negative frequency settings for gain and bias settings to 0. 1: Do not limit negative frequency settings for gain and bias settings to 0 (i.e., allow reverse operation). 2: 4 to 20 mA (9-bit input).	0 to 2	2	No	A	A	A	A	A
	Term A2 Signal	Switch current and voltage input using the switch on the control panel.								

Constant Number	Name	Description	Setting Range	Factory Setting	Change during Operation	Control Methods				
	Display					V/f	V/f with PG	Open Loop Vector 1	Flux Vector	Open Loop Vector 2
H3-09	Multi-function analog input terminal A2 function selection	Select multi-function analog input function for terminal A2.	0 to 1F	0	No	A	A	A	A	A
	Terminal A2 Sel									
H3-10	Gain (terminal A2)	Sets the input gain (level) when terminal 14 is 10 V (20 mA). Set according to the 100% value for the function set for H3-09.	0.0 to 1000.0	100.0%	Yes	A	A	A	A	A
	Terminal A2 Gain									
H3-11	Bias (terminal A2)	Sets the input gain (level) when terminal 14 is 0 V (4 mA). Set according to the 100% value for the function set for H3-09.	-100.0 to +100.0	0.0%	Yes	A	A	A	A	A
	Terminal A2 Bias									
H3-12	Analog input filter time constant	Sets primary delay filter time constant in seconds for the two analog input terminal (A1 and A2). Effective for noise control etc.	0.00 to 2.00	0.03 s	No	A	A	A	A	A
	Filter Avg Time									

■ Adjusting Analog Frequency Reference Using Constants

The frequency reference is input from the control circuit terminals using analog voltage and current.

If using frequency reference terminal A1 as an input terminal, perform adjustments using constants H3-02 and H3-03. If using multi-function analog input terminal A2 as a frequency reference terminal, perform adjustments using H3-10 and H3-11.

Adjustment can be made using H3-06 and H3-07 when multi-function analog input terminal A3 is used as a frequency reference terminal.

Frequency reference

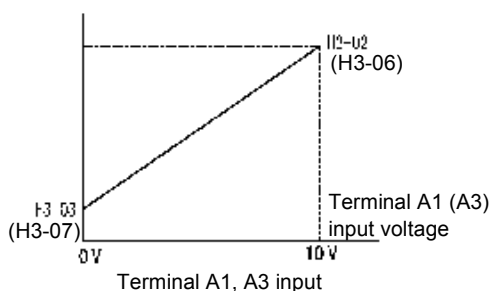

Frequency reference

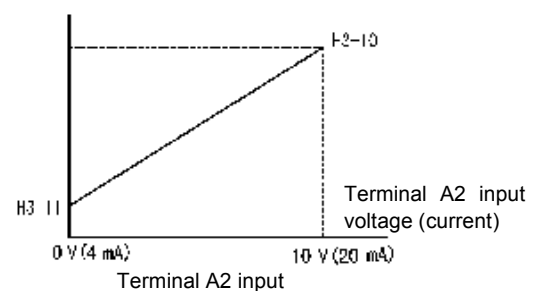

Fig 6.24 Terminals A1 and A2 Inputs

■ Adjusting Frequency Gain Using an Analog Input

When H3-09 or H3-05 is set to 1 (frequency gain), you can adjust the frequency gain using the analog input terminal A2 or A3.

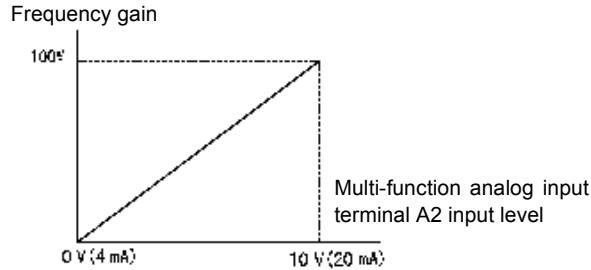
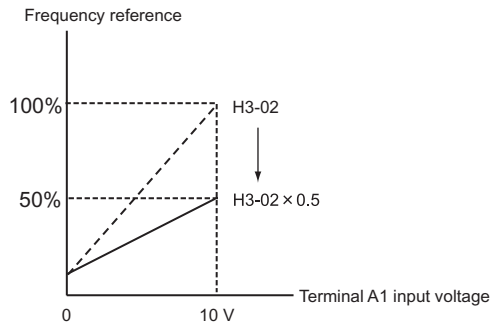

Fig 6.25 Frequency Gain Adjustment (Terminal A2 Input)

The frequency gain for terminal A1 is the sum of H3-02 and terminal A2 gain. For example, when H3-02 is set to 100% and terminal A2 is set to 5 V, the terminal A1 frequency reference will be 50%.



Setting Precautions

H3-05 cannot be set to 0.

■ Adjusting Frequency Bias Using an Analog Input

When constant H3-09 or H3-05 is set to 0 (add to terminal A1), the frequency equivalent to the terminal A2 or A3 input voltage is added to A1 as a bias.

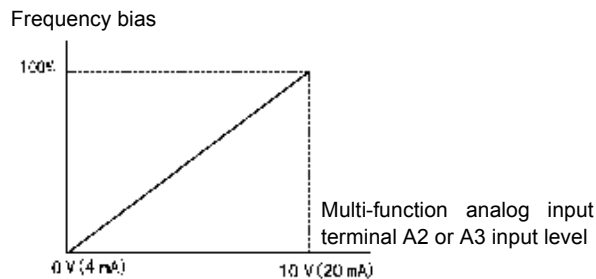
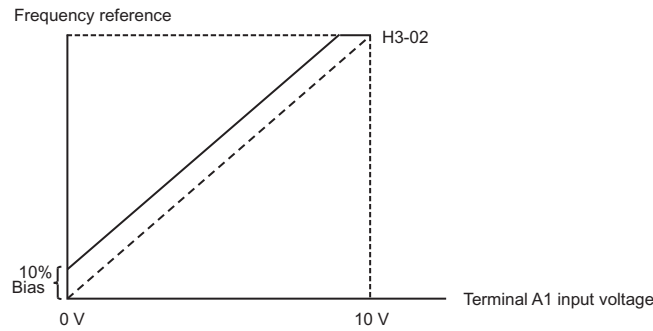

Fig 6.26 Frequency Bias Adjustment (Terminal A2 or A3 Input)

For example, if H3-02 is 100%, H3-03 is 0%, and terminal A2 is set to 1 V, the frequency reference from terminal A1 when 0 V is input to A1 will be 10%.



◆ Operation Avoiding Resonance (Jump Frequency Function)

The jump frequency function operates the motor while avoiding resonance caused by characteristic frequencies in the machinery.

This function is effective in creating a frequency reference dead band.

During constant-speed operation, operation within the jump frequency range is prohibited. Smooth operation still used during acceleration and deceleration, i.e., jumps are not performed.

■ Related Constants

Constant Number	Name	Description	Setting Range	Factory Setting	Change during Operation	Control Methods				
	Display					V/f	V/f with PG	Open Loop Vector 1	Flux Vector	Open Loop Vector 2
d3-01	Jump frequency 1	Set the center values of the jump frequencies in Hz. This function is disabled by setting the jump frequency to 0 Hz. Always ensure that the following applies: $d3-01 \geq d3-02 \geq d3-03$ Operation in the jump frequency range is prohibited but during acceleration and deceleration, speed changes smoothly without jump.	0.0 to 400.0	0.0 Hz	No	A	A	A	A	A
	Jump Freq 1									
d3-02	Jump frequency 2									
	Jump Freq 2									
d3-03	Jump frequency 3									
	Jump Freq 3									
d3-04	Jump frequency width	Sets the jump frequency bandwidth in Hz. The jump frequency will be the jump frequency \pm d3-04.	0.0 to 20.0	1.0 Hz	No	A	A	A	A	A
	Jump Bandwidth									

The relationship between the output frequency and the jump frequency reference is as follows:

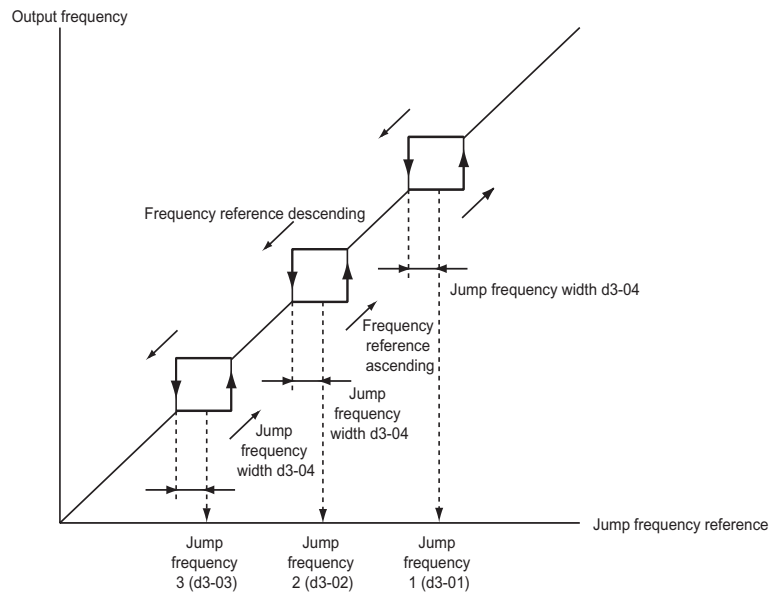

Fig 6.27 Jump Frequency

■ Setting Jump Frequency Reference Using an Analog Input

When constant H3-09 (Multi-function Analog Input Terminal A2 Function Selection) or H3-05 (Multi-function Analog Input Terminal A3 Function Selection) is set to A (jump frequency), you can change the jump frequency using the terminal A2 input level.

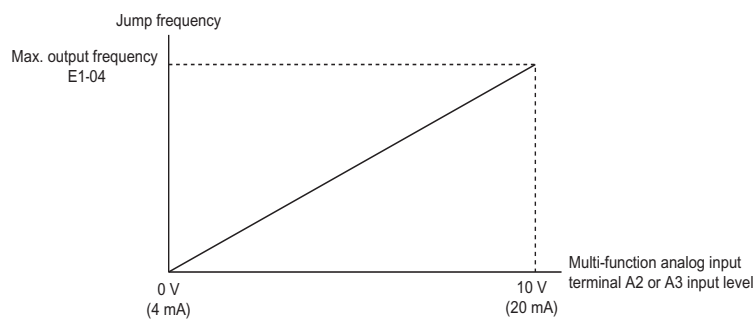

Fig 6.28 Jump Frequency Setting Using an Analog Input

■ Setting Precautions

- Set the jump frequency according to the following formula: $d3-01 \geq d3-02 \geq d3-03 > \text{Analog input}$.
- When constants d3-01 to d3-03 are set to 0 Hz, the jump frequency function is disabled.

◆ Adjusting Frequency Reference Using Pulse Train Inputs

The frequency reference can be adjusted when b1-01 (Reference Selection) is set to 4 (Pulse Train Input). Set the pulse frequency in constant H6-02 to 100% reference, and then adjust the gain and bias accordingly using H6-03 and H6-04.

■ Related Constants

Constant Number	Name	Description	Setting Range	Factory Setting	Change during Operation	Control Methods				
	Display					V/f	V/f with PG	Open Loop Vector 1	Flux Vector	Open Loop Vector 2
H6-01	Pulse train input function selection	0: Frequency reference 1: PID feedback value 2: PID target value	0 to 2	0	No	A	A	A	A	A
	Pulse Input Sel									
H6-02	Pulse train input scaling	Set the number of pulses in hertz, taking the reference to be 100%.	1000 to 32000	1440 Hz	Yes	A	A	A	A	A
	PI Scaling									
H6-03	Pulse train input gain	Set the input gain level as a percent when the pulse train set in H6-02 is input.	0.0 to 1000.0	100.0%	Yes	A	A	A	A	A
	Pulse Input Gain									
H6-04	Pulse train input bias	Set the input bias when the pulse train is 0.	-100.0 to 100.0	0.0%	Yes	A	A	A	A	A
	Pulse Input Bias									
H6-05	Pulse train input filter time	Set the pulse train input primary delay filter time constant in seconds.	0.00 to 2.00	0.10 s	Yes	A	A	A	A	A
	PI Filter Time									

The following diagram shows the method for adjusting the frequency reference using pulse inputs.

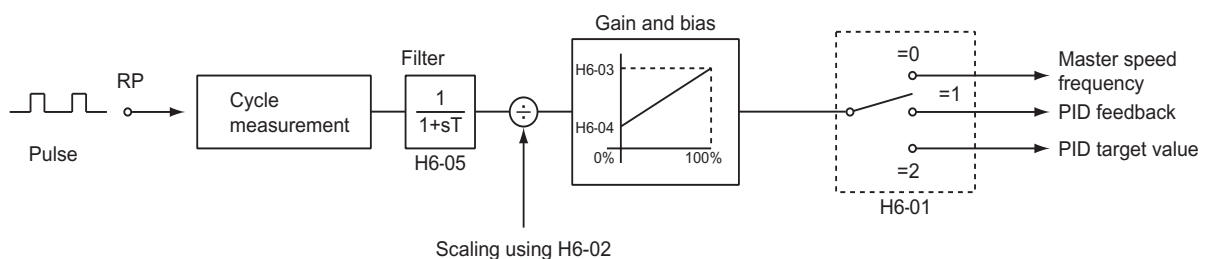

Fig 6.29 Frequency Reference Adjustments Using Pulse Train Inputs

Speed Limit (Frequency Reference Limit Function)

This section explains how to limit the motor speed.

◆ Limiting Maximum Output Frequency

If you do not want the motor to rotate above a given frequency, use constant d2-01.

Set the upper limit value of the Inverter output frequency as a percent, taking E1-04 (Maximum Output Frequency) to be 100%.

■ Related Constants

Constant Number	Name	Description	Setting Range	Factory Setting	Change during Operation	Control Methods				
	Display					V/f	V/f with PG	Open Loop Vector 1	Flux Vector	Open Loop Vector 2
d2-01	Frequency reference upper limit	Set the output frequency upper limit as a percent, taking the max. output frequency to be 100%.	0.0 to 110.0	100.0%	No	A	A	A	A	A
	Ref Upper Limit									

◆ Limiting Minimum Frequency

If you do not want the motor to rotate at below a given frequency, use constants d2-02 or d2-03.

There are two methods of limiting the minimum frequency, as follows:

- Adjust the minimum level for all frequencies.
- Adjust the minimum level for the master speed frequency (i.e., the lower levels of the jog frequency, multi-step speed frequency, and auxiliary frequency will not be adjusted).

■ Related Constants

Constant Number	Name	Description	Setting Range	Factory Setting	Change during Operation	Control Methods				
	Display					V/f	V/f with PG	Open Loop Vector 1	Flux Vector	Open Loop Vector 2
d2-02	Frequency reference lower limit	Sets the output frequency lower limit as a percentage of the maximum output frequency.	0.0 to 110.0	0.0%	No	A	A	A	A	A
	Ref Lower Limit									
d2-03	Master speed reference lower limit	Set the master speed reference lower limit as a percent, taking the max. output frequency to be 100%.	0.0 to 110.0	0.0%	No	A	A	A	A	A
	Ref1 Lower Limit									

■ Adjusting Frequency Lower Limit Using an Analog Input

If you set constant H3-09 (Multi-function Analog Input Terminal A2 Function Selection) or H3-05 (Multi-function Analog Input Terminal A3 Function Selection) to 9 (output frequency lower level), you can adjust the frequency lower level using the terminal A2 input level.

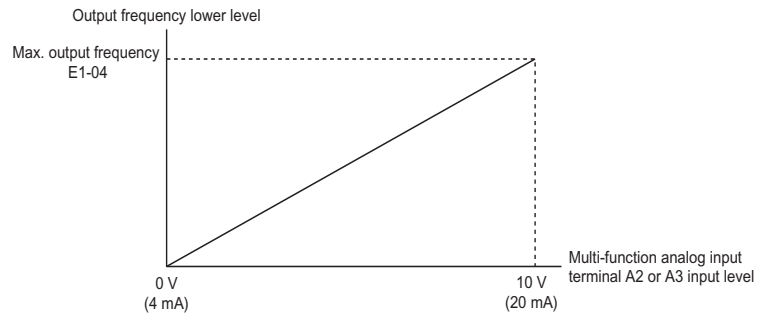

Fig 6.30 Output Frequency Lower Level for Multi-function Analog Input



INFO

If constant d2-02 and terminal A2 output frequency lower level have been set at the same time, the larger set value will become the frequency lower limit.

Improved Operating Efficiency

This section explains functions for improving motor operating efficiency.

◆ Reducing Motor Speed Fluctuation (Slip Compensation Function)

When the load is large, the amount of motor slip also grows large and the motor speed decreases. The slip compensation function controls the motor at a constant speed, regardless of changes in load. When the motor is operating at the rated load, constant E2-02 (Motor Rated Slip) × the frequency in constant C3-01 is added to the output frequency.

■ Related Constants

Constant Number	Name	Description	Setting Range	Factory Setting	Change during Operation	Control Methods				
	Display					V/f	V/f with PG	Open Loop Vector 1	Flux Vector	Open Loop Vector 2
C3-01	Slip compensation gain	Used to improve speed accuracy when operating with a load. Usually setting is not necessary. Adjust this constant at the following times. <ul style="list-style-type: none"> When actual speed is low, increase the set value. When actual speed is high, decrease the set value. 	0.0 to 2.5	1.0*	Yes	A	No	A	A	A
	Slip Comp Gain									
C3-02	Slip compensation primary delay time	Slip compensation primary delay time is set in ms units. Usually setting is not necessary. Adjust this constant at the following times. <ul style="list-style-type: none"> Reduce the setting when slip compensation responsive is slow. When speed is not stabilized, increase the setting. 	0 to 10000	200 ms*	No	A	No	A	No	No
	Slip Comp Time									
C3-03	Slip compensation limit	Sets the slip compensation limit as a percentage of motor rated slip.	0 to 250	200%	No	A	No	A	No	No
	Slip Comp Limit									
C3-04	Slip compensation selection during regeneration	0: Disabled. 1: Enabled. When the slip compensation during regeneration function has been activated, as regeneration capacity increases momentarily, it may be necessary to use a braking option (braking resistor, Braking Resistor Unit or Braking Unit.)	0 or 1	0	No	A	No	A	No	No
	Slip Comp Regen									
C3-05	Output voltage limit operation selection	0: Disabled. 1: Enabled. (The motor flux will be lowered automatically when the output voltage become saturated.)	0 or 1	0	No	No	No	A	A	A
	Output V limit									

* The factory setting will change when the control method is changed. (Open-loop vector 1 factory settings are given.)

■ Adjusting Slip Compensation Gain

You can switch the C3-01 constant settings as shown below by changing the control method.

- V/f control without PG: 0.0
- Open-loop vector control: 1.0
- Flux vector control: 1.0

Set C3-01 to 1.0 to compensate the rated slip set using the rated torque output status.

Adjust the slip compensation gain using the following procedure.

1. Set E2-02 (Motor Rated Slip) and E2-03 (Motor No-load Current) correctly.

You can calculate the motor rated slip from the values on the motor nameplate using the following formula.

Amount of motor rated slip (Hz) = Motor rated frequency (Hz) - No. of rated rotations (min^{-1}) \times No. of motor poles / 120

Set the values for rated voltage, rated frequency, and no-load current in the motor unladen current. The motor rated slip is set automatically in the vector control using autotuning.

2. In V/f control, set C3-01 to 1.0. Setting this constant to 0.0 disables slip compensation.
3. Apply a load, and measure the speed to adjust the slip compensation gain. Adjust the slip compensation gain by 0.1 at a time. If the speed is less than the target value, increase the slip compensation gain, and if the speed is greater than the target value, reduce the slip compensation gain.

For flux vector control, the slip compensation gain is used as the motor temperature compensation gain. When the motor temperature increases, the motor's internal constant increases, resulting in an increase in slip. If C3-01 is set, the amount of slip is adjusted as the temperature rises. Set C3-01 if the amount of torque varies with the temperature when using torque control or a torque limit. The larger the value of C3-01, the larger the compensation.

■ Adjusting Slip Compensation Primary Delay Time Constant

Set the slip compensation primary delay time constant in ms.

You can switch the factory settings as follows by changing the control method.

- V/f control without PG: 2000 ms
- Open-loop vector control: 200 ms

Normally, there is no need to make these settings. When the slip compensation response is low, lower the set value. When the speed is unstable, increase the set value.

■ Adjusting Slip Compensation Limit

Set the upper limit for the slip compensation amount as a percent, taking the motor rated slip amount as 100%.

If the speed is lower than the target value but does not change even when you adjust the slip compensation gain, the motor may have reached the slip compensation limit. Increase the limit, and check the speed again. Make the settings, however, to make sure that the value of the slip compensation limit and reference frequency does not exceed the tolerance of the machine.

The following diagram shows the slip compensation limit for the constant torque range and fixed output range.

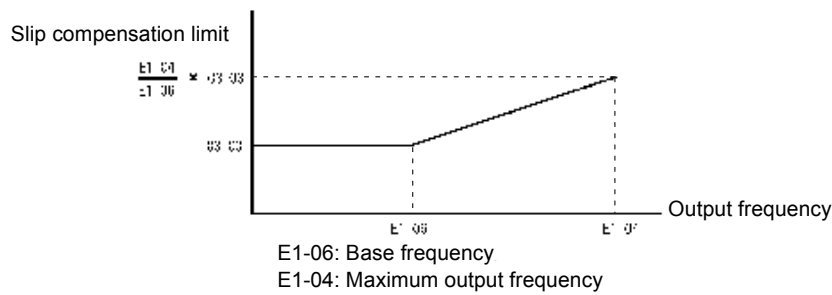

Fig 6.31 Slip Compensation Limit

■ Selecting Slip Compensation Function During Regeneration

Set whether to enable or disable the slip compensation function during regeneration.

If the slip compensation function operates during regeneration, you might have to use the braking option (braking resistor, Braking Resistor Unit, and Braking Unit) to momentarily increase the regenerative amount.

■ Selecting Output Voltage Limit Operation

If output voltage saturation occurs while the output voltage limit operation is disabled, the output current will not change, but torque control accuracy will be lost. If torque control accuracy is required, change the settings to enable the output voltage limit operation.

If the output voltage limit operation is enabled, motor magnetic flux current is controlled automatically, and torque control accuracy is maintained to limit the output voltage references. Consequently, the output current will increase by approximately 10% maximum (with rated load) compared with when the output voltage limit operation is disabled, so check the Inverter current margin.

Setting Precautions

- If using the device at medium to low speed only, if the power supply voltage is 10% or more higher than the motor rated voltage, or if the torque control accuracy at high speeds is insufficient, it is not necessary to change the output voltage limit operation.
- If the power supply voltage is too low compared with the motor rated voltage, torque control accuracy may be lost even if the output voltage limit operation is enabled.

◆ Compensating for Insufficient Torque at Startup and Low-speed Operation (Torque Compensation)

The torque compensation function detects that the motor load has increased, and increases the output torque.

V/f control calculates and adjusts the motor primary loss voltage according to the output voltage (V), and compensates for insufficient torque at startup and during low-speed operation. Calculate the compensation voltage as follows: Motor primary voltage loss \times constant C4-01.

Vector control separates the motor excitation current and the torque current by calculating the motor primary current, and controlling each of the two separately.

Calculate the torque current as follows: Calculated torque reference \times C4-01

■ Related Constants

Constant Number	Name	Description	Setting Range	Factory Setting	Change during Operation	Control Methods				
	Display					V/f	V/f with PG	Open Loop Vector 1	Flux Vector	Open Loop Vector 2
C4-01	Torque compensation gain	Sets torque compensation gain as a ratio. Usually setting is not necessary. Adjust in the following circumstances: <ul style="list-style-type: none"> When the cable is long; increase the set value. When the motor capacity is smaller than the Inverter capacity (Max. applicable motor capacity), increase the set values. When the motor is oscillating, decrease the set values. Adjust the output current range at minimum speed rotation so that it does not exceed the Inverter rated output current. Do not alter the torque compensation gain from its default (1.00) when using the open-loop vector control method.	0.00 to 2.50	1.00	Yes	A	A	A	No	No
	Torq Comp Gain									
C4-02	Torque compensation primary delay time constant	The torque compensation delay time is set in ms units. Usually setting is not necessary. Adjust in the following circumstances: <ul style="list-style-type: none"> When the motor is oscillating, increase the set values. When the responsiveness of the motor is low, decrease the set values. 	0 to 10000	20 ms *	No	A	A	A	No	No
	Torq Comp Time									

* The factory setting will change when the control method is changed. (Open-loop vector 1 factory settings are given.)

■ Adjusting Torque Compensation Gain

Normally, there is no need to make this adjustment. Do not adjust the torque compensation gain when using open-loop vector control.

Adjust the torque compensation gain using V/f control in the following circumstances.

- If the cable is very long, increase the set value.
- If the (maximum applicable) motor capacity is smaller than the Inverter capacity, increase the set value.
- If the motor is vibrating, reduce the set value.

Adjust this constant so that the output current during low-speed rotation does not exceed the Inverter rated output current range.

■ Adjusting the Torque Compensation Primary Delay Time Constant

Set the torque compensation function primary delay in ms.

You can switch the factory settings as follows by changing the control method settings:

- V/f control without PG: 200 ms
- V/f control with PG: 200 ms
- Open-loop vector control: 20 ms

Normally, there is no need to make this setting. Adjust the constant as shown below.

- If the motor is vibrating, increase the set value.
- If the motor response is low, decrease the set value.

◆ Hunting-prevention Function

The hunting-prevention function suppresses hunting when the motor is operating with a light load. This function can be used in V/f without PG and V/f with PG.

■ Related Constants

Constant Number	Name	Description	Setting Range	Factory Setting	Change during Operation	Control Methods				
	Display					V/f	V/f with PG	Open Loop Vector 1	Flux Vector	Open Loop Vector 2
N1-01	Hunting-prevention function selection	0: Hunting-prevention function disabled 1: Hunting-prevention function enabled	0 or 1	1	No	A	A	No	No	No
	Hunt Prev Select	The hunting-prevention function suppresses hunting when the motor is operating with a light load. This function is enabled in V/f control method only. If high response is to be given priority over vibration suppression, disable the hunting-prevention function.								
N1-02	Hunting-prevention gain	Set the hunting-prevention gain multiplication factor. Normally, there is no need to make this setting. Make the adjustments as follows:	0.00 to 2.50	1.00	No	A	A	No	No	No
	Hunt Prev Gain	<ul style="list-style-type: none"> • If vibration occurs with light load, increase the setting. • If the motor stalls, reduce the setting. If the setting is too large, the voltage will be too suppressed and the motor may stall.								

◆ Stabilizing Speed (Speed Feedback Detection Function)

The speed feedback detection control (AFR) function measures the stability of the speed when a load is suddenly applied, by calculating the amount of fluctuation of the torque current feedback value, and compensating the output frequency with the amount of fluctuation.

■ Related Constants

Constant Number	Name	Description	Setting Range	Factory Setting	Change during Operation	Control Methods				
	Display					V/f	V/f with PG	Open Loop Vector 1	Flux Vector	Open Loop Vector 2
N2-01	Speed feedback detection control (AFR) gain	Set the internal speed feedback detection control gain using the multiplication function. Normally, there is no need to make this setting. Adjust this constant as follows: • If hunting occurs, increase the set value. • If response is low, decrease the set value. Adjust the setting by 0.05 at a time, while checking the response.	0.00 to 10.00	1.00	No	No	No	A	No	No
	AFR Gain									
N2-02	Speed feedback detection control (AFR) time constant	Set the time constant to decide the rate of change in the speed feedback detection control.	0 to 2000	50 ms	No	No	No	A	No	No
	AFR Time									

Machine Protection

This section explains functions for protecting the machine.

◆ Reducing Noise and Leakage Current

The switching frequency of the Inverter's output transistor can be changed to reduce carrier noise and leakage current from the motor.

■ Related Constants

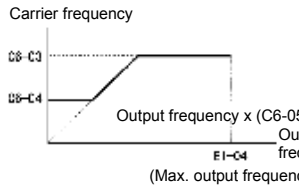
Constant Number	Name	Description	Setting Range	Factory Setting	Change during Operation	Control Methods				
	Display					V/f	V/f with PG	Open Loop Vector 1	Flux Vector	Open Loop Vector 2
C6-02	Carrier frequency selection	Select carrier wave fixed pattern. Select F to enable detailed settings using constants C6-03 to C6-05.	1 to F	6 *2	No	Q	Q	Q	A	No *5
	CarrierFreq Sel									
C6-03	Carrier frequency upper limit	Set the carrier frequency upper limit and lower limit in kHz units. The carrier frequency gain is set as follows: With the vector control method, the upper limit of the carrier frequency is fixed in C6-03.	2.0 to 15.0 *3 *4	15.0 kHz *2	No	A	A	A	A	No
	CarrierFreq Max									
C6-04	Carrier frequency lower limit		0.4 to 15.0 *3 *4	15.0 kHz *2	No	A	A	No	No	No
	CarrierFreq Min									
C6-05	Carrier frequency proportional gain	K is a coefficient that depends on the setting of C6-03. C6-03 ≥ 10.0 kHz: K = 3 10.0 kHz > C6-03 ≥ 5.0 kHz: K = 2 5.0 kHz > C6-03: K = 1	00 to 99 *4	00	No	A	A	No	No	No
	CarrierFreq Gain									
C6-11	Carrier frequency selection for open-loop vector control 2	Select the carrier frequency when open-loop vector control 2 is used. 1: 2 kHz 2: 4 kHz 3: 6 kHz 4: 8 kHz	1 to 4	4	No	No *5	No *5	No *5	No *5	Q
	Carrier Freq Sel									

- * 1. The setting range depends on the control method of the Inverter.
- * 2. The factory setting depends on the capacity of the Inverter.
- * 3. The setting range depends on the capacity of the Inverter.
- * 4. This constant can be monitored or set only when 1 is set for C6-01 and F is set for C6-02.
- * 5. Displayed in Quick Programming Mode when motor 2 is set for a multi-function input.

■ Control Mode and Carrier Frequency Settings

Carrier frequency settings are restricted as listed in the following table according to the control mode selection.

Control Mode	Carrier Frequency
V/f control with or without a PG	1: 2.0 kHz 2: 5.0 kHz 3: 8.0 kHz 4: 10.0 kHz 5: 12.5 kHz 6: 15.0 kHz F: Any setting* Detailed settings are available in C6-03, C6-04, and C6-05.
Open-loop vector control 1 or Flux vector control	1: 2.0 kHz 2: 5.0 kHz 3: 8.0 kHz 4: 10.0 kHz 5: 12.5 kHz 6: 15.0 kHz F: Any setting* The upper limit of the carrier frequency is determined by C6-03.
Open-loop vector control 2	1: 2.0 kHz 2: 4.0 kHz 3: 6.0 kHz 4: 8.0 kHz

* The upper limit of the carrier frequency depends on the Inverter capacity.

■ Carrier Frequency Setting Precautions

When selecting the carrier frequency, observe the following precautions.

- Adjust the carrier frequency according to the cases shown below.
If the wiring distance between Inverter and motor is long: Set the carrier frequency low. (Use the following values as guidelines.)

Wiring Length	50 m or less	100 m or less	Over 100 m
C6-02 (carrier frequency selection) setting	1 to 6 (15 kHz)	1 to 4 (10 kHz)	1 to 2 (5 kHz)

If speed and torque are inconsistent at low speeds: Set the carrier frequency low.

If leakage current from the Inverter is large: Set the carrier frequency low.

If metallic noise from the motor is large: Set the carrier frequency high.

- When using V/f control or V/f control with PG, you can vary the carrier frequency according to the output frequency, as shown in the following diagram, by setting C6-03 (Carrier Frequency Upper Limit), C6-04 (Carrier Frequency Lower Limit), and C6-05 (Carrier Frequency Proportional Gain).

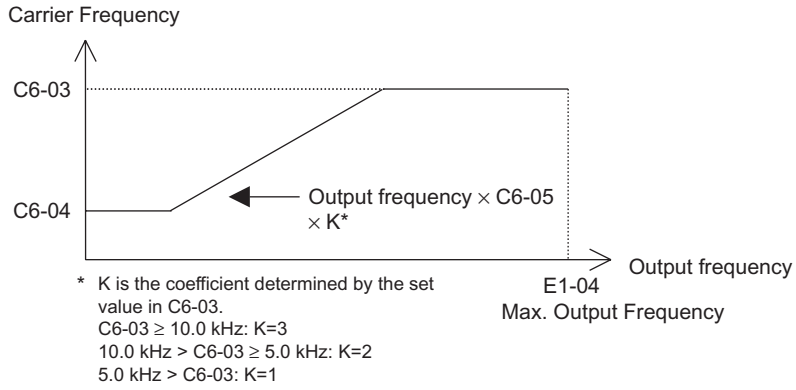

Fig 6.32

- With vector control, the carrier frequency is fixed to the Carrier Frequency Upper Limit in C6-03 if user-set or by the carrier frequency set in C6-02.
- To fix the carrier frequency, set C6-03 and C6-04 to the same value, or set C6-05 to 0.
- If the settings are as shown below, OPE11 (Constant setting error) will occur. If Carrier Frequency Proportional Gain (C6-05) > 6 and C6-03 < C6-04.
- Depending on the carrier frequency setting, the Inverter's overload level may be reduced. Even when the overload current falls to below 150%, OL2 (Inverter overload) will be detected. The Inverter overload current reduction level is shown below.

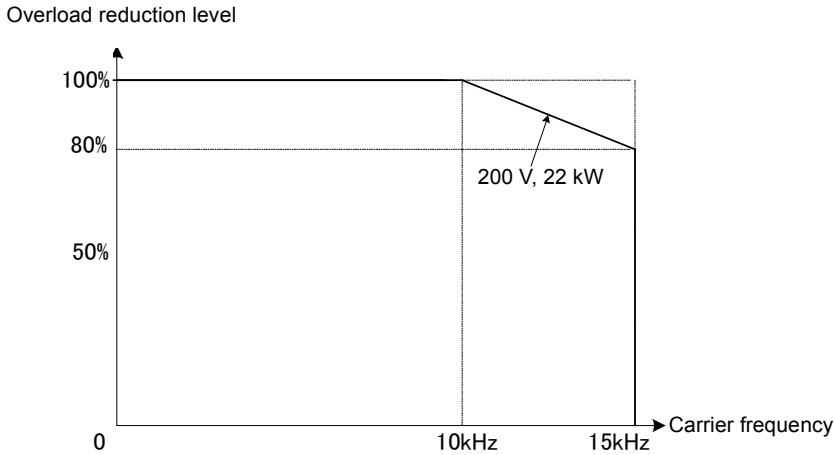

Fig 6.33 Overload Reduction Level for V/f Control, V/f Control with PG, Open-loop Vector Control 1, and Flux Vector Control

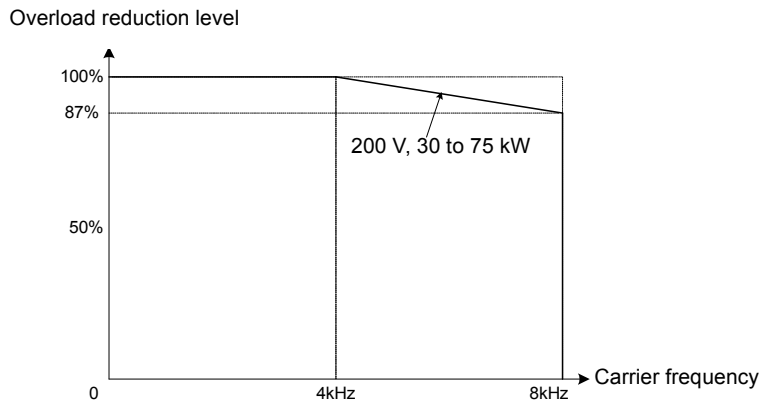

Fig 6.34 Overload Reduction Level for Open-loop Vector Control 2

◆ Limiting Motor Torque (Torque Limit Function)

The motor torque limit function is enabled only with open-loop torque control.

In the open-loop vector control method, the user-set value is applied to the torque limit by calculating internally the torque output by the motor. Enable this function if you do not want a torque above a specified amount to be applied to the load, or if you do not want a regeneration value above a specified amount to occur.

■ Related Constants

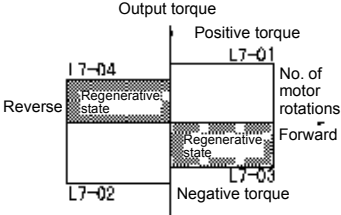
Constant Number	Name	Description	Setting Range	Factory Setting	Change during Operation	Control Methods				
						V/f	V/f with PG	Open Loop Vector 1	Flux Vector	Open Loop Vector 2
L7-01	Forward drive torque limit	Sets the torque limit value as a percentage of the motor rated torque. Four individual regions can be set. 	0 to 300	200%	No	No	No	A	A	A
	Torq Limit Fwd									
L7-02	Reverse drive torque limit		0 to 300	200%	No	No	No	A	A	A
	Torq Limit Rev									
L7-03	Forward regenerative torque limit		0 to 300	200%	No	No	No	A	A	A
	Torq Lmt Fwd Rgn									
L7-04	Reverse regenerative torque limit		0 to 300	200%	No	No	No	A	A	A
	Torq Lmt Rev Rgn									

Multi-function Analog Input (H3-05, H3-09)

Setting Value	Function	Contents (100%)	Control Methods				
			V/f	V/f with PG	Open Loop Vector 1	Flux Vector	Open Loop Vector 2
10	Positive torque limit	Motor's rated torque	No	No	Yes	Yes	Yes
11	Negative torque limit	Motor's rated torque	No	No	Yes	Yes	Yes
12	Regenerative torque limit	Motor's rated torque	No	No	Yes	Yes	Yes
15	Positive/negative torque limit	Motor's rated torque	No	No	Yes	Yes	Yes

Note The forward torque limit is the limit value when the analog input signal generates forward torque. This torque limit setting is enabled even when the analog input signal generates forward torque while the motor is operating (regeneration).

■ Setting the Torque Limit in Constants

Using L7-01 to L7-04, you can set individually four torque limits in the following directions: Forward drive, reverse drive, forward regeneration, and reverse regeneration.

■ Set the Torque Limit Value Using an Analog Input

You can change the analog input level torque limit value by setting the torque limit in multi-function analog input terminals A2 and A3.

The analog input terminal signal level is factory-set as follows:

Multi-function analog input terminal A2: 4 to 20 mA

Multi-function analog input terminal A3: 0 to 10

The following diagram shows the relationship between the torque limits.

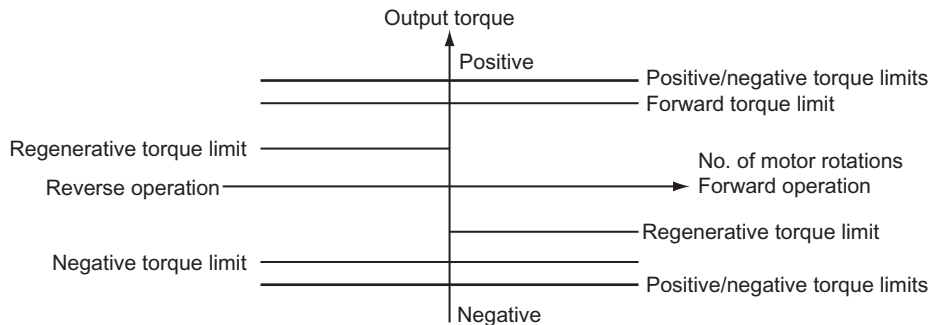

Fig 6.35 Torque Limit by Analog Input

■ Setting Torque Limits Using Constants and an Analog Input

The following block diagram shows the relationship between torque limit using constants and torque limit using an analog input.

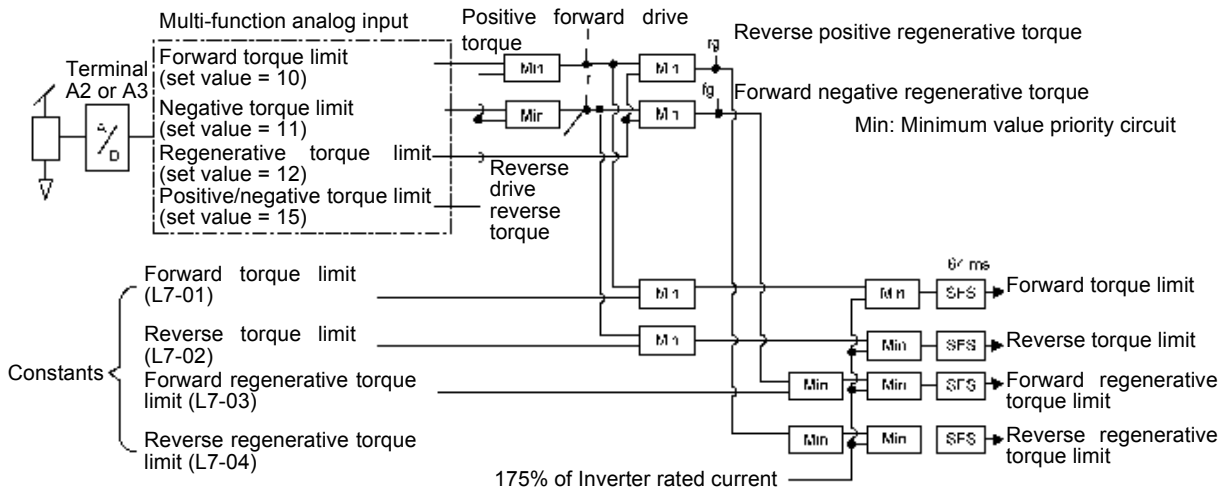

Fig 6.36 Torque Limit Using Constants and an Analog Input

■ Setting Precautions

- When the torque limit function is operating, control and compensation of the motor speed is disabled because torque control is given priority.
- When using the torque limit to raise and lower loads, do not carelessly lower the torque limit value, as this may result in the motor falling or slipping.
- Torque limits using an analog input are the upper limit value (during 10 V or 20 mA input) of 100% of the motor rated torque. To make the torque limit value during 10 V or 20 mA input 150% of the rated torque, set the input terminal gain to 150.0 (%). Adjust the gain for multi-function analog input terminal A2 using H3-10 and for multi-function analog input terminal A3 using H3-06.
- The torque limit accuracy is $\pm 5\%$ at the output frequency of 10 Hz or above. When output frequency is less than 10 Hz, accuracy is lowered.

◆ Preventing Motor Stalling During Operation

Stall prevention during operation prevents the motor from stalling by automatically lowering the Inverter's output frequency when a transient overload occurs while the motor is operating at a constant speed.

Stall prevention during operation is enabled only during V/f control. If the Inverter output current continues to exceed the setting in constant L3-06 for 100 ms or longer, the motor speed is reduced. Set whether to enable or disable deceleration time using constant L3-05. Set the deceleration time using C1-02 (Acceleration time 1) or C1-04 (Acceleration Time 2).

If the Inverter output current reaches the set value in L3-06 - 2% (Inverter Rated Output Current), the motor will accelerate again at the frequency set or the acceleration time set.

■ Related Constants

Con- stant Number	Name	Description	Setting Range	Factory Setting	Change during Opera- tion	Control Methods				
	Display					V/f	V/f with PG	Open Loop Vector 1	Flux Vec- tor	Open Loop Vector 2
L3-05	Stall preven- tion selection during run- ning	0: Disabled (Runs as set. With a heavy load, the motor may stall.) 1: Deceleration time 1 (the deceleration time for the stall prevention function is C1-02.)	0 to 2	1	No	A	A	No	No	No
	StallP Run Sel	2: Deceleration time 2 (the deceleration time for the stall prevention function is C1-04.)								
L3-06	Stall preven- tion level dur- ing running	Effective when L3-05 is 1 or 2. Set as a percentage of the Inverter rated current. Usually setting is not necessary.	30 to 200	160%	No	A	A	No	No	No
	StallP Run Level	The factory setting reduces the set values when the motor stalls.								

◆ Changing Stall Prevention Level during Operation Using an Analog Input

If you set H3-09 (Multi-function Analog Input Terminal A2 Function Selection) or H3-05 (Multi-function Analog Input Terminal A3 Function Selection) to 8 (stall prevention level during run), you can change the stall level during operation by setting H3-10 (Gain (Terminal A2)) and H3-11 (Bias (Terminal A2)) or H3-06 (Gain (Terminal A3)) and H3-07 (Bias (Terminal A3)).

The stall prevention level during operation enabled is the multi-function analog input terminal A2 or A3 input level or the set value in constant L3-06, whichever is the smaller.

Stall prevention level during operation

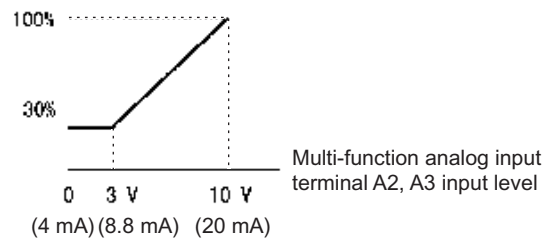

Fig 6.37 Stall Prevention Level during Operation Using an Analog Input



INFO

If the motor capacity is smaller than the Inverter capacity or the motor stalls when operating at the factory settings, lower the stall prevention level during operation.

◆ Detecting Motor Torque

If an excessive load is placed on the machinery (overtorque) or the load is suddenly lightened (undertorque), you can output an alarm signal to multi-function output terminal M1-M2, M3-M4, M5-M6, P3-C3, or P4-C4.

To use the overtorque/undertorque detection function, set B, 17, 18, 19 (overtorque/undertorque detection NO/NC) in one of the following constants: H2-01 to H2-05 (multi-function output terminals M1-M2, P1-PC, P2-PC, P3-C3, and P4-C4 function selection).

The overtorque/undertorque detection level is the current level (Inverter rated output current 100%) in V/f control, and the motor torque (motor rated torque 100%) in vector control.

■ Related Constants

Constant Number	Name	Description	Setting Range	Factory Setting	Change during Operation	Control Methods				
	Display					V/f	V/f with PG	Open Loop Vector 1	Flux Vector	Open Loop Vector 2
L6-01	Torque detection selection 1	0: Overtorque/undertorque detection disabled. 1: Overtorque detection only with speed agreement; operation continues after overtorque (warning). 2: Overtorque detected continuously during operation; operation continues after overtorque (warning). 3: Overtorque detection only with speed agreement; output stopped upon detection (protected operation). 4: Overtorque detected continuously during operation; output stopped upon detection (protected operation). 5: Undertorque detection only with speed agreement; operation continues after overtorque (warning). 6: Undertorque detected continuously during operation; operation continues after overtorque (warning). 7: Undertorque detection only with speed agreement; output stopped upon detection (protected operation). 8: Undertorque detected continuously during operation; output stopped upon detection (protected operation).	0 to 8	0	No	A	A	A	A	A
	Torq Det 1 Sel									
L6-02	Torque detection level 1	Open-loop vector control: Motor rated torque is set as 100%. V/f control: Inverter rated current is set as 100%.	0 to 300	150%	No	A	A	A	A	A
	Torq Det 1 Lvl									
L6-03	Torque detection time 1	Sets the overtorque/undertorque detection time in 1-second units.	0.0 to 10.0	0.1 s	No	A	A	A	A	A
	Torq Det 1 Time									
L6-04	Torque detection selection 2	Multi-function output for overtorque detection 1 is output to multi-function contact output when overtorque detection 1 NO or overtorque detection 1 NC is selected.	0 to 8	0	No	A	A	A	A	A
	Torq Det 2 Sel									
L6-05	Torque detection level 2	Multi-function output for overtorque detection 2 is output to multi-function contact output when overtorque detection 2 NO or overtorque detection 2 NC is selected.	0 to 300	150%	No	A	A	A	A	A
	Torq Det 2 Lvl									
L6-06	Torque detection time 2		0.0 to 10.0	0.1 s	No	A	A	A	A	A
	Torq Det 2 Time									

Multi-function Output (H2-01 to H2-05)

Setting Value	Function	Control Methods				
		V/f	V/f with PG	Open Loop Vector 1	Flux Vector	Open Loop Vector 2
B	Overtorque/undertorque detection 1 NO (NO contact: Overtorque/undertorque detection at ON)	Yes	Yes	Yes	Yes	Yes
17	Overtorque/undertorque detection 1 NC (NC Contact: Torque detection at OFF)	Yes	Yes	Yes	Yes	Yes
18	Overtorque/undertorque detection 2 NO (NO Contact: Torque detection at ON)	Yes	Yes	Yes	Yes	Yes
19	Overtorque/undertorque detection 2 NC (NC Contact: Torque detection at OFF)	Yes	Yes	Yes	Yes	Yes

■ L6-01 and L6-04 Set Values and LCD Indications

The relationship between alarms displayed by the Digital Operator when overtorque or undertorque is detected, and the set values in L6-01 and L6-04, is shown in the following table.

Set Value	Function	LCD Indications	
		Overtorque/Undertorque Detection 1	Overtorque/Undertorque Detection 2
0	Overtorque/undertorque detection disabled.	-	-
1	Overtorque detection only with speed matching; operation continues after overtorque (warning).	OL3 flashes	OL4 flashes
2	Overtorque detected continuously during operation; operation continues after overtorque (warning).	OL3 flashes	OL4 flashes
3	Overtorque detection only with speed matching; output stopped upon detection (protected operation).	OL3 lit	OL4 lit
4	Overtorque detected continuously during operation; output stopped upon detection (protected operation).	OL3 lit	OL4 lit
5	Undertorque detection only with speed matching; operation continues after overtorque (warning).	UL3 flashes	UL4 flashes
6	Undertorque detected continuously during operation; operation continues after overtorque (warning).	UL3 flashes	UL4 flashes
7	Undertorque detection only with speed matching; output stopped upon detection (protected operation).	UL3 lit	UL4 lit
8	Undertorque detected continuously during operation; output stopped upon detection (protected operation).	UL3 lit	UL4 lit

■ Setting Example

The following diagram shows the time chart for overtorque and undertorque detection.

- Overtorque Detection

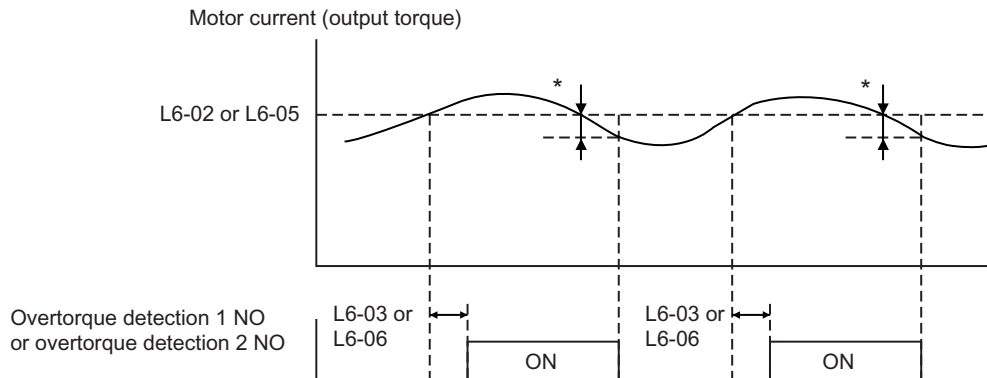

* Overtorque detection disabled band is approximately 10% of the Inverter rated output current (or motor rated torque).

- Undertorque Detection

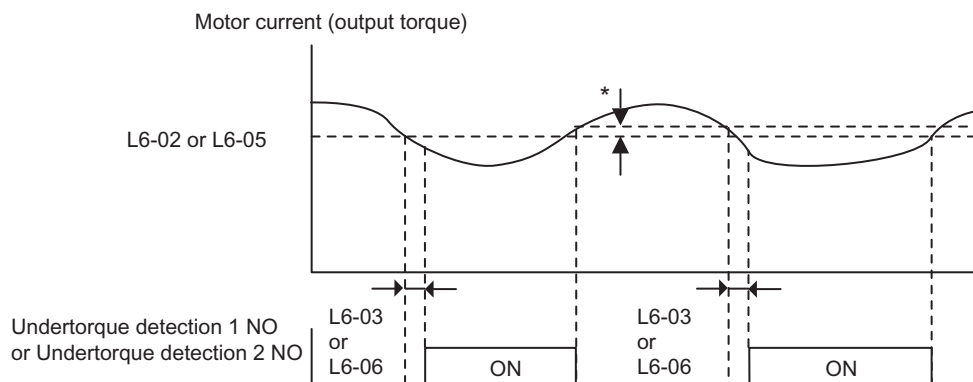

* The undertorque detection disabled margin is approximately 10% of the Inverter rated output current (or motor rated torque)

◆ Changing Overtorque and Undertorque Detection Levels Using an Analog Input

If you set constant H3-09 (Multi-function Analog Input Terminal A2 Function Selection) or H3-05 (Multi-function Analog Input Terminal A3 Function Selection) to 7 (overtorque/undertorque detection level), you can change the overtorque/undertorque detection level.

If you change the overtorque/undertorque detection level using the multi-function analog input, only overtorque/undertorque detection level 1 will be enabled.

The following diagram shows the overtorque/undertorque detection level using an analog input.

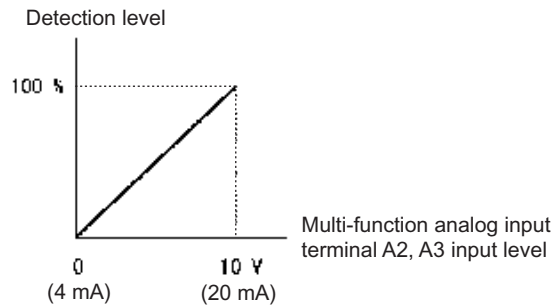

Fig 6.38 Overtorque/Undertorque Detection Level Using an Analog Input

Multi-Function Analog Input (H3-05, H3-09)

Setting Value	Function	Contents (100%)	Control Methods				
			V/f	V/f with PG	Open Loop Vector 1	Flux Vector	Open Loop Vector 2
7	Overtorque/undertorque detection level	Motor rated torque for vector control Inverter rated output current for V/f control	Yes	Yes	Yes	Yes	Yes

◆ Motor Overload Protection

You can protect the motor from overload using the Inverter's built-in electronic thermal overload relay.

■ Related Constants

Constant Number	Name	Description	Setting Range	Factory Setting	Change during Operation	Control Methods				
	Display					V/f	V/f with PG	Open Loop Vector 1	Flux Vector	Open Loop Vector 2
E2-01	Motor rated current	Sets the motor rated current in 1 A units.	0.32 to 6.40 *2	1.90 A *1	No	Q	Q	Q	Q	Q
	Motor Rated FLA	These set values will become the reference values for motor protection, torque limits and torque control. This constant is automatically set during autotuning.								
E4-01	Motor 2 rated current	Sets the motor rated current in 1 A units.	0.32 to 6.40 *2	1.90 A *1	No	A	A	A	A	A
	Motor Rated FLA	These set values will become the reference values for motor protection, torque limits and torque control. This constant is automatically set during autotuning.								
L1-01	Motor protection selection	Sets whether the motor overload function is enabled or disabled at electric thermal overload relay.	0 to 3	1	No	Q	Q	Q	Q	Q
	MOL Fault Select	0: Disabled 1: General-purpose motor protection 2: Inverter motor protection 3: Vector motor protection In some applications when the Inverter power supply is turned off, the thermal value is reset, so even if this constant is set to 1, protection may not be effective. When several motors are connected to one Inverter, set to 0 and ensure that each motor is installed with a protection device.								
L1-02	Motor protection time constant	Sets the electric thermal detection time in seconds units. Usually setting is not necessary. The factory setting is 150% overload for one minute.	0.1 to 5.0	1.0 min	No	A	A	A	A	A
	MOL Time Const	When the motor's overload resistance is known, also set the overload resistance protection time for when the motor is hot started.								

* 1. Factory settings depend on Inverter capacity. (The values shown are for a 200 V Class Inverter for 0.4 kW.)

* 2. The settings range is 10% to 200% of the Inverter rated output current. (The values shown are for a 200 V Class Inverter for 0.4 kW.)

Multi-Function Outputs (H2-01 to H2-05)

Setting Value	Function	Control Methods				
		V/f	V/f with PG	Open Loop Vector 1	Flux Vector	Open Loop Vector 2
1F	Motor overload (OL1, including OH3) pre-alarm (ON: 90% or more of the detection level)	Yes	Yes	Yes	Yes	Yes

■ Setting Motor Rated Current

Set the rated current value on the motor nameplate in constants E2-01 (for motor 1) and E4-01 (for motor 2). This set value is the electronic thermal base current.

■ Setting Motor Overload Protection Characteristics

Set the overload protection function in L1-01 according to the applicable motor.

The induction motor's cooling abilities differ according to the speed control range. Consequently, you must select the electronic thermal protection characteristics to match the applicable motor's tolerance load characteristics.

The following table shows the motor type and tolerance load characteristics.

L1-01 Set Value	Motor Type	Tolerance Load Characteristics	Cooling Ability	Electronic Thermal Operation (at 100% Motor Load)
1	General-purpose motor (standard motor)		Use this motor for operations using a commercial power supply. This motor construction yields best cooling effect when operating at 50/60 Hz.	When operating continuously at 50/60 Hz or less, motor overload detection (OL1) is detected. The Inverter outputs the error contact, and the motor coasts to a stop.
2	Inverter motor (constant torque) (1:10)		This motor yields a cooling effect even when operating at low speeds (approx. 6 Hz).	Operates continuously at 6 to 50/60 Hz.

L1-01 Set Value	Motor Type	Tolerance Load Characteristics	Cooling Ability	Electronic Thermal Operation (at 100% Motor Load)
3	Vector motor (1:100)		This motor yields a cooling effect even when operating at extremely low speeds (approx. 0.6 Hz).	Operates continuously at 0.6 to 60 Hz.

◆ Setting Motor Protection Operation Time

Set the motor protection operation time in L1-02.

If, after operating the motor continuously at the rated current, a 150% overload is experienced, set the (hot start) electronic thermal protection operation time. The factory setting is resistance to 150% for 60 seconds.

The following diagram shows an example of the characteristics of the electronic thermal protection operation time (L1-02 = 1.0 min., operation at 60 Hz, general-purpose motor characteristics, when L1-01 is set to 1)

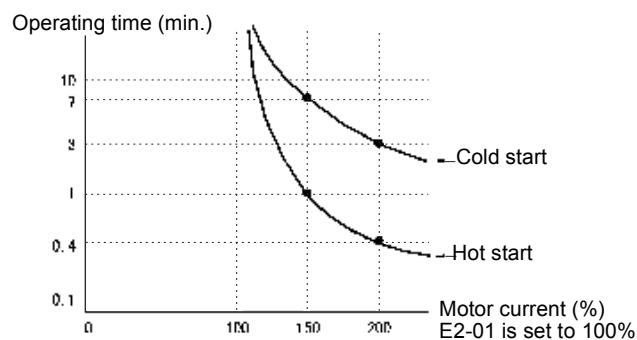

Fig 6.39 Motor Protection Operation Time

■ Setting Precautions

- If multiple motors are connected to one Inverter, set constant L1-01 to 0 (disabled). To protect the motor, install a thermal relay in the motor power cable, and perform overload protection on each motor.
- With applications where the power supply is often turned ON and OFF, there is a risk that the circuit cannot be protected even if this constant has been set to 1 (enabled), because the thermal value will be reset.
- To detect overloads in good time, set the set value in constant L1-02 to a low setting.
- When using a general-purpose motor (standard motor), the cooling ability will be lowered by $f^{1/4}$ (frequency). Consequently, the frequency may cause motor overload protection (OL1) to occur, even below the rated current. If operating using the rated current at a low frequency, use a special motor.

■ Setting the Motor Overload Pre-Alarm

If the motor overload protection function is enabled (i.e., L1-01 is set to other than 0) and you set H2-01 to H2-05 (multi-function output terminals M1-M2, M3-M4, M5-M6, P3-C3, and P4-C4 function selection) to 1F (motor overload OL1 pre-alarm), the motor overload pre-alarm will be enabled. If the electronic thermal value reaches minimum 90% of the overload detection level, the output terminal that has been set will be turned ON.

◆ Motor Overheating Protection Using PTC Thermistor Inputs

Perform motor overheating protection using the thermistor temperature resistance characteristics of the PTC (Positive Temperature Coefficient) built into the windings of each motor phase.

■ Related Constants

Con- stant Number	Name	Description	Setting Range	Factory Setting	Change during Opera- tion	Control Methods				
	Display					V/f	V/f with PG	Open Loop Vector 1	Flux Vec- tor	Open Loop Vector 2
L1-03	Alarm opera- tion selection during motor overheating	Set H3-09 to E and select the opera- tion when the input motor tempera- ture (thermistor) input exceeds the alarm detection level (1.17 V). 0: Decelerate to stop 1: Coast to stop 2: Emergency stop using the deceleration time in C1-09. 3: Continue operation (H3 on the Operator flashes).	0 to 3	3	No	A	A	A	A	A
	MOL Thm Input									
L1-04	Motor over- heating opera- tion selection	Set H3-09 to E and select the opera- tion when the motor temperature (thermistor) input exceeds the opera- tion detection level (2.34 V). 0: Decelerate to stop 1: Coast to stop 2: Emergency stop using the deceleration time in C1-09.	0 to 2	1	No	A	A	A	A	A
	MOL Filter Time									
L1-05	Motor tem- perature input filter time constant	Set H3-09 to E and set the primary delay time constant for motor tem- perature (thermistor) inputs in sec- onds.	0.00 to 10.00	0.20 s	No	A	A	A	A	A
	MOL Filter Time									

■ PTC Thermistor Characteristics

The following diagram shows the characteristics of the PTC thermistor temperature to the resistance value.

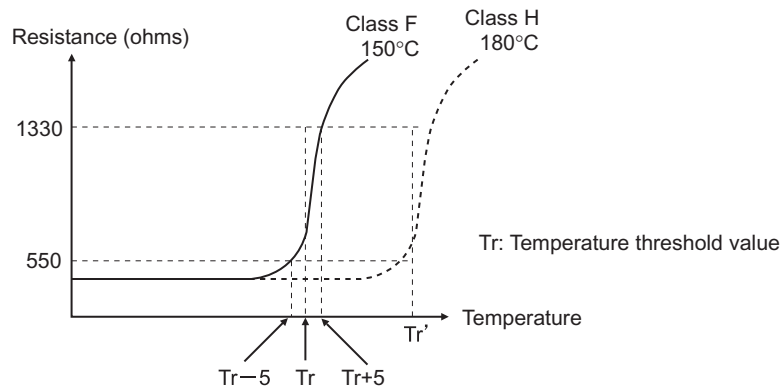

Fig 6.40 PTC Thermistor Temperature-Resistance Value Characteristics

■ Operation during Motor Overheating

Set the operation if the motor overheats in constants L1-03 and L1-04. Set the motor temperature input filter time constant in L1-05. If the motor overheats, the OH3 and OH4 error codes will be displayed on the Digital Operator.

Error Codes If the Motor Overheats

Error Code	Details
OH3	Inverter stops or continues to operate, according to the setting in L1-03.
OH4	Inverter stops according to the setting in L1-04.

By setting H3-09 (Multi-function Analog Input Terminal A2 Function Selection) or H3-05 (Multi-function Analog Input Terminal A3 Function Selection) to E (Motor temperature input), you can detect alarm OH3 or OH4 using the PTC temperature-resistance characteristics, and protect the motor. The terminal connections are shown in the following diagram.

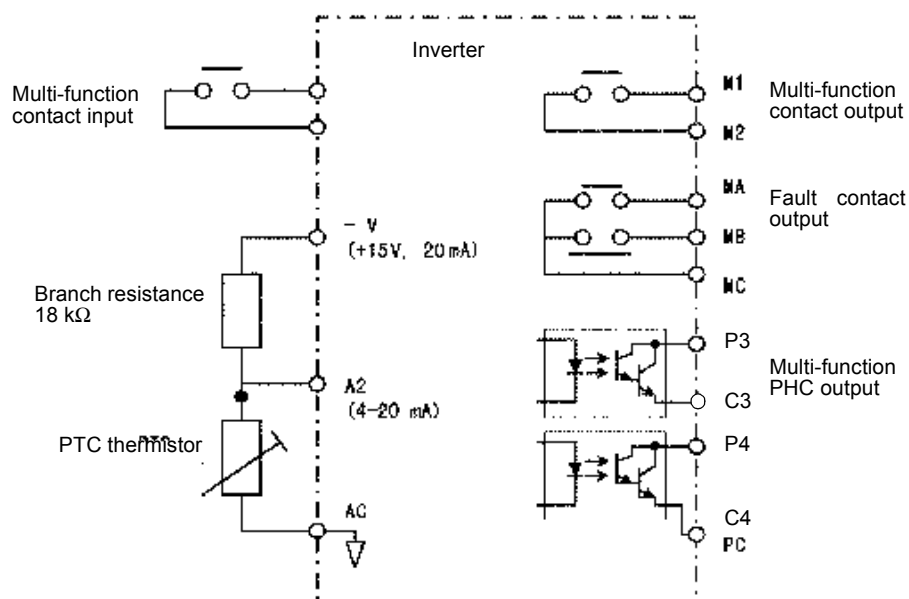

Fig 6.41 Mutual Connections During Motor Overheating Protection

◆ Limiting Motor Rotation Direction

If you set motor reverse rotation prohibited, a reverse run command will not be accepted even if it is input. Use this setting for applications in which reverse motor rotation can cause problems (e.g., fans, pumps, etc.)

■ Related Constants

Constant Number	Name	Description	Setting Range	Factory Setting	Change during Operation	Control Methods				
	Display					V/f	V/f with PG	Open Loop Vector 1	Flux Vector	Open Loop Vector 2
b1-04	Prohibition of reverse operation	0: Reverse enabled 1: Reverse disabled	0 or 1	0	No	A	A	A	A	A
	Reverse Oper									

Continuing Operation

This section explains functions for continuing or automatically restarting Inverter operation even if an error occurs.

◆ Restarting Automatically After Power Is Restored

Even if a temporary power loss occurs, you can restart the Inverter automatically after power is restored to continue motor operation.

To restart the Inverter after power is restored, set L2-01 to 1 or 2.

If L2-01 is set to 1, when power is restored within the time set in L2-02, the Inverter will restart. If the time set in L2-02 is exceeded, alarm UV1 (main circuit undervoltage) will be detected.

If L2-01 is set to 2, when the main power supply is restored while the control power supply (i.e., power supply to the control panel) is backed up, the Inverter will restart. Consequently, alarm UV1 (main circuit undervoltage) will not be detected.

■ Related Constants

Con- stant Number	Name	Description	Setting Range	Factory Setting	Change during Opera- tion	Control Methods				
	Display					V/f	V/f with PG	Open Loop Vector 1	Flux Vec- tor	Open Loop Vector 2
L2-01	Momentary power loss detection	0: Disabled (main circuit undervoltage (UV) detection) 1: Enabled (Restarted when the power returns within the time for L2-02. When L2-02 is exceeded, main circuit undervoltage detection.) 2: Enabled while CPU is operating. (Restarts when power returns during control operations. Does not detect main circuit undervoltage.)	0 to 2	0	No	A	A	A	A	A
	PwrL Selec- tion									
L2-02	Momentary power loss ridethru time	Ridethrough time, when Momentary Power Loss Selection (L2-01) is set to 1, in units of seconds.	0 to 25.5	0.1 s *	No	A	A	A	A	A
	PwrL Ride- thru t									
L2-03	Min. base- block time	Sets the Inverter's minimum base-block time in units of one second, when the Inverter is restarted after power loss ridethrough. Sets the time to approximately 0.7 times the motor secondary circuit time constant. When an overcurrent or overvoltage occurs when starting a speed search or DC injection braking, increase the set values.	0.1 to 5.0	0.2 s *1	No	A	A	A	A	A
	PwrL Base- block t									
L2-04	Voltage recovery time	Sets the time required to return the Inverter output voltage to normal voltage at the completion of a speed search, in units of one second. Sets the time required to recover from 0 V to the maximum voltage.	0.0 to 5.0	0.3 s *1	No	A	A	A	A	A
	PwrL V/F Ramp t									

Constant Number	Name	Description	Setting Range	Factory Setting	Change during Operation	Control Methods				
	Display					V/f	V/f with PG	Open Loop Vector 1	Flux Vector	Open Loop Vector 2
L2-05	Undervoltage detection level	Sets the main circuit undervoltage (UV) detection level (main circuit DC voltage) in V units. Usually setting is not necessary.	150 to 210 *2	190 V *2	No	A	A	A	A	A
	PUV Det Level	Insert an AC reactor in the Inverter input side to lower the main circuit undervoltage detection level.								

* 1. Factory settings depend on Inverter capacity. (The values shown are for a 200 V Class Inverter for 0.4 kW.)

* 2. These values are for a 200 V Class Inverter. For a 400 V Class Inverter, double the values.

■ Setting Precautions

- Error output signals are not output during momentary power loss recovery.
- To continue Inverter operation after power has been restored, make settings so that run commands from the control main circuit terminal are stored even while power is suspended.
- If the momentary power loss operation selection is set to 0 (Disabled), when the momentary power loss exceeds 15 ms during operation, alarm UV1 (main circuit undervoltage) will be detected.

◆ Speed Search

The speed search function finds the actual speed of the motor that is rotating using inertia, and then starts smoothly from that speed. When restoring power after a temporary power loss, the speed search function switches connection from the commercial power supply, and then restarts the fan that is rotating using inertia.

■ Related Constants

Constant Number	Name	Description	Setting Range	Factory Setting	Change during Operation	Control Methods				
	Display					V/f	V/f with PG	Open Loop Vector 1	Flux Vector	Open Loop Vector 2
b3-01	Speed search selection (current detection or speed calculation)	<p>Enables/disables the speed search function for the run command and sets the speed search method.</p> <p>0: Disabled, speed calculation 1: Enabled, speed calculation 2: Disabled, current detection 3: Enabled, current detection</p> <p>Speed Calculation: When the search is started, the motor speed is calculated and acceleration/deceleration is performed from the calculated speed to the specified frequency (motor direction is also searched).</p> <p>Current Detection: The speed search is started from the frequency when power was momentarily lost and the maximum frequency, and the speed is detected at the search current level.</p>	0 to 3	2*1	No	A	A	A	No	A
	SpdSrch at Start									

Con-stant Number	Name	Description	Setting Range	Factory Setting	Change during Operation	Control Methods				
	Display					V/f	V/f with PG	Open Loop Vector 1	Flux Vector	Open Loop Vector 2
b3-02	Speed search operating current (current detection)	Sets the speed search operation current as a percentage, taking the Inverter rated current as 100%. Not usually necessary to set. When restarting is not possible with the factory settings, reduce the value.	0 to 200	100%*1	No	A	No	A	No	A
	SpdSrch Current									
b3-03	Speed search deceleration time (current detection)	Sets the output frequency deceleration time during speed search in 1-second units. Set the time for deceleration from the maximum output frequency to the minimum output frequency.	0.1 to 10.0	2.0 s	No	A	No	A	No	No
	SpdSrch Dec Time									
b3-05	Speed search wait time (current detection or speed calculation)	Sets the contactor operating delay time when there is a contactor on the output side of the Inverter. When a speed search is performed after recovering from a momentary power loss, the search operation is delayed by the time set here.	0.0 to 20.0	0.2 s	No	A	A	A	A	A
	Search Delay									
L2-03	Min. base-block time	Sets the Inverter's minimum base-block time in units of one second, when the Inverter is restarted after power loss ridethrough. Sets the time to approximately 0.7 times the motor secondary circuit time constant. When an overcurrent or overvoltage occurs when starting a speed search or DC injection braking, increase the set values.	0.1 to 5.0	0.5 s *2	No	A	A	A	A	A
	PwrL Base-block t									
L2-04	Voltage recovery time	Sets the time required to return the Inverter output voltage to normal voltage at the completion of a speed search, in units of one second. Sets the time required to recover from 0 V to the maximum voltage.	0.0 to 5.0	0.3 s *2	No	A	A	A	A	A
	PwrL V/F Ramp t									

* 1. The factory setting will change when the control method is changed. (Open-loop vector control 1 factory settings are given.)

* 2. Factory settings depend on Inverter capacity. (The values shown are for a 200 V Class Inverter for 0.4 kW.)

Multi-function Contact Inputs (H1-01 to H1-10)

Set-ting Value	Function	Control Methods				
		V/f	V/f with PG	Open Loop Vector 1	Flux Vector	Open Loop Vector 2
61	External search command 1 (ON: Speed search from maximum output frequency)	Yes	No	Yes	No	Yes
62	External search command 2 (ON: Speed search from set frequency)	Yes	No	Yes	No	Yes

■ Setting Precautions

- When both external search commands 1 and 2 are set for the multi-function contact terminals, an OPE03 (invalid multi-function input selection) operation error may occur. Set either external search command 1 or external search command 2.
- If speed search during startup is selected when using V/f control with PG, the Unit will start from the frequency detected by PG.
- If performing speed search using external search commands, add an external sequence so that the period when the run command and external search command are both ON is at the very least the Minimum Baseblock Time (L2-03).
- If the Inverter output is equipped with a contact, set the contact operation delay time in the Speed Search Wait Time (b3-05). The factory setting is 0.2 s. When not using the contact, you can reduce the search time by making the setting 0.0 s. After waiting for the speed search wait time, the Inverter starts the speed search.
- Constant b3-02 is a current detection speed search (current detection level for search completion). When the current falls below the detection level, the speed search is viewed as completed, and the motor accelerates or decelerates to the set frequency. If the motor cannot restart, lower the set value.
- If an overcurrent (OC) is detected when using speed search after recovery following a power loss, lengthen the Minimum Baseblock Time (L2-03).

■ Application Precautions for Speed Searches Using Estimated Speed

- When using V/f control with or without a PG, always perform stationary autotuning for only line-to-line resistance before using speed searches based on estimated speeds.
- When using open-loop vector control, always perform rotational autotuning before using speed searches based on estimated speeds.
- If the cable length between the motor and Inverter is changed after autotuning has been performed, perform stationary autotuning for only line-to-line resistance again.



The motor will not operate when stationary autotuning or stationary autotuning only for line-to-line resistance is performed.

■Speed Search Selection

Set whether to enable or disable speed search at startup, and set the type of speed search (estimated speed or current detection) using setting b3-01. To perform speed search when inputting the run command, set b3-01 to 1 or 3.

Search Name	Estimated Speed	Current Detection
Search Method	Estimates the motor speed when the search starts, and accelerates and decelerates from the estimated speed to the set frequency. You can also search including direction of motor rotation.	Starts speed search from the frequency when the temporary power loss was detected, or from the highest frequency, and performs speed detection at the current level during the search.
External Speed Search Command	External search command 1 and external search command 2 become the same operation, estimating the motor speed and starting the search from the estimated speed.	External speed search command 1: Starts speed search from the maximum output frequency. External speed search command 2: Starts speed search from the frequency reference set before the search command.
Application Precautions	Cannot be used multi-motor drives, motors two or more frames smaller than the Inverter capacity, and high-speed motors (130 Hz min.)	In control method without PG, the motor may accelerate suddenly with light loads.

■Estimated Speed Search

The time chart for estimated speed searches is shown below.

Search at Startup

The time chart for when speed search at startup and speed search to multi-function input terminals is shown below.

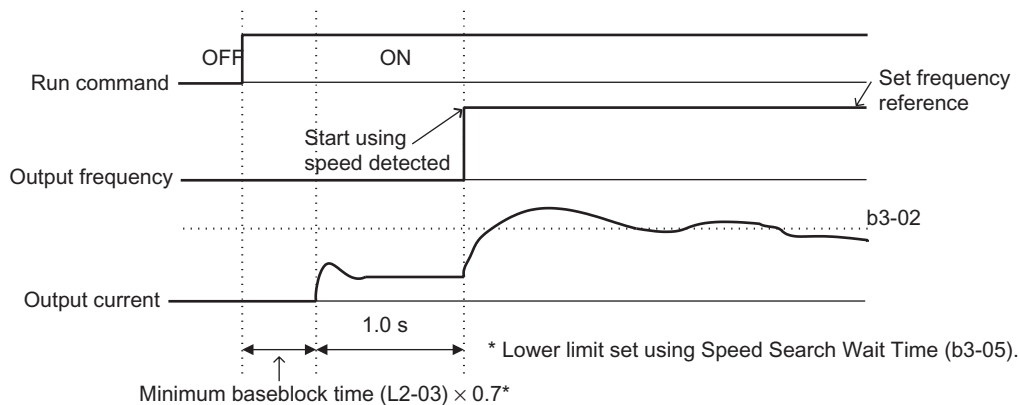

Note: If the stopping method is set to coast to stop, and the run command turns ON in a short time, the operation may be the same as the search in case 2.

Fig 6.42 Speed Search at Startup (Estimated Speed)

Speed Search after Short Baseblock (during Power Loss Recovery, etc.)

- Loss Time Shorter Than the Minimum Baseblock Time (L2-03)

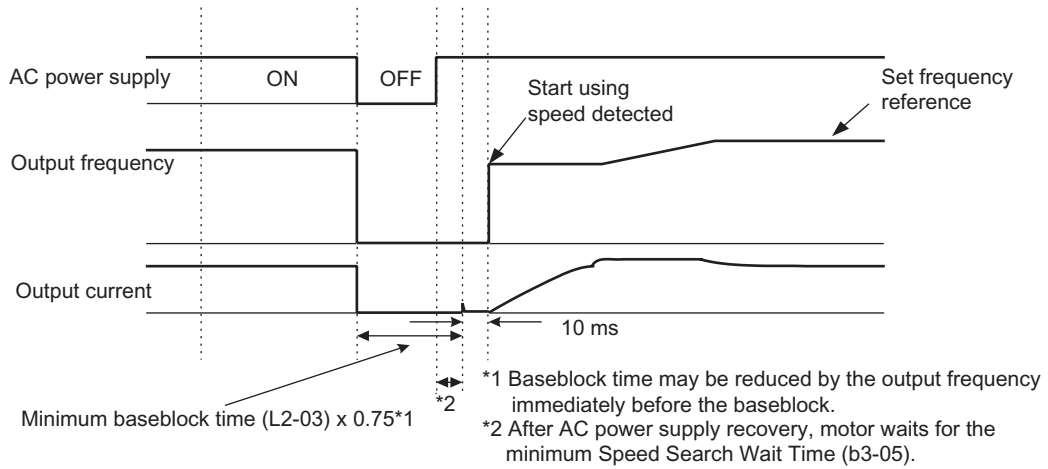

Fig 6.43 Speed Search after Baseblock (When Estimated Speed: Loss Time Is Set in L2-03)

- Loss Time Longer Than the Minimum Baseblock Time (L2-03)

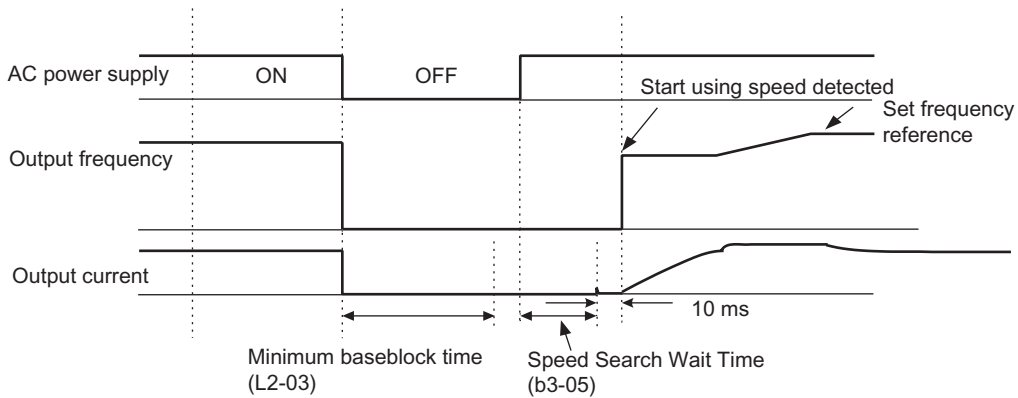

Fig 6.44 Speed Search After Baseblock (Estimated Speed: Loss Time > L2-03)

■ Current Detection Speed Search

The time charts for current detection speed search is shown below.

Speed Search at Startup

The time chart when speed search at startup or external speed search command is selected is shown below.

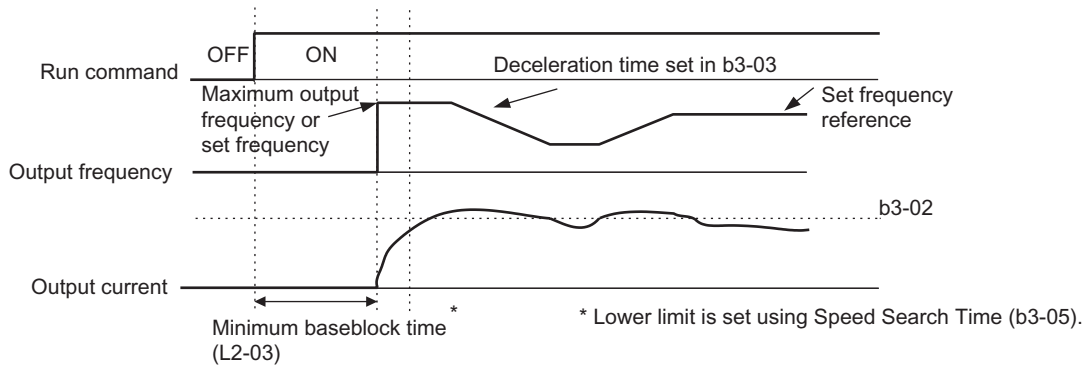

Fig 6.45 Speed Search at Startup (Using Current Detection)

Speed Search after Short Baseblock (during Power Loss Recovery, etc.)

- Loss Time Shorter Than Minimum Baseblock Time

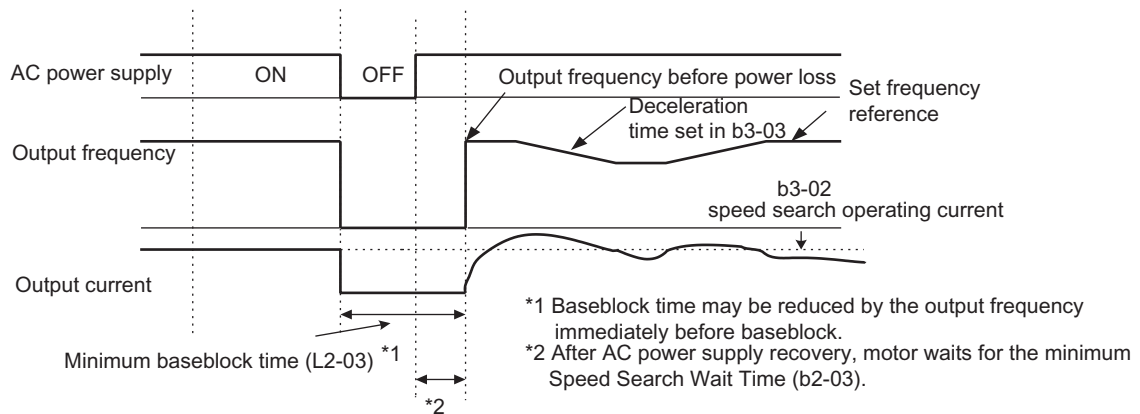

Fig 6.46 Speed Search After Baseblock (Current Detection: Loss Time < L2-03)

- Loss Time Longer Than Minimum Baseblock Time

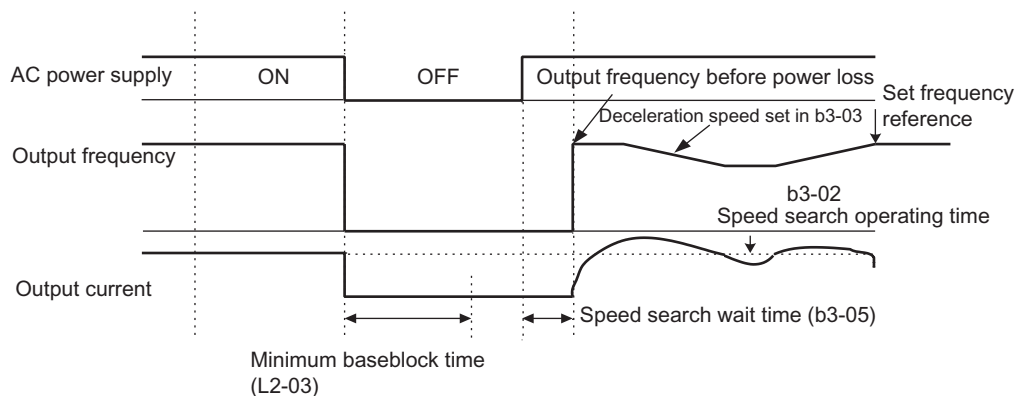

Fig 6.47 Speed Search After Baseblock (Current Detection: Loss Time > L2-03)

◆ Continuing Operation at Constant Speed When Frequency Reference Is Lost

The frequency reference loss detection function continues operation using 80% speed of the frequency reference before loss when the frequency reference using an analog input is reduced 90% or more in 400 ms.

When the error signal during frequency reference loss is output externally, set H2-01 to H2-05 (multi-function contact output terminal M1-M2, M3-M4, M5-M6, P3-C3, and P4-C4 function selection) to C (frequency reference lost).

■ Related Constants

Constant Number	Name	Description	Setting Range	Factory Setting	Change during Operation	Control Methods				
	Display					V/f	V/f with PG	Open Loop Vector 1	Flux Vector	Open Loop Vector 2
L4-05	Operation when frequency reference is missing	0: Stop (Operation follows the frequency reference.) 1: Operation at 80% speed continues. (At 80% of speed before the frequency reference was lost)	0 or 1	0	No	A	A	A	A	A
	Ref Loss Sel	Frequency reference is lost: Frequency reference dropped over 90% in 400 ms.								

◆ Restarting Operation After Transient Error (Auto Restart Function)

If an Inverter error occurs during operation, the Inverter will perform self-diagnosis. If no error is detected, the Inverter will automatically restart. This is called the auto restart function.

Set the number of auto restarts in constant L5-01.

The auto restart function can be applied to the following errors. If an error not listed below occurs, the protection function will operate and the auto restart function will not.

- OC (Overcurrent)
- GF (Ground fault)
- PUF (Fuse blown)
- OV (Main circuit overvoltage)
- UV1 (Main Circuit Undervoltage, Main Circuit MC Operation Failure)*
- PF (Main circuit voltage fault)
- LF (Output phase failure)
- RH (Braking resistor overheated)
- RR (Braking transistor error)
- OL1 (Motor overload)
- OL2 (Inverter overload)
- OH1 (Motor overheat)
- OL3 (Overtorque)
- OL4 (Overtorque)

* When L2-01 is set to 1 or 2 (continue operation during momentary power loss)

■ Auto Restart External Outputs

To output auto restart signals externally, set H2-01 to H2-05 (multi-function contact output terminals M1-M2, M3-M4, M5-M6, P3-C3, and P4-C4 function selection) to 1E (auto restart).

■ Related Constants

Con- stant Number	Name	Description	Setting Range	Factory Setting	Change during Opera- tion	Control Methods				
	Display					V/f	V/f with PG	Open Loop Vector 1	Flux Vec- tor	Open Loop Vector 2
L5-01	Number of auto restart attempts	Sets the number of auto restart attempts. Automatically restarts after a fault and conducts a speed search from the run frequency.	0 to 10	0	No	A	A	A	A	A
	Num of Restarts									
L5-02	Auto restart operation selection	Sets whether a fault contact output is activated during fault restart. 0: Not output (Fault contact is not activated.) 1: Output (Fault contact is activated.)	0 or 1	0	No	A	A	A	A	A
	Restart Sel									

■ Application Precautions

- The number of auto restarts count is reset under the following conditions:
 - After auto restart, normal operation has continued for 10 minutes.
 - After the protection operation has been performed, and the error has been verified, and an fault reset has been input.
 - After the power supply is turned OFF, and then ON again.
- Do not use the auto restart function with variable loads.

Inverter Protection

This section explains the functions for protecting the Inverter and the braking resistor.

◆ Performing Overheating Protection on Mounted Braking Resistors

Perform overheating protection on Inverter-mounted braking resistors (Model: ERF-150WJ □□).

When overheating in a mounted braking resistor is detected, an alarm RH (Mounted braking resistor overheating) is displayed on the Digital Operator, and the motor coasts to a stop.

■ Related Constants

Constant Number	Name	Description	Setting Range	Factory Setting	Change during Operation	Control Methods				
	Display					V/f	V/f with PG	Open Loop Vector 1	Flux Vector	Open Loop Vector 2
L8-01	Protect selection for internal DB resistor (Type ERF)	0: Disabled (no overheating protection) 1: Enabled (overheating protection)	0 or 1	0	No	A	A	A	A	A
	DB Resistor Prot									

Multi-function Contact Outputs (H2-01 to H2-05)

Setting Value	Function	Control Methods				
		V/f	V/f with PG	Open Loop Vector 1	Flux Vector	Open Loop Vector 2
D	Braking resistor fault (ON: Resistor overheat or braking transistor fault)	Yes	Yes	Yes	Yes	Yes



INFO

The most likely causes of RH (Mounted braking resistor overheating) being detected are that the deceleration time is too short or that the motor regeneration energy is too large. In these cases, lengthen the deceleration time or replace the Braking Resistor Unit with one with a higher breaking capacity.

◆ Reducing Inverter Overheating Pre-Alarm Warning Levels

The Inverter detects the temperature of the cooling fins using the thermistor, and protects the Inverter from overheating. You can receive Inverter overheating pre-alarms in units of 10°C.

The following overheating pre-alarm warnings are available: Stopping the Inverter as error protection, and continuing operation, with the alarm OH (Radiation fins overheating) on the Digital Operator flashing.

■ Related Constants

Con- stant Number	Name	Description	Setting Range	Factory Setting	Change during Opera- tion	Control Methods				
	Display					V/f	V/f with PG	Open Loop Vector 1	Flux Vec- tor	Open Loop Vector 2
L8-02	Overheat pre- alarm level	Sets the detection temperature for the Inverter overheat detection pre-alarm in °C. The pre-alarm detects when the cooling fin temperature reaches the set value.	50 to 130	95 °C*	No	A	A	A	A	A
	OH Pre-Alarm Lvl									
L8-03	Operation selection after overheat pre- alarm	Sets the operation for when the Inverter overheat pre-alarm goes ON. 0: Decelerate to stop in deceleration time C1-02. 1: Coast to stop 2: Fast stop in fast-stop time C1-09. 3: Continue operation (Monitor display only.) A fault will be given in setting 0 to 2 and a minor fault will be given in setting 3.	0 to 3	3	No	A	A	A	A	A
	OH Pre-Alarm Sel									

* The factory setting depends upon the Inverter capacity. The value for 200 V Class Inverter of 0.4 kW is given.

Input Terminal Functions

This section explains input terminal functions, which set operating methods by switching functions for the multi-function contact input terminals (S3 to S12).

◆ Temporarily Switching Operation between Digital Operator and Control Circuit Terminals

You can switch the Inverter run command inputs and frequency reference inputs between local (i.e., Digital Operator) and remote (input method using b1-01 and b1-02).

You can switch between local and remote by turning ON and OFF the terminals if an output from H1-01 to H1-10 (multi-function contact input terminal S3 to S12 function selection) has been set to 1 (local/remote selection).

To set the control circuit terminals to remote, set b1-01 and b1-02 to 1 (Control circuit terminals).

■ Related Constants

Constant Number	Name	Description	Setting Range	Factory Setting	Change during Operation	Control Methods				
	Display					V/f	V/f with PG	Open Loop Vector 1	Flux Vector	Open Loop Vector 2
b1-01	Reference selection	Set the frequency reference input method. 0: Digital Operator 1: Control circuit terminal (analog input) 2: MEMOBUS communications 3: Option Card 4: Pulse train input	0 to 4	1	No	Q	Q	Q	Q	Q
	Reference Source									
b1-02	Operation method selection	Set the run command input method. 0: Digital Operator 1: Control circuit terminal (sequence input) 2: MEMOBUS communications 3: Option Card	0 to 3	1	No	Q	Q	Q	Q	Q
	Run Source									



INFO

You can also perform local/remote switching using the LOCAL/REMOTE Key on the Digital Operator. When the local/remote function has been set in the external terminals, the LOCAL/REMOTE Key function on the Digital Operator will be disabled.

◆ Blocking Inverter Outputs (Baseblock Commands)

Set 8 or 9 (Baseblock command NO/NC) in one of the constants H1-01 to H1-10 (multi-function contact input terminal S3 to S12 function selection) to perform baseblock commands using the terminal's ON/OFF operation, and prohibit Inverter output using the baseblock commands.

Clear the baseblock command to restart the operating using speed search from frequency references from the previous baseblock command input.

Multi-function Contact Inputs (H1-01 to H1-10)

Set-ting Value	Function	Control Methods				
		V/f	V/f with PG	Open Loop Vec-tor 1	Flux Vec-tor	Open Loop Vec-tor 2
8	External baseblock NO (NO contact: Baseblock at ON)	Yes	Yes	Yes	Yes	Yes
9	External baseblock NC (NC contact: Baseblock at OFF)	Yes	Yes	Yes	Yes	Yes

■ Time Chart

The time chart when using baseblock commands is shown below.

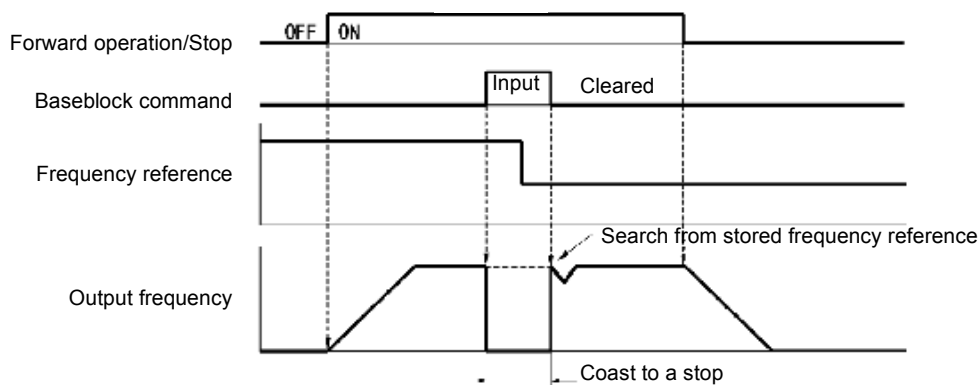

Fig 6.48 Baseblock Commands



If using baseblock commands with a variable load, do not frequently input baseblock commands during operation, as this may cause the motor to suddenly start coasting, and may result in the motor falling or slipping.

◆ Stopping Acceleration and Deceleration (Acceleration/Deceleration Ramp Hold)

The acceleration/deceleration ramp hold function stops acceleration and deceleration, stores the output frequency at that point in time, and then continues operation.

Set one of the constants H1-01 to H1-10 (multi-function contact input terminal S3 to S12 function selection) to A (acceleration/deceleration ramp hold) to stop acceleration and deceleration when the terminal is turned ON and to store the output frequency at that point in time. Acceleration and deceleration will restart when the terminal is turned OFF.

If d4-01 is set to 1 and the Acceleration/Deceleration Ramp Hold command is input, the output frequency is still stored even after the power supply is turned OFF.

■ Related Constants

Constant Number	Name	Description	Setting Range	Factory Setting	Change during Operation	Control Methods				
	Display					V/f	V/f with PG	Open Loop Vector 1	Flux Vector	Open Loop Vector 2
d4-01	Frequency reference hold function selection	Sets whether or not frequencies on hold will be recorded. 0: Disabled (when operation is stopped or the power is turned on again starts at 0.) 1: Enabled (when operation is stopped or the power is turned on again starts at the previous hold frequency.) This function is available when the multi-function inputs "accel/decel Ramp Hold" or "up/down" commands are set.	0 or 1	0	No	A	A	A	A	A
	MOP Ref Memory									

■ Time Chart

The time chart when using Acceleration/Deceleration Ramp Hold commands is given below.

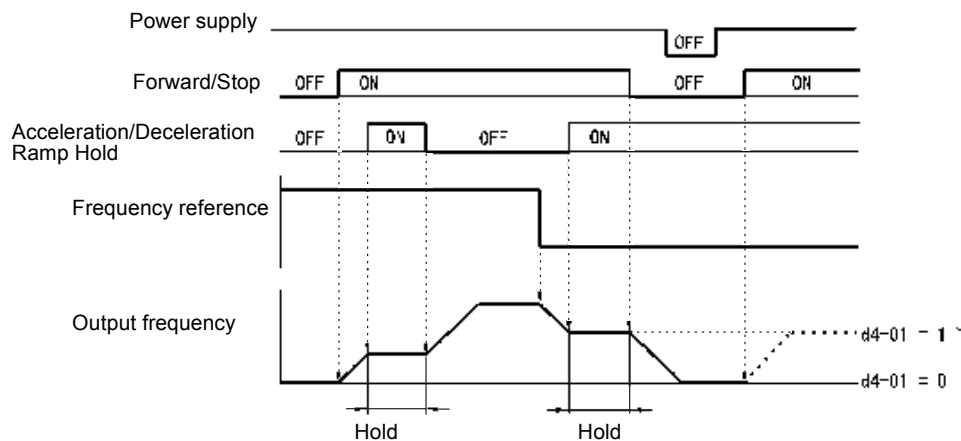

Fig 6.49 Acceleration/Deceleration Ramp Hold

■ Application Precautions

- When d4-01 is set to 1, the output frequency on hold is stored even after the power supply is turned OFF. If performing operations using this frequency after the Inverter has also been turned OFF, input the run command with the Acceleration/Deceleration Ramp Hold turned ON.
- When d4-01 is set to 0 and a run command is input while the Acceleration/Deceleration Ramp Hold is turned ON, the output frequency will be set to zero.
- If you input an Acceleration/Deceleration Ramp Hold command by error when decelerating during positioning, deceleration may be canceled.

◆ Raising and Lowering Frequency References Using Contact Signals (UP/DOWN)

The UP and DOWN commands raise and lower Inverter frequency references by turning ON and OFF a multi-function contact input terminal S3 to S7.

To use this function, set one of the constants H1-01 to H1-10 (multi-function contact input terminal S3 to S12 function selection) to 10 (UP command) and 11 (DOWN command). Be sure to allocate two terminals so that the UP and DOWN commands can be used as a pair.

The output frequency depends on the acceleration and deceleration time. Be sure to set b1-02 (Run command selection) to 1 (Control circuit terminal).

■ Related Constants

Constant Number	Name	Description	Setting Range	Factory Setting	Change during Operation	Control Methods				
	Display					V/f	V/f with PG	Open Loop Vector 1	Flux Vector	Open Loop Vector 2
d2-01	Frequency reference upper limit	Set the output frequency upper limit as a percent, taking the max. output frequency to be 100%.	0.0 to 110.0	100.0%	No	A	A	A	A	A
	Ref Upper Limit									
d2-02	Frequency reference lower limit	Sets the output frequency lower limit as a percentage of the maximum output frequency.	0.0 to 110.0	0.0%	No	A	A	A	A	A
	Ref Lower Limit									
d2-03	Master speed reference lower limit	Set the master speed reference lower limit as a percent, taking the max. output frequency to be 100%.	0.0 to 110.0	0.0%	No	A	A	A	A	A
	Ref1 Lower Limit									

■ Precautions

When setting and using UP and DOWN commands, observe the following precautions.

Setting Precautions

If multi-function input terminals S3 to S12 are set as follows, operation error OPE03 (Invalid multi-function input selection) will occur:

- Only either the UP command or DOWN command has been set.

- UP/DOWN commands and Acceleration/Deceleration Ramp Hold have been allocated at the same time.

Application Precautions

- Frequency outputs using UP/DOWN commands are limited by the frequency reference upper and lower limits set in constants d2-01 to d2-03. Here, frequency references from analog frequency reference terminal A1 becomes the frequency reference lower limit. If using a combination of the frequency reference from terminal A1 and the frequency reference lower limit set in either constant d2-02 or d2-03, the larger lower limit will become the frequency reference lower limit.
- If inputting the run command when using UP/DOWN commands, the output frequency accelerates to the frequency reference lower limit.
- When using UP/DOWN commands, multi-step operations are disabled.
- When d4-01 (Frequency Reference Hold Function Selection) is set to 1, the frequency reference held using the UP/DOWN functions is stored even after the power supply is turned OFF. When the power supply is turned ON and the run command is input, the motor accelerates to the frequency reference that has been stored. To reset (i.e., to 0 Hz) the stored frequency reference, turn ON the UP or DOWN command while the run command is ON.

■ Connection Example and Time Chart

The time chart and settings example when the UP command is allocated to the multi-function contact input terminal S3, and the DOWN command is allocated to terminal S4, are shown below.

Constant	Name	Set Value
H1-01	Multi-function input (terminal S3)	10
H1-02	Multi-function input (terminal S4)	11

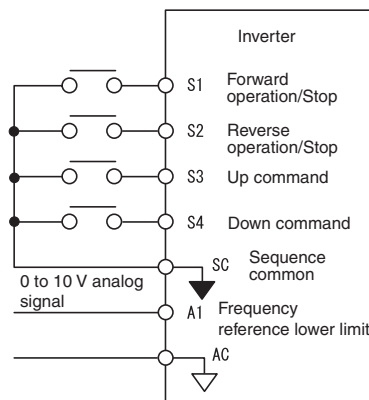
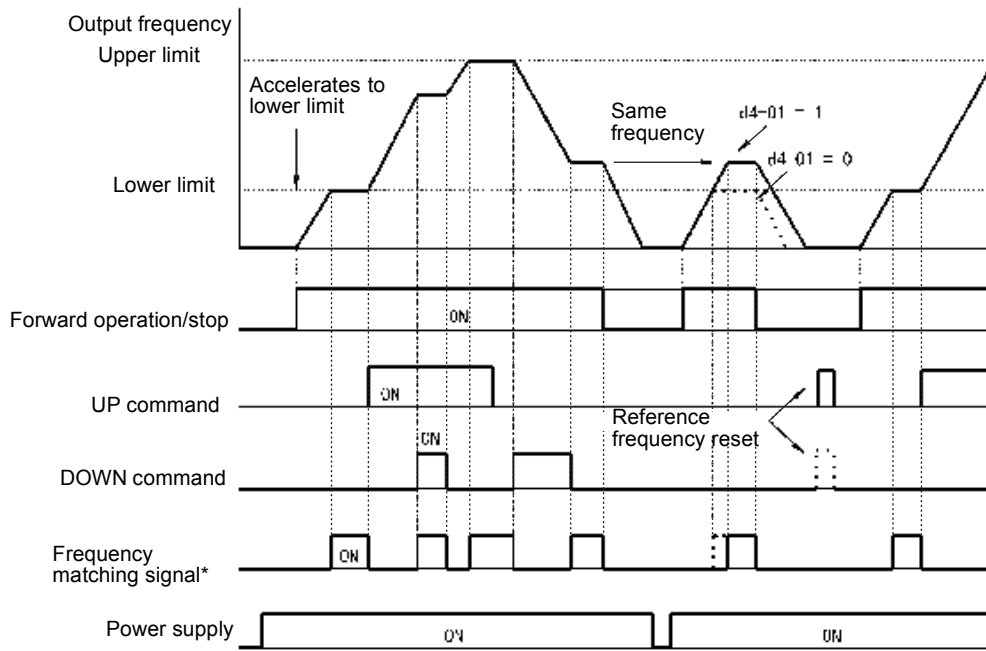

Fig 6.50 Connection Example when UP/DOWN Commands Are Allocated



* The frequency matching signal turns ON when the motor is not accelerating/ decelerating while the run command is ON.

Fig 6.51 UP/DOWN Commands Time Chart

◆ Accelerating and Decelerating Constant Frequencies in the Analog References (+/- Speed)

The +/- speed function increments or decrements the frequency set in analog frequency reference d4-02 (+/- Speed Limit) using two contact signal inputs.

To use this function, set One of the constants H1-01 to H1-10 (multi-function contact terminal inputs S3 to S12 function selection) to 1C (Trim Control Increase command) and 1D (Trim Control Decrease command). Be sure to allocate two terminals so that the Trim Control Increase command and Trim Control Decrease command can be used as a pair.

■ Related Constants

Constant Number	Name	Description	Setting Range	Factory Setting	Change during Operation	Control Methods				
	Display					V/f	V/f with PG	Open Loop Vector 1	Flux Vector	Open Loop Vector 2
d4-02	+ - Speed limits	Set the frequency to be add to or subtracted from the analog frequency reference as a percent, taking the maximum output frequency to be 100%. Enabled when the increase (+) speed command or decrease (-) speed command is set for a multi-function input.	0 to 100	10%	No	A	A	A	A	A
	Trim Control Lvl									

■ Trim Control Increase/Decrease Command and Frequency Reference

The frequency references using Trim Control Increase/Decrease command ON/OFF operations are shown below.

Frequency Reference	Set Frequency Reference + d4-02	Set Frequency Reference - d4-02	Set Frequency Command	
Trim Control Increase Command Terminal	ON	OFF	ON	OFF
Trim Control Decrease Command Terminal	OFF	ON	ON	OFF

■ Application Precautions

- Trim Control Increase/Decrease command is enabled when speed reference > 0 and the speed reference is from an analog input.
- When the analog frequency reference value - d4-02 < 0, the frequency reference is set to 0.
- If only the Trim Control Increase command or Trim Control Decrease command has been set for a multi-function contact input terminal S3 to S12, operation error OPE03 (invalid multi-function input selected) will occur.

◆ Hold Analog Frequency Using User-set Timing

When one of H1-01 to H1-10 (multi-function contact input terminal S3 to S12 function selection) is set to 1E (sample/hold analog frequency command), the analog frequency reference will be held from 100 ms after the terminal is turned ON, and operation will continue thereafter at that frequency.

The analog value 100 ms after the command is turned ON is used as the frequency reference.

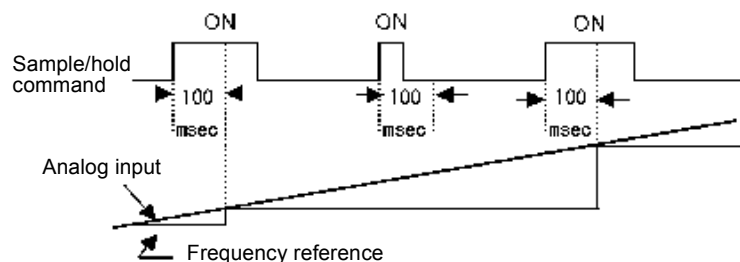

Fig 6.52 Sample/hold Analog Frequency

■ Precautions

When setting and executing sample and hold for analog frequency references, observe the following precautions.

Setting Precautions

When using sample/hold of analog frequency reference, you cannot use the following commands at the same time. If these commands are used at the same time, operation error OPE03 (invalid multi-function input selection) will occur.

- Acceleration/Deceleration Ramp Hold command
- UP/DOWN command
- Trim Control Increase/Decrease command

Application Precautions

- When performing sample/hold of analog frequency references, be sure to store references of 100 ms minimum. If the reference time is less than 100 ms, the frequency reference will not be held.
- The analog frequency reference that is held will be deleted when the power supply is turned OFF.

◆ Switching Operations between a Communications Option Card and Control Circuit Terminals

You can switch reference input between the Communications Option Card and the control circuit terminals. Set one of the constants H1-01 to H1-10 (multi-function contact input terminal S3 to S12 function selection) to 2 (Option/Inverter selection) to enable switching reference input using the terminal ON/OFF status when the Inverter is stopped.

■ Setting Precautions

To switch command inputs between the Communications Option Card and the control circuit terminals, set the following constants.

- Set b1-01 (Reference Selection) to 1 (Control circuit terminal [analog input])
- Set b1-02 (Operation Method Selection) to 1 (Control circuit terminal (sequence inputs))
- Set one of the constants H1-01 to H1-10 (multi-function contact input terminal S3 to S12 function selection) to 2 (Option/Inverter selection).

Terminal Status	Frequency Reference and Run Command Selection
OFF	Inverter (Can be operated from frequency reference or control circuit terminal from analog input terminal.)
ON	Communications Option Card (Frequency reference and run command are enabled from communications Option Card.)

◆ Jog Frequency Operation without Forward and Reverse Commands (FJOG/RJOG)

The FJOG/RJOG command functions operate the Inverter using jog frequencies by using the terminal ON/OFF operation. When using the FJOG/RJOG commands, there is no need to input the run command.

To use this function, set one of the constants H1-01 to H1-10 (multi-function contact input terminal S3 to S12 function selection) to 12 (FJOG command) or 13 (RJOG command).

■ Related Constants

Constant Number	Name	Description	Setting Range	Factory Setting	Change during Operation	Control Methods				
	Display					V/f	V/f with PG	Open Loop Vector 1	Flux Vector	Open Loop Vector 2
d1-17	Jog frequency reference	The frequency reference when the jog frequency reference selection, FJOG command, or RJOG command is ON.	0 to 400.00	6.00 Hz	Yes	Q	Q	Q	Q	Q
	Jog Reference									

Multi-Function Contact Inputs (H1-01 to H1-10)

Setting Value	Function	Control Methods				
		V/f	V/f with PG	Open Loop Vector 1	Flux Vector	Open Loop Vector 2
12	FJOG command (ON: Forward run at jog frequency d1-17)	Yes	Yes	Yes	Yes	Yes
13	RJOG command (ON: Reverse run at jog frequency d1-17)	Yes	Yes	Yes	Yes	Yes

■ Application Precautions

- Jog frequencies using FJOG and RJOG commands are given priority over other frequency references.
- When both FJOG command and RJOG commands are ON for 500 ms or longer at the same time, the Inverter stops according to the setting in b1-03 (stopping method selection).

◆ Stopping the Inverter by Notifying Programming Device Errors to the Inverter (External Fault Function)

The external fault function performs the error contact output, and stops the Inverter operation if the Inverter peripheral devices break down or an error occurs. The digital operator will display EFx (External fault [input terminal Sx]). The x in EFx shows the terminal number of the terminal that input the external fault signal. For example, if an external fault signal is input to terminal S3, EF3 will be displayed.

To use the external fault function, set one of the values 20 to 2F in one of the constants H1-01 to H1-10 (multi-function contact input terminal S3 to S12 function selection).

Select the value to be set in H1-01 to H1-10 from a combination of any of the following three conditions.

- Signal input level from peripheral devices
- External fault detection method
- Operation during external fault detection

The following table shows the relationship between the combinations of conditions and the set value in H1-□□.

Set Value	Input Level (See Note 1.)		Error Detection Method (See Note 2.)		Operation During Error Detection			
	NO Contact	NC Contact	Constant Detection	Detection During Operation	Decelerate to Stop (Error)	Coast to Stop (Error)	Emergency Stop (Error)	Continue Operation (Warning)
20	Yes		Yes		Yes			
21		Yes	Yes		Yes			
22	Yes			Yes	Yes			
23		Yes		Yes	Yes			
24	Yes		Yes			Yes		
25		Yes	Yes			Yes		
26	Yes			Yes		Yes		
27		Yes		Yes		Yes		
28	Yes		Yes				Yes	
29		Yes	Yes				Yes	
2A	Yes			Yes			Yes	
2B		Yes		Yes			Yes	
2C	Yes		Yes					Yes
2D		Yes	Yes					Yes
2E	Yes			Yes				Yes
2F		Yes		Yes				Yes

Note 1. Set the input level to detect errors using either signal ON or signal OFF. (NO contact: External fault when ON; NC contact: External fault when OFF).

- Note 2. Set the detection method to detect errors using either constant detection or detection during operation.
 Constant detection: Detects while power is supplied to the Inverter.
 Detection during operation: Detects only during Inverter operation.

Monitor Constants

This section explains the analog monitor and pulse monitor constants.

◆ Using the Analog Monitor Constants

This section explains the analog monitor constants.

■ Related Constants

Constant Number	Name	Description	Setting Range	Factory Setting	Change during Operation	Control Methods				
	Display					V/f	V/f with PG	Open Loop Vector 1	Flux Vector	Open Loop Vector 2
H4-01	Monitor selection (terminal FM)	Sets the number of the monitor item to be output (U1-□□) from terminal FM.	1 to 45	2	No	A	A	A	A	A
	Terminal FM Sel	4, 10 to 14, 25, 28, 34, 39, 40 cannot be set. 29 to 31 and 41 are not used.								
H4-02	Gain (terminal FM)	Sets the multi-function analog output 1 voltage level gain.	0.00 to 2.50 (0 to 1000.0)	1.00 (100%)	Yes	Q	Q	Q	Q	Q
	Terminal FM Gain	Sets whether the monitor item output will be output in multiples of 10 V. The maximum output from the terminal is 10 V. A meter calibration function is available.								
H4-03	Bias (terminal FM)	Sets the multi-function analog output 1 voltage level bias.	-10.0 to +10.0 (-100.0 to 100.0)	0.0% (0.0%)	Yes	A	A	A	A	A
	Terminal FM Bias	Sets output characteristic up/down parallel movement as a percentage of 10 V. The maximum output from the terminal is 10 V. A meter calibration function is available.								
H4-04	Monitor selection (terminal AM)	Sets the number of the monitor item to be output (U1-□□) from terminal AM.	1 to 45	3	No	A	A	A	A	A
	Terminal AM Sel	4, 10 to 14, 25, 28, 34, 39, 40 cannot be set. 29 to 31 and 41 are not used.								
H4-05	Gain (terminal AM)	Set the voltage level gain for multi-function analog output 2.	0.00 to 2.50 (0 to 1000.0)	0.50 (200%)	Yes	Q	Q	Q	Q	Q
	Terminal AM Gain	Set the number of multiples of 10 V to be output as the 100% output for the monitor items. The maximum output from the terminal is 10 V. A meter calibration function is available.								
H4-06	Bias (terminal AM)	Sets the multi-function analog output 2 voltage level bias.	-10.0 to +10.0 (0 to 1000.0)	0.0% (0.0%)	Yes	A	A	A	A	A
	Terminal AM Bias	Sets output characteristic up/down parallel movement as a percentage of 10 V. The maximum output from the terminal is 10 V. A meter calibration function is available.								

Constant Number	Name	Description	Setting Range	Factory Setting	Change during Operation	Control Methods				
	Display					V/f	V/f with PG	Open Loop Vector 1	Flux Vector	Open Loop Vector 2
H4-07	Analog output 1 signal level selection	Sets the signal output level for multi-function output 1 (terminal FM) 0: 0 to +10 V output 1: 0 to ±10 V output	0 or 1	0	No	A	A	A	A	A
	AO Level Select1									
F4-01	Channel 1 monitor selection	Effective when the Analog Monitor Card is used. Monitor selection: Set the number of the monitor item to be output. (U1-□□)	1 to 45	2	No	A	A	A	A	A
	AO Ch1 Select									
F4-02	Channel 1 gain	Gain: Set the multiple of 10 V for outputting monitor items. 4, 10 to 14, 25, 28, 34, 39, 40 cannot be set. 29 to 31 and 41 are not used.	0.00 to 2.50	1.00	Yes	A	A	A	A	A
	AO Ch1 Gain									
F4-03	Channel 2 monitor selection	When the AO-12 Analog Monitor Card is used, outputs of ± 10 V are possible. To output ± 10 V, set F4-07 or F4-08 to 1. When the AO-08 Analog Monitor Card is used, only outputs of 0 to +10 V are possible. A meter calibration function is available.	1 to 45	3	No	A	A	A	A	A
	AO Ch2 Select									
F4-04	Channel 2 gain	A meter calibration function is available.	0.00 to 2.50	0.50	Yes	A	A	A	A	A
	AO Ch2 Gain									
F4-05	Channel 1 output monitor bias	Sets the channel 1 item bias to 100%/10 V when the analog monitor card is used.	-10.0 to 10.0	0.0	Yes	A	A	A	A	A
	AO Ch1 Bias									
F4-06	Channel 2 output monitor bias	Sets the channel 2 item bias to 100%/10 V when the analog monitor card is used.	-10.0 to 10.0	0.0	Yes	A	A	A	A	A
	AO Ch2 Bias									
F4-07	Analog output signal level for channel 1	0: 0 to 10 V 1: -10 to +10 V	0 or 1	0	No	A	A	A	A	A
	AO Opt Level Sel									
F4-08	Analog output signal level for channel 2	0: 0 to 10 V 1: -10 to +10 V	0 or 1	0	No	A	A	A	A	A
	AO Opt Level Sel									

■ Selecting Analog Monitor Items

The digital operator monitor items (U1-□□ [status monitor]) are output from multi-function analog output terminals FM-AC and AM-AC. Refer to *Chapter 5 User Constants*, and set the values for the □□ part of U1-□□ (status monitor).

Alternatively, you can output monitor items (U1-□□ [status monitor]) from analog output option terminal channels 1 and 2 on analog monitor cards AO-08 and AO-12. Refer to the table of constants, and set the values.

■ Adjusting the Analog Monitor Items

Adjust the output voltage for multi-function analog output terminals FM-AC and AM-AC using the gain and bias in H4-02, H4-03, H4-05, and H4-06. Also, adjust the output voltage for output channels 1 and 2 of Analog Output Option Cards AO-08 and AO-12 using the gain and bias in F4-02, F4-04, and F4-06.

Adjusting the Meter

Display the data setting display for the gain and bias constants corresponding to the output channel of the Inverter Unit and the AO Option Card while the Inverter is stopped to output the following voltages to the analog monitor terminal, to enable meter adjusting while the Inverter is stopped.

$$10 \text{ V}/100\% \text{ monitor output} \times \text{output gain} + \text{output bias}$$

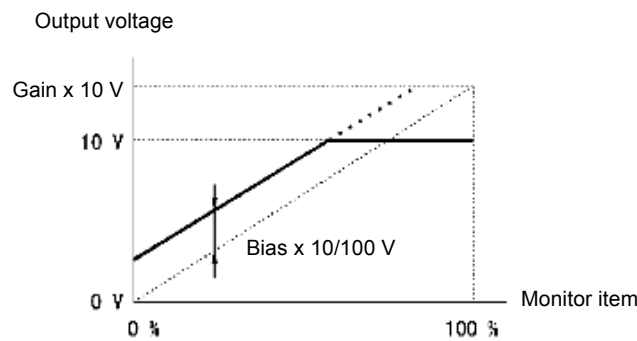

Fig 6.53 Monitor Output Adjustment

■ Switching Analog Monitor Signal Levels

Monitor items corresponding to 0 to ± 10 V output 0 to 10 V signals when the monitor value is positive (+), and 0 to -10 V signals when the monitor value is negative (-). For monitor items corresponding to 0 to ± 10 V, refer to *Chapter 5 User Constants*.



INFO

You can select the signal levels separately for multi-function analog output terminals and analog output option terminals.

◆ Using Pulse Train Monitor Contents

This section explains pulse monitor constants.

■ Related Constants

Constant Number	Name	Description	Setting Range	Factory Setting	Change during Operation	Control Methods				
	Display					V/f	V/f with PG	Open Loop Vector 1	Flux Vector	Open Loop Vector 2
H6-06	Pulse train monitor selection	Select the pulse train monitor output items (value of the □□ part of U1-□□). There are two types of monitor items: Speed-related items and PID-related items.	1, 2, 5, 20, 24, 36	2	Yes	A	A	A	A	A
	Pulse Output Sel									
H6-07	Pulse train monitor scaling	Set the number of pulses output when speed is 100% in hertz. Set H6-06 to 2, and H6-07 to 0, to make the pulse train monitor output synchronously to the output frequency.	0 to 32000	1440 Hz	Yes	A	A	A	A	A
	PO Scaling									

■ Selecting Pulse Monitor Items

Output digital operator monitor items (U1-□□ [status monitor]) from pulse monitor terminal MP-SC. Refer to *Chapter 5 User Constants*, and set the □□ part of U1-□□ (Status monitor). The possible monitor selections are limited as follows: U1-01, 02, 05, 20, 24, 36.

■ Adjusting the Pulse Monitor Items

Adjust the pulse frequency output from pulse monitor terminal MP-SC. Set the pulse frequency output when 100% frequency is output to H6-07.

Set H6-06 to 2, and H6-07 to 0, to output the frequency synchronous with the Inverter's U-phase output.

■ Application Precautions

When using a pulse monitor constant, connect a peripheral device according to the following load conditions. If the load conditions are different, there is a risk of characteristic insufficiency or damage to the machinery.

Using a Sourcing Output

Output Voltage (Isolated) VRL (V)	Load Impedance (kΩ)
+5 V min.	1.5 kΩ min.
+8 V min.	3.5 kΩ min.
+10 V min.	10 kΩ min.

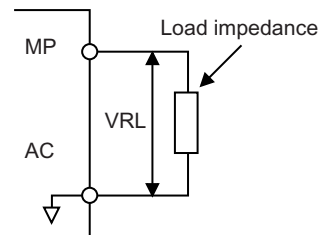

Using a Sinking Input

External Power Supply (V)	12 VDC \pm 10%, 15 VDC \pm 10%
Sink Current (mA)	16 mA Max

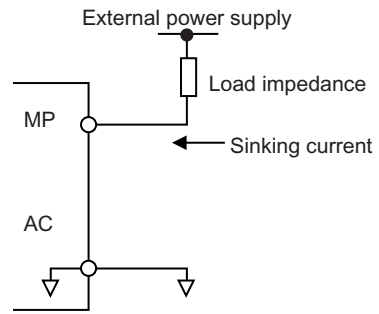

Individual Functions

This section explains the individual functions used in special applications.

◆ Using MEMOBUS Communications

You can perform serial communications with MEMOCON-series Programmable Controllers (PLCs) or similar devices using the MEMOBUS protocol.

■ MEMOBUS Communications Configuration

MEMOBUS communications are configured using 1 master (PLC) and a maximum of 31 slaves. Serial communications between master and slave are normally started by the master, and the slave responds.

The master performs signal communications with one slave at a time. Consequently, you must set the address of each slave beforehand, so the master can perform signal communications using that address. Slaves receiving commands from the master perform the specified function, and send a response to the master.

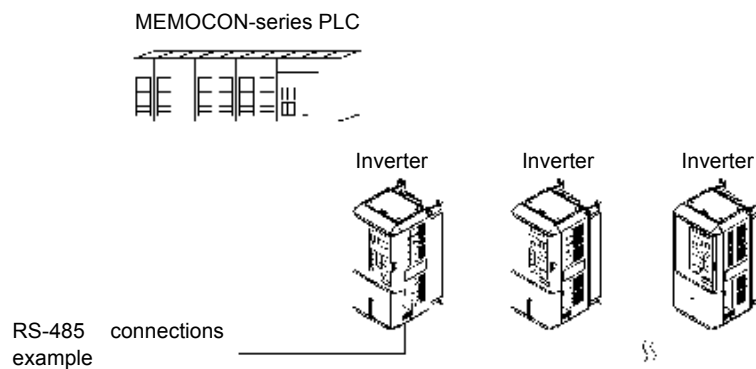

Fig 6.54 Example of Connections between PLC and Inverter

■ Communications Specifications

The MEMOBUS communications specifications are shown in the following table.

Item	Specifications
Interface	RS-422, RS-485
Communications Cycle	Asynchronous (Start-stop synchronization)
Communications Parameters	Baud rate: Select from 1,200, 2,400, 4,800, 9,600, and 19,200 bps.
	Data length: 8 bits fixed
	Parity: Select from even, odd, or none.
	Stop bits: 1 bit fixed
Communications Protocol	MEMOBUS (RTU mode only)
Number of Connectable Units	31 units max. (when using RS-485)

■ Communications Connection Terminal

MEMOBUS communications use the following terminals: S+, S-, R+, and R-. Set the terminating resistance by turning ON pin 1 of switch S1 for the last Inverter only, as seen from the PLC.

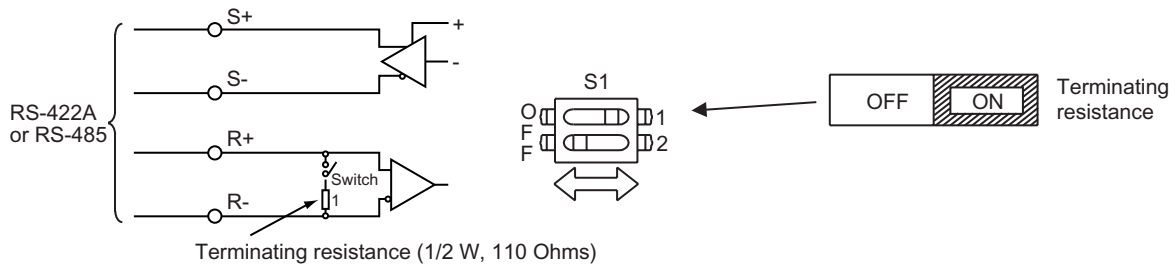
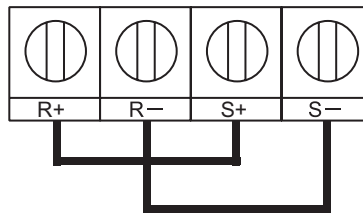

Fig 6.55 Communications Connection Terminal



IMPORTANT

1. Separate the communications cables from the main circuit cables and other wiring and power cables.
2. Use shielded cables for the communications cables, connect the shield cover to the Inverter earth terminal, and arrange the terminals so that the other end is not connected to prevent operating errors due to noise.
3. When using RS-485 communications, connect S+ to R+, and S- to R-, on the Inverter exterior.



■ Procedure for Communicating with the PLC

Use the following procedure to perform communications with the PLC.

1. Turn OFF the power supply turned and connect the communications cable between the PLC and the Inverter.
2. Turn ON the power supply.
3. Set the required communications constants (H5-01 to H5-07) using the Digital Operator.
4. Turn OFF the power supply, and check that the Digital Operator display has completely disappeared.
5. Turn ON the power supply once again.
6. Perform communications with the PLC.



INFO

Set the timer on the master to monitor response time from the slave. Set the master so that if the slave does not respond to the master within the set time, the same command message will be sent from the master again.

■ Related Constants

Constant Number	Name	Description	Setting Range	Factory Setting	Change during Operation	Control Methods				
	Display					V/f	V/f with PG	Open Loop Vector 1	Flux Vector	Open Loop Vector 2
b1-01	Reference selection	Set the frequency reference input method. 0: Digital Operator 1: Control circuit terminal (analog input) 2: MEMOBUS communications 3: Option Card 4: Pulse train input	0 to 4	1	No	Q	Q	Q	Q	Q
	Reference Source									
b1-02	Operation method selection	Set the run command input method. 0: Digital Operator 1: Control circuit terminal (sequence input) 2: MEMOBUS communications 3: Option Card	0 to 3	1	No	Q	Q	Q	Q	Q
	Run Source									
H5-01	Station address	Set the Inverter's node address.	0 to 20 [*]	1F	No	A	A	A	A	A
	Serial Comm Adr									
H5-02	Communication speed selection	Set the baud rate for 6CN MEMOBUS communications. 0: 1200 bps 1: 2400 bps 2: 4800 bps 3: 9600 bps 4: 19200 bps	0 to 4	3	No	A	A	A	A	A
	Serial Baud Rate									
H5-03	Communication parity selection	Set the parity for 6CN MEMOBUS communications. 0: No parity 1: Even parity 2: Odd parity	0 to 2	0	No	A	A	A	A	A
	Serial Com Sel									
H5-04	Stopping method after communication error	Set the stopping method for communications errors. 0: Deceleration to stop using deceleration time in C1-02 1: Coast to stop 2: Emergency stop using deceleration time in C1-09 3: Continue operation	0 to 3	3	No	A	A	A	A	A
	Serial Fault Sel									
H5-05	Communication error detection selection	Set whether or not a communications timeout is to be detected as a communications error. 0: Do not detect. 1: Detect	0 or 1	1	No	A	A	A	A	A
	Serial Flt Dtct									
H5-06	Send wait time	Set the time from the Inverter receiving data to when the Inverter starts to send.	5 to 65	5 ms	No	A	A	A	A	A
	Transmit WaitTIM									
H5-07	RTS control ON/OFF	Select to enable or disable RTS control. 0: Disabled (RTS is always ON) 1: Enabled (RTS turns ON only when sending)	0 or 1	1	No	A	A	A	A	A
	RTS Control Sel									

* Set H5-01 to 0 to disable Inverter responses to MEMOBUS communications.

MEMOBUS communications can perform the following operations regardless of the settings in b1-01 and b1-02.

- Monitoring operation status from the PLC
- Setting and reading constants
- Resetting errors
- Inputting multi-function commands

An OR operation is performed between the multi-function commands input from the PLC and commands input from multi-function contact input terminals S3 to S7.

■ Message Format

In MEMOBUS communications, the master sends commands to the slave, and the slave responds. The message format is configured for both sending and receiving as shown below, and the length of data packets is changed by the command (function) contents.

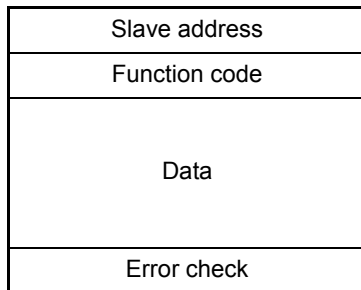

The space between messages must support the following.

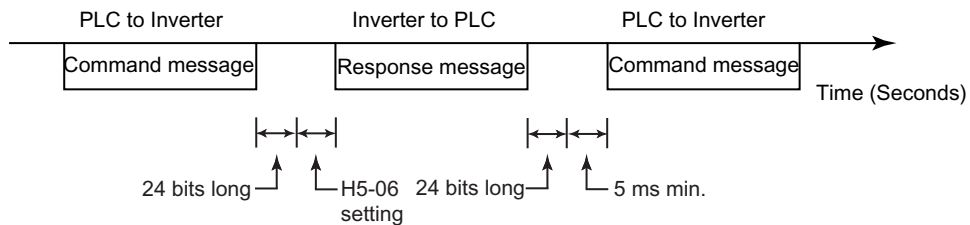

Fig 6.56 Message Spacing

Slave Address

Set the Inverter address from 0 to 32. If you set 0, commands from the master will be broadcast (i.e., the Inverter will not return responses).

Function Code

The function code specifies commands. There are three function codes, as shown below.

Function Code (Hexadecimal)	Function	Command Message		Response Message	
		Min. (Bytes)	Max. (Bytes)	Min. (Bytes)	Max. (Bytes)
03H	Read storage register contents	8	8	7	37
08H	Loopback test	8	8	8	8
10H	Write multiple storage registers	11	41	8	8

Data

Configure consecutive data by combining the storage register address (test code for a loopback address) and the data the register contains. The data length changes depending on the command details.

Error Check

Errors are detected during communications using CRC-16. Perform calculations using the following method.

1. The factory setting for CRC-16 communications is usually 0, but when using the MEMOBUS system, set the factory setting to 1 (i.e., set all 16 bits to 1).
2. Calculate CRC-16 using MSB as slave address LSB, and LSB as the MSB of the final data.
3. Also calculate CRC-16 for response messages from the slaves, and compare them to the CRC-16 in the response messages.

MEMOBUS Message Example

An example of MEMOBUS command/response messages is given below.

Reading Storage Register Contents

Read the contents of the storage register only for specified quantities whose addresses are consecutive, starting from a specified address. The contents of the storage register are separated into higher place 8 bits and lower place 8 bits, and comprise the data within response messages in address order.

The following table shows message examples when reading status signals, error details, data link status, and frequency references from the slave 2 Inverter.

Command Message			Response Message (During Normal Operation)			Response Message (During Error)		
Slave Address		02H	Slave Address		02H	Slave Address		02H
Function Code		03H	Function Code		03H	Function Code		83H
Start Address	Higher place	00H	Data quantity		08H	Error code		03H
	Lower place	20H	Lead storage register	Higher place	00H	CRC-16	Higher place	F1H
Quantity	Higher place	00H		Lower place	65H		Lower place	31H
	Lower place	04H	Next storage register	Higher place	00H			
CRC-16	Higher place	45H		Lower place	00H			
	Lower place	F0H	Next storage register	Higher place	00H			
				Lower place	00H			
			Next storage register	Higher place	01H			
				Lower place	F4H			
			CRC-16	Higher place	AFH			
				Lower place	82H			

Loopback Test

The loopback test returns command messages directly as response messages without changing the contents to check the communications between the master and slave. You can set user-defined test code and data values.

The following table shows a message example when performing a loopback test with the slave 1 Inverter.

Command Message			Response Message (During Normal Operation)			Response Message (During Error)		
Slave address		01H	Slave address		01H	Slave address		01H
Function code		08H	Function code		08H	Function code		89H
Test Code	Higher place	00H	Test Code	Higher place	00H	Error Code		01H
	Lower place	00H		Data	Lower place	00H	CRC-16	Higher place
Data	Higher place	A5H	Data		Higher place	A5H		CRC-16
	Lower place	37H		CRC-16	Lower place	37H		
CRC-16	Higher place	DAH	CRC-16		Higher place	DAH		
	Lower place	8DH		CRC-16	Lower place	8DH		

Writing to Multiple Storage Registers

Write the specified data to each specified storage register from the specified addresses. The written data must be in the following order in the command message: Higher place 8 bits, then lower place 8 bits, in storage register address order.

The following table shows an example of a message when forward operation has been set at a frequency reference of 60.0 Hz in the slave 1 Inverter by the PLC.

Command Message			Response Message (During Normal Operation)			Response Message (During Error)		
Slave Address		01H	Slave Address		01H	Slave Address		01H
Function Code		10H	Function Code		10H	Function Code		90H
Start Address	Higher place	00H	Start Address	Higher place	00H	Error code		02H
	Lower place	01H		Quantity	Lower place	01H	CRC-16	Higher place
Quantity	Higher place	00H	Quantity		Higher place	00H		CRC-16
	Lower place	02H		CRC-16	Lower place	02H		
No. of data		04H	CRC-16		Higher place	10H		
Lead data	Higher place	00H		CRC-16	Lower place	08H		
	Lower place	01H						
Next data	Higher place	02H						
	Lower place	58H						
CRC-16	Higher place	63H						
	Lower place	39H						



INFO

Set the number of data specified using command messages as quantity of specified messages x 2. Handle response messages in the same way.

■ Data Tables

The data tables are shown below. The types of data are as follows: Reference data, monitor data, and broadcast data.

Reference Data

The reference data table is shown below. You can both read and write reference data.

Register No.	Contents	
0000H	Not used	
0001H	Frequency reference	
	Bit 0	Run/stop command 1: Run 0: Stop
	Bit 1	Forward/reverse operation 1: Reverse 0: Forward
	Bit 2	External fault 1: Error (EFO)
	Bit 3	Fault reset 1: Reset command
	Bit 4	ComNet
	Bit 5	ComCtrl
	Bit 6	Multi-function input command 3
	Bit 7	Multi-function input command 4
	Bit 8	Multi-function input command 5
	Bit 9	Multi-function input command 6
	Bit A	Multi-function input command 7
	Bit B	Multi-function input command 8
	Bit C	Multi-function input command 9
	Bit D	Multi-function input command 10
	Bit E	Multi-function input command 11
Bit F	Multi-function input command 12	
0002H	Frequency reference (Set units using constant 01-03)	
0003H	Not used	
0004H	Torque reference	
0005H	Torque compensation	
0006H	PID target value	
0007H	Analog output 1 setting (-11 V/-1540 to 10 V/1540)	
0008H	Analog output 2 setting (-11 V/-1540 to 11 V/1540)	
0009H	Multi-function contact output setting	
	Bit 0	Contact output (terminal M1-M2) 1: ON 0: OFF
	Bit 1	Contact output (terminal M3-M4) 1: ON 0: OFF
	Bit 2	Contact output (terminal M5-M6) 1: ON 0: OFF
	Bit 3	PHC3(Contact P3-C3) 1: ON 0: OFF
	Bit 4	PHC4(Contact P4-C4) 1: ON 0: OFF
	Bit 5	Not used
	Bit 6	Set error contact (terminal MA-MC) output using bit 7. 1: ON 0: OFF
	Bit 7	Error contact (terminal MA-MC) 1: ON 0: OFF
	Bits 8 to F	Not used
000AH to 000EH	Not used	

Register No.	Contents	
000FH	Reference selection settings	
	Bit 0	Not used
	Bit 1	Use MEMOBUS 0006H PID target value
	Bits 2 to B	Not used
	C	Broadcast data terminal S5 input 1: Enabled 0: Disabled
	D	Broadcast data terminal S6 input 1: Enabled 0: Disabled
	E	Broadcast data terminal S7 input 1: Enabled 0: Disabled
	F	Broadcast data terminal S8 input 1: Enabled 0: Disabled

Note Write 0 to all unused bits. Also, do not write data to reserved registers.

Monitor Data

The following table shows the monitor data. Monitor data can only be read.

Register No.	Contents	
0020H	Inverter status	
	Bit 0	Operation 1: Operating 0: Stopped
	Bit 1	Reverse operation 1: Reverse operation 0: Forward operation
	Bit 2	Inverter startup complete 1: Completed 2: Not completed
	Bit 3	Error 1: Error
	Bit 4	Data setting error 1: Error
	Bit 5	Multi-function contact output 1 (terminal M1 - M2) 1: ON 0: OFF
	Bit 6	Multi-function contact output 2 (terminal M3 - M4) 1: ON 0: OFF
	Bit 7	Multi-function contact output 3 (terminal M5 - M6) 1: ON 0: OFF
	Bit 8	Multi-function PHC output 3 (terminal P3 - C3) 1: ON 0: OFF
	Bit 9	Multi-function PHC output 4 (terminal P4 - C4) 1: ON 0: OFF
Bits A and B	Not used	
0021H	Error details	
	Bit 0	Overcurrent (OC) Ground fault (GF)
	Bit 1	Main circuit overvoltage (OV)
	Bit 2	Inverter overload (OL2)
	Bit 3	Inverter overheat (OH1, OH2)
	Bit 4	Injection brake transistor resistance overheat (rr, rH)
	Bit 5	Fuse blown (PUF)
	Bit 6	PID feedback reference lost (FbL)
	Bit 7	External fault (EF, EFO)
	Bit 8	Hardware error (CPF)
	Bit 9	Motor overload (OL1), overtorque 1 (OL3) detected, or overtorque 2 (OL4) detected
	Bit A	PG broken wire detected (PGO), Overspeed (OS), Speed deviation (DEV)
	Bit B	Main circuit undervoltage (UV) detected
	Bit C	Main circuit undervoltage (UV1), control power supply error (UV2), inrush prevention circuit error (UV3), power loss
Bit D	SPO output phase open, SPI output phase open	
Bit E	MEMOBUS communications error (CE)	
Bit F	Operator disconnected (OPR)	
0022H	Data link status	
	Bit 0	Writing data
	Bit 1	Not used
	Bit 2	Not used
	Bit 3	Upper and lower limit errors
	Bit 4	Data integrity error
Bits 5 to F	Not used	
0023H	Frequency reference (U1-01)	
0024H	Output frequency (U1-02)	
0025H	Output voltage reference (U1-06)	
0026H	Output current (U1-03)	
0027H	Output power (U1-08)	
0028H	Torque reference (U1-09)	

Register No.	Contents	
0029H	Not used	
002AH	Not used	
002BH	Sequence input status	
	Bit 0	1: Control circuit terminal S1 ON
	Bit 1	1: Control circuit terminal S2 ON
	Bit 2	1: Control circuit terminal S3 ON
	Bit 3	1: Control circuit terminal S4 ON
	Bit 4	1: Control circuit terminal S5 ON
	Bit 5	1: Control circuit terminal S6 ON
	Bit 6	1: Control circuit terminal S7 ON
	Bit 7	1: Control circuit terminal S8 ON
	Bit 8	1: Control circuit terminal S9 ON
	Bit 9	1: Control circuit terminal S10 ON
	Bit A	1: Control circuit terminal S11 ON
	Bit B	1: Control circuit terminal S12 ON
	Bits C to F	Not used
002CH	Inverter status	
	Bit 0	Operation 1: Operating
	Bit 1	Zero speed 1: Zero speed
	Bit 2	Frequency matching 1: Matched
	Bit 3	User-defined speed matching 1: Matched
	Bit 4	Frequency detection 1
	Bit 5	Frequency detection 2
	Bit 6	Inverter startup completed 1: Startup completed
	Bit 7	Low voltage detection 1: Detected
	Bit 8	Baseblock 1: Inverter output baseblock
	Bit 9	Frequency reference mode 1: Not communications 0: Communications
	Bit A	Run command mode 1: Not communications 0: Communications
	Bit B	Overtorque detection 1: Detected
	Bit C	Frequency reference lost 1: Lost
	Bit D	Retrying error 1: Retrying
	Bit E	Error (including MEMOBUS communications time-out) 1: Error occurred
Bit F	MEMOBUS communications time-out 1: Timed out	
002DH	Multi-function contact output status	
	Bit 0	Multi-function contact output 1 (terminal M1 - M2) 1: ON 0: OFF
	Bit 1	Multi-function contact output 2 (terminal M3 - M4) 1: ON 0: OFF
	Bit 2	Multi-function contact output 3 (terminal M5 - M6) 1: ON 0: OFF
	Bit 3	Multi-function PHC output 3 (terminal P3 - C3) 1: ON 0: OFF
	Bit 4	Multi-function PHC output 4 (terminal P4 - C4) 1: ON 0: OFF
Bits 5 to F	Not used	
002EH - 0030H	Not used	
0031H	Main circuit DC voltage	
0032H	Torque monitor	
0033H	Output power (U1-08)	
0034H - 0037H	Not used	
0038H	PID feedback quantity (Input equivalent to 100%/Max. output frequency; 10/1%; without sign)	
0039H	PID input quantity ($\pm 100\%$ / \pm Max. output frequency; 10/1%; with sign)	
003AH	PID output quantity ($\pm 100\%$ / \pm Max. output frequency; 10/1%; with sign)	
003BH	CPU software number	
003CH	Flash software number	

Register No.	Contents	
003DH	Communications error details	
	Bit 0	CRC error
	Bit 1	Invalid data length
	Bit 2	Not used
	Bit 3	Parity error
	Bit 4	Overrun error
	Bit 5	Framing error
	Bit 6	Time-out
	Bits 7 to F	Not used
003EH	kVA setting	
003FH	Control method	

Note Communications error details are stored until a fault reset is input (you can also reset while the Unit is operating).

Broadcast Data

The following table shows the broadcast data. You can also write this data.

Register Address	Contents	
0001H	Operation signal	
	Bit 0	Run command 1: Operating 0: Stopped
	Bit 1	Reverse operation command 1: Reverse 0: Forward
	Bits 2 and 3	Not used
	Bit 4	External fault 1: Error (set using H1-01)
	Bit 5	Fault reset 1: Reset command (set using H1-02)
	Bits 6 to B	Not used
	Bit C	Multi-function contact input terminal S5 input
	Bit D	Multi-function contact input terminal S6 input
	Bit E	Multi-function contact input terminal S7 input
Bit F	Multi-function contact input terminal S8 input	
0002H	Frequency reference	30000/100%

Note Bit signals not defined in the broadcast operation signals use local node data signals continuously.

■ENTER Command

When writing constants to the Inverter from the PLC using MEMOBUS communications, the constants are temporarily stored in the constant data area in the Inverter. To enable these constants in the constant data area, use the ENTER command.

There are two types of ENTER commands: ENTER commands that enable constant data in RAM, and ENTER commands that write data to EEPROM (non-volatile memory) in the Inverter at the same time as enabling data in RAM.

The following table shows the ENTER command data. ENTER command data can only be written.

The ENTER command is enabled by writing 0 to register number 0900H or 0910H.

Register No.	Contents
0900H	Write constant data to EEPROM
0910H	Constant data is not written to EEPROM, but refreshed in RAM only.



INFO

The maximum number of times you can write to EEPROM using the Inverter is 100 thousand. Do not frequently execute ENTER commands (0900H) written to EEPROM. The ENTER command registers are write-only. Consequently, if reading these registers, the register address will become invalid (Error code: 02H).

■ Error Codes

The following table shows MEMOBUS communications error codes.

Error Code	Contents
01H	Function code error A function code other than 03H, 08H, or 10H has been set by the PLC.
02H	Invalid register number error <ul style="list-style-type: none"> The register address you are attempting to access is not recorded anywhere. With broadcast sending, a start address other than 0000H, 0001H, or 0002H has been set.
03H	Invalid quantity error <ul style="list-style-type: none"> The number of data packets being read or written is outside the range 1 to 16. In write mode, the number of data packets in the message is not No. of packets x 2.
21H	Data setting error <ul style="list-style-type: none"> A simple upper limit or lower limit error has occurred in the control data or when writing constants. When writing constants, the constant setting is invalid.
22H	Write mode error <ul style="list-style-type: none"> Attempting to write constants from the PLC during operation. Attempting to write via ENTER commands from the PLC during operation. Attempting to write constants other than A1-00 to A1-05, E1-03, or 02-04 when warning alarm CPF03 (defective EEPROM) has occurred. Attempting to write read-only data.
23H	Writing during main circuit undervoltage (UV) error <ul style="list-style-type: none"> Writing constants from the PLC during UV (main circuit undervoltage) alarm. Writing via ENTER commands from the PLC during UV (main circuit undervoltage) alarm.
24H	Writing error during constants processing Attempting to write constants from the PLC while processing constants in the Inverter.

■ Slave Not Responding

In the following cases, the slave will ignore the write function. If the slave address specified in the command message is 0, all slaves execute the write function, but do not return response messages to the master.

- When a communications error (overrun, framing, parity, or CRC-16) is detected in the command message.
- When the slave address in the command message and the slave address in the Inverter do not agree.
- When the data that configures the message and the data time length exceeds 24 bits.
- When the command message data length is invalid.

Application Precautions

Set a timer in the master to monitor response time from the slaves. Make the setting so that if no response is sent to the master from the slave within the set time, the same command message is sent again from the master.

■ Self-Diagnosis

The Inverter has a built-in function for self-diagnosing the operations of serial communications interface circuits. This function is called the self-diagnosis function. The self-diagnosis function connects the communications parts of the send and receive terminals, receives the data sent by the Inverter, and checks if communications are being performed normally.

Perform the self-diagnosis function using the following procedure.

1. Turn ON the power supply to the Inverter, and set 67 (communications test mode) in constant H1-05 (Terminal S7 Function Selection).
2. Turn OFF the power supply to the Inverter.
3. Perform wiring according to the following diagram while the power supply is turned OFF.
4. Turn ON the terminating resistance. (Turn ON pin 1 on DIP switch 1.)
5. Turn ON the power supply to the Inverter again.

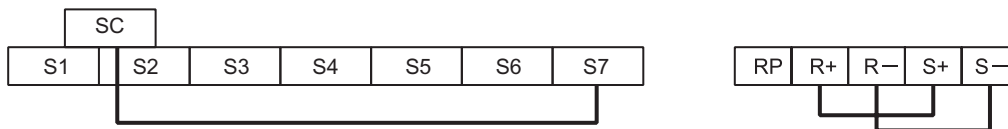

Fig 6.57 Details of Communications Terminals

“Pass” will be displayed if self-diagnosis is completed without an error occurring.

If an error occurs, a CE (MEMOBUS communications error) alarm will be displayed on the Digital Operator, the error contact output will be turned ON, and the Inverter operation ready signal will be turned OFF.

◆ Using the Timer Function

Multi-function contact input terminals S3 to S7 can be designated as timer function input terminals, and multi-function output terminals M1-M2, M3-M4, and M5-M6 can be designated as timer function output terminals. By setting the delay time, you can erase chattering from the sensors and switches.

- Set one of the constants H1-01 to H1-10 (multi-function contact input terminal S3 to S12) to 18 (timer function input).
- Set H2-01 to H2-03 (multi-function output terminals M1-M2, M3-M4, M5-M6, P3-C3, and P4-C4 function selection) to 12 (timer function output).

■ Related Constants

Constant Number	Name	Description	Setting Range	Factory Setting	Change during Operation	Control Methods				
	Display					V/f	V/f with PG	Open Loop Vector 1	Flux Vector	Open Loop Vector 2
b4-01	Timer function ON-delay time	Sets the timer function output ON-delay time (dead band) for the timer function input, in 1-second units. Enabled when a timer function is set in H1-□□ or H2-□□.	0.0 to 300.0	0.0 s	No	A	A	A	A	A
	Delay-ON Timer									
b4-02	Timer function OFF-delay time	Sets the timer function output OFF-delay time (dead band) for the timer function input, in 1-second units. Enabled when a timer function is set in H1-□□ or H2-□□.	0.0 to 300.0	0.0 s	No	A	A	A	A	A
	Delay-OFF Timer									

■ Setting Example

When the timer function input ON time is longer than the value set in b4-01, the timer output function is turned ON. When the timer function input OFF time is longer than the value set in b4-02, the timer output function is turned OFF. An example of timer function operation is given in the following diagram.

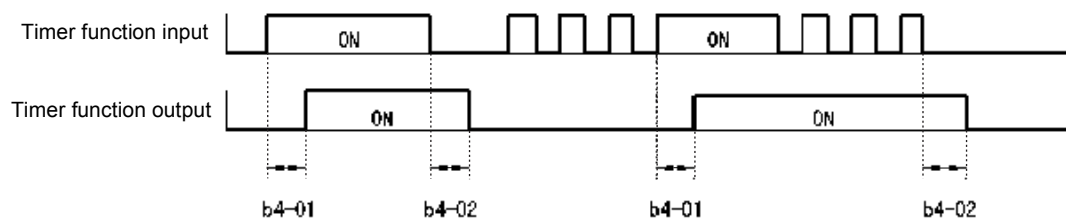

Fig 6.58 Timer Function Operation Example

◆ Using PID Control

PID control is a method of making the feedback value (detection value) match the set target value. By combining proportional control (P), integral control (I), and derivative control (D), you can even control targets (machinery) with play time.

The characteristics of the PID control operations are given below.

- P control Outputs the amount of operation proportional to the deviation. You cannot, however, set the deviation to zero using P control alone.
- I control Outputs the amount of operation that integrates the deviation. Used for matching feedback value to the target value. I control is not suited, however, to rapid variations.
- D control Outputs the amount of operation derived from the deviation. Can respond promptly to rapid variations.

■ PID Control Operation

To understand the differences between each PID control operation (P, I, and D, the variation in the amount of operation (output frequency) is as shown in the following diagram when the deviation (i.e., the difference between the target value and feedback value) is fixed.

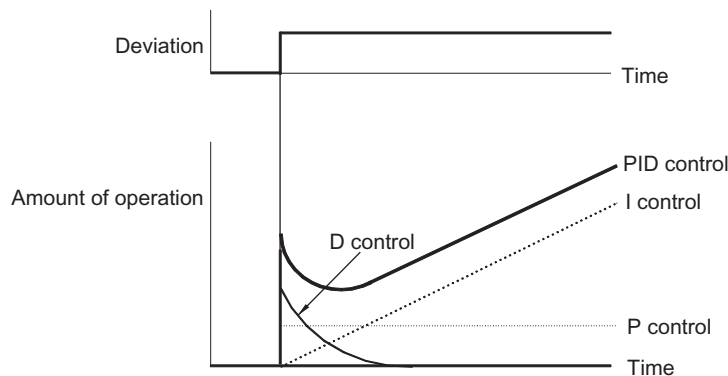

Fig 6.59 PID Control Operation

■ PID Control Applications

The following table shows examples of PID control applications using the Inverter.

Applica-tion	Control Details	Example of Sen-sor Used
Speed Con-trol	<ul style="list-style-type: none"> • Feeds back machinery speed information, and matches speed to the target value. • Inputs speed information from other machinery as the target value, and performs synchronous control using the actual speed feedback. 	Tachometer genera-tor
Pressure Control	Feeds back pressure information, and performs constant pressure control.	Pressure sensor
Flow Rate Control	Feeds back flow rate information, and controls the flow rate highly accurately.	Flow rate sensor
Tempera-ture Con-trol	Feeds back temperature information, and performs temperature adjustment control by rotating the fan.	<ul style="list-style-type: none"> • Thermocouple • Thermistor

■ Related Constants

Constant Number	Name	Description	Setting Range	Factory Setting	Change during Operation	Control Methods				
	Display					V/f	V/f with PG	Open Loop Vector 1	Flux Vector	Open Loop Vector 2
b5-01	PID control mode selection	0: Disabled 1: Enabled (Deviation is D-controlled.) 2: Enabled (Feedback value is D-controlled.) 3: PID control enabled (frequency reference + PID output, D control of deviation) 4: PID control enabled (frequency reference + PID output, D control of feedback value).	0 to 4	0	No	A	A	A	A	A
	PID Mode									
b5-02	Proportional gain (P)	Sets P-control proportional gain as a percentage. P-control is not performed when the setting is 0.00.	0.00 to 25.00	1.00	Yes	A	A	A	A	A
	PID Gain									
b5-03	Integral (I) time	Sets I-control integral time in 1-second units. I-control is not performed when the setting is 0.0.	0.0 to 360.0	1.0 s	Yes	A	A	A	A	A
	PID I Time									
b5-04	Integral (I) limit	Sets the I-control limit as a percentage of the maximum output frequency.	0.0 to 100.0	100.0%	Yes	A	A	A	A	A
	PID I Limit									
b5-05	Derivative (D) time	Sets D-control derivative time in 1-second units. D-control is not performed when the setting is 0.00.	0.00 to 10.00	0.00 s	Yes	A	A	A	A	A
	PID D Time									
b5-06	PID limit	Sets the limit after PID-control as a percentage of the maximum output frequency.	0.0 to 100.0	100.0%	Yes	A	A	A	A	A
	PID Limit									
b5-07	PID offset adjustment	Sets the offset after PID-control as a percentage of the maximum output frequency.	-100.0 to +100.0	0.0%	Yes	A	A	A	A	A
	PID Offset									
b5-08	PID primary delay time constant	Sets the time constant for low pass filter for PID-control outputs in 1-second units. Not usually necessary to set.	0.00 to 10.00	0.00 s	Yes	A	A	A	A	A
	PID Delay Time									
b5-09	PID output characteristics selection	Select forward/reverse for PID output. 0: PID output is forward. 1: PID output is reverse (highlights the output code)	0 or 1	0	No	A	A	A	A	A
	Output Level Sel									
b5-10	PID output gain	Sets output gain.	0.0 to 25.0	1.0	No	A	A	A	A	A
	Output Gain									
b5-11	PID reverse output selection	0: 0 limit when PID output is negative. 1: Reverses when PID output is negative. 0 limit when reverse prohibit is selected using b1-04.	0 or 1	0	No	A	A	A	A	A
	Output Rev Sel									

Constant Number	Name	Description	Setting Range	Factory Setting	Change during Operation	Control Methods				
	Display					V/f	V/f with PG	Open Loop Vector 1	Flux Vector	Open Loop Vector 2
b5-12	Selection of PID feedback command loss detection	0: No detection of loss of PID feedback. 1: Detection of loss of PID feedback. Operation continues during detection, with the malfunctioning contact not operating. 2: Detection of loss of PID feedback. Coasts to stop during detection, and fault contact operates.	0 to 2	0	No	A	A	A	A	A
	Fb los Det Sel									
b5-13	PID feedback command loss detection level	Sets the PID feedback loss detection level as a percent units, with the maximum output frequency at 100%.	0 to 100	0%	No	A	A	A	A	A
	Fb los Det Lvl									
b5-14	PID feedback command loss detection time	Sets the PID feedback loss detection level in s units.	0.0 to 25.5	1.0 s	No	A	A	A	A	A
	Fb los Det Time									
b5-15	PID sleep function operation level	Set the PID sleep function start level as a frequency.	0.0 to 400.0	0.0 Hz	No	A	A	A	A	A
	PID Sleep Level									
b5-16	PID sleep operation delay time	Set the delay time until the PID sleep function starts in seconds.	0.0 to 25.5	0.0 s	No	A	A	A	A	A
	PID Sleep Time									
b5-17	Accel/decel time for PID reference	Set the accel/decel time for PID reference in seconds.	0.0 to 25.5	0.0 s	No	A	A	A	A	A
	PID SFS Time									
H6-01	Pulse train input function selection	0: Frequency reference 1: PID feedback value 2: PID target value	0 to 2	0	No	A	A	A	A	A
	Pulse Input Sel									

Constant Number	Name	Description	Output Signal Level During Multi-Function Analog Output	Min. Unit	Control Methods				
	Display				V/f	V/f with PG	Open Loop Vector 1	Flux Vector	Open Loop Vector 2
U1-24	PID feedback value	Monitors the feedback value when PID control is used. The input for the max. frequency corresponds to 100%.	10 V: Max. frequency (0 to ± 10 V possible)	0.01 %	A	A	A	A	A
	PID Feedback								
U1-36	PID input volume	PID feedback volume Given as maximum frequency/100%	10 V: Max. frequency (0 to ± 10 V possible)	0.01 %	A	A	A	A	A
	PID Input								
U1-37	PID output volume	PID control output Given as maximum frequency/100%	10 V: Max. frequency (0 to ± 10 V possible)	0.01 %	A	A	A	A	A
	PID Output								

Constant Number	Name	Description	Output Signal Level During Multi-Function Analog Output	Min. Unit	Control Methods				
	Display				V/f	V/f with PG	Open Loop Vector 1	Flux Vector	Open Loop Vector 2
U1-38	PID command	PID command + PID command bias Given as maximum frequency/ 100%	10 V: Max. frequency	0.01 %	A	A	A	A	A
	PID Setpoint								

Multi-Function Contact Inputs (H1-01 to H1-10)

Setting Value	Function	Control Methods				
		V/f	V/f with PG	Open Loop Vector 1	Flux Vector	Open Loop Vector 2
19	PID control disable (ON: PID control disabled)	Yes	Yes	Yes	Yes	Yes
30	PID control integral reset (reset when reset command is input or when stopped during PID control)	Yes	Yes	Yes	Yes	Yes
31	PID control integral hold (ON: Hold)	Yes	Yes	Yes	Yes	Yes
34	PID soft starter	Yes	Yes	Yes	Yes	Yes
35	PID input characteristics switch	Yes	Yes	Yes	Yes	Yes

Multi-Function Analog Input (H3-05, H3-09)

Setting Value	Function	Contents (100%)	Control Methods				
			V/f	V/f with PG	Open Loop Vector 1	Flux Vector	Open Loop Vector 2
B	PID feedback	Maximum output frequency	Yes	Yes	Yes	Yes	Yes
C	PID target value	Maximum output frequency	Yes	Yes	Yes	Yes	Yes

■PID Control Methods

There are four PID control methods. Select the method by setting constant b5-01.

Set Value	Control Method
1	PID output becomes the Inverter output frequency, and D control is used in the difference between PID target value and feedback value.
2	PID output becomes the Inverter output frequency, and D control is used in the PID feedback value.
3	PID output is added as compensation value of the Inverter output frequency, and D control is used in the difference between PID target value and feedback value.
4	PID output is added as compensation value of the Inverter output frequency, and D control is used in the PID feedback value.

■PID Input Methods

Enable PID control using constant b5-01, and set the PID target value and PID feedback value.

PID Target Value Input Methods

Select the PID control target value input method according to the setting in b1-01 (Reference Selection). Normally, the frequency reference selected in b1-01 is the PID target value, but you can also set the PID target value as shown in the following table.

PID Target Input Method	Setting Conditions
Multi-Function Analog Terminal A2 Input	Set H3-05 or H3-09 to C (PID target value). Also, be sure to set H6-01 (pulse train input function selection) to 1 (PID feedback value).
MEMOBUS register 0006H	Set MEMOBUS bit 1 in register address 000FH to 1 to be able to use register number 0006H as the PID target value.
Pulse train input	Set H6-01 to 2 (PID target value).

PID Feedback Input Methods

Select one of the following PID control feedback input methods.

Input Method	Setting Conditions
Multi-function analog input	Set H3-09 (Multi-function Analog Input Terminal A2 Selection) or H3-05 (Multi-function Analog Input Terminal A3 Function Selection) to B (PID feedback).
Pulse train input	Set H6-01 to 1 (PID feedback).



INFO

Adjust PID target value and PID feedback value using the following items.

- Analog input: Adjust using the analog input terminal gain and bias.
- Pulse train input: Adjust using pulse train scaling, pulse train input gain, and pulse train input bias.

■PID Adjustment Methods

Use the following procedure to adjust PID while performing PID control and measuring the response waveform.

1. Set b5-01 (PID Control Mode Selection) to 1 or 2 (PID control enabled).
2. Increase b5-02 (Proportional Gain (P)) to within a range that does not vibrate.
3. Reduce b5-03 (Integral (I) time) to within a range that does not vibrate.
4. Increase b5-05 (Derivative (D) time) to within a range that does not vibrate.

■ PID Fine Adjustment Methods

This section explains the fine adjustment of PID after setting the PID control constants.

Suppressing Overshoot

If overshoot occurs, reduce derivative time (D), and increase integral time (I).

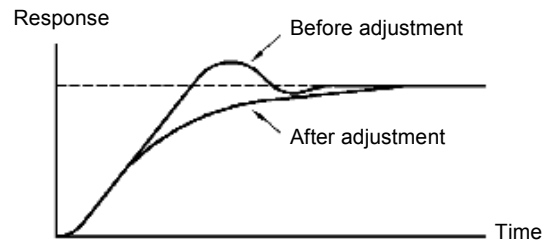

Set a Rapidly Stabilizing Control Condition

To rapidly stabilize the control even if overshoot occurs, reduce integral time (I), and lengthen derivative time (D).

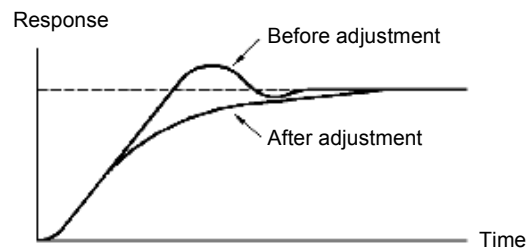

Suppressing Long-cycle Vibration

If vibration occurs with a longer cycle than the integral time (I) set value, the integral operation is too strong. Lengthen the integral time (I) to suppress the vibration.

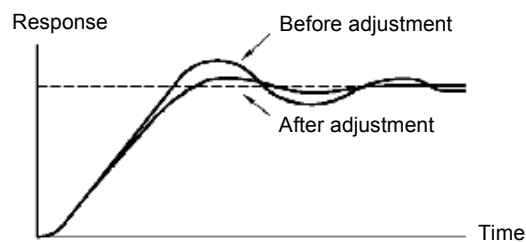

Suppressing Short Cycle Vibration

If vibration occurs when the vibration cycle is short, and the cycle is almost identical to the derivative time (D) set value, the differential operation is too strong. Shorten the derivative time (D) to suppress the vibration.

If vibration continues even when the derivative time (D) is set to 0.00 (D control disabled), reduce the proportional gain (P), or increase the PID primary delay time constant.

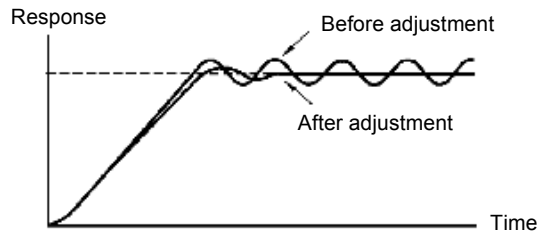

■ Setting Precautions

- In PID control, the b5-04 constant is used to prevent the calculated integral control value from exceeding a specified amount. When the load varies rapidly, Inverter response is delayed, and the machine may be damaged or the motor may stall. In this case, reduce the set value to speed up Inverter response.
- The b5-06 constant is used to prevent the arithmetic operation following the PID control calculation from exceeding a specified amount. Set taking the maximum output frequency to be 100%.
- The b5-07 constant is used to adjust PID control offset. Set in increments of 0.1%, taking the maximum output frequency to be 100%.
- Set the low pass filter time constant for the PID control output in b5-08. Enable this constant to prevent machinery resonance from occurring when machinery adhesive abrasion is great, or rigidity is poor. In this case, set the constant to be greater than the resonance frequency cycle. Increase this time constant to reduce Inverter responsiveness.
- Using b5-09, you can invert the PID output polarity. Consequently, if you increase the PID target value, you can apply this constant to applications to lower the Inverter output frequency.
- Using b5-10, you can apply gain to the PID control output. Enable this constant to adjust the amount of compensation if adding PID control output to the frequency reference as compensation.
- When PID control output is negative, you can use constant b5-11 to invert the Inverter. When b1-04 (Prohibition of Reverse Operation) is set to 1 (enabled), however, PID output limit is 0.
- With the Inverter, by setting an independent acceleration/deceleration time in constant b5-17, you can increase or decrease the PID target value using the acceleration/deceleration time. The acceleration/deceleration function (constant C1) used normally, however, is allocated after PID control, so depending on the settings, resonance with PID control and hunting in the machinery may occur. If this happens, reduce constant C1 until hunting does not occur, and maintain the acceleration/deceleration time using b5-17. Also, you can disable the set value in b5-17 from the external terminals during operation using multi-function input set value 34 (PID soft starter).

■ PID Control Block

The following diagram shows the PID control block in the Inverter.

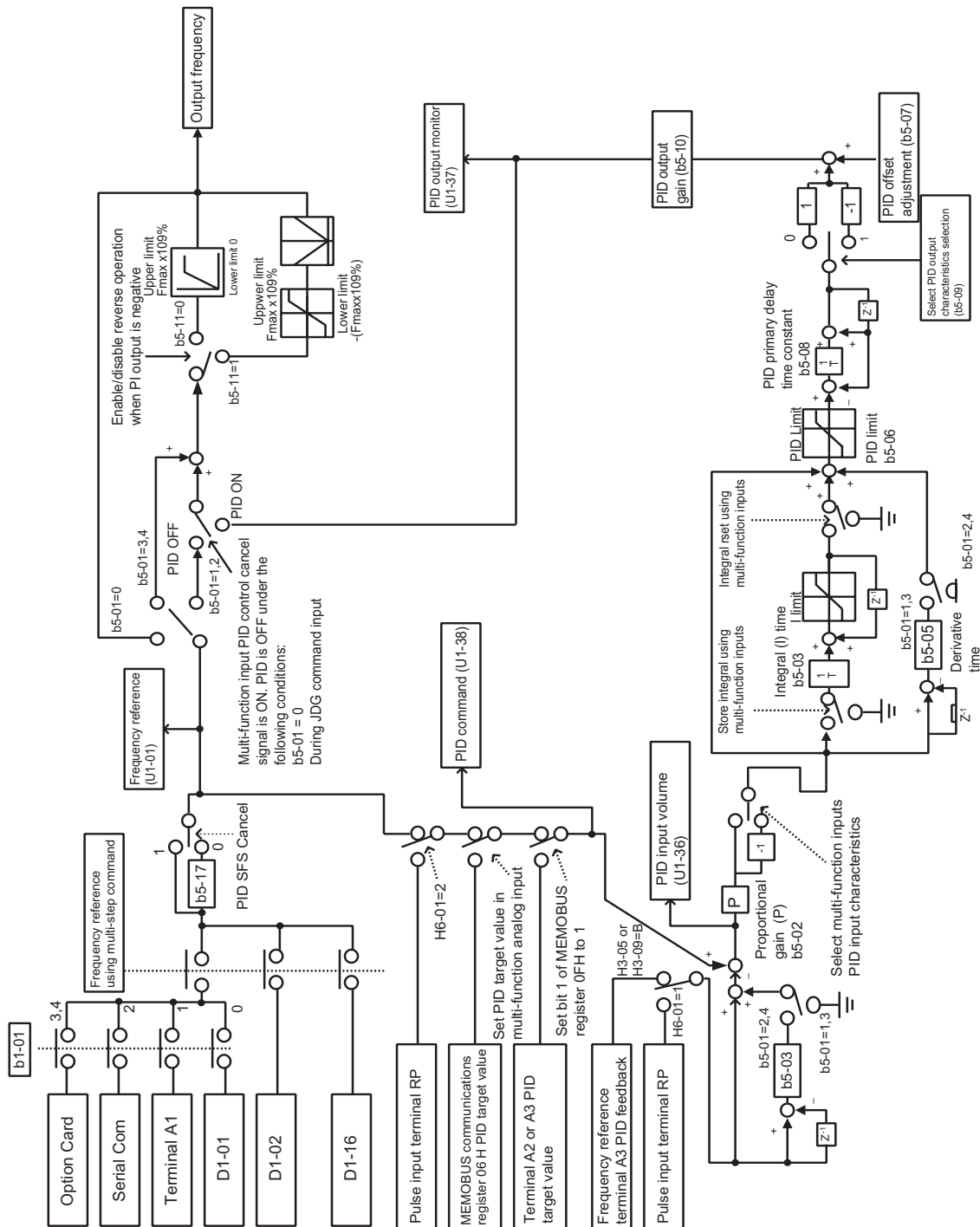

Fig 6.60 PID Control Block

■PID Feedback Loss Detection

When performing PID control, be sure to use the PID feedback loss detection function. If PID feedback is lost, the Inverter output frequency may accelerate to the maximum output frequency.

When setting b5-12 to 1 and the status of the PID feedback value detection level in b5-13 is insufficient and continues for the time set in b5-14, an FbL (PID feedback reference lost) alarm will be displayed on the Digital Operator and Inverter operation will continue.

When b5-12 is set to 2, an FbL (PID feedback reference lost) error alarm will be displayed on the Digital Operator, the error contact will operate, and Inverter operation will be stopped.

The time chart for PID feedback loss detection (set b5-12 to 2) is shown below.

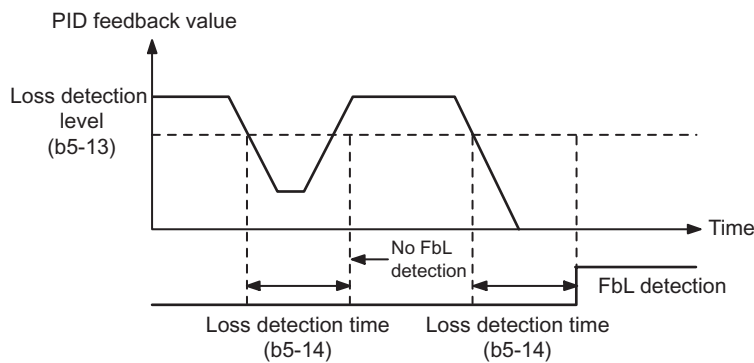

Fig 6.61 PID Feedback Loss Detection Time Chart

■PID Sleep

The PID sleep function stops the Inverter when the PID sleep function delay time continues while the PID control target value is at an insufficient level to operate the PID sleep function. When the PID sleep delay time continues and the PID control target value is above the PID sleep function operation level, Inverter operation will automatically resume.

When PID control is disabled, the PID sleep function is also disabled. When using the PID sleep function, select decelerate to stop or coast to stop as the stopping method.

The PID sleep time chart is shown below.

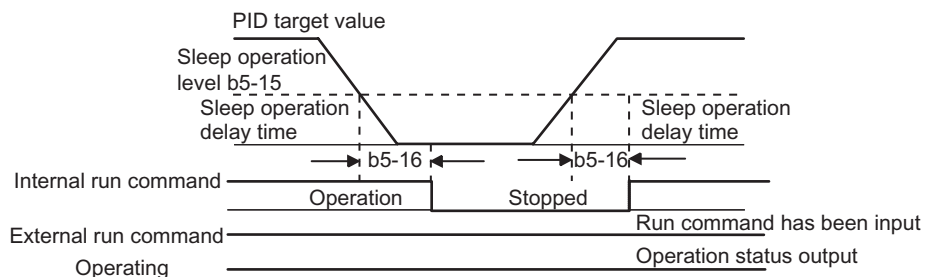

Fig 6.62 PID Sleep Time Chart

◆ Energy-saving

To perform energy saving, set b8-01 (Energy Saving Mode Selection) to 1. Energy-saving control can be performed using both V/f control and open-loop vector control. The constants to be adjusted are different for each. In V/f control, adjust b8-04 to b8-06, and in vector control, adjust b8-02 and b8-03.

■ Related Constants

Constant Number	Name	Description	Setting Range	Factory Setting	Change during Operation	Control Methods				
	Display					V/f	V/f with PG	Open Loop Vector 1	Flux Vector	Open Loop Vector 2
b8-01	Energy-saving mode selection	Select whether to enable or disable energy-saving control. 0: Disable 1: Enable	0 or 1	0	No	A	A	A	A	A
	Energy Save Sel									
b8-02	Energy-saving gain	Set the energy-saving gain with the open-loop vector control method.	0.0 to 10.0	0.7 *1	Yes	No	No	A	A	A
	Energy Save Gain									
b8-03	Energy-saving filter time constant	Set the energy-saving filter time constant with the open-loop vector control method.	0.00 to 10.0	0.50 s *2	Yes	No	No	A	A	A
	Energy Save F.T									
b8-04	Energy-saving coefficient	Set the maximum motor efficiency value. Set the motor rated capacity in E2-11, and adjust the value by 5% at a time until output power reaches a minimum value.	0.0 to 655.00	*3 *4	No	A	A	No	No	No
	Energy Save COEF									
b8-05	Power detection filter time constant	Set the time constant for output power detection.	0 to 2000	20 ms	No	A	A	No	No	No
	kW Filter Time									
b8-06	Search operation voltage limiter	Set the limit value of the voltage control range during search operation. Perform search operation to optimize operations using minute variations in voltage using energy-saving control. Set to 0 to disable the search operation. 100% is the motor base voltage.	0 to 100	0%	No	A	A	No	No	No
	Search V Limit									
E2-02	Motor rated slip	Sets the motor rated slip in Hz units. These set values will become the reference values for slip compensation. This constant is automatically set during autotuning.	0.00 to 20.00	2.90 Hz *4	No	A	A	A	A	A
	Motor Rated Slip									
E2-11	Motor rated output	Set the rated output of the motor in units of 0.01 kW. This constant is automatically set during autotuning.	0.00 to 650.00	0.40 *3	No	Q	Q	Q	Q	Q
	Mtr Rated Power									

* 1. The factory setting is 1.0 when using V/f control with PG.

* 2. The factory setting is 2.00 s when Inverter capacity is 55 kW min. The factory setting will change when the control method is changed. (Open-loop vector 1 factory settings are given.)

* 3. The same capacity as the Inverter will be set by initializing the constants.

* 4. The factory settings depend on the Inverter capacity.

■ Adjusting Energy-saving Control

The method of adjustment during energy-saving control operations differs depending on the control method. Refer to the following when making adjustments.

V/f Control

In V/f control method, the voltage for optimum motor efficiency is calculated and becomes the output voltage reference.

- b8-04 (Energy-saving Coefficient) is set at the factory for motor use applied to the Inverter. If the motor capacity differs from the motor applied to the Inverter, set the motor capacity in E2-11 (Motor Rated Output). Also, adjust the output voltage in steps of 5 until it reaches minimum. The larger the energy-saving coefficient, the greater the output voltage.
- To improve response when the load fluctuates, reduce the power detection filter time constant b8-05. If b8-05 is set too small, however, motor rotations when the load is light may become unstable.
- Motor efficiency varies due to temperature fluctuations and differences in motor characteristics. Consequently, control motor efficiency online to optimize efficiency by causing minute variations in voltage using the search operation. Constant b8-06 (Search Operation Voltage Limiter) controls the range that control the voltage using the search operation. For 200 V Class Inverters, set the range to 100%/200 V, and for 400 V Class Inverters, set the range to 100%/400 V. Set to 0 to disable the search operation.

Vector Control

In vector control method, control the slip frequency so that motor efficiency is maximized.

- Taking the motor rated slip for the base frequency as optimum slip, calculate the optimum slip for motor efficiency for each frequency. In vector control, be sure to perform autotuning, and set the motor rated slip.
- If the motor performs hunting when using energy-saving control in vector control, reduce the set value in b8-02 (Energy-saving Gain), or increase the set value in b8-03 (Energy-saving Filter Time Constant).

◆ Setting Motor Constants

In vector control method, the motor constants are set automatically using autotuning. If autotuning does not complete normally, set them manually.

■ Related Constants

Constant Number	Name	Description	Setting Range	Factory Setting	Change during Operation	Control Methods				
	Display					V/f	V/f with PG	Open Loop Vector 1	Flux Vector	Open Loop Vector 2
E2-01	Motor rated current	Sets the motor rated current in 1 A units.	0.32 to 6.40 *2	1.90 A *1	No	Q	Q	Q	Q	Q
	Motor Rated FLA	These set values will become the reference values for motor protection, torque limits and torque control. This constant is automatically set during autotuning.								
E2-02	Motor rated slip	Sets the motor rated slip in Hz units.	0.00 to 20.00	2.90 Hz *1	No	A	A	A	A	A
	Motor Rated Slip	These set values will become the reference values for slip compensation. This constant is automatically set during autotuning.								
E2-03	Motor no-load current	Sets the motor no-load current in 1 A units.	0.00 to 1.89 *3	1.20 A *1	No	A	A	A	A	A
	No-Load Current	This constant is automatically set during autotuning.								
E2-04	Number of motor poles	Sets the number of motor poles. This constant is automatically set during autotuning.	2 to 48	4 poles	No	No	Q	No	Q	Q
	Number of Poles									
E2-05	Motor line-to-line resistance	Sets the motor phase-to-phase resistance in Ω units.	0.000 to 65.000	9.842 Ω *1	No	A	A	A	A	A
	Term Resistance	This constant is automatically set during autotuning.								
E2-06	Motor leak inductance	Sets the voltage drop due to motor leakage inductance as a percentage of the motor rated voltage.	0.0 to 40.0	18.2% *1	No	No	No	A	A	A
	Leak Inductance	This constant is automatically set during autotuning.								
E2-07	Motor iron saturation coefficient 1	Sets the motor iron saturation coefficient at 50% of magnetic flux.	0.00 to 0.50	0.50	No	No	No	A	A	A
	Saturation Comp1	This constant is automatically set during autotuning.								
E2-08	Motor iron saturation coefficient 2	Sets the motor iron saturation coefficient at 75% of magnetic flux.	0.00 to 0.75	0.75	No	No	No	A	A	A
	Saturation Comp2	This constant is automatically set during autotuning.								
E2-10	Motor iron loss for torque compensation	Sets motor iron loss in W units.	0 to 65535	14 W *1	No	A	A	No	No	No
	Tcomp Iron Loss									

* 1. The factory settings depend on Inverter capacity (the values shown are for a 200 V Class Inverter for 0.4 kW).

* 2. The setting range is 10% to 200% of the Inverter rated output current (the values shown are for a 200 V Class Inverter for 0.4 kW).

* 3. The setting range depends on Inverter capacity (the values shown are for a 200 V Class Inverter for 0.4 kW).

■ Manual Motor Constant Setting Methods

The motor constants settings methods are given below. Make (enter) settings referring to the motor test report.

Motor Rated Voltage Setting

Set E2-01 to the rated current on the motor nameplate.

Motor Rated Slip Setting

Set E2-02 to the motor rated slip calculated from the number of rated rotations on the motor nameplate.

Amount of motor rated slip = Motor rated frequency (Hz) - No. of rated rotations (min^{-1}) x No. of motor poles/120.

Motor No-Load Current Setting

Set E2-03 to the motor no-load current using the rated voltage and rated frequency. The motor no-load current is not normally written on the motor nameplate. Consult the motor manufacturer.

Factory setting is the no-load current value for a standard Yaskawa 4-pole motor.

Number of Motor Poles Setting

E2-04 is displayed only when V/f control method with PG is selected. Set the number of motor poles (number of poles) as written on the motor nameplate.

Motor Line-to-Line Resistance Setting

E2-05 is set automatically when performing motor line-to-line resistance autotuning. When you cannot perform tuning, consult the motor manufacturer for the line-to-line resistance value. Calculate the resistance from the line-to-line resistance value in the motor test report using the following formula, and then make the setting accordingly.

- E-type isolation: [Line-to line resistance (Ω) at 75°C of test report] \times 0.92 (Ω)
- B-type isolation: [Line-to line resistance (Ω) at 75°C of test report] \times 0.92 (Ω)
- F-type isolation: [Line-to line resistance (Ω) at 115°C of test report] \times 0.87 (Ω)

Motor Leak Inductance Setting

Set the amount of voltage drop due to motor leak inductance in E2-06 using the percentage over the motor rated voltage. Make this setting when the high-speed motor inductance is small. If the inductance is not written on the motor nameplate, consult the motor manufacturer.

Motor Iron Saturation Coefficients 1 and 2 Settings

E2-07 and E2-08 are set automatically using autotuning.

Motor Iron Loss for Torque Compensation Setting

E2-10 is displayed only when in V/f control method. To increase the torque compensation accuracy when in V/f control method, set the motor iron loss in Watts.

Motor Mechanical Loss

When using flux vector control, adjust mechanical loss in the following cases. (There is normally no reason to make this adjustment.) The mechanical loss setting is used to compensate the torque.

- There is excessive torque loss from the motor bearings.
- There is excessive torque loss from a fan, pump, etc.

◆ Setting the V/f Pattern

In V/f control method, you can set the Inverter input voltage and the V/f pattern as the need arises.

■ Related Constants

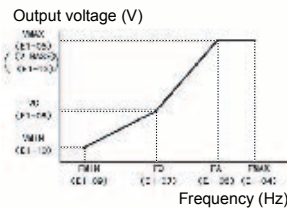
Constant Number	Name	Description	Setting Range	Factory Setting	Change during Operation	Control Methods					
	Display					V/f	V/f with PG	Open Loop Vector 1	Flux Vector	Open Loop Vector 2	
E1-01	Input voltage setting	Set the Inverter input voltage in 1 volt. This setting is used as a reference value in protection functions.	155 to 255 *1	200 V *1	No	Q	Q	Q	Q	Q	
	Input Voltage										
E1-03	V/f pattern selection	0 to E: Select from the 15 preset patterns. F: Custom user-set patterns (Applicable for settings E1-04 to E1-10.)	0 to F	F	No	Q	Q	No	No	No	
	V/F Selection										
E1-04	Max. output frequency	 <p>Output voltage (V)</p> <p>Frequency (Hz)</p> <p>To set V/f characteristics in a straight line, set the same values for E1-07 and E1-09. In this case, the setting for E1-08 will be disregarded. Always ensure that the four frequencies are set in the following manner: E1-04 (FMAX) ≥ E1-06 (FA) > E1-07 (FB) ≥ E1-09 (FMIN)</p>	40.0 to 400.0*5	60.0 Hz *2	No	Q	Q	Q	Q	Q	
	Max Frequency										
E1-05	Max. voltage		0.0 to 255.0 *1	200.0 V *1*2	No	Q	Q	Q	Q	Q	Q
	Max Voltage										
E1-06	Base frequency		0.0 to 400.0*5	60.0 Hz *2	No	Q	Q	Q	Q	Q	Q
	Base Frequency										
E1-07	Mid. output frequency		0.0 to 400.0	3.0 Hz *2	No	A	A	A	No	No	No
	Mid Frequency A										
E1-08	Mid. output frequency voltage		0.0 to 255.0*1	11.0 V *1*2	No	A	A	A	No	No	No
	Mid Voltage A										
E1-09	Min. output frequency	0.0 to 400.0*5	0.5 Hz *2	No	Q	Q	Q	A	Q	Q	
	Min Frequency										
E1-10	Min. output frequency voltage	0.0 to 255.0 *1	2.0 V *1*2	No	A	A	A	No	No	No	
	Min Voltage										

Constant Number	Name	Description	Setting Range	Factory Setting	Change during Operation	Control Methods				
	Display					V/f	V/f with PG	Open Loop Vector 1	Flux Vector	Open Loop Vector 2
E1-11	Mid. output frequency 2	Set only to fine-adjust V/f for the output range. Normally, this setting is not required.	0.0 to 400.0* ⁵	0.0 Hz* ³	No	A	A	A	A	A
	Mid Frequency B									
E1-12	Mid. output frequency voltage 2		0.0 to 255.0* ¹	0.0 V* ³	No	A	A	A	A	A
	Mid Voltage B									
E1-13	Base voltage		0.0 to 255.0* ¹	0.0 V* ⁴	No	A	A	Q	Q	Q
	Base Voltage									

- * 1. These are values for a 200 V Class Inverter. Values for a 400 V Class Inverter are double.
- * 2. The factory setting will change when the control method is changed. (Open-loop vector control factory settings are given.)
- * 3. The contents of constants E1-11 and E1-12 are ignored when set to 0.00.
- * 4. E1-13 is set to the same value as E1-05 by autotuning.
- * 5. The setting range is 0 to 66.0 for open-loop vector control 2.

■ Setting Inverter Input Voltage

Set the Inverter input voltage correctly in E1-01 to match the power supply voltage. This set value will be the standard value for the protection function and similar functions.

■ Setting V/f Pattern

Set the V/f pattern in E1-03 when using V/f control (with or without a PG). There are two methods of setting the V/f pattern: Select one of the 15 pattern types (set value: 0 to E) that have been set beforehand, or set a user-defined V/f pattern (set value: F).

The factory setting for E1-03 is F. The contents of E1-03 when factory-set to F are the same as when E1-03 is set to 1.

To select one of the existing patterns, refer to the following table.

Characteristic	Application	Set Value	Specifications
Constant Torque Characteristic	This pattern is used in general applications. Used when the load torque is fixed, regardless of rotation speed, for linear transport systems.	0	50 Hz specifications
		1 (F)	60 Hz specifications
		2	60 Hz specifications, voltage saturation at 50 Hz
		3	72 Hz specifications, voltage saturation at 60 Hz
Variable torque characteristic	This pattern is used for loads with torque proportional to two or three times the rotation speed, such as fans and pumps.	4	50 Hz specifications, × 3 decrement
		5	50 Hz specifications, × 2 decrement
		6	60 Hz specifications, × 3 decrement
		7	60 Hz specifications, × 2 decrement

Characteristic	Application	Set Value	Specifications
High Startup Torque (See Note)*	Select the high startup torque V/f pattern only in the following cases. <ul style="list-style-type: none"> • The wiring distance between Inverter and motor is large (approx. 150 m min.) • A large torque is required at startup (elevator loads, etc.) • An AC reactor is inserted in the Inverter input or output. • You are operating a motor that is less than optimum. 	8	50 Hz specifications, medium startup torque
		9	50 Hz specifications, large startup torque
		A	60 Hz specifications, medium startup torque
		B	60 Hz specifications, large startup torque
Fixed Output Operation	This pattern is used for frequencies of 60 Hz or higher. A fixed voltage is applied.	C	90 Hz specifications, voltage saturation at 60 Hz
		D	120 Hz specifications, voltage saturation at 60 Hz
		E	180 Hz specifications, voltage saturation at 60 Hz

* The torque is protected by the fully automatic torque boost function, so normally there is no need to use this pattern.

When you select these patterns, the values of constants E1-04 to E1-10 are changed automatically. There are three types of values for E1-04 to E1-10, depending on the Inverter capacity.

- 0.4 to 1.5 kW V/f pattern
- 2.2 to 45 kW V/f pattern
- 55 to 300 kW V/f pattern

The characteristics diagrams for each are shown in the following pages.

0.4 to 1.5 kW V/f Pattern

The diagrams show characteristics for a 200-V class motor. For a 400-V class motor, multiply all voltages by 2.

- Constant Torque Characteristics (Set Value: 0 to 3)

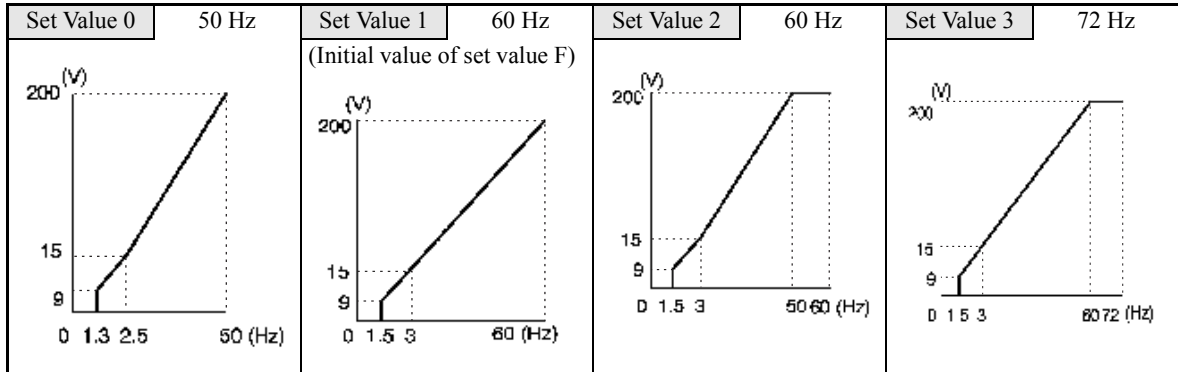

- Decrement Torque Characteristics (Set Value: 4 to 7)

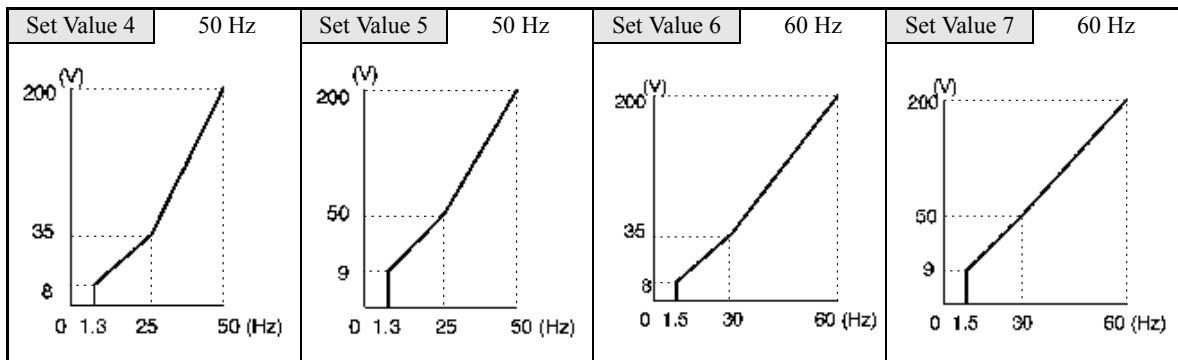

- High startup torque (Set value 8: to b)

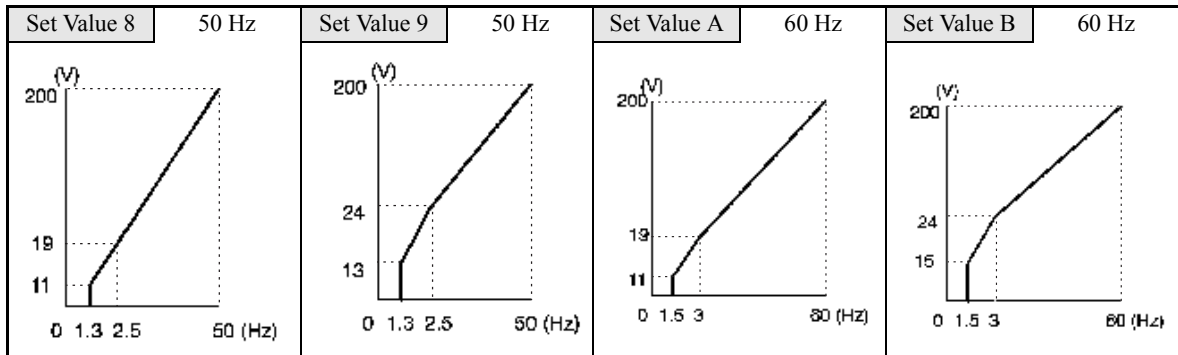

- Fixed Output Operation (Set Value: C to E)

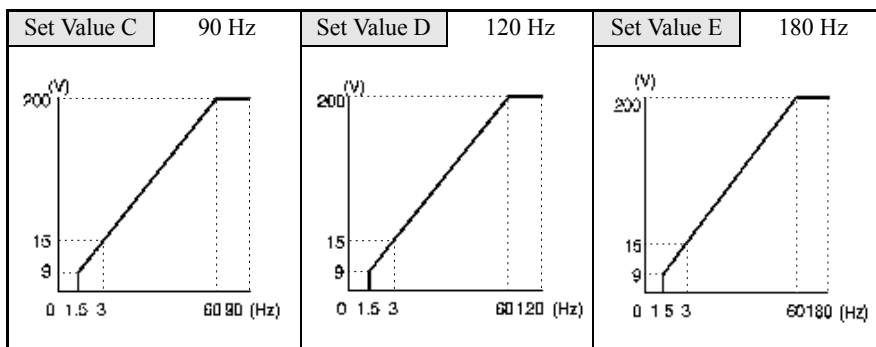

2.2 to 45 kW V/f Pattern

The diagrams show characteristics for a 200-V class motor. For a 400-V class motor, multiply all voltages by 2.

- Constant Torque Characteristics (Set Value: 0 to 3)

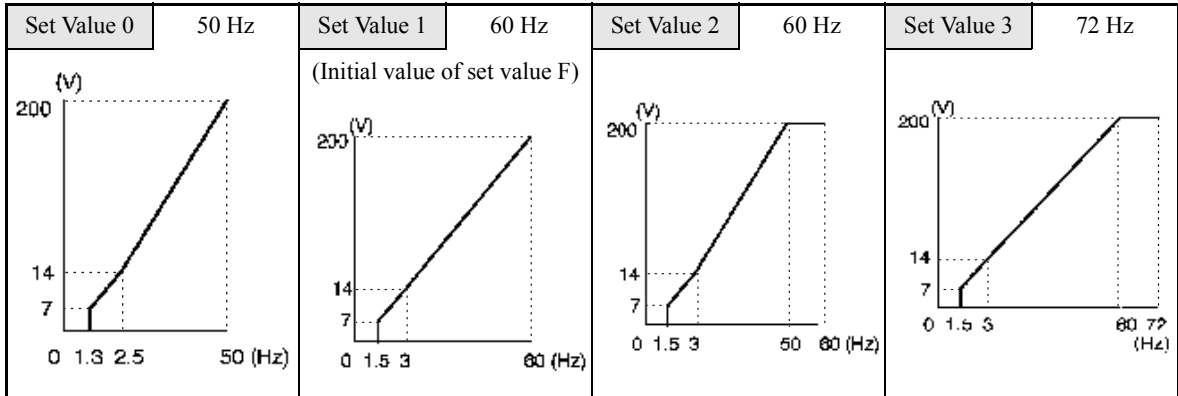

- Decrement Torque Characteristics (Set Value: 4 to 7)

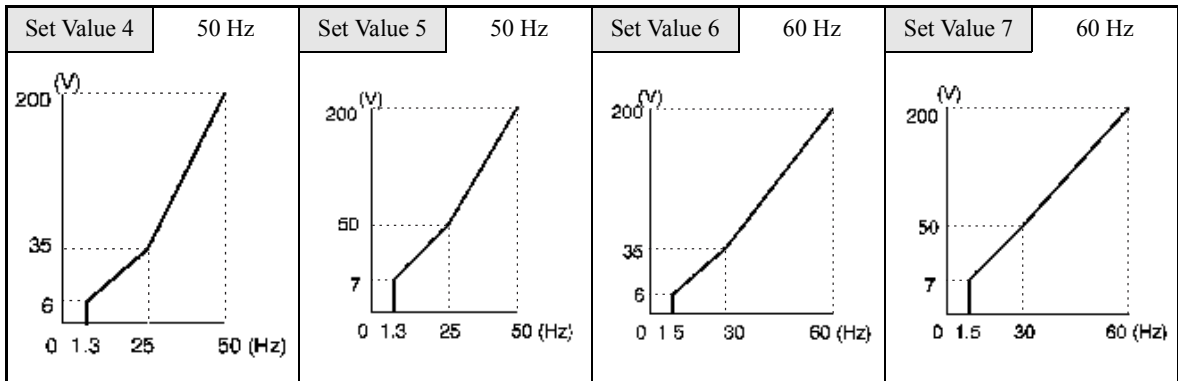

- High Startup Torque (Set Value: 8 to b)

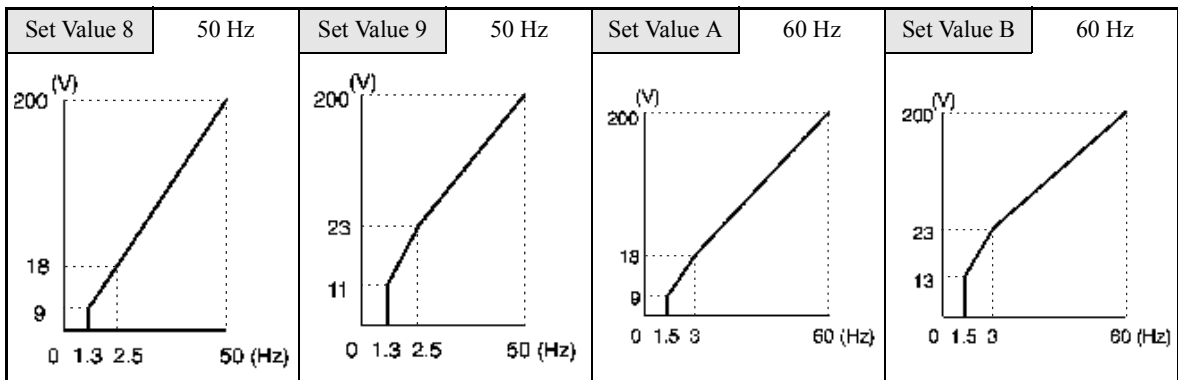

- Fixed Output Operation (Set Value: C to E)

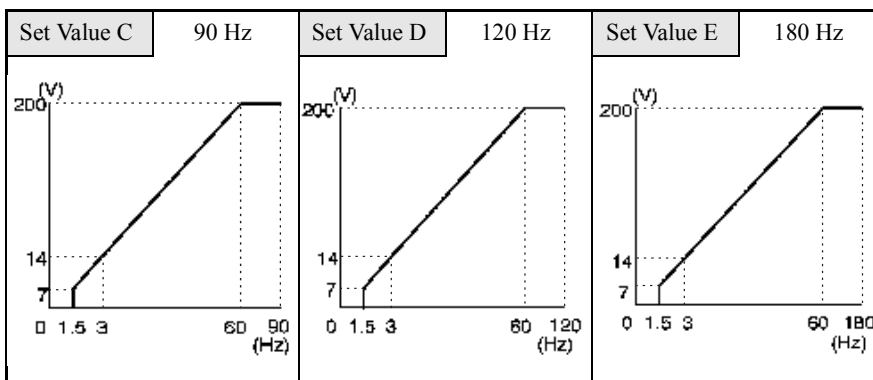

55 to 300 kW V/f Pattern

The diagrams show characteristics for a 200-V class motor. For a 400-V class motor, multiply all voltages by 2.

- Constant Torque Characteristics (Set Value: 0 to 3)

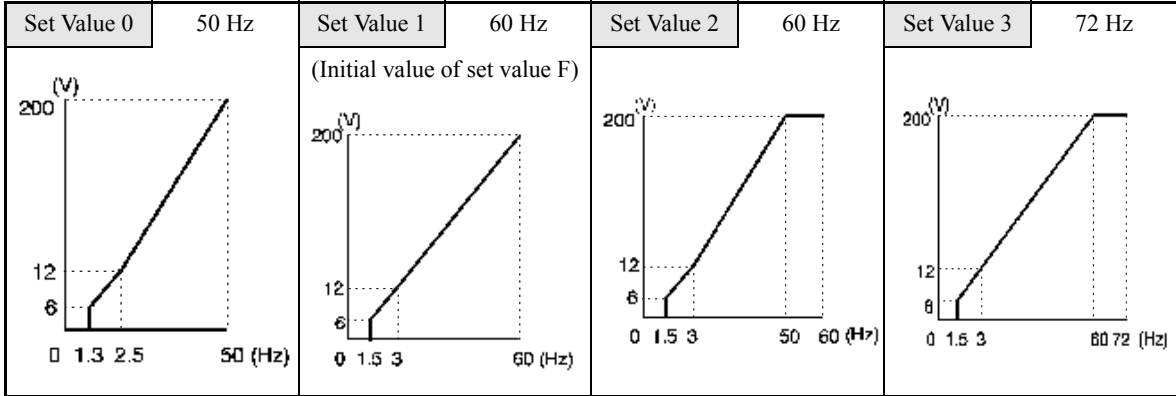

- Decrement Torque Characteristics (Set Value: 4 to 7)

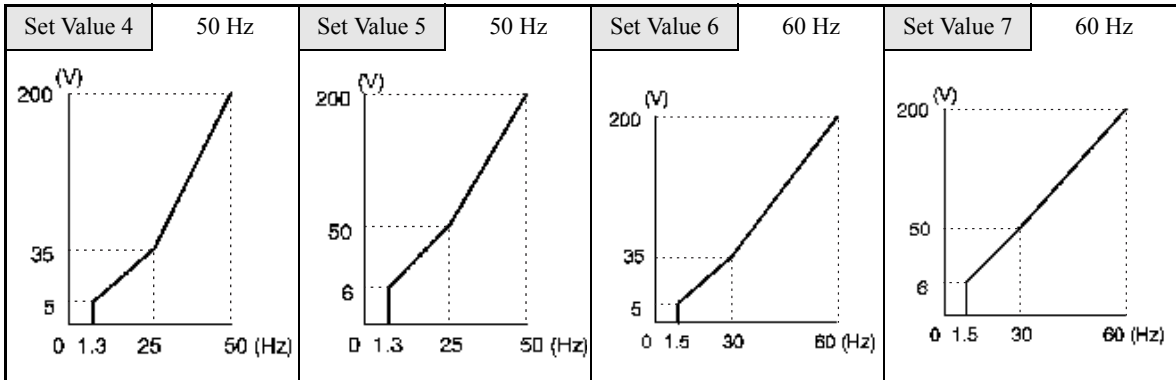

- High Startup Torque (Set Value: 8 to b)

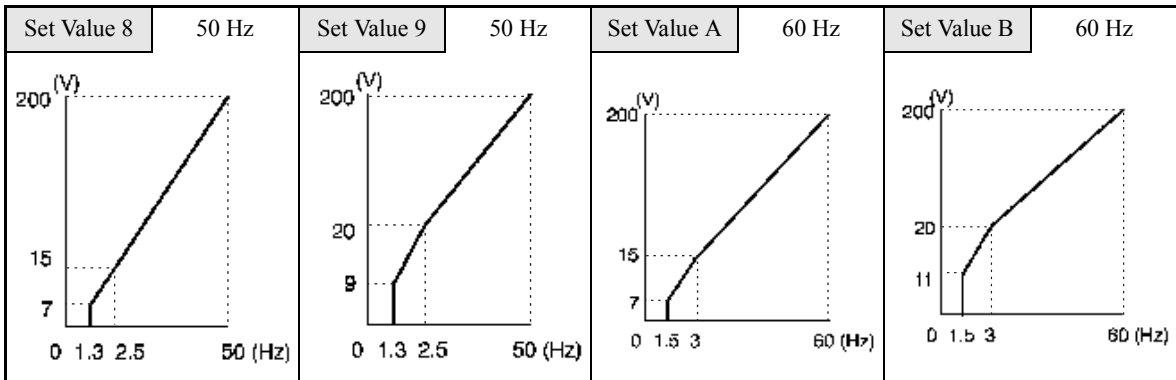

- Fixed Output Operation (Set Value: C to E)

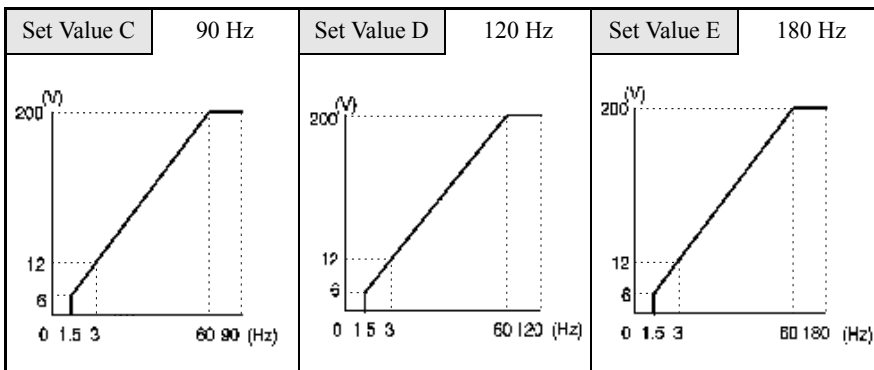

When E1-03 is set to F (User-defined V/f pattern), you can set constants E1-04 to E1-10. If E1-03 is set to anything other than F, you can only refer to constants E1-04 to E1-10. If the V/f characteristics are linear, set E1-07 and E1-09 to the same value. In this case, E1-08 will be ignored.

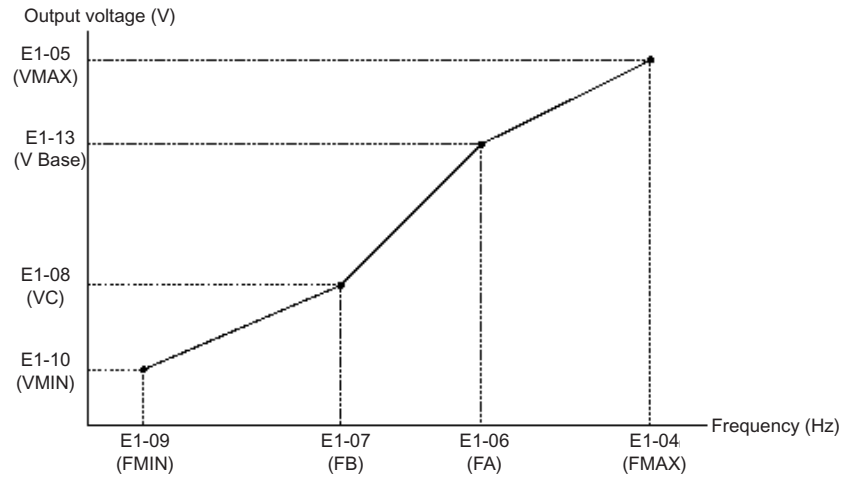

Fig 6.63 User-Set V/f Pattern

■ Setting Precautions

When the setting is to user-defined V/f pattern, beware of the following points.

- When changing control method, constants E1-07 to E1-10 will change to the factory settings for that control method.
- Be sure to set the four frequencies as follows:
 $E1-04 (FMAX) \geq E1-06 (FA) > E1-07 (FB) \geq E1-09 (FMIN)$

◆ Torque Control

With flux vector control or open-loop vector control 2, the motor's output torque can be controlled by a torque reference from an analog input. Set d5-01 to 1 to control torque.

■ Related Constants

Constant Number	Name	Description	Setting Range	Factory Setting	Change during Operation	Control Methods				
	Display					V/f	V/f with PG	Open Loop Vector 1	Flux Vector	Open Loop Vector 2
d5-01	Torque control selection	0: Speed control (C5-01 to C5-07) 1: 0 to -10 V, no lower limit To use the function for switching between speed and torque control, set to 0 and set the multi-function input to "speed/torque control change."	0 or 1	0	No	No	No	No	A	A
	Torq Control Sel									
d5-02	Torque reference delay time	Set the torque reference filter primary delay time in ms units. This function can be used to adjust the noise of the torque control signal or the responsiveness with the host controller. When oscillation occurs during torque control, increase the set value.	0 to 1000	0 ms*	No	No	No	No	A	A
	Torq Ref Filter									
d5-03	Speed limit selection	Set the speed limit command method for the torque control mode. 1: The analog input limit from a frequency reference 2: Limited by d5-04 constant setting values.	1 or 2	1	No	No	No	No	A	A
	Speed Limit Sel									
d5-04	Speed limit	Set the speed limit during torque control as a percentage of the maximum output frequency. This function is enabled when d5-03 is set to 2. Directions are as follows: +: Run command direction -: Opposite of run command	-120 to +120	0%	No	No	No	No	A	A
	Speed Lmt Value									
d5-05	Speed limit bias	Set the speed limit bias as a percentage of the maximum output frequency. Bias is applied to the specified speed limit. It can be used to adjust the margin for the speed limit.	0 to 120	10%	No	No	No	No	A	A
	Speed Lmt Bias									

Constant Number	Name	Description	Setting Range	Factory Setting	Change during Operation	Control Methods				
	Display					V/f	V/f with PG	Open Loop Vector 1	Flux Vector	Open Loop Vector 2
d5-06	Speed/torque control switching timer	Set the delay time from inputting the multi-function input "speed/torque control change" (from ON to OFF or OFF to ON) until the control is actually changed in ms units. This function is enabled when the multi-function input "speed/torque control change" is set. In the speed/torque control switching timer, the analog inputs hold the values of when the "speed/torque control change" changes. Always be sure to allow time for this process to finish completely.	0 to 1000	0 ms	No	No	No	No	A	A
	Ref Hold Time									
H3-04	Signal level selection (terminal A3)	0: 0 to ± 10 V [11-bit + polarity (positive/negative) input] 1: 0 to ± 10 V	0 or 1	0	No	A	A	A	A	A
	Term A3 Signal									
H3-05	Multi-function analog input (terminal A3)	Select from the functions listed in the following table. Refer to the next page.	0 to 1F	2	No	A	A	A	A	A
	Terminal A3 Sel									
H3-06	Gain (terminal A3)	Sets the input gain (level) when terminal 16 is 10 V. Set according to the 100% value selected from H3-05.	0.0 to 1000.0	100.0%	Yes	A	A	A	A	A
	Terminal A3 Gain									
H3-07	Bias (terminal A3)	Sets the input gain (level) when terminal 16 is 0 V. Set according to the 100% value selected from H3-05.	-100.0 to +100.0	0.0%	Yes	A	A	A	A	A
	Terminal A3 Bias									
H3-08	Multi-function analog input terminal A2 signal level selection	0: Limit negative frequency settings for gain and bias settings to 0. 1: Do not limit negative frequency settings for gain and bias settings to 0 (i.e., allow reverse operation). 2: 4 to 20 mA (9-bit input). Switch current and voltage input using the switch on the control panel.	0 to 2	2	No	A	A	A	A	A
	Term A2 Signal									
H3-09	Multi-function analog input terminal A2 function selection	Select multi-function analog input function for terminal A2. Refer to the next table.	0 to 1F	0	No	A	A	A	A	A
	Terminal A2 Sel									
H3-10	Gain (terminal A2)	Sets the input gain (level) when terminal 14 is 10 V (20 mA). Set according to the 100% value for the function set for H3-09.	0.0 to 1000.0	100.0%	Yes	A	A	A	A	A
	Terminal A2 Gain									

Constant Number	Name	Description	Setting Range	Factory Setting	Change during Operation	Control Methods				
	Display					V/f	V/f with PG	Open Loop Vector 1	Flux Vector	Open Loop Vector 2
H3-11	Bias (terminal A2)	Sets the input gain (level) when terminal 14 is 0 V (4 mA). Set according to the 100% value for the function set for H3-09.	-100.0 to +100.0	0.0%	Yes	A	A	A	A	A
	Terminal A2 Bias									

* Factory settings will change if the control mode is changed.

Multi-function Contact Input Functions (H1-01 to H1-10)

Setting Value	Function	Control Methods				
		V/f	V/f with PG	Open Loop Vector 1	Flux Vector	Open Loop Vector 2
71	Speed/torque control change (ON: Torque control)	No	No	No	Yes	Yes
78	Polarity reverse command for external torque reference	No	No	No	Yes	Yes

Multi-function Contact Output Functions (H2-01 to H2-05)

Setting Value	Function	Control Methods				
		V/f	V/f with PG	Open Loop Vector 1	Flux Vector	Open Loop Vector 2
32	Speed control circuit operating for torque control (except when stopped). The external torque reference will be limited if torque control is selected. Output when the motor is rotating at the speed limit.	No	No	No	Yes	Yes

Multi-function Analog Inputs (H3-05, H3-09)

Setting Value	Function	Control Methods				
		V/f	V/f with PG	Open Loop Vector 1	Flux Vector	Open Loop Vector 2
0	Add to terminal A1	Yes	Yes	Yes	Yes	Yes
13	Torque reference/torque limit at speed control	No	No	No	Yes	Yes
14	Torque compensation	No	No	No	Yes	Yes

Monitor Function

Constant Number	Name	Description	Output Signal Level During Multi-Function Analog Output	Min. Unit	Control Methods				
	Display				V/f	V/f with PG	Open Loop Vector 1	Flux Vector	Open Loop Vector 2
U1-09	Torque reference	Monitor in internal torque reference value for vector control.	10 V: Motor rated torque (0 to ± 10 V possible)	0.1%	No	No	A	A	A
	Torque Reference								

■ Inputting Torque References and Torque Reference Directions

The torque reference can be changed according to an analog input by setting H3-09 (Multi-function analog input terminal A2 selection) or H3-05 (Multi-function analog input terminal A3 selection) to 13 (torque reference) or 14 (torque compensation). The torque reference input methods are listed in the following table.

Torque Reference Input Method	Reference Location	Selection Method	Remarks
Voltage input (0 to ±10 V)	Between A3 and AC	H3-04 = 1 H3-05 = 13	Set H3-04 to 0 for a 0 to 10-V torque reference. To switch the torque reference between positive and negative torque, set a multi-function analog input to 78.
	Between A2 and AC (Turn OFF pin 2 of SW1.)	H3-08 = 1 H3-09 = 13	Set H3-08 to 0 for a 0 to 10-V torque reference. To switch the torque reference between positive and negative torque, set a multi-function analog input to 78. The input can be used for torque compensation by setting H3-09 to 14.
Current input (4 to 20 mA)	Between A2 and AC (Turn ON pin 2 of SW1.)	H3-08 = 2 H3-09 = 13	To switch the torque reference between positive and negative torque, set a multi-function analog input to 78. The input can be used for torque compensation by setting H3-09 to 14.
Option Card (AI-14B) (0 to ±10 V)	Between TC2 and TC4	F2-01 = 0 H3-08 = 1 H3-09 = 13	The input can be used for torque compensation by setting H3-05 to 14.

The direction of the torque output from the motor will be determined by the sign of the analog signal input. It does not depend on the direction of the run command. The direction of torque will be as follows:

- Positive analog reference: Torque reference for forward motor rotation (counterclockwise as viewed from the motor output axis).
- Negative analog reference: Torque reference for reverse motor rotation (clockwise as viewed from the motor output axis).

Application Precautions

If the analog signal input level is 0 to 10 V or 4 to 20 mA, a forward torque reference will not be applied. To apply reverse torque, use an input level of -10 V to 10 V or switch the direction using a multi-function input set to 78 (polarity reverse command for external torque reference).

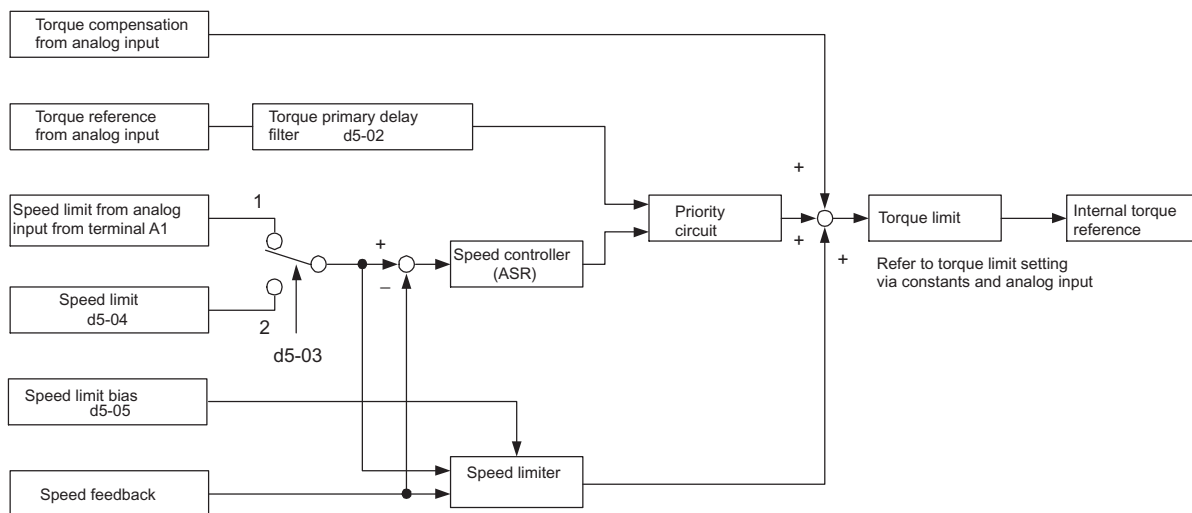

Fig 6.64 Torque Control Block Diagram

■ Speed Limiter and Priority Circuit (Speed Limit Function)

If the external torque reference and load are not balanced during torque control, the motor will accelerate in either the forward or reverse direction. The speed limit function is used to limit the speed to a specified value and it consists of the speed limiter circuit and priority circuit. The speed limit circuit

Application Precautions

There are two ways to set a speed limit: using an input from an analog input terminal and setting a speed limit in d5-04. The inputs methods for a speed limit are listed in the following table.

Speed Limit Input Method	Location of Reference	Constant Settings	Remarks
Voltage input (0 to ±10 V)	Set in d5-04	d5-03 = 2	-
	Between A1 and AC	b1-01 = 1 H3-01 = 1	Set H3-01 to 0 if the speed limit is always to be positive.
	Between A2 and AC	b1-01 = 0 H3-08 = 1 H3-09 = 1	The value will be added to the value input on A1 to determine the speed limit. Set H3-03 to 0 if the speed limit input on A2 is always to be positive. Turn OFF (V side) pin 2 of DIP switch S1 on the terminal board.
Current input (4 to 20 mA)	Between A2 and AC	b1-01 = 0 H3-08 = 2 H3-09 = 1	The value will be added to the value input on A1 to determine the speed limit. Turn ON (I side) pin 2 of DIP switch S1 on the terminal board.
Option Card (AI-4B) (0 to ±10 V)	Between TC1 and TC4	b1-01 = 3 F2-01 = 0	If H3-09 is set to 0, the sum of the input between TC2 and TC4 will be added the input between TC1 and TC4 to determine the speed limit.



IMPORTANT

The direction in which speed is controlled is determined by the sign of the speed limit signal and the direction of the run command.

- Positive voltage applied: The speed in the forward direction will be limited for forward operation.
- Negative voltage applied: The speed in the reverse direction will be limited for reverse operation.

If the direction of motor rotation and the command direction are not the same, speed will be limited to 0 as long as b5-05 is set to 0.

■ Speed Limit Bias Setting

The speed limit bias can be set to limit both the forward and reverse speed to the same value. This differs from the operation of the speed limit setting. To use the speed limit bias, set d5-04 to 0 and set the bias in d5-05 as a percentage of the maximum output frequency.

To set 50% forward and reverse speed limits, set the speed limit setting to 0 (d5-03 = 2, d5-04 = 0, and d5-05 = 50). The range of torque control will be from -50% to 50% of the maximum output speed.

When using both the speed limit and the speed limit bias, the range of torque control will be positive and negative speed limits with the speed limit bias added to each.

The range of torque control when the forward speed limit is 50% and the speed limit bias is 10% is shown in the following figure. This figure does not take the priority circuit into account.

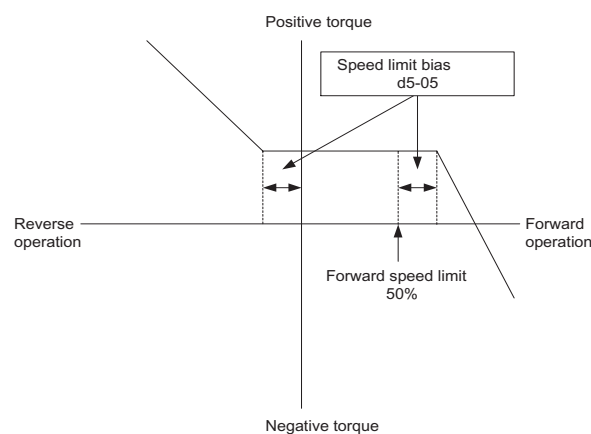

Fig 6.65 Speed Limit Bias Setting

■ Torque Limit Operation Examples

Operation examples will be described separately for winding operation, in which the speed and motor torque are in the same directions, and rewinding operation, in which the speed and motor torque are in opposite directions.

Winding Operation

In a winding operation, the line (speed) and torque generated by the motor are in the same direction. For the winding operation, both the speed limit and the torque reference input are positive. The motor will accelerate when the torque reference input is larger than the load and will decelerate when it is smaller than the load. If the motor turns faster than the speed limit, a negative compensation value is output from the speed limiter circuit. When the speed then drops below the speed limit, a positive compensation value is output. The torque compensation is proportional to the ASR proportional gain. When the sum of the torque reference and the torque compensation output by the speed limiter is the same as the actual load, the motor will stop accelerating and run at a constant speed.

Rewinding Operation

In a rewinding operation, the line (speed) and torque generated by the motor are in the opposite directions. (In this example, we'll assume that the line speed is positive and the torque reference input is negative.) For the rewinding operation, the speed limit is positive and the torque reference input is negative. If the motor turns faster than the speed limit, a negative compensation value is output from the speed limiter circuit. If the motor is rotating in reverse, a negative compensation value is output. If the speed is 0 or is below the speed limit, a 0 compensation value is output. In this way, the output from the speed limiter is used to maintain the motor speed between 0 and the speed limit. When the sum of the torque reference and the torque compensation output by the speed limiter is the same as the actual load, the motor will stop accelerating and run at a constant speed.

	Winding Operation		Rewinding Operation	
Configuration				
Normal Rotation Direction	Forward	Reverse	Forward	Reverse
Torque Reference Polarity (TREF)	⊕	⊖	⊖	⊕
Speed Limit Polarity (SLIM)	⊕	⊖	⊕	⊖
Generated Torque	$\Delta N(\%) = \frac{TREF(\%)}{C5-01}$	$\Delta N(\%) = \frac{TREF(\%)}{C5-01}$	$\Delta N(\%) = \begin{cases} TREF(\%) \\ C5-01 \\ d5-05(\%) \end{cases} \text{ The smaller of these}$	$\Delta N(\%) = \begin{cases} TREF(\%) \\ C5-01 \\ d5-05(\%) \end{cases} \text{ The smaller of these}$

■ Torque Reference Adjustment

Consider the following information when adjusting the torque.

Torque Reference Delay Time: d5-02

The time constant of the primary filter in the torque reference section can be adjusted. This constant is used to eliminate noise in the torque reference signal and adjust the responsiveness to the host controller. Increase the setting if oscillation occurs during torque control.

Setting the Torque Compensation

Set multi-function analog input A2 or A3 to torque compensation (setting 14). When the amount of torque loss for mechanical loss or other factor at the load is input to one of these terminals, it is added to the torque reference to compensate for the loss. The direction of torque will be as follows:

- Positive voltage (current): Torque compensation reference for forward motor rotation (counterclockwise as viewed from the motor output axis).

- Negative voltage: Torque compensation reference for reverse motor rotation (clockwise as viewed from the motor output axis).

Since the polarity of the voltage input determines the direction, only forward torque compensation can be input when the 0 to 10 V or 4 to 20 mA signal level has been selected. If you want to input reverse torque compensation, be sure to select the 0 to ± 10 V signal level.

■Speed/Torque Control Switching Function

It is possible to switch between speed control and torque control when one of the multi-function inputs (H1-01 to H1-10) is set to 71 (Speed/Torque Control Change). Speed control is performed when the input is OFF and torque control is performed when the input is ON. Set d5-01 to switch speed/torque control.

■Setting the Speed/Torque Control Switching Timer

The delay between a change in the speed/control switching function input (ON to OFF or OFF to ON) and the corresponding change in the control mode can be set in d5-06. During the timer delay, the value of the 3 analog inputs will retain the values they had when the ON/OFF status of speed/torque control switching signal was changed. Use this delay to complete any changes required in external signals.

Application Precautions

- The frequency reference (during speed control) is set in b1-01. The speed limit during torque control is set in d5-03.
- If the torque reference has been assigned to a multi-function analog input, terminal A2, or terminal A3, the input function changes when the control mode is switched between torque control and speed control.
During speed control: The analog input terminal is used as the torque limit input.
During torque control: The analog input terminal is used as the torque reference input.
- When the run command turns OFF, the control method when stopped will be for speed control. Even from the torque control mode, the system will automatically change to speed control and decelerate to a stop when the run command turns OFF.
- When A1-02 (control method selection) is set to 3 (flux vector control), the speed/torque change command (a setting of 71) can be set for a multi-function input (H1-01 to H1-10) to switch between speed and torque control during operation. An example is shown below.

Terminal No.	User Constant No.	Factory Setting	Setting	Function
8	H1-06	8	71	Speed/torque control change
A1	b1-01	1	1	Frequency reference selection (terminals A1, A2)
	C5-03	1	1	Speed limit (terminals A1, A2)
A3	H3-05	0	13	Torque reference/torque limit

A timing chart for switching between speed and torque control is shown in the following figure.

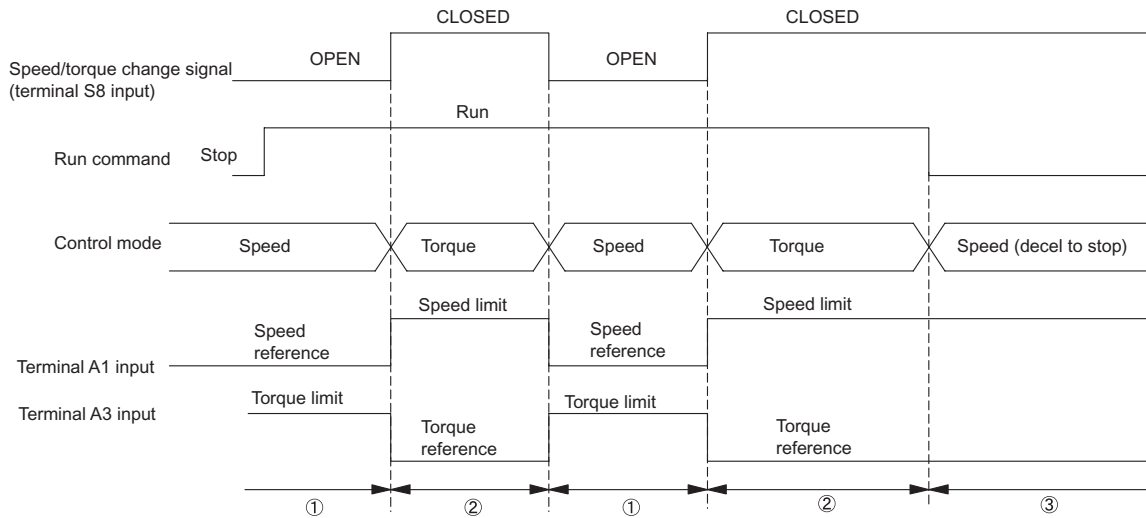
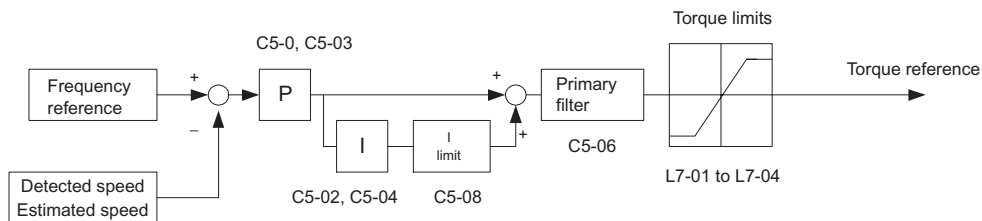

Fig 6.66 Speed/Torque Control Switching Time Chart.

◆ Speed Control (ASR) Structure

Speed control (ASR) during vector control adjusts the torque reference so that the deviation between the speed reference and the estimated speed (PG feedback or speed estimator) is 0. Speed control (ASR) during V/f control with a PG adjusts the output frequency so that the deviation between the speed reference and the estimated speed (PG feedback or speed estimator) is 0. The following block diagram shows the structure of the speed control for vector or V/f control with a PG.



Speed Control Block Diagram for Vector Control

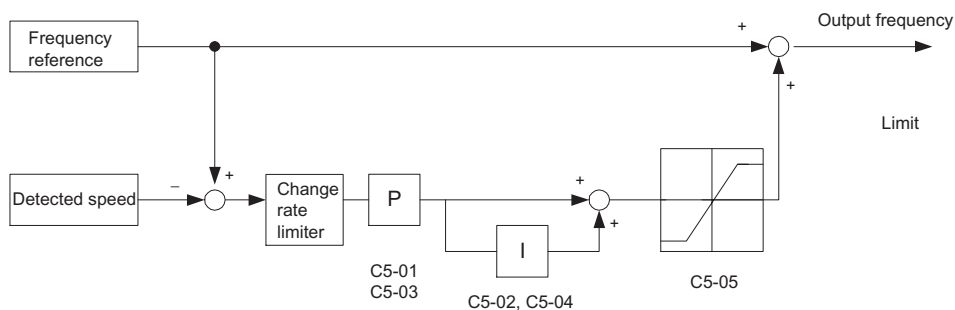

Speed Control Block Diagram for V/f Control with a PG

Fig 6.67 Speed Control Block Diagrams

■ Related Constants

Constant Number	Name	Description	Setting Range	Factory Setting	Change during Operation	Control Methods				
	Display					V/f	V/f with PG	Open Loop Vector 1	Flux Vector	Open Loop Vector 2
C5-01	ASR proportional gain 1	Sets the proportional gain of the speed loop (ASR.)	0.00 to 300.00 *2	20.00 *1	Yes	No	A	No	A	A
	ASR P Gain 1									
C5-02	ASR integral (I) time 1	Sets the integral time of the speed loop (ASR) in 1-second units.	0.000 to 10.000	0.500 s*1	Yes	No	A	No	A	A
	ASR I Time 1									
C5-03	ASR proportional gain 2	Usually setting is not necessary. Set to change the rotational speed gain.	0.00 to 300.00 *2	20.00 *1	Yes	No	A	No	A	A
	ASR P Gain 2									
C5-04	ASR integral (I) time 2		0.000 to 10.000	0.500 s*1	Yes	No	A	No	A	A
	ASR I Time 2									
C5-05	ASR limit	Sets the upper limit for the compensation frequency for the speed control loop (ASR) to a percentage of the maximum output frequency.	0.0 to 20.0	5.0%	No	No	A	No	No	No
	ASR Limit									
C5-06	ASR primary delay time	Sets the filter time constant, the time from the speed loop to the torque command output, in units of 1-second. Usually setting is not necessary.	0.000 to 0.500	0.004 *1	No	No	No	No	A	A*1
	ASR Delay Time									
C5-07	ASR switching frequency	Set the frequency for switching between Proportion Gain 1, 2 and Integral Time 1, 2 in Hz units. Speed control (ASR) proportional gain switching for a multi-function input takes priority.	0.0 to 400.0	0.0	No	No	No	No	A	A
	ASR Gain SW Freq									
C5-08	ASR integral (I) limit	Set the upper limit of the speed control loop integral as a percentage of the value at the rated load.	0 to 400	400	No	No	No	No	A	A
	ASR I Limit									

* 1. When the control method is changed, the Inverter reverts to factory settings. (Refer to section on constants with factory setting that depend on the control mode.)

* 2. The setting range is 1.00 to 3.00 for flux vector control and open-loop vector control 2.

Multi-function Contact Input Functions (H1-01 to H1-10)

Setting Value	Function	Control Methods				
		V/f	V/f with PG	Open Loop Vector 1	Flux Vector	Open Loop Vector 2
D	Speed control disable setting for V/f control with PG OFF: Use speed control V/f control with PG ON: Do not use speed control for V/f control with PG	No	Yes	No	No	No

Setting Value	Function	Control Methods				
		V/f	V/f with PG	Open Loop Vector 1	Flux Vector	Open Loop Vector 2
E	Speed control integral reset Enables switching between PI and P control for the speed control loop.	No	No	No	Yes	Yes
77	Speed control (ASR) proportional gain switch (switching between C5-01 and C5-03) OFF: Use proportional gain in C5-01 ON: Use proportional gain in C5-03	No	No	No	Yes	Yes

■ Speed Control (ASR) Gain Adjustment for Vector Control

Use the following procedure to adjust C5-01 and C5-03 with the mechanical system and actual load connected.

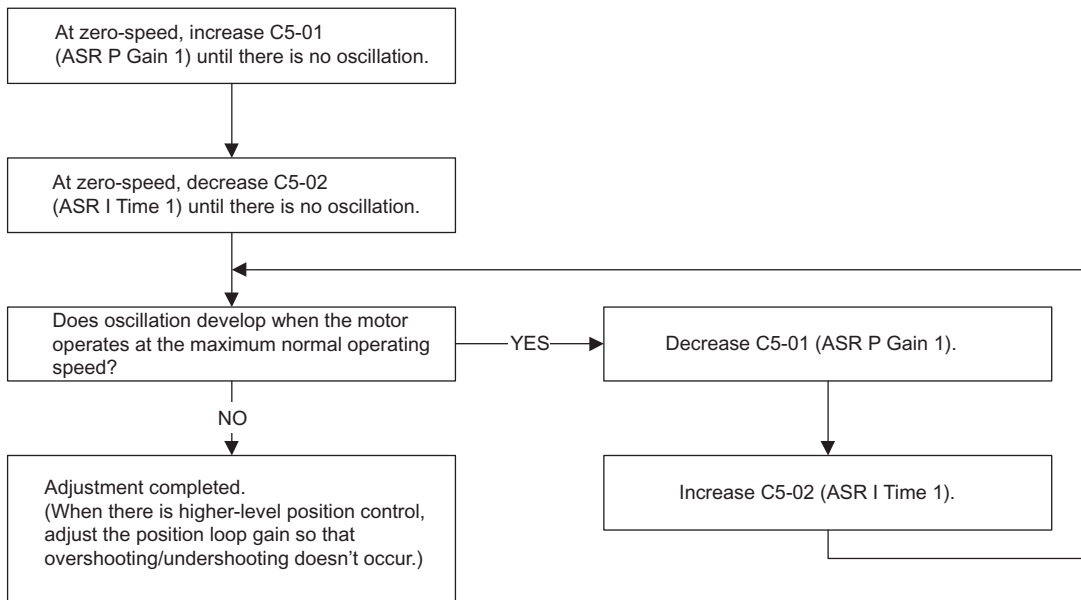

Fine Adjustments

When you want even finer gain adjustment, adjust the gain while observing the speed waveform. Constant settings like those shown in the following table will be necessary to monitor the speed waveform.

Constant No.	Name	Setting	Explanation
H4-01	Multi-function analog output 1 terminal FM monitor selection	2	Settings that allow multi-function analog output 1 to be used to monitor the output frequency.
H4-02	Multi-function analog output 1 terminal FM output gain	1.00	
H4-03	Multi-function analog output 1 terminal FM bias	0.0	
H4-04	Multi-function analog output 2 terminal AM monitor selection	5	Settings that allow multi-function analog output 2 to be used to monitor the motor speed.
H4-05	Multi-function analog output 2 terminal AM output gain	1.00	
H4-06	Multi-function analog output 2 terminal AM bias selection	0.00	
H4-07	Multi-function analog output 1 terminal signal level selection	1	Settings that allow a 0 to ± 10 V signal range to be monitored.
H4-08	Multi-function analog output 2 terminal signal level selection	1	

The multi-function analog outputs have the following functions with these constant settings.

- Multi-function analog output 1 (terminal FM): Outputs Inverter's output frequency (0 to ± 10 V).
- Multi-function analog output 2 (terminal AM): Outputs actual motor speed (0 to ± 10 V).

Terminal AC is the multi-function analog output common.

We recommend monitoring both the output frequency and the motor speed to monitor the response delay or deviations from the reference value, as shown in the following diagram.

Adjusting ASR Proportional Gain 1 (C5-01)

This gain setting adjusts the responsiveness of the speed control (ASR). The responsiveness is increased when this setting is increased. Usually this setting is higher for larger loads. Oscillation will occur if this setting is increased too much.

The following diagram shows the type of changes that can occur in the response when the ASR proportional gain is changed.

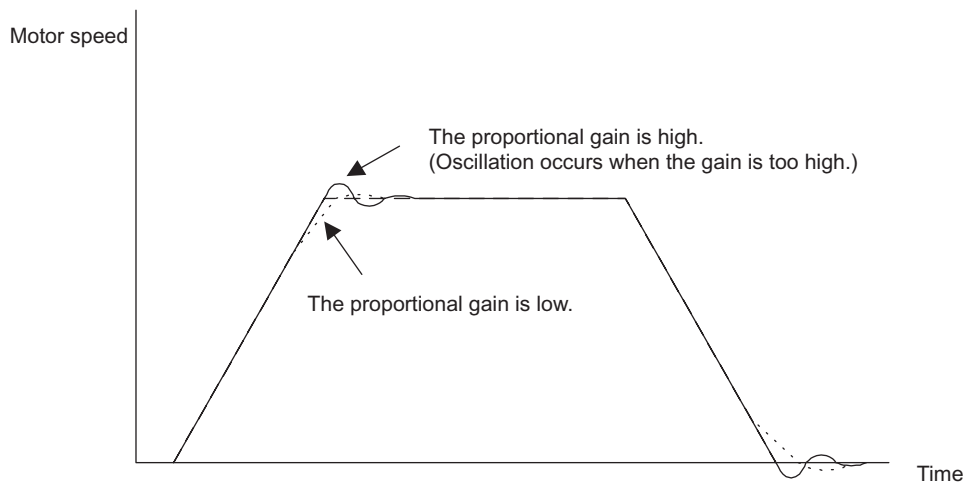

Fig 6.68 Responsiveness for Proportional Gain

Adjusting ASR Integral Time 1 (C5-02)

This constant sets the speed control (ASR) integral time.

Lengthening the integral time lowers the responsiveness, and weakens the resistance to external influences. Oscillation will occur if this setting is too short. The following diagram shows the type of changes that can occur in the response when the ASR integral time is changed.

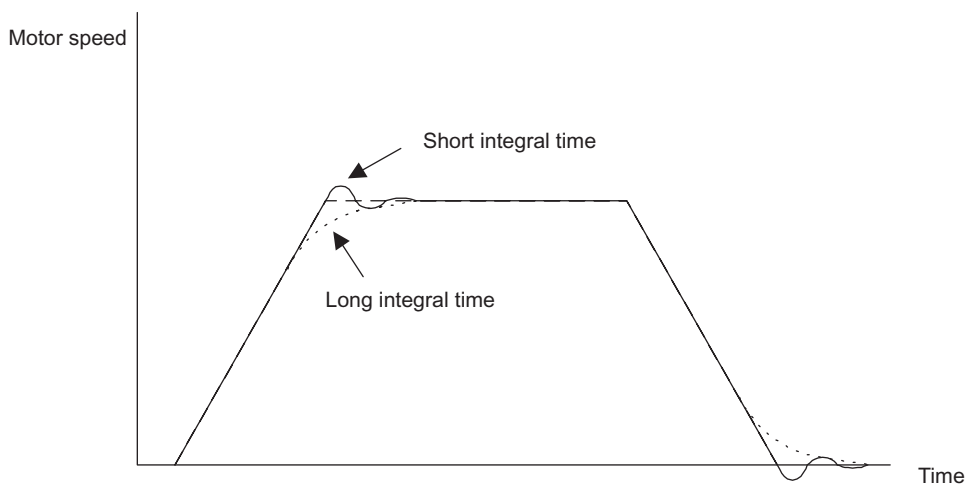

Fig 6.69 Responsiveness for Integral Time

Different Gain Settings for Low-speed and High-speed

Switch between low-speed and high-speed gain when oscillation occurs because of resonance with the mechanical system at low speed or high speed. The proportional gain P and integral time I can be switched according to the motor speed, as shown below.

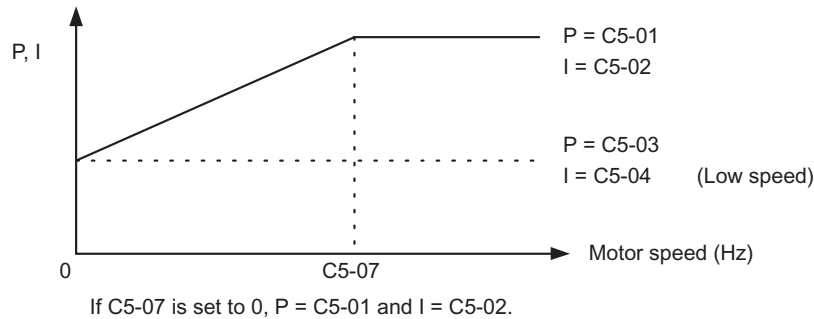

Fig 6.70 Low-speed and High-speed Gain Settings

Setting the Gain Switching Frequency (C5-07)

Set the switching frequency to about 80% of the motor operating frequency or the frequency at which oscillation occurs.

Low-speed Gain Adjustments (C5-03, C5-04)

Connect the actual load and adjust these constants at zero-speed. Increase C5-03 (ASR proportional gain 2) until there is no oscillation. Decrease C5-04 (ASR integral time 2) until there is no oscillation.

High-speed Gain Adjustments (C5-01, C5-02)

Adjust these constants at normal operating speed. Increase C5-01 (ASR proportional gain 1) until there is no oscillation. Decrease C5-02 (ASR integral time 1) until there is no oscillation. Refer to *Fine Adjustments* on page 6 - 124 for details on making fine adjustments of high-speed operation.

ASR Proportional Gain Switch Setting

When one of the multi-function inputs (H1-01 to H1-10) is set to 77, the input can be used to switch between C5-01 (proportional gain 1) and C5-03 (proportional gain 2). Proportional gain 2 is used when the multi-function input is ON. This input has higher priority than the ASR switching frequency set in C5-07.

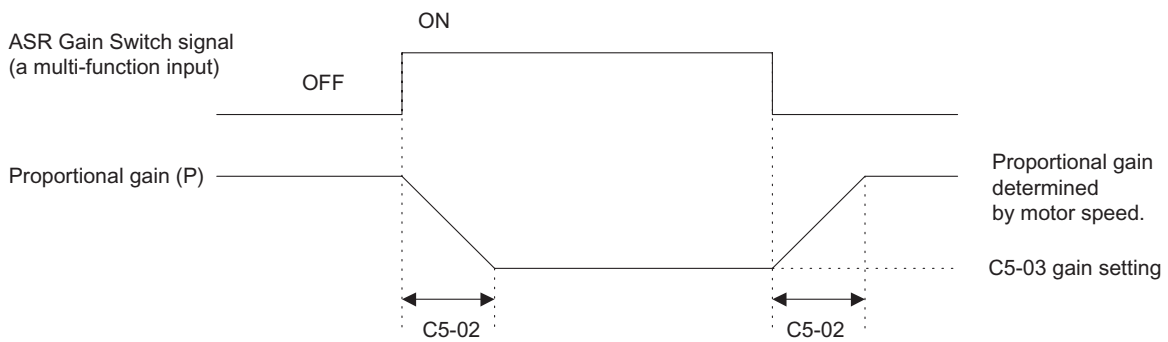

The gain is changed linearly in integral time 1 (C5-02).

Fig 6.71 ASR Proportional Gain Switch

■ Gain Adjustment for Speed Control during V/f Control with PG

When using V/f control with PG, set the proportional gain (P) and the integral time (I) at E1-09 (minimum output frequency) and E1-04 (maximum output frequency). Fig 6.72 *Speed Control Gain Integral Time Adjustment for V/f Control with PG* shows how the proportional gain and integral time change in linear fashion based on the speed.

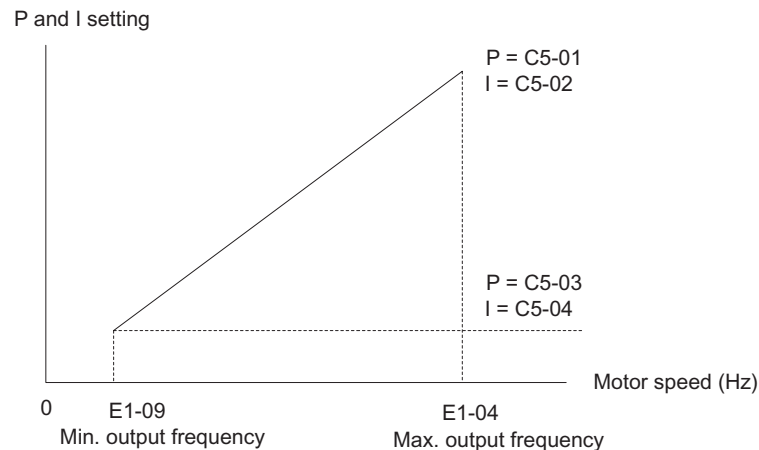

Fig 6.72 Speed Control Gain Integral Time Adjustment for V/f Control with PG

Gain Adjustments at Minimum Output Frequency

Operate the motor at the minimum output frequency. Increase C5-03 (ASR proportional gain 2) to a level where there is no oscillation. Decrease C5-04 (ASR integral time 2) to a level where there is no oscillation. Monitor the Inverter's output current and verify that it is less than 50% of the Inverter rated current. If the output current exceeds 50% of the Inverter's rated current, decrease C5-03 and increase C5-04.

Gain Adjustments at Maximum Output Frequency

Operate the motor at the maximum output frequency. Increase C5-01 (ASR proportional gain 1) to a level where there is no oscillation. Decrease C5-02 (ASR integral time 1) to a level where there is no oscillation.

Fine Adjustments

When you want even finer gain adjustment, adjust the gain while observing the speed waveform. The adjustment method is the same as that for vector control.

Enable integral operation during acceleration and deceleration (by setting F1-07 to 1) when you want the motor speed to closely follow the frequency reference during acceleration and deceleration. Reduce the setting of C5-01 if overshooting occurs during acceleration, and reduce the setting of C5-03 and increase the setting of C5-04 if undershooting occurs when stopping. If overshooting and undershooting cannot be eliminated by adjusting only the gain, reduce the value of C5-05 speed control and reduce the limit of the frequency reference compensation value.

◆ Droop Control Function

Droop control is a function that allows the user to set the amount of motor slip.

When a single load is operated with two motors (such as in a crane conveyor), a high-resistance motor is normally used. This is to use torque characteristics that exhibit proportion movements due to changes in the secondary resistor to maintain torque balance with the load and overall speed balance with the load.

If droop control is used, a high-resistance motor characteristics can be set for a general-purpose motor.

■ Related Constants

Constant Number	Name	Description	Setting Range	Factory Setting	Change during Operation	Control Methods				
	Display					V/f	V/f with PG	Open Loop Vector 1	Flux Vector	Open Loop Vector 2
b7-01	Droop control gain	Sets the slip as a percentage of maximum frequency when the maximum output frequency is specified and the rated torque occurs. Droop-control is not performed when the setting is 0.0.	0.0 to 100.0	0.0	Yes	No	No	No	A	A
	Droop Quantity									
b7-02	Droop control delay time	Droop control responsiveness constant When hunting or oscillation occurs, increase the value.	0.03 to 2.00	0.05 s	No	A	A	A	A	A
	Droop Delay Time									

■ Setting Precautions

- Droop control is disabled if b7-01 is set to 0.0.
- Set b7-01 to the amount of slip as the percentage of slip when the maximum output frequency is input and the rated torque is generated.
- Constant b7-02 is used to adjust the responsiveness of droop control. Increase this setting if oscillation or hunting occur.

■ Setting the Droop Control Gain

Set the droop control gain as the speed reduction at a 100% motor torque, as a percentage of the maximum output frequency.

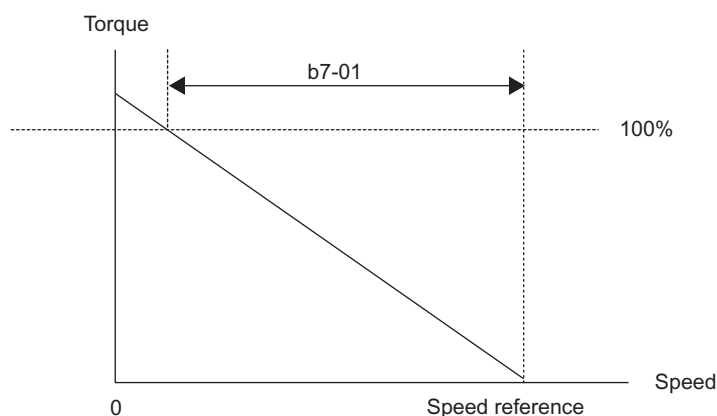

Fig 6.73 Droop Control Gain

◆ Zero-servo Function

The zero-servo function holds the motor when the motor is stopped in what is call a zero-servo status. This function can be used to stop the motor even with an external force acts on the motor or the analog reference input is offset.

The zero-servo function is enabled when one of the multi-function inputs (H1-01 to H1-10) is set to 72 (zero servo command). If the zero servo command is ON when the frequency (speed) reference falls below the zero speed level, a zero-servo status is implemented.

■Related Constants

Constant Number	Name	Description	Setting Range	Factory Setting	Change during Operation	Control Methods				
	Display					V/f	V/f with PG	Open Loop Vector 1	Flux Vector	Open Loop Vector 2
b2-01	Zero speed level (DC injection braking starting frequency)	Used to set the frequency which starts DC injection braking in units of Hz when deceleration to stop is selected. When b2-01 is less than E1-09, E1-09 becomes the DC injection braking starting frequency. (For flux vector control, zero-speed control from B2-01)	0.0 to 10.0	0.5 Hz	No	A	A	A	A	A
	DCInj Start Freq									
b9-01	Zero-servo gain	Adjust the strength of the zero-servo lock. Enabled when the zero-servo command is set for a multi-function input. When the zero-servo command has been input and the frequency reference drop below excitation level (b2-01), a position control loop is created and the motor stops. Increasing the zero-servo gain in turn increases the strength of the lock. Increasing it by too much will cause oscillation.	0 to 100	5	No	No	No	No	A	No
	Zero Servo Gain									
b9-02	Zero-servo completion width	Sets the output width of the P-lock completion signal. Enabled when the "zero-servo completion (end)" is set for a multi-function input. The zero-servo completion signal is ON when the current position is within the range (the zero-servo position + zero-servo completion width.) Set the allowable position displacement from the zero-servo position to 4 times the pulse rate of the PG (pulse generator, encoder) in use.	0 to 16383	10	No	No	No	No	A	No
	Zero Servo Count									

Multi-function Contact Input Functions (H1-01 to H1-10)

Setting Value	Function	Control Methods				
		V/f	V/f with PG	Open Loop Vector 1	Flux Vector	Open Loop Vector 2
72	Zero-servo command (ON: Zero-servo)	No	No	No	Yes	No

Multi-function Contact Output Functions (H2-01 to H2-03)

Setting Value	Function	Control Methods				
		V/f	V/f with PG	Open Loop Vector 1	Flux Vector	Open Loop Vector 2
33	Zero-servo end ON: Current position is within zero-servo start position \pm the zero-servo end width.	No	No	No	Yes	No

To output the zero-servo status externally, assign the Zero Servo End signal (setting 33) to one of the multi-function outputs (H2-01 to H2-03).

Monitor Function

Constant Number	Name	Description	Output Signal Level During Multi-Function Analog Output	Min. Unit	Control Methods				
	Display				V/f	V/f with PG	Open Loop Vector 1	Flux Vector	Open Loop Vector 2
U1-35	Zero-servo movement pulses	Shows the number of PG pulses times 4 for the movement range when stopped at zero.	(Cannot be output.)	1	No	No	No	A	No
	Zero Servo Pulse								

Time Chart

A time chart for the zero servo function is given in *Fig 6.74 Time Chart for Zero Servo*.

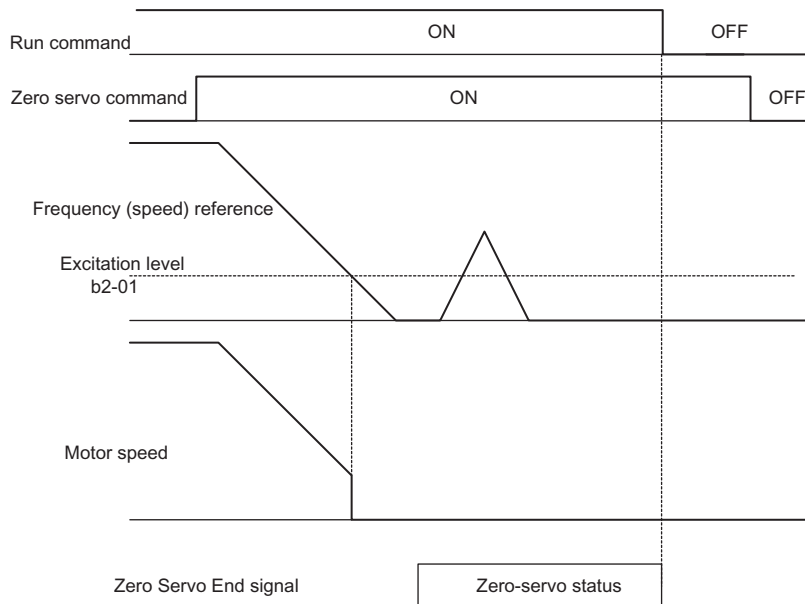

Fig 6.74 Time Chart for Zero Servo

Application Precautions

- Be sure to leave the run command input ON. If the run command is turned OFF, the output will be interrupted and the zero-servo function will become ineffective.

- The holding force of the zero-servo is adjusted in b9-01. The holding force will increase if the value of the setting is increased, but oscillation and hunting will occur if the setting is too large. Adjust b9-01 after adjusting the speed control gain.
- The zero-servo detection width is set as the allowable position offset from the zero-servo start position. Set 4 times the number of pulses from the PG.
- The Zero Servo End signal will go OFF when the zero servo command is turned OFF.



Do not lock the servo for extended periods of time at 100% when using the zero servo function. Inverter errors may result. Extended periods of servo lock can be achieved by ensuring that the current during the servolock is 50% or less or by increasing the Inverter capacity.

Digital Operator Functions

This section explains the Digital Operator functions.

◆ Setting Digital Operator Functions

You can set Digital Operator-related constants such as selecting the Digital Operator display, multi-function selections, and copy functions.

■ Related Constants

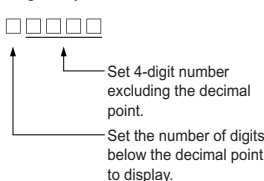
Constant Number	Name	Description	Setting Range	Factory Setting	Change during Operation	Control Methods				
	Display					V/f	V/f with PG	Open Loop Vector 1	Flux Vector	Open Loop Vector 2
o1-02	Monitor selection after power up	Sets the monitor item to be displayed when the power is turned on. 1: Frequency reference 2: Output frequency 3: Output current 4: The monitor item set for o1-01	1 to 4	1	Yes	A	A	A	A	A
	Power-On Monitor									
o1-03	Frequency units of reference setting and monitor	Sets the units that will be set and displayed for the frequency reference and frequency monitor. 0: 0.01 Hz units 1: 0.01% units (Maximum output frequency is 100%) 2 to 39: min^{-1} units (Sets the motor poles.) 40 to 39999: User desired display Set the desired values for setting and display for the max. output frequency.  Example: When the max. output frequency value is 200.0, set 12000	0 to 39999	0	No	A	A	A	A	A
	Display Scaling									
o1-04	Setting unit for frequency constants related to V/f characteristics	Set the setting unit for frequency reference-related constants. 0: Hz 1: min^{-1}	0 or 1	0	No	No	No	No	A	A
	V/f Display Unit									
o2-01	LOCAL/REMOTE key enable/disable	Sets the Digital Operator Local/Remote Key 0: Disabled 1: Enabled (Switches between the Digital Operator and the constant settings.)	0 or 1	1	No	A	A	A	A	A
	Local/Remote Key									

Con- stant Number	Name	Description	Setting Range	Factory Setting	Change during Opera- tion	Control Methods				
	Display					V/f	V/f with PG	Open Loop Vector 1	Flux Vec- tor	Open Loop Vector 2
o2-02	STOP key dur- ing control cir- cuit terminal operation	Sets the Stop Key in the run mode. 0: Disabled (When the run command is issued from and external terminal, the Stop Key is disabled.) 1: Enabled (Effective even during run.)	0 or 1	1	No	A	A	A	A	A
	Oper STOP Key									
o2-03	User constant initial value	Clears or stores user initial values. 0: Stores/not set 1: Begins storing (Records the set constants as user initial values.) 2: All clear (Clears all recorded user initial values) When the set constants are recorded as user initial values, 1110 will be set in A1-03.	0 to 2	0	No	A	A	A	A	A
	User Defaults									
o2-05	Frequency refer- ence setting method selec- tion	When the frequency reference is set on the Digital Operator fre- quency reference monitor, sets whether the Enter Key is neces- sary. 0: Enter Key needed 1: Enter Key not needed When set to 1, the Inverter accepts the frequency reference without Enter Key operation.	0 or 1	0	No	A	A	A	A	A
	Operator M.O.P.									
o2-07	Cumulative operation time setting	Sets the cumulative operation time in hour units. Operation time is calculated from the set values.	0 to 65535	0 hr	No	A	A	A	A	A
	Elapsed Time Set									
o2-10	Fan operation time setting	Set the initial value of the fan operation time using time units. The operation time accumulates from the set value.	0 to 65535	0 hr	No	A	A	A	A	A
	Fan ON Time Set									

■ Changing Frequency Reference and Display Units

Set the Digital Operator frequency reference and display units using constant o1-03. You can change the units for the following constants using o1-03.

- U1-01 (Frequency Reference)
- U1-02 (Output Frequency)
- U1-05 (Motor Speed)
- U1-20 (Output Frequency after Soft Start)
- d1-01 to d1-17 (Frequency references)

■ Switching Monitors when the Power Supply Is ON

Using constant o1-02, select the monitor item (U1-□□ [status monitor]) to be displayed on the Digital Operator when the power supply is turned ON. For monitors that can be displayed, refer to U1-□□ in *Chapter 5 User Constants*.

Setting Precautions

If selecting monitor constants other than U1-01 (Frequency Reference), U1-02 (Output Frequency), and U1-03 (Output Current), first select the monitor items to be displayed in o1-01, and then set o1-02 to 4.

■Disabling the STOP Key

If b1-02 (Operation Method Selection) is set to 1, 2, or 3, the stop command from the STOP Key on the Digital Operator is an emergency stop command.

Set o2-02 to 0 to disable emergency stop commands from the STOP Key on the Digital Operator.

■Disabling the LOCAL/REMOTE Key

Set o2-01 to 0 to disable the LOCAL/REMOTE Key on the Digital Operator. You cannot switch Inverter reference inputs set using reference inputs from the Digital Operator, b1-01 (Reference Selection), or b1-02 (Operation Method Selection).

■Initializing Changed Constant Values

You can save to the Inverter constant set values that you have changed as constant initial values. Change the set values from the Inverter factory settings, and then set o2-03 to 1.

Set A1-03 (Initialize) to 1110 to initialize the Inverter constants using the user-set initial values in memory. To clear the user-set initial values in memory, set o2-03 to 2.

■Setting the Frequency Reference using the UP and DOWN Keys without Using the Enter Key

Use this function when inputting frequency references from the Digital Operator. When o2-05 is set to 1, you can increment and decrement the frequency reference using the UP and DOWN Keys without using the Enter Key.

For example, enter the Run command using a 0 Hz reference, and then continuously press the UP Key to increment the frequency reference by 0.01 Hz only for the first 0.5 s, and then by 0.01 Hz every 80 ms for 3 s thereafter. Press and hold down the UP Key for 3 s minimum to reach the maximum output frequency 10 s after that. The frequency reference that has been set will be stored in memory 5 s after the UP or DOWN Keys are released.

■Clearing Cumulative Operation Time

Set the cumulative operation time initial value in time units in constant o2-07. Set o2-07 to 0 to clear U1-13 (inverter Operating Time).

■Clearing Inverter Cooling Fan Operation Time

Set the fan operation time initial value in time units in constant o2-10. Set o2-10 to 0 to clear U1-40 (Cooling Fan Operating Time).

◆ Copying Constants

The Digital Operator can perform the following three functions using the built-in EEPROM (non-volatile memory).

- Store Inverter constant set values in the Digital Operator (READ)
- Write constant set values stored in the Digital Operator to the Inverter (COPY)
- Compare constant set values stored in the Digital Operator with Inverter constants (VERIFY)

■ Related Constants

Constant Number	Name	Description	Setting Range	Factory Setting	Change during Operation	Control Methods				
	Display					V/f	V/f with PG	Open Loop Vector 1	Flux Vector	Open Loop Vector 2
o3-01	Copy function selection	0: Normal operation 1: READ (Inverter to Operator) 2: COPY (Operator to Inverter) 3: Verify (compare)	0 to 3	0	No	A	A	A	A	A
	Copy Function Sel									
o3-02	Read permitted selection	0: Read prohibited 1: Read permitted	0 or 1	0	No	A	A	A	A	A
	Copy Allowable									

■ Storing Inverter Set Values in the Digital Operator (READ)

To store Inverter set values in the Digital Operator, make the settings using the following method.

Table 6.1 READ Function Procedure

Step No.	Digital Operator Display	Explanation
1	<pre> -ADV- ** Main Menu ** ----- Programming </pre>	Press the Menu Key, and select advanced programming mode.
2	<pre> -ADV- Initialization A1 - 00=1 ----- Select Language </pre>	Press the DATA/ENTER Key, and select the constants monitor display.
3	<pre> -ADV- COPY Function o3 - 01=0 ----- Copy Funtion Sel </pre>	Display o3-01 (Copy Function Selection) using the Increment Key and Decrement Key.
4	<pre> -ADV- Copy Funtion Sel o3-01=0 *0* ----- COPY SELECT </pre>	Press the DATA/ENTER Key, and select the constants setting display.
5	<pre> -ADV- Copy Funtion Sel o3-01=1 *0* ----- INV→OP READ </pre>	Change the set value to 1 using the Increment Key.
6	<pre> -ADV- READ INV→OP READING ----- </pre>	Set the changed data using the DATA/ENTER Key. The READ function will start.
7	<pre> -ADV- READ READ COMPLETE </pre>	If the READ function ends normally, End is displayed on the Digital Operator.
8	<pre> -ADV- Copy Funtion Sel o3 - 01=0 *0* ----- COPY SELECT </pre>	The display returns to o3-01 when a key is pressed.

An error may occur while saving to memory. If an error is displayed, press any key to cancel the error display and return to the o3-01 display.

Error displays and their meanings are shown below. (Refer to *Chapter 7 Errors when Using the Digital Operator Copy Function.*)

Error Display	Meaning
<pre> PRE READ IMPOSSIBLE </pre>	You are attempting to set o3-01 to 1 while o3-02 is set to 0.
<pre> IFE READ DATA ERROR </pre>	Read data length mismatch or read data error.

Error Display	Meaning
<div style="border: 1px solid black; padding: 5px; width: fit-content; margin: auto;"> RDE DATA ERROR </div>	Tried to write constants to EEPROM on the Digital Operator, but unable to perform write operation.

Select READ Permitted

Prevent overwriting the data stored in EEPROM in the Digital Operator by mistake. With o3-02 set to 0, if you set o3-01 to 1, and perform the write operation, PrE will be displayed on the Digital Operator, and the write operation will be stopped.

■ Writing Constant Set Values Stored in the Digital Operator to the Inverter (COPY)

To write constant set values stored in the Digital Operator to the Inverter, make the settings using the following method.

Table 6.2 COPY Function Procedure

Step No.	Digital Operator Display	Explanation
1	<div style="border: 1px solid black; padding: 5px; width: fit-content; margin: auto;"> -ADV- ** Main Menu ** ----- Programming </div>	Press the MENU Key, and select advanced programming mode.
2	<div style="border: 1px solid black; padding: 5px; width: fit-content; margin: auto;"> -ADV- Initialization ----- A1 - 00=1 Select Language </div>	Press the DATA/ENTER Key, and select the constants monitor display.
3	<div style="border: 1px solid black; padding: 5px; width: fit-content; margin: auto;"> -ADV- COPY Function ----- o3 - 01=0 Copy Funtion Sel </div>	Display o3-01 (Copy Function Selection) using the Increment Key and Decrement Key.
4	<div style="border: 1px solid black; padding: 5px; width: fit-content; margin: auto;"> -ADV- Copy Funtion Sel ----- o3-01= 0 *0* COPY SELECT </div>	Press the DATA/ENTER Key, and select the constants setting display.
5	<div style="border: 1px solid black; padding: 5px; width: fit-content; margin: auto;"> -ADV- Copy Funtion Sel ----- o3-01= 2 *0* OP→INV WRITE </div>	Change the set value to 2 using the Increment Key.
6	<div style="border: 1px solid black; padding: 5px; width: fit-content; margin: auto;"> -ADV- COPY OP→INV COPYING </div>	Set the changed data using the DATA/ENTER Key. The COPY function will start.
7	<div style="border: 1px solid black; padding: 5px; width: fit-content; margin: auto;"> -ADV- COPY COPY COMPLETE </div>	If the COPY function ends normally, End is displayed on the Digital Operator.
8	<div style="border: 1px solid black; padding: 5px; width: fit-content; margin: auto;"> -ADV- Copy Funtion Sel ----- o3 - 01=0 *0* COPY SELECT </div>	The display returns to o3-01 when a key is pressed.

During the copy operation, errors may occur. If an error is displayed, press any key to cancel the error display and return to the 03-01 display.

Error displays and their meanings are shown below. (Refer to *Chapter 7 Errors when Using Digital Operator Copy Function*.)

Error Display	Meaning
CPE ID UNMATCH	Inverter product code and Inverter software number are different.
VAE INV. KVA UNMATC	Inverter capacity with which you are trying to copy, and the Inverter capacity stored in the Digital Operator are different.
CRE CONTROL UNMATCH	The Inverter control method in which you are trying to copy, and the Inverter control method stored in the Digital Operator are different.
CYE COPY ERROR	Comparison between the constant written to the Inverter and the constant in the Digital Operator shows they are different.
CSE SUM CHECK ERROR	After copying has ended, comparison between the sum value of the Inverter constant area and the sum value of the Digital Operator constant area shows they are different.





■ Comparing Inverter Constants and Digital Operator Constant Set Values (VERIFY)

To compare Inverter constants and Digital Operator constant set values, make the settings using the following method.

Table 6.3 VERIFY Function Procedure

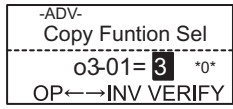
Step No.	Digital Operator Display	Explanation
1	-ADV- ** Main Menu ** ----- Programming	Press the MENU Key, and select advanced programming mode.
2	-ADV- Initialization ----- A1 - 00=1 Select Language	Press the DATA/ENTER Key, and select the constants monitor display.
3	-ADV- COPY Function ----- 03 - 01=0 Copy Funtion Sel	Display 03-01 (Copy Function Selection) using the Increment Key and Decrement Key.
4	-ADV- Copy Funtion Sel ----- 03-01= 0 *0* COPY SELECT	Press the DATA/ENTER Key, and select the function setting display.

Table 6.3 VERIFY Function Procedure

Step No.	Digital Operator Display	Explanation
5		Change the set value to 3 using the Increment Key.
6		Set the changed data using the DATA/ENTER Key. The VERIFY function will start.
7		If the VERIFY function ends normally, End is displayed on the Digital Operator.
8		The display returns to o3-01 when a key is pressed.

An error may occur during the comparison. If an error is displayed, press any key to cancel the error display and return to the o3-01 display. Error displays and their meanings are shown below. (Refer to *Chapter 7 Errors when Using Digital Operator Copy Function.*)

Error Display	Meaning
	Verify error (Settings in the Digital Operator and the Inverter do not match).

■ Application Precautions

When using the copy function, check that the following settings are the same between the Inverter and the Digital Operator.

- Inverter product and type
- Inverter capacity and voltage
- Software number
- Control method

◆ Prohibiting Writing Constants from the Digital Operator

If you set A1-01 to 0, you can refer to and set the A1 and A2 constant groups, and refer to drive mode, using the Digital Operator.

If you set one of the constants H1-01 to H1-05 (multi-function contact input terminal S3 to S7 function selection) to 1B (write constants permitted), you can write constants from the digital operator when the terminal that has been set is ON. When the set terminal is OFF, writing constants other than the frequency reference is prohibited. You can, however, reference constants.

Constant Number	Name	Description	Setting Range	Factory Setting	Change during Operation	Control Methods				
	Display					V/f	V/f with PG	Open Loop Vector 1	Flux Vector	Open Loop Vector 2
A1-01	Constant access level	Used to set the constant access level (set/read.) 0: Monitoring only (Monitoring drive mode and setting A1-01 and A1-04.) 1: Used to select user constant (Only constants set in A2-01 to A2-32 can be read and set.) 2: Advanced (Constants can be read and set in both quick programming mode and advanced programming (A) mode.)	0 to 2	2	Yes	A	A	A	A	A
	Access Level									

◆ Setting a Password

When a password is set in A1-05, if the set values in A1-04 and A1-05 do not match, you cannot refer to or change the settings of constants A1-01 to A1-03, or A2-01 to A2-32.

You can prohibit the setting and referencing of all constants except A1-00 by using the password function in combination with setting A1-01 to 0 (Monitor only).

■ Related Constants

Constant Number	Name	Description	Setting Range	Factory Setting	Change during Operation	Control Methods				
	Display					V/f	V/f with PG	Open Loop Vector 1	Flux Vector	Open Loop Vector 2
A1-01	Constant access level	Used to set the constant access level (set/read.) 0: Monitoring only (Monitoring drive mode and setting A1-01 and A1-04.) 1: Used to select user constant (Only constants set in A2-01 to A2-32 can be read and set.) 2: Advanced (Constants can be read and set in both quick programming mode and advanced programming (A) mode.)	0 to 2	2	Yes	A	A	A	A	A
	Access Level									
A1-04	Password	Password input when a password has been set in A1-05. This function write-protects some constants of the initialize mode. If the password is changed, A1-01 to A1-03 and A2-01 to A2-32 constants can no longer be changed. (Programming mode constants can be changed.)	0 to 9999	0	No	A	A	A	A	A
	Enter Password									

Constant Number	Name	Description	Setting Range	Factory Setting	Change during Operation	Control Methods				
	Display					V/f	V/f with PG	Open Loop Vector 1	Flux Vector	Open Loop Vector 2
A1-05	Password setting	Used to set a four digit number as the password.	0 to 9999	0	No	A	A	A	A	A
	Select Password	This constant is not usually displayed. When the Password (A1-04) is displayed, hold down the RESET Key and press the Menu Key and the password will be displayed.								

■ Setting Precautions

Constant A1-05 cannot be displayed using normal key operations. To display A1-05, hold down the RESET Key and press the MENU Key while A1-04 is displayed.

◆ Displaying User-set Constants Only

You can set and refer to constants necessary to the Inverter only, using the A2 constants (user-set constants) and A1-01 (Constants Access Level).

Set the number of the constant to which you want to refer in A2-01 to A2-32, and then set A1-01 to 1. You can set and refer to constants set in A1-01 to A1-03 and A2-01 to A2-32 only, using advanced programming mode.

■ Related Constants

Constant Number	Name	Description	Setting Range	Factory Setting	Change during Operation	Control Methods				
						V/f	V/f with PG	Open Loop Vector 1	Flux Vector	Open Loop Vector 2
A2-01 to A2-32	User setting constants	Used to set the constant numbers that can be set/read. Maximum 32.	b1-01 to o3-02	-	No	A	A	A	A	A
	User Param 1 to 32	Effective when the Constant Access Level (A1-01) is set to User Program (1). Constants set in constants A2-01 to A2-32 can be set/read in programming mode.								

Options

This section explains the Inverter option functions.

◆ Performing Speed Control with PG

This section explains functions with V/f control with PG.

■ Related Constants

Constant Number	Name	Description	Setting Range	Factory Setting	Change during Operation	Control Methods				
	Display					V/f	V/f with PG	Open Loop Vector 1	Flux Vector	Open Loop Vector 2
F1-01	PG constant	Sets the number of PG (pulse generator or encoder) pulses. Sets the number of pulses per motor revolution.	0 to 60000	600	No	No	Q	No	Q	No
	PG Pulses/Rev									
F1-02	Operation selection at PG open circuit (PGO)	Sets the PG disconnection stopping method. 0: Ramp to stop (Deceleration stop using Deceleration Time 1, C1-02.) 1: Coast to stop 2: Fast stop (Emergency stop using the deceleration time in C1-09.) 3: Continue operation (To protect the motor or machinery, do not normally make this setting.)	0 to 3	1	No	No	A	No	A	No
	PG Fdbk Loss Sel									
F1-03	Operation selection at overspeed (OS)	Sets the stopping method when an overspeed (OS) fault occurs. 0: Ramp to stop (Deceleration stop using Deceleration Time 1, C1-02.) 1: Coast to stop 2: Fast stop (Emergency stop using the deceleration time in C1-09.) 3: Continue operation (To protect the motor or machinery, do not normally make this setting.)	0 to 3	1	No	No	A	No	A	A
	PG Overspeed Sel									
F1-04	Operation selection at deviation	Sets the stopping method when a speed deviation (DEV) fault occurs. 0: Ramp to stop (Deceleration stop using Deceleration Time 1, C1-02.) 1: Coast to stop 2: Fast stop (Emergency stop using the deceleration time in C1-09.) 3: Continue operation (DEV is displayed and operation continued.)	0 to 3	3	No	No	A	No	A	A
	PG Deviation Sel									
F1-05	PG rotation	0: Phase A leads with forward run command. (Phase B leads with reverse run command.) 1: Phase B leads with forward run command. (Phase A leads with reverse run command.)	0 or 1	0	No	No	A	No	A	No
	PG Rotation Sel									

Constant Number	Name	Description	Setting Range	Factory Setting	Change during Operation	Control Methods				
	Display					V/f	V/f with PG	Open Loop Vector 1	Flux Vector	Open Loop Vector 2
F1-06	PG division rate (PG pulse monitor)	Sets the division ratio for the PG speed control card pulse output. Division ratio = (1 + n) / m (n=0 or 1 m=1 to 32) F1-06 = $\frac{\square}{n} \frac{\square\square}{m}$ This constant is only effective when a PG-B2 is used. The possible division ratio settings are: $1/32 \leq F1-06 \leq 1$.	1 to 132	1	No	No	A	No	A	No
	PG Output Ratio									
F1-07	Integral value during accel/ decel enable/ disable	Sets integral control during acceleration/deceleration to either enabled or disabled. 0: Disabled (The integral function isn't used while accelerating or decelerating; it is used at constant speeds.) 1: Enabled (The integral function is used at all times.)	0 or 1	0	No	No	A	No	No	No
	PG Ramp PI/I Sel									
F1-08	Overspeed detection level	Sets the overspeed detection method. Frequencies above that set for F1-08 (set as a percentage of the maximum output frequency) that continue to exceed this frequency for the time set in F1-09 are detected as overspeed faults.	0 to 120	115%	No	No	A	No	A	A
	PG Overspd Level									
F1-09	Overspeed detection delay time	Sets the overspeed detection method. Frequencies above that set for F1-08 (set as a percentage of the maximum output frequency) that continue to exceed this frequency for the time set in F1-09 are detected as overspeed faults.	0.0 to 2.0	0.0 s *	No	No	A	No	A	A
	PG Overspd Time									
F1-10	Excessive speed deviation detection level	Sets the speed deviation detection method. Any speed deviation above the F1-10 set level (set as a percentage of the maximum output frequency) that continues for the time set in F1-11 is detected as a speed deviation. Speed deviation is the difference between actual motor speed and the reference command speed.	0 to 50	10%	No	No	A	No	A	A
	PG Deviate Level									
F1-11	Excessive speed deviation detection delay time	Sets the speed deviation detection method. Any speed deviation above the F1-10 set level (set as a percentage of the maximum output frequency) that continues for the time set in F1-11 is detected as a speed deviation. Speed deviation is the difference between actual motor speed and the reference command speed.	0.0 to 10.0	0.5 s	No	No	A	No	A	A
	PG Deviate Time									
F1-12	Number of PG gear teeth 1	Sets the number of teeth on the gears if there are gears between the PG and the motor. $\frac{\text{Input pulses from PG} \times 60}{F1-01} \times \frac{F1-13}{F1-12}$	0 to 1000	0	No	No	A	No	No	No
	PG # Gear Teeth1									
F1-13	Number of PG gear teeth 2	Sets the number of teeth on the gears if there are gears between the PG and the motor. A gear ratio of 1 will be used if either of these constants is set to 0.	0 to 1000	0	No	No	A	No	No	No
	PG # Gear Teeth2									
F1-14	PG open-circuit detection time	Used to set the PG disconnection detection time. PGO will be detected if the detection time continues beyond the set time.	0.0 to 10.0	2.0 s	No	No	A	No	A	No
	PGO Detect Time									

* The factory setting will change when the control method is changed. (Flux vector control factory settings are given.)

■ Using PG Speed Control Card

There are four types of PG Speed Control Card that can be used in V/f control with PG.

- PG-A2: A-phase (single) pulse input, compatible with open collector or complimentary outputs.
- PG-B2: A/B-phase pulse input, compatible with complimentary outputs.
- PG-D2: A-phase (single) pulse input, compatible with line drivers.
- PG-X2: A/B/Z-phase pulse input, compatible with line drivers.

There are two types of PG Speed Control Cards that can be used for flux vector control.

- PG-B2: A/B phase pulse inputs, complementary outputs
- PG-X2: A/B/Z phase pulse inputs, line driver outputs

For the connection diagram, refer to *page 2-32*.

■ Setting Number of PG Pulses

Set the number of PG (Pulse Generator/Encoder) pulses in pulses/rotation. Set the number of A-phase or B-phase pulses per 1 motor rotation in F1-01.

■ Matching PG Rotation Direction and Motor Rotation Direction

Constant F1-05 matches the PG rotation direction and the motor rotation direction. If the motor is rotating forwards, set whether it is A-phase driven or B-phase driven. Make this setting when using PG-B2 or PG-X2.

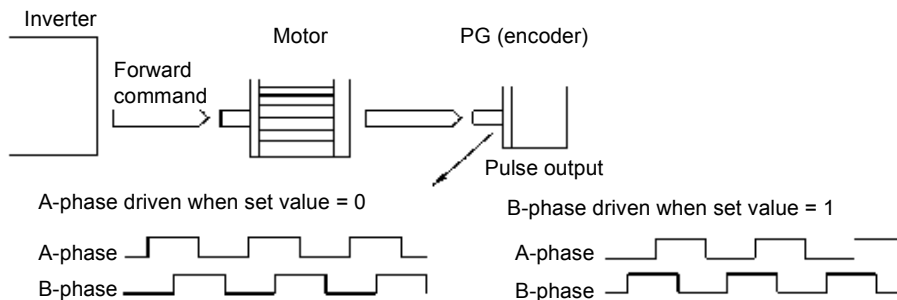

Example: Forward rotation of standard Yaskawa motor (PG used: Samtack (KK))

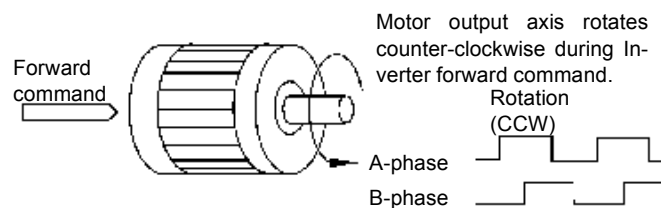

Yaskawa standard PG used is A-phase driven (CCW) when motor rotation is forward.

Fig 6.75 PG Rotation Direction Setting

Generally, PG is A-phase driven when rotation is clockwise (CW) see from the input axis. Also, motor rotation is counter-clockwise (CCW) seen from the output side when forward commands are output. Consequently, when motor rotation is forward, PG is normally A-phase driven when a load is applied, and B-phase driven when a load is not applied.

■ Setting Number of Gear Teeth Between PG and Motor

Set the number of PG gear teeth in F1-12 and F1-13. If there are gears between the motor and PG, you can operate the motor by setting the number of gear teeth.

When the number of gear teeth has been set, the number of motor rotations within the Inverter is calculated using the following formula.

No. of motor rotations (min^{-1}) = No. of input pulses from PC \times 60 / F1-01 \times F1-13 (No. of gear teeth on load side) / F1-12 (No. of gear teeth on motor side)

■ Matching Motor Speed During Acceleration and Deceleration to Frequency Reference

You can select whether to enable or disable integral operation during acceleration and deceleration when using flux vector control.

To match the motor speed as closely as possible to the frequency reference even during acceleration and deceleration, set F1-07 to 1.



If F1-01 is set to 1, overshoot or undershoot may occur easily immediately after acceleration and deceleration. To minimize the possibility of overshoot or undershoot occurring, set F1-01 to 0.

■ Setting PG Pulse Monitor Output Dividing Ratio

This function is enabled only when using PG speed control card PG-B2. Set the dividing ratio for the PG pulse monitor output. The set value is expressed as n for the higher place digit, and m for the lower place 2 digits. The dividing ratio is calculated as follows:

Dividing ratio = $(1 + n)/m$ (Setting range) n: 0 or 1, m: 1 to 32

$$F1-06 = \frac{\square}{n} \frac{\square\square}{m}$$

The dividing ratio can be set within the following range: $1/32 \leq F1-06 \leq 1$. For example, if the dividing ratio is 1/2 (set value 2), half of the number of pulses from the PG are monitor outputs.

■ Detecting PG Open Circuit

Select the stopping method when PG cable disconnected is detected and the PG open circuit (PGO) detection time.

When the Inverter is operating with the frequency reference set to 1% minimum (except when operating on direct current), if the speed feedback from PG is greater than the time setting in F1-14, PGO is detected.

■ Detecting Motor Overspeed

An error is detected when the number of motor rotations exceeds the regulated limit. An overspeed (OS) is detected when a frequency that exceeds the set value in F1-08 continues for longer than the time set in F1-09. After detecting an overspeed (OS), the Inverter stops according to the setting in F1-03.

■ Detecting Speed Difference between the Motor and Speed Reference

An error is detected when the speed deviation (i.e., the difference between the designated speed and the actual motor speed) is too great. Speed deviation (DEV) is detected after a speed agreement is detected and when the speed reference and actual workpiece speed are within the setting of L4-02, if a speed deviation great than the set value in F1-10 continues for longer than the time set in F1-11. After a speed deviation is detected, the Inverter stops according to the setting in F1-04.

◆ Using Digital Output Cards

There are two types of Inverter digital output cards:

- DO-02C
Relay contact output (DPDT contact)
- DO-08
6 photocoupler output channels (shared commons)
2 (independent) relay contact output channels (NC contact)

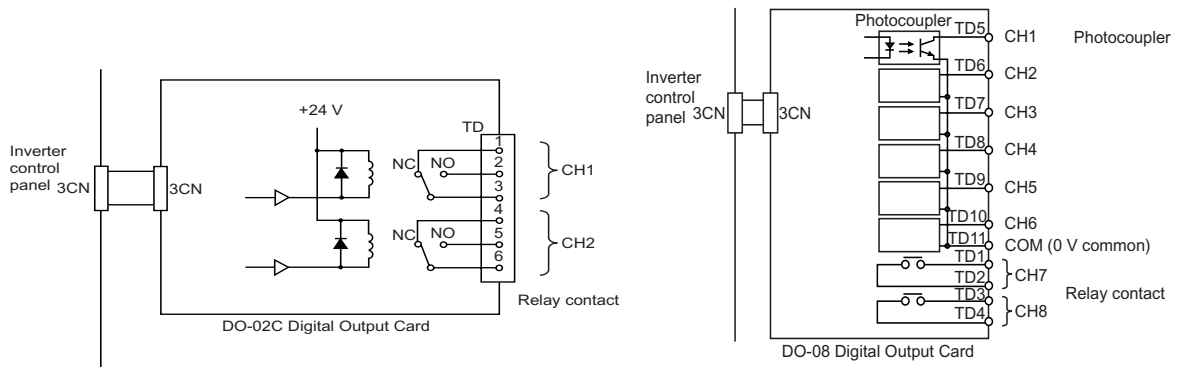

Fig 6.76 Digital Output Cards

■ Related Constants

Constant Number	Name	Description	Setting Range	Factory Setting	Change during Operation	Control Methods				
	Display					V/f	V/f with PG	Open Loop Vector 1	Flux Vector	Open Loop Vector 2
F5-01	Channel 1 output selection	Effective when a Digital Output Card (DO-02 or DO-08) is used. Set the number of the multi-function output to be output.	0 to 37	0	No	A	A	A	A	A
	DO Ch1 Select									
F5-02	Channel 2 output selection	Effective when a Digital Output Card (DO-02 or DO-08) is used. Set the number of the multi-function output to be output.	0 to 37	1	No	A	A	A	A	A
	DO Ch2 Select									
F5-03	Channel 3 output selection	Effective when a DO-08 Digital Output Card is used. Set the number of the multi-function output to be output.	0 to 37	2	No	A	A	A	A	A
	DO Ch3 Select									
F5-04	Channel 4 output selection	Effective when a DO-08 Digital Output Card is used. Set the number of the multi-function output to be output.	0 to 37	4	No	A	A	A	A	A
	DO Ch4 Select									
F5-05	Channel 5 output selection	Effective when a DO-08 Digital Output Card is used. Set the number of the multi-function output to be output.	0 to 37	6	No	A	A	A	A	A
	DO Ch5 Select									
F5-06	Channel 6 output selection	Effective when a DO-08 Digital Output Card is used. Set the number of the multi-function output to be output.	0 to 37	37	No	A	A	A	A	A
	DO Ch6 Select									

Con- stant Number	Name	Description	Setting Range	Factory Setting	Change during Opera- tion	Control Methods				
	Display					V/f	V/f with PG	Open Loop Vector 1	Flux Vec- tor	Open Loop Vector 2
F5-07	Channel 7 out- put selection	Effective when a DO-08 Digital Output Card is used. Set the number of the multi-func- tion output to be output.	0 to 37	0F	No	A	A	A	A	A
	DO Ch7 Select									
F5-08	Channel 8 out- put selection	Effective when a DO-08 Digital Output Card is used. Set the number of the multi-func- tion output to be output.	0 to 37	0F	No	A	A	A	A	A
	DO Ch8 Select									
F5-09	DO-08 output mode selection	Effective when a DO-08 Digital Output Card is used. Set the output mode. 0: 8-channel individual outputs 1: Binary code output 2: Output according to F5-01 to F5-08 settings.	0 to 2	0	No	A	A	A	A	A
	DO-08 Selec- tion									

■Setting Output Items for the DO-02C Digital Output Card

If using DO-02C Digital Output Card, set the output items using F5-01 and F5-02.

■Setting Output Items for the DO-08 Digital Output Card

If using DO-08 Digital Output Card, select one of the following three output modes according to the setting in F5-09.

F5-09 Set to 0

Set Value	Terminal Number	Output Details
0: 8 separate outputs	TD5-TD11	Overcurrent (SC, OC, GF)
	TD6-TD11	Overvoltage (OV)
	TD7-TD11	Inverter overload (OL2)
	TD8-TD11	Fuse blown (PUF)
	TD9-TD11	Overspeed (OS)
	TD10-TD11	Inverter overheated (OH1) or motor overload (OL1)
	TD1-TD2	Zero speed detected
	TD3-TD4	Speed agreement

F5-09 Set to 1

Set Value	Terminal Number	Output Details	
1: Binary code output	TD5-TD11	bit 0	Encoded output (Refer to table below)
	TD6-TD11	bit 1	
	TD7-TD11	bit 2	
	TD8-TD11	bit 3	
	TD9-TD11	Zero speed detected	
	TD10-TD11	Speed agreement	
	TD1-TD2	Operating	
	TD3-TD4	Minor fault	

The following table shows the code outputs.

Bits 3, 2, 1, and 0	Output Details	Bits 3, 2, 1, and 0	Output Details
0000	No error	1000	External fault (EFxx)
0001	Overcurrent (SC, OC, GF)	1001	Controller error (CPFxx)
0010	Overvoltage (OV)	1010	Motor overload (OL1)
0011	Inverter overload (OL2)	1011	Not used
0100	Inverter overheated (OH, OH1)	1100	Power loss (UV1, UV2, or UV3)
0101	Overspeed (OS)	1101	Speed deviation (DEV)
0110	Fuse blown (PUF)	1110	PG open circuit (PGO)
0111	Dynamic braking resistor (RH) Injection brake transistor error (RR)	1111	Not used

F5-09 Set to 2

Output depends on the settings in F5-01 to F5-08.

◆ Using an Analog Reference Card

When using a AI-14B or A1-14U Analog Reference Card, set constant b1-01 (Reference selection) to 3 (Option Card).

AI-14B provides 3 channels of bi-polar inputs with 14-bit A/D conversion accuracy (and a sign bit). The function of each channel is determined by the setting of F2-01.

AI-14U provides 2 channels of bi-polar inputs with 14-bit A/D conversion accuracy. Channel 1 is a voltage input and channel 2 is a current input. The sum of channels 1 and 2 is a frequency input. F2-01 does not need to be set for the AI-14U.

■ Related Constants

Constant Number	Name	Description	Setting Range	Factory Setting	Change during Operation	Control Methods				
	Display					V/f	V/f with PG	Open Loop Vector 1	Flux Vector	Open Loop Vector 2
F2-01	Bi-polar or unipolar input selection	Sets the functions for channel 1 to 3 that are effective when the AI-14B Analog Reference Card is used. 0: 3-channel individual (Channel 1: terminal A1, Channel 2: terminal A2, Channel 3: terminal A3) 1: 3-channel addition (Addition values are the frequency reference) When set to 0, select 1 for b1-01. In this case the multi-function input "Option/Inverter selection" cannot be used.	0 or 1	0	No	A	A	A	A	A
	AI-14 Input Sel									

■ Setting Precautions

Always set b1-01 (Reference selection) to 1 (control circuit terminal) when using the AI-14B for three channels of independent inputs. When this is done, H1-01 to H1-10 (multi-function contact inputs) cannot be set to 2 (Option/Inverter selection).

◆ Using a Digital Reference Card

When using a DI-08 or DI-16H2 Digital Reference Card, set b1-01 (Reference selection) to 3 (Option Card).

The DI-16H2 can be used to set a frequency using a 16-bit digital reference. The DI-08 can be used to set a frequency using a 8-bit digital reference.

■ Related Constants

Constant Number	Name	Description	Setting Range	Factory Setting	Change during Operation	Control Methods				
	Display					V/f	V/f with PG	Open Loop Vector 1	Flux Vector	Open Loop Vector 2
F3-01	Digital input option	Sets the Digital Reference Card input method. 0: BCD 1% unit 1: BCD 0.1% unit 2: BCD 0.01% unit 3: BCD 1 Hz unit 4: BCD 0.1 Hz unit 5: BCD 0.01 Hz unit 6: BCD special setting (5-digit input) 7: Binary input 6 is only effective when the DI-16H2 is used. When o1-03 is set to 2 or higher, the input will be BCD, and the units will change to the o1-03 setting.	0 to 7	0	No	A	A	A	A	A
	DI Input									

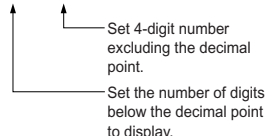
Constant Number	Name	Description	Setting Range	Factory Setting	Change during Operation	Control Methods				
	Display					V/f	V/f with PG	Open Loop Vector 1	Flux Vector	Open Loop Vector 2
o1-03	Frequency units of reference setting and monitor	Sets the units that will be set and displayed for the frequency reference and frequency monitor. 0: 0.01 Hz units 1: 0.01% units (Maximum output frequency is 100%) 2 to 39: min ⁻¹ units (Sets the motor poles.) 40 to 39999: User desired display Set the desired values for setting and display for the max. output frequency. □□□□□  Example: When the max. output frequency value is 200.0, set 12000	0 to 39999	0	No	A	A	A	A	A
	Display Scaling									

■ Selecting Input Terminal Functions for the DI-16H2 Digital Reference Card

The frequency reference from the DI-16H2 Card is determined by the setting of F3-01 and the 12/16-bit switch on the Option card. The possible settings are listed in the following table.

Terminal	Pin No.	12-bit Binary with Sign	16-bit Binary with Sign	3-digit BCD with Sign	4-digit BCD with Sign	4-digit BCD without Sign			
		F3-01 = 7 S1: 12 bit	F3-01 = 7 S1: 16 bit	F3-01 = 0 to 5 S1: 12 bit	F3-01 = 0 to 5 S1: 16 bit	F3-01 = 6 S1: 16 bit			
TC1	1	Bit 1 (2^0)	Bit 1 (2^0)	1	BDC digit 1 (0 to 9)	1	BDC digit 1 (0 to 9)	2	BDC digit 1 (2 to 9)
	2	Bit 1 (2^1)	Bit 1 (2^1)	2		2		4	
	3	Bit 1 (2^2)	Bit 1 (2^2)	4		4		8	
	4	Bit 1 (2^3)	Bit 1 (2^3)	8		8		1	
	5	Bit 1 (2^4)	Bit 1 (2^4)	1	BDC digit 2 (0 to 9)	1	BDC digit 2 (0 to 9)	2	BDC digit 2 (0 to 9)
	6	Bit 1 (2^5)	Bit 1 (2^5)	2		2		4	
	7	Bit 1 (2^6)	Bit 1 (2^6)	4		4		8	
	8	Bit 1 (2^7)	Bit 1 (2^7)	8		8		1	
	9	Bit 1 (2^8)	Bit 1 (2^8)	1	BDC digit 3 (0 to 9)	1	BDC digit 3 (0 to 9)	2	BDC digit 3 (0 to 9)
	10	Bit 1 (2^9)	Bit 1 (2^9)	2		2		4	
TC2	1	Bit 1 (2^{10})	Bit 1 (2^{10})	4		4		8	
	2	Bit 1 (2^{11})	Bit 1 (2^{11})	8		8		1	
	3	-	Bit 1 (2^{12})		-	1	BDC digit 4 (0 to 9)		
	4	-	Bit 1 (2^{13})		-	2			
	5	-	Bit 1 (2^{14})		-	4			
	6	-	Bit 1 (2^{15})		-	8			
	7	Sign signal (0: Forward, 1: Reverse)						2	BDC digit 5 (0 to 3)
	8	SET (read) signal (1: Read)							
	9	Input signal common (0 V)							
TC3	Shield wire connection terminal								

■Application Precautions

- The maximum frequency (100% speed) reference will be used when the binary input is set (setting: 6 or 7) and all bits are 1.
- Setting F3-01 to 6 is valid only when the D1-16H2 is used. Using this setting, a frequency from 0.00 to 399.8 Hz can be set in BCD. The sign bit is used as a data bit, so only positive (plus) data can be set. Also, the digit starts from 0, so the minimum setting is 0.02 Hz.

■Selecting the Input Terminal Function for a DI-08 Digital Reference Card

The frequency reference from a DI-08 Card is determined by the setting of F3-01, as shown in the following table.

Terminal	Pin No.	8-bit Binary with Sign	2-digit BCD with Sign		
		F3-01 = 7	F3-01 = 0 to 5		
TC	1	Bit 1 (2^0)	1	BDC digit 1 (0 to 9)	
	2	Bit 1 (2^1)	2		
	3	Bit 1 (2^2)	4		
	4	Bit 1 (2^3)	8		
	5	Bit 1 (2^4)	1	BDC digit 2 (0 to 15)	
	6	Bit 1 (2^5)	2		
	7	Bit 1 (2^6)	4		
	8	Bit 1 (2^7)	8		
	9	Sign signal			
	10	SET (read) signal			
	11	Reference common signal (0 V)			

■ Application Precautions

The DI-08 will not function if F3-01 is set to 6

■ Selecting the Digital Reference

The range of the digital references is determined by the combination of the settings of o1-03 and F3-01. The information monitored in U1-01 (Frequency reference) will also change.

DI-16H2 Reference Ranges

When using the DI-16H2, the following ranges can be set depending on the settings of the constants.

o1-03	F3-01	Switch S1	Reference Input Mode	Reference Setting Range	U1-01 Monitor Unit	
					o1-03 = 0	o1-03 = 1
0 or 1	0	12 bits	3-digit BCD with sign, 1%	-110 to 110%	0.01 Hz	0.01%
		16 bits	4-digit BCD with sign, 1%	-110 to 110%		
	1	12 bits	3-digit BCD with sign, 0.1%	-110.0 to 110.0%		
		16 bits	4-digit BCD with sign, 0.1%	-110.0 to 110.0%		
	2	12 bits	3-digit BCD with sign, 0.01%	-15.99 to 15.99%		
		16 bits	4-digit BCD with sign, 0.01%	-110.0 to 110.0%		
	3	12 bits	3-digit BCD with sign, 1 Hz	-400 to 400 Hz		
		16 bits	4-digit BCD with sign, 1 Hz	-400 to 400 Hz		
	4	12 bits	3-digit BCD with sign, 0.1 Hz	-159.9 to 159.9 Hz		
		16 bits	4-digit BCD with sign, 0.1 Hz	-400.0 to 400.0 Hz		
	5	12 bits	3-digit BCD with sign, 0.01 Hz	-15.99 to 15.99 Hz		
		16 bits	4-digit BCD with sign, 0.01 Hz	-159.99 to 159.99 Hz		
	6	16 bits	5-digit BCD without sign, 0.01 Hz	000.00 to 399.98 Hz		
	7	12 bits	12-bit binary with sign, 100%/4095	-4095 to 4095		
		16 bits	16-bit binary with sign, 100%/30000	-33000 to 33000		

o1-03	F3-01	Switch S1	Reference Input Mode	Reference Setting Range	U1-01 Monitor Unit	
					o1-03 = 0	o1-03 = 1
2 to 39	-	12 bits	3-digit BCD with sign, 1 rpm	-1599 to 1599 rpm	1 rpm	
		16 bits	4-digit BCD with sign, 1 rpm	-15999 to 15999 rpm	1 rpm	
40 to 39999	-	12 bits	3-digit BCD with sign, 100%/(1- to 4-digit setting of o1-03)	-4095 to 4095	5th digit of o1-03 setting: X = 0, unit: 1 X = 1, unit: 0.1 X = 2, unit: 0.01 X = 3, unit: 0.001	
	-	16 bits	4-digit BCD with sign, 100%/(1- to 4-digit setting of o1-03)	-10999 to 10999 (when o1-03 = 9999)		
10000 x = 1 to 3	-	16 bits	4-digit BCD with sign, 100%/10000	-11000 to 11000		

DI-08 Reference Ranges

When using the DI-08, the following ranges can be set depending on the settings of the constants.

F3-01	Reference Input Mode	Reference Setting Range	U1-01 Monitor Unit	
			o1-03 = 0	o1-03 = 1
0	2-digit BCD with sign, 1%	-110 to 110%	0.01 Hz	0.01%
1	2-digit BCD with sign, 0.1%	-15.9 to 15.9%		
2	2-digit BCD with sign, 0.01%	-1.59 to 1.59%		
3	2-digit BCD with sign, 1 Hz	-159 to 159 Hz		
4	2-digit BCD with sign, 0.1 Hz	-15.9 to 15.9 Hz		
5	2-digit BCD with sign, 0.01 Hz	-1.59 to 1.59 Hz		
6	-	-		
7	12-bit binary with sign, 100%/4095	-255 to 255		



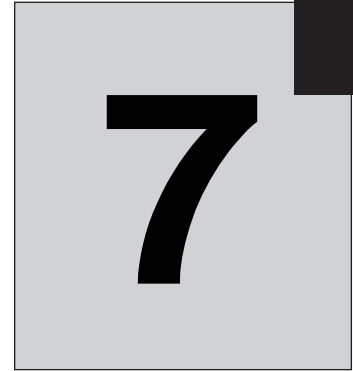

Troubleshooting

This chapter describes the fault displays and countermeasure for the Inverter and motor problems and countermeasures.

Protective and Diagnostic Functions	7-2
Troubleshooting	7-17

Protective and Diagnostic Functions

This section describes the alarm functions of the Inverter. The alarm functions include fault detection, alarm detection, operation error detection, and autotuning error detection.

◆ Fault Detection

When the Inverter detects a fault, the fault contact output operates, and the Inverter output is shut OFF causing the motor to coast to a stop. (The stopping method can be selected for some faults, and the selected stopping method will be used with these faults.) A fault code is displayed on the Digital Operator.

When a fault has occurred, refer to the following table to identify and correct the cause of the fault.

Use one of the following methods to reset the fault after restarting the Inverter:

- Set a multi-function contact input (H1-01 to H1-05) to 14 (Fault Reset) and turn ON the fault reset signal.
- Press the RESET Key on the Digital Operator.
- Turn the main circuit power supply OFF and then ON again.

Table 7.1 Fault Displays and Processing

Display	Meaning	Probable Causes	Corrective Actions
OC Over Current	Overcurrent The Inverter output current exceeded the overcurrent detection level. (200% of rated current)	<ul style="list-style-type: none"> • A short-circuit or ground fault occurred at the Inverter output. (A short or ground fault can be caused by motor burn damage, worn insulation, or a damaged cable.) • The load is too large or the acceleration/deceleration time is too short. • A special-purpose motor or motor with a capacity too large for the Inverter is being used. • A magnetic switch was switched at the Inverter output. 	Reset the fault after correcting its cause.
GF Ground Fault	Ground Fault The ground fault current at the Inverter output exceeded approximately 50% of the Inverter rated output current.	A ground fault occurred at the Inverter output. (A ground fault can be caused by motor burn damage, worn insulation, or a damaged cable.)	Reset the fault after correcting its cause.
PUF Main IGBT Fuse Blown	Fuse Blown The fuse in the main circuit is blown.	The output transistor has failed because of a short-circuit or ground fault at the Inverter output. Check whether there is a short-circuit between the following terminals. A short-circuit will damage the output transistor: B1 (⊕3) ↔ U, V, W ⊖ ↔ U, V, W	Replace the Inverter after correcting the cause.
OV DC Bus Fuse Open	Main Circuit Overvoltage The main circuit DC voltage exceeded the overvoltage detection level. 200 V class: Approx. 410 V 400 V class: Approx. 820 V	The deceleration time is too short and the regenerative energy from the motor is too large.	Increase the deceleration time or connect a braking resistor (or Braking Resistor Unit).
		The power supply voltage is too high.	Decrease the voltage so it's within specifications.

Table 7.1 Fault Displays and Processing (Continued)

Display	Meaning	Probable Causes	Corrective Actions
UV1 DC Bus Undervolt	Main Circuit Undervoltage The main circuit DC voltage is below the Undervoltage Detection Level (L2-05). 200 V class: Approx. 190 V 400 V class: Approx. 380 V	<ul style="list-style-type: none"> An open-phase occurred with the input power supply. A momentary power loss occurred. The wiring terminals for the input power supply are loose. The voltage fluctuations in the input power supply are too large. 	Reset the fault after correcting its cause.
UV2 CTL PS Undervolt	Control Power Fault The control power supply voltage dropped.	-	<ul style="list-style-type: none"> Try turning the power supply off and on. Replace the Inverter if the fault continues to occur.
UV3 MC Answer-back	Inrush Prevention Circuit Fault A fault occurred in the surge prevention circuit.	-	<ul style="list-style-type: none"> Try turning the power supply off and on. Replace the Inverter if the fault continues to occur.
PF Input Pha Loss	Main Circuit Voltage Fault The main circuit DC voltage oscillates unusually (not when regenerating). This fault is detected when L8-05 is set to "Enabled."	<ul style="list-style-type: none"> An open-phase occurred in the input power supply. A momentary power loss occurred. The wiring terminals for the input power supply are loose. The voltage fluctuations in the input power supply are too large. The voltage balance between phases is bad. 	Reset the fault after correcting its cause.
LF Output Pha Loss	Output Open-phase An open-phase occurred at the Inverter output. This fault is detected when L8-07 is set to "Enabled."	<ul style="list-style-type: none"> There is a broken wire in the output cable. There is a broken wire in the motor winding. The output terminals are loose. 	Reset the fault after correcting its cause.
		The motor being used has a capacity less than 5% of the Inverter's maximum motor capacity.	Check the motor and Inverter capacity.
OH (OH1) Heatsnk Overtemp (Heatsnk MAX Temp)	Cooling Fin Overheating The temperature of the Inverter's cooling fins exceeded the setting in L8-02 or 105°C.	The ambient temperature is too high.	Install a cooling unit.
		There is a heat source nearby.	Remove the heat source.
		The Inverter's cooling fan has stopped.	Replace the cooling fan. (Contact our sales representative.)
Inverter's Cooling Fan Stopped (18.5 kW or higher)	The Inverter's cooling fan has stopped.		
OH3 Motor Overheat 1	Motor Overheating Alarm The Inverter will stop or will continue to operate according to the setting of L1-03.	The motor has overheated.	Check the size of the load and the length of the acceleration, deceleration, and cycle times.
			Check the V/f characteristics.
			Check the Motor Rated Current (E2-01).
OH4 Motor Overheat 2	Motor Overheating Fault The Inverter will stop according to the setting of L1-04.	The motor has overheated.	Check the size of the load and the length of the acceleration, deceleration, and cycle times.
			Check the V/f characteristics.
			Check the Motor Rated Current (E2-01).

Table 7.1 Fault Displays and Processing (Continued)

Display	Meaning	Probable Causes	Corrective Actions
RH DynBrk Resistor	Installed Braking Resistor Overheating Braking resistor protection function set in L8-01 has operated.	The deceleration time is too short and the regenerative energy from the motor is too large.	<ul style="list-style-type: none"> Reduce the load, increase the deceleration time, or reduce the motor speed. Change to a Braking Resistor Unit.
RR DynBrk Transistr	Internal Braking Transistor Fault The braking transistor is not operating properly.	-	<ul style="list-style-type: none"> Try turning the power supply off and on. Replace the Inverter if the fault continues to occur.
OL1 Motor Overloaded	Motor Overload The motor overload protection function has operated based on the internal electronic thermal value.	The load is too heavy. The acceleration time, deceleration time, and cycle time are too short.	Check the size of the load and the length of the acceleration, deceleration, and cycle times.
		The V/f characteristics voltage is too high.	Check the V/f characteristics.
		The Motor Rated Current (E2-01) is incorrect.	Check the Motor Rated Current (E2-01).
OL2 Inv Overloaded	Inverter Overload The Inverter overload protection function has operated based on the internal electronic thermal value.	The load is too heavy. The acceleration time, deceleration time and cycle time are too short.	Check the size of the load and the length of the acceleration, deceleration, and cycle times.
		The V/f characteristics voltage is too high.	Check the V/f characteristics.
		The Inverter capacity is too low.	Replace the Inverter with one that has a larger capacity.
OL3 Overtorque Det 1	Overtorque Detected 1 There has been a current greater than the setting in L6-02 for longer than the setting in L6-03.	-	<ul style="list-style-type: none"> Make sure that the settings in L6-02 and L6-03 are appropriate. Check the mechanical system and correct the cause of the overtorque.
OL4 Overtorque Det 2	Overtorque Detected 2 There has been a current greater than the setting in L6-05 for longer than the setting in L6-06.	-	<ul style="list-style-type: none"> Make sure that the current setting in L6-05 and time setting in L6-06 are appropriate. Check the mechanical system and correct the cause of the overtorque.
OL7 HSB-OL	High-slip Braking OL The output frequency did not change for longer than the time set in N3-04.	The inertia returned to the load is too large.	<ul style="list-style-type: none"> Make sure the load is an inertial load. Set the system so that the deceleration time that does not produce 0 V is 120 s or less.
UL3 Undertorq Det 1	Undertorque Detected 1 There has been a current less than the setting in L6-02 for longer than the setting in L6-03.	-	<ul style="list-style-type: none"> Make sure that the settings in L6-02 and L6-03 are appropriate. Check the mechanical system and correct the cause of the overtorque.

Table 7.1 Fault Displays and Processing (Continued)

Display	Meaning	Probable Causes	Corrective Actions
UL4 Undertorq Det 2	Undertorque Detected 2 There has been a current less than the setting in L6-05 for longer than the setting in L6-06.	-	<ul style="list-style-type: none"> • Make sure that the current setting in L6-05 and time setting in L6-06 are appropriate. • Check the mechanical system and correct the cause of the overtorque.
OS Overspeed Det	Overspeed The speed has been greater than the setting in F1-08 for longer than the setting in F1-09.	Overshooting/Undershooting are occurring.	Adjust the gain again.
		The reference speed is too high.	Check the reference circuit and reference gain.
		The settings in F1-08 and F1-09 aren't appropriate.	Check the settings in F1-08 and F1-09.
PGO PG Open	PG Disconnection Detected PG pulses were input when the Inverter was outputting a frequency.	There is a break in the PG wiring.	Fix the broken/disconnected wiring.
		The PG is wired incorrectly.	Fix the wiring.
		Power isn't being supplied to the PG.	Supply power to the PG properly.
		-	Check for open circuit when using brake (motor).
DEV Speed Deviation	Excessive Speed Deviation The speed deviation has been greater than the setting in F1-10 for longer than the setting in F1-11.	The load is too heavy.	Reduce the load.
		The acceleration time and deceleration time are too short.	Lengthen the acceleration time and deceleration time.
		The load is locked.	Check the mechanical system.
		The settings in F1-10 and F1-11 aren't appropriate.	Check the settings in F1-10 and F1-11.
		-	Check for open circuit when using brake (motor).
CF Out of Control	Control Fault The torque limit was reached continuously for 3 seconds or longer during a deceleration stop during open-loop vector control 1.	Motor constant settings are not correct.	<ul style="list-style-type: none"> • Check the motor constants. • Perform autotuning.
	An error occurred in the speed estimation calculation for open-loop vector control 2.	Motor constant settings are not correct. Run command was received when the motor was coasting.	<ul style="list-style-type: none"> • Perform autotuning. • Input the run command after the motor stops. • Set b3-01 (Speed search selection) to 1 or 3 (speed search enabled at startup). • Refer to <i>Precautions When Using Open-loop Vector Control 2</i> on page 10-4.
FBL Feedback Loss	PID Feedback Reference Lost A PID feedback reference loss was detected (b5-12 = 2) and the PID feedback input was less than b5-13 (PID feedback loss detection level) for longer than the time set in b5-14 (PID feedback loss detection time).	-	-

Table 7.1 Fault Displays and Processing (Continued)

Display	Meaning	Probable Causes	Corrective Actions
EF0 Opt External Flt	External fault input from Communications Option Card	-	Check the Communications Option Card and communications signals.
EF3 Ext Fault S3	External fault (Input terminal 3)	An "external fault" was input from a multi-function input terminal.	<ul style="list-style-type: none"> • Reset external fault inputs to the multi-function inputs. • Remove the cause of the external fault.
EF4 Ext Fault S4	External fault (Input terminal 4)		
EF5 Ext Fault S5	External fault (Input terminal 5)		
EF6 Ext Fault S6	External fault (Input terminal 6)		
EF7 Ext Fault S7	External fault (Input terminal 7)		
EF8 Ext Fault S8	External fault (Input terminal 8)		
EF9 Ext Fault S9	External fault (Input terminal 9)		
EF10 Ext Fault S10	External fault (Input terminal 10)		
EF11 Ext Fault S11	External fault (Input terminal 11)		
EF12 Ext Fault S12	External fault (Input terminal 12)		
SVE Zero Servo Fault	Zero Servo Fault The rotation position moved during zero servo operation.	The torque limit is too small.	Increase the limit.
		The load torque is too large.	Reduce the load torque.
		-	Check for signal noise.
OPR Oper Disconnect	Digital Operator Connection Fault The connection to the Digital Operator was broken during operation for a RUN command from the Digital Operator.	-	Check the connection to the Digital Operator.
CE Memobus Com Err	MEMOBUS Communications Error A normal reception was not possible for 2 s or longer after control data was received once.	-	Check the communications devices and communications signals.

Table 7.1 Fault Displays and Processing (Continued)

Display	Meaning	Probable Causes	Corrective Actions
BUS Option Com Err	Option Communications Error A communications error was detected during a run command or while setting a frequency reference from a Communications Option Card.	-	Check the communications devices and communications signals.
E-15 SI-F/G Com Err	SI-F/G Communications Error Detected A communications error was detected when a run command or frequency reference was set from an Option Card and continuous operation was set for the E-15 operation selection.	-	Check the communications signals.
E-10 SI-F/G CPU down	SI-F/G Option Card CPU Failure SI-F/G Option Card operation failed.	Digital Operator connection is faulty.	Disconnect and then reconnect the Digital Operator.
		Inverter control circuit is faulty.	Replace the Inverter.
CPF00 CPF	Digital Operator Communications Error 1 Communications with the Digital Operator were not established within 5 seconds after the power was turned on.	The Digital Operator's connector isn't connected properly.	Disconnect the Digital Operator and then connect it again.
		The Inverter's control circuits are faulty.	Replace the Inverter.
	CPU External RAM Fault	-	Try turning the power supply off and on again.
CPF01 CPF01	Digital Operator Communications Error 2 After communications were established, there was a communications error with the Digital Operator for more than 2 seconds.	The Digital Operator isn't connected properly.	Disconnect the Digital Operator and then connect it again.
		The Inverter's control circuits are faulty.	Replace the Inverter.
CPF02 BB Circuit Err	Baseblock circuit error	-	Try turning the power supply off and on again.
		The control circuit is damaged.	Replace the Inverter.
CPF03 EEPROM Error	EEPROM error	-	Try turning the power supply off and on again.
		The control circuit is damaged.	Replace the Inverter.
CPF04 Internal A/D Err	CPU internal A/D converter error	-	Try turning the power supply off and on again.
		The control circuit is damaged.	Replace the Inverter.
CPF05 External A/D Err	CPU internal A/D converter error	-	Try turning the power supply off and on again.
		The control circuit is damaged.	Replace the Inverter.
CPF06 Option error	Option Card connection error	The Option Card is not connected properly.	Turn off the power and insert the Card again.
		The Inverter or Option Card is faulty.	Replace the Option Card or the Inverter.

Table 7.1 Fault Displays and Processing (Continued)

Display	Meaning	Probable Causes	Corrective Actions
CPF07 RAM-Err	ASIC internal RAM fault	-	Try turning the power supply off and on again.
		The control circuit is damaged.	Replace the Inverter.
CPF08 WAT-Err	Watchdog timer fault	-	Try turning the power supply off and on again.
		The control circuit is damaged.	Replace the Inverter.
CPF09 CPU-Err	CPU-ASIC mutual diagnosis fault	-	Try turning the power supply off and on again.
		The control circuit is damaged.	Replace the Inverter.
CPF10 ASIC-Err	ASIC version fault	The Inverter control circuit is faulty	Replace the Inverter.
CPF20 Option A/D error	Communications Option Card A/D converter error	The Option Card is not connected properly.	Turn off the power and insert the Card again.
		The Option Card's A/D converter is faulty.	Replace the Communications Option Card.
CPF21 Option CPU down	Communications Option Card self diagnostic error	Communications Option Card fault.	Replace the Option Card.
CPF22 Option Type Err	Communications Option Card model code error		
CPF23 Option DPRAM Err	Communications Option Card DPRAM error		

◆ Alarm Detection

Alarms are detected as a type of Inverter protection function that do not operate the fault contact output. The system will automatically returned to its original status once the cause of the alarm has been removed.

The Digital Operator display flashes and the alarm is output from the multi-function outputs (H2-01 to H2-03).

When an alarm occurs, take appropriate countermeasures according to the table below.

Table 7.2 Alarm Displays and Processing

Display	Meaning	Probable causes	Corrective Actions
EF (blinking) External Fault	Forward/Reverse Run Commands Input Together Both the forward and reverse run commands have been ON for more than 0.5 s.	-	Check the sequence of the forward and reverse run commands. Since the rotational direction is unknown, the motor will be decelerated to a stop when this minor fault occurs.
UV (blinking) DC Bus Under- voltage	Main Circuit Undervoltage The following conditions occurred when there was no Run signal. <ul style="list-style-type: none"> The main circuit DC voltage was below the Undervoltage Detection Level Setting (L2-05). The surge current limiting contactor opened. The control power supply voltage when below the CUV level. 	See causes for UV1, UV2, and UV3 faults in the previous table.	See corrective actions for UV1, UV2, and UV3 faults in the previous table.
OV (blinking) DC Bus Overvolt	Main Circuit Overvoltage The main circuit DC voltage exceeded the overvoltage detection level. 200 V class: Approx. 400 V 400 V class: Approx. 800 V	The power supply voltage is too high.	Decrease the voltage so it's within specifications.
OH (blinking) Heat- sink Over- temp	Cooling Fin Overheating The temperature of the Inverter's cooling fins exceeded the setting in L8-02.	The ambient temperature is too high.	Install a cooling unit.
		There is a heat source nearby.	Remove the heat source
		The Inverter cooling fan has stopped.	Replace the cooling fan. (Contact your Yaskawa representative.)
OH2 (blinking) Over Heat 2	Inverter Overheating Pre-alarm An OH2 alarm signal (Inverter overheating alarm signal) was input from a multi-function input terminal (S3 to S7).	-	Clear the multi-function input terminal's overheating alarm input.
OH3 (blinking) Motor Over- heat 1	Motor overheating E was set for H3-09 and the motor temperature thermistor input exceeded the alarm detection level.	The motor has overheated.	Check the size of the load and the length of the acceleration, deceleration, and cycle times.
			Check the V/f characteristics.
			Check the motor temperature input on terminals A1 and A2.
OL3 (blinking) Over- torque Det 1	Overtorque 1 There has been a current greater than the setting in L6-02 for longer than the setting in L6-03.	-	<ul style="list-style-type: none"> Make sure that the settings in L6-02 and L6-03 are appropriate. Check the mechanical system and correct the cause of the overtorque.

Table 7.2 Alarm Displays and Processing (Continued)

Display	Meaning	Probable causes	Corrective Actions
OL4 (blinking) Over- torque Det 2	Overtorque 2 There has been a current greater than the setting in L6-05 for longer than the setting in L6-06.	-	<ul style="list-style-type: none"> • Make sure that the current setting in L6-05 and time setting in L6-06 are appropriate. • Check the mechanical system and correct the cause of the overtorque.
UL3 (blinking) Under- torq Det 1	Undertorque 1 There has been a current less than the setting in L6-02 for longer than the setting in L6-03.	-	<ul style="list-style-type: none"> • Make sure that the settings in L6-02 and L6-03 are appropriate. • Check the mechanical system and correct the cause of the overtorque.
UL4 (blinking) Under- torq Det 2	Undertorque 2 There has been a current less than the setting in L6-05 for longer than the setting in L6-06.	-	<ul style="list-style-type: none"> • Make sure that the current setting in L6-05 and time setting in L6-06 are appropriate. • Check the mechanical system and correct the cause of the overtorque.
OS (blinking) Over- speed Det	Overspeed The speed has been greater than the setting in F1-08 for longer than the setting in F1-09.	Overshooting/undershooting are occurring.	Adjust the gain again.
		The reference speed is too high.	Check the reference circuit and reference gain.
		The settings in F1-08 and F1-09 aren't appropriate.	Check the settings in F1-08 and F1-09.
PGO (blinking) PG Open	The PG is disconnected The Inverter is outputting a frequency, but PG pulses aren't being input.	There is a break in the PG wiring.	Fix the broken/disconnected wiring.
		The PG is wired incorrectly.	Fix the wiring.
		Power isn't being supplied to the PG.	Supply power to the PG properly.
DEV (blinking) Speed Devia- tion	Excessive Speed Deviation The speed deviation has been greater than the setting in F1-10 for longer than the setting in F1-11.	The load is too large.	Reduce the load.
		The acceleration time and deceleration time are too short.	Lengthen the acceleration time and deceleration time.
		The load is locked.	Check the mechanical system.
		The settings in F1-10 and F1-11 aren't appropriate.	Check the settings in F1-10 and F1-11.
EF0 Opt External Flt	External fault detected for Communications Card other than SI-K2 Continuing operation was specified for EF0 (F6-03 = 3) and an external fault was input from the Option Card.	-	Remove the cause of the external fault.

Table 7.2 Alarm Displays and Processing (Continued)

Display	Meaning	Probable causes	Corrective Actions		
EF3 (blinking) Ext Fault S3	External fault (Input terminal S3)	An external fault was input from a multi-function input terminal (S3 to S7).	<ul style="list-style-type: none"> • Reset external fault inputs to the multi-function inputs. • Remove the cause of the external fault. 		
EF4 (blinking) Ext Fault S4	External fault (Input terminal S4)				
EF5 (blinking) Ext Fault S5	External fault (Input terminal S5)				
EF6 (blinking) Ext Fault S6	External fault (Input terminal S6)				
EF7 (blinking) Ext Fault S7	External fault (Input terminal S7)				
EF8 (blinking) Ext Fault S8	External fault (Input terminal S8)				
EF9 (blinking) Ext Fault S9	External fault (Input terminal S9)				
EF10 (blinking) Ext Fault S10	External fault (Input terminal S10)				
EF11 (blinking) Ext Fault S11	External fault (Input terminal S11)				
EF12 (blinking) Ext Fault S12	External fault (Input terminal S12)				
FBL (blinking) Feed- back Loss	PID Feedback Reference Lost A PID feedback reference loss was detected (b5-12 = 2) and the PID feedback input was less than b5-13 (PID feedback loss detection level) for longer than the time set in b5-14 (PID feedback loss detection time).			-	-
CE (blinking) MEMO- BUS Com Err	MEMOBUS Communications Error Normal reception was not possible for 2 s or longer after received control data.			-	Check the communications devices and signals.

Table 7.2 Alarm Displays and Processing (Continued)

Display	Meaning	Probable causes	Corrective Actions
BUS (blinking) Option Com Err	Option Card Communications Error A communications error occurred in a mode where the run command or a frequency reference is set from an Communications Option Card.	-	Check the communications devices and signals.
CALL (blinking) Com Call	Communications on Standby Control data was not normally received when power was turned ON.	-	Check the communications devices and signals.
E-15 SI-F/G Com Err	SI-F/G Communications Error Detected A communications error was detected when a run command or frequency reference was set from an Option Card and continuous operation was set for the E-15 operation selection.	-	Check the communications signals.

◆ Operation Errors

An operation error will occur if there is an invalid setting or a contradiction between two constant settings. It won't be possible to start the Inverter until the constants have been set correctly. (The alarm output and fault contact outputs will not operate either.)

When an operation error has occurred, refer to the following table to identify and correct the cause of the errors.

Table 7.3 Operation Error Displays and Incorrect Settings

Display	Meaning	Incorrect settings
OPE01 kVA Selection	Incorrect Inverter capacity setting	The Inverter capacity setting doesn't match the Unit. (Contact your Yaskawa representative.)
OPE02 Limit	Constant setting range error	The constant setting is outside of the valid setting range. When this error is displayed, press the ENTER Key to display U1-34 (OPE fault constant).
OPE03 Terminal	Multi-function input selection error	One of the following errors has been made in the multi-function input (H1-01 to H1-10) settings: <ul style="list-style-type: none"> • The same setting has been selected for two or more multi-function inputs. • An up or down command was selected independently. (They must be used together.) • The up/down commands (10 and 11) and Accel/Decel Ramp Hold (A) were selected at the same time. • Speed Search 1 (61, maximum output frequency) and Speed Search 2 (62, set frequency) were selected at the same time. • The up/down commands (10 and 11) were selected while PID Control Mode Selection (b5-01) was enabled. • Positive and negative speed commands have not been set at the same time. • The emergency stop command NO and NC have been set at the same time.
OPE05 Sequence Select	Option Card selection error	The Option Card was selected as the frequency reference source by setting b1-01 to 3, but an Option Card isn't connected (C option).
OPE06 PG Opt Missing	Control method selection error	V/f control with PG feedback was selected by setting A1-02 to 1, but a PG Speed Control Card isn't connected.
OPE07 Analog Selection	Multi-function analog input selection error	The same setting has been selected for the analog input selection and the PID function selection. <ul style="list-style-type: none"> • H3-09 = B and H6-01 = 1 • H3-09 = C and H6-01 = 2 b1-01 (Reference Selection) is set to 4 (pulse input) and H6-01 (Pulse Train Input Function Selection) is set to a value other than 0 (frequency reference).
OPE08	Constant selection error	A setting has been made that is not required in the current control method. Ex.: A function used only with open-loop vector control was selected for V/f control. When this error is displayed, press the ENTER Key to display U1-34 (OPE fault constant).
OPE09	PID control selection error	The following settings have been made at the same time. <ul style="list-style-type: none"> • b5-01 (PID Control Mode Selection) has been set to a value other than 0. • b5-15 (PID Sleep Function Operation Level) has been set to a value other than 0. • b1-03 (Stopping Method Selection) has been set to 2 or 3.
OPE10 V/f Ptrn Setting	V/f data setting error	Constants E1-04, E1-06, E1-07, and E1-09 do not satisfy the following conditions: <ul style="list-style-type: none"> • E1-04 (FMAX) \geq E1-06 (FA) $>$ E1-07 (FB) \geq E1-09 (FMIN) • E3-02 (FMAX) \geq E3-04 (FA) $>$ E3-05 (FB) \geq E3-07 (FMIN)

Table 7.3 Operation Error Displays and Incorrect Settings (Continued)

Display	Meaning	Incorrect settings
OPE11 Carr Freq/ On-Delay	Constant setting error	<p>One of the following constant setting errors exists.</p> <ul style="list-style-type: none"> • C6-05 (Carrier Frequency Gain) > 6, the Carrier Frequency Lower Limit (C6-04) > the Carrier Frequency Gain(C6-05) • Upper/lower limit error in C6-03 to 05. • C6-01 is 0 and C6-02 is 2 to E. • C6-01 is 1 and C6-02 is 7 to E.
ERR EEPROM R/W Err	EEPROM write error	<p>A verification error occurred when writing EEPROM.</p> <ul style="list-style-type: none"> • Try turning the power supply off and on again. • Try setting the constants again.

◆ Errors During Autotuning

The errors that can occur during autotuning are given in the following table. If an error is detected, the motor will coast to a stop and an error code will be displayed on the Digital Operator. The error contact output and alarm output will not function.

Table 7.4 Errors During Autotuning

Display	Meaning	Probable causes	Corrective Actions
Data Invalid	Motor data error	There is an error in the data input for autotuning. There is an error in the relationship between the motor output and the motor rated current. There is an error between the no-load current setting and the input motor rated current (when autotuning for only line-to-line resistance is performed for vector control).	<ul style="list-style-type: none"> • Check the input data. • Check the capacity of the Inverter and motor. • Check the motor rated current and no-load current.
Minor Fault	Alarm	A minor fault occurred during autotuning (xxx).	<ul style="list-style-type: none"> • Check the input data. • Check wiring and the machine. • Check the load.
STOP key	STOP key input	The STOP Key was pressed to cancel autotuning.	
Resistance	Line-to-line resistance error	Autotuning was not completed in the specified time. The results of autotuning has exceeded the setting range for a user constant.	<ul style="list-style-type: none"> • Check the input data. • Check motor wiring. • If the motor is connected to the machine, disconnect it.
No-Load Current	No-load current error		
Rated Slip	Rated slip error		
Accelerate	Acceleration error (detected only for rotational autotuning)	The motor did not accelerate in the specified time.	<ul style="list-style-type: none"> • Increase C1-01 (Acceleration Time 1). • Increase L7-01 and L7-02 (Reverse Torque Limits) if they are low. • If the motor is connected to the machine, disconnect it.
Motor Speed	Motor speed error (detected only for rotational autotuning)	The torque reference was too high (100%) during acceleration (for open-loop vector control only).	<ul style="list-style-type: none"> • If the motor is connected to the machine, disconnect it. • Increase C1-01 (Acceleration Time 1). • Check the input data (particularly the number of PG pulses and the number of motor poles).
I-det. Circuit	Current detection error	The current flow exceeded the motor rated current.	Check the current detection circuit, motor wiring, current detector, and installation methods.
		The detected current sign was the opposite of what it should be.	
		There is a phase fault for U, V, or W.	
Leak Inductance	Leakage inductance error	Autotuning was not completed in the specified time.	Check motor wiring.
V/f Over Setting	V/f settings excessive*	The torque reference exceeded 100% and the no-load torque exceeded 70% during autotuning.	<ul style="list-style-type: none"> • Check and correct the settings. • Disconnect the load from the motor.

Table 7.4 Errors During Autotuning (Continued)

Display	Meaning	Probable causes	Corrective Actions
Saturation	Motor core saturation error (detected only for rotational autotuning)*	The results of autotuning has exceeded the setting range for a user constant so a temporary setting was made for the motor core saturation coefficient.	<ul style="list-style-type: none"> • Check the input data. • Check motor wiring. • If the motor is connected to the machine, disconnect it.
Rated FLA Alm	Rated current setting alarm*	The rated current is set high.	Check the input data (particularly the motor output current and motor rated current).

* Displayed after autotuning has been completed.

◆ Errors when Using the Digital Operator Copy Function

The errors that can occur when using the copy function from the Digital Operator are given in the following table. An error code will be displayed on the Digital Operator. If a Digital Operator key is pressed when an error code is being displayed, the display will be cleared and 03-01 will be displayed. The error contact output and alarm output will not function.

Table 7.5 Errors during Copy Function

Function	Display	Meaning	Probable causes	Corrective Actions
Read	PRE READ IMPOSSIBLE	Digital Operator write-protected	o3-01 was set to 1 to write a constant when the Digital Operator was write-protected (o3-02 = 0).	Set o3-02 to 1 to enable writing constants with the Digital Operator.
	IFE READ DATA ERROR	Illegal read data	The read data length does not agree. The write data is incorrect.	Repeat the read. Check the Digital Operator cable. Replace the Digital Operator.
	RDE DATA ERROR	Illegal write status	An attempted write of a constant to EEPROM on the Digital Writer failed.	A low Inverter voltage has been detected. Repeat the read. Replace the Digital Operator.
Copy	CPE ID UNMATCH	ID not matched	The Inverter product code or software number is different.	Use the copy function for the same product code and software number.
	VAE INV. KVA UNMATCH	Inverter capacity matched	The capacity of the Inverter being copied and the capacity in the Digital Operator are different.	Use the copy function for the same Inverter capacity.
	CRE CONTROL UNMATCH	Control method matched	The control method of the Inverter being copied and the control method in the Digital Operator are different.	Use the copy function for the same control method.
	CYE COPY ERROR	Verify error	The constant written to the Inverter was compared with the constant in the Digital Operator and they were different.	Retry the copy.
	CSE SUM CHECK ERROR	Checksum error	The checksum in the Inverter constant area was compared with the checksum in the Digital Operator constant area and they were different.	Retry the copy.
Verify	VYE VERIFY ERROR	Verify error	The Digital Operator and Inverter settings do not agree.	Retry the copy and verify again.

Troubleshooting

Due to constant setting errors, faulty wiring, and so on, the Inverter and motor may not operate as expected when the system is started up. If that should occur, use this section as a reference and apply the appropriate measures.

If the contents of the fault are displayed, refer to *Protective and Diagnostic Functions*.

◆ If Constant Constants Cannot Be Set

Use the following information if an Inverter constant cannot be set.

■ The display does not change when the Increment and Decrement Keys are pressed.

The following causes are possible.

The Inverter is operating (drive mode).

There are some constants that cannot be set during operation. Turn the Inverter off and then make the settings.

Constant write enable is input.

This occurs when “constant write enable” (set value: 1B) is set for a multi-function input terminal (H1-01 to H1-10). If the constant write enable input is OFF, the constants cannot be changed. Turn it ON and then set the constants.

Passwords do not match. (Only when a password is set.)

If the constant A1-04 (Password) and A1-05 (Password Setting) numbers are different, the constants for the initialize mode cannot be changed. Reset the password.

If you cannot remember the password, display A1-05 (Password Setting) by pressing the Reset/Select Key and the Menu Key simultaneously while in the A1-04 display. Then reset the password. (Input the reset password in constant A1-04.)

■ OPE01 through OPE11 is displayed.

The set value for the constant is wrong. Refer to *Operation Errors* in this chapter and correct the setting.

■ CPF00 or CPF01 is displayed.

This is a Digital Operator communications error. The connection between the Digital Operator and the Inverter may be faulty. Remove the Digital Operator and then re-install it.

◆ If the Motor Does Not Operate

Use the following information if the motor does not operate.

■ The motor does not operate when the RUN Key on the Digital Operator is pressed.

The following causes are possible.



If the Inverter is not in drive mode, it will remain in ready status and will not start. Press the Menu Key to display the drive mode, and enter the drive mode by pressing the DATA/ENTER Key. “-Rdy-” will be displayed when drive mode is entered.

The operation method setting is wrong.

If constant b1-02 (Operation Method Selection) is set to 1 (control circuit terminal), the motor will not operate when the Run Key is pressed. Either press the LOCAL/REMOTE Key* to switch to Digital Operator operation or set b1-02 to 0 (Digital Operator).



INFO

The LOCAL/REMOTE Key is enabled by setting o2-01 to 1 and disabled by setting o2-01 to 2. It is enabled when the drive mode is entered.

The frequency reference is too low.

If the frequency reference is set below the frequency set in E1-09 (Minimum Output Frequency), the Inverter will not operate.

Raise the frequency reference to at least the minimum output frequency.

There is a multi-function analog input setting error.

If multi-function analog input H3-09 is set to 1 (frequency gain), and if no voltage (current) is input, then the frequency reference will be zero. Check to be sure that the set value and analog input value are correct.

■ The motor does not operate when an external operation signal is input.

The following causes are possible.

The Inverter is not in drive mode.

If the Inverter is not in drive mode, it will remain in ready status and will not start. Press the MENU Key to display the drive mode, and enter the drive mode by pressing the DATA/ENTER Key. “-Rdy-” will be displayed when drive mode is entered.

The operation method selection is wrong.

If constant b1-02 (reference selection) is set to 0 (Digital Operator), the motor will not operate when an external operation signal is input. Set b1-02 to 1 (control circuit terminal) and try again.

Similarly, the motor will also not operate if the LOCAL/REMOTE Key has been pressed to switch to Digital Operator operation. In that case press the LOCAL/REMOTE Key* again to return to the original setting.



INFO

The LOCAL/REMOTE Key is enabled by setting o2-01 to 1 and disabled by setting o2-01 to 2. It is enabled when the drive mode is entered.

A 3-wire sequence is in effect.

The input method for a 3-wire sequence is different than when operating by forward/stop and reverse/stop (2-wire sequence). When 3-wire sequence is set, the motor will not operate even when an input terminal suitable for forward run/stop and reverse run/stop is turned ON.

When using a 3-wire sequence, refer to the timing chart and input the proper signals.

When using a 2-wire sequence, set the multi-function input terminal (H1-01 through H1-10, terminals S3 to S11) to a value other than 0.

The frequency reference is too low.

If the frequency reference is set below the frequency set in E1-09 (Minimum Output Frequency), the Inverter will not operate. Raise the frequency reference to at least the minimum output frequency.

There is a multi-function analog input setting error.

If multi-function analog inputs H3-05 (Multi-function Analog Input Terminal A3 Selection) and H3-09 (Multi-function Analog Input Terminal A2 Selection) are set to 1 (frequency gain), and if no voltage (current) is input, then the frequency reference will be zero. Check to be sure that the set value and analog input value are correct.

■ The motor stops during acceleration or when a load is connected.

The load may be too heavy. The Inverter has a stall prevention function and an automatic torque boost function, but the motor responsiveness limit may be exceeded if acceleration is too rapid or if the load is too heavy. Lengthen the acceleration time or reduce the load. Also consider increasing the motor capacity.

■ The motor only rotates in one direction.

“Reverse run prohibited” is selected. If b1-04 (Prohibition of Reverse Operation) is set to 1 (reverse run prohibited), the Inverter will not receive reverse run commands. To use both forward and reverse operation, set b1-04 to 0.

◆ If the Direction of the Motor Rotation is Reversed

If the motor operates in the wrong direction, the motor output wiring is faulty. When the Inverter T1(U), T2(V), and T3(W) are properly connected to the motor T1(U), T2(V), and T3(W), the motor operates in a forward direction when a forward run command is executed. The forward direction depends on the manufacturer and the motor type, so be sure to check the specifications.

The direction of rotation can be reversed by switching two wires among U, V, and W.

◆ If the Motor Does Not Put Out Torque or If Acceleration is Slow

Use the following information if the motor does not output torque or if acceleration is too slow.

■ The torque limit has been reached.

When a torque limit has been set in constants L7-01 to L7-04, no torque will be output beyond that limit. This can cause the torque to be insufficient, or the acceleration time to be too long. Check to be sure that the value set for the torque limit is suitable.

If torque limits have been set for the multi-function analog input (H3-05 or H3-09 = 10 to 12 or 15), check to be sure that the analog input value is suitable.

■ The stall prevention level during acceleration is too low.

If the value set for L3-02 (Stall Prevention Level during Acceleration) is too low, the acceleration time will be too long. Check to be sure that the set value is suitable.

■ The stall prevention level during running is too low.

If the value set for L3-06 (Stall Prevention Level during Running) is too low, the speed will drop before outputting torque. Check to be sure that the set value is suitable.

■ Autotuning has not been performed for vector control

Vector control will not be performed if autotuning has not been performed. Perform autotuning separately for the motor, or set the motor constants through calculations. Alternatively, change the Control Method Selection (A1-02) to V/f control (0 or 1).

◆ If the Motor Operates Higher Than the Reference

Use the following information if the motor operates higher than the reference.

■ The analog frequency reference bias setting is wrong (the gain setting is wrong).

The frequency reference bias set in constant H3-03 is added to the frequency reference. Check to be sure that the set value is suitable.

■ A signal is being input to the frequency reference (current) terminal A1.

When 1F (frequency reference) is set for constant H3-09 (Multi-function Analog Input Terminal A2 Function Selection), a frequency corresponding to the terminal A2 input voltage (current) is added to the frequency reference. Check to be sure that the set value and analog input value are suitable.

◆ If the Slip Compensation Function Has Low Speed Precision

If speed control accuracy is low for the slip compensation function, the slip compensation limit has been reached. With the slip compensation function, compensation cannot be carried out beyond the slip compensation limit set in constant C3-03. Check to be sure that the set value is suitable.

◆ If There is Low Speed Control Accuracy at High-speed Rotation in Open-loop Vector Control Mode

The motor's rated voltage is high.

The Inverter's maximum output voltage is determined by its input voltage. (For example, if 200 VAC is input, then the maximum output voltage will be 200 VAC.) If, as a result of vector control, the output voltage reference value exceeds the Inverter output voltage maximum value, the speed control accuracy will decrease. Use a motor with a low rated voltage (i.e., a special motor for use with vector control), or change to flux vector control.

◆ If Motor Deceleration is Slow

Use the following information when the motor deceleration is slow.

■ The deceleration time is long even when braking resistor is connected.

The following causes are possible.

“Stall prevention during deceleration enabled” is set.

When braking resistor is connected, set constant L3-04 (Stall Prevention Selection during Deceleration) to 0 (disabled) or 3 (with braking resistor). When this constant is set to 1 (enabled, the factory setting), braking resistor does not fully function.

The deceleration time setting is too long.

Check the deceleration time setting (constants C1-02, C1-04, C1-06, and C1-08).

Motor torque is insufficient.

If the constants are correct and there is no overvoltage fault, then the motor's power is limited. Consider increasing the motor capacity.

The torque limit has been reached.

When a torque limit has been set in constants L7-01 to L7-04, no torque will be output beyond that limit. This can cause the deceleration time to be too long. Check to be sure that the value set for the torque limit is suitable.

If torque limits have been set for the multi-function analog input terminal A2 Function H3-09 (set value: 10 to 12 or 15), check to be sure that the analog input value is suitable.

■ If the Vertical-axis Load Drops When Brake is Applied

The sequence is incorrect. The Inverter goes into DC injection braking status for 0.5 seconds after deceleration is completed. (This is the factory-set default.)

To ensure that the brake holds, set frequency detection 2 (H2-01 = 5) for the multi-function contact output terminals (M1 and Mw) so that the contacts will turn OFF when the output frequency is greater than L4-01 (3.0 to 5.0 Hz). (The contacts will turn ON below L4-01.)

There is hysteresis in frequency detection 2 (i.e., a frequency detection width, L4-02 = 2.0 Hz). Change the setting to approximately 0.5 Hz if there are drops during stop. Do not use the multi-function contact output run signal (H2-01 = 0) for the brake ON/OFF signal.

◆ If the Motor Overheats

Take the following steps if the motor overheats.

■ The load is too big.

If the motor load is too heavy and the motor is used with the effective torque exceeding the motor's rated torque, the motor will overheat. Some motor ratings are given for short period performance and are not continuous ratings. Reduce the load amount by either lightening the load or lengthening the acceleration/deceleration time. Also consider increasing the motor capacity.

■ The ambient temperature is too high.

The motor rating is determined within a particular ambient operating temperature range. The motor will burn out if it is run continuously at the rated torque in an environment in which the maximum ambient operating temperature is exceeded. Lower the motor's ambient temperature to within the acceptable ambient operating temperature range.

■ The withstand voltage between the motor phases is insufficient.

When the motor is connected to the Inverter output, a surge is generated between the Inverter switching and the motor coil. Normally the maximum surge voltage is three times the Inverter's input power supply voltage (i.e., 1,200 V for 400 V class). Be sure to use a motor with a withstand voltage between the motor phases that is greater than the maximum surge voltage. In particular, when using a 400 V class Inverter, use a special motor for Inverters.

■ Autotuning has not been performed for vector control

Vector control will not perform if autotuning has not been performed. Perform autotuning, or set the motor constants through calculations. Alternatively, change the Control Method Selection (A1-02) to V/f control (0 or 1).

◆ If There is Noise When the Inverter is Started or From an AM Radio

If noise is generated by Inverter switching, implement the following countermeasures:

- Change the Inverter's Carrier Frequency Selection (C6-02) to lower the carrier frequency. This will help to some extent by reducing the amount of internal switching.
- Install an Input Noise Filter at the Inverter's power supply input area.
- Install an Output Noise Filter at the Inverter's power supply output area.
- Use metal tubing. Electric waves can be shielded by metal, so encase the Inverter with metal (steel).
- Ground the Inverter and motor.
- Separate main circuit wiring from control wiring.

◆ If the Ground Fault Interrupter Operates When the Inverter is Run

The Inverter performs internal switching, so there is a certain amount of leakage current. This may cause the ground fault interrupter to operate and cut off the power supply. Change to a ground fault interrupter with a high leakage detection level (i.e., a sensitivity current of 200 mA or greater per Unit, with an operating time of 0.1 s or more), or one that incorporates high frequency countermeasures (i.e., one designed for use with Inverters). It will also help to some extent to change the Inverter's Carrier Frequency Selection (C6-02) to lower the carrier frequency. In addition, remember that the leakage current increases as the cable is lengthened.

◆ If There is Mechanical Oscillation

Use the following information when there is mechanical oscillation.

■ The machinery is making unusual sounds.

The following causes are possible.

There may be resonance between the mechanical system's characteristic frequency and the carrier frequency.

If the motor is running with no problems and the machinery is oscillating with a high-pitched whine, it may indicate that this is occurring. To prevent this type of resonance, adjust the carrier frequency with constants C6-02 to C6-05.

There may be resonance between a machine's characteristic frequency and the output frequency of the Inverter.

To prevent this from occurring, either use the jump frequency functions in constants d3-01 to d3-04 or install rubber padding on the motor base to reduce oscillation.

■ Oscillation and hunting are occurring with open-loop vector control 1.

The gain adjustment may be insufficient. Reset the gain to a more effective level by adjusting constants C4-02 (torque compensation time constant), C2-01 (S-curve Characteristic Time at Acceleration Start), and C3-02 (Slip Compensation Primary Delay Time) in order. Lower the gain setting and raise the primary delay time setting.

Vector control will not perform if autotuning has not been performed. Perform autotuning separately for the motor, or set the motor constants through calculations. Alternatively, change the control method selection (A1-02) to V/f control (0 or 1).

■ Oscillation and hunting are occurring with V/f control.

The gain adjustment may be insufficient. Reset the gain to a more effective level by adjusting constants C4-02 (Torque Compensation Primary Delay Time Constant), N1-02 (Hunting Prevention Gain), and C3-02 (Slip Compensation Primary Delay Time) in order. Lower the gain setting and raise the primary delay time setting.

■ Oscillation and hunting are occurring with V/f w/PG control.

The gain adjustment may be insufficient. Adjust the various types of speed control loop (ASR) gain.

If the oscillation cannot be eliminated in this way, set the hunting prevention selection (constant N1-01) to 0 (disabled) and then try adjusting the gain again.

■ **Oscillation and hunting are occurring with flux vector control.**

The gain adjustment is insufficient. Adjust the various gains for speed control (ASR). If the oscillation points overlap with those of the machine and cannot be eliminated, increase the primary delay time constant for speed control (ASR) in C5-06 and then readjust the gains.

If autotuning is not performed, proper performance cannot be achieved for vector control. Perform autotuning or set the motor constants according to calculations.

■ **Oscillation and hunting are occurring with PID control.**

If there is oscillation or hunting during PID control, check the oscillation cycle and individually adjust P, I, and D constants. (Refer to page 6-97.)

■ **Autotuning has not been performed with vector control.**

Vector control will not perform if autotuning has not been performed. Perform autotuning separately for the motor, or set the motor constants through calculations. Alternatively, change the Control Method Selection (A1-02) to V/f control.

◆ **If the Motor Rotates Even When Inverter Output is Stopped**

If the motor rotates even when the Inverter output is stopped, the DC injection braking is insufficient. If the motor continues operating at low speed, without completely stopping, and after a deceleration stop has been executed, it means that the DC injection braking is not decelerating enough. Adjust the DC injection braking as follows:

- Increase the constant b2-02 (DC Injection Braking Current) setting.
- Increase the constant b2-04 (DC Injection Braking (initial excitation) Time at Stop) setting.

◆ **If 0 V is Detected When the Fan is Started, or Fan Stalls**

Generation of 0 V (main circuit voltage) and stalling can occur if the fan is turning when it is started. The DC injection braking is insufficient when starting.

This can be prevented by slowing fan rotation by DC injection braking before starting the fan. Increase the constant b2-03 (DC injection braking time (initial excitation) at start) setting.

◆ **If Output Frequency Does Not Rise to Frequency Reference**

Use the following information if the output frequency does not rise to the frequency reference.

■ **The frequency reference is within the jump frequency range.**

When the jump frequency function is used, the output frequency does not change within the jump frequency range. Check to be sure that the Jump Frequency (constants d3-01 to d3-03) and Jump Frequency Width (constant d3-04) settings are suitable.

■The frequency reference upper limit has been reached.

The output frequency upper limit is determined by the following formula:

Maximum Output Frequency (E1-04) × Frequency Reference Upper Limit (d2-01) / 100

Check to be sure that the constant E1-04 and d2-01 settings are suitable.



8

Maintenance and Inspection

This chapter describes basic maintenance and inspection for the Inverter

Maintenance and Inspection.....8-2

Maintenance and Inspection

◆ Outline of Maintenance

The maintenance period of the Inverter is as follows:

Maintenance Period: Within 18 months of shipping from the factory or within 12 months of being delivered to the final user, whichever comes first.

◆ Daily Inspection

Check the following items with the system in operation.

- The motor should not be vibrating or making unusual noises.
- There should be no abnormal heat generation.
- The ambient temperature should not be too high.
- The output current value shown on the monitor displays should not be higher than normal.
- The cooling fan on the bottom of the Inverter should be operating normally.

◆ Periodic Inspection

Check the following items during periodic maintenance.

Always turn OFF the power supply before beginning inspection. Confirm that the LCD and LED indicators on the front cover have all turned OFF, and then wait until at least five minutes has elapsed before beginning the inspection. Be sure not to touch terminals right after the power has been turned off. Doing so can result in electric shock.

Table 8.1 Periodic Inspections

Item	Inspection	Corrective Procedure
External terminals, mounting bolts, connectors, etc.	Are all screws and bolts tight?	Tighten loose screws and bolts firmly.
	Are connectors tight?	Reconnect the loose connectors.
Cooling fins	Are the fins dirty or dusty?	Clean off any dirt and dust with an air gun using dry air at a pressure of 39.2×10^4 to 58.8×10^4 Pa (4 to 6 kg•cm ²).
PCBs	Is there any conductive dirt or oil mist on the PCBs?	Clean off any dirt and dust with an air gun using dry air at a pressure of 39.2×10^4 to 58.8×10^4 Pa (4 to 6 kg•cm ²). Replace the boards if they cannot be made clean.
Cooling fan	Is there any abnormal noise or vibration or has the total operating time exceeded 20,000 hours?	Replace the cooling fan.
Power elements	Is there any conductive dirt or oil mist on the elements?	Clean off any dirt and dust with an air gun using dry air at a pressure of 39.2×10^4 to 58.8×10^4 Pa (4 to 6 kg•cm ²).
Smoothing capacitor	Are there any irregularities, such as discoloration or odor?	Replace the capacitor or Inverter.

◆ Periodic Maintenance of Parts

The Inverter is configured of many parts, and these parts must be operating properly in order to make full use of the Inverter functions.

Among the electronic components, there are some that require maintenance depending on their usage conditions. In order to keep the Inverter operating normally over a long period of time, it is necessary to perform period inspections and replace parts according to their service life.

Periodic inspection standards vary depending the Inverter's installation environment and usage conditions. The Inverter's maintenance periods are noted below. Keep them as reference.

Table 8.2 Part Replacement Guidelines

Part	Standard Replacement Period	Replacement Method
Cooling fan	2 to 3 years	Replace with new part.
Smoothing capacitor	5 years	Replace with new part. (Determine need by inspection.)
Breaker relays	-	Determine need by inspection.
Fuses	10 years	Replace with new part.
Aluminum capacitors on PCBs	5 years	Replace with new board. (Determine need by inspection.)

Note The standard replacement period is based on the following usage conditions:
Ambient temperature: Yearly average of 30°C
Load factor: 80% max.
Operating rate: 12 hours max. per day

◆ Cooling Fan Replacement Outline

■ 200 V and 400 V Class Inverters of 15 kW or Less

A cooling fan is attached to the bottom of the Inverter.

If the Inverter is installed using the mounting holes on the back of the Inverter, the cooling fan can be replaced without removing the Inverter from the installation panel.

Removing the Cooling Fan

1. Press in on the right and left sides of the fan cover in the direction of arrows 1 and when pull the fan out in the direction of arrow 2.
2. Pull out the cable connected to the fan from the fan cover and disconnect the relay connector.
3. Open the fan cover on the left and right sides and remove the fan cover from the fan.

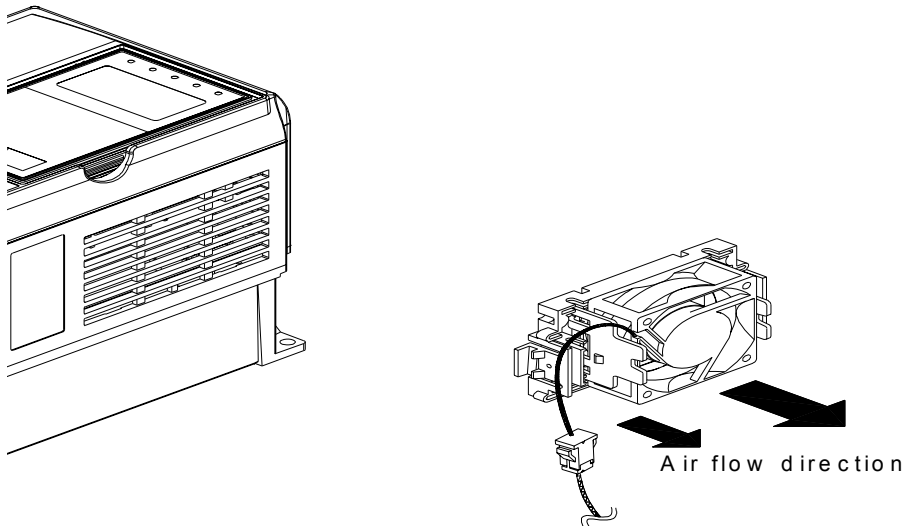

Fig 8.1 Cooling Fan Replacement (Inverters of 15 kW or Less)

Mounting the Cooling Fan

1. Attach the fan cover to the cooling fan. Be sure that the air flow direction indicated by the arrows above faces into the Inverter.
2. Connect the relay connector securely and place the relay connector and cable into the fan cover.
3. Mount the fan cover on the Inverter. Be sure that the tabs on the sides of the fan cover click into place on the Inverter.

■ 200 V and 400 V Class Inverters of 18.5 kW or More

A cooling fan is attached to the top panel inside the Inverter.

The cooling fan can be replaced without removing the Inverter from the installation panel.

Removing the Cooling Fan

1. Remove the terminal cover, Inverter cover, Digital Operator, and front cover from the front of the Inverter.
2. Remove the controller bracket to which the cards are mounted. Remove all cables connected to the controller.
3. Remove the cooling fan power cable connector (CN26 and CN27) from the gate driver positioned at the back of the controller.
4. Remove the fan cover screws and pull out the fan cover from the Inverter.
5. Remove the cooling fan from the fan cover.

Mounting the Cooling Fan

After attaching a new cooling fan, reverse the above procedure to attach all of the components.

When attaching the cooling fan to the mounting bracket, be sure that the air flow faces the top of the Inverter.

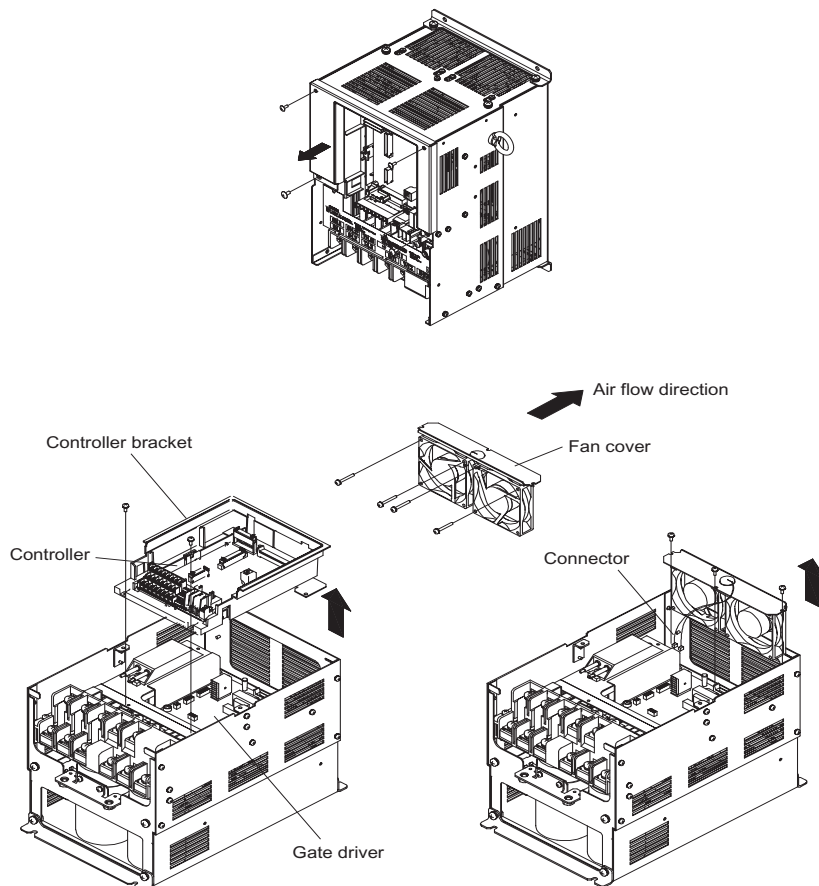

Fig 8.2 Cooling Fan Replacement (Inverters of 18.5 kW or More)

◆ Removing and Mounting the Control Circuit Terminal Card

The control circuit terminal card can be removed and mounted without disconnecting the cables.



Always confirm that the charge indicator is not lit before removing or mounting the control circuit terminal card.

■ Removing the Control Circuit Terminal Card

1. Remove the Digital Operator and front cover.
2. Remove the connecting line connectors connected to FE and NC on the control circuit terminal card.
3. Loosen the mounting screws (1) on the left and right sides of the control terminals until they are free. (It is not necessary to remove these screws completely. They are self-rising.)
4. Pull the terminal card out sideways (in direction 2) with the screws sticking out from the card.

■ Mounting the Control Circuit Terminal Card

Reverse the removal procedure to mount the terminal card.

Confirm that the terminal circuit card and the controller properly meet at connector CN5 before pressing in on the card.

The connector pins may be bent if the card is forced into place, possibly preventing correct Inverter operation.

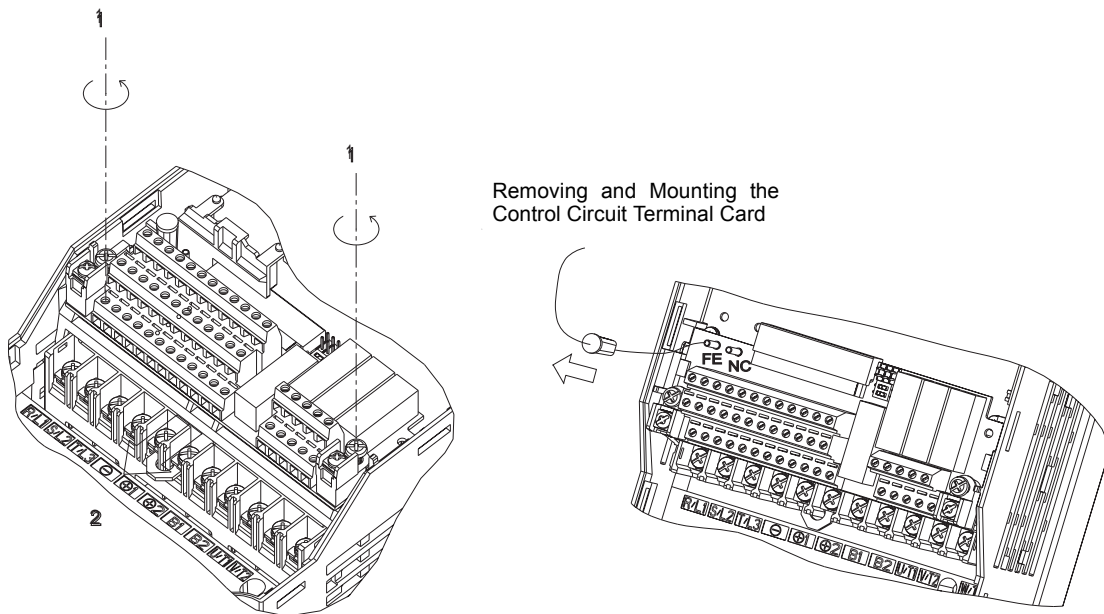

Fig 8.3 Removing the Control Circuit Terminal Card



9

Specifications

This chapter describes the basic specifications of the Inverter and specifications for options and peripheral devices.

Standard Inverter Specifications	9-2
Specifications of Options and Peripheral Devices	9-5

Standard Inverter Specifications

The standard Inverter specifications are listed by capacity in the following tables.

◆ Specifications by Model

Specifications are given by model in the following tables.

■ 200V Class

Table 9.1 200 V Class Inverters

Model Number CIMR-G7C □	20P4	20P7	21P5	22P2	23P7	25P5	27P5	2011	2015	2018	2022	2030	2037	2045	2055	2075	2090	2110	
Max. applicable motor output (kW)	0.4	0.75	1.5	2.2	3.7	5.5	7.5	11	15	18.5	22	30	37	45	55	75	90	110	
Output ratings	Rated output capacity (kVA)	1.2	2.3	3.0	4.6	6.9	10	13	19	25	30	37	50	61	70	85	110	140	160
	Rated output current (A)	3.2	6	8	12	18	27	34	49	66	80	96	130	160	183	224	300	358	415
Output ratings	Max. output voltage (V)	3-phase; 200, 208, 220, 230, or 240 VAC (Proportional to input voltage.)																	
	Max. output frequency (Hz)	Frequencies supported up to 400 Hz using constant setting																	
Power supply characteristics	Rated voltage (V) Rated frequency (Hz)	3-phase, 200/208/220/230/240 VAC, 50/60 Hz*2																	
	Allowable voltage fluctuation	+ 10%, - 15%																	
	Allowable frequency fluctuation	±5%																	
Measures for power supply harmonics	DC reactor	Optional							Built in										
	12-phase rectification	Not possible							Possible*3										

- * 1. The maximum applicable motor output is given for a standard 4-pole Yaskawa motor. When selecting the actual motor and Inverter, be sure that the Inverter's rated current is applicable for the motor's rated current.
- * 2. The voltage of the cooling fan for 200 V Class Inverters of 30 kW is three-phase, 200, 208, or 220 V at 50 Hz or 200, 208, 220, or 230 V at 60 Hz.
- * 3. A 3-wire transformer is required on the power supply for 12-phase rectification.

■400 V Class

Table 9.2 400 V Class Inverters

Model Number CIMR-G7C □		40P4	40P7	41P5	42P2	43P7	45P5	47P5	4011	4015	4018
Max. applicable motor output (kW) *1		0.4	0.75	1.5	2.2	3.7	5.5	7.5	11	15	18.5
Output ratings	Rated output capacity (kVA)	1.4	2.6	3.7	4.7	6.9	11	16	21	26	32
	Rated output current (A)	1.8	3.4	4.8	6.2	9	15	21	27	34	42
Output ratings	Max. output voltage (V)	3-phase; 380, 400, 415, 440, 460, or 480 VAC (Proportional to input voltage.)									
	Max. output frequency (Hz)	Frequencies supported up to 400 Hz using constant setting									
Power supply characteristics	Rated voltage (V) Rated frequency (Hz)	3-phase, 380, 400, 415, 440, 460 or 480 VAC, 50/60 Hz									
	Allowable voltage fluctuation	+ 10%, - 15%									
	Allowable frequency fluctuation	±5%									
Measures for power supply harmonics	DC reactor	Optional									Built in
	12-phase rectification	Not possible									Possible*2

Model Number CIMR-G7C □		4022	4030	4037	4045	4055	4075	4090	4110	4132	4160	4185	4220	4300
Max. applicable motor output (kW) *1		22	30	37	45	55	75	90	110	132	160	185	220	300
Output ratings	Rated output capacity (kVA)	40	50	61	74	98	130	150	180	210	230	280	340	460
	Rated output current (A)	52	65	80	97	128	165	195	240	270	302	370	450	605
Output ratings	Max. output voltage (V)	3-phase, 380, 400, 415, 440, 460, or 480 VAC (Proportional to input voltage.)												
	Max. output frequency (Hz)	Frequencies supported up to 400 Hz using constant setting												
Power supply characteristics	Max. voltage (V) Rated frequency (Hz)	3-phase, 380, 400, 415, 440, 460, or 480 VAC, 50/60 Hz												
	Allowable voltage fluctuation	+ 10%, - 15%												
	Allowable frequency fluctuation	±5%												
Measures for power supply harmonics	DC reactor	Built in												
	12-phase rectification	Possible*2												

* 1. The maximum applicable motor output is given for a standard 4-pole Yaskawa motor. When selecting the actual motor and Inverter, be sure that the Inverter's rated current is applicable for the motor's rated current.

* 2. A 3-wire transformer (optional) is required on the power supply for 12-phase rectification.

◆ Common Specifications

The following specifications apply to both 200 V and 400 V Class Inverters.

Table 9.3 Common Specifications

Model Number CIMR-G7C □	Specification	
Control characteristics	Control method	Sine wave PWM Flux vector control, open-loop vector control 1 or 2, V/f control with PG (switched by constant setting)
	Torque characteristics	150%/0.3 Hz (Open-loop vector control 2), 150%/0 min ⁻¹ (Flux vector control)* ¹
	Speed control range	1:200 (Open-loop vector control 2), 1:1000 (Flux vector control)* ¹
	Speed control accuracy	±0.2% (Open-loop vector control, 25°C ± 10°C), ±0.02% (Flux vector control, 25°C ± 10°C)
	Speed control response	10 Hz (Open-loop vector control 2), 30 Hz (Flux vector control)
	Torque limits	Provided for vector control only (4 quadrant steps can be changed by constant settings.)
	Torque accuracy	±5%
	Frequency control range	0.01 to 400 Hz* ³
	Frequency accuracy (temperature characteristics)	Digital references: ± 0.01% (-10°C to +40°C)
		Analog references: ±0.1% (25°C ± 10°C)
	Frequency setting resolution	Digital references: 0.01 Hz, Analog references: 0.03 Hz/60 Hz (11 bit with no sign)
	Output frequency resolution	0.001 Hz
	Overload capacity and maximum current* ²	150% of rated output current per minute, 200% for 5 s
	Frequency setting signal	-10 to 10 V, 0 to 10 V, 4 to 20 mA, pulse train
	Acceleration/Deceleration time	0.01 to 6000.0 s (4 selectable combinations of independent acceleration and deceleration settings)
Braking torque	Approximately 20% (Approximately 125% with Braking Resistor option, braking transformer built into 200 V and 400 V Class Inverters for 15 kW or less.)* ²	
Main control functions	Restarting for momentary power loss, speed searches, overtorque detection, torque limits, 17-speed control (maximum), acceleration/deceleration time changes, S-curve acceleration/deceleration, 3-wire sequence, autotuning (rotational or stationary), dwell functions, cooling fan ON/OFF control, slip compensation, torque compensation, jump frequencies, upper and lower limits for frequency references, DC braking for starting and stopping, high-slip braking, PID control (with sleep function), energy-saving control, MEMOBUS communications (RS-485/422, 19.2 kbps maximum), fault reset, function copying, droop control, torque control, speed/torque control switching, etc.	
Protective functions	Motor protection	Protection by electronic thermal overload relay.
	Instantaneous overcurrent protection	Stops at approx. 200% of rated output current.
	Fuse blown protection	Stops for fuse blown.
	Overload protection	150% of rated output current per minute, 200% for 5 s
	Overvoltage protection	200 Class Inverter: Stops when main-circuit DC voltage is above 410 V. 400 Class Inverter: Stops when main-circuit DC voltage is above 820 V.
	Undervoltage protection	200 Class Inverter: Stops when main-circuit DC voltage is below 190 V. 400 Class Inverter: Stops when main-circuit DC voltage is below 380 V.
	Momentary power loss ridthrough	Stops for 15 ms or more. By selecting the momentary power loss method, operation can be continued if power is restored within 2 s.
	Cooling fin overheating	Protection by thermistor.
	Stall prevention	Stall prevention during acceleration, deceleration, or running.
	Grounding protection	Protection by electronic circuits.
Charge indicator	Lit when the main circuit DC voltage is approx. 50 V or more.	
Environment	Ambient operating temperature	-10°C to 40°C (Enclosed wall-mounted type) 10°C to 45°C (Open chassis type)
	Ambient operating humidity	95% max. (with no condensation)
	Storage temperature	- 20°C to + 60°C (short-term temperature during transportation)
	Application site	Indoor (no corrosive gas, dust, etc.)
	Altitude	1000 m max.
Vibration	Tolerance for vibration frequency less than 20 Hz, 9.8 m/s ² max.; 20 to 50 Hz, 2 m/s ² max	

* 1. Rotational autotuning must be performed to ensure obtaining the specifications given for flux vector control and open-loop vector control 1 and 2.

* 2. When connecting a Braking Resistor or Braking Resistor Unit, set L3-04 (Stall prevention selection during deceleration) to 0 (disabled). Stopping may not be possible in the specified deceleration time if this function is not disabled.

* 3. The maximum output frequency for open-loop vector control 2 is 60 Hz.

Specifications of Options and Peripheral Devices

The following options and peripheral devices can be used for the Inverter. Select them according to the application.

Table 9.4 Options and Peripheral Devices

Purpose	Name	Model (Code)	Descriptions
Protect Inverter wiring	MCCB or Ground Fault Interrupter*1	NF□	Always connect a breaker to the power supply line to protect Inverter wiring. Use a ground fault interrupter suitable for high frequencies.
Prevents burning when a Braking Resistor is used.	Magnetic Contactor	HI-□J	Install to prevent the braking resistor from burning out when one is used. Always attach a surge absorber to the coil.
Contains switching surge	Surge Absorber	DCR2-□	Absorbs surge from the magnetic contactor and control relays. Connect surge absorbers to all magnetic contactors and relays near the Inverter.
Isolates I/O signals	Isolator	DGP□	Isolates the I/O signals of the Inverter and is effective against inductive noise.
Improve the input power factor of the Inverter	DC Reactor AC Reactor	UZDA-□ UZBA-□	Used to improve the input power factor of the Inverter. All Inverters of 18.5 kW or higher contain built-in DC reactors. These are optional for Inverters of 15 kW or less. Install DC and AC reactors for applications with a large power supply capacity (600 kVA or higher).
Reduce the affects of radio and control device noise	Input Noise Filter	(Single phase) LNFB-□ (3 phase) LNFD-□HF□	Reduces noise coming into the inverter from the power supply line and to reduce noise flowing from the inverter into the power supply line. Connect as close to the Inverter as possible.
	Finemet zero-phase reactor to reduce radio noise*2	F6045GB (FIL001098) F11080GB (FIL001097)	Reduces noise from the line that sneaks into the Inverter input power system. Insert as close to the Inverter as possible. Can be use on both the input side and output side.
	Output Noise Filter	LF-o	Reduces noise generated by the Inverter. Connect as close to the Inverter as possible.
Enable stopping the machine in a set time	Braking Resistor	ERF-150WJ□□ (R00□□□□)	Consumes the regenerative motor energy with a resistor to reduce deceleration time (use rate: 3% ED).
	Braking Resistor Unit	LKEB-□ (75600-K□□□0)	Consumes the regenerative motor energy with a resistor to reduce deceleration time (use rate: 10% ED).
	Braking Unit	CDBR-□ (72600-R□□□0)	Used with a Braking Resistor Unit to reduce the deceleration time of the motor.
Operates the Inverter externally	VS Operator (small plastic Operator)	JVOP-95•□ (73041-0905X-□)	Allows frequency reference settings and ON/OFF operation control to be performed by analog references from a remote location (50 m max.). Frequency counter specifications: 60/120 Hz, 90/180Hz
	VS Operator (Standard steel-plate Operator)	JVOP-96•□ (73041-0906X-□)	Allows frequency reference settings and ON/OFF operation control to be performed by analog references from a remote location (50 m max.). Frequency counter specifications: 75 Hz, 150 Hz, 220 Hz
	Digital Operator Connection Cable	1 m cable: (72606-WV001) 3 m cable: (72606-WV003)	Extension cable to use a Digital Operator remotely. Cable length: 1 m or 3 m
Controls an Inverter system	VS System Module	JGSM-□	A system controller that can be match to the automatic control system to produce an optimum system configuration.
Provides Inverter momentary power loss recovery time	Momentary Power Loss Recovery Unit	P00□0 (73600-P00□0)	Handles momentary power losses for the control power supply for models 2.2 kW or less (maintains power for 2 s).
Set/monitor frequencies and voltages externally.	Frequency Meter	DCF-6A	Devices to set or monitor frequencies externally.
	Frequency Setter	RV30YN20S (2 kΩ)	
	Frequency Setter Knob	CM-3S	
	Output Voltmeter	SCF-12NH	Measures the output voltage externally and designed for use with a PWM Inverter.
Correct frequency reference input, frequency meter, ammeter scales	Variable Resistor Board for Frequency Reference	2 kΩ (ETX003270) 20 kΩ (ETX003120)	Connected to the control circuit terminals to input a frequency reference.
	Frequency Meter Scale Correction Resistor	(RH000850)	Calibrates the scale of frequency meters and ammeters.

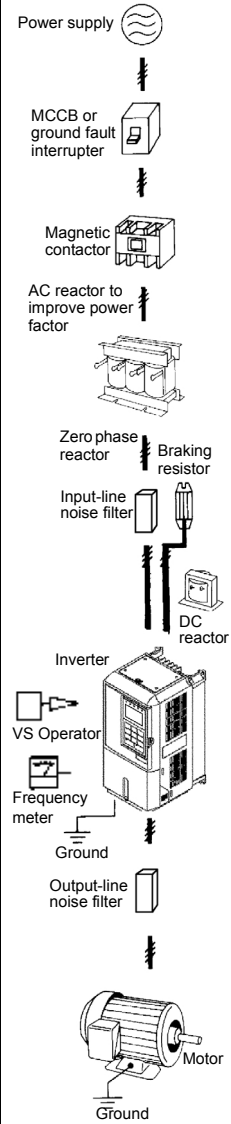

* 1. Use a ground fault interrupter with a current sensitivity of 200 mA minimum and an operating time of 0.1 s minimum to prevent operating errors. The interrupter must be suitable for high-frequency operation.
Example: NV series by Mitsubishi Electric Corporation (manufactured in or after 1988)
EG, SG series by Fuji Electric Co., Ltd. (manufactured in or after 1984)

* 2. The finemet zero-phase reactor is manufactured by Hitachi Metals.

The following Option Cards are available

Table 9.5 Option Cards

Type	Name	Code Number	Function	Document Number	
Built-in (connect to connector)	Speed (Frequency) Reference Option Cards	Analog Reference Card AI-14U	73600-C001X	Enables high-precision, high-resolution setting of analog speed references. <ul style="list-style-type: none"> Input signal ranges: 0 to 10 V (20 kΩ), 1 channel 4 to 20 mA (250 Ω), 1 channel Input resolution: 14-bit (1/16384) 	TO-C736-30.13
		Analog Reference Card AI-14B	73600-C002X	Enables high-precision, high-resolution setting of analog speed references. <ul style="list-style-type: none"> Input signal ranges: 0 to \pm10 V (20 kΩ) 4 to 20 mA (500 Ω), 3 channels Input resolution: 13-bit + sign (1/8192) 	TO-C736-30.14
		Digital Reference Card DI-08	73600-C003X	Enables 8-bit digital setting of speed references. <ul style="list-style-type: none"> Input signal: 8-bit binary 2-digit BCD + sign signal + set signal Input voltage: +24 V (isolated) Input current: 8 mA 	TO-C736-30.15
		Digital Reference Card DI-16H2	73600-C016X	Enables 16-bit digital setting of speed references. <ul style="list-style-type: none"> Input signal: 16-bit binary 4-digit BCD + sign signal + set signal Input voltage: +24 V (isolated) Input current: 8 mA With 16-bit/12-bit switch.	TO-C736-40.7
	Monitoring Optional Cards	Analog Monitor Card AO-08	73600-D001X	Converts analog signals to monitor the Inverter's output status (output frequency, output current, etc.) to absolute values and outputs them. <ul style="list-style-type: none"> Output resolution: 8 bits (1/256) Output voltage: 0 to +10 V (not insulated) Output channels: 2 channels 	TO-C736-30.21
		Analog Monitor Card AO-12	73600-D002X	Output analog signals to monitor the Inverter's output status (output frequency, output current, etc.). <ul style="list-style-type: none"> Output resolution: 11 bits (1/2048) + sign Output voltage: -10 to +10 V (not insulated) Output channels: 2 channels 	TO-C736-30.22
		Digital Output Card DO-08	73600-D004X	Outputs isolated digital signals to monitor the Inverters operating status (alarm signals, zero speed detection, etc.) Output form: Photocoupler output, 6 channels (48 V, 50 mA max.) Relay contact outputs, 2 channels (250 VAC: 1 A max., 30VDC: 1 A max.)	TO-C736-30.24
		2C-Relay Output Card DO-02C	73600-D007X	Provides two multi-function outputs (DPDT relay contacts) in addition to those provided by the Inverter.	TO-C736-40.8

Table 9.5 Option Cards (Continued)

Type		Name	Code Number	Function	Document Number
Built-in (connect to connector)	PG Speed Control Cards	PG-A2	73600-A012X	Used for V/f with PG control. Speed feedback is performed using the PG attached to the motor to compensate for speed fluctuations caused by slipping. <ul style="list-style-type: none"> • A-phase pulse (single pulse) input (voltage, complementary, open-collector input) • Maximum input frequency: 32767 Hz • Pulse monitor output: +12 V, 20 mA (PG power supply output: +12 V, 200 mA max.)	TO-C736-40.1
		PG-B2	73600-A013X	<ul style="list-style-type: none"> • Used for V/f control. • A-, B-phase input (complimentary input) • Maximum input frequency: 32767 Hz • Pulse monitor output: Open-collector (PG power supply output: +12 V, 200 mA max.)	TO-C736-40.2
		PG-D2	73600-A014X	<ul style="list-style-type: none"> • Differential input. • A-phase pulse (differential pulse) input, for V/f control • Maximum input frequency: 300 kHz • Input: Conforms to RS-422 • Pulse monitor output: RS-422 (PG power supply output: +5 or +12 V, 200 mA max.)	TO-C736-40.3
		PG-X2	73600-A015X	<ul style="list-style-type: none"> • A-, B-, Z-phase pulse (differential pulse) input • Maximum input frequency: 300 kHz • Input: Conforms to RS-422 • Pulse monitor output: RS-422 (PG power supply output: +5 or +12 V, 200 mA max.)	TO-C736-40.4

Table 9.5 Option Cards (Continued)

Type	Name	Code Number	Function	Document Number	
Built-in (connected to connector)	Communications Option Cards	DeviceNet Communications Interface Card SI-N	73600-C021X	Used to communicate with an Inverter from a host computer using DeviceNet communications to start/stop Inverter operation, read/set parameters, and read/set monitor constants (output frequencies, output currents, etc.).	-
		ProfiBus-DP Communications Interface Card SI-P	73600-C022X	Used to communicate with an Inverter from a host computer using ProfiBus-DP communications to start/stop Inverter operation, read/set parameters, and read/set monitor constants (output frequencies, output currents, etc.).	-
		InterBus-S Communications Interface Card SI-R	*	Used to communicate with an Inverter from a host computer using InterBus-S communications to start/stop Inverter operation, read/set parameters, and read/set monitor constants (output frequencies, output currents, etc.).	-
		CANopen Communications Interface Card SI-S	*	Used to communicate with an Inverter from a host computer using CANopen communications to start/stop Inverter operation, read/set parameters, and read/set monitor constants (output frequencies, output currents, etc.).	-
		ControlNet Communications Interface Card SI-U	*	Used to communicate with an Inverter from a host computer using ControlNet communications to start/stop Inverter operation, read/set parameters, and read/set monitor constants (output frequencies, output currents, etc.).	-
		CC-Link Communications Interface Card SI-C	73600-C032X	Used to communicate with an Inverter from a host computer using CC-Link communications to start/stop Inverter operation, read/set parameters, and read/set monitor constants (output frequencies, output currents, etc.).	-

* Under development.



10

Appendix

This chapter provides precautions for the Inverter, motor, and peripheral devices and also provides lists of constants.

Varispeed G7 Control Modes	10-2
Inverter Application Precautions	10-7
Motor Application Precautions	10-10
Conformance to CE Markings.....	10-12
User Constants	10-19

Varispeed G7 Control Modes

Details of the Varispeed G7-Series Inverter control modes and their features are provided in this section.

◆ Control Modes and Features

Varispeed G7-Series Inverters support the following five control modes, allowing the selection of a control mode to suit the required purpose. *Table 10.1* provides an overview of the control modes and their features.

Table 10.1 Overview and Features of Control Modes

Control Mode		V/f Control without PG	V/f Control with PG	Open-loop Vector Control 1	Flux Vector Control	Open-loop Vector Control 2
Constant Setting		A1-02 = 0	A1-02 = 1	A1-02 = 2 (factory setting)	A1-02 = 3	A1-02 = 4
Basic Control		Voltage/frequency fixed ratio control	Voltage/frequency fixed ratio control with speed compensation using a PG	Current vector control without a PG	Current vector control with a PG	Current vector control without a PG using a high-performance magnetic flux and speed estimator (software)
Main Applications		Variable speed control, particularly for control of multiple motors with a single Inverter and for replacing existing Inverters	Applications requiring high-precision speed control using a PG on the machine side	Variable speed control, applications requiring high performance without a PG on the motor side, and for replacing open-loop vector control of the previous VS-616G5.	Very high-performance control with a PG on the motor side (simple servodrives, high-precision speed control, torque control, and torque limiting)	Very high-performance control without a PG on the motor side (such as simple servodrives, torque control, and torque limiting), and function applications between flux vector and open-loop vector 1 control.
PG Speed Control Card (Option)		Not required.	Required (PG-A2 or PG-D2).	Not required.	Required (PG-B2 or PG-X2).	Not required.
Basic Performance	Speed Control Range* ¹	1:40	1:40	1:100	1:1000	1:200* ¹³
	Speed Control Accuracy* ²	±2 to 3%	±0.03%	±0.2%	±0.02%	±0.2%
	Speed Response* ³	Approx. 1 Hz	Approx. 1 Hz	5 Hz	40 Hz	10 Hz
	Maximum Output Frequency	400 Hz	400 Hz	400 Hz	400 Hz	60 Hz* ¹³
	Starting Torque* ⁴	150%/3 Hz	150%/3 Hz	150%/1 Hz	150%/0 min ⁻¹	150%/0.3 Hz

Table 10.1 Overview and Features of Control Modes

Control Mode		V/f Control without PG	V/f Control with PG	Open-loop Vector Control 1	Flux Vector Control	Open-loop Vector Control 2
Application Functions	Autotuning	Line-to-line resistance (Normally not required.)	Line-to-line resistance (Normally not required.)	Rotational autotuning, stationary autotuning, stationary autotuning for line-to-line resistance only	Rotational autotuning, stationary autotuning, stationary autotuning for line-to-line resistance only	Rotational autotuning, stationary autotuning, stationary autotuning for line-to-line resistance only
	Torque Limiting ^{*5}	No	No	Yes (except during acceleration/ deceleration, below minimum frequency, or during reverse rotation)	Yes	Yes (except below minimum frequency and during reverse rotation)
	Torque Control ^{*6}	No	No	No	Yes	Yes (except below minimum frequency and during reverse rotation)
	Droop Control ^{*7}	No	No	No	Yes (except for 0 min ⁻¹ and during reverse rotation)	Yes (Except below minimum frequency and during reverse rotation)
	Zero-servo Control ^{*8}	No	No	No	Yes	No
	Speed Estimation (Detection) Instantaneous Speed Search ^{*9}	Yes (speed and rotation direction estimation)	Yes (speed detection and rotation direction estimation)	Yes (speed and rotation direction estimation)	Yes (speed and rotation direction detection)	Yes (speed and rotation direction estimation)
	Automatic Energy-saving Control ^{*10}	Yes	Yes	Yes	Yes	Yes
	High-slip Braking ^{*11}	Yes	Yes	(Under development)	(Under development)	(Under development)
	Feed Forward Control ^{*12}	No	No	No	Yes	Yes

* 1. The variable speed control range. (For continuous operation, the motor's temperature rise must be considered.)
 * 2. The speed deviation in relation to the maximum speed with a rated load and when the load is stable. (For open-loop vector control 1 and 2, the motor temperature must be 25 °C ± 10 °C.)
 * 3. The speed response guidelines indicating the extent of the motor's actual speed gain in proportion to the speed reference, which changes in a sinusoidal wave form, within a range where motor torque does not become saturated.
 * 4. A guideline for the motor torque that can be generated when started at a low speed and its output frequency (rotations) at that time.
 * 5. This function limits the maximum motor torque to protect the machine and the load.
 * 6. This function directly controls the amount of torque being generated at the motor and its rotation direction, e.g., to control force.
 * 7. This function controls the amount of motor slip that occurs to prevent mechanical shock, when replacing a torque motor, etc.
 * 8. This function performs simple positioning control (servo lock), without using an external positioning control device.
 * 9. This function instantaneously estimates (or detects) the speed and rotation direction of a coasting motor, and quickly starts it without subjecting it to shock.
 * 10. This function automatically adjusts the voltage applied to the motor to optimize the motor's efficiency with light loads.
 * 11. This function improves the deceleration time without using a braking resistor by making the motor winding absorb regenerative power. As a standard, this function is effective with a motor running on 160 kW or less with a high-inertia load.
 * 12. This function enables proportional gain in relation to changes in the speed reference, even for low rigidity (corresponds to the servo's model gain control).
 * 13. Set the maximum output frequency (E1-04) for open-loop vector control 2 to a value not exceeding 60 Hz. Use within a speed control range of 1:10 for torque control on the regenerative side.

■ Application Function Precautions

Observe the following precautions when using the application functions.

- Perform rotational autotuning during trial operation whenever it is possible to separate the motor and machine. To achieve the characteristics of vector control described in *Table 10.1*, the control must be adjusted within a range that the machine will not vibrate after rotational autotuning has been performed.
- With vector control, the motor and Inverter must be connected 1:1. Vector control is not possible when multiple motors are connected to a single Inverter. Select an Inverter capacity so the rated motor current is 50% to 100% of the rated Inverter current.
- For estimated speed searching, the motor and Inverter must be connected 1:1. The speed search must be performed at a frequency of 130 Hz or less and with a motor with the same number of frames as or one frame less than the Inverter capacity.
- During high-slip braking, motor loss increases, so use a high-slip braking frequency of 5% ED or less, and a braking time of 90 seconds or less. Once high-slip braking has started, the motor cannot be restarted until it has stopped.
- Feed forward control is a function that improves the proportional gain of the motor speed in relation to the change in the speed reference. Adjust the response to interference loads using the speed controller (ASR) constants.
- The torque limit function will not operate during acceleration or deceleration (during soft start transition) when using a control mode such as open-loop vector control 1. Even if the motor speed drops due to torque limiting while set to a fixed speed, the speed will not fall below the minimum frequency and the motor will not slip into reverse rotation. These conditions also apply to open-loop vector control 2 and other application functions.

■ Precautions When Using Open-loop Vector Control 2

Using open-loop vector control 2 (A1-02=4) gives a higher level of control than conventional open-loop vector control (A1-02=2). When using open-loop vector control 2, pay attention to the points listed below. For a comparison with other control modes, refer to *Table 10.1 Overview and Features of Control Modes*.

General Precautions

- The maximum possible setting for the maximum output frequency (E1-04) is 60 Hz.
- Be sure to perform autotuning. Refer to the precautions given under *Autotuning* in *Chapter 4 Trial Operation*.

Precaution on Regeneration

With speed control, in the low speed range (approx. 6 Hz max.), the speed increases for large regenerative loads, and it may not be possible to maintain speed accuracy. Examples are given below for forward rotation at frequencies of 0.3, 1, 3, 6, and 60 Hz.

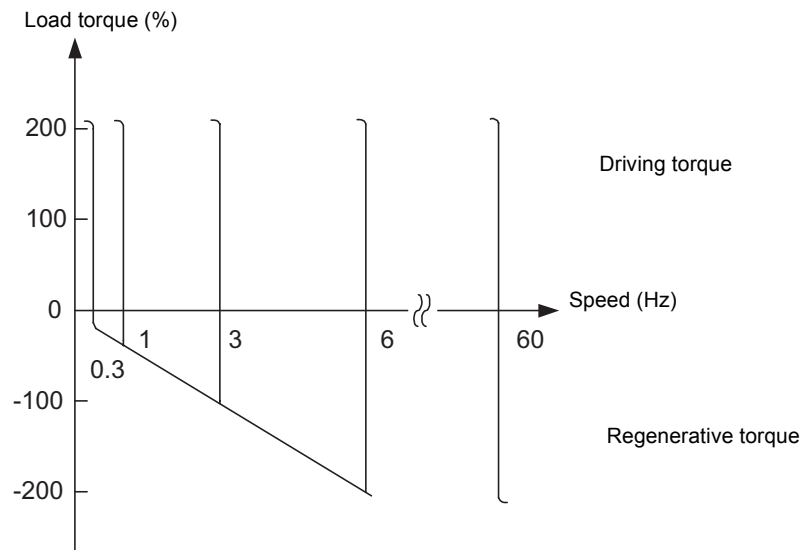

With torque control, operate within a speed control range of 1:10 on the regenerative side.

Precautions on Setting Constants

If the constants are not set properly, performance may be adversely affected.

- If there is a possibility of starting with the motor already rotating, enable the speed search function (b3-01=1).
- When lowering a torque limit (L7-□□), set it to as high a value as possible within the range allowed by the system.
- If torque limit acceleration is performed, or if the motor slips at the torque limit causing a CF (control fault), increase N4-08 (proportional gain of speed estimator) in steps of 5 until acceleration and deceleration are performed smoothly. When N4-08 is increased, the torque reference (U1-09) may oscillate. If so, increase C5-06 (ASR primary delay time) by about 0.050 s.

Precaution on Torque Accuracy

To ensure torque accuracy within the speed control range of 1:10 when the motor is operated by itself at the minimum frequency and the torque reference (U1-09) is higher than in the medium- and high-speed ranges, increase the setting of the torque adjustment gain (N4-17) and adjust the torque reference so that it is about the same as that in the medium and high speed ranges.

◆ Control Modes and Applications

Application examples for the Inverter control modes are provided here.

■ V/f Control without PG (A1-02 = 0)

V/f control without a PG is suitable for applications where multiple motors are operated with a single Inverter, such as with multi-motor drives.

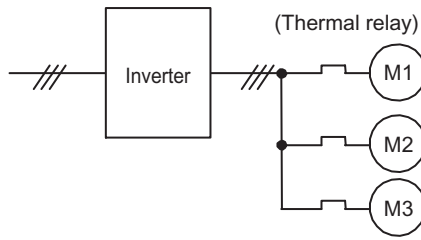

Fig 10.1

■ **V/f Control with PG (A1-02 = 1)**

V/f control with a PG enables precise control of machine line speed. Speed control using the speed feedback of the machine shaft is possible in this mode.

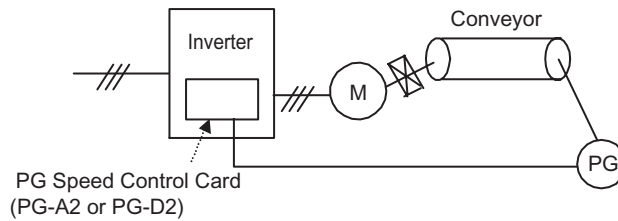

Fig 10.2

■ **Flux Vector Control (A1-02 = 2 or 4)**

Flux vector control enables the use of high-performance drives without a speed detector. PG (pulse generator) wiring is not required.

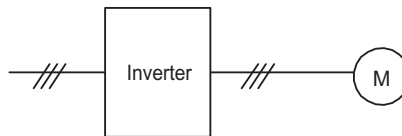

Fig 10.3

■ **Vector Control with PG (A1-02 = 3)**

Vector control with a PG is suitable for applications using high-precision drives with PG feedback. High-precision positioning, zero-speed control, and torque control are possible with this mode.

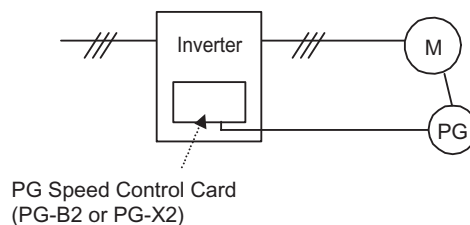

Fig 10.4

Inverter Application Precautions

This section provides precautions for selecting, installing, setting, and handling Inverters.

◆ Selection

Observe the following precautions in selecting an Inverter.

■ Installing Reactors

A large peak current will flow in the power input circuit when the Inverter is connected to a large-capacity power transformer (600 kVA or higher) or when switching a phase capacitor. Excessive peak current can destroy the convertor section. To prevent this, install a DC or AC reactor (optional) to improve the power supply power factor.

DC reactors are built into 200 V class Inverters of 18.5 to 110 kW and 400 V class Inverters of 18.5 to 300 kW.

If a thyristor convertor, such as a DC drive, is connected in the same power supply system, connect a DC or AC reactor regardless of the power supply conditions shown in the following diagram.

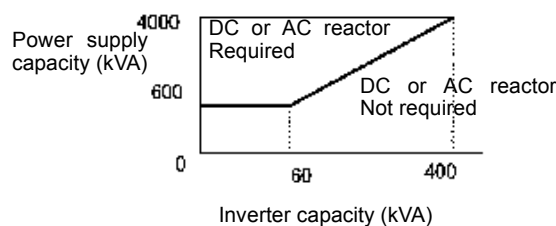

Fig 10.5

■ Inverter Capacity

When connecting special motors or multiple motors in parallel to an Inverter, select the Inverter capacity so that the rated output current of the Inverter is 1.1 times the sum of all the motor rated currents.

■ Initial Torque

The startup and acceleration characteristics of the motor are restricted by the overload current ratings of the Inverter that is driving the motor. The torque characteristics are generally less than those required when starting using a normal commercial power supply. If a large initial torque is required, select an Inverter with a somewhat larger capacity or increase the capacity of both the motor and the inverter.

■ Emergency Stop

Although the Inverter's protective functions will stop operation when a fault occurs, the motor will not stop immediately. Always provide mechanical stop and protection mechanisms on equipment requiring an emergency stop.

■ Options

Terminals B1, B2, ⊖, ⊕1, ⊕2, ⊕3 are for connecting only the options specifically provided by Yaskawa. Never connect any other devices to these terminals.

◆ Installation

Observe the following precautions when installing an Inverter.

■ Installation in Enclosures

Either install the Inverter in a clean location not subject to oil mist, airborne matter, dust, and other contaminants, or install the Inverter in a completely enclosed panel. Provide cooling measures and sufficient panel space so that the temperature surrounding the Inverter does not go beyond the allowable temperature. Do not install the Inverter on wood or other combustible materials.

■ Installation Direction

Mount the Inverter vertically to a wall or other horizontal surface.

◆ Settings

Observe the following precautions when making settings for an Inverter.

■ Upper Limits

The Digital Operator can be used to set high-speed operation up to a maximum of 400 Hz (depends on the carrier frequency). Incorrect settings can be dangerous. Use the maximum frequency setting functions to set upper limits. (The maximum output frequency is factory-set to 60 Hz.)

■ DC Injection Braking

The motor can overheat if the DC injection braking voltage or braking time is set to a large value.

■ Acceleration/Deceleration Times

The motor's acceleration and deceleration times are determined by the torque generated by the motor, the load torque, and the load's inertial moment ($GD^2/4$). If the stall prevention functions are activated during acceleration or deceleration, increase the acceleration or deceleration time. The stall prevention functions will increase the acceleration or deceleration time by the amount of time the stall prevention function is active.

To reduce the acceleration or deceleration times, increase the capacity of the motor and Inverter.

◆ Handling

Observe the following precautions when wiring or performing maintenance for an Inverter.

■ Wiring Check

The Inverter will be internally damaged if the power supply voltage is applied to output terminal U, V, or W. Check wiring for any mistakes before supplying power. Check all wiring and sequences carefully.

■ Magnetic Contactor Installation

Do not start and stop operation frequently with a magnetic contactor installed on the power supply line. Doing so can cause the Inverter to malfunction. Do not turn the Inverter ON and OFF with a magnetic contactor more than one time every 30 minutes.

■ Maintenance and Inspections

After turn OFF the main circuit power supply, always confirm that the CHARGE indicator is not lit before performing maintenance or inspections. The voltage remaining in the capacitor may cause electric shock.

Motor Application Precautions

This section provides precautions for motor application.

◆ Using the Inverter for an Existing Standard Motor

When a standard motor is operated with the Inverter, power loss is slightly higher than when operated with a commercial power supply. Observe the following precautions when using an Inverter for an existing standard motor.

■ Low Speed Ranges

Cooling effects diminish in the low-speed range, resulting in an increase in the motor temperature. Therefore, the motor torque should be reduced in the low-speed range whenever using a motor not made by Yaskawa. If 100% torque is required continuously at low speed, consider using a special inverter or vector motor.

■ Installation Withstand Voltage

If the input voltage is high (440 V or higher) or the wiring distance is long, the motor insulation voltage must be considered. Contact your Yaskawa representative for details.

■ High-speed Operation

When using the motor at a high speed (60 Hz or more), problems may arise in dynamic balance and bearing durability. Contact your Yaskawa representative for details.

■ Torque Characteristics

The motor may require more acceleration torque when the motor is operated with the Inverter than when operated with a commercial power supply. Check the load torque characteristics of the machine to be used with the motor to set a proper V/f pattern.

■ Vibration

The Inverter uses a high carrier PWM to reduce motor vibration. (A constant can be set to select low carrier, PWM modulation control as well.) When the motor is operated with the Inverter, motor vibration is almost the same as when operated with a commercial power supply.

Motor vibration may, however, become greater in the following cases.

Resonance with the Natural Frequency of the Mechanical System

Take special care when a machine that has been operated at a constant speed is to be operated in variable speed mode. If resonance occurs, install vibration-proof rubber on the motor base or use the frequency jump function to skip any frequency resonating the machine.

Imbalanced Rotor

Take special care when the motor is operated at a higher speed (60 Hz or more).

■ Noise

Noise varies with the carrier frequency. At high carrier frequencies, the noise is almost the same when the motor is operated with a commercial power supply. Motor noise, however, becomes louder when the motor is operated at a speed higher than the rated speed (60 Hz).

◆ Using the Inverter for Special Motors

Observe the following precautions when using a special motor.

■ Pole-changing Motor

The rated input current of pole-changing motors differs from that of standard motors. Select, therefore, an appropriate Inverter according to the maximum input current of the motor to be used. Before changing the number of poles, always make sure that the motor has stopped. Otherwise, the overvoltage protective or over-current protective mechanism will be actuated, resulting in an error.

■ Submersible Motor

The rated input current of submersible motors is higher than that of standard motors. Therefore, always select an Inverter by checking its rated output current. When the distance between the motor and Inverter is long, use a cable thick enough to connect the motor and Inverter to prevent motor torque reduction.

■ Explosion-proof Motor

When an explosion-proof motor is to be used, it must be subject to an explosion-proof test in conjunction with the Inverter. This is also applicable when an existing explosion-proof motor is to be operated with the Inverter. Since the Inverter itself is, however, not explosion-proof, always install it in a safe place.

■ Gearmotor

The speed range for continuous operation differs according to the lubrication method and motor manufacturer. In particular, continuous operation of an oil-lubricated motor in the low speed range may result in burning. If the motor is to be operated at a speed higher than 60 Hz, consult with the manufacturer.

■ Synchronous Motor

A synchronous motor is not suitable for Inverter control. If a group of synchronous motors is individually turned ON and OFF, synchronism may be lost.

■ Single-phase Motor

Do not use an Inverter for a single-phase motor. The motor should be replaced with a 3-phase motor.

◆ Power Transmission Mechanism (Speed Reducers, Belts, and Chains)

If an oil-lubricated gearbox or speed reducer is used in the power transmission mechanism, oil lubrication will be affected when the motor operates only in the low speed range. The power transmission mechanism will make noise and experience problems with service life and durability if the motor is operated at a speed higher than 60 Hz.

Conformance to CE Markings

Points regarding conformance to CE markings are given below.

◆ CE Markings

CE markings indicate conformance to safety and environmental standards that apply to business transactions (including production, imports, and sales) in Europe. There are unified European standards for mechanical products (Machine Directive), electrical products (Low Voltage Directive), and electrical noise (EMC Directive). CE markings are required for business transactions in Europe (including production, imports, and sales).

The Varispeed G7-Series Inverters bear CE markings indicating conformance to the Low Voltage Directive and the EMC Directive.

- Low Voltage Directive: 73/23/EEC
93/68/EEC
- EMC Directive: 89/336/EEC
92/31/EEC
93/68/EEC

Machinery and installations that incorporate the Inverter are also subject to CE markings. It is ultimately the responsibility of customers making products incorporating the Inverter to attach CE markings to the finished products. The customer must confirm that the finished products (machines or installations) conform to the European Standards.

◆ Requirements for Conformance to CE Markings

■ Low Voltage Directive

Varispeed G7-Series Inverters satisfy testing for conformance to the Low Voltage Directive under the conditions described in European Standard EN50178.

Requirements for Conformance to the Low Voltage Directive

Varispeed G7-Series Inverters must satisfy the following conditions in order to conform to the Low Voltage Directive.

- It must be used under conditions corresponding to overvoltage category 3 or less and pollution degree 2 or less as specified in IEC664.
- Input fuses:
For details on selecting fuses, refer to *Table 10.2 Selection Requirements for Input Fuses with Examples*.
- With Inverters CIMR-G7C2018 to 2110 and CIMR-G7C4018 to 4300, an enclosure preventing foreign matter from entering from the top or front sides is required (IP4X or higher: panel installation).

Input Fuses

In order to conform to the Low Voltage Directive, fuses must be provided for inputs. Use UL-compatible input fuses with ratings higher than the voltages and currents, and fusing I^2t specifications within the ranges shown in the table below.

Table 10.2 Selection Requirements for Input Fuses with Examples

Voltage Class	Inverter Model Number CIMR-G7C	Selection Requirements			Input Fuse (Examples)			
		Voltage (V)	Current (A)	Fusing I^2t (A ² sec)	Model Number	Manufacturer	Ratings	Fusing I^2t (A ² sec)
200 V class	20P4	240	10	12 to 25	A60Q12-2	FERRAZ	600 V 12 A	17
	20P7	240	15	23 to 55	CR2LS-20/UL	FUJI	250 V 20 A	27
	21P5	240	20	34 to 98	CR2LS-30/UL	FUJI	250 V 30 A	60
	22P2	240	30	82 to 220	CR2LS-50/UL	FUJI	250 V 50 A	200
	23P7	240	40	220 to 610	CR2LS-75/UL	FUJI	250 V 75 A	560
	25P5	240	50	290 to 1300	CR2LS-75/UL	FUJI	250 V 75 A	560
	27P5	240	60	450 to 5000	CR2LS-100/UL	FUJI	250 V 100 A	810
	2011	240	90	1200 to 7200	CR2L-125/UL	FUJI	250 V 125 A	1570
	2015	240	120	1800 to 7200	CR2L-150/UL	FUJI	250 V 150 A	2260
	2018	240	140	870 to 16200	CR2L-150/UL	FUJI	250 V 150 A	2260
	2022	240	160	1500 to 23000	CR2L-200/UL	FUJI	250 V 200 A	4010
	2030	240	220	2100 to 19000	CR2L-260/UL	FUJI	250 V 260 A	7320
	2037	240	270	2700 to 55000	CR2L-300/UL	FUJI	250 V 300 A	9630
	2045	240	300	4000 to 55000	CR2L-300/UL	FUJI	250 V 300 A	9630
	2055	240	370	7100 to 64000	CR2L-400/UL	FUJI	250 V 400 A	24000
	2075	240	500	11000 to 64000	CR2L-500/UL	FUJI	250 V 500 A	40000
	2090	240	600	13000 to 83000	CR2L-600/UL	FUJI	250 V 600 A	52000
2110	240	700	13000 to 83000	A50P700-4	FERRAZ	500 V 700 A	49000	

Table 10.2 Selection Requirements for Input Fuses with Examples

Voltage Class	Inverter Model Number CIMR-G7C	Selection Requirements			Input Fuse (Examples)			
		Voltage (V)	Current (A)	Fusing I^2t (A^2sec)	Model Number	Manufacturer	Rated	Fusing I^2t (A^2sec)
400 V class	40P4	480	5	16 to 660	CR6L-20/UL	FUJI	600 V 20 A	26
	40P7	480	10	19 to 660	CR6L-20/UL	FUJI	600 V 20 A	26
	41P5	480	10	46 to 660	CR6L-30/UL	FUJI	600 V 30 A	59
	42P2	480	15	78 to 660	CR6L-50/UL	FUJI	600 V 50 A	317
	43P7	480	20	110 to 660	CR6L-50/UL	FUJI	600 V 50 A	317
	44P0	480	25	220 to 660	CR6L-50/UL	FUJI	600 V 50 A	317
	45P5	480	30	240 to 900	CR6L-50/UL	FUJI	600 V 50 A	317
	47P5	480	40	320 to 900	CR6L-75/UL	FUJI	600 V 75 A	564
	4011	480	50	1000 to 1800	CR6L-100/UL	FUJI	600 V 100 A	1022
	4015	480	60	1500 to 4100	CR6L-150/UL	FUJI	600 V 150 A	3070
	4018	480	70	530 to 5800	CR6L-150/UL	FUJI	600 V 150 A	3070
	4022	480	90	1130 to 5800	CR6L-150/UL	FUJI	600 V 150 A	3070
	4030	480	110	1700 to 5800	CR6L-150/UL	FUJI	600 V 150 A	3070
	4037	480	140	2000 to 13000	CR6L-200/UL	FUJI	600 V 200 A	5200
	4045	480	160	3000 to 13000	CR6L-200/UL	FUJI	600 V 200 A	5200
	4055	480	220	6800 to 55000	CR6L-300/UL	FUJI	600 V 300 A	17700
	4075	480	300	3800 to 55000	CR6L-300/UL	FUJI	600 V 300 A	17700
	4090	480	330	12000 to 23000	A70P400-4	FERRAZ	700 V 400 A	19000
	4110	480	400	18000 to 64000	A70P450-4	FERRAZ	700 V 400 A	24000
	4132	480	450	28000 to 250000	A70P600-4	FERRAZ	700 V 600 A	43000
4160	480	540	40000 to 250000	A70P700-4	FERRAZ	700 V 700 A	59000	
4185	480	750	63000 to 400000	A70P900-4	FERRAZ	700 V 900 A	97000	
4220	480	750	63000 to 400000	A70P1000-4	FERRAZ	700 V 900 A	97000	
4300	480	1000	94000 to 920000	A70P1000-4	FERRAZ	700 V 1000 A	120000	

■ EMC Directive

Varispeed G7-Series Inverters satisfy testing for conformance to the EMC Directive under the conditions described in European Standard EN61800-3.

Installation Method

In order to ensure that the machinery or installation incorporating the Inverter conforms to the EMC Directive, perform installation according to the method below.

- Install a noise filter that conforms to European Standards on the input side. (Refer to *Table 10.3 EMC Noise Filters*).
- Use a shielded line or metal piping for wiring between the Inverter and Motor. Make the wiring as short as possible.
- To suppress harmonics, install a DC reactor in CIMR-G7C20P4, 20P7, 40P4, and 40P7 models. (Refer to *Table 10.4 DC Reactors for Suppressing Harmonics*.)

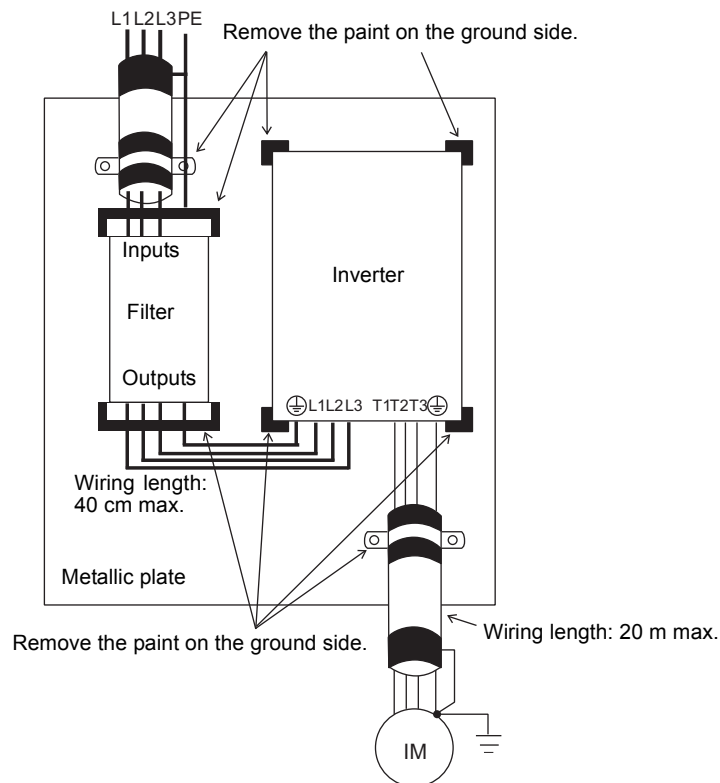

Fig 10.6 Installation Method for Filter and Inverter (CIMR-G7C20P4 to 2018, 40P4 to 4018)

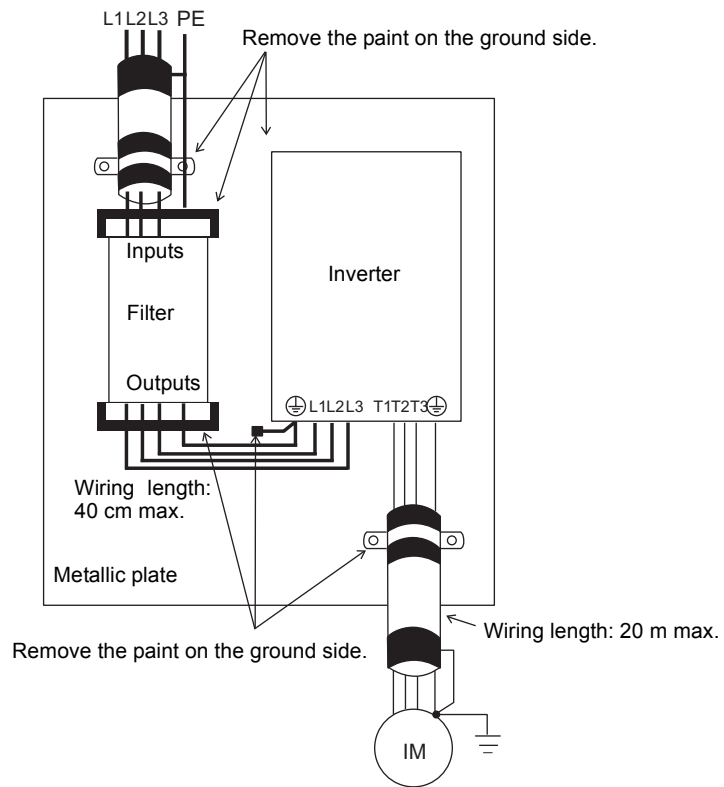

Fig 10.7 Installation Method for Filter and Inverter (CIMR-G7C2022 to 2110, 4022 to 4300)

Table 10.3 EMC Noise Filters

Voltage Class	Inverter Model Number CIMR-G7C	Noise Filter (Made by Schaffner)			
		Model Number	Rated Current (A)	Weight (kg)	Dimensions
200 V class	20P4	FS 5972-10-07	10	1.1	141 x 330 x 46
	20P7				
	21P5	FS 5972-18-07	18	1.3	141 x 330 x 46
	22P2	FS 5972-35-07	35	1.4	141 x 330 x 46
	23P7				
	25P5	FS 5972-60-07	60	3	206 x 355 x 60
	27P5				
	2011	FS 5972-100-07	100	4.9	236 x 408 x 80
	2015				
	2018				
	2022	FS 5972-120-35	120	4.3	90 x 366 x 180
	2030	FS 5972-180-40	180	6	120 x 451 x 170
	2037				
	2045	FS 5972-300-37	300	11	130 x 610 x 240
	2055				
	2075	FS 5972-300-37	360	11	130 x 610 x 240
	2090	FS 5972-300-37	450	11	130 x 610 x 240
2110					

Table 10.3 EMC Noise Filters

Voltage Class	Inverter Model Number CIMR-G7C	Noise Filter (Made by Schaffner)			
		Model Number	Rated Current (A)	Weight (kg)	Dimensions
400 V class	40P4	Under development	---	---	---
	40P7				
	41P5	Under development	---	---	---
	42P2				
	43P7				
	44P0				
	45P5	Under development	---	---	---
	47P5				
	4011	Under development	---	---	---
	4015				
	4018	Under development	---	---	---
	4022				
	4030	Under development	---	---	---
	4037				
	4045				
	4055	Under development	---	---	---
	4075				
	4090	Under development	---	---	---
	4110				
	4132	Under development	---	---	---
4160	Under development	---	---	---	
4185	Under development	---	---	---	
4220	Under development	---	---	---	
4300	Under development	---	---	---	

Table 10.4 DC Reactors for Suppressing Harmonics

Voltage Class	Inverter Model Number CIMR-G7C	DC Reactor			
		Model Number	Manufacturer	Ratings	Code Number
200 V class	20P4	UZDA-B	YASKAWA	5.4 A 8 mH	X010084
	20P7				
400 V class	40P4	UZDA-B	YASKAWA	3.2 A 28 mH	X010052
	40P7				

User Constants

Factory settings are given in the following table. These setting are for a 200 V Class Inverter of 0.4 kW set to factory set control method (open-loop vector control).

Table 10.5 User Constants

No.	Name	Factory Setting	Setting	No.	Name	Factory Setting	Setting
A1-00	Language selection for digital operator display	1*1		b5-11	PID reverse output selection	0	
A1-01	Constant access level	2		b5-12	Selection of PID feedback command loss detection	0	
A1-02	Control method selection	2*1		b5-13	PID feedback command loss detection level	0	
A1-03	Initialize	0		b5-14	PID feedback command loss detection time	1.0	
A1-04	Password	0		b5-15	PID sleep function operation level	0.0	
A1-05	Password setting	0		b5-16	PID sleep operation delay time	0.0	
A2-01 to A2-32	User setting constants	-		b5-17	Acceleration/deceleration time for PID reference	0.0	
b1-01	Reference selection	1		b6-01	Dwell frequency at start	0.0	
b1-02	Operation method selection	1		b6-02	Dwell time at start	0.0	
b1-03	Stopping method selection	0		b6-03	Dwell frequency at stop	0.0	
b1-04	Prohibition of reverse operation	0		b6-04	Dwell time at stop	0.0	
b1-05	Operation selection for setting E1-09 or less	0		b7-01	Droop control gain	0.0	
b1-06	Read sequence input twice	1		b7-02	Droop control delay time	0.05	
b1-07	Operation selection after switching to remote mode	0		b8-01	Energy-saving mode selection	0	
b1-08	Run command selection in programming modes	0		b8-02	Energy-saving gain	0.7*4	
b2-01	Zero speed level (DC injection braking starting frequency)	0.5		b8-03	Energy-saving filter time constant	0.50*5	
b2-02	DC injection braking current	50		b8-04	Energy-saving coefficient	*6	
b2-03	DC injection braking time at start	0.00		b8-05	Power detection filter time constant	20	
b2-04	DC injection braking time at stop	0.50		b8-06	Search operation voltage limiter	0	
b2-08	Magnetic flux compensation volume	0		b9-01	Zero-servo gain	5	
b3-01	Speed search selection	2*2 *3		b9-02	Zero-servo completion width	10	
b3-02	Speed search operating current	100*2		C1-01	Acceleration time 1	10.0	
b3-03	Speed search deceleration time	2.0		C1-02	Deceleration time 1	10.0	
b3-05	Speed search wait time	0.2		C1-03	Acceleration time 2	10.0	
b4-01	Timer function ON-delay time	0.0		C1-04	Deceleration time 2	10.0	
b4-02	Timer function OFF-delay time	0.0		C1-05	Acceleration time 3	10.0	
b5-01	PID control mode selection	0		C1-06	Deceleration time 3	10.0	
b5-02	Proportional gain (P)	1.00		C1-07	Acceleration time 4	10.0	
b5-03	Integral (I) time	1.0		C1-08	Deceleration time 4	10.0	
b5-04	Integral (I) limit	100.0		C1-09	Emergency stop time	10.0	
b5-05	Derivative (D) time	0.00		C1-10	Accel/decel time setting unit	1	
b5-06	PID limit	100.0		C1-11	Accel/decel time switching frequency	0.0	
b5-07	PID offset adjustment	0.0		C2-01	S-curve characteristic time at acceleration start	0.20	
b5-08	PID primary delay time constant	0.00		C2-02	S-curve characteristic time at acceleration end	0.20	
b5-09	PID output characteristics selection	0		C2-03	S-curve characteristic time at deceleration start	0.20	
b5-10	PID output gain	1.0		C2-04	S-curve characteristic time at deceleration end	0.00	

Table 10.5 User Constants (Continued)

No.	Name	Factory Setting	Setting	No.	Name	Factory Setting	Setting
C3-01	Slip compensation gain	1.0 ^{*3}		d3-01	Jump frequency 1	0.0	
C3-02	Slip compensation primary delay time	200 ^{*2}		d3-02	Jump frequency 2	0.0	
C3-03	Slip compensation limit	200		d3-03	Jump frequency 3	0.0	
C3-04	Slip compensation selection during regeneration	0		d3-04	Jump frequency width	1.0	
C3-05	Output voltage limit operation selection	0		d4-01	Frequency reference hold function selection	0	
C4-01	Torque compensation gain	1.00		d4-02	+ - Speed limits	10	
C4-02	Torque compensation primary delay time constant	20 ^{*2*3}		d5-01	Torque control selection	0	
C4-03	Forward starting torque	0.0		d5-02	Torque reference delay time	0	
C4-04	Reverse starting torque	0.0		d5-03	Speed limit selection	1	
C4-05	Starting torque time constant	10		d5-04	Speed limit	0	
C5-01	ASR proportional gain 1	20.00		d5-05	Speed limit bias	10	
C5-02	ASR integral (I) time 1	0.500		d5-06	Speed/torque control switching timer	0	
C5-03	ASR proportional gain 2	20.00		d6-01	Field weakening level	80	
C5-04	ASR integral (I) time 2	0.500		d6-02	Field frequency	0.0	
C5-05	ASR limit	5.0		d6-03	Field forcing function selection	0	
C5-06	ASR primary delay time	0.004		d6-05	AφR time constant	1.00	
C5-07	ASR switching frequency	0.0		E1-01	Input voltage setting	200 ^{*7}	
C5-08	ASR integral (I) limit	400		E1-03	V/f pattern selection	F	
C6-02	Carrier frequency selection	6 ^{*6}		E1-04	Max. output frequency	60.0	
C6-03	Carrier Frequency Upper Limit	15.0 ^{*6}		E1-05	Max. voltage	200.0 ^{*2 *7}	
C6-04	Carrier Frequency Lower Limit	15.0 ^{*6}		E1-06	Base frequency	60.0 ^{*2}	
C6-05	Carrier Frequency Proportional Gain	00		E1-07	Mid. output frequency	3.0 ^{*2}	
C6-11	Carrier frequency for open-loop vector control 2	4		E1-08	Mid. output frequency voltage	15.0 ^{*2 *7}	
d1-01	Frequency reference 1	0.00		E1-09	Min. output frequency	1.5 ^{*2}	
d1-02	Frequency reference 2	0.00		E1-10	Min. output frequency voltage	9.0 ^{*2 *7}	
d1-03	Frequency reference 3	0.00		E1-11	Mid. output frequency 2	0.0 ^{*9}	
d1-04	Frequency reference 4	0.00		E1-12	Mid. output frequency voltage 2	0.0 ^{*9}	
d1-05	Frequency reference 5	0.00		E1-13	Base voltage	0.0 ^{*10}	
d1-06	Frequency reference 6	0.00		E2-01	Motor rated current	1.90 ^{*6}	
d1-07	Frequency reference 7	0.00		E2-02	Motor rated slip	2.90 ^{*6}	
d1-08	Frequency reference 8	0.00		E2-03	Motor no-load current	1.20 ^{*6}	
d1-09	Frequency reference 9	0.00		E2-04	Number of motor poles	4	
d1-10	Frequency reference 10	0.00		E2-05	Motor line-to-line resistance	9.842 ^{*6}	
d1-11	Frequency reference 11	0.00		E2-06	Motor leak inductance	18.2 ^{*6}	
d1-12	Frequency reference 12	0.00		E2-07	Motor iron saturation coefficient 1	0.50	
d1-13	Frequency reference 13	0.00		E2-08	Motor iron saturation coefficient 2	0.75	
d1-14	Frequency reference 14	0.00		E2-09	Motor mechanical loss	0.0	
d1-15	Frequency reference 15	0.00		E2-10	Motor iron loss for torque compensation	14 ^{*4}	
d1-16	Frequency reference 16	0.00		E2-11	Motor rated output	0.40 ^{*4}	
d1-17	Jog frequency reference	6.00		E3-01	Motor 2 control method selection	2	
d2-01	Frequency reference upper limit	100.0		E3-02	Motor 2 max. output frequency (FMAX)	60.0 ^{*2}	
d2-02	Frequency reference lower limit	0.0		E3-03	Motor 2 max. voltage (VMAX)	200.0 ^{*2}	
d2-03	Master speed reference lower limit	0.0		E3-04	Motor 2 max. voltage frequency (FA)	60.0	

Table 10.5 User Constants (Continued)

No.	Name	Factory Setting	Setting	No.	Name	Factory Setting	Setting
E3-05	Motor 2 mid. output frequency 1 (FB)	3.0 *2		F4-08	Analog output signal level for channel 2	0	
E3-06	Motor 2 mid. output frequency voltage 1 (VC)	11.0 *7		F5-01	Channel 1 output selection	0	
E3-07	Motor 2 min. output frequency (FMIN)	0.5 *2		F5-02	Channel 2 output selection	1	
E3-08	Motor 2 min. output frequency voltage (VMIN)	2.0 *7		F5-03	Channel 3 output selection	2	
E4-01	Motor 2 rated current	1.90 *6		F5-04	Channel 4 output selection	4	
E4-02	Motor 2 rated slip	2.90 *6		F5-05	Channel 5 output selection	6	
E4-03	Motor 2 no-load current	1.20 *6		F5-06	Channel 6 output selection	37	
E4-04	Motor 2 number of poles (number of poles)	4		F5-07	Channel 7 output selection	0F	
E4-05	Motor 2 line-to-line resistance	9.842 *6		F5-08	Channel 8 output selection	0F	
E4-06	Motor 2 leak inductance	18.2 *6		F5-09	DO-08 output mode selection	0	
E4-07	Motor 2 rated capacity	0.40 *6		F6-01	Operation selection after communications error	1	
F1-01	PG constant	600		F6-02	Input level of external fault from Communications Option Card	0	
F1-02	Operation selection at PG open circuit (PGO)	1		F6-03	Stopping method for external fault from Communications Option Card	1	
F1-03	Operation selection at overspeed (OS)	1		F6-04	Trace sampling from Communications Option Card	0	
F1-04	Operation selection at deviation	3		F6-06	Torque reference/torque limit selection from optical option	1	
F1-05	PG rotation	0		H1-01	Terminal S3 function selection	24	
F1-06	PG division rate (PG pulse monitor)	1		H1-02	Terminal S4 function selection	14	
F1-07	Integral value during accel/decel enable/disable	0		H1-03	Terminal S5 function selection	3 (0) *8	
F1-08	Overspeed detection level	115		H1-04	Terminal S6 function selection	4 (3) *8	
F1-09	Overspeed detection delay time	0.0		H1-05	Terminal S7 function selection	6 (4) *8	
F1-10	Excessive speed deviation detection level	10		H1-06	Terminal S8 function selection	8 (6)	
F1-11	Excessive speed deviation detection delay time	0.5		H1-07	Terminal S9 function selection	5	
F1-12	Number of PG gear teeth 1	0		H1-08	Terminal S10 function selection	32	
F1-13	Number of PG gear teeth 2	0		H1-09	Terminal S11 function selection	7	
F1-14	PG open-circuit detection time	2.0		H1-10	Terminal S12 function selection	15	
F2-01	Bi-polar or uni-polar input selection	0		H2-01	Terminal M1-M2 function selection (contact)	0	
F3-01	Digital input option	0		H2-02	Terminal M3-M4 function selection (open collector)	1	
F4-01	Channel 1 monitor selection	2		H2-03	Terminal M5-M6 function selection (open collector)	2	
F4-02	Channel 1 gain	1.00		H2-04	Terminal P3 function selection (open-collector)	6	
F4-03	Channel 2 monitor selection	3		H2-05	Terminal P4 function selection (open-collector)	5	
F4-04	Channel 2 gain	0.50		H3-01	Signal level selection (terminal A1)	0	
F4-05	Channel 1 output monitor bias	0.0		H3-02	Gain (terminal A1)	0	
F4-06	Channel 2 output monitor bias	0.0		H3-03	Bias (terminal A1)	100.0	
F4-07	Analog output signal level for channel 1	0		H3-04	Signal level selection (terminal A3)	0	

Table 10.5 User Constants (Continued)

No.	Name	Factory Setting	Setting	No.	Name	Factory Setting	Setting
H3-05	Multi-function analog input (terminal A3)	2		L2-04	Voltage recovery time	0.3	
H3-06	Gain (terminal A3)	100.0		L2-05	Undervoltage detection level	190*7	
H3-07	Bias (terminal A3)	0.0		L2-06	KEB deceleration time	0.0	
H3-08	Multi-function analog input terminal A2 function selection	2		L2-07	Momentary recovery time	0*11	
H3-09	Multi-function analog input terminal A2 signal level selection	0		L2-08	Frequency reduction gain at KEB start	100	
H3-10	Gain (terminal A2)	100.0		L3-01	Stall prevention selection during accel	1	
H3-11	Bias (terminal A2)	0.0		L3-02	Stall prevention level during accel	150	
H3-12	Analog input filter time constant	0.03		L3-03	Stall prevention limit during accel	50	
H4-01	Monitor selection (terminal FM)	2		L3-04	Stall prevention selection during decel	1	
H4-02	Gain (terminal FM)	1.00		L3-05	Stall prevention selection during running	1	
H4-03	Bias (terminal FM)	0.0		L3-06	Stall prevention level during running	160	
H4-04	Monitor selection (terminal AM)	3		L4-01	Speed agreement detection level	0.0	
H4-05	Gain (terminal AM)	0.50		L4-02	Speed agreement detection width	2.0	
H4-06	Bias (terminal AM)	0.0		L4-03	Speed agreement detection level (+/-)	0.0	
H4-07	Analog output 1 signal level selection	0		L4-04	Speed agreement detection width (+/-)	2.0	
H4-08	Analog output 2 signal level selection	0		L4-05	Operation when frequency reference is missing	0	
H5-01	Station address	1F		L5-01	Number of auto restart attempts	0	
H5-02	Communication speed selection	3		L5-02	Auto restart operation selection	0	
H5-03	Communication parity selection	0		L6-01	Torque detection selection 1	0	
H5-04	Stopping method after communication error	3		L6-02	Torque detection level 1	150	
H5-05	Communication error detection selection	1		L6-03	Torque detection time 1	0.1	
H5-06	Send wait time	5		L6-04	Torque detection selection 2	0	
H5-07	RTS control ON/OFF	1		L6-05	Torque detection level 2	150	
H6-01	Pulse train input function selection	0		L6-06	Torque detection time 2	0.1	
H6-02	Pulse train input scaling	1440		L7-01	Forward drive torque limit	200	
H6-03	Pulse train input gain	100.0		L7-02	Reverse drive torque limit	200	
H6-04	Pulse train input bias	0.0		L7-03	Forward regenerative torque limit	200	
H6-05	Pulse train input filter time	0.10		L7-04	Reverse regenerative torque limit	200	
H6-06	Pulse train monitor selection	2		L8-01	Protect selection for internal DB resistor (Type ERF)	0	
H6-07	Pulse train monitor scaling	1440		L8-02	Overheat pre-alarm level	95	
L1-01	Motor protection selection	1		L8-03	Operation selection after overheat pre-alarm	3	
L1-02	Motor protection time constant	1.0		L8-05	Input open-phase protection selection	0	
L1-03	Alarm operation selection during motor overheating	3		L8-07	Output open-phase protection selection	0	
L1-04	Motor overheating operation selection	1		L8-09	Ground protection selection	1	
L1-05	Motor temperature input filter time constant	0.20		L8-10	Cooling fan control selection	0	
L2-01	Momentary power loss detection	0		L8-11	Cooling fan control delay time	60	
L2-02	Momentary power loss ridethru time	0.1*6		L8-12	Ambient temperature	45	
L2-03	Min. baseblock time	0.5		L8-15	OL2 characteristics selection at low speeds	1	

Table 10.5 User Constants (Continued)

No.	Name	Factory Setting	Setting	No.	Name	Factory Setting	Setting
L8-18	Soft CLA selection	1		o2-01	LOCAL/REMOTE key enable/disable	1	
N1-01	Hunting-prevention function selection	1		o2-02	STOP key during control circuit terminal operation	1	
N1-02	Hunting-prevention gain	1.00		o2-03	User constant initial value	0	
N2-01	Speed feedback detection control (AFR) gain	1.00		o2-04	kVA selection	0 ^{*6}	
N2-02	Speed feedback detection control (AFR) time constant	50		o2-05	Frequency reference setting method selection	0	
N2-03	Speed feedback detection control (AFR) time constant 2	750		o2-06	Operation selection when digital operator is disconnected	0	
N3-01	High-slip braking deceleration frequency width	5		o2-07	Cumulative operation time setting	0	
N3-02	High-slip braking current limit	150		o2-08	Cumulative operation time selection	0	
N3-03	High-slip braking stop dwell time	1.0		o2-10	Fan operation time setting	0	
N3-04	High-slip braking OL time	40		o2-12	Fault trace/fault history clear function	0	
N4-07	Integral time of speed estimator	0.100		o3-01	Copy function selection	0	
N4-08	Proportional gain of speed estimator	15		o3-02	Read permitted selection	0	
N4-17	Torque adjustment gain	0.8		T1-00	Motor 1/2 selection	1	
N4-18	Feeder resistance adjustment gain	1.00		T1-01	Autotuning mode selection	0	
N5-01	Feed forward control selection	0		T1-02	Motor output power	0.40	
N5-02	Motor acceleration time	0.178		T1-03	Motor rated voltage	200.0 ^{*7}	
N5-03	Feed forward proportional gain	1.0		T1-04	Motor rated current	1.90 ^{*6}	
o1-01	Monitor selection	6		T1-05	Motor base frequency	60.00	
o1-02	Monitor selection after power up	1		T1-06	Number of motor poles	4	
o1-03	Frequency units of reference setting and monitor	0		T1-07	Motor base speed	1750	
o1-04	Setting unit for frequency constants related to V/f characteristics	0		T1-08	PG pulses per revolution for teaching	600	
o1-05	LCD brightness adjustment	3					

* 1. Not initialized. (Japanese standard specifications: A1-01 = 1, A1-02 = 2)

* 2. The factory setting will change if the control method is changed. The factory settings given above are for V/f without PG control.

* 3. Factory setting depends on the control method (A1-02).

* 4. For V/f with PG control: 1.0

* 5. For Inverters with a capacity of 55 kW or more: 2.00

* 6. Setting range and initial setting depend on Inverter capacity.

* 7. Setting for 200 V class Inverters. For 400 V class Inverters, double the value.

* 8. Factory setting in the parentheses is for 3-wire sequence.

* 9. The contents is ignored if the setting is 0.0.

* 10. E1-13 will have the same value as E1-05 after autotuning.

* 11. If the set value is 0, acceleration will be to the speeds for the acceleration times (C1-01 to C1-08)

* 12. The setting range is 10% to 200% of the Inverter rated output. (The value given is for a 200 V Class Inverter for 0.4 kW.)

Symbols

+/- speed, 6-72

Numerics

2-wire sequence, 6-7

3-wire sequence, 6-8

A

AC reactor, 2-15

acceleration and deceleration times, 6-15

advanced programming mode, 3-4, 3-9

ASIC internal RAM fault, 7-8

ASIC version fault, 7-8

auto restart, 6-63

autotuning, 4-9

autotuning mode, 3-4, 3-13

B

baseblock circuit error, 7-7

braking resistor, 2-19

braking resistor unit, 2-19

BUS Option Com Err, 7-7, 7-12

C

CALL Com Call, 7-12

CE MEMOBUS Com Err, 7-11

CE Memobus Com Err, 7-6

CF out of control, 7-5

circuit breaker, 2-14

common specifications, 9-4

communications on standby, 7-12

communications option card A/D converter error, 7-8

communications option card DPRAM error, 7-8

communications option card model code error, 7-8

communications option card self diagnostic error, 7-8

constant selection error, 7-13

constant setting error, 7-14

constant setting range error, 7-13

control circuit terminals, 2-20

control fault, 7-5

control method, 4-8

control method selection error, 7-13

control power fault, 7-3

cooling fin overheating, 7-3

CPF00 CPF, 7-7

CPF01 CPF01, 7-7

CPU internal A/D converter error, 7-7

CPU-ASIC mutual diagnosis fault, 7-8

crimp terminals, 2-6, 2-20, 2-36

D

daily inspection, 8-2

DC reactor, 2-15

detecting motor overspeed, 6-145

detecting motor torque, 6-44

detecting PG open circuit, 6-145

DEV Speed Deviation, 7-10

digital operator, 3-2

digital operator communications error 1, 7-7

digital operator communications error 2, 7-7

digital operator connection fault, 7-6

digital output cards, 6-146

drive mode, 3-4, 3-6

dwel function, 6-19

E

EEPROM error, 7-7

EEPROM write error, 7-14

EF External Fault, 7-9

EF0 Opt External Flt, 7-6, 7-10

emergency stop, 6-14

enclosed wall-mounted type, 1-4

ERR EEPROM R/W Err, 7-14

excessive speed deviation, 7-5, 7-10

external fault function, 6-75

F

FBL Feedback Loss, 7-5, 7-11

FJOG, 6-74

forward/reverse run commands input together, 7-9

frequency reference, 6-2, 6-24

fuse blown, 7-2

G

ground fault, 7-2
ground fault interrupter, 2-14
ground wiring, 2-18

H

high-slip braking OL, 7-4
hunting-prevention function, 6-36

I

incorrect inverter capacity setting, 7-13
inductive noise, 2-17
inrush prevention circuit fault, 7-3
installation site, 1-9
installed braking resistor overheating, 7-4
internal braking transistor fault, 7-4
inverter input voltage, 6-108
inverter overload, 7-4
inverter's cooling fan stopped, 7-3

J

jump frequency function, 6-27

L

limiting motor rotation direction, 6-54
loaded operation, 4-14

M

magnetic contactor, 2-15
main circuit overvoltage, 7-2
main circuit undervoltage, 7-3, 7-9
main circuit voltage fault, 7-3
maintenance and inspection, 8-1
MEMOBUS communications, 6-81
MEMOBUS communications error, 7-6, 7-11
modes, 3-4
motor constants, 6-105
motor overheating, 7-9
motor overheating alarm, 7-3
motor overheating fault, 7-3

motor overload, 7-4
motor protection operation time, 6-51
mounting dimensions, 1-7
multi-function analog input, 6-41
multi-function analog input selection error, 7-13
multi-function input selection error, 7-13
multi-speed operation, 6-5

N

noise filter, 2-15
no-load operation, 4-14
number of gear teeth between PG and motor, 6-145
number of PG pulses, 6-144

O

OH Heatsink Overtemp, 7-9
OH2 Over Heat 2, 7-9
OH3 Motor Overheat 1, 7-9
OL3 Overtorque Det 1, 7-9
OL4 Overtorque Det 2, 7-10
OPE01 kVA Selection, 7-13
OPE011 Carr Freq/On-Delay, 7-14
OPE02 Limit, 7-13
OPE03 Terminal, 7-13
OPE05 Sequence Select, 7-13
OPE06 PG Opt Missing, 7-13
OPE07 Analog Selection, 7-13
OPE08, 7-13
OPE09, 7-13
OPE10 V/f Ptrn Setting, 7-13
open chassis type, 1-4
open-loop vector control, 4-9
operation errors, 7-13
OPR Oper Disconnect, 7-6
option card communications error, 7-12
option card connection error, 7-7
option card selection error, 7-13
option communications error, 7-7
OS Overspeed Det, 7-10
output open-phase, 7-3
OV DC Bus Overvolt, 7-9
overcurrent, 7-2
overspeed, 7-5, 7-10

overtorque 2, 7-10
overtorque detected 1, 7-4
overtorque detected 2, 7-4

P

password, 4-15, 6-140
periodic inspection, 8-2
periodic maintenance of parts, 8-3
PG (encoder) pulses, 2-37
PG disconnection, 7-10
PG disconnection detected, 7-5
PG pulse monitor output dividing ratio, 6-145
PG rotation direction, 6-144
PG speed control card, 6-144
PG speed control cards, 2-29
PGO PG Open, 7-10
PID control, 6-94
PID control selection error, 7-13
PID feedback reference lost, 7-5, 7-11
power ON, 4-3

Q

quick programming mode, 3-4, 3-7

R

radio interference, 2-18
rated current, 6-50
RJOG, 6-74
run command, 6-7

S

S-curve characteristics, 6-18
slip compensation function, 6-32
speed control with PG, 6-142
stabilizing speed, 6-37
stall prevention function, 6-20, 6-22, 6-44
standard connection diagrams, 2-13
standard inverter specifications, 9-2
stopping methods, 6-9
straight solderless terminals, 2-21, 2-36
surge absorber, 2-15

switching motors when the power supply is ON, 6-133

T

terminal block, 2-5
thermal overload relay, 2-17
tightening torque, 2-36
timer function, 6-93
torque compensation, 6-34
torque limit function, 6-41
trial operation, 4-1
troubleshooting, 7-1, 7-17

U

UL3 Undertorq Det 1, 7-10
UL4 Undertorq Det 2, 7-10
undertorque 1, 7-10
undertorque 2, 7-10
undertorque detected 1, 7-4
undertorque detected 2, 7-5
user constant access levels, 4-15
UV DC Bus Undervolt, 7-9

V

V/f control, 4-8
V/f control with PG, 4-8
V/f pattern, 6-107, 6-108
verify mode, 3-4, 3-12

W

watchdog timer fault, 7-8
wire size, 2-20
wiring, 2-1

