

VARISPEED E7

Variable Torque Frequency Inverter

USER'S MANUAL



Table of Content

Warnings	VII
Safety Precautions and Instructions for Use.....	VIII
EMC Compatibility	X
Line Filters	XII
Registered Trademarks.....	XV
1 Handling Inverters	1-1
Varispeed E7 Introduction	1-2
◆ Varispeed E7 Applications	1-2
◆ Varispeed E7 Models	1-2
Confirmations upon Delivery	1-4
◆ Checks	1-4
◆ Nameplate Information	1-4
◆ Inverter Software Version	1-5
◆ Component Names	1-6
Exterior and Mounting Dimensions	1-9
◆ IP00 Inverters	1-9
◆ NEMA 1 / IP20 Inverters	1-10
◆ IP54 Inverters	1-10
Checking and Controlling the Installation Site	1-13
◆ Installation Site	1-13
◆ Controlling the Ambient Temperature	1-13
◆ Protecting the IP00 or NEMA 1 Inverter from Foreign Matter	1-13
◆ Additional Installation Precautions for the IP54 Inverters	1-14
◆ Keeping the IP54 protection	1-14
Installation Orientation and Space	1-15
Accessing the Inverter Terminals	1-16
◆ Removing the Terminal Cover (IP00 and NEMA 1 / IP20 Inverters)	1-16
◆ Attaching the Terminal Cover	1-16
◆ Opening the Door (IP54 Inverters)	1-17
◆ Closing the Door (IP54 Inverters)	1-17
Removing/Attaching the Digital Operator and Front Cover	1-18
◆ Inverters of 18.5 kW or Less	1-18
◆ Inverters of 22 kW or More	1-20
2 Wiring.....	2-1
Connection Diagrams	2-2
◆ Circuit Descriptions	2-4
Terminal Block Configuration	2-5
Wiring Main Circuit Terminals	2-7
◆ Applicable Wire Sizes and Crimp Terminals	2-7
◆ Main Circuit Terminal Functions	2-15
◆ Main Circuit Configurations	2-16
◆ Standard Connection Diagrams	2-18
◆ Wiring the Main Circuits	2-20

Wiring Control Circuit Terminals	2-27
◆ Wire Sizes	2-27
◆ Control Circuit Terminal Functions	2-31
◆ Control Circuit Terminal Connections	2-35
◆ Control Circuit Wiring Precautions	2-36
Wiring Check	2-37
◆ Checks	2-37
Installing and Wiring Option Cards	2-38
◆ Option Card Models	2-38
◆ Installation in IP00 and NEMA 1 / IP20 Inverters	2-38
◆ Installation in IP54 Inverters	2-39
3 Digital Operator and Modes.....	3-1
Digital Operator	3-2
◆ Digital Operator Display	3-2
◆ Digital Operator Keys	3-3
Modes	3-5
◆ Inverter Modes	3-5
◆ Switching Modes	3-6
◆ Drive Mode	3-8
◆ Quick Programming Mode	3-9
◆ Advanced Programming Mode	3-11
◆ Verify Mode	3-15
◆ Autotuning Mode	3-17
4 Trial Operation	4-1
Trial Operation Procedure	4-2
Trial Operation	4-3
◆ Application Confirmation	4-3
◆ Setting the Power Supply Voltage Jumper (400 V Class Inverters of 75 kW or Higher)	4-3
◆ Power ON	4-3
◆ Checking the Display Status	4-4
◆ Basic Settings	4-5
◆ Selecting the V/f pattern	4-7
◆ Autotuning	4-7
◆ Application Settings	4-9
◆ No-load Operation	4-9
◆ Loaded Operation	4-9
◆ Check and Recording User Parameters	4-10
Adjustment Suggestions	4-11
5 User Parameters	5-1
User Parameter Descriptions	5-2
◆ Description of User Parameter Tables	5-2
Digital Operation Display Functions and Levels	5-3
◆ User Parameters Available in Quick Programming Mode	5-4

User Parameter Tables	5-6
◆ Setup Settings: A	5-6
◆ Application Parameters: b	5-8
◆ Tuning Parameters: C	5-15
◆ Reference Parameters: d	5-18
◆ Motor Parameters: E	5-20
◆ Option Parameters: F	5-22
◆ Terminal Function Parameters: H	5-23
◆ Protection Function Parameters: L	5-29
◆ Special Adjustments: n	5-35
◆ Digital Operator Parameters: o	5-36
◆ Motor Autotuning: T	5-40
◆ Monitor Parameters: U	5-41
◆ Setting Values that Change with the V/f Pattern Selection (E1-03)	5-46
◆ Factory Settings that Change with the Inverter Capacity (o2-04)	5-47

6 Parameter Settings by Function..... 6-1

Carrier Frequency Selection	6-2
◆ Setting the Carrier Frequency	6-2
Frequency Reference	6-5
◆ Selecting the Frequency Reference Source	6-5
◆ Using Multi-Step Speed Operation	6-7
Run Command	6-9
◆ Selecting the Run Command Source	6-9
Stopping Methods	6-11
◆ Selecting the Stopping Method when a Stop Command is Input	6-11
◆ Using the DC Injection Brake	6-13
◆ Using an Emergency Stop	6-14
Acceleration and Deceleration Characteristics	6-15
◆ Setting Acceleration and Deceleration Times	6-15
◆ Preventing the Motor from Stalling During Acceleration (Stall Prevention During Acceleration Function)	6-17
◆ Stall Prevention During Deceleration Function	6-19
Adjusting Frequency References	6-21
◆ Adjusting Analog Frequency References	6-21
◆ Jump Frequency Function (Operation Avoiding Resonance)	6-23
Speed Limit (Frequency Reference Limit Function)	6-24
◆ Limiting Maximum Output Frequency	6-24
◆ Limiting Minimum Frequency	6-24
Frequency Detection	6-25
◆ Speed Agreement Function	6-25
Improved Operating Performance	6-27
◆ Torque Compensation for Sufficient Torque at Start and Low-speed Operation	6-27
◆ Hunting Prevention Function	6-28
Machine Protection	6-29
◆ Preventing Motor Stalling During Operation	6-29
◆ Load Detection	6-30
◆ Motor Overload Protection	6-33

◆ Motor Overheat Protection Using PTC Thermistor Inputs	6-35
◆ Limiting Motor Rotation Direction and Output Phase Rotation	6-37
Automatic Restart	6-38
◆ Restarting Automatically After Momentary Power Loss	6-38
◆ Speed Search	6-39
◆ Continuing Operation at Constant Speed When Frequency Reference Is Lost	6-44
◆ Restarting Operation After Transient Fault (Auto Restart Function)	6-45
Inverter Protection	6-47
◆ Inverter Overheat Protection	6-47
◆ Input Phase Loss Detection Level	6-48
◆ Ground Fault Protection	6-48
◆ Cooling Fan Control	6-49
◆ Setting the Ambient Temperature	6-49
◆ OL2 Characteristics at Low Speed	6-50
◆ Soft CLA Selection	6-51
Input Terminal Functions	6-52
◆ Temporarily Switching Operation between Digital Operator and Control Circuit Terminals	6-52
◆ Blocking the Inverter Output (Baseblock Command)	6-53
◆ Multifunction Analog Input A2 Disable/Enable	6-53
◆ Drive Enable/Disable	6-54
◆ Bypass Drive Enable	6-54
◆ Stopping Acceleration and Deceleration (Acceleration/Deceleration Ramp Hold)	6-54
◆ Raising and Lowering Frequency References Using Digital Input Signals (UP/DOWN)	6-55
◆ Trim Control Function	6-58
◆ Analog Frequency Reference Sample/Hold	6-59
◆ Switching Operation Source to Communication Option Card	6-60
◆ Switching Operation Source to MEMOBUS communication	6-60
◆ AUTO/HAND Mode Switching by Digital Input	6-61
◆ Jog Frequency Operation without Forward and Reverse Commands (FJOG/RJOG)	6-62
◆ Stopping the Inverter on External Faults (External Fault Function)	6-63
Output Terminal Functions	6-64
Monitor Parameters	6-67
◆ Using the Analog Monitor Parameters	6-67
Individual Functions	6-69
◆ Using MEMOBUS Communications	6-69
◆ Using the Timer Function	6-86
◆ Using PI Control	6-87
◆ Energy-saving	6-98
◆ Setting Motor Parameters	6-99
◆ Setting the V/f Pattern	6-100
◆ Motor Preheat Function	6-106
◆ Emergency Override Function	6-108
◆ High Slip Braking	6-109
Digital Operator Functions	6-110
◆ Setting Digital Operator Functions	6-110
◆ Copying Parameters	6-113
◆ Prohibiting Writing Parameters from the Digital Operator	6-117
◆ Setting a Password	6-117
◆ Displaying User-set Parameters Only	6-118

7	Troubleshooting	7-1
	Protective and Diagnostic Functions	7-2
	◆ Fault Detection	7-2
	◆ Alarm Detection	7-8
	◆ Operator Programming Errors	7-11
	◆ Autotuning Faults	7-13
	◆ Digital Operator Copy Function Faults	7-13
	Troubleshooting	7-15
	◆ If Parameters Cannot Be Set	7-15
	◆ If the Motor Does Not Operate	7-16
	◆ If the Direction of the Motor Rotation is Reversed	7-17
	◆ If the Motor Does Not Put Out Torque or If Acceleration is Slow	7-17
	◆ If the Motor Operates at Higher Speed than the Frequency Reference	7-17
	◆ If Motor Deceleration is Slow	7-18
	◆ If the Motor Overheats	7-18
	◆ If peripheral devices like PLCs or other are influenced by the starting or running inverter 7-.....	19
	◆ If the Earth Leakage Breaker Operates when a RUN Command is Input	7-19
	◆ If There is Mechanical Oscillation	7-19
	◆ If the Motor Rotates Even When Inverter Output is Stopped	7-20
	◆ If OV (Overvoltage) or OC (Overcurrent) is Detected When a Fan is Started, or a Fan Stalls	7-20
	◆ If Output Frequency Does Not Rise to Frequency Reference	7-20
8	Maintenance and Inspection.....	8-1
	Maintenance and Inspection	8-2
	◆ Periodic Inspection	8-2
	◆ Periodic Maintenance of Parts	8-4
	◆ Cooling Fan Replacement Outline	8-5
	◆ Removing and Mounting the Control Circuit Terminal Card	8-7
9	Specifications	9-1
	Standard Inverter Specifications	9-2
	◆ Specifications by Model	9-2
	◆ Common Specifications	9-5
10	Appendix	10-1
	Inverter Application Precautions	10-2
	◆ Selection	10-2
	◆ Installation	10-2
	◆ Settings	10-3
	◆ Handling	10-3
	Motor Application Precautions	10-4
	◆ Using the Inverter for an Existing Standard Motor	10-4
	◆ Using the Inverter for Special Motors	10-5
	◆ Power Transmission Mechanism (Speed Reducers, Belts and Chains)	10-5
	User Parameters	10-6



Warnings



CAUTION

Cables must not be connected or disconnected, nor signal tests carried out, while the power is switched on.

The Varispeed E7 DC bus capacitor remains charged even after the power has been switched off. To avoid an electric shock hazard, disconnect the frequency inverter from the mains before carrying out maintenance. Then wait for at least 5 minutes after all LEDs have gone out.

Do not perform a withstand voltage test on any part of the Varispeed. The frequency inverter contains semiconductors, which are not designed for such high voltages.

Do not remove the digital operator while the mains supply is switched on. The printed circuit board must also not be touched while the inverter is connected to the power.

Never connect general LC/RC interference suppression filters, capacitors or overvoltage protection devices to the inverter input or output.

To avoid unnecessary overcurrent faults, etc. being displayed, the signaling contacts of any contactor or switch fitted between inverter and motor must be integrated into the inverter control logic (e.g. baseblock).

This is absolutely imperative!

This manual must be read thoroughly before connecting and operating the inverter. All safety precautions and instructions for use must be followed.

The inverter may must be operated with the appropriate line filters, following the installation instructions in this manual and with all covers closed and terminals covered.

Only then will adequate protection be provided. Please do not connect or operate any equipment with visible damage or missing parts. The operating company is responsible for any injuries or equipment damage resulting from failure to heed the warnings in this manual.

Safety Precautions and Instructions for Use

■ General

Please read these safety precautions and instructions for use thoroughly before installing and operating this inverter. Also read all of the warning signs on the inverter and ensure they are never damaged or removed.

Live and hot inverter components may be accessible during operation. Removal of housing components, the digital operator or terminal covers runs the risk of serious injuries or damage in the event of incorrect installation or operation. The fact that frequency inverters control rotating mechanical machine components can give rise to other dangers.

The instructions in this manual must be followed. Installation, operation and maintenance may only be carried out by qualified personnel. For the purposes of the safety precautions, qualified personnel are defined as individuals who are familiar with the installation, starting, operation and maintenance of frequency inverters and have the proper qualifications for this work. Safe operation of these units is only possible if they are used properly for their intended purpose.

The DC bus capacitors can remain live for about 5 minutes after the inverter is disconnected from the power. It is therefore necessary to wait for this time before opening its covers. All of the main circuit terminals may still carry dangerous voltages.

Children and other unauthorized persons must not be allowed access to these inverters.

Keep these Safety Precautions and Instructions for Use readily accessible and supply them to all persons with any form of access to the inverters.

■ Intended Use

Frequency inverters are intended for installation in electrical systems or machinery.

Their installation in machinery and systems must conform to the following product standards of the Low Voltage Directive:

EN 50178, 1997-10, Equipping of Power Systems with Electronic Devices

EN 60204-1, 1997-12 Machine Safety and Equipping with Electrical Devices

Part 1: General Requirements (IEC 60204-1:1997)/

Please note: Includes Corrigendum of September 1998

EN 61010-1, A2, 1995 Safety Requirements for Information Technology Equipment

(IEC 950, 1991 + A1, 1992 + A2, 1993 + A3, 1995 + A4, 1996, modified)

CE marking is carried out to EN 50178, using the line filters specified in this manual and following the appropriate installation instructions.

■ Transportation and storage

The instructions for transportation, storage and proper handling must be followed in accordance with the technical data.

■ Installation

Install and cool the inverters as specified in the documentation. The cooling air must flow in the specified direction. The inverter may therefore only be operated in the specified position (e.g. upright). Maintain the specified clearances. Protect the inverters against impermissible loads. Components must not be bent nor insulation clearances changed. To avoid damage being caused by static electricity, do not touch any electronic components or contacts.

■ Electrical Connection

Carry out any work on live equipment in compliance with the national safety and accident prevention regulations. Carry out electrical installation in compliance with the relevant regulations. In particular, follow the installation instructions ensuring electromagnetic compatibility (EMC), e.g. shielding, grounding, filter arrangement and laying of cables. This also applies to equipment with the CE mark. It is the responsibility of the manufacturer of the system or machine to ensure conformity with EMC limits.

Your supplier or Omron Yaskawa Motion Control representative must be contacted when using leakage current circuit breaker in conjunction with frequency inverters.

In certain systems it may be necessary to use additional monitoring and safety devices in compliance with the relevant safety and accident prevention regulations. The frequency inverter hardware must not be modified.

■ Notes

The Varispeed E7 frequency inverters are certified to CE, UL, and cUL except the IP54 version which is certified to CE only.

EMC Compatibility

■ Introduction

This manual was compiled to help system manufacturers using OMRON YASKAWA Motion Control (OYMC) frequency inverters design and install electrical switch gear. It also describes the measures necessary to comply with the EMC Directive. The manual's installation and wiring instructions must therefore be followed.

Our products are tested by authorized bodies using the standards listed below.

Product standard: EN 61800-3:1996

EN 61800-3; A11:2000

■ Measures to Ensure Conformity of OYMC Frequency inverters to the EMC Directive

OYMC frequency inverters do not necessarily have to be installed in a switch cabinet.

It is not possible to give detailed instructions for all of the possible types of installation. This manual therefore has to be limited to general guidelines.

All electrical equipment produces radio and line-borne interference at various frequencies. The cables pass this on to the environment like an aerial.

Connecting an item of electrical equipment (e.g. drive) to a supply without a line filter can therefore allow HF or LF interference to get into the mains.

The basic countermeasures are isolation of the wiring of control and power components, proper grounding and shielding of cables.

A large contact area is necessary for low-impedance grounding of HF interference. The use of grounding straps instead of cables is therefore definitely advisable.

Moreover, cable shields must be connected with purpose-made ground clips.

■ Laying Cables

Measures Against Line-Borne Interference:

Line filter and frequency inverter must be mounted on the same metal plate. Mount the two components as close to each other as possible, with cables kept as short as possible.

Use a power cable with well-grounded shield. For motor cables up to 50 meters in length use shielded cables. Arrange all grounds so as to maximize the area of the end of the lead in contact with the ground terminal (e.g. metal plate).

Shielded Cable:

– Use a cable with braided shield.

– Ground the maximum possible area of the shield. It is advisable to ground the shield by connecting the cable to the ground plate with metal clips (see following figure).

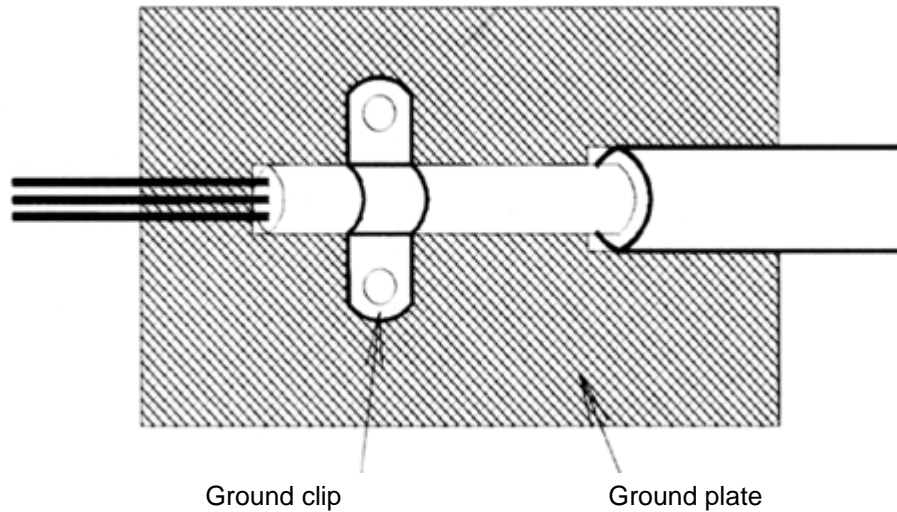

The grounding surfaces must be highly conductive bare metal. Remove any coats of varnish and paint.

- Ground the cable shields at both ends.
- Ground the motor of the machine.

Further informations can be found in the document EZZ006543 which can be ordered at Omron Yaskawa Motion Control.

Line Filters

The IP54 version is already equipped with a internal EMC filter. For the IP00 and NEMA 1 / IP20 versions of the Varispeed E7 the recommended line filters are as follows:

■ Recommended Line Filters for Varispeed E7 (IP00 and NEMA 1 / IP20)

Inverter Model	Line Filter				
	Model	EN 55011 Class	Current (A)	Weight (kg)	Dimensions W x D x H
CIMR-E7Z40P4	3G3RV-PFI3010-SE	B, 25 m ^{*1}	10	1.1	141 x 46 x 330
CIMR-E7Z40P7					
CIMR-E7Z41P5					
CIMR-E7Z42P2					
CIMR-E7Z43P7	3G3RV-PFI3018-SE		18	1.3	141 x 46 x 330
CIMR-E7Z44P0					
CIMR-E7Z45P5					
CIMR-E7Z47P5	3G3RV-PFI3035-SE		35	2.1	206 x 50 x 355
CIMR-E7Z4011					
CIMR-E7Z4015	3G3RV-PFI3060-SE		60	4.0	236 x 65 x 408
CIMR-E7Z4018					
CIMR-E7Z4022	3G3RV-PFI3070-SE		70	3.4	80 x 185 x 329
CIMR-E7Z4030					
CIMR-E7Z4037	3G3RV-PFI3130-SE	A, 100 m	130	4.7	90 x 180 x 366
CIMR-E7Z4045					
CIMR-E7Z4055					
CIMR-E7Z4075	3G3RV-PFI3170-SE		170	6.0	120 x 170 x 451
CIMR-E7Z4090	3G3RV-PFI3200-SE		250	11	130 x 240 x 610
CIMR-E7Z4110					
CIMR-E7Z4132	3G3RV-PFI3400-SE		400	18.5	300 x 160 x 610
CIMR-E7Z4160					
CIMR-E7Z4185	3G3RV-PFI3600-SE		600	11,0	260 x 135 x 386
CIMR-E7Z4220					
CIMR-E7Z4300	3G3RV-PFI3800-SE		800	31.0	300 x 160 x 716

*1. Class A, 100 m

Permissible emission of power drive systems for commercial and light environment (EN61800-3, A11) (general availability, 1st environment)

Inverter Model	Line Filters				
Varispeed E7 (IP00/20)	Type	EN 55011 Class	Current (A)	Weight (kg)	Dimensions W x D x H
CIMR-E7Z20P4	3G3RV-PFI3010-SE	B, 25 m ^{*1}	10	1.1	141 x 45 x 330
CIMR-E7Z20P7					
CIMR-E7Z21P5					
CIMR-E7Z22P2	3G3RV-PFI3018-SE		18	1.3	141 x 46 x 330
CIMR-E7Z23P7	3G3RV-PFI2035-SE		35	1.4	141 x 46 x 330
CIMR-E7Z25P5					
CIMR-E7Z27P5	3G3RV-PFI2060-SE		60	3	206 x 60 x 355
CIMR-E7Z2011					
CIMR-E7Z2015	3G3RV-PFI2100-SE		100	4.9	236 x 80 x 408
CIMR-E7Z2018					
CIMR-E7Z2022	3G3RV-PFI2130-SE	A, 100 m	130	4.3	90 x 180 x 366
CIMR-E7Z2030					
CIMR-E7Z2037	3G3RV-PFI2160-SE		160	6.0	120 x 170 x 451
CIMR-E7Z2045	3G3RV-PFI2200-SE		200	11.0	130 x 240 x 610
CIMR-E7Z2055					
CIMR-E7Z2075	3G3RV-PFI3400-SE		400	18.5	300 x 160 x 564
CIMR-E7Z2090					
CIMR-E7Z2110	3G3RV-PFI3600-SE	600	11.0	260 x 135 x 386	

*1. Class A, 100 ambient temperature: 45°C max

■ EMC Specifications of Varispeed E7 (IP54)

The Varispeed E7 IP54 is already equipped with an internal EMC filter. The Varispeed E7 IP54 complies with EN55011 class A with a motor cable length up to 25m.

For the wiring methods to comply with the EMC regulations for the Varispeed E7 (IP54) refer to page [Chapter 2, Wiring](#).

■ Installation inverters and EMC filters

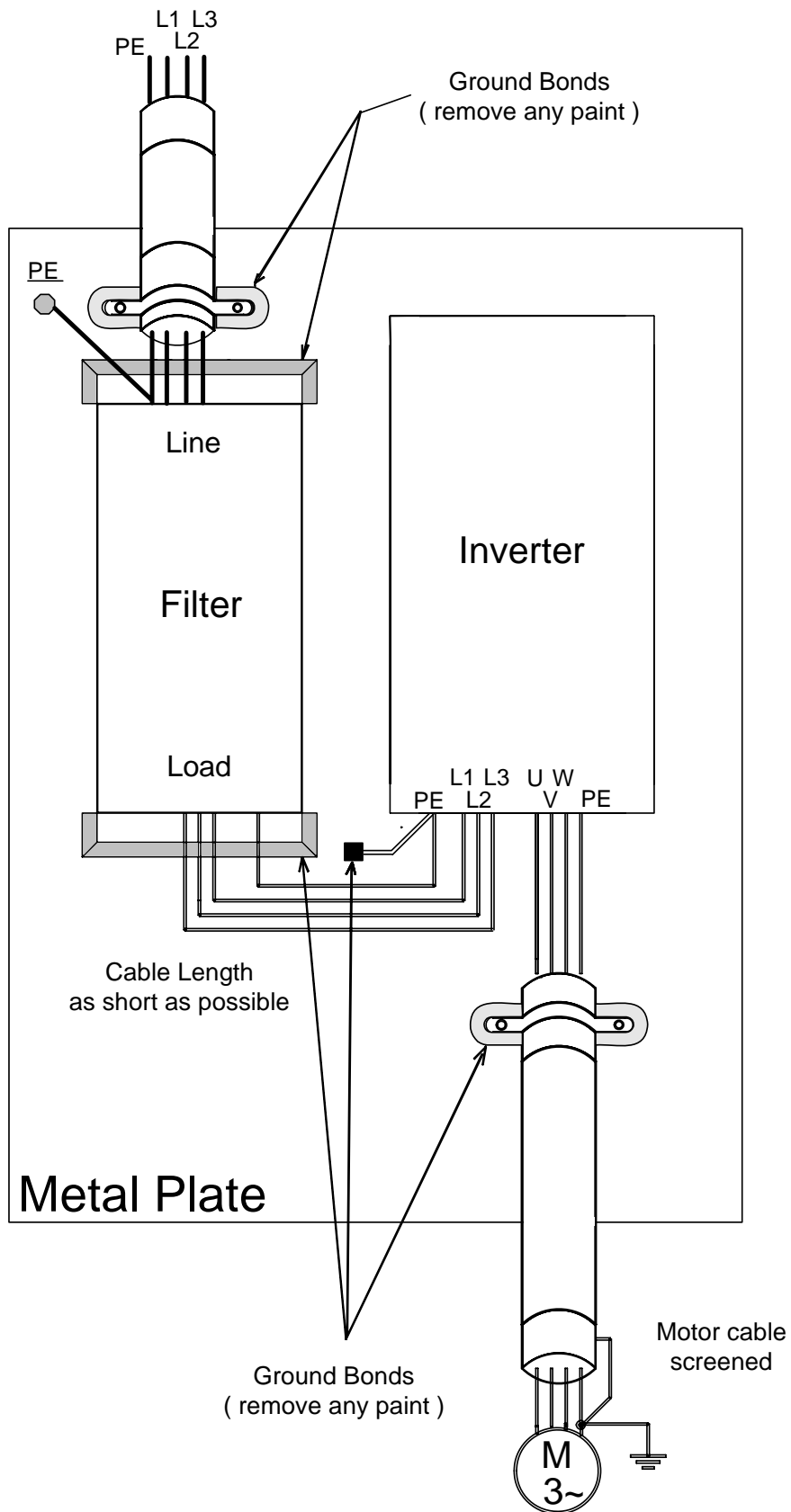

Registered Trademarks

The following registered trademarks are used in this manual.

- DeviceNet is a registered trademark of the ODVA (Open DeviceNet Vendors Association, Inc.).
- InterBus is a registered trademark of Phoenix Contact Co.
- ControlNet is a registered trademark of ControlNet International, Ltd.
- LONworks is a registered trademark of the Echelon.
- Metasys is a registered trademark of Johnson Controls Inc.
- CANopen is a registered trademark of CAN in Automation e.V.





1

Handling Inverters

This chapter describes the checks required upon receiving or installing an Inverter.

Varispeed E7 Introduction.....	1-2
Confirmations upon Delivery	1-4
Exterior and Mounting Dimensions	1-9
Checking and Controlling the Installation Site	1-13
Installation Orientation and Space	1-15
Accessing the Inverter Terminals.....	1-16
Removing/Attaching the Digital Operator and Front Cover	1-18

Varispeed E7 Introduction

◆ Varispeed E7 Applications

The Varispeed E7 is ideal for the following applications.

- Fan, blower and pump applications with variable torque characteristics.

Settings must be adjusted to the application for optimum operation. Refer to [page 4-1, Trial Operation](#).

◆ Varispeed E7 Models

The Varispeed E7 Series includes Inverters in two voltage classes: 200 V and 400 V. The maximum motor capacities vary from 0.55 to 300 kW. The inverter is available in protection classes IP00, IP20 and IP54 according to the following table:

Table 1.1 Varispeed E7 Models

Voltage Class	Maximum Motor Capacity kW	Varispeed E7		Specifications (Always specify through the protective structure when ordering.)			
		Output Capacity kVA	Basic Model Number	IEC IP00 CIMR-E7Z□□□□□□□□	NEMA 1 (IEC IP20) CIMR-E7Z□□□□□□□□	IEC IP54 CIMR-E7Z□□□□□□□□	
200 V class	0.55	1.2	CIMR-E7Z20P4	Remove the top and bottom covers from the IP20 model.	20P4□□	-	
	0.75	1.6	CIMR-E7Z20P7		20P7□□	-	
	1.5	2.7	CIMR-E7Z21P5		21P5□□	-	
	2.2	3.7	CIMR-E7Z22P2		22P2□□	-	
	3.7	5.7	CIMR-E7Z23P7		23P7□□	-	
	5.5	8.8	CIMR-E7Z25P5		25P5□□	-	
	7.5	12	CIMR-E7Z27P5		27P5□□	-	
	11	17	CIMR-E7Z2011		2011□□	-	
	15	22	CIMR-E7Z2015		2015□□	-	
	18.5	27	CIMR-E7Z2018		2018□□	-	
	22	32	CIMR-E7Z2022		2022□□	2022□□	-
	30	44	CIMR-E7Z2030		2030□□	2030□□	-
	37	55	CIMR-E7Z2037		2037□□	2037□□	-
	45	69	CIMR-E7Z2045		2045□□	2045□□	-
	55	82	CIMR-E7Z2055		2055□□	2055□□	-
	75	110	CIMR-E7Z2075		2075□□	2075□□	-
	90	130	CIMR-E7Z2090		2090□□	-	-
110	160	CIMR-E7Z2110	2110□□	-	-		

Voltage Class	Maximum Motor Capacity kW	Varispeed E7		Specifications (Always specify through the protective structure when ordering.)		
		Output Capacity kVA	Basic Model Number	IEC IP00 CIMR-E7Z□□□□□□□□	NEMA 1 (IEC IP20) CIMR-E7Z□□□□□□□□	IEC IP54 CIMR-E7Z□□□□□□□□
400 V class	0.55	1.4	CIMR-E7Z40P4	Remove the top and bottom covers from the IP20 model.	40P41□	-
	0.75	1.6	CIMR-E7Z40P7		40P71□	-
	1.5	2.8	CIMR-E7Z41P5		41P51□	-
	2.2	4.0	CIMR-E7Z42P2		42P21□	-
	3.7	5.8	CIMR-E7Z43P7		43P71□	-
	4.0	6.6	CIMR-E7Z44P0		44P01□	-
	5.5	9.5	CIMR-E7Z45P5		45P51□	-
	7.5	13	CIMR-E7Z47P5		47P51□	47P52□
	11	18	CIMR-E7Z4011		40111□	40112□
	15	24	CIMR-E7Z4015		40151□	40152□
	18.5	30	CIMR-E7Z4018	40181□	40182□	
	22	34	CIMR-E7Z4022	40220□	40221□	40222□
	30	46	CIMR-E7Z4030	40300□	40301□	40302□
	37	57	CIMR-E7Z4037	40370□	40371□	40372□
	45	69	CIMR-E7Z4045	40450□	40451□	40452□
	55	85	CIMR-E7Z4055	40550□	40551□	40552□
	75	110	CIMR-E7Z4075	40750□	40751□	-
	90	140	CIMR-E7Z4090	40900□	40901□	-
	110	160	CIMR-E7Z4110	41100□	41101□	-
	132	200	CIMR-E7Z4132	41320□	41321□	-
160	230	CIMR-E7Z4160	41600□	41601□	-	
185	280	CIMR-E7Z4185	41850□	-	-	
220	390	CIMR-E7Z4220	42200□	-	-	
300	510	CIMR-E7Z4300	43000□	-	-	

Confirmations upon Delivery

◆ Checks

Check the following items as soon as the Inverter is delivered.

Table 1.2 Checks upon delivery

Item	Method
Has the correct Inverter model been delivered?	Check the model number on the nameplate on the side of the Inverter.
Is the Inverter damaged in any way?	Inspect the entire exterior of the Inverter to see if there are any scratches or other damage resulting from shipping.
Are any screws or other components loose?	Use a screwdriver or other tools to check for tightness.

Additionally check that following parts are delivered in the package with the IP54 inverter:

Table 1.3 Additional Deliveries with IP54 Inverters

Part Name	Qty.
Cable Gland (for Input)	1
Cable Gland (for Motor Output)	1
Cable Gland (for Control)	1
Cable Gland (for Fieldbus)	1
Door Key	1
Blind Plug (Control Cable Entry)	1
Blind Plug (Fieldbus Cable Entry)	1

If any irregularities in the above items are found, contact the agency from which the Inverter was purchased or your Omron Yaskawa Motion Control representative immediately.

◆ Nameplate Information

There is a nameplate attached to the side of each Inverter. The nameplate shows the model number, specifications, lot number, serial number, and other information on the Inverter.

■ Example Nameplate

The following nameplate is an example for a standard European Inverter: 3-phase, 400 VAC, 0.55 kW, NEMA 1 / IP20 standards

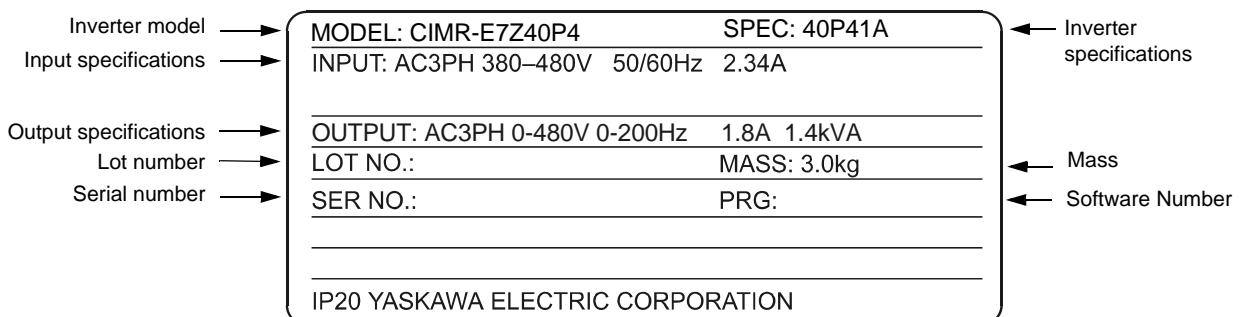

Fig 1.1 Nameplate Example

■ Inverter Model Numbers

The model number of the Inverter on the nameplate indicates the specification, voltage class, and maximum motor capacity of the Inverter in alphanumeric codes.

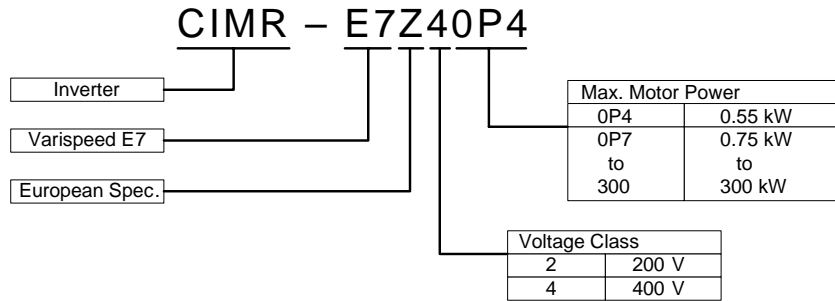

Fig 1.2 Inverter Model Numbers

■ Inverter Specifications

The Inverter specifications (“SPEC”) on the nameplate indicate the voltage class, maximum motor capacity, the protective structure, and the revision of the Inverter in alphanumeric codes.

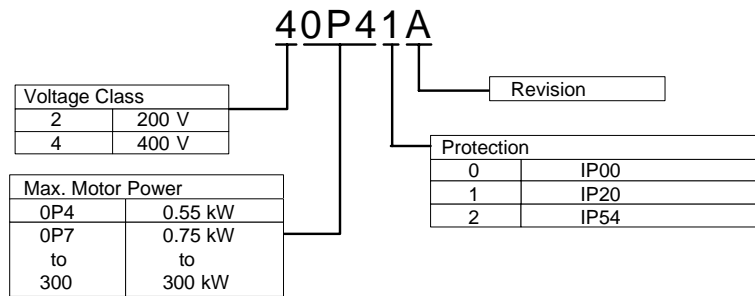

Fig 1.3 Inverter Specifications

◆ Inverter Software Version

The Inverter software version can be read out from the monitor parameter U1-14. The parameter shows the last four digits of the software number (e.g. display is “3021” for the software version VSE103021).



This manual describes the functionality of the inverter software version VSE103021. Older software versions do not support all described functions. Check the software versions before starting to work with this manual.

◆ Component Names

■ Inverters of 18.5 kW or Less

The external appearance and component names of the Inverter are shown in *Fig 1.4*, the terminal arrangement in *Fig 1.5*

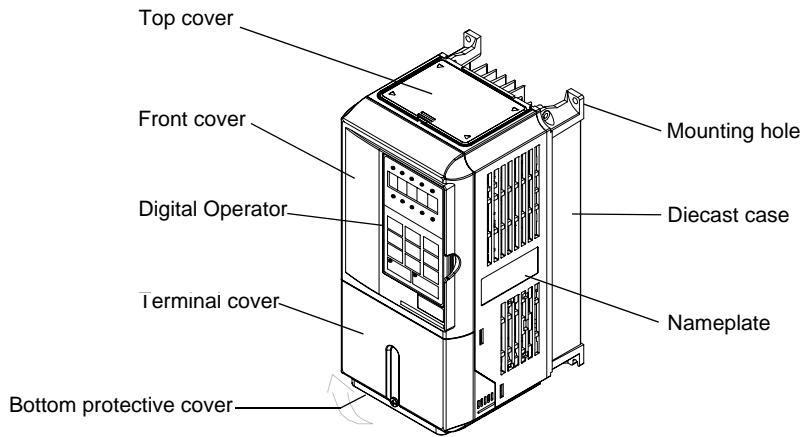

Fig 1.4 NEMA 1 Inverter Appearance (18.5 kW or Less)



The top cover is a protection against foreign bodies (screws, metal scrap from drilling etc.), which could fall into the inverter during the installation in the cabinet. Remove the top cover when the installation is finished!

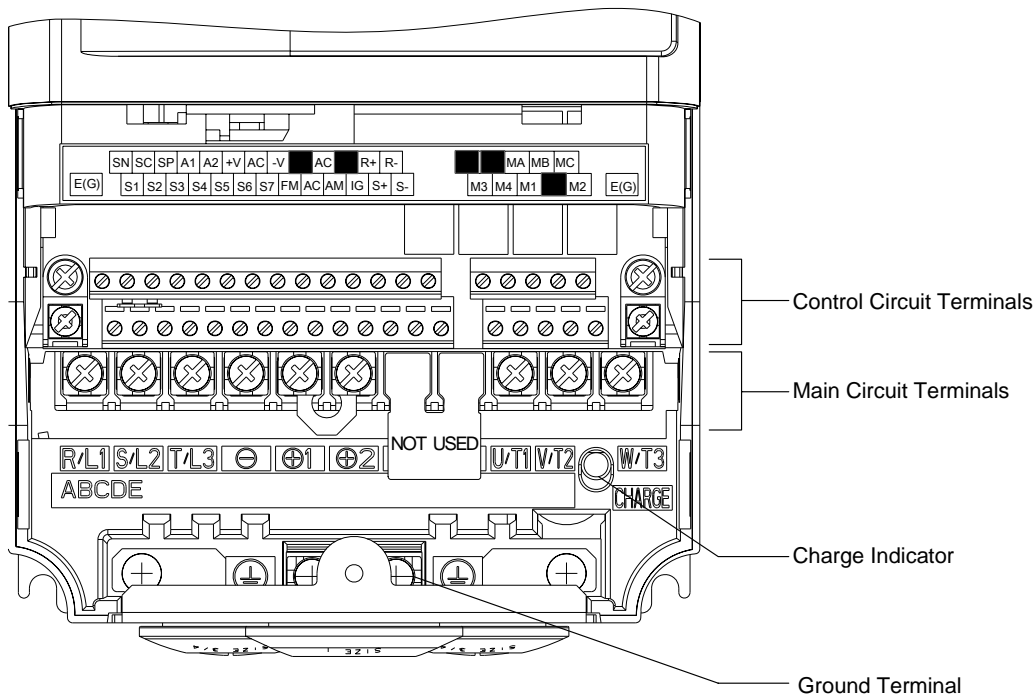

Fig 1.5 Terminal Arrangement (18.5 kW or less)

■ Inverters of 22 kW or More

The external appearance and component names of the Inverter are shown in Fig 1.6, the terminal arrangement in Fig 1.7

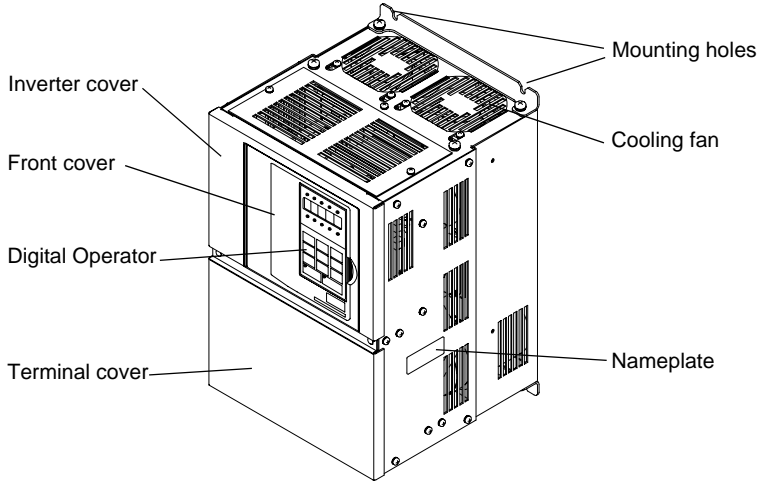

Fig 1.6 Inverter Appearance (22 kW or More)

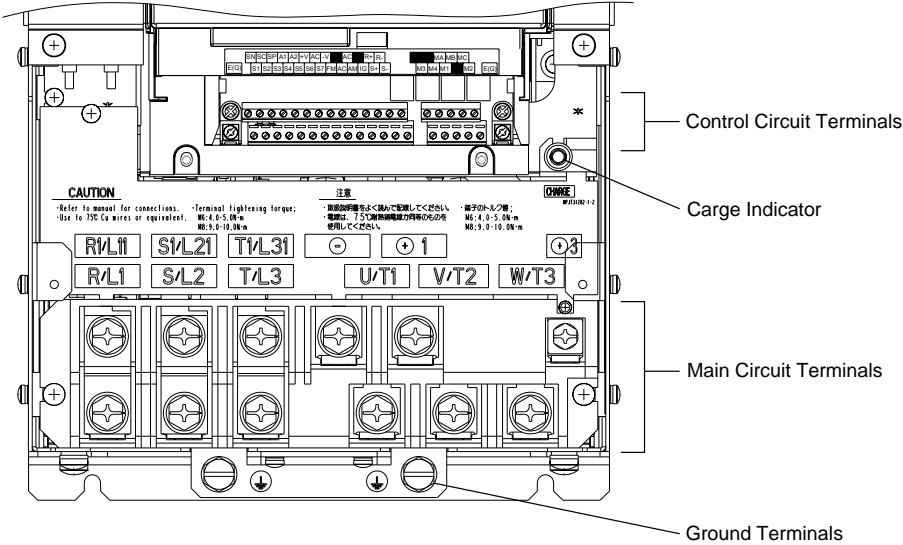

Fig 1.7 Terminal Arrangement (22kW or More)

■ Protection Class IP54

The external appearance and component names of the Inverter are shown in *Fig 1.8*.

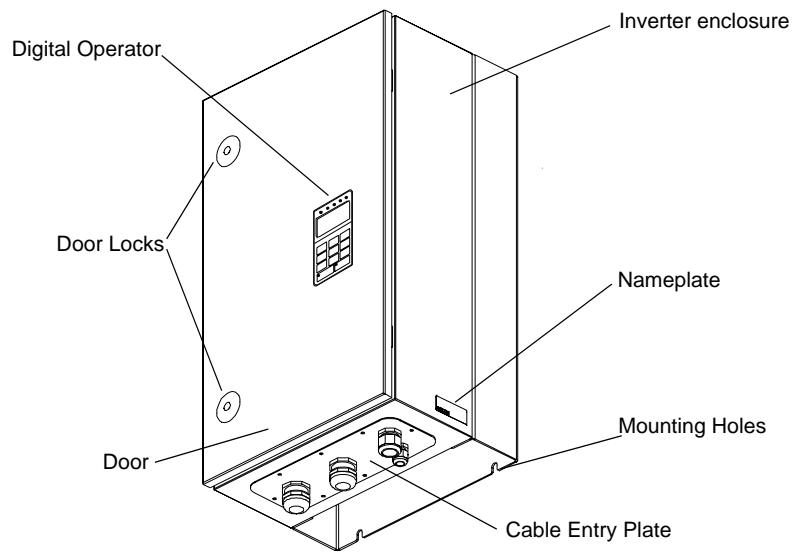
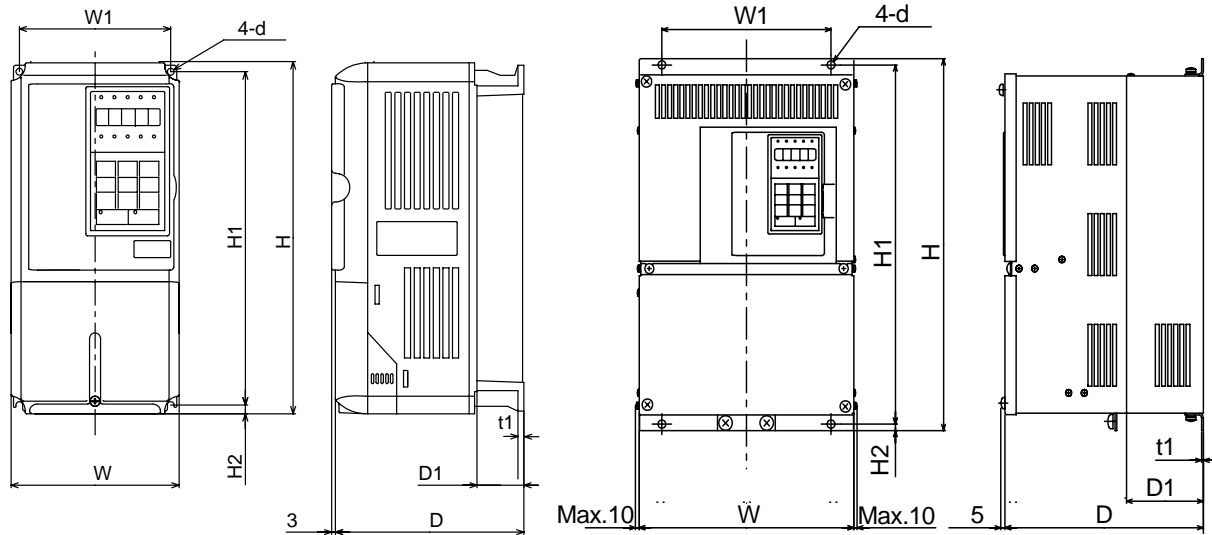

Fig 1.8 IP54 Inverter Appearance

Exterior and Mounting Dimensions

◆ IP00 Inverters



200 V/400 V Class Inverters of 0.55 to 18.5 kW

200 V Class Inverters of 22 or 110 kW
400 V Class Inverters of 22 to 160 kW

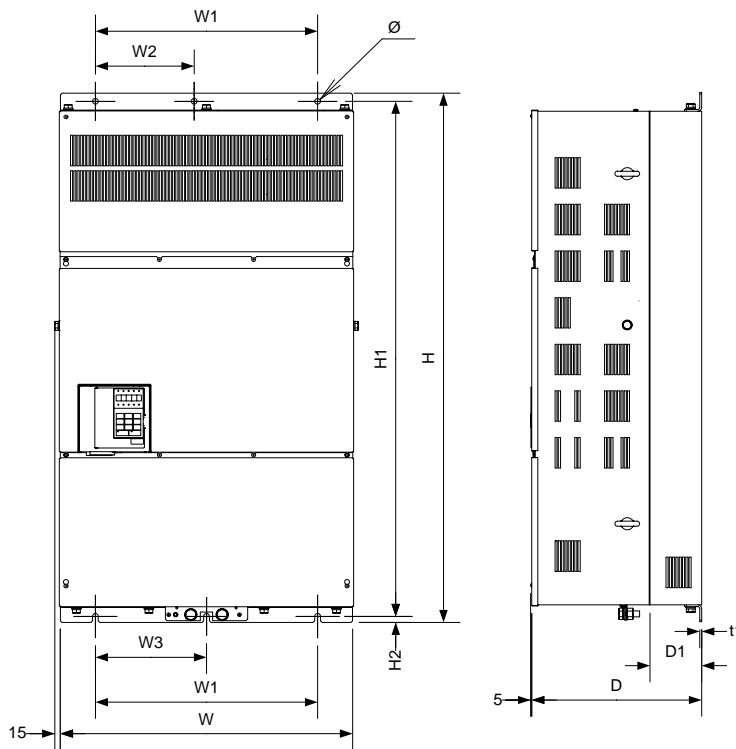

400 V Class Inverters of 185 to 300 kW

Fig 1.9 Exterior Diagrams of IP00 Inverters

◆ NEMA 1 / IP20 Inverters

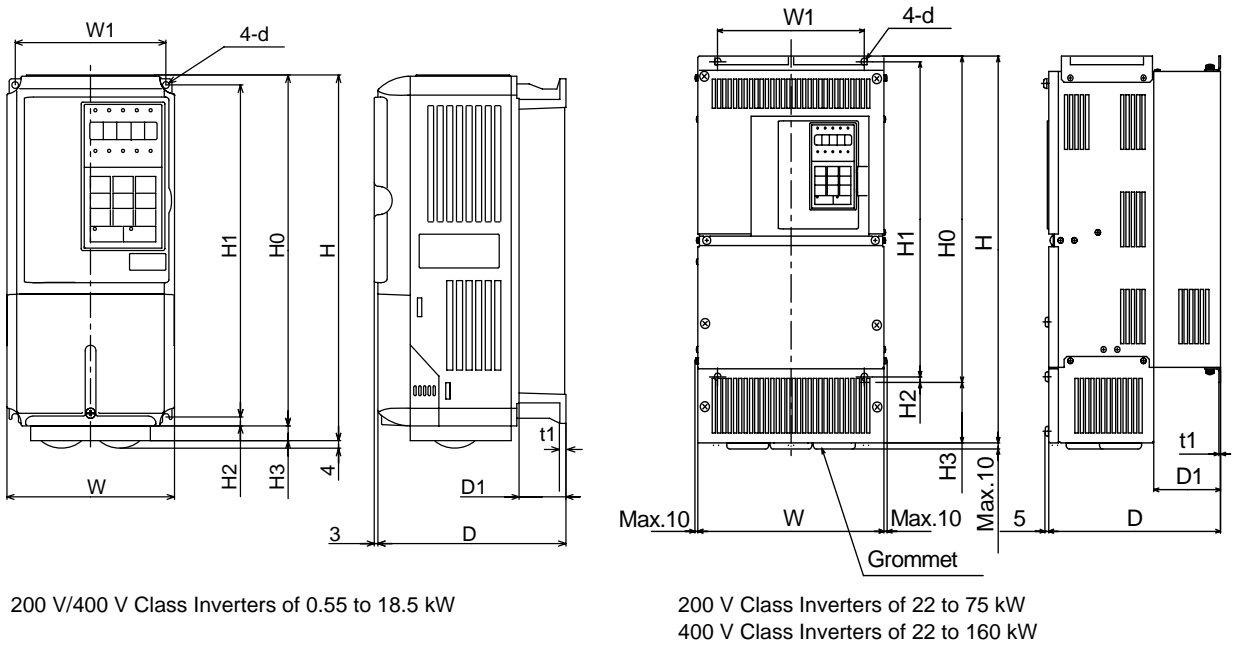

Fig 1.10 Exterior Diagrams of NEMA 1 / IP20 Inverters

◆ IP54 Inverters

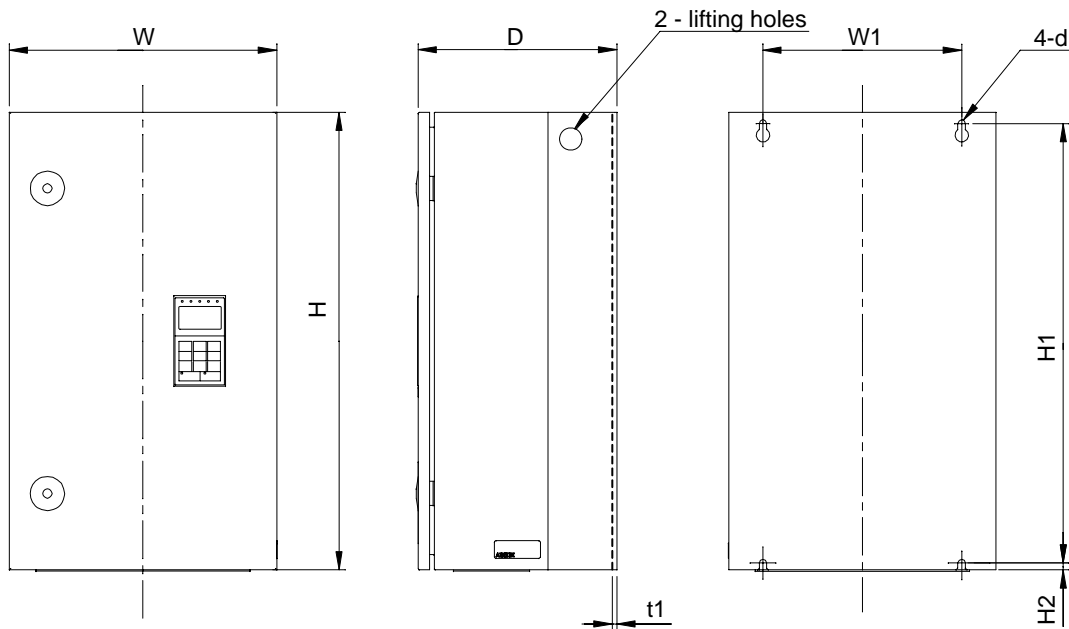

Fig 1.11 Exterior Diagrams of IP54 Inverters

Table 1.4 Inverter Dimensions (mm) and Masses (kg) from 0.4 to 160 kW, IP00 and NEMA 1 / IP20

Voltage Class	Max. Applicable Motor Output [kW]	Dimensions (mm)																				Caloric Value (W)			Cooling Method		
		Protection Class IP00										Protection Class NEMA 1 / IP20										External	Internal	Total Heat Generation			
		W	H	D	W1	H1	H2	D1	t1	Approx. Mass	W	H	D	W1	H0	H1	H2	H3	D1	t1	Approx. Mass					Mounting Holes d*	
200 V (3-phase)	0.55	140	280	157	126	266	7	39	5	3	140	280	157	126	280	266	7	0	39	5	3	M5	20	39	59	Natural	
	0.75																						27	42	69		
	1.5																						50	50	100		
	2.2			70	59	129																					
	3.7			112	74	186																					
	5.5	177	200	300	197	186	285	7.5	65.5	6	200	300	197	186	300	285	8	0	65.5	6	6	219	113	332	Fan		
	7.5	374																								170	544
	11	429	183	612																							
	15	501	211	712																							
	18.5	586	274	860																							
	22	250	400	258	195	385	8	78	2.3	11	240	350	207	216	350	335	7.5	0	78	2.3	11	62	1015	411		1426	
	30	275	450	220	435	7.5	100	2.3	21	254	535	258	195	400	385	7.5	30	135	100	24	27	68	1266	505		1771	
	37	375	600	298	250	575	12.5	100	3.2	57	380	809	298	250	600	575	12.5	209	100	62	94	M10	1015	411		1426	
	45			86						453													1027	348		325	725
	55	450	725	348	325	700	15	130	4.5	87	504	1243	358	370	850	820	15	390	4.5	114	M12	2019	838	2857			
75	108									504												1243	358	370		850	820
90	500	850	358	370	820	15	140	4.5	150	---										114	M12	2733	1242	3975			
110	575	885	378	445	855	15	140	4.5	150	---										114	M12	2733	1242	3975			
400 V (3-phase)	0.55	140	280	157	126	266	7	39	5	3	140	280	157	126	266	266	7	0	39	5	3	M5	14	39		53	Natural
	0.75																						17	41		58	
	1.5																						36	48	84		
	2.2			59	56	115																					
	3.7			80	68	148																					
	4.0	91	70	161																							
	5.5	127	82	209																							
	7.5	200	300	197	186	285	8	65.5	6	200	300	197	186	300	285	8	0	65.5	6	6	193	114	307	Fan			
	11																								252	158	410
	15	326	172	498																							
	18.5	426	208	634																							
	22	279	450	258	220	435	7.5	100	2.3	21	279	535	258	220	450	435	7.5	85	100	24	24	466	259		725		
	30	325	550	283	260	535	105	105	3.6	36	329	715	283	260	550	535	165	105	40	1203	495	1698					
	37									784													360		1144		
	45	901	415	1316																							
55	1203	495	1698																								
75	450	725	348	325	700	12.5	130	3.2	88	453	1027	348	325	725	700	12.5	302	130	96	97	M10	1399	575		1974		
90									89													1614	671		2285		
110	500	850	358	370	820	15	130	4.5	102	504	1243	358	370	850	820	15	393	4.5	130	M12	2097	853	2950				
132									120												2388	1002	3390				
160	575	916	378	445	855	45.8	140	4.5	160	579	1324	378	445	916	855	46	408	140	170	M12	2791	1147	3938				

Table 1.5 Inverter Dimensions (mm) and Masses (kg) of 400V Class Inverters of 185 kW to 300 kW, IP00

Voltage Class	Max. Applicable Motor Output [kW]	Dimensions (mm)											Mounting Holes d	Caloric Value (W)			Cooling Method			
		Protection Class IP00												External	Internal	Total Heat Generation				
		W	H	D	W1	W2	W3	H1	H2	D1	t1	Approx. Mass								
400V (3-phase)	185	710	1305	413	540	240	270	1270	15	125.5	4.5	260	M12	3237	1372	4609	Fan			
	220																	3740	1537	5277
	300																	5838	2320	8158

Table 1.6 Inverter Dimensions (mm) and Masses (kg) of 400V class inverters 7.5 to 55 kW, IP54

Voltage Class	Max. Applicable Motor Output [kW]	Dimensions (mm)							Approx. Mass	Mounting Holes d	Total Heat Generation	Cooling Method
		W	H	D	W1	H1	H2	t1				
400V (3-phase)	7.5	350	600	240	260	576	9	2.5	25	Ø 10 M8	302	Fan
	11			423								
	15			531								
	18.5	260	30	655								
	22	410	650	300	270	620	12	2.5	43	Ø 12 M10	754	
	30										989	
	37										1145	
	45	580	750	330	410	714	11	2.5	71	Ø 14 M10	1317	
55	1701											

Checking and Controlling the Installation Site

Install the Inverter in the installation site described below and maintain optimum conditions.

◆ Installation Site

Install the Inverter under the following conditions in a pollution degree 2 environment.

Type	Ambient Operating Temperature	Humidity
Protection Class IP20 and IP54	-10 to + 40 °C	95% RH or less (no condensation)
Protection Class IP00	-10 to + 45 °C	95% RH or less (no condensation)

Protection covers are attached to the top and bottom of the NEMA 1 and IP00 Inverters. Be sure to remove the top cover before operating a 200 or 400 V Class Inverter with an output of 18.5 kW or less inside a panel.

- Observe the following precautions when mounting the Inverter.
- Install the Inverter in a clean location which is free from oil mist and dust. It can be installed in a totally enclosed panel that is completely shielded from floating dust.
- When installing or operating the Inverter, always take special care so that metal powder, oil, water, or other foreign matter does enter the Inverter.
- Do not install the Inverter on combustible material, such as wood.
- Install the Inverter in a location free from radioactive materials and combustible materials.
- Install the Inverter in a location free from harmful gasses and liquids.
- Install the Inverter in a location without excessive oscillation.
- Install the Inverter in a location free from chlorides.
- Install the Inverter in a location without in direct sunlight.
- The IP54 Inverters provide protection from non-conductive dust and splashing water from all directions. Install the Inverter indoors in a heated and controlled environment to avoid condensation inside the Inverter.
- Keep any water or dust outside of the IP54 Inverter when wiring.

◆ Controlling the Ambient Temperature

To enhance the reliability of operation, the Inverter should be installed in an environment free from extreme temperature increases. If the IP00 or NEMA 1 Inverter is installed in an enclosed environment, such as a box, use a cooling fan or air conditioner to maintain the internal air temperature below 45°C.

When the IP54 Inverter is installed in a environment with low temperatures or when the Inverter remains switched off for a long time, condensation may occur inside the Inverter. In that case additional heaters may effectively prevent condensation inside the inverter.

◆ Protecting the IP00 or NEMA 1 Inverter from Foreign Matter

Place a cover over the Inverter during installation to shield it from metal power produced by drilling.

Always remove the cover from the Inverter after completing installation. Otherwise, ventilation will be reduced, causing the Inverter to overheat.

◆ Additional Installation Precautions for the IP54 Inverters

- Ensure that the door locks are closed before carrying the Inverter. Always hold the case when carrying the Inverter, do not carry it holding the door or the cable glands. If the door locks are open or the Inverter is held by the door (or cable glands) when carrying the main body of the Inverter may fall, possibly resulting in injury.
- Pay attention not to damage the cable glands when lifting. Otherwise the equipment may be damaged by ingress of water or dust.

◆ Keeping the IP54 protection

- Mount the blind plugs attached for option and control entry if these terminals are not connected
- Pay attention not to damage the cable glands during the installation

Installation Orientation and Space

Install the Inverter vertically so as not to reduce the cooling effect. When installing the Inverter, always provide the following installation space to allow normal heat dissipation.

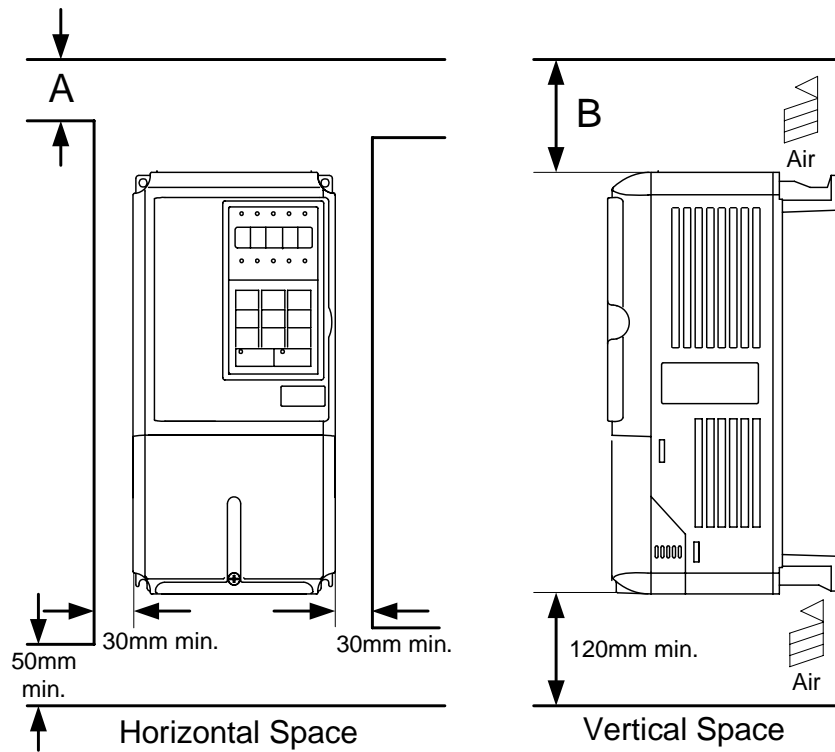

	A	B
200V class inverter, 0.55 to 90 kW	50 mm	120 mm
400V class inverter, 0.55 to 132 kW		
200V class inverter, 110 kW	120 mm	120 mm
400V class inverter, 160 to 220 kW		
400V class inverter, 300 kW	300 mm	300 mm

Fig 1.12 Inverter Installation Orientation and Space



1. The same space is required horizontally and vertically for Inverters of all protection classes, either IP00, NEMA 1 / IP20 and IP54 Inverters.
2. Always remove the top cover after installing a 200 or 400 V Class Inverter with an output of 18.5 kW or less in a panel.
3. Always provide enough space for suspension eye bolts and the main circuit lines when installing a 200 or 400 V Class Inverter with an output of 22 kW or more in a panel.
4. When IP54 Inverters are installed side by side provide a distance of 60mm or more between the Inverters

Accessing the Inverter Terminals

◆ Removing the Terminal Cover (IP00 and NEMA 1 / IP20 Inverters)

■ Inverters of 18.5 kW or Less

Loosen the screw at the bottom of the terminal cover, press in on the sides of the terminal cover in the directions of arrows 1, and then lift up on the terminal in the direction of arrow 2.

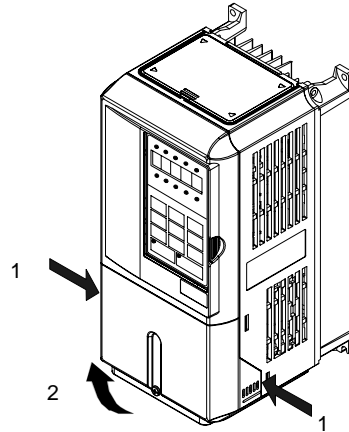

Fig 1.13 Removing the Terminal Cover (Model CIMR-E7Z25P51 Shown Above)

■ Inverters of 22 kW or More

Loosen the screws on the left and right at the top of the terminal cover, pull out the terminal cover in the direction of arrow 1 and then lift up on the terminal in the direction of arrow 2.

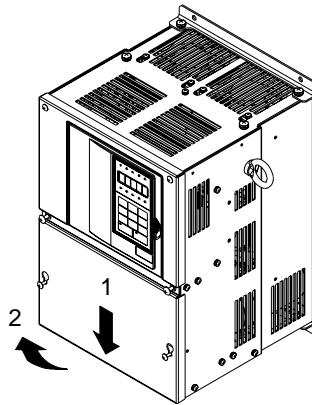

Fig 1.14 Removing the Terminal Cover (Model CIMR-E7Z20220 Shown Above)

◆ Attaching the Terminal Cover

When wiring the terminal block has been completed, attach the terminal cover by reversing the removal procedure.

For Inverters with an output of 18.5 kW or less, insert the tab on the top of the terminal cover into the groove on the Inverter and press in on the bottom of the terminal cover until it clicks into place.

◆ Opening the Door (IP54 Inverters)

Unlock the door locks with the provided key by pushing and rotating it 90 degrees in the directions of arrow 1 and open the door in the direction of arrow 2.

When opening the door, always take special care so that powder, oil, water or other foreign materials do not enter the Inverter.

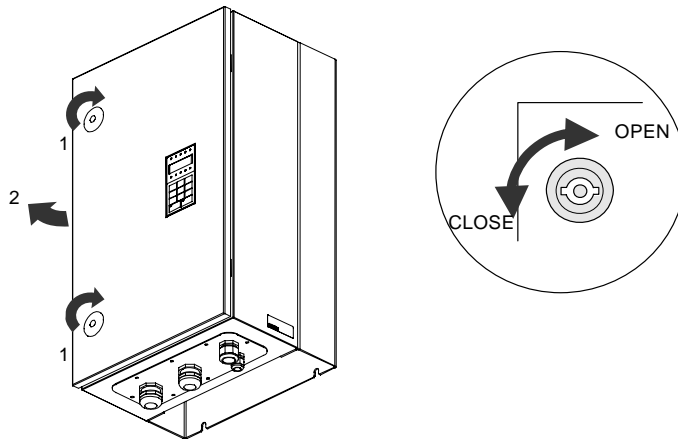

Fig 1.15 Opening the door on a IP54 inverter



Max. permitted door opening angle is approx. 135 degrees.

Opening the door over 135 degrees may damage the door hinges.

If the inverter is put into horizontal orientation for wiring or maintenance, the door should be supported and operation should be finished quickly to avoid stress to the door hinges.

◆ Closing the Door (IP54 Inverters)

Close and lock the door tightly by reversing the opening procedure.

Removing/Attaching the Digital Operator and Front Cover

The digital operator can only be removed on Inverters in protection class IP00 and NEMA 1 / IP20

◆ Inverters of 18.5 kW or Less

To attach optional cards or change the terminal board, remove the Digital Operator and front cover in addition to the terminal cover. Always remove the Digital Operator from the front cover before removing the front cover itself.

The removal and attachment procedures are described below.

■ Removing the Digital Operator

Press the lever on the side of the Digital Operator in the direction of arrow 1 to unlock the Digital Operator and lift the Digital Operator in the direction of arrow 2 to remove the Digital Operator as shown in the following illustration.

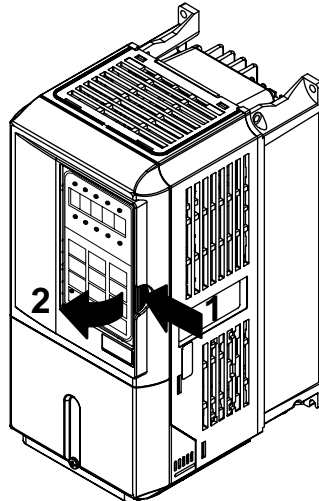

Fig 1.16 Removing the Digital Operator (Model CIMR-E7Z45P5 Shown Above)

■ Removing the Front Cover

Press the left and right sides of the front cover in the directions of arrows 1 and lift the bottom of the cover in the direction of arrow 2 to remove the front cover as shown in the following illustration.

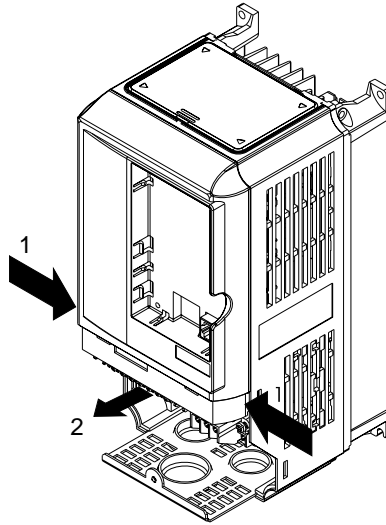

Fig 1.17 Removing the Front Cover (Model CIMR-E7Z45P5 Shown Above)

■ Mounting the Front Cover

After wiring the terminals, mount the front cover to the Inverter by performing the steps to remove the front cover in reverse order.

1. Do not mount the front cover with the Digital Operator attached to the front cover; otherwise, Digital Operator may malfunction due to imperfect contact.
1. Insert the tab of the upper part of the front cover into the groove of the Inverter and press the lower part of the front cover onto the Inverter until the front cover snaps shut.

■ Mounting the Digital Operator

After attaching the terminal cover, mount the Digital Operator onto the Inverter using the following procedure.

1. Hook the Digital Operator at A (two locations) on the front cover in the direction of arrow 1 as shown in the following illustration.
1. Press the Digital Operator in the direction of arrow 2 until it snaps in place at B (two locations).

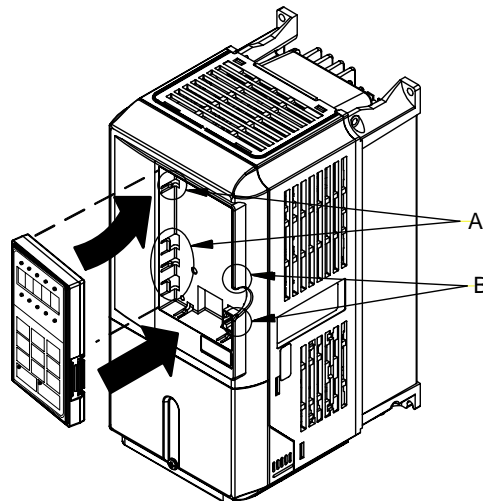

Fig 1.18 Mounting the Digital Operator



1. Do not remove or attach the Digital Operator or mount or remove the front cover using methods other than those described above, otherwise the Inverter may break or malfunction due to imperfect contact.
2. Never attach the front cover to the Inverter with the Digital Operator attached to the front cover. Imperfect contact can result.
Always attach the front cover to the Inverter by itself first, and then attach the Digital Operator to the front cover.

◆ Inverters of 22 kW or More

For inverters with an output of 22 kW or more, remove the terminal cover and then use the following procedures to remove the Digital Operator and front cover.

■ Removing the Digital Operator

Use the same procedure as for Inverters with an output of 18.5 kW or less.

■ Removing the Front Cover

Lift up at the location label 1 at the top of the control circuit terminal card in the direction of arrow 2.

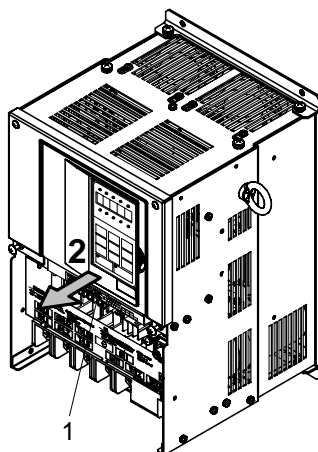

Fig 1.19 Removing the Front Cover (Model CIMR-E7Z2022 Shown Above)

■ Attaching the Front Cover

After completing required work, such as mounting an optional card or setting the terminal card, attach the front cover by reversing the procedure to remove it.

1. Confirm that the Digital Operator is not mounted on the front cover. Contact faults can occur if the cover is attached while the Digital Operator is mounted to it.
2. Insert the tab on the top of the front cover into the slot on the Inverter and press in on the cover until it clicks into place on the Inverter.

■ Attaching the Digital Operator

Use the same procedure as for Inverters with an output of 18.5 kW or less.



2

Wiring

This chapter describes wiring terminals, main circuit terminal connections, main circuit terminal wiring specifications, control circuit terminals, and control circuit wiring specifications.

Connection Diagrams	2-2
Terminal Block Configuration	2-5
Wiring Main Circuit Terminals	2-7
Wiring Control Circuit Terminals	2-27
Wiring Check.....	2-37
Installing and Wiring Option Cards	2-38

Connection Diagrams

The connection diagrams of the Inverters are shown in *Fig 2.1* and *Fig 2.2*

When using the Digital Operator, the motor can be operated by wiring only the main circuits.

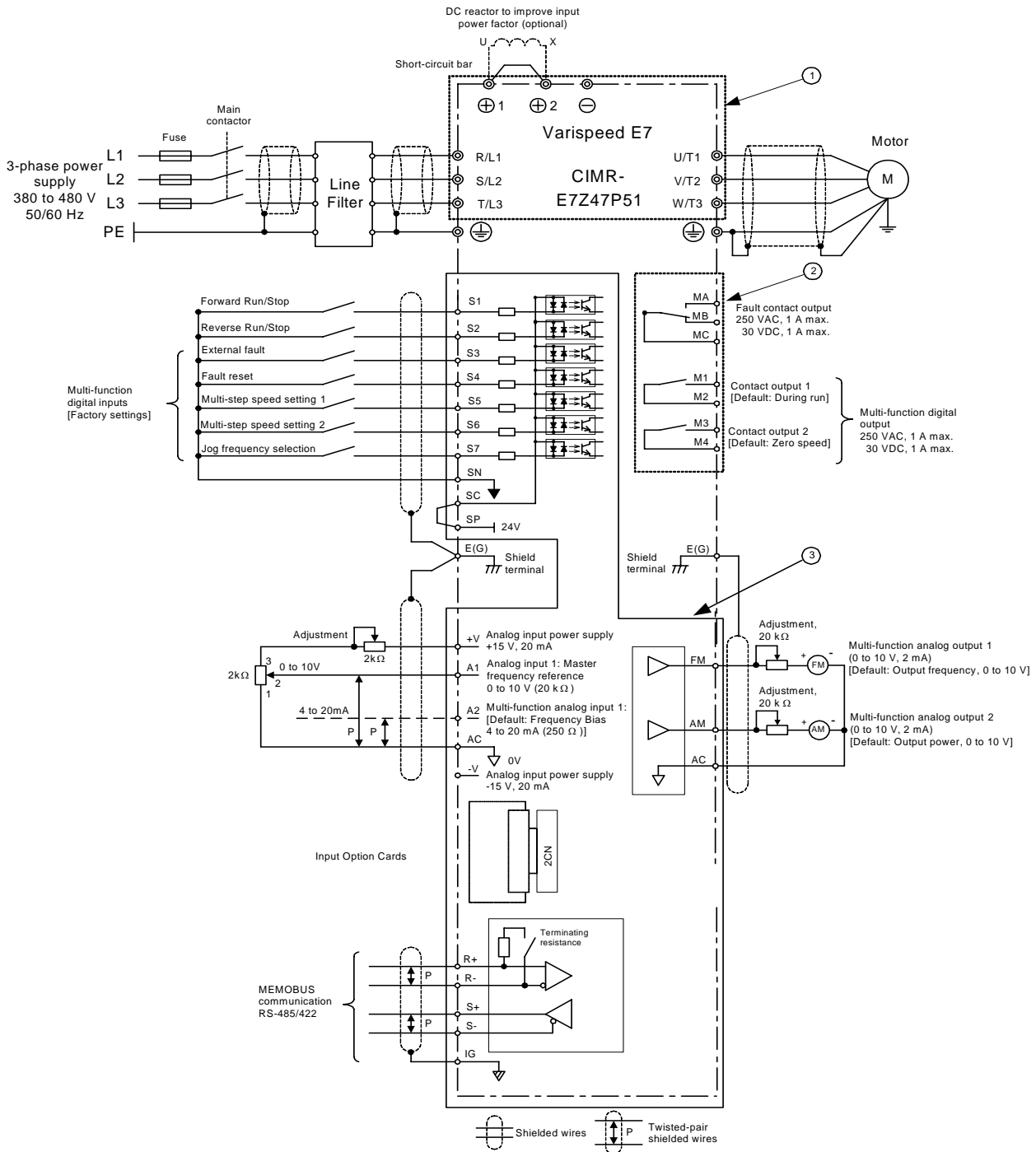

Fig 2.1 Connection Diagram of IP20 Inverters (Model CIMR-E7Z47P51 Shown Above)

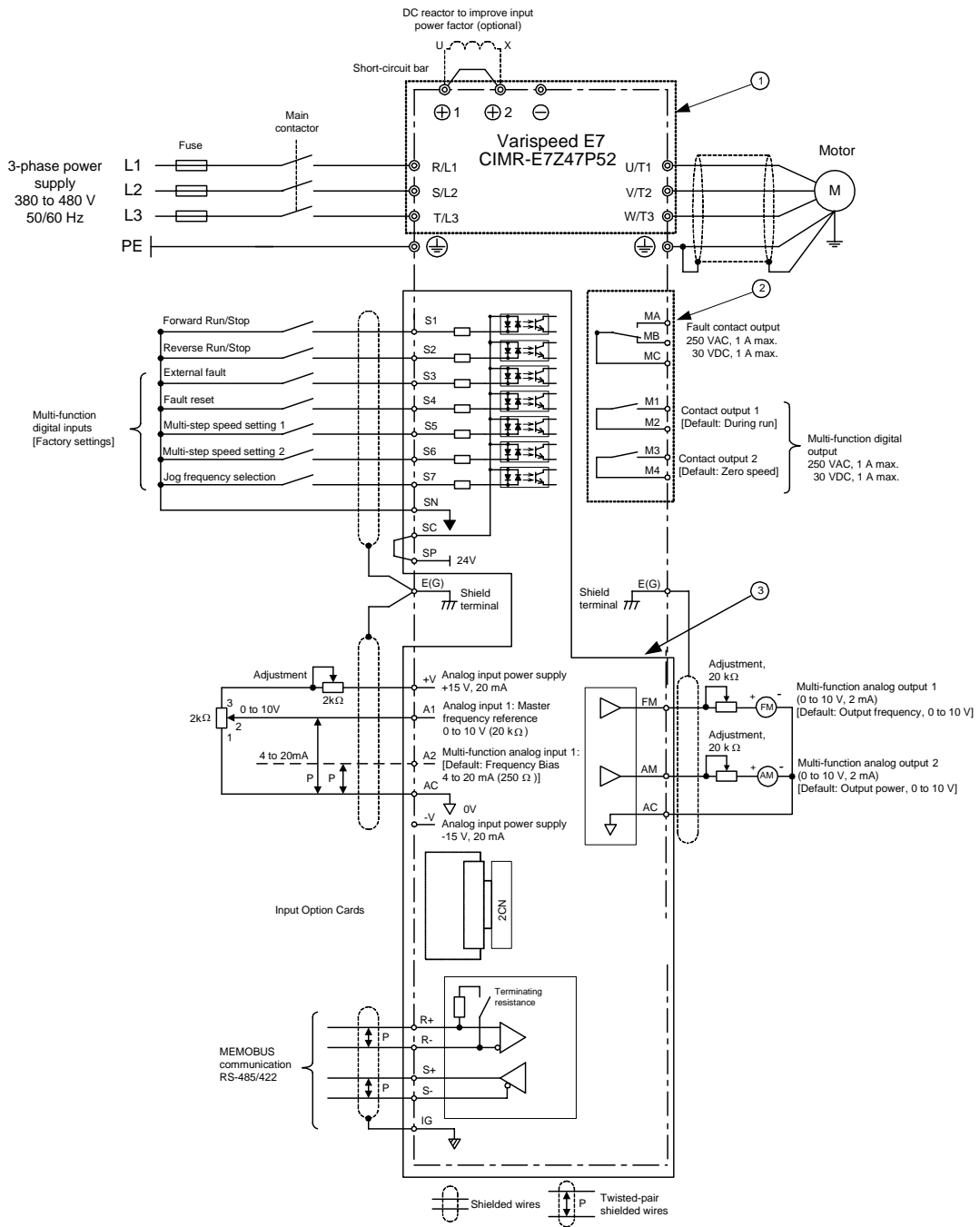

Fig 2.2 Connection Diagram of IP54 Inverters (Model CIMR-E7Z47P52 Shown Above)

◆ Circuit Descriptions

Refer to the numbers indicated in *Fig 2.1* and *Fig 2.2*.

- ① These circuits are hazardous and are separated from accessible surfaces by protective separation.
- ② These circuits are separated from all other circuits by protective separation consisting of double and reinforced insulation. These circuits may be interconnected with SELV (or equivalent) or non-SELV* circuits, but not both.
- ③ **Inverter supplied by four-wire-system source (neutral grounded)**
 These circuits are SELV* circuits and are separated from all other circuits by protective separation consisting of double and reinforced insulation. These circuits may only be interconnected with other SELV* (or equivalent) circuits.

Inverter supplied by three-wire-system source (ungrounded or corner grounded)

These circuits are not separated from hazardous circuits by protective separation, but only with basic insulation. These circuits must not be interconnected with any circuits which are accessible, unless they are isolated from accessible circuits by supplemental insulation.

* SELV (Safety Extra Low Voltage) circuits have no direct connection to the primary power and are supplied by a transformer or equivalent isolating device. The circuits are designed and protected, so that, under normal and fault condition, its voltage does not exceed a safe value. (See IEC 61010)



1. Control circuit terminals are arranged as shown below.

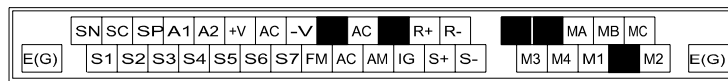

2. The output current capability of the +V terminal is 20 mA.
3. Main circuit terminals are indicated with double circles and control circuit terminals are indicated with single circles.
4. The wiring of the digital inputs S1 to S7 is shown for the connection of relay contacts or NPN transistors (0V common and sinking mode). This is the default setting.
 For the connection of PNP transistors or for using a 24V external power supply, refer to [page 2-33, Sinking/Sourcing Mode](#).
5. The master speed frequency reference can be input either at terminal A1 or at terminal A2 by changing the setting of parameter H3-13. The default setting is terminal A2.
6. DC reactors to improve the input power factor are built into 200 V Class Inverters from 22 up to 110 kW and 400 V Class Inverters from 22 up to 300 kW. A DC reactor is an option only for Inverters of 18.5 kW or less. Remove the short circuit bar when connecting a DC reactor.

Terminal Block Configuration

The terminal arrangements are shown in *Fig 2.3* and *Fig 2.4*.

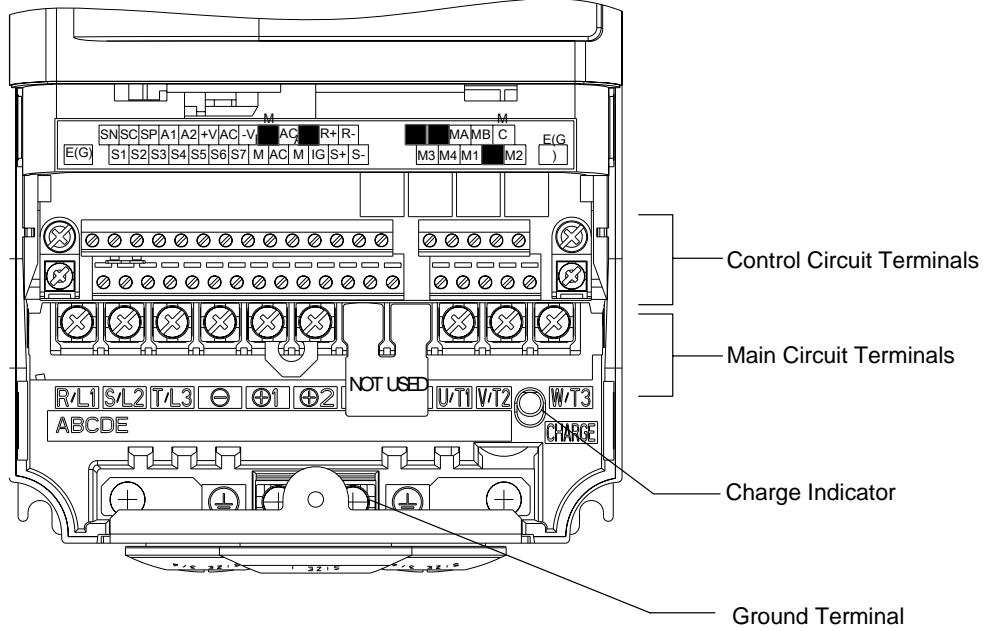

Fig 2.3 Terminal Arrangement (200V / 400V Class Inverter of 0.4 kW)

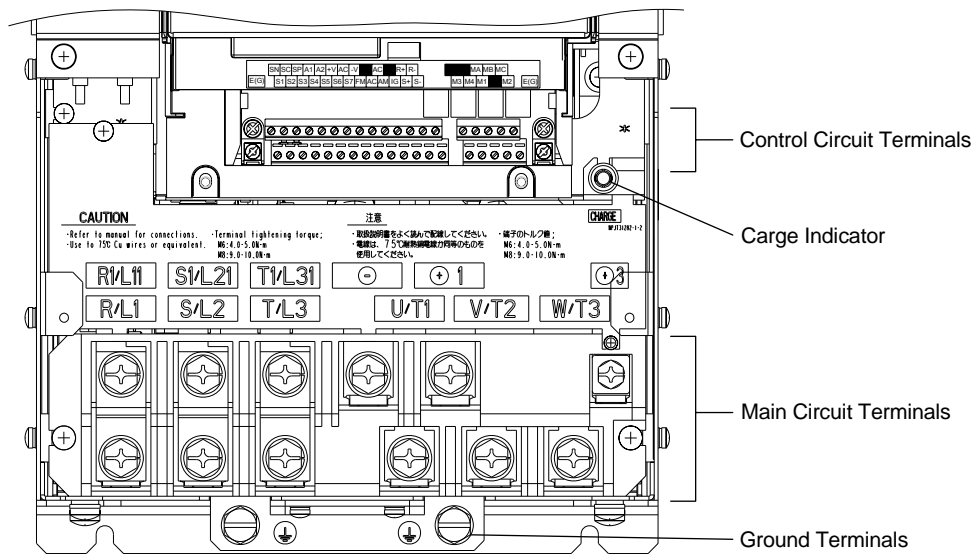

Fig 2.4 Terminal Arrangement (200V / 400V Class Inverter of 22 kW or more)

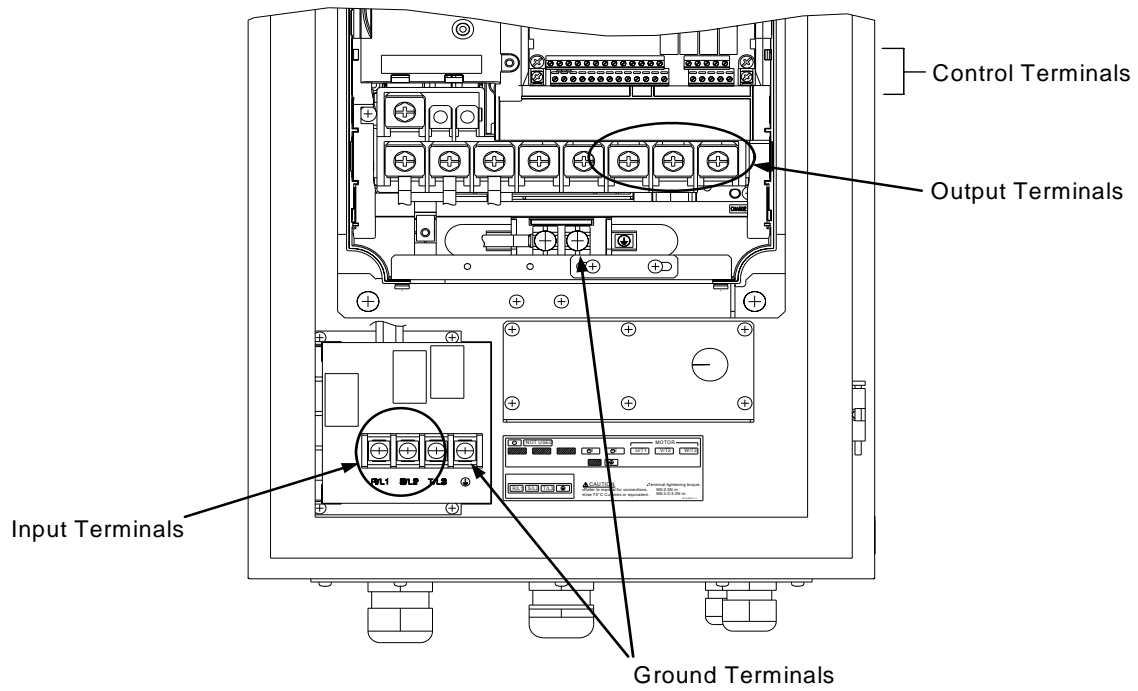

Fig 2.5 Terminal Arrangement (IP54 Inverter of 18.5kW)

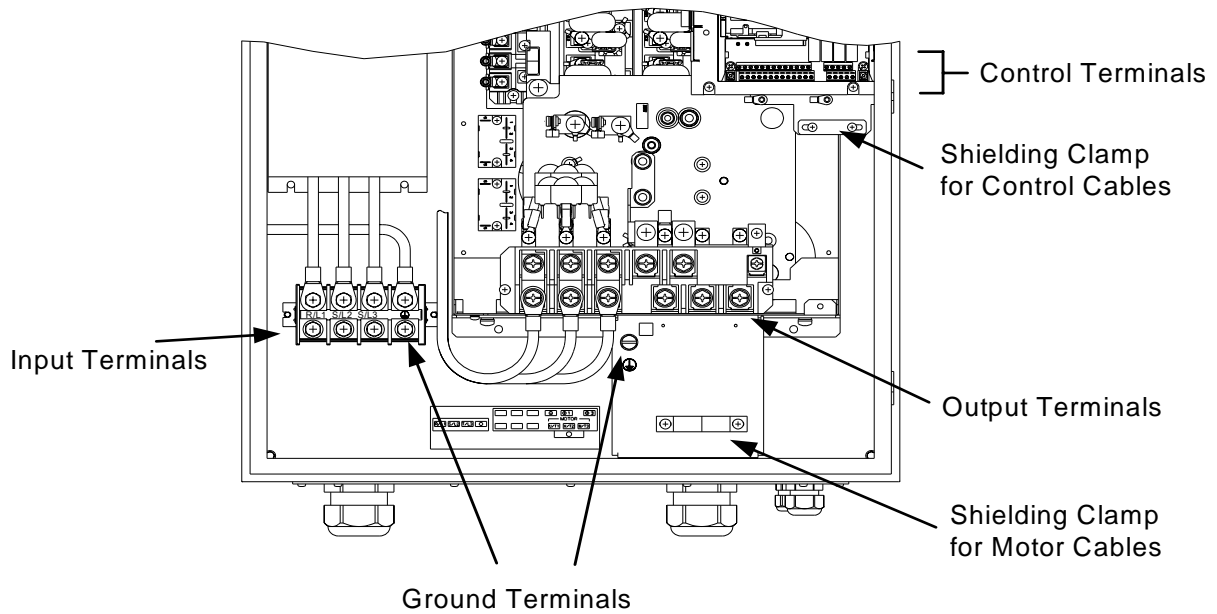

Fig 2.6 Terminal Arrangement (IP54 Inverter of 37kW)

Wiring Main Circuit Terminals

◆ Applicable Wire Sizes and Crimp Terminals

Select the appropriate wires and crimp terminals from the following tables.

Table 2.1 200 V Class Wire Sizes

Inverter Model CIMR-□	Terminal Symbol	Terminal Screws	Tightening Torque (N•m)	Possible Wire Sizes mm ² (AWG)	Recommended Wire Size mm ² (AWG)	Wire Type
E7Z20P4	R/L1, S/L2, T/L3, ⊖, ⊕1, ⊕2, B1, B2, U/T1, V/T2, W/T3	M4	1.2 to 1.5	1.5 to 4 (14 to 10)	2.5 (14)	Power cables, e.g., 600 V vinyl power cables
	⊕					
E7Z20P7	R/L1, S/L2, T/L3, ⊖, ⊕1, ⊕2, B1, B2, U/T1, V/T2, W/T3	M4	1.2 to 1.5	1.5 to 4 (14 to 10)	2.5 (14)	
	⊕					
E7Z21P5	R/L1, S/L2, T/L3, ⊖, ⊕1, ⊕2, B1, B2, U/T1, V/T2, W/T3	M4	1.2 to 1.5	1.5 to 4 (14 to 10)	2.5 (14)	
	⊕					
E7Z22P2	R/L1, S/L2, T/L3, ⊖, ⊕1, ⊕2, B1, B2, U/T1, V/T2, W/T3	M4	1.2 to 1.5	1.5 to 4 (14 to 10)	2 (14)	
	⊕					
E7Z23P7	R/L1, S/L2, T/L3, ⊖, ⊕1, ⊕2, B1, B2, U/T1, V/T2, W/T3	M4	1.2 to 1.5	4 (12 to 10)	4 (12)	
	⊕					
E7Z25P5	R/L1, S/L2, T/L3, ⊖, ⊕1, ⊕2, B1, B2, U/T1, V/T2, W/T3	M4	1.2 to 1.5	6 (10)	6 (10)	
	⊕					
E7Z27P5	R/L1, S/L2, T/L3, ⊖, ⊕1, ⊕2, B1, B2, U/T1, V/T2, W/T3	M5	2.5	10 (8 to 6)	10 (8)	
	⊕					
E7Z2011	R/L1, S/L2, T/L3, ⊖, ⊕1, ⊕2, B1, B2, U/T1, V/T2, W/T3	M5	2.5	16 (6 to 4)	16 (6)	
	⊕					
E7Z2015	R/L1, S/L2, T/L3, ⊖, ⊕1, ⊕2, U/T1, V/T2, W/T3	M6	4.0 to 5.0	25 (4 to 2)	25 (4)	
	B1, B2	M5	2.5	10 (8 to 6)	-	
	⊕	M6	4.0 to 5.0	25 (4)	25 (4)	
E7Z2018	R/L1, S/L2, T/L3, ⊖, ⊕1, ⊕2, U/T1, V/T2, W/T3	M8	9.0 to 10.0	25 to 35 (3 to 2)	25 (3)	
	B1, B2	M5	2.5	10 (8 to 6)	-	
	⊕	M6	4.0 to 5.0	25 (4)	25 (4)	
E7Z2022	R/L1, S/L2, T/L3, ⊖, ⊕1, U/T1, V/T2, W/T3, R1/L11, S1/L21, T1/L31	M8	9.0 to 10.0	25 to 35 (3 to 1)	25 (3)	
	⊕ ₃	M6	4.0 to 5.0	10 to 16 (8 to 4)	-	
	⊕	M8	9.0 to 10.0	25 to 35 (4 to 2)	25 (4)	
E7Z2030	R/L1, S/L2, T/L3, ⊖, ⊕1 U/T1, V/T2, W/T3, R1/L11, S1/L21, T1/L31	M8	9.0 to 10.0	50 (1 to 1/0)	50 (1)	
	⊕ ₃	M6	4.0 to 5.0	10 to 16 (8 to 4)	-	
	⊕	M8	9.0 to 10.0	25 to 35 (4 to 2)	25 (4)	

Table 2.1 200 V Class Wire Sizes

Inverter Model CIMR-□	Terminal Symbol	Terminal Screws	Tightening Torque (N•m)	Possible Wire Sizes mm ² (AWG)	Recommended Wire Size mm ² (AWG)	Wire Type
E7Z2037	R/L1, S/L2, T/L3, ⊖, ⊕1 U/T1, V/T2, W/T3, R1/L11, S1/L21, T1/L31	M10	17.6 to 22.5	70 to 95 (2/0 to 4/0)	70 (2/0)	Power cables, e.g., 600 V vinyl power cables
	⊕3	M8	8.8 to 10.8	6 to 16 (10 to 4)	–	
	⊖	M10	17.6 to 22.5	35 to 70 (2 to 2/0)	35 (2)	
	r/l1, Δ/l2	M4	1.3 to 1.4	0.5 to 4 (20 to 10)	1.5 (16)	
E7Z2045	R/L1, S/L2, T/L3, ⊖, ⊕1 U/T1, V/T2, W/T3, R1/L11, S1/L21, T1/L31	M10	17.6 to 22.5	95 (3/0 to 4/0)	95 (3/0)	
	⊕3	M8	8.8 to 10.8	6 to 16 (10 to 4)	–	
	⊖	M10	17.6 to 22.5	50 to 70 (1 to 2/0)	50 (1)	
	r/l1, Δ/l2	M4	1.3 to 1.4	0.5 to 4 (20 to 10)	1.5 (16)	
E7Z2055	R/L1, S/L2, T/L3, ⊖, ⊕1	M12	31.4 to 39.2	50 to 95 (1/0 to 4/0)	50 × 2P (1/0 × 2P)	
	U/T1, V/T2, W/T3, R1/L11, S1/L21, T1/L31	M10	17.6 to 22.5	90 (4/0)	90 (4/0)	
	⊕3	M8	8.8 to 10.8	6 to 70 (10 to 2/0)	–	
	⊖	M10	17.6 to 22.5	35 to 95 (3 to 4/0)	50 (1/0)	
	r/l1, Δ/l2	M4	1.3 to 1.4	0.5 to 4 (20 to 10)	1.5 (16)	
E7Z2075	R/L1, S/L2, T/L3, ⊖, ⊕1	M12	31.4 to 39.2	95 to 122 (3/0 to 250)	95 × 2P (3/0 × 2P)	
	U/T1, V/T2, W/T3, R1/L11, S1/L21, T1/L31	M10	17.6 to 22.5	95 (3/0 to 4/0)	95 × 2P (3/0 × 2P)	
	⊕3	M8	8.8 to 10.8	6 to 70 (10 to 2/0)	–	
	⊖	M10	17.6 to 22.5	95 to 185 (3/0 to 400)	95 (3/0)	
	r/l1, Δ/l2	M4	1.3 to 1.4	0.5 to 4 (20 to 10)	1.5 (16)	
E7Z2090	R/L1, S/L2, T/L3, ⊖, ⊕1	M12	31.4 to 39.2	150 to 185 (250 to 400)	150 × 2P (250 × 2P)	
	U/T1, V/T2, W/T3, R1/L11, S1/L21, T1/L31			95 to 150 (4/0 to 300)	95 × 2P (4/0 × 2P)	
	⊕3	M8	8.8 to 10.8	6 to 70 (10 to 2/0)	–	
	⊖	M12	31.4 to 39.2	70 to 150 (2/0 to 300)	70 × 2P (2/0 × 2P)	
	r/l1, Δ/l2	M4	1.3 to 1.4	0.5 to 4 (20 to 10)	1.5 (16)	
E7Z2110	R/L1, S/L2, T/L3, ⊖, ⊕1	M12	31.4 to 39.2	240 to 300 (350 to 600)	240 × 2P, or 50 × 4P (350 × 2P, or 1/0 × 2P)	
	U/T1, V/T2, W/T3, R1/L11, S1/L21, T1/L31			150 to 300 (300 to 600)	150 × 2P, or 50 × 4P (300 × 2P, or 1/0 × 4P)	
	⊕3	M8	8.8 to 10.8	6 to 70 (10 to 2/0)	–	
	⊖	M12	31.4 to 39.2	150 (300)	150 × 2P (300 × 2P)	
	r/l1, Δ/l2	M4	1.3 to 1.4	0.5 to 4 (20 to 10)	1.5 (16)	

The wire thickness is set for copper wires at 75°C. The wire thickness is set for copper wires at 75°

Table 2.2 400 V Class Wire Sizes, NEMA 1/ IP20 and IP00 Inverters

Inverter Model CIMR-□	Terminal Symbol	Terminal Screws	Tightening Torque (N•m)	Possible Wire Sizes mm ² (AWG)	Recommended Wire Size mm ² (AWG)	Wire Type
E7Z40P4	R/L1, S/L2, T/L3, ⊖, ⊕1, ⊕2, B1, B2, U/T1, V/T2, W/T3	M4	1.2 to 1.5	1.5 to 4 (14 to 10)	2.5 (14)	Power cables, e.g., 600 V vinyl power cables
	⊕					
E7Z40P7	R/L1, S/L2, T/L3, ⊖, ⊕1, ⊕2, B1, B2, U/T1, V/T2, W/T3	M4	1.2 to 1.5	1.5 to 4 (14 to 10)	2.5 (14)	
	⊕					
E7Z41P5	R/L1, S/L2, T/L3, ⊖, ⊕1, ⊕2, B1, B2, U/T1, V/T2, W/T3	M4	1.2 to 1.5	1.5 to 4 (14 to 10)	2.5 (14)	
	⊕					
E7Z42P2	R/L1, S/L2, T/L3, ⊖, ⊕1, ⊕2, B1, B2, U/T1, V/T2, W/T3	M4	1.2 to 1.5	1.5 to 4 (14 to 10)	2.5 (14)	
	⊕					
E7Z43P7	R/L1, S/L2, T/L3, ⊖, ⊕1, ⊕2, B1, B2, U/T1, V/T2, W/T3	M4	1.2 to 1.5	2.5 to 4 (14 to 10)	4 (12)	
	⊕				2.5 (14)	
E7Z44P0	R/L1, S/L2, T/L3, ⊖, ⊕1, ⊕2, B1, B2, U/T1, V/T2, W/T3	M4	1.2 to 1.5	2.5 to 4 (14 to 10)	4 (12)	
	⊕				2.5 (14)	
E7Z45P5	R/L1, S/L2, T/L3, ⊖, ⊕1, ⊕2, B1, B2, U/T1, V/T2, W/T3	M4	1.2 to 1.5	4 (12 to 10)	4 (12)	
	⊕			2.5 to 4 (14 to 10)	2.5 (14)	
E7Z47P5	R/L1, S/L2, T/L3, ⊖, ⊕1, ⊕2, B1, B2, U/T1, V/T2, W/T3	M4	1.2 to 1.5	6 (10)	6 (10)	
	⊕			4 (12 to 10)	4 (12)	
E7Z4011	R/L1, S/L2, T/L3, ⊖, ⊕1, ⊕2, B1, B2, U/T1, V/T2, W/T3	M5	2.5	6 to 10 (10 to 6)	10 (8)	
	⊕				6 (10)	
E7Z4015	R/L1, S/L2, T/L3, ⊖, ⊕1, ⊕2, B1, B2, U/T1, V/T2, W/T3	M5	2.5	10 (8 to 6)	10 (8)	
	⊕	M5 (M6)	2.5 (4.0 to 5.0)	6 to 10 (10 to 6)	6 (10)	
E7Z4018	R/L1, S/L2, T/L3, ⊖, ⊕1, ⊕2, U/T1, V/T2, W/T3	M6	4.0 to 5.0	10 to 35 (8 to 2)	10 (8)	
	B1, B2	M5	2.5	10 (8)	10 (8)	
	⊕	M6	4.0 to 5.0	10 to 16 (8 to 4)	10 (8)	
E7Z4022	R/L1, S/L2, T/L3, ⊖, ⊕1, ⊕3, U/T1, V/T2, W/T3, R1/L11, S1/L21, T1/L31	M6	4.0 to 5.0	16 (6 to 4)	16 (6)	
	⊕	M8	9.0 to 10.0	16 to 25 (6 to 2)	16 (6)	
E7Z4030	R/L1, S/L2, T/L3, ⊖, ⊕1, ⊕3, U/T1, V/T2, W/T3, R1/L11, S1/L21, T1/L31	M6	4.0 to 5.0	25 (4)	25 (4)	
	⊕	M8	9.0 to 10.0	25 to 35 (4 to 2)	25 (4)	

Table 2.2 400 V Class Wire Sizes, NEMA 1/ IP20 and IP00 Inverters

Inverter Model CIMR-□	Terminal Symbol	Terminal Screws	Tightening Torque (N•m)	Possible Wire Sizes mm ² (AWG)	Recommended Wire Size mm ² (AWG)	Wire Type
E7Z4037	R/L1, S/L2, T/L3, ⊖, ⊕1, U/T1, V/T2, W/T3, R1/L11, S1/L21, T1/L31	M8	9.0 to 10.0	25 to 50 (4 to 1/0)	35 (2)	Power cables, e.g., 600 V vinyl power cables
	⊕3	M6	4.0 to 5.0	10 to 16 (8 to 4)	-	
	⊖	M8	9.0 to 10.0	25 to 35 (4 to 2)	25 (4)	
E7Z4045	R/L1, S/L2, T/L3, ⊖, ⊕1, U/T1, V/T2, W/T3, R1/L11, S1/L21, T1/L31	M8	9.0 to 10.0	35 to 50 (2 to 1/0)	35 (2)	
	⊕3	M6	4.0 to 5.0	10 to 16 (8 to 4)	-	
	⊖	M8	9.0 to 10.0	25 to 35 (4 to 2)	25 (4)	
E7Z4055	R/L1, S/L2, T/L3, ⊖, ⊕1, U/T1, V/T2, W/T3, R1/L11, S1/L21, T1/L31	M8	9.0 to 10.0	50 (1 to 1/0)	50 (1)	
	⊕3	M6	4.0 to 5.0	10 to 16 (8 to 4)	-	
	⊖	M8	9.0 to 10.0	25 to 35 (4 to 2)	25 (4)	
E7Z4075	R/L1, S/L2, T/L3, ⊖, ⊕1	M10	31.4 to 39.2	70 to 95 (2/0 to 4/0)	70 (2/0)	
	U/T1, V/T2, W/T3, R1/L11, S1/L21, T1/L31	M10	17.6 to 22.5	50 to 100 (1/0 to 4/0)	50 (1/0)	
	⊕3	M8	8.8 to 10.8	6 to 16 (10 to 4)	-	
	⊖	M10	31.4 to 39.2	35 to 70 (2 to 2/0)	35 (2)	
	r/11, Δ200/12200, Δ400/12400	M4	1.3 to 1.4	0.5 to 4 (20 to 10)	1.5 (16)	
E7Z4090	R/L1, S/L2, T/L3, ⊖, ⊕1	M10	31.4 to 39.2	95 (3/0 to 4/0)	95 (4/0)	
	U/T1, V/T2, W/T3, R1/L11, S1/L21, T1/L31	M10	17.6 to 22.5	95 (3/0 to 4/0)	95 (4/0)	
	⊕3	M8	8.8 to 10.8	10 to 16 (8 to 4)	-	
	⊖	M10	31.4 to 39.2	50 to 95 (1 to 4/0)	50 (1)	
	r/11, Δ200/12200, Δ400/12400	M4	1.3 to 1.4	0.5 to 4 (20 to 10)	1.5 (16)	
E7Z4110	R/L1, S/L2, T/L3, ⊖, ⊕1 U/T1, V/T2, W/T3, R1/L11, S1/L21, T1/L31	M10	31.4 to 39.2	50 to 95 (1/0 to 4/0)	50 × 2P (1/0 × 2P)	
	⊕3	M8	8.8 to 10.8	10 to 70 (8 to 2/0)	-	
	⊖	M12	31.4 to 39.2	70 to 150 (2/0 to 300)	70 (2/0)	
	r/11, Δ200/12200, Δ400/12400	M4	1.3 to 1.4	0.5 to 4 (20 to 10)	1.5 (16)	
E7Z4132	R/L1, S/L2, T/L3, ⊖, ⊕1 U/T1, V/T2, W/T3, R1/L11, S1/L21, T1/L31	M10	31.4 to 39.2	95 (3/0 to 4/0)	95 × 2P (3/0 × 2P)	
	75 to 95 (2/0 to 4/0)			75 × 2P (2/0 × 2P)		
	⊕3	M8	8.8 to 10.8	10 to 70 (8 to 2/0)	-	
	⊖	M12	31.4 to 39.2	95 to 150 (4/0 to 300)	95 (4/0)	
	r/11, Δ200/12200, Δ400/12400	M4	1.3 to 1.4	0.5 to 4 (20 to 10)	1.5 (16)	

Table 2.2 400 V Class Wire Sizes, NEMA 1/ IP20 and IP00 Inverters

Inverter Model CIMR-□	Terminal Symbol	Terminal Screws	Tightening Torque (N•m)	Possible Wire Sizes mm ² (AWG)	Recommended Wire Size mm ² (AWG)	Wire Type
E7Z4160	R/L1, S/L2, T/L3, ⊖, ⊕1	M12	31.4 to 39.2	95 to 185 (4/0 to 400)	95 × 2P (4/0 × 2P)	
	U/T1, V/T2, W/T3, R1/L11, S1/L21, T1/L31			95 to 185 (3/0 to 400)	95 × 2P (3/0 × 2P)	
	⊕3	M8	8.8 to 10.8	10 to 70 (8 to 2/0)	-	
	⊖	M12	31.4 to 39.2	50 to 150 (1/0 to 300)	50 × 2P (1/0 × 2P)	
	r/l1, Δ200/12200, Δ400/12400	M4	1.3 to 1.4	0.5 to 4 (20 to 10)	1.5 (16)	
E7Z4185	R/L1, S/L2, T/L3	M16	78.4 to 98	95 to 300 (4/0 to 600)	150 × 2P (300 × 2P)	
	U/T1, V/T2, W/T3, R1/L11, S1/L21, T1/L33				120 × 2P (250 × 2P)	
	⊖, ⊕ 1				300 × 2P (600 × 2P)	
	⊕ 3				-	
	⊖				95 × 2P (3/0 × 2P)	
	r/l1, Δ200/12200, Δ400/12400	M4	1.3 to 1.4	0.5 to 4 (20 to 10)	1.5 (16)	
E7Z4220	R/L1, S/L2, T/L3	M16	78.4 to 98	95 to 300 (4/0 to 600)	240 × 2P (500 × 2P)	
	U/T1, V/T2, W/T3, R1/L11, S1/L21, T1/L33				240 × 2P (400 × 2P)	
	⊖, ⊕ 1				120 × 4P (250 × 4P)	
	⊕ 3				-	
	⊖				120 × 2P (250 × 2P)	
	r/l1, Δ200/12200, Δ400/12400	M4	1.3 to 1.4	0.5 to 4 (20 to 10)	1.5 (16)	
E7Z4300	R/L1, S/L2, T/L3	M16	78.4 to 98	95 to 300 (4/0 to 600)	120 × 4P (250 × 4P)	
	R1/L11, S1/L21, T1/L31				120 × 4P (4/0 × 4P)	
	U/T1, V/T2, W/T3				240 × 4P (400 × 4P)	
	⊖, ⊕ 1				-	
	⊕ 3				-	
	⊖				120 × 2P (250 × 2P)	
	r/l1, Δ200/12200, Δ400/12400	M4	1.3 to 1.4	0.5 to 4 (20 to 10)	1.5 (16)	

Power cables,
e.g., 600 V vinyl
power cables

Table 2.3 400 V Class Wire Sizes, IP54 Inverters

Inverter Model CIMR-□	Terminal Symbol	Terminal Screws	Tightening Torque (N•m)	Recom- mended Wire Size mm ² (AWG)	Cable Gland size	Possible Clamp- ing Cable Diam. (mm)	Minimum Diam Over Braid Shield (mm)	
E7Z47P52	INPUT (R/L1, S/L2, T/L3, ⊕)	M5	2.5	6	M32 (Plastic)	11 to 21	-	
	OUTPUT (U/T1, V/T2, W/T3, ⊕)	M4	1.8	6	M32 (Metal)	11 to 21	9.0	
	⊖, ⊕ 1	M4	1.8	6	-	-	-	
E7Z40112	INPUT (R/L1, S/L2, T/L3, ⊕)	M5	2.5	10	M32 (Plastic)	11 to 21	-	
	OUTPUT (U/T1, V/T2, W/T3, ⊕)	M5	2.5	10	M32 (Metal)	11 to 21	9.0	
	⊖, ⊕ 1	M5	2.5	10	-	-	-	
E7Z40152	INPUT (R/L1, S/L2, T/L3, ⊕)	M5	2.5	10	M32 (Plastic)	11 to 21	-	
	OUTPUT	U/T1, V/T2, W/T3 (⊕)	M5 M6	2.5 4.0 to 5.0	10	M32 (Metal)	11 to 21	9.0
	⊖, ⊕ 1	M5	2.5	10	-	-	-	
E7Z40182	INPUT (R/L1, S/L2, T/L3, ⊕)	M5	2.5	10	M32 (Plastic)	11 to 21	-	
	OUTPUT (U/T1, V/T2, W/T3, ⊕)	M6	4.0 to 5.0	10	M32 (Metal)	11 to 21	9.0	
	⊖, ⊕ 1	M6	4.0 to 5.0	10	-	-	-	
E7Z40222	INPUT (R/L1, S/L2, T/L3, ⊕)	M6	4.0 to 5.0	16	M40 (Plastic)	19 to 28	-	
	OUTPUT	U/T1, V/T2, W/T3 (⊕)	M6 M8	4.0 to 5.0 9.0 to 10.0	16	M40 (Metal)	19 to 28	15.0
	⊖, ⊕ 1	M6	4.0 to 5.0	16	-	-	-	
E7Z40302	INPUT (R/L1, S/L2, T/L3, ⊕)	M6	4.0 to 5.0	25	M40 (Plastic)	19 to 28	-	
	OUTPUT	U/T1, V/T2, W/T3 (⊕)	M6 M8	4.0 to 5.0 9.0 to 10.0	25	M40 (Metal)	19 to 28	15.0
	⊖, ⊕ 1	M6	4.0 to 5.0	25	-	-	-	
E7Z40372	INPUT (R/L1, S/L2, T/L3, ⊕)	M8	9.0 to 10.0	35	M50 (Plastic)	19 to 28	-	
	OUTPUT	U/T1, V/T2, W/T3 (⊕)	M8 M8	9.0 to 10.0 9.0 to 10.0	35	M50 (Metal)	19 to 28	-
	⊖, ⊕ 1	M8	9.0 to 10.0	35	-	-	-	
E7Z40452	INPUT (R/L1, S/L2, T/L3, ⊕)	M8	9.0 to 10.0	35	M50 (Plastic)	19 to 28	-	
	OUTPUT	U/T1, V/T2, W/T3 (⊕)	M8 M8	9.0 to 10.0 9.0 to 10.0	35	M50 (Metal)	19 to 28	-
	⊖, ⊕ 1	M8	9.0 to 10.0	35	-	-	-	
E7Z40552	INPUT (R/L1, S/L2, T/L3, ⊕)	M8	9.0 to 10.0	50	M50 (Plastic)	19 to 28	-	
	OUTPUT	U/T1, V/T2, W/T3 (⊕)	M8 M8	9.0 to 10.0 9.0 to 10.0	50	M50 (Metal)	19 to 28	-
	⊖, ⊕ 1	M8	9.0 to 10.0	50	-	-	-	

Table 2.4 Recommended Wire Types for IP54 Inverters

INPUT	4-core Power Cable*1
OUTPUT	4-core shielded Power Cable*1
(-), (+1)	e.g. 600V Vinyl Power Cable

*1. 4-core power cables or 4-core shielded power cables are available e.g. Lappkabel (Ölflex) or Pirelli

Table 2.5 Tightening Torques for Cable Gland

Cable Gland Size	Tightening Torque (Nm)	
	Plastic	Metal
M16	3.0	10.0
M20	6.0	12.0
M25	8.0	12.0
M32	10.0	18.0
M40	13.0	18.0
M50	15.0	20.0

**IMPORTANT**

Determine the wire size for the main circuit so that line voltage drop is within 2% of the rated voltage. Line voltage drop is calculated as follows:

Line voltage drop (V) = $\sqrt{3}$ x wire resistance (W/km) x wire length (m) x current (A) x 10^{-3}

■ Recommended Crimp Terminals

Table 2.6 Recommended Crimp Terminals

Wire Cross Section (mm ²)	Terminal Screws	Recommended Crimp Terminals		
		Klauke®		JST
		a	b	
0.5-1.0	M4	620/4	1620/4	GS4-1
1.5	M4	630/4	1620/4	GS4-1
2.5	M4	630/4	1630/4	GS4-2.5
4	M4	650/4	1650/4	GS4-6
6	M4	650/4	1650/4	GS4-6
	M5	101 R/5	1650/5	GS5-6
	M6	101 R/6	1650/6	GS6-6
	M8	101 R/8	1650/8	GS8-6
10	M5	102 R/5	1652/5	GS5-10
	M6	102 R/6	1652/6	GS6-10
	M8	102 R/8	1652/8	GS8-10
16	M5	103 R/5 ^{*1}	1653/5	GS5-16
	M6	103 R/6	1653/6	GS6-16
	M8	103 R/8	1653/8	GS8-16
25	M6	104 R/6	1654/6	GS6-25
	M8	104 R/8	1654/8	GS8-25
35	M6	105 R/6	1655/6	GS6-35
	M8	105 R/8	1655/8	GS8-35
	M10	105 R/10	1655/10	GS10-35
50	M8	106 R/8	1656/8	GS8-50
	M10	106 R/10	1656/10	GS10-50
	M12	106 R/12	1656/12	GS12-50
70	M8	107 R/8	1657/8	GS8-70
	M10	107 R/10	1657/10	GS10-70
	M12	107 R/12	1657/12	GS12-70
95	M10	108 R/10	1658/10	GS10-95
	M12	108 R/12	1658/12	GS12-95
	M16	108 R/16	1658/16	GS16-95
120	M12	109 R/12	1659/12	GS12-120
	M16	109 R/16	1659/16	GS16-120
150	M12	110 R/12	1660/12	GS12-150
	M16	110 R/16	1660/16	GS16-150
240	M12	112 R/12	1662/12	GS12-240
	M16	112 R/16	1662/16	GS16-240
300	M16	113 R/16	-	-

*1. not applicable for E7Z2011

◆ Main Circuit Terminal Functions

Main circuit terminal functions are summarized according to terminal symbols in [Table 2.7](#). Wire the terminals correctly for the desired purposes.

Table 2.7 Main Circuit Terminal Functions

Purpose	Terminal Symbol	Model: CIMR-E7Z□□□□	
		200 V Class	400 V Class
Main circuit power input	R/L1, S/L2, T/L3	20P4 to 2110	40P4 to 4300
	R1/L11, S1/L21, T1/L31	2022 to 2110	4022 to 4300
Inverter outputs	U/T1, V/T2, W/T3	20P4 to 2110	40P4 to 4300
DC bus terminals	⊕1, ⊖	20P4 to 2110	40P4 to 4300
DC reactor connection	⊕1, ⊕2	20P4 to 2018	40P4 to 4018
Braking Unit connection	⊕3, ⊖	2022 to 2110	4022 to 4300
Ground	⊕	20P4 to 2110	40P4 to 4300

◆ Main Circuit Configurations

The main circuit configurations of the Inverter are shown in [Table 2.8](#)

Table 2.8 Inverter Main Circuit Configurations (IP00, NEMA 1/IP20 Inverters)

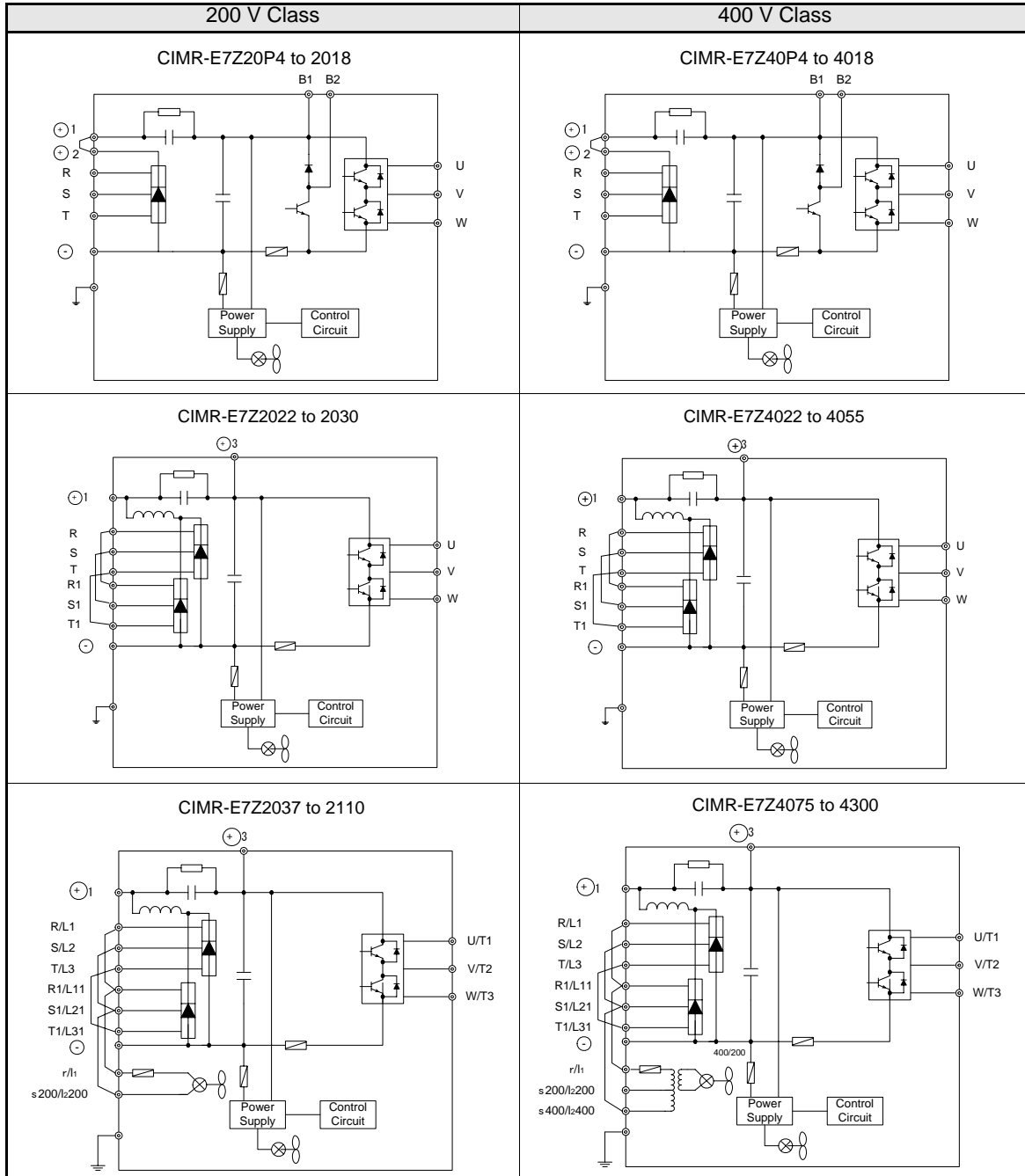

Note: Consult your Omron Yaskawa Motion Control representative before using 12-phase rectification.

Table 2.9 Main Circuit Configurations (IP54 Inverters)

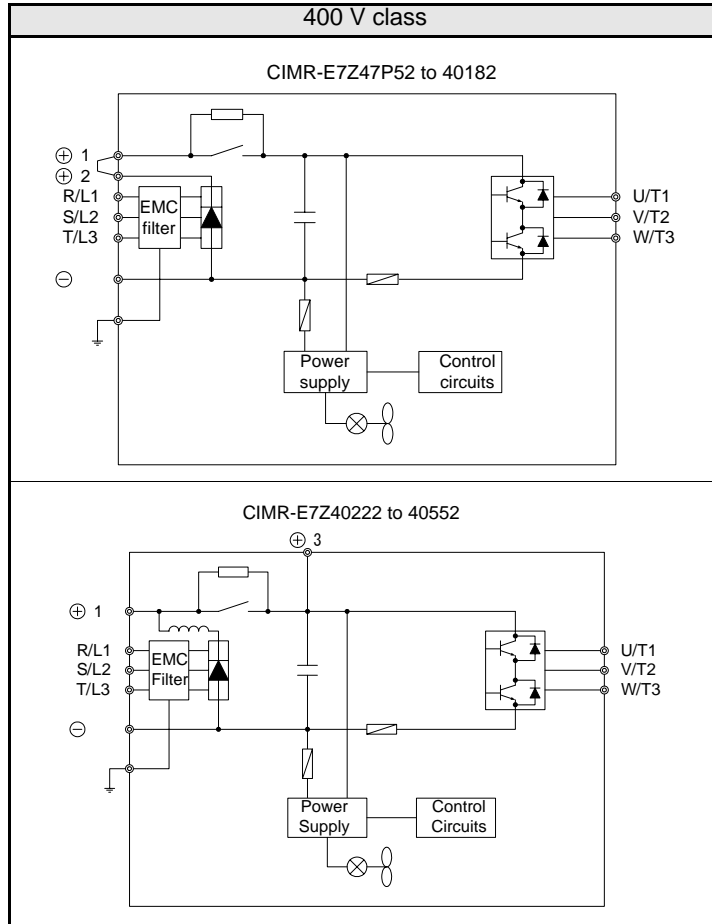

◆ Standard Connection Diagrams

Standard Inverter (NEMA 1 / IP20) connection diagrams are shown in *Fig 2.7*. These are the same for both 200 V Class and 400 V Class Inverters. *Fig 2.8* shows the standard Inverter connection diagrams for the IP54 Inverters. The connections depend on the Inverter capacity.

■ CIMR-E7Z20P4 to 2018 and 40P4 to 4018

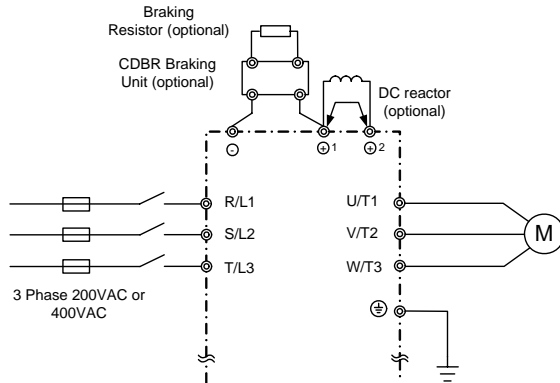

Be sure to remove the short-circuit bar before connecting the DC reactor.

■ CIMR-E7Z2022, 2030 and 4022 to 4055

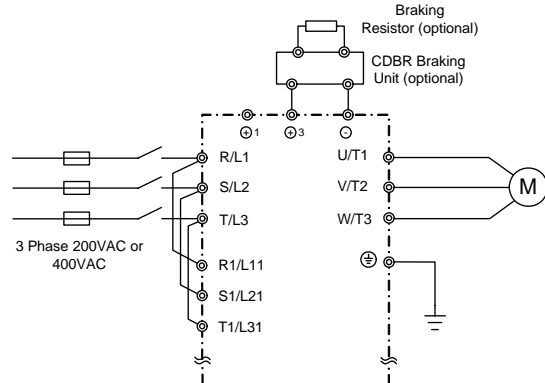

The DC reactor is built in.

■ CIMR-E7Z2037 to 2110

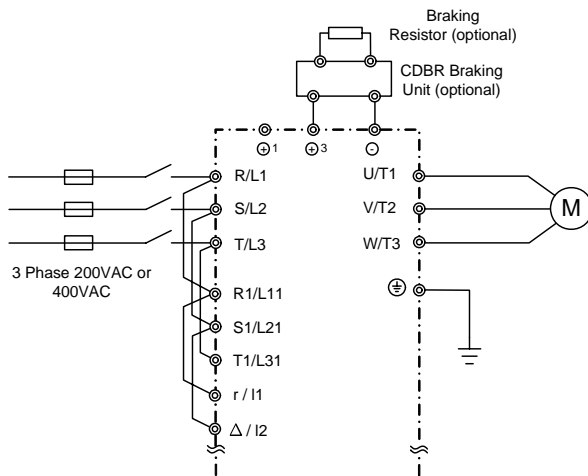

■ CIMR-E7Z4075 to 4300

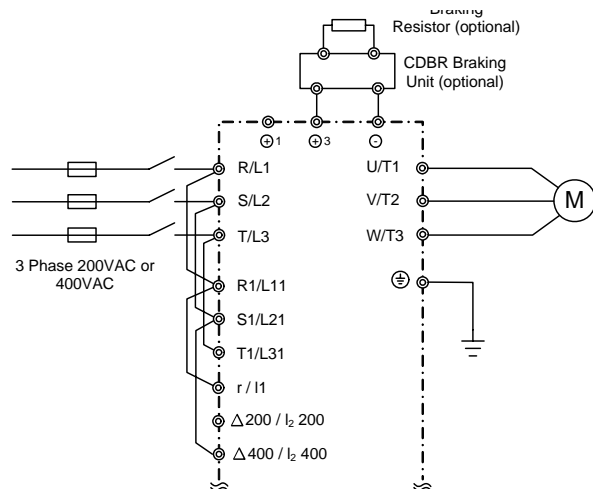

Control power is supplied internally from the DC bus at all inverter models.

Fig 2.7 Main Circuit Terminal Connections for NEMA 1 / IP20 Inverters

■CIMR-E7Z47P72 to 4055

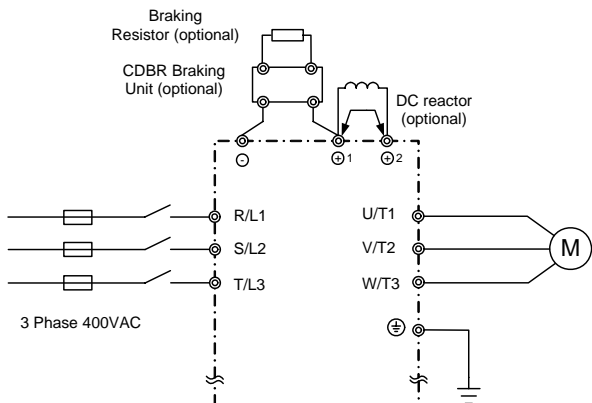

Be sure to remove the short-circuit bar before connecting the DC reactor.

Fig 2.8 Main Circuit Terminal Connections for IP54 Inverters

◆ Wiring the Main Circuits

This section describes wiring connections for the main circuit inputs and outputs.

■ Wiring Main Circuit Inputs

Observe the following precautions for the main circuit power supply input.

Installing Fuses

To protect the inverter, it is recommended to use semiconductor fuses like they are shown in the table below.

Table 2.10 Input Fuses

Inverter Type	Rated Inverter Output Current (A)	Fuse Selection			Selection Example (Ferraz)		
		Voltage (V)	Current (A)	I^2t (A ² s)	Model	Rating	I^2t (A ² s)
20P4	3.2	240	10	12~25	A60Q12-2	600V / 12A	17
20P7	4.1	240	10	12~25	A60Q12-2	600V / 12A	17
21P5	7.0	240	15	23~55	A60Q15-2	600V / 15A	26
22P2	9.6	240	20	34~98	A60Q20-2	600V / 20A	41
23P7	15	240	30	82~220	A60Q30-2	600V / 30A	132
25P5	23	240	40	220~610	A50P50-4	500V / 50A	250
27P5	31	240	60	290~1300	A50P80-4	500V / 80A	640
2011	45	240	80	450~5000	A50P80-4	500V / 80A	640
2015	58	240	100	1200~7200	A50P125-4	500V / 125A	1600
2018	71	240	130	1800~7200	A50P150-4	500V / 150A	2200
2022	85	240	150	870~16200	A50P150-4	500V / 150A	2200
2030	115	240	180	1500~23000	A50P200-4	500V / 200A	4000
2037	145	240	240	2100~19000	A50P250-4	500V / 250A	6200
2045	180	240	300	2700~55000	A50P300-4	500V / 300A	9000
2055	215	240	350	4000~55000	A50P350-4	500V / 350A	12000
2075	283	240	450	7100~64000	A50P450-4	500V / 450A	20000
2090	346	240	550	11000~64000	A50P600-4	500V / 600A	36000
2110	415	240	600	13000~83000	A50P600-4	500V / 600A	36000
40P4	1.8	480	5	6~55	A60Q10-2	600V / 10A	10
40P7	2.1	480	5	6~55	A60Q10-2	600V / 10A	10
41P5	3.7	480	10	10~55	A60Q12-2	600V / 12A	17
42P2	5.3	480	10	18~55	A60Q15-2	600V / 15A	26
43P7	7.6	480	15	34~72	A60Q20-2	600V / 20A	41
44P0	8.7	480	20	50~570	A60Q30-2	600V / 30A	132
45P5	12.5	480	25	100~570	A60Q30-2	600V / 30A	132
47P5	17	480	30	100~640	A60Q30-2	600V / 30A	132
4011	24	480	50	150~1300	A70P50-4	700V / 50A	300
4015	31	480	60	400~1800	A70P70-4	700V / 70A	590
4018	39	480	70	700~4100	A70P80-4	700V / 80A	770
4022	45	480	80	240~5800	A70P80-4	700V / 80A	770
4030	60	480	100	500~5800	A70P100-4	700V / 100A	1200
4037	75	480	125	750~5800	A70P125-4	700V / 125A	1900
4045	91	480	150	920~13000	A70P150-4	700V / 150A	2700
4055	112	480	150	1500~13000	A70P200-4	700V / 200A	4800
4075	150	480	250	3000~55000	A70P250-4	700V / 250A	7500
4090	180	480	300	3800~55000	A70P300-4	700V / 300A	11000
4110	216	480	350	5400~23000	A70P350-4	700V / 350A	15000
4132	260	480	400	7900~64000	A70P400-4	700V / 400A	19000
4160	304	480	450	14000~250000	A70P450-4	700V / 450A	24000
4185	370	480	600	20000~250000	A70P600-4	700V / 600A	43000
4220	506	480	700	34000~400000	A70P700-4	700V / 700A	59000
4300	675	480	900	52000~920000	A70P900-4	700V / 900A	97000

Installing a Moulded-case Circuit Breaker

When connecting the power input terminals (R/L2, S/L2, and T/L3) to the power supply using a moulded-case circuit breaker (MCCB) observe that the circuit breaker is suitable for the Inverter.

- Choose an MCCB with a capacity of 1.5 to 2 times of the inverter's rated current.
- For the MCCB's time characteristics, be sure to consider the inverter's overload protection (one minute at 150% of the rated output current).

Installing an Earth Leakage Breaker

Inverter outputs use high-speed switching, so high-frequency leakage current is generated. If an earth leakage breaker should be used, select a breaker that detects only the leakage current which is in the frequency range that is hazardous to humans but not high-frequency leakage currents.

- For a special-purpose earth leakage breaker for Inverters, choose a ground fault interrupter with a sensitivity amperage of at least 30 mA per Inverter.
- When using a general earth leakage breaker, choose one with a sensitivity amperage of 200 mA or more per Inverter and with an operating time of 0.1 s or more.

Installing a Magnetic Contactor

If the power supply for the main circuit is to be shut off by a control circuit, a magnetic contactor can be used.

The following things should be considered:

- The Inverter can be started and stopped by opening and closing the magnetic contactor on the primary side. Frequently opening and closing the magnetic contactor, however, may cause the Inverter to break down. Do not exceed one power up per hour.
- When the Inverter is operated with the Digital Operator, automatic operation cannot be performed after recovery from a power interruption.

Connecting Input Power Supply to the Terminal Block

Input power supply can be connected to any terminal R, S or T on the terminal block; the phase sequence of input power supply is irrelevant to the output phase sequence.

Installing an Input AC Reactor

If the Inverter is connected to a large-capacity power transformer (600 kW or more) or a phase advancing capacitor is switched nearby, an excessive peak current may flow through the input power circuit, causing the inverter unit to break down.

To prevent this, install an optional AC Reactor on the input side of the Inverter or a DC reactor to the DC reactor connection terminals.

This also improves the power factor on the power supply side.

Installing a Surge Absorber

Always use a surge absorber or diode for inductive loads near the Inverter. These inductive loads include magnetic contactors, electromagnetic relays, solenoid valves, solenoids, and magnetic brakes.

■ Wiring the Output Side of Main Circuit

Observe the following precautions when wiring the main output circuits.

Connecting the Inverter and Motor

Connect output terminals U/T1, V/T2, and W/T3 respective to the motor lead wires U, V, and W.

Check that the motor rotates forward with the forward run command. Switch over any two of the output terminals to each other and reconnect if the motor rotates in reverse with the forward run command.

Never Connect a Power Supply to Output Terminals

Never connect a power supply to output terminals U/T1, V/T2, and W/T3. If voltage is applied to the output terminals, the internal circuits of the Inverter will be damaged.

Never Short or Ground Output Terminals

If the output terminals are touched with bare hands or the output wires come into contact with the Inverter casing, an electric shock or grounding may occur. This is extremely hazardous. Do not short the output wires.

Do Not Use a Phase Advancing Capacitor

Never connect a phase advancing capacitor to an output circuit. The high-frequency components of the Inverter output may overheat and be damaged and may cause other parts to burn.

Using a Magnetic Contactor

Check the control sequence to make sure, that the magnetic contactor (MC) between the Inverter and motor is not turned ON or OFF during inverter operation. If the MC is turned ON while the Inverter is operating, a large inrush current will be created and the inverter's overcurrent protection may operate. If the MC is turned OFF while the Inverter is operating a large induced voltage may occur and damage the inverter output parts.

Installing a Thermal Overload Relay Contact for Motor Protection

This Inverter has an electronic thermal protection function to protect the motor from overheating. If, however, more than one motor is operated with one Inverter or a multi-polar motor is used, always install a thermal relay (THR) between the Inverter and the motor and set L1-01 to 0 (no motor protection). The control circuit should be designed so that the contacts of the thermal overload relay turn OFF the magnetic contactor on the main circuit inputs.

Cable Length between Inverter and Motor

If the cable between the Inverter and the motor is long, the high-frequency leakage current will increase, causing the Inverter output current to increase as well. This may affect peripheral devices. To prevent this, adjust the carrier frequency (set in C6-02) as shown in [Table 2.11](#). (For details, refer to [Chapter 5, User Parameters](#).)

Table 2.11 Cable Length between Inverter and Motor

Cable length	50 m max.	100 m max.	More than 100 m
Carrier frequency	15 kHz max.	10 kHz max.	5 kHz max.

■ Ground Wiring

Observe the following precautions when wiring the ground line.

- Always use the ground terminal of the 200 V Inverter with a ground resistance of less than $100\ \Omega$ and that of the 400 V Inverter with a ground resistance of less than $10\ \Omega$.
- Do not share the ground wire with other devices, such as welding machines or power tools.
- Always use a ground wire that complies with technical standards on electrical equipment and minimize the length of the ground wire.
Leakage current flows through the Inverter. Therefore, if the distance between the ground electrode and the ground terminal is too long, potential on the ground terminal of the Inverter will become unstable.
- When using more than one Inverter, be careful not to loop the ground wire.

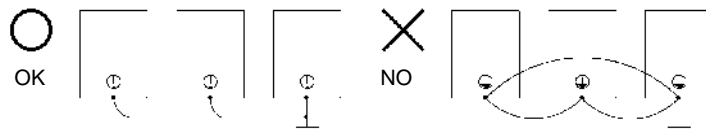

Fig 2.9 Ground Wiring

■ Connecting a Braking Unit (CDBR) and a Braking Resistor Unit (LKEB)

Connect a Braking Unit and a Braking Resistor Unit to the Inverter as shown in the [Fig 2.10](#).

The Braking Resistor Unit will not work if L3-04 is set to 1 (i.e., if stall prevention is enabled for deceleration). Hence the deceleration time may be longer than the set time (C1-02/04).

To prevent the braking unit/braking resistor unit from overheating, design the control circuit to turn OFF the inverter output using the thermal overload relay of the Unit as shown in [Fig 2.10](#).

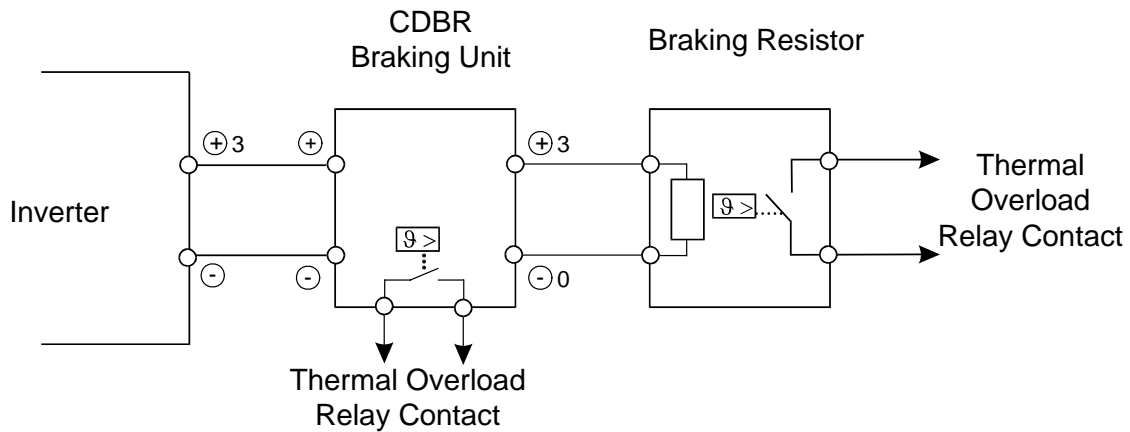

Fig 2.10 Connecting the Braking Resistor Unit and Braking Unit

Connecting Braking Units in Parallel

When connecting two or more Braking Units in parallel, use the wiring and jumper settings like shown in [Fig 2.11](#). There is a jumper for selecting whether each Braking Unit is to be a master or slave. Select “Master” for the first Braking Unit only, and select “Slave” for all other Braking Units (i.e., from the second Unit onwards).

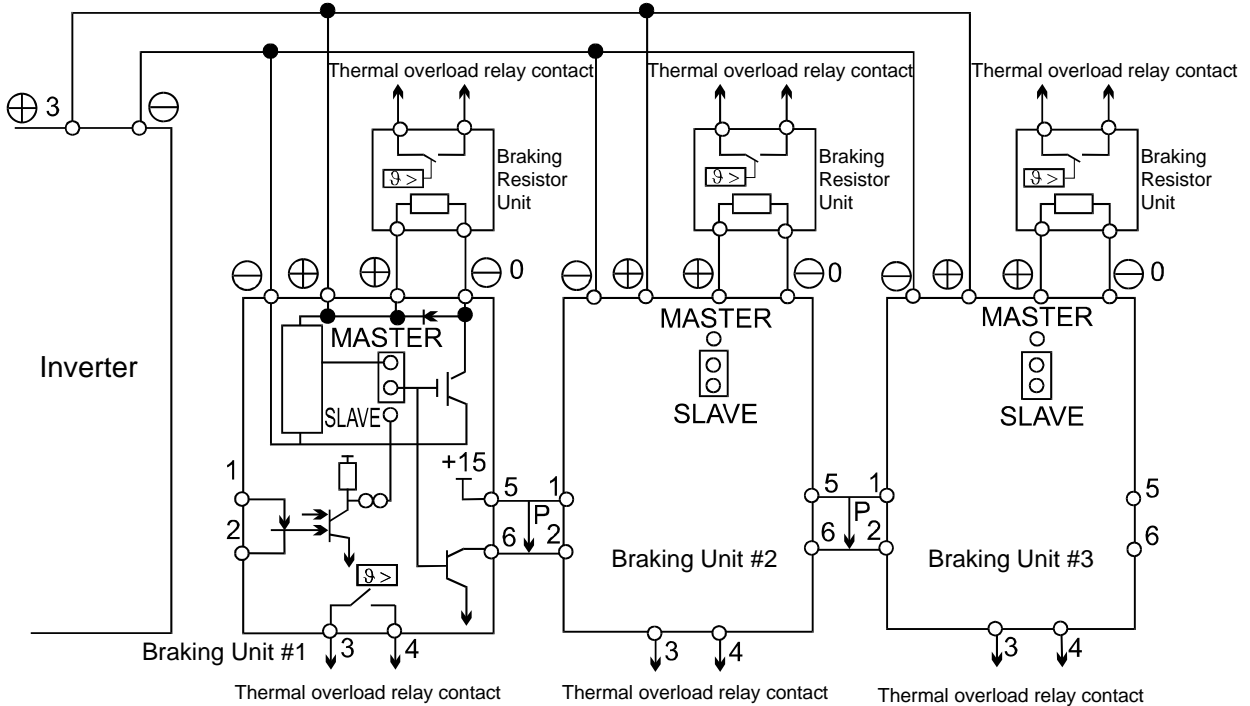

Fig 2.11 Connecting Braking Units in Parallel

■Wiring the Power Cables of IP54 Inverters

Special attention has to be paid for wiring the motor cables of the IP54 inverters. The smaller capacities feature an EMC cable gland which is used to earth the motor cable shield easily.

Installing the Metal (EMC) Cable Gland on IP54 Inverters 7.5 to 30kW

1. With the Standard Contacting:

Make a round cut into the outer sheath, with a length of appr. 14mm from the end of the sheath but do not remove the sheath. Guide the cable through the gland.

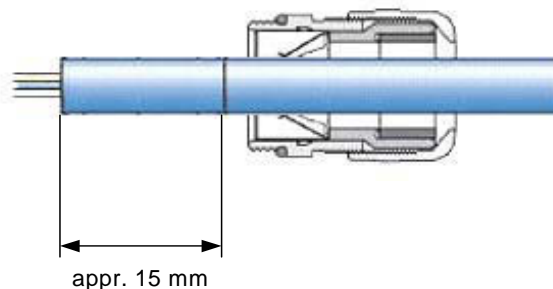

Pull off the cut-off outer sheath, remove some part of the shield and pull the cable back until the shield has proper contact to the springs of the cable gland.

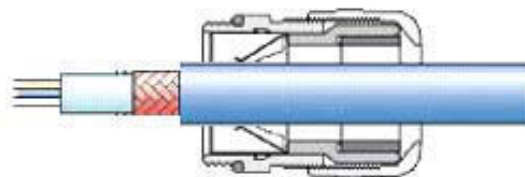

Close the cable gland.

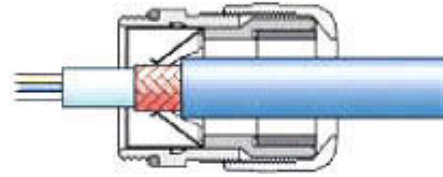

2. With thin wires and without an inner sheath

Make a round cut into the sheath, with a length of appr. 15 to 20mm and remove it.

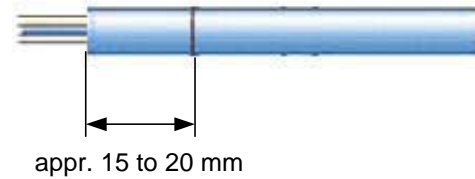

Pull back the braided shield over the outer sheath, the inner shield should be kept for easier guiding through the gland.



Guide the cable through the gland until the shield has proper contact to the springs of the cable gland and close the cable gland.

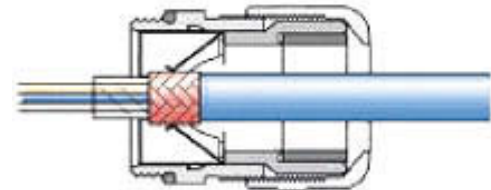

Note:

To ensure conformity to EMC regulations the shielded cable has to be locked tightly by the metal cable gland. Confirm the cable length and the terminal specifications before fitting the metal cable gland.

Special Considerations for IP54 Inverters of 22 and 30kW capacity

Install the shielded output cable as shown in the [Fig 2.12](#).

Remove the braided shield on the output cable entirely from the entry hole to the terminal end to avoid short circuit to the input terminals or the filter.

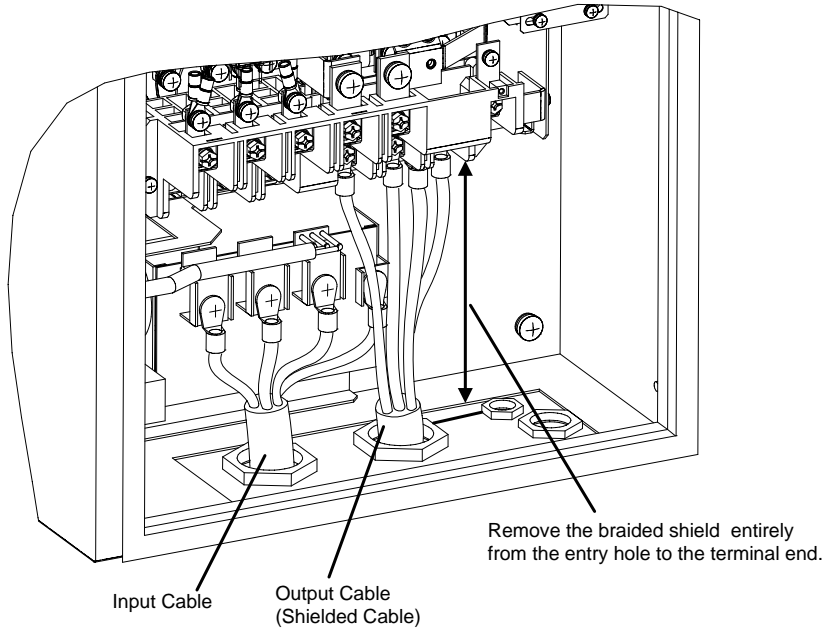

Fig 2.12 Motor Cable Installation for IP54 Inverters of 22 and 30kW

Installing the Motor Cable at IP54 Inverters of 37 to 55kW capacity

Install the shielded output cable as shown in the figure below. Remove the outer sheath and clamp the braided shield by the earth clamp.

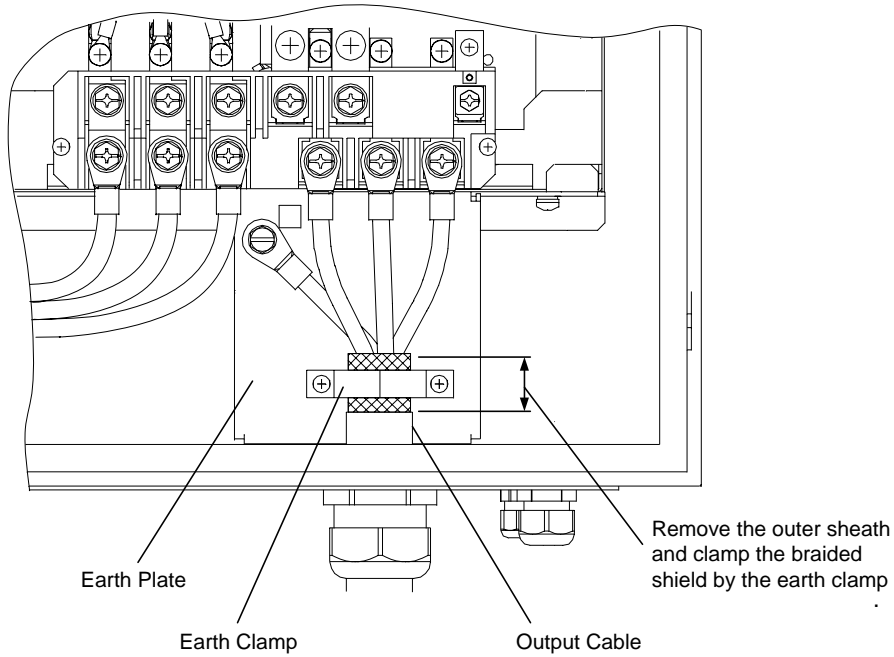

Fig 2.13 Motor Cable Installation for IP54 Inverters of 37 to 55kW

Wiring Control Circuit Terminals

◆ Wire Sizes

For remote operation using analog signals, keep the control line length between the Analog Operator or operation signals and the Inverter to 50 m or less, and separate the lines from main power lines or other control circuits to reduce induction from peripheral devices.

When setting frequencies from an external frequency source (and not from a Digital Operator), use shielded twisted-pair wires and ground the shield for the largest area of contact between shield and ground.

Terminal numbers and wire sizes are shown in [Table 2.12](#).

Table 2.12 Terminal Numbers and Wire Sizes (Same for all models)

Terminals	Terminal Screws	Tightening Torque (N•m)	Possible Wire Sizes mm ² (AWG)	Recommended Wire Size mm ² (AWG)	IP54 Inverters Only		Wire Type
					Cable Gland Size	Possible Clamping Cable Diam. (mm)	
FM, AC, AM, SC, SP, SN, A1, A2, +V, -V, S1, S2, S3, S4, S5, S6, S7 MA, MB, MC, M1, M2, M3, M4, R+, R-, S+, S-, IG	Phoenix type	0.5 to 0.6	Single wire* ¹ : 0.14 to 2.5 Stranded wire: 0.14 to 1.5 (26 to 14)	0.75 (18)	M25* ²	9 to 17	<ul style="list-style-type: none"> • Shielded, twisted-pair wire *³ • Shielded, polyethylene-covered, vinyl sheath cable
E (G)	M3.5	0.8 to 1.0	0.5 to 2 (20 to 14)	1.25 (12)	-	-	

*1. We recommend using cable-end sleeves on signal lines to simplify wiring and to improve reliability.

*2. Refer to [Table 2.5](#) for tightening torques for the cable glands.

*3. Use shielded twisted-pair cables to input an external frequency reference.

■ Cable-End Sleeves for Signal Lines

Models and sizes of straight solderless terminals are shown in the following table.

Table 2.13 Straight Solderless Terminal Sizes

Wire Size mm ² (AWG)	Model	d1	d2	L	Manufacturer
0.25 (24)	AI 0.25 - 8YE	0.8	2	12.5	Phoenix Contact
0.5 (20)	AI 0.5 - 8WH	1.1	2.5	14	
0.75 (18)	AI 0.75 - 8GY	1.3	2.8	14	
1.25 (16)	AI 1.5 - 8BK	1.8	3.4	14	
2 (14)	AI 2.5 - 8BU	2.3	4.2	14	

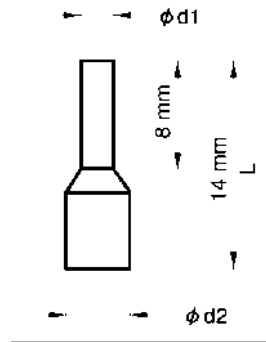

Fig 2.14 Cable-End Sleeve Size

■ Wiring Method

Use the following procedure to connect wires to the terminal block.

1. Loosen the terminal screws with a thin-slot screwdriver.
2. Insert the wires from underneath the terminal block.
3. Tighten the terminal screws firmly

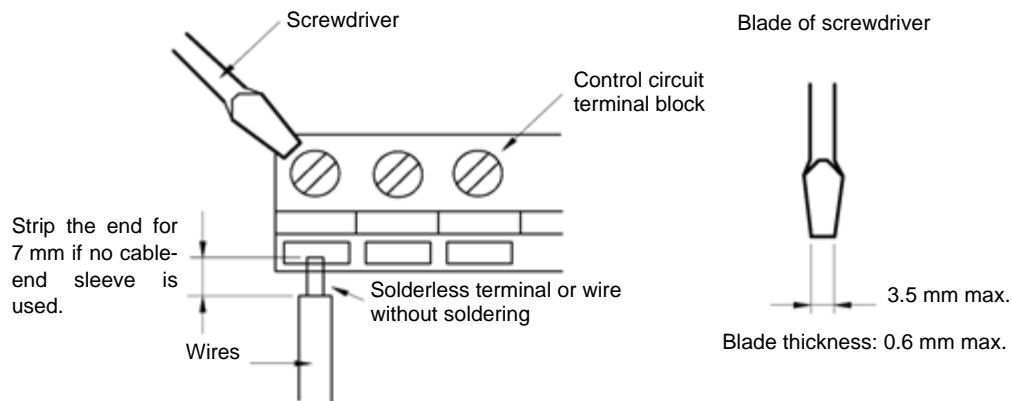

Fig 2.15 Connecting Wires to Terminal Block

■ Earthing the Control Cable Shield in IP54 Inverters

For an appropriate shielding earth clamps have been mounted in the IP54 inverters. *Fig 2.16* and *Fig 2.17* show where the earth clamps can be found.

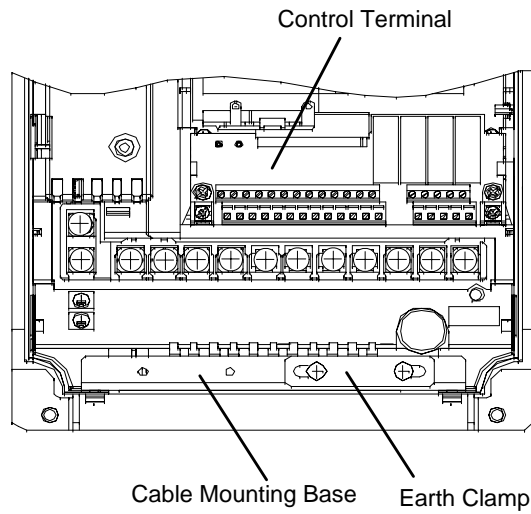

Fig 2.16 Earth Clamp of IP54 Inverters with 7.5 to 18.5kW capacity

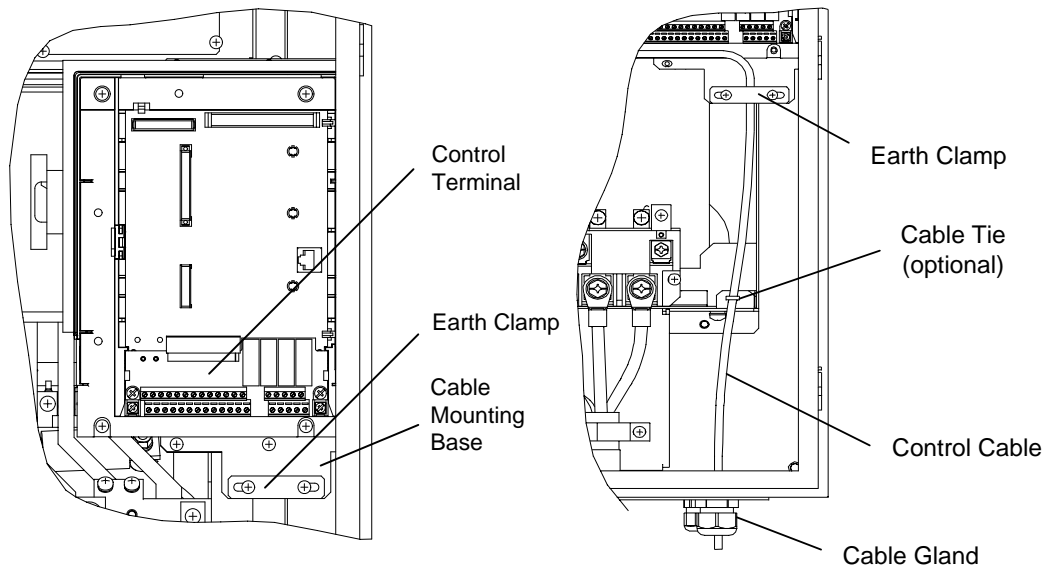
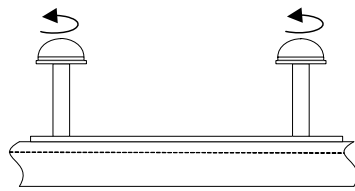
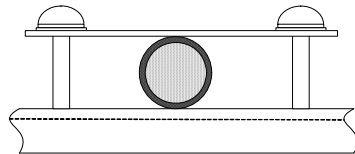

Fig 2.17 Earth clamp of IP54 Inverters with 22 to 55kW

Use the following procedure to clamp and shield the control cables in the IP54 Inverters.



Loosen
both mounting screws for the earth clamp



Insert the shielded cable for control between earth clamp and cable mounting base

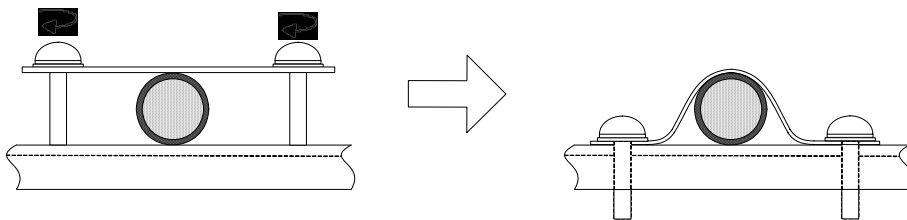

Tighten the screws alternately until screws are fixed to the end.

◆ Control Circuit Terminal Functions

The functions of the control circuit terminals are shown in [Table 2.14](#).

Table 2.14 Control Circuit Terminals with Default Settings

Type	No.	Signal Name	Function		Signal Level	
Digital input signals	S1	Forward run/stop command	Forward run when ON; stopped when OFF.		24 VDC, 8 mA Photocoupler isolation	
	S2	Reverse run/stop command	Reverse run when ON; stopped when OFF.			
	S3	External fault input ^{*1}	Fault when ON.	Functions are selected by setting H1-01 to H1-05.		
	S4	Fault reset ^{*1}	Reset when ON			
	S5	Multi-step speed reference 1 ^{*1} (Master/auxiliary switch)	Auxiliary frequency reference when ON.			
	S6	Multi-step speed reference 2 ^{*1}	Multi-step speed 2 when ON.			
	S7	Jog frequency reference ^{*1}	Jog frequency when ON.			
	SC	Digital input common	-			-
	SN	Digital Input Neutral	-			-
	SP	Digital Input Power Supply	+24VDC power supply for digital inputs			24 VDC, 250 mA max. ^{*2}
Analog input signals	+V	15 V power output	15 V power supply for analog references		15 V (Max. curr.: 20mA)	
	A1	Frequency reference	0 to +10 V/100%		0 to +10 V (20 kΩ)	
	A2	Auxiliary Frequency Reference	Auxiliary analog frequency reference; 4 to 20 mA (250Ω)	Function is selected by setting H3-09.	4 to 20 mA (250Ω) 0 V to +10 V (20kΩ) 0 to 20 mA (250Ω)	
	-V	-15 V power output	-15 V power supply for analog references			
	AC	Analog reference common	-		-	
	E(G)	Shield wire, optional ground line connection point	-		-	
Digital output signals	M1	During run (1NO contact)	Closed during Run	Function selected by H2-01 and H2-02	Relay contacts Contact capacity: 1 A max. at 250 VAC 1 A max. at 30 VDC ^{*3}	
	M2					
	M3	Zero speed (1NO contact)	CLOSED when output frequency at zero level (b2-01) or below			
	M4					
	MA	Fault output signal	CLOSED across MA and MC during faults OPEN across MB and MC during faults			
	MB					
	MC					
analog output signals	FM	Output frequency	Analog output frequency signal; 0 to 10 V; 10V=FMAX	Function selected by H4-01	0 to +10 V max. ±5% 2 mA max.	
	AC	Analog common	-			
	AM	Inverter output power	Analog output power signal; 0 to 10V; 10V=max. appl. motor capacity	Function selected by H4-04		

Table 2.14 Control Circuit Terminals with Default Settings

Type	No.	Signal Name	Function	Signal Level
RS-485/ 422	R+	MEMOBUS communications input	For 2-wire RS-485, short R+ and S+ as well as R- and S-.	Differential input, PHC isolation
	R-			
	S+	MEMOBUS communications output		Differential input, PHC isolation
	S-			
	IG	Signal common		—

- *1. The default settings are given for terminals S3 to S7. For a 3-wire sequence, the default settings are a 3-wire sequence for S5, multi-step speed setting 1 for S6 and multi-step speed setting 2 for S7.
- *2. Do not use this power supply for supplying any external equipment.
- *3. When driving a reactive load, such as a relay coil with DC power supply, always insert a flywheel diode as shown in [Fig 2.18](#)

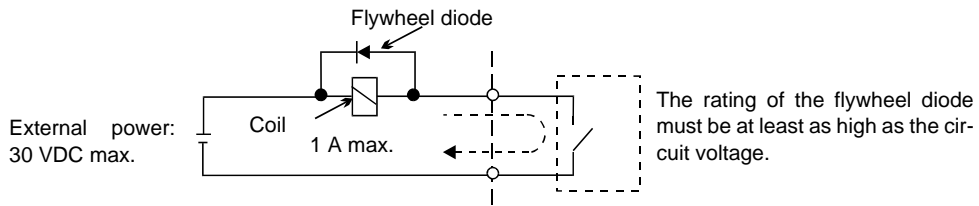

Fig 2.18 Flywheel Diode Connection

■ Switch S1 - Standard Terminal Board

The Switch S1 can be used to terminate the internal RS422/485 port and for selecting the input signal type for analog input A2. See [Fig 2.19](#) for details.

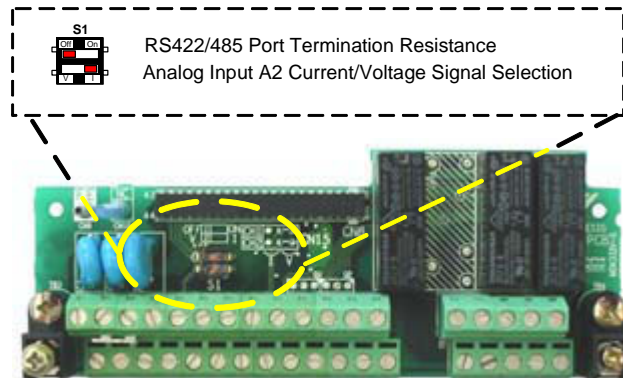

Fig 2.19 Standard terminal board - Switch S1 function

The settings of switch S1 is shown in the following table.

Name	Function	Setting
S1-1	RS-485 and RS-422 terminating resistance	OFF: No terminating resistance ON: Terminating resistance of 110 Ω
S1-2	Input method for analog input A2	V: 0 to 10 V (internal resistance: 20 kΩ) I: 4 to 20 mA (internal resistance: 250 Ω)

Switch S1 and Jumper CN15 - Optional Terminal Board

An optional terminal board which supports switching the signal type of the analog outputs FM and AM between voltage and current is available. The switch over can be performed using jumper CN15. The switch S1 has the same function like on the standard terminal board. See Fig 2.20 for details.

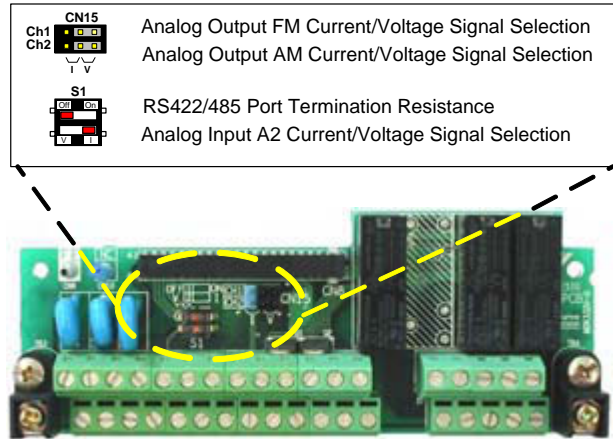

Fig 2.20 Optional terminal board - Switch S1 and jumper CN15 function

The settings of switch S1 and jumper CN15 are described in the following table.

Name	Function	Setting
S1-1	RS-485 and RS-422 terminating resistance	OFF: No terminating resistance ON: Terminating resistance of 110 Ω
S1-2	Input method for analog input A2	V: 0 to 10 V (internal resistance: 20 kΩ) I: 4 to 20 mA (internal resistance: 250 Ω)
CN15-CH1	Multifunction analog output FM voltage/current switch	I: Current output V: Voltage output
CN15-CH2	Multifunction analog output AM voltage/current switch	I: Current output V: Voltage output

Sinking/Sourcing Mode

The input terminal logic can be switched between sinking mode (0-V common, NPN) and sourcing mode (+24V common, PNP) by using the terminals SN, SC, and SP. An external power supply is also supported, providing more freedom in signal input methods.

Table 2.15 Sinking / Sourcing Mode and Input Signals

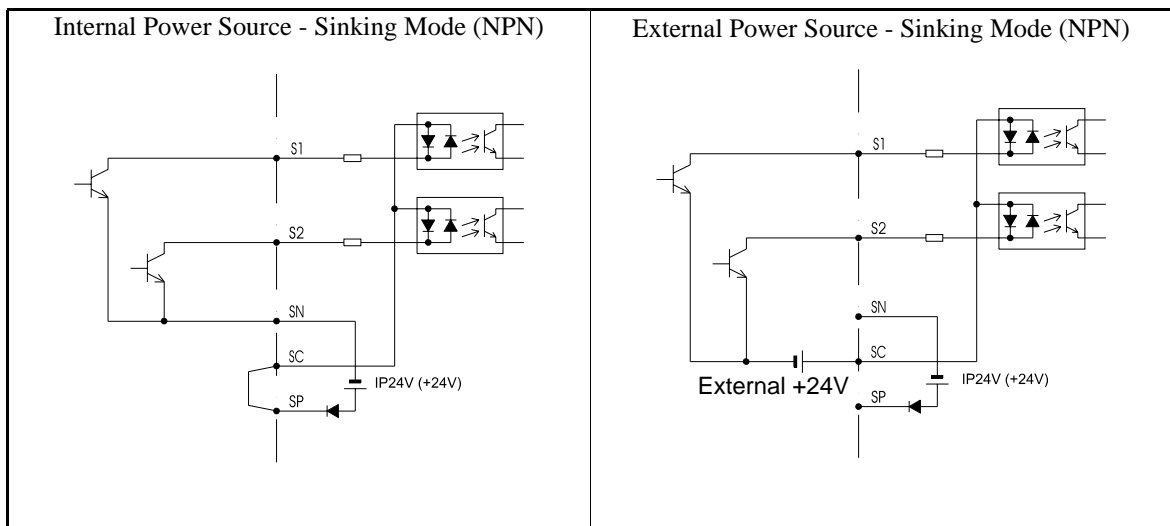
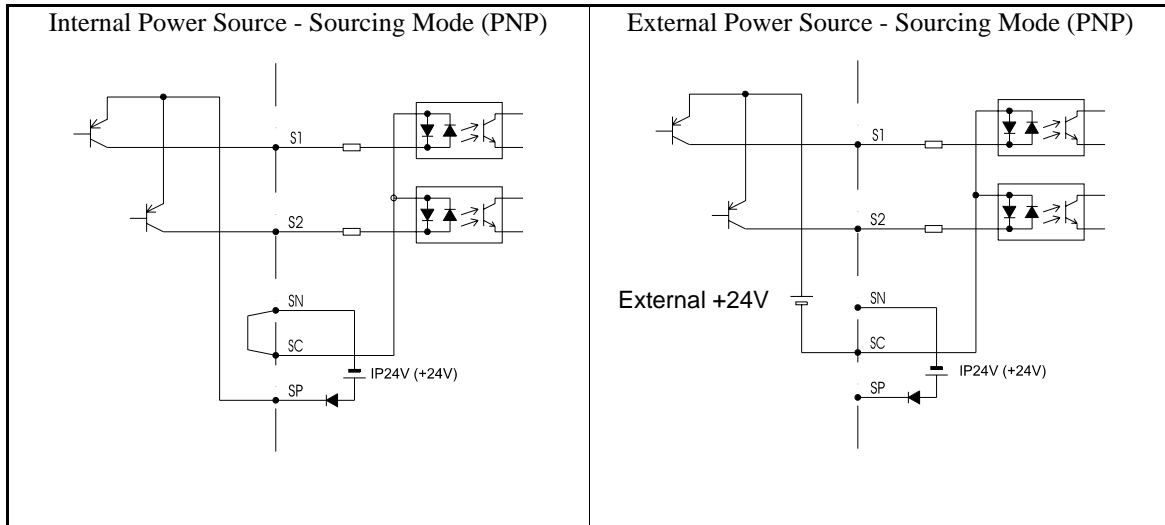

Table 2.15 Sinking / Sourcing Mode and Input Signals



◆ Control Circuit Terminal Connections

Connections to Inverter control circuit terminals are shown in *Fig 2.21*.

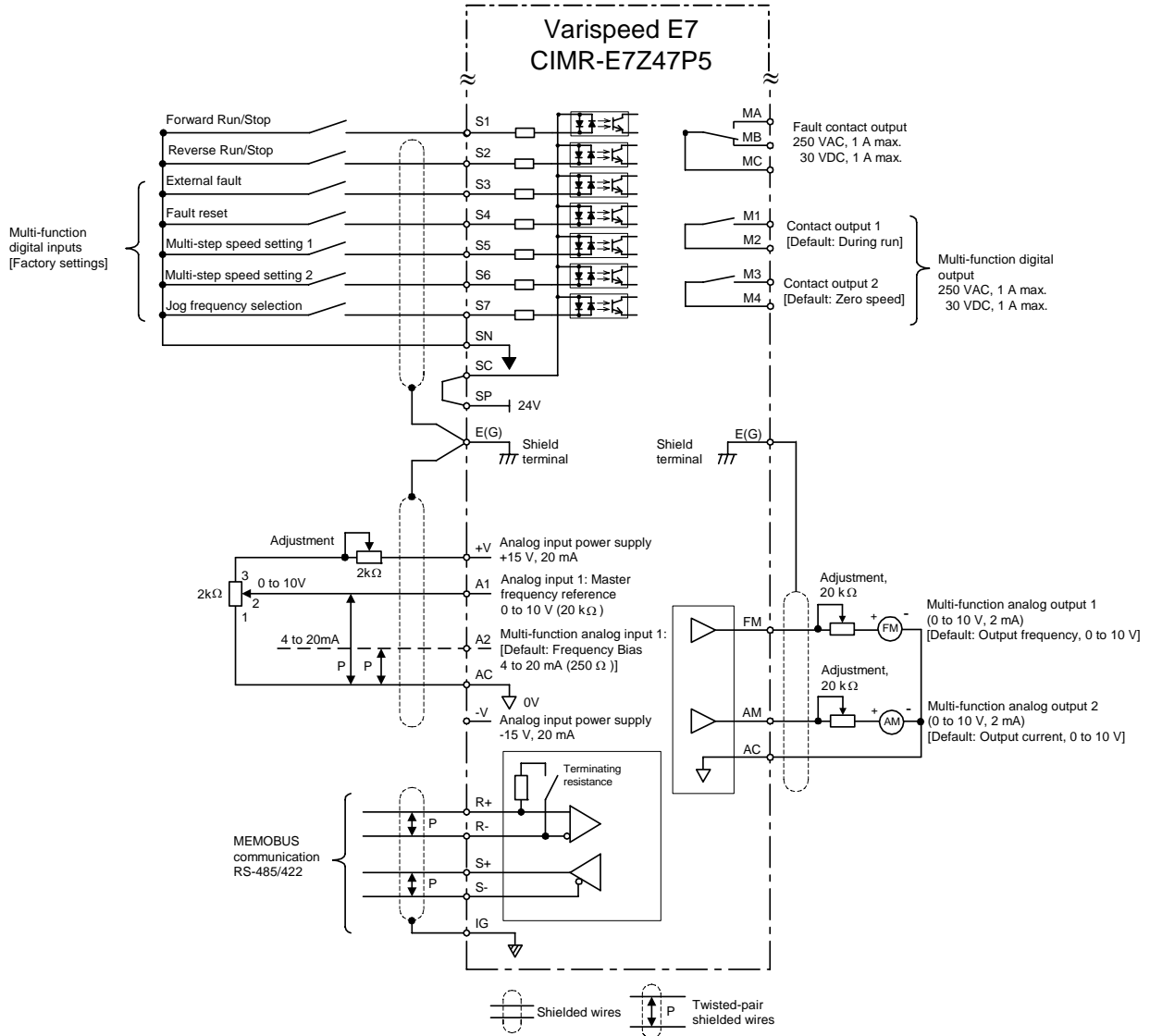

Fig 2.21 Control Circuit Terminal Connections

◆ Control Circuit Wiring Precautions

Observe the following precautions when wiring control circuits.

- Separate control circuit wiring from main circuit wiring (terminals R/L1, S/L2, T/L3, U/T1, V/T2, W/T3, \ominus , $\oplus 1$, $\oplus 2$, and $\oplus 3$) and other high-power lines.
- Separate wiring for control circuit terminals MA, MB, MC, M1, M2, M3, and M4 (relay outputs) from wiring to other control circuit terminals.
- If using an optional external power supply, it shall be a UL Listed Class 2 power supply source.
- Use twisted-pair or shielded twisted-pair cables for control circuits to prevent operating faults.
- Ground the cable shields so as to maximize the contact area of the shield and ground.
- Cable shields have to be grounded on both cable ends.

Wiring Check

◆ Checks

Check all wiring after wiring has been completed. Do not perform continuity check on control circuits. Perform the following checks on the wiring.

- Is all wiring correct?
- Have no wire clippings, screws, or other foreign material been left?
- Are all screws tight?
- Are any wire ends contacting other terminals?



CAUTION

- Ensure that the door locks are closed and the cable glands are tightened after wiring. Otherwise the equipment may be damaged by the ingress of water or dust.
- Keep any water or dust outside of the Inverter when wiring. Otherwise the equipment may be damaged by the ingress of water or dust.
- Use the proper cable gland for each cable. Otherwise the equipment may be damaged by the ingress of water or dust.
- Mount the blind plugs attached for option and control card entry if these terminals are not connected. This will keep IP54 protection for the inverter. Otherwise the equipment may be damaged by the ingress of water or dust.



WARNING

- Be sure to ground the grounding terminal. Moreover be sure to ground the shield of motor cable on the motor side. Otherwise an electric shock can occur.

Installing and Wiring Option Cards

◆ Option Card Models

Option cards for field bus communications can be mounted in the Inverter like shown in [Fig 2.22](#).

[Table 2.16](#) lists the type of Option Cards and their specifications.

Table 2.16 Option Cards

Card	Model	Specifications
Communication cards	3G3RV-PDRT2	Intelligent DeviceNet option card
	SI-P1	Option card for Profibus-DP fieldbus
	SI-R1	Option card for InterBus-S fieldbus
	SI-S1	Option card for CANopen fieldbus
	SI-J	Option card for LONworks
PLC Option Card	3G3RV-P10ST8-E	PLC option card
	3G3RV-P10ST8-DRT-E	PLC option card with DeviceNet communications port (Slave)

◆ Installation in IP00 and NEMA 1 / IP20 Inverters

Before mounting an Option Card, remove the terminal cover and be sure that the charge indicator inside the Inverter does not glow anymore. After that remove the Digital Operator, front cover and the option clip. Then mount the Option Card.

■ Preventing Option Card Connectors from Rising

After installing the Option Card insert the Option Clip to prevent the side with the connector from rising. The Option Clip can be easily removed before installing the card by holding onto the protruding portion of the Clip and pulling it out.

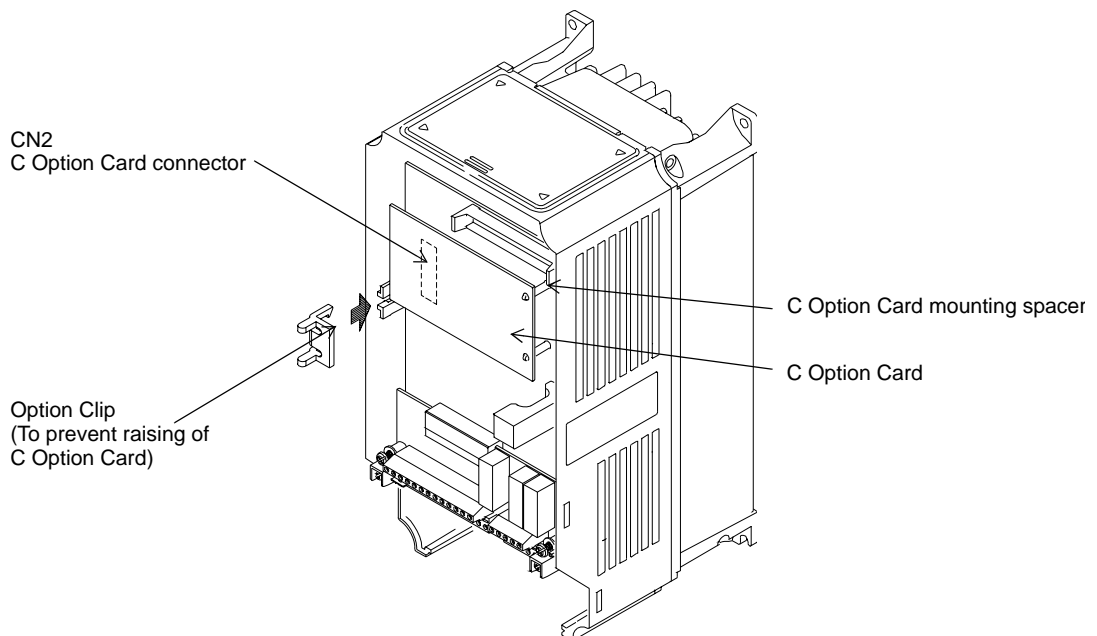

Fig 2.22 Mounting Option Cards

◆ Installation in IP54 Inverters

Before mounting an Option Card, open the inverter door and be sure that the charge indicator inside the Inverter does not glow anymore. After that remove the option clip and mount the Option Card like with the IP00 or NEMA 1 Inverter.

■ Cable Gland Size for Option Cards

Refer to the terminal specification in each option card's manual..

Table 2.17 Cable Gland Size for Option Cards

Cable Gland Size	Possible Clamping Cable Diameter (mm)	Wire Type
M16 ^{*1}	4.5 to 7	<ul style="list-style-type: none"> Shielded twisted-pair wire Shielded, PVC multi-core cable (e.g. Lappkabel Ölflex)

*1. Refer to [Table 2.5](#) for tightening torques for the cable glands.

■ Wiring Method for Option Cards

For the wiring refer to [page 2-29](#) and to [Fig 2.23](#) below.

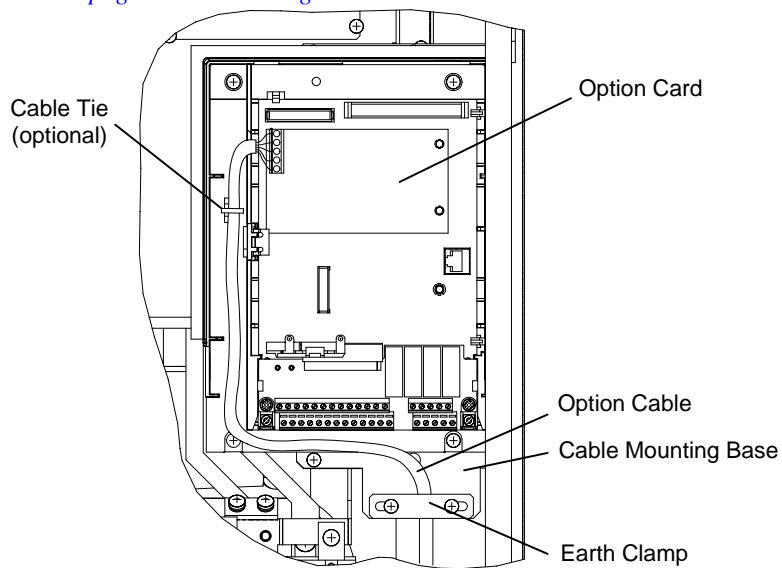

Fig 2.23 Option Card Wiring for Inverters with 22 to 55kW





3

Digital Operator and Modes

This chapter describes Digital Operator displays and functions, and provides an overview of operating modes and switching between modes.

Digital Operator	3-2
Modes	3-5

Digital Operator

This section describes the displays and functions of the Digital Operator.

◆ Digital Operator Display

The key names and functions of the Digital Operator for the IP00 and NEMA 1 / IP20 inverters are described below. This operator is referred to as “LED Digital Operator” or JVOP-161-OY

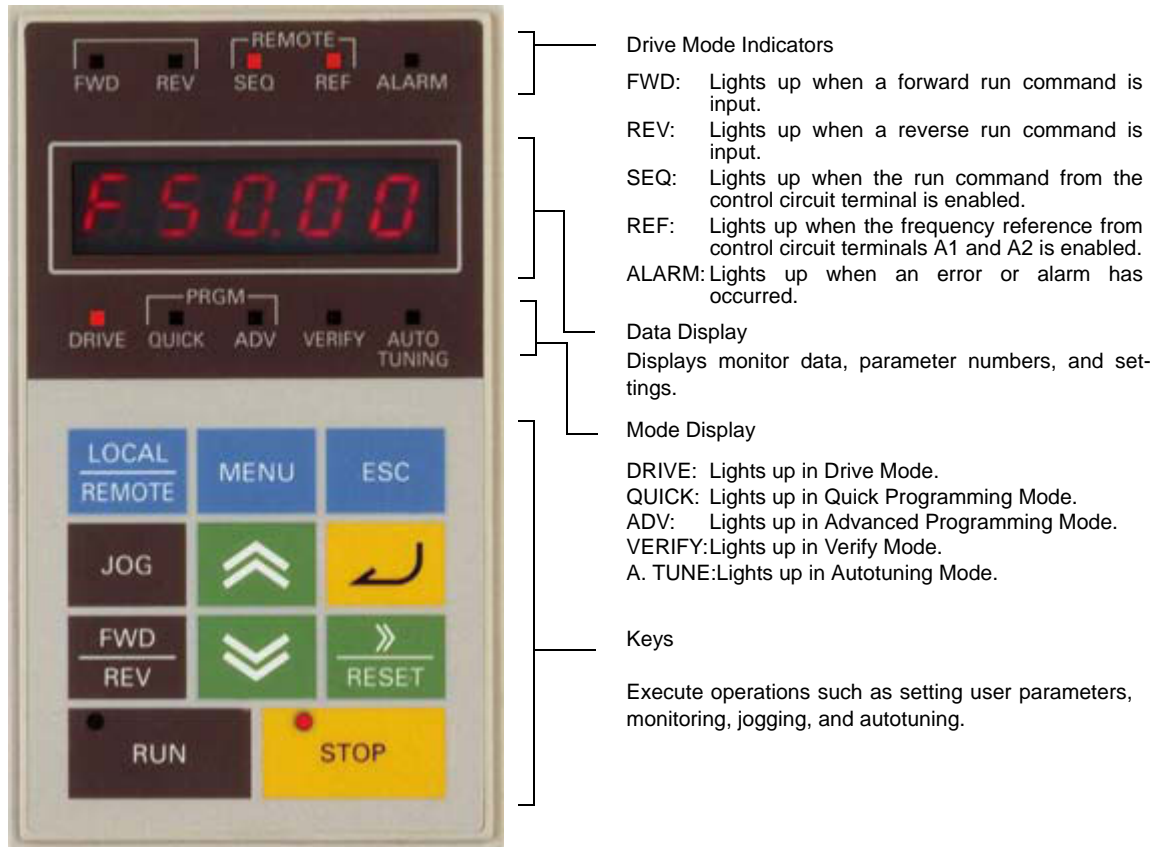

Fig 3.1 LED Digital Operator Component Names and Functions

The IP54 Inverter is equipped with a different type of digital operator, the LCD Digital Operator or JVOP-160-OY. This Operator features a clear text display with 5 lines while the key names and functions are the same, see [Fig 3.2](#). This operator is also available as an option for IP00 and NEMA 1 / IP20 Inverters.

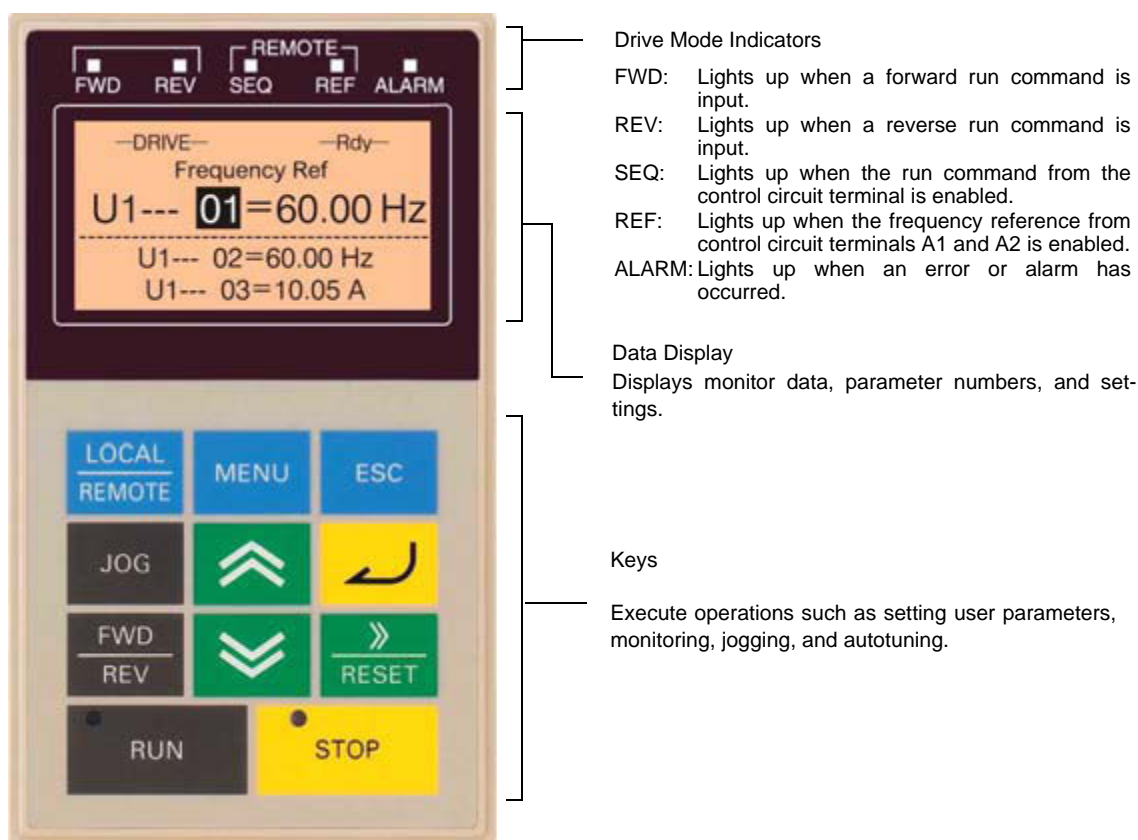

Fig 3.2 LCD Digital Operator Component Names and Functions





◆ Digital Operator Keys

The names and functions of the Digital Operator Keys are described in [Table 3.1](#).

Table 3.1 Key Functions

Key	Name	Function
	LOCAL/REMOTE Key	Switches between operation via the Digital Operator (LOCAL) and the settings in b1-01 and b1-02 (REMOTE). This key can be enabled or disabled by setting parameter o2-01.
	MENU Key	Selects the modes.
	ESC Key	Returns to the status before the DATA/ENTER Key was pressed.
	JOG Key	Enables jog operation when the Inverter is being operated from the Digital Operator.
	FWD/REV Key	Selects the rotation direction of the motor when the Inverter is being operated from the Digital Operator.
	Shift/RESET Key	Sets the active digit when programming user parameters. Also acts as the Reset key when a fault has occurred.

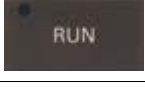
Table 3.1 Key Functions

Key	Name	Function
	Increment Key	Selects user parameter numbers and increments parameter settings. Used to move to the next item or data.
	Decrement Key	Selects user parameter numbers and decrements parameter settings. Used to move to the previous item or data.
	DATA/ENTER Key	Enters menus and parameters and validates parameter settings.
	RUN Key	Starts operation when the Inverter is being controlled by the Digital Operator (LOCAL Mode).
	STOP Key	Stops Inverter operation (LOCAL and REMOTE Mode). This key can be enabled or disabled when operating from a source different than the operator by setting parameter o2-02.

Except in diagrams, Keys are referred to the Key names listed in the above table.

There are indicators on the upper left of the RUN and STOP keys on the Digital Operator. These indicators will light and flash to indicate the operating status.

The RUN key indicator will flash and the STOP key indicator will light while a DC current is injected in the motor. The relationship between the indicators on the RUN and STOP keys and the Inverter status is shown in [Fig 3.3](#).

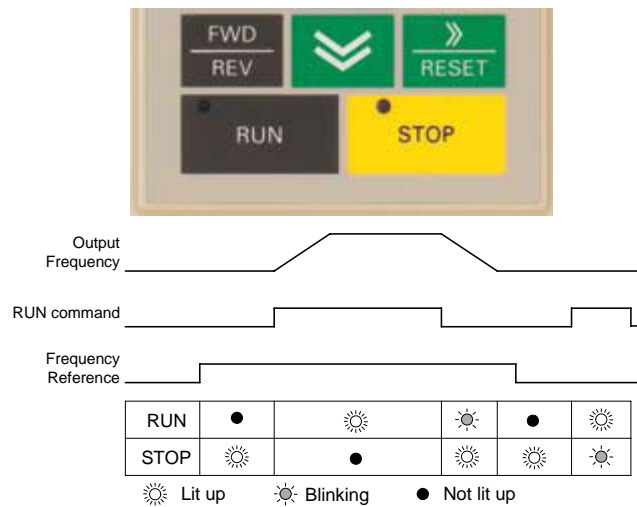

Fig 3.3 RUN and STOP Indicators

Modes

This section describes the Inverter's modes and switching between modes.

◆ Inverter Modes

The Inverter's user parameters and monitoring functions are organized in groups called modes that make it easier to read and set user parameters. The Inverter is equipped with 5 modes.

The 5 modes and their primary functions are shown in the [Table 3.2](#).

Table 3.2 Modes

Mode	Primary function(s)
Drive mode	The Inverter can be run in this mode. Use this mode for monitoring values such as frequency references or output current, displaying fault information and the fault history.
Quick programming mode	Use this mode to read and set the basic user parameters to operate the Inverter.
Advanced programming mode	Use this mode to reference and set all user parameters.
Verify mode	Use this mode to read/set user parameters that have been changed from their factory-set values.
Autotuning mode	Use this mode when running a motor with unknown motor parameters. During Autotuning the line-to-line resistance is measured and set automatically.

◆ Switching Modes

The mode selection display will appear when the MENU key is pressed from any other operator display. Press the MENU key to switch between the different modes.

When the DATA/ENTER key is pressed the monitor display is entered. Depending on the entered menu the monitor data or parameters are displayed.

■ Example Operations with LED Digital Operator

Fig 3.4 shows the mode transition appearance with the LED digital operator.

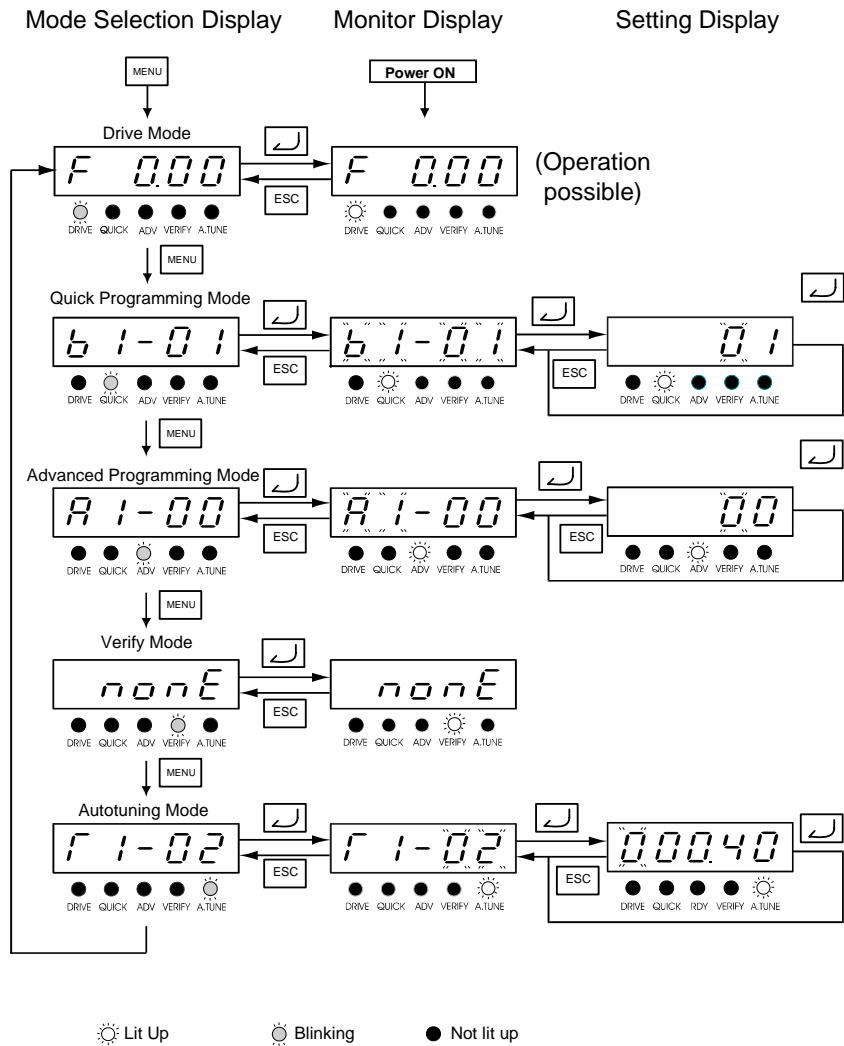

Fig 3.4 Mode Transitions with LED Digital Operator

Example Operations with LCD Digital Operator

Fig 3.5 shows the mode transition appearance with the LCD digital operator.

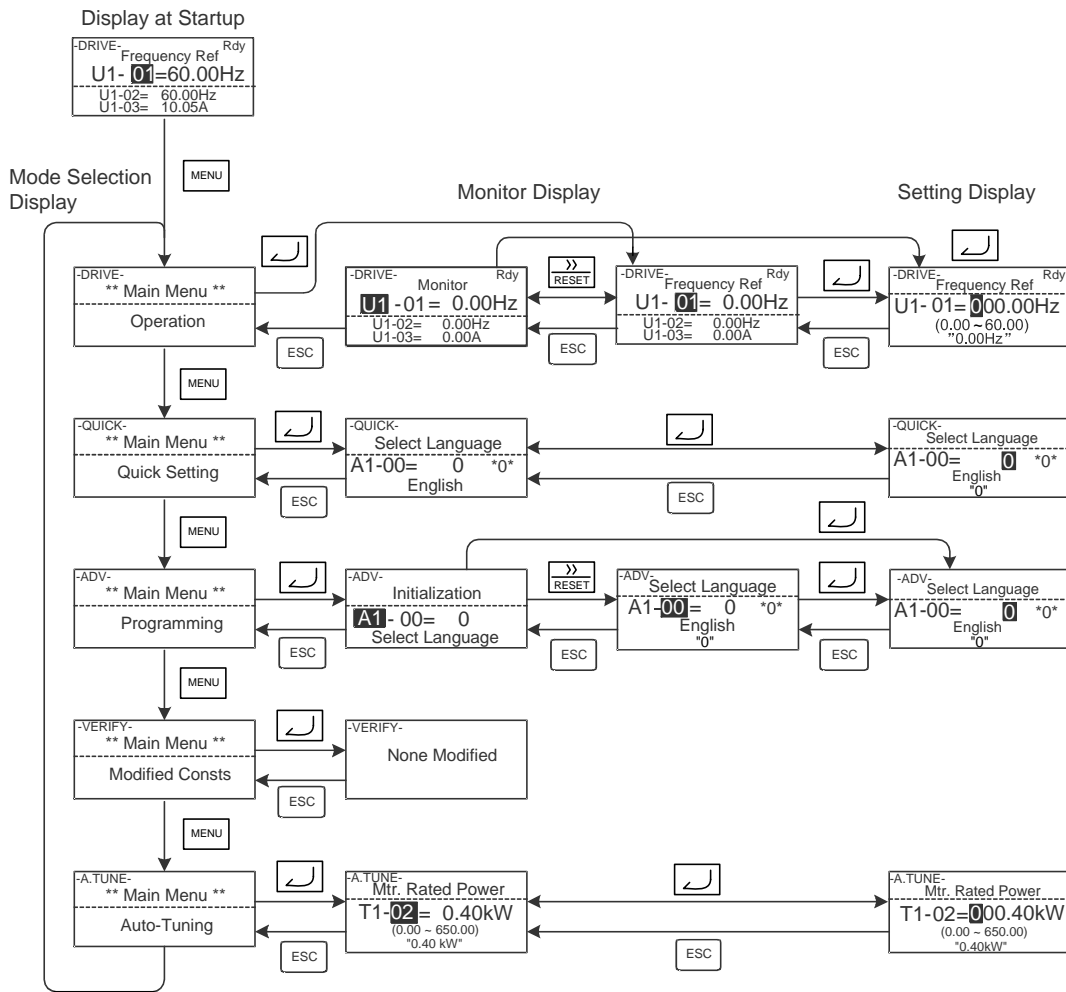

Fig 3.5 Mode Transitions with LCD Digital Operator

◆ Drive Mode

The Inverter can be operated in the Drive Mode. Monitor parameters, fault information and the fault history parameters can be displayed.

When b1-01 (Reference selection is set to 0, the frequency reference can be changed from the frequency setting display. Use the Increment, Decrement and Shift/RESET keys to change it. The set value will be accepted when the DATA/ENTER key has been pressed.

■ Example Operations with LED Digital Operator

Fig 3.6 shows mode transition examples with the LED digital operator.

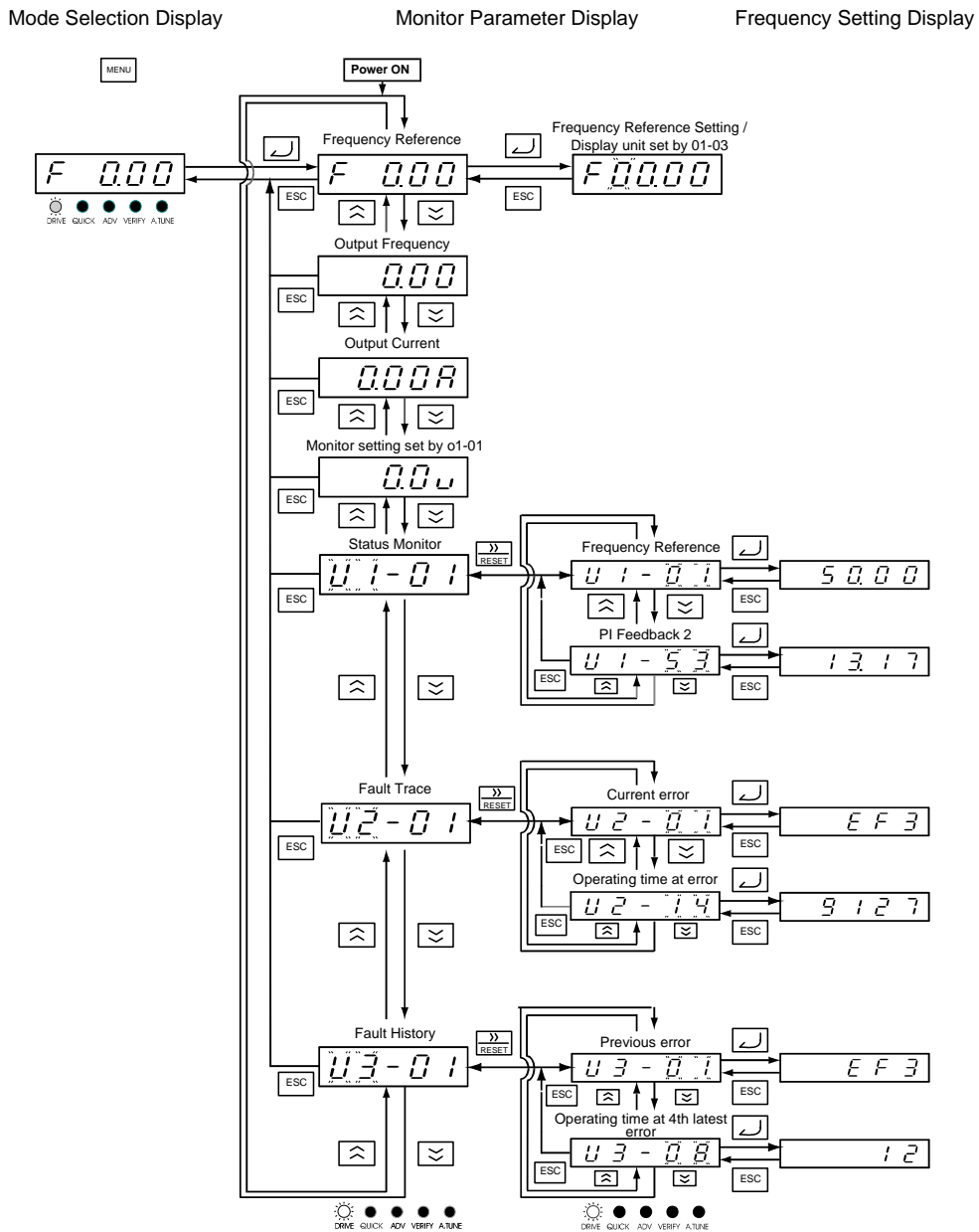

Fig 3.6 Operations in Drive Mode with LED Digital Operator

Example Operations with LCD Operator

Fig 3.7 shows mode transition examples with the LCD digital operator.

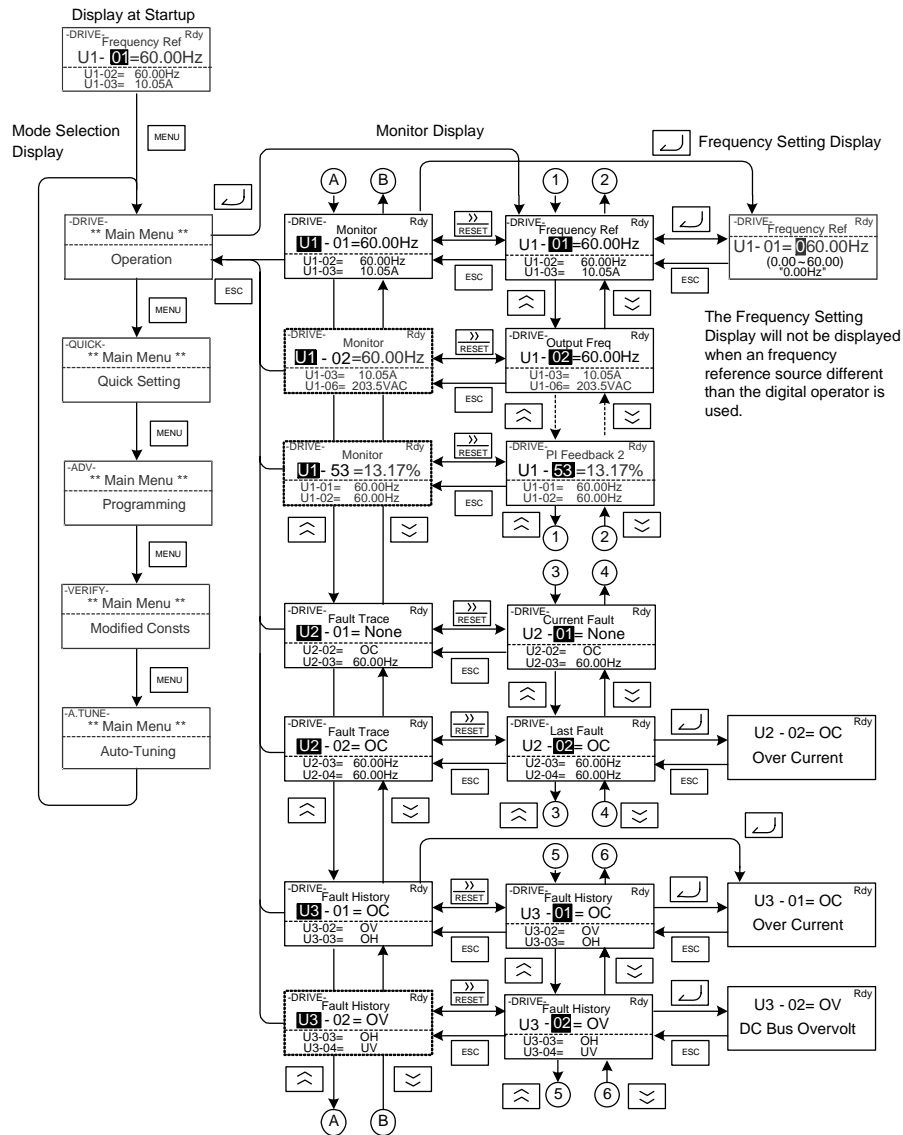

Fig 3.7 Operations in Drive Mode with LCD Digital Operator



To run the Inverter after viewing/changing parameters press the MENU key and the DATA/ENTER key in sequence to enter the Drive mode. A Run command is not accepted as long as the Inverter in any other display.
 To enable Run commands from other sources during programming set parameter b1-08 to “1”.

Quick Programming Mode

In Quick Programming Mode, the basic parameters required for Inverter trial operation can be monitored and set.

The parameters can be changed in the setting displays. Use the Increment, Decrement and Shift/RESET keys to change the settings. The setting will be saved and the display will return to the monitor display when the DATA/Enter key is pressed.

Refer to *Chapter 5, User Parameters* for details on the parameters displayed in Quick Programming Mode.

■ Example Operations with LED Digital Operator

Fig 3.8 shows example operations in Quick Programming Mode with the LED Digital Operator.

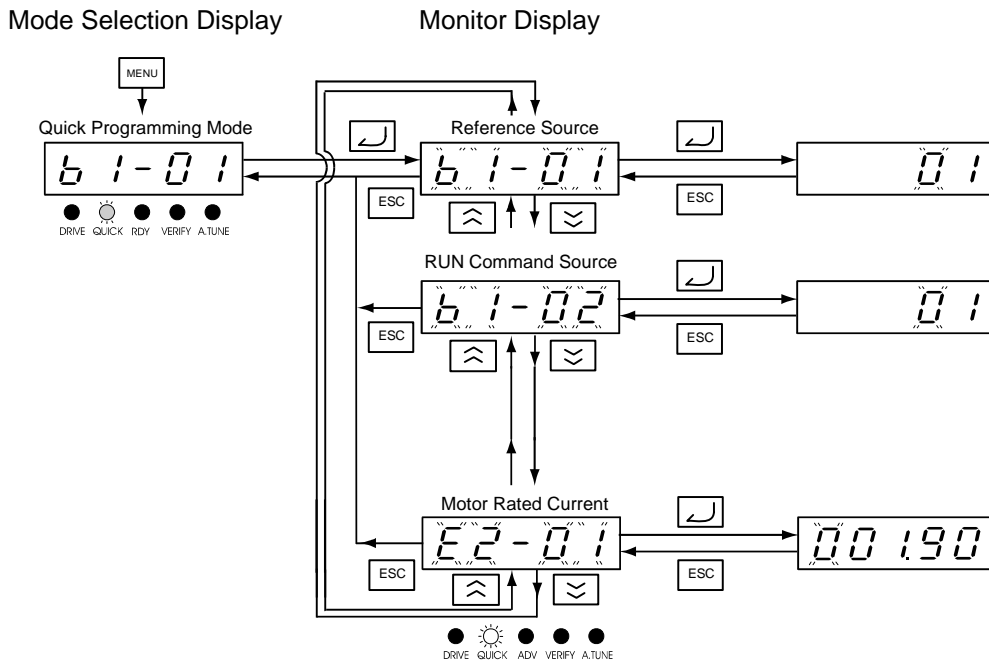

Fig 3.8 Operations in Quick Programming Mode with LED Digital Operators

■ Example Operations with LCD Operator

Fig 3.9 shows example operations in Quick Programming Mode using the LCD Digital Operator.

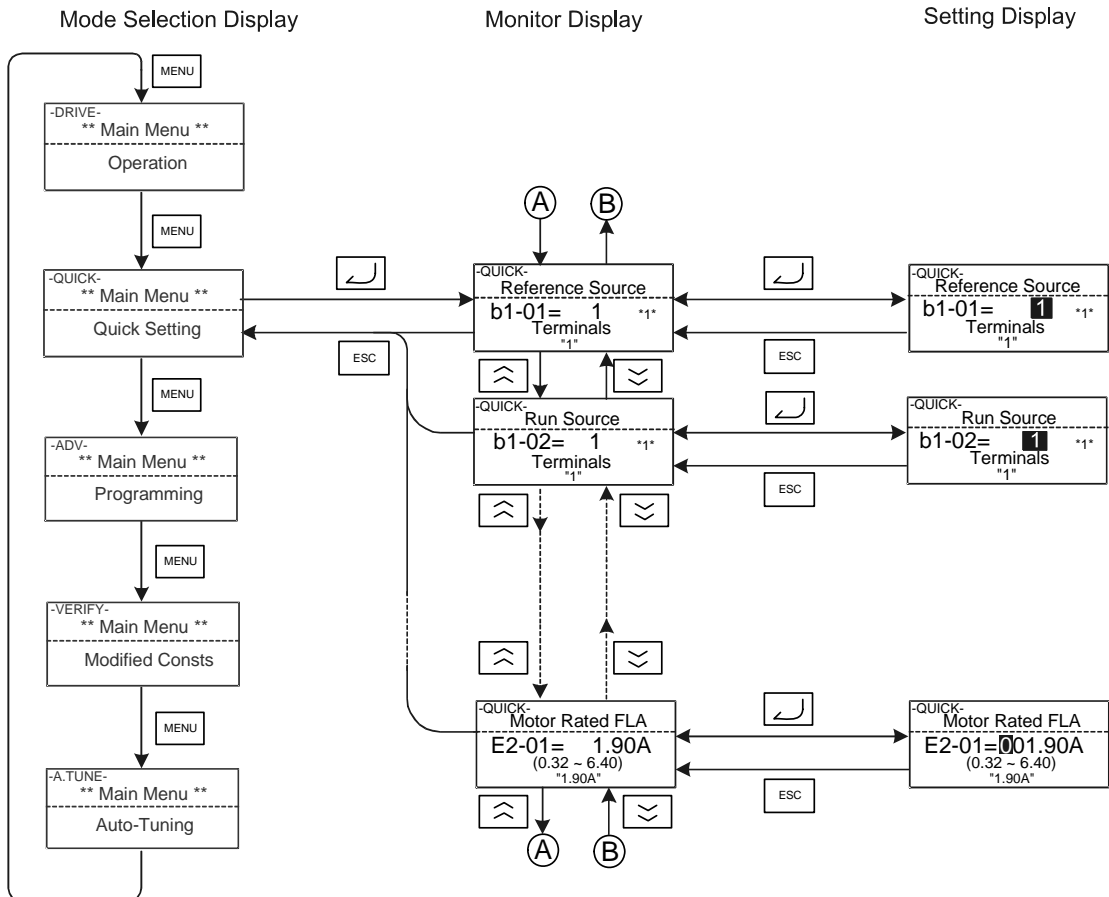

Fig 3.9 Operations in Quick Programming Mode with LCD Digital Operators

◆ Advanced Programming Mode

In Advanced Programming Mode all parameters can be monitored and set.

The parameters can be changed from the setting display. Use the Increment, Decrement, and Shift/RESET keys to change the settings. The setting will be saved and the display will return to the monitor display when the DATA/Enter key is pressed.

Refer to *Chapter 5, User Parameters* for details on the parameters.

■ Example Operations with LED Digital Operator

Fig 3.10 shows example operations in Advanced Programming Mode with the LED Digital Operator.

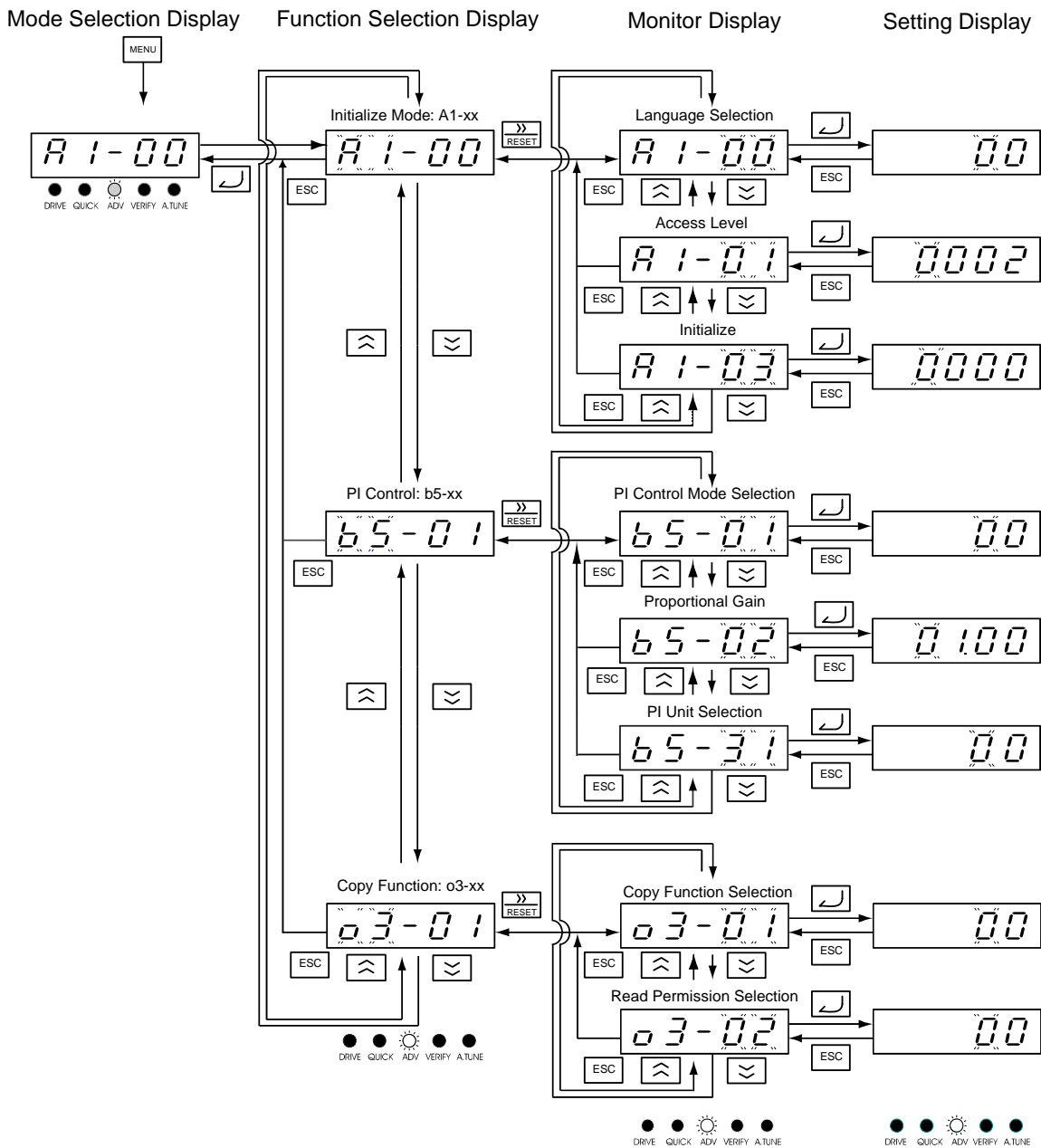

Fig 3.10 Operations in Advanced Programming Mode with LED Digital Operator

■ Example Operations with LCD Digital Operator

Fig 3.11 shows example operations in Advanced Programming Mode using the LCD Digital Operator.

Mode Selection Display

Monitor Display

Setting Display

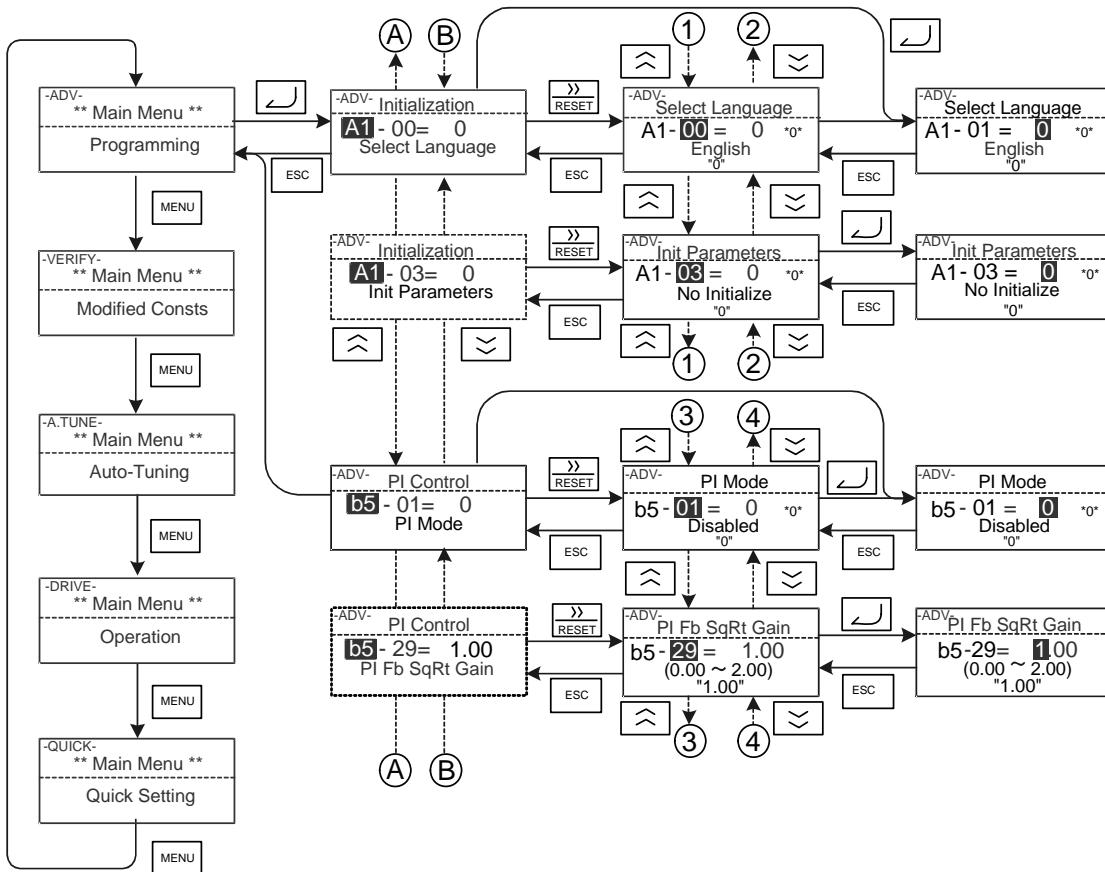
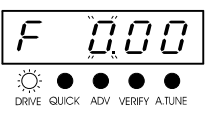
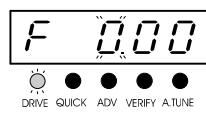
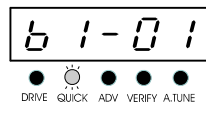
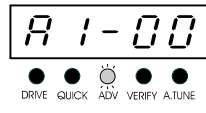
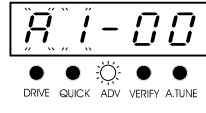
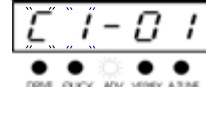



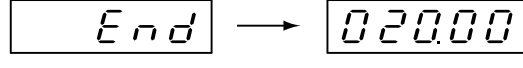
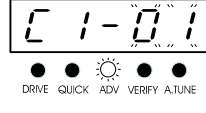

Fig 3.11 Operations in Advanced Programming Mode with LCD Digital Operator

■ Setting User Parameters using the LED Digital Operator

Below in [Table 3.3](#) the procedure to change C1-01 (Acceleration Time 1) from 10 sec. to 20 sec. is shown using the LED Digital Operator.

Table 3.3 Setting User Parameters in Advanced Programming Mode using the LED Digital Operator

Step No.	Digital Operator Display	Description
1		Power supply turned ON.
2		Press the MENU key to enter the Mode Selection Display.
3		Press the MENU key to scroll through the Mode Selection Display.
4		
5		Press the DATA/ENTER key to access the Monitor Display in Advanced Programming Mode.
6		Press the Increment or Decrement key until C1-01 (Acceleration Time 1) is displayed.
7		Press the DATA/ENTER key to access the setting display. The setting can be changed now.
8		Press the Shift/RESET key to move the flashing digit to the right.
9		Press the Decrement key to change the value to 20.00sec.
10		Press the DATA/ENTER key to validate the new setting. "End" is displayed for 1 sec., then the new parameter setting for 0.5 sec.
11		The display returns to the Monitor Display.

■ Setting User Parameters using the LCD Digital Operator

Below in *Table 3.4* the procedure to change C1-01 (Acceleration Time 1) from 10 sec. to 20 sec. is shown using the LCD Digital Operator.

Table 3.4 Setting User Parameters in Advanced Programming Mode using the LCD Digital Operator

Step No.	Digital Operator Display	Description
1	<pre> -DRIVE- Frequency Ref Rdy U1- 01=50.00Hz ----- U1-02= 0.00Hz U1-03= 0.00A </pre>	Display after power supply has been turned ON.
2	<pre> -DRIVE- ** Main Menu ** ----- Operation </pre>	Press the MENU key to enter the mode selection display.
3	<pre> -QUICK- ** Main Menu ** ----- Quick Setting </pre>	Press the MENU key to scroll to the position of the advanced programming Menu.
4	<pre> -ADV- ** Main Menu ** ----- Programming </pre>	
5	<pre> -ADV- Initialization A1-01= 0 Select Language </pre>	Press the DATA/ENTER key to access the monitor display.
6	<pre> -ADV- Accel/Decel C1-01= 10.0sec Accel Time 1 </pre>	Press the Increment or Decrement key until C1-01 (Acceleration Time 1) is displayed.
7	<pre> -ADV- Accel/Decel C1-01= 0010.0sec (0,0-6000,0) "10.0sec" </pre>	Press the DATA/ENTER key to access setting display. The setting can be changed now.
8	<pre> -ADV- Accel/Decel C1-01= 0010.0sec (0,0-6000,0) "10.0sec" </pre>	Press the Shift/RESET key to move the flashing digit to the right.
9	<pre> -ADV- Accel/Decel C1-01= 0010.0sec (0,0-6000,0) "10.0sec" </pre>	Press the Decrement key to change the value to 20.00 s.
10	<pre> -ADV- Accel/Decel C1-01= 0020.0sec (0,0-6000,0) "10.0sec" </pre>	Press the DATA/ENTER key to validate the new setting.
11	<pre> -ADV- Entry Accepted </pre>  <pre> -ADV- Accel/Decel C1-01= 20.0sec (0,0-6000,0) "10.0sec" </pre>	"Entry Accepted" is displayed for appr. 1.0 sec. after the data setting has been confirmed with the DATA/ENTER key. The display returns to the C1-01 monitor display.

◆ Verify Mode

Verify mode is used to display any parameters that have been changed from their default settings, either by programming or autotuning. If no parameter setting has been changed the display will show “NONE” with the LED operator or “None Modified” with the LCD operator.

In Verify Mode the same procedures as in the programming modes can be used to change parameter settings.

■ Example Operations with LED Digital Operator

Fig 3.12 shows an example of operations in the Verify Mode. In that example following parameters have been changed from their default settings: Reference Selection (b1-01), Acceleration Time 1 (c1-01), Input Voltage Setting (E1-01) and Motor Rated Current (E2-01).

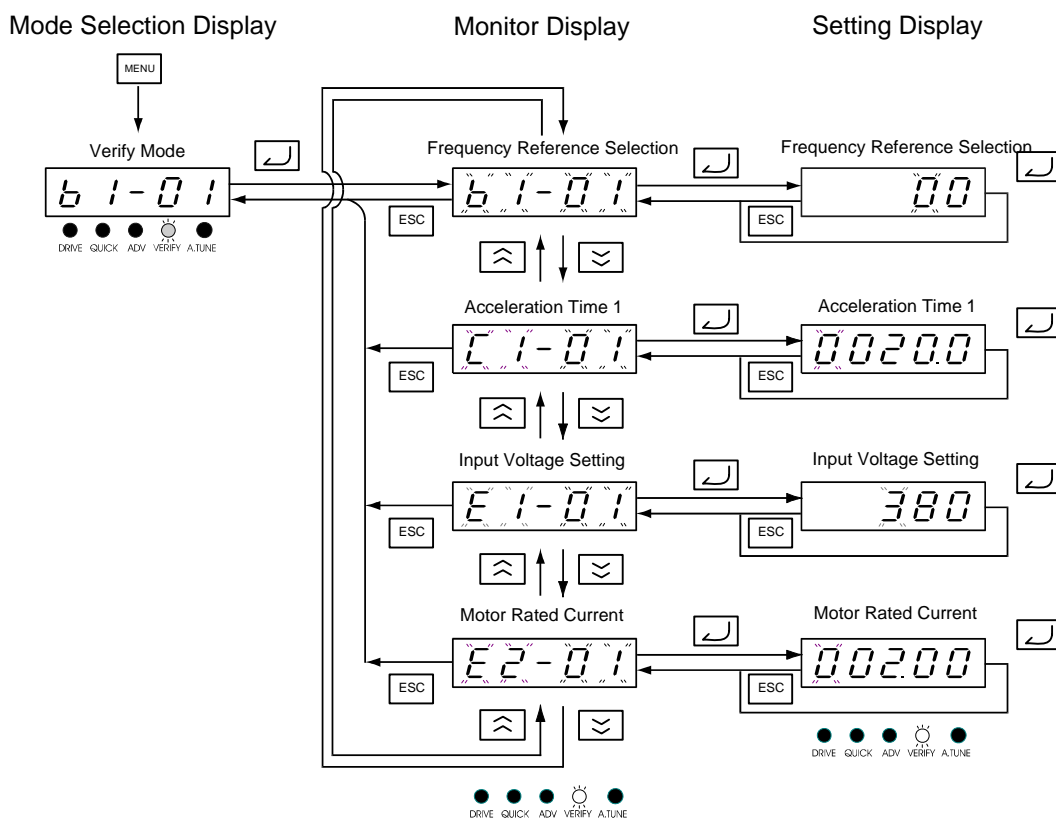

Fig 3.12 Operations in Verify Mode with LED Digital Operator

Example Operations with LCD Digital Operator

Fig 3.13 shows an example of operations in the Verify Mode using the LCD Digital Operator. The same parameters have been modified like in Fig 3.12

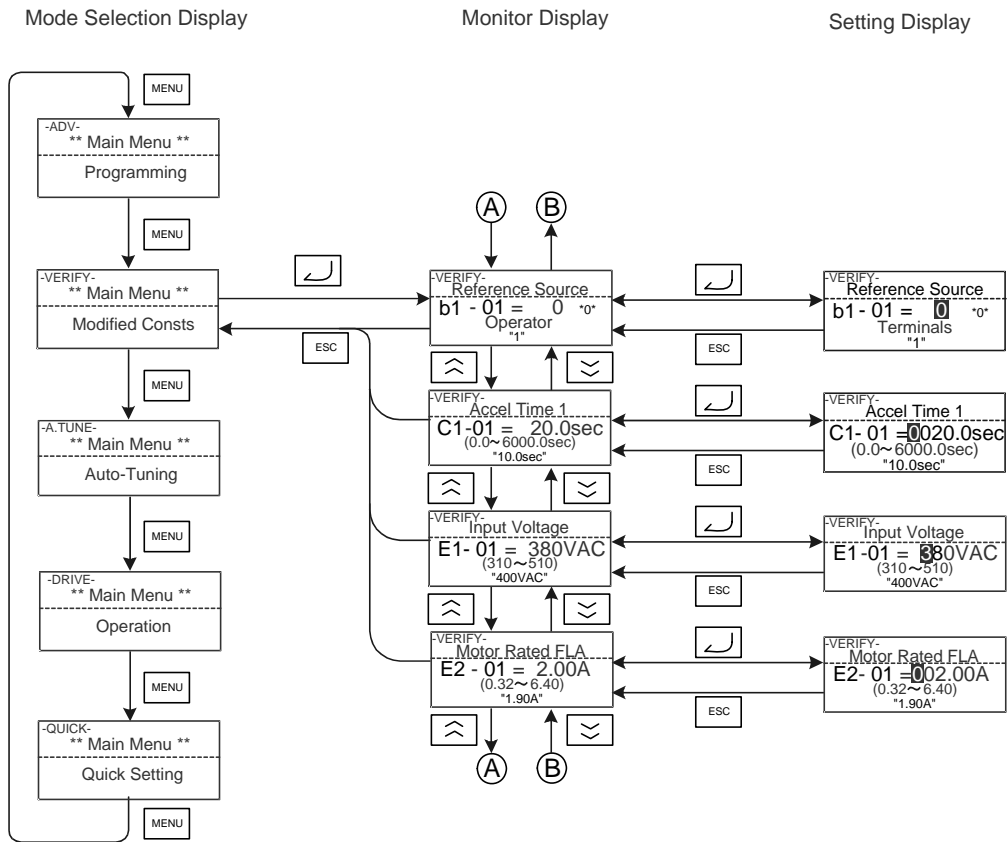

Fig 3.13 Operations in Verify Mode with LCD Digital Operator

◆ Autotuning Mode

Autotuning automatically measures and sets the motor line-to-line resistance parameter including the motor cable in order to compensate the voltage drop and to achieve the best performance.

■ Example Operations with LED Digital Operator

Set the motor rated output power (in kW) and the motor rated current, specified on the motor nameplate and then press the RUN key. The motor is automatically run and the line-to-line resistance is measured.

Fig 3.14 shows an example for an Autotuning procedure.

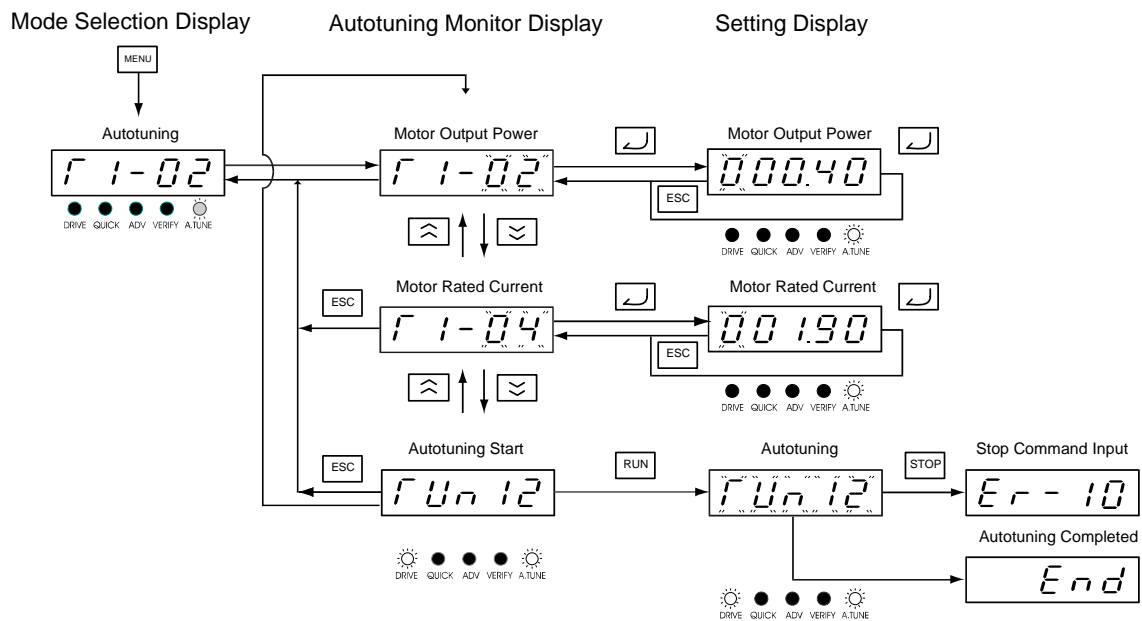

Fig 3.14 Operation in Autotuning Mode with LED Digital Operator

■ Example Operations with LCD Digital Operator

Fig 3.15 shows an example for an Autotuning procedure with LCD Digital Operator

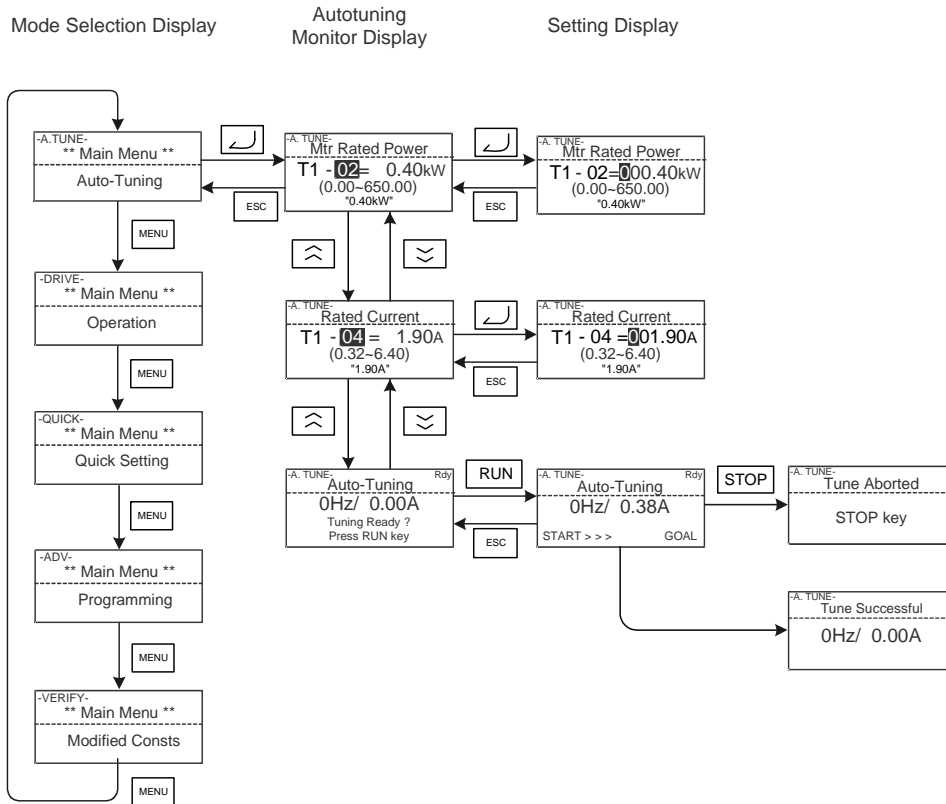

Fig 3.15 Operation in Autotuning Mode with LCD Digital Operator



If a fault occurs during autotuning, refer to [Chapter 7, Troubleshooting](#).



4

Trial Operation

This chapter describes the procedures for trial operation of the Inverter and provides an example of trial operation.

Trial Operation Procedure.....	4-2
Trial Operation	4-3
Adjustment Suggestions	4-11

Trial Operation Procedure

Perform trial operation according to the following flowchart.

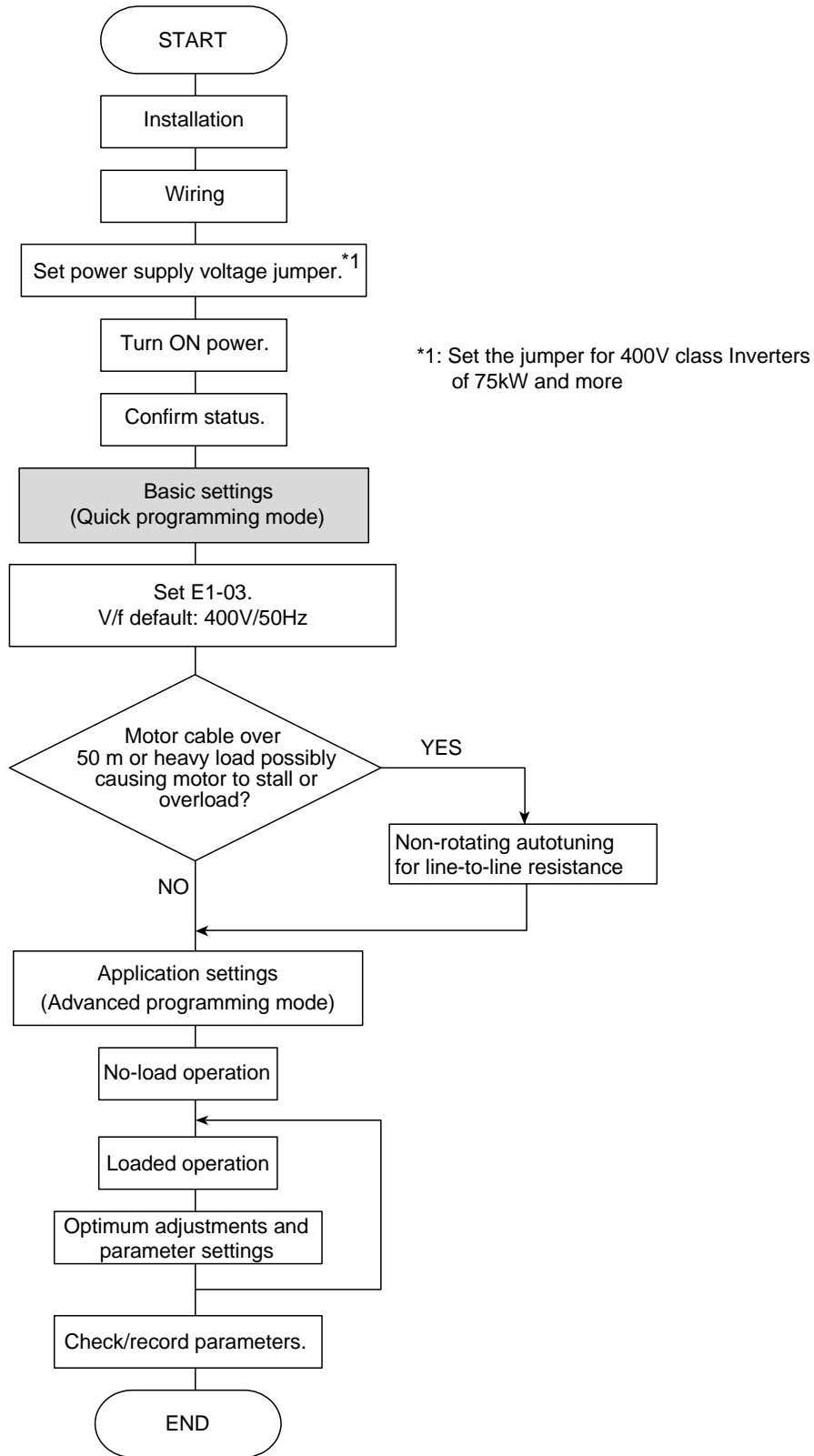

Fig 4.1 Trial Operation Flowchart

Trial Operation

The procedure for the trial operation is described in order in this section.

◆ Application Confirmation

First, confirm the application before using the Inverter. It is designed for:

- Fan, blower, pump

◆ Setting the Power Supply Voltage Jumper (400 V Class Inverters of 75 kW or Higher)

The power supply voltage jumper must be set for 400 V Class Inverters of 75 kW or higher. Insert the jumper into the voltage connector nearest to the actual power supply voltage.

The jumper is factory-set to 440 V when shipped. If the power supply voltage is not 440 V, use the following procedure to change the setting.

1. Turn OFF the power supply and wait for at least 5 minutes.
2. Confirm that the CHARGE indicator has gone out.
3. Remove the terminal cover.
4. Insert the jumper at the position for the voltage supplied to the Inverter (see [Fig 4.2](#)).
5. Return the terminal cover to its original position.

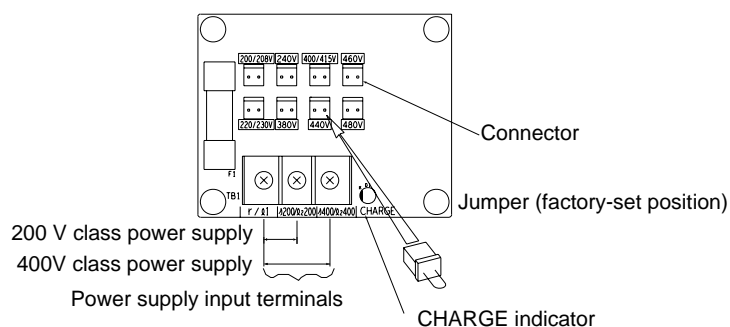

Fig 4.2 Power Supply Voltage Setting

◆ Power ON

Confirm all of the following items and then turn ON the power supply.

- Check that the power supply is of the correct voltage.
 - 200 V class: 3-phase 200 to 240 VDC, 50/60 Hz
 - 400 V class: 3-phase 380 to 480 VDC, 50/60 Hz
- Make sure that the motor output terminals (U, V, W) and the motor are connected correctly.
- Make sure that the Inverter control circuit terminal and the control device are wired correctly.
- Set all Inverter control circuit terminals to OFF.
- Make sure that the motor is not connected to the mechanical system (no-load status) if possible.

◆ Checking the Display Status

After normal power up without any faults the operator display will show the following depending on the operator.

■ Display with LED Digital Operator

After normal power up without any faults the operator display will show the following:

Display for normal operation

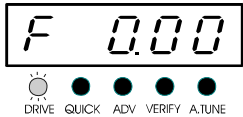

The frequency reference monitor is displayed in the data display section.

When a fault has occurred, the details of the fault will be displayed instead of the above display. In that case, refer to [Chapter 7, Troubleshooting](#). The following display is an example of a display for faulty operation.

Display for fault operation

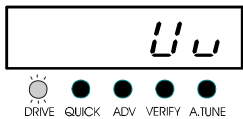

The display will differ depending on the type of fault.
A low voltage alarm is shown at left.

■ Display with LCD Digital Operator

After normal power up without any faults the operator display will show the following:

Display for normal operation

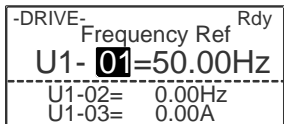

The frequency reference monitor is displayed in the data display section.

When a fault has occurred, the details of the fault will be displayed instead of the above display. In that case, refer to [Chapter 7, Troubleshooting](#). The following display is an example of a display for faulty operation.

Display for fault operation

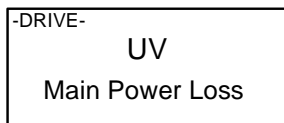

The display will differ depending on the type of fault.
A low voltage alarm is shown at left.

◆ Basic Settings

Before starting the Inverter ensure that it is initialized, i.e. all parameters are set to their factory defaults. Therefor set parameter A1-03 to 2220 for 2-wire initialization or to 3330 for 3-wire initialization. Refer to [page 6-9, Run Command](#) for details about 2-wire and 3-wire initialization.

Refer to [Chapter 3, Digital Operator and Modes](#) for Digital Operator operating procedures. Find a list of the Quick Programming Parameters on [page 5-4, User Parameters Available in Quick Programming Mode](#) and details of the parameters in [Chapter 6, Parameter Settings by Function](#).

Table 4.1 Basic Parameter Settings

●: Must be set. ○: Set as required.

Class	Parameter Number	Name	Description	Setting Range	Factory Setting	Page
●	b1-01	Reference selection	Sets the frequency reference input method. 0: Digital Operator 1: Control circuit terminal (analog input) 2: MEMOBUS communications 3: Option Card	0 to 3	1	6-5 6-52
●	b1-02	Operation method selection	Sets the run command input method. 0: Digital Operator 1: Control circuit terminal (digital input) 2: MEMOBUS communications 3: Option Card	0 to 3	1	6-9 6-52
○	b1-03	Stopping method selection	Selects stopping method when stop command is sent. 0: Deceleration to stop 1: Coast to stop 2: DC braking stop 3: Coast to stop with timer	0 to 3	0	6-11
●	C1-01	Acceleration time 1	Sets the acceleration time in seconds for the output frequency to climb from 0% to 100%.	0.0 to 6000.0	10.0 s	4-11 6-15
●	C1-02	Deceleration time 1	Sets the deceleration time in seconds for the output frequency to fall from 100% to 0%.	0.0 to 6000.0	10.0 s	4-11 6-15
○	d1-01 to d1-04 and d1-17	Frequency references 1 to 4 and jog frequency reference	Sets the required speed references for multi-step speed operation or jogging.	0 to 200.00 Hz	d1-01 to d1-04: 0.00 Hz d1-17: 6.00 Hz	6-7
●	E1-01	Input voltage setting	Sets the Inverter's nominal input voltage in volts.	155 to 255 V*1	200 V*1	6-19 6-100
●	E2-01	Motor rated current	Sets the motor rated current.	0.32 to 6.40 *2	1.90 A *3	6-33 6-99
●	L1-01	Motor protection selection	Used to enable or disable the motor overload protection function. 0: Disabled 1: Protection for general purpose motor (fan cooled) 2: Protection for inverter motor (externally cooled motor) 3: Vector motor protection	0 to 3	1	6-33

Table 4.1 Basic Parameter Settings

●: Must be set. ○: Set as required.

Class	Parameter Number	Name	Description	Setting Range	Factory Setting	Page
○	L3-02	Stall prevention selection during acceleration	Sets the stall prevention level (current limit) during acceleration as a percentage of the Inverter rated current.	0 to 200%	120%	6-17
○	L3-04	Stall prevention selection during deceleration	If using the dynamic brake option (Braking Resistor Units and Braking Units), be sure to set parameter L3-04 to 0 (disabled).	0 to 2	1	6-19

*1. Values for 200 V class Inverters are shown. For a 400 V class Inverter the values have to be doubled.

*2. The setting range is 10% to 200% of the Inverter rated output current. The value for a 200 V class Inverter of 0.4 kW is given.

*3. The factory setting depends on the Inverter capacity. The value for a 200 V class Inverter of 0.4 kW is given

◆ Selecting the V/f pattern

- Set either one of the fixed patterns (0 to E) in E1-03 (V/f Pattern Selection) or set F in E1-03 to specify a user-set pattern as required for the motor and load characteristics in E1-04 to E1-13 in advanced programming mode.

Table 4.1 Selecting the V/f Pattern

Motor	V/f Selection
General purpose motor at 50 Hz	E1-03 = 0
	E1-03 = F (default)(Parameters E1-04 to E-13 are changeable and preset for 50 Hz)
General pupoase motor at 60 Hz	E1-03 = 1

- It is recommended to perform non-rotating autotuning for the line-to-line resistance if the motor cable is 50 m or longer for the actual installation or the load is heavy enough to produce stalling.

◆ Autotuning

■ Autotuning for Line-to-Line Resistance

Autotuning can be used to improve the performance when very long motor cables are used or when motor and inverter have different power ratings.

To perform autotuning set T1-02 (Motor rated power) and T1-04 (Motor rated current) and then press the RUN key on the Digital Operator. The Inverter will supply power to the motor for approximately 20 seconds and the line-to-line resistance (stator windings and cable resistance) will be measured automatically.



Power will be supplied to the motor during autotuning but the motor will not turn. Do not touch the motor until autotuning has been completed.

■ Parameter Settings for Autotuning



The following parameters must be set for autotuning.

Parameter Number	Name	Display	Setting Range	Factory Setting
T1-02	Motor output power	Set the output power of the motor in Kilowatts.	10% to 200% of Inverter rated output	Same as Inverter rated output
T1-04	Motor rated current	Set the rated current of the motor in Amps.	10% to 200% of Inverter rated current	Same as general-purpose motor with same capacity as Inverter

■ Digital Operator Displays during Autotuning using LED Digital Operator

The following displays will appear on the LED Digital Operator during autotuning.

Table 4.2 LED Digital Operator Displays during Autotuning

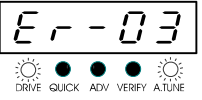
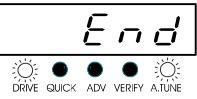
Digital Operator Display	Description
<p>Motor rated power and current: T1-02 and T1-04</p> 	When the Autotuning Mode is entered parameters T1-02 and T1-04 have to entered.
<p>Autotuning start display: TUn12</p> 	The autotuning start display will appear when the parameter settings have been completed. The A.TUNE and DRIVE indicators will be lit. Autotuning will start when the RUN Key is pressed from the autotuning start display.
<p>Autotuning in progress</p>  <p>Stop command input</p> 	If the STOP Key is pressed or a measurement error occurs during autotuning an error message will be display and autotuning will be stopped. Refer to page 7-13, Autotuning Faults for details.
<p>Autotuning completed</p> 	END will be displayed after approximately 20 seconds, indicating that autotuning has been completed.

■ Digital Operator Displays during Autotuning using LCD Digital Operator

The following displays will appear on the LCD Digital Operator during autotuning.

Table 4.3 LCD Digital Operator Displays during Autotuning

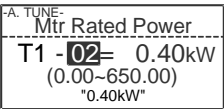
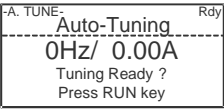
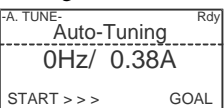
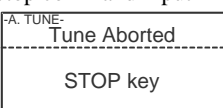
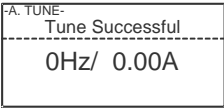
Digital Operator Display	Description
<p>Motor rated power and current: T1-02 and T1-04</p> 	When the Autotuning Mode is entered parameters T1-02 and T1-04 have to entered.
<p>Autotuning start display</p> 	The autotuning start display will appear when the parameter settings have been completed. Autotuning will start when the RUN Key is pressed from the autotuning start display.
<p>Autotuning</p>  <p>Stop command input</p> 	If the STOP Key is pressed or a measurement error occurs during autotuning an error message will be display and autotuning will be stopped. Refer to page 7-13, Autotuning Faults for details.
<p>Autotuning completed</p> 	“Tune Successful” will be displayed after approximately 20 seconds, indicating that autotuning has been completed.

◆ Application Settings

User parameters can be set as required in advanced programming mode. All the parameters that can be set in quick programming mode can also be displayed and set in advanced programming mode.

■ Setting Examples

The following are examples of settings for applications.

- To prevent the machine from being operated in reverse, set b1-04 to 1 to disable reverse operation or to 3 for output phase rotation and reverse disabled.
- To increase the speed of a 50 Hz motor by 10%, set E1-04 to 55.0 Hz.
- To use a 0 to 10 V analog signal for a 50 Hz motor for variable-speed operation between 0 and 45 Hz (0% to 90% speed), set H3-02 to 90.0%.
- To limit the speed range between 20% and 80% set d2-01 to 80.0% and set d2-02 to 20.0%.

◆ No-load Operation

This section describes trial operation in which the motor is in no-load state, that means the machine is not connected to the motor. To avoid failures caused due to the wiring of the control circuit it's recommended to use the LOCAL mode. Press the LOCAL/REMOTE key on the Digital Operator to change to LOCAL mode (the SEQ and REF indicators on the Digital Operator should be OFF).

Always confirm safety around the motor and machine before starting Inverter operation from the Digital Operator. Confirm that the motor works normally and that no errors are displayed at the Inverter. For applications, at which the machine can be driven in one direction only, check the motor rotation direction.

Operation with Jog frequency reference (d1-17, default: 6.00 Hz) can be started and stopped by pressing and releasing the JOG key on the Digital Operator. If the external control circuit prevents operation from the Digital Operator, confirm that emergency stop circuits and machine safety mechanisms are functioning, and then start operation in REMOTE mode (i.e., with a signal from the control signal terminal).



NOTE

Both, a RUN command (forward or reverse) and a frequency reference (or multi-step speed command) must be provided to start Inverter operation.

◆ Loaded Operation

■ Connecting the Load

- After confirming that the motor has stopped completely, connect the mechanical system.
- Be sure to tighten all the screws when connecting the motor shaft to the mechanical system.

■ Operation using the Digital Operator

- Use the Digital Operator to start operation in LOCAL mode in the same way as in no-load operation.
- For the case that a fault occurs during operation, make sure that the STOP key on the Digital Operator is easily accessible.
- At first, set the frequency reference to a low speed, e.g. to one tenth of the nominal operating speed.

■ Checking Operating Status

- Having checked that the operating direction is correct and that the machine is operating smoothly at slow speed, increase the frequency reference.
- After changing the frequency reference or the rotation direction, check that there is no oscillation or abnormal sound from the motor. Check the monitor display to ensure that U1-03 (Output Current) is not too high.
- Refer to [page 4-11, Adjustment Suggestions](#) if hunting, vibration, or other problems originated by the control system occur.

◆ Check and Recording User Parameters

Use verify mode to check user parameters that have been changed for trial operation and record them in a user parameter table.

Any user parameters that have been changed by autotuning will also be displayed in verify mode.

If required, the copy function (parameters o3-01 and o3-02 displayed in advanced programming mode) can be used to copy the changed settings from the inverter to a recording area in the Digital Operator. If changed settings are saved in the Digital Operator, they can be easily copied back to the Inverter to speed up system recovery if the inverter has to be replaced for any reason.

The following functions can also be used to manage user parameters.

- Recording user parameters
- Setting access levels for user parameters
- Setting a password

■ Recording User Parameters (o2-03)

If o2-03 is set to 1 after completing trial operation, the settings of user parameters will be saved in a separate memory area in the inverter. When the Inverter settings have been changed for any reason, the user parameters can be initialized to the settings saved in the separate memory area by setting A1-03 (Initialize) to 1110.

■ User Parameter Access Levels (A1-01)

A1-01 can be set to 0 (monitoring-only) to prevent user parameters from being changed. A1-01 can also be set to 1 (User-specified Parameters) to display only parameters required by the machine or application in a programming mode. These parameters can be determined by setting the A2-□□ parameters.

■ Password (A1-04 and A1-05)

When the access level is set to monitoring-only (A1-01 = 0), a password can be set so that user parameters will be displayed only when the correct password has been input.

Adjustment Suggestions

If hunting, vibration or other problems occur during trial operation, adjust the parameters listed in the following table according to the control method. This table lists the most commonly used user parameters only.

Table 4.4 Useful Parameters in case of Problems during Trial Operation

Name (Parameter Number)	Performance	Factory Setting	Recommended Setting	Adjustment Method
Hunting-prevention gain (N1-02)	Controlling hunting and vibration in middle-range speeds (20 to 80% FMAX)	1.00	0.50 to 2.00	<ul style="list-style-type: none"> Reduce the setting if torque is insufficient for heavy loads. Increase the setting if hunting or vibration occurs for light loads.
Carrier frequency selection (C6-02)	<ul style="list-style-type: none"> Reducing motor magnetic noise Controlling hunting and vibration at low speeds 	Depends on capacity	0.4 kHz to default	<ul style="list-style-type: none"> Increase the setting if motor magnetic noise is high. Reduce the setting if hunting or vibration occurs at low to middle-range speeds.
Torque compensation delay time constant (C4-02)	<ul style="list-style-type: none"> Increasing torque and speed response Controlling hunting and vibration 	Depends on capacity	200 to 1000 ms	<ul style="list-style-type: none"> Reduce the setting if torque or speed response is slow. Increase the setting if hunting or vibration occurs.
Torque compensation gain (C4-01)	<ul style="list-style-type: none"> Improving torque at low speeds (10 Hz or lower) Controlling hunting and vibration 	1.00	0.50 to 1.50	<ul style="list-style-type: none"> Increase the setting in small steps of 0.05 if torque is insufficient at low speeds. Reduce the setting if hunting or vibration occurs for light loads.
Middle output frequency voltage (E1-08) Minimum output frequency voltage (E1-10)	<ul style="list-style-type: none"> Improving torque at low speeds Controlling shock at startup 	Depends on capacity and voltage	Default to "Default + 3 to 5 V"*1	<ul style="list-style-type: none"> Increase the setting in small steps of 1 or 2 V if torque is insufficient at low speeds Reduce the setting if shock at startup is large.

*1. The setting is given for 200 V Class Inverters. Double the voltage for 400 V Class Inverters.

The following user parameters will also affect the control system indirectly.

Table 4.5 Parameters influencing performance indirectly

Name (Parameter Number)	Application
Acceleration/deceleration times (C1-01 to C1-09)	Adjust torque during acceleration and deceleration.
S-curve characteristics (C2-01 and C2-02)	Used to prevent speed shock at start or stop of the acceleration.
Jump frequencies (d3-01 to d3-04)	Used to avoid resonance points during constant speed.
Analog input filter time constant (H3-12)	Used to prevent fluctuations in analog input signals caused by noise.
Stall prevention (L3-01 to L3-06)	Used to prevent OV (overvoltage error) and motor stalling for heavy loads or rapid acceleration/deceleration. Stall prevention is enabled by default and the setting normally has not to be changed. When using an optional braking resistor unit and braking unit, however, disable stall prevention during deceleration by setting L3-04 to 0.





5

User Parameters

This chapter describes all user parameters that can be set in the Inverter.

User Parameter Descriptions	5-2
Digital Operation Display Functions and Levels	5-3
User Parameter Tables	5-6

User Parameter Descriptions

This section describes the contents of the user parameter tables.

◆ Description of User Parameter Tables

User parameter tables are structured as shown below. Here b1-01 (Frequency Reference Selection) is used as an example.

Parameter Number	Name	Description	Setting Range	Factory Setting	Change during Operation	Access Level	MEMOBUS Register	Page
b1-01	Reference selection	Sets the frequency reference input method. 0: Digital Operator 1: Control circuit terminal (analog input) 2: MEMOBUS communications 3: Option Card	0 to 3	1	No	Q	180H	—

- Parameter Number: The number of the user parameter.
- Name: The name of the user parameter.
- Description: Details on the function or settings of the user parameter.
- Setting Range: The setting range for the user parameter.
- Factory Setting: The default setting of the user parameter.
- Change during Operation: Indicates whether the parameter can be changed while the Inverter is in operation or not.
Yes: Changes are possible during operation.
No: Changes are not possible during operation.
- Access Level: Indicates the parameter access level in which the parameter can be changed or monitored.
Q: Quick programming mode and advanced programming mode.
A: Advanced programming mode only.
- MEMOBUS Register: The register number used for MEMOBUS communications.
- Page: Reference page for more detailed information about the parameter.

Digital Operation Display Functions and Levels

The following figure shows the Digital Operator display hierarchy for the Inverter.

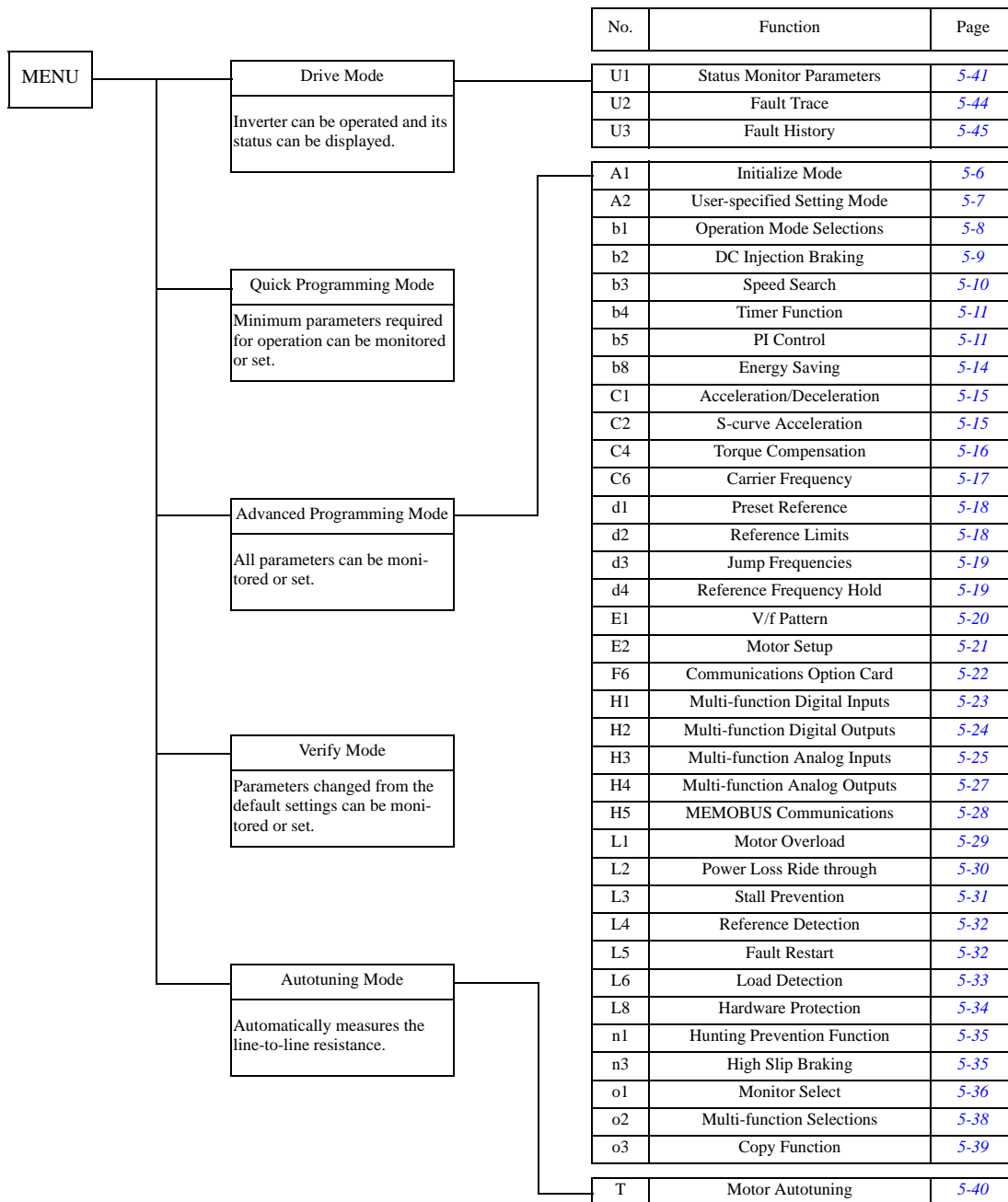

◆ User Parameters Available in Quick Programming Mode

Commonly needed parameters for start-up of the Inverter can be monitored and set in the Quick Programming Mode. Those parameters are listed in the following tables. All user parameters, including the Quick Programming Parameters can be found in the Advanced Programming Mode as well.

■ Quick Programming Parameters that are Always Available

Following table shows the parameter that are always available in Quick Programming Mode.

Parameter Number	Name	Description	Setting Range	Factory Setting	Change during Operation	Access Level	MEMO-BUS Register
b1-01	Reference source selection	Sets the frequency reference input method. 0: Digital Operator 1: Control circuit terminal (analog input) 2: MEMOBUS communications 3: Option Card	0 to 3	1	No	Q	180H
b1-02	RUN command source selection	Sets the run command input method 0: Digital Operator 1: Control circuit terminal (digital multi-function inputs) 2: MEMOBUS communications 3: Option Card	0 to 3	1	No	Q	181H
b1-03	Stopping method selection	Select stopping method when stop command is input. 0: Deceleration to stop 1: Coast to stop 2: DC braking stop (Stops faster than coast to stop, without regenerative operation.) 3: Coast to stop with timer (Run commands are disregarded during deceleration time.)	0 to 3	0	No	Q	182H
b5-01	PI control mode selection	0: Disabled 1: Enabled 3: PI control enabled (frequency reference + PI output) When PI controller is enabled additional parameters are available in Quick Programming Mode and default values are changed, refer to the following table.	0, 1, 3	0	No	A	1A5H
C1-01	Acceleration time 1	Sets the acceleration time to accelerate from 0 Hz to the maximum output frequency.	0.0 to 6000.0	10.0 sec.	Yes	Q	200H
C1-02	Deceleration time 1	Sets the deceleration time to decelerate from the maximum output frequency to 0 Hz.			Yes	Q	201H
d2-01	Frequency reference upper limit	Sets the frequency reference upper limit as a percentage of the max. output frequency.	0.0 to 110.0	100.0%	No	A	289H
d2-02	Frequency reference lower limit	Sets the frequency reference lower limit as a percentage of the maximum output frequency.	0.0 to 110.0	0.0%	No	A	28AH

Parameter Number	Name	Description	Setting Range	Factory Setting	Change during Operation	Access Level	MEMO-BUS Register
E1-01	Input voltage setting	Sets the inverter input voltage. This set value will be the basis for the protection functions.	155 to 255*1	200 V*1	No	Q	300H
E2-01	Motor rated current	Sets the motor rated current in Amps. This set value becomes the base value for motor protection and torque limit. It is an input data for autotuning.	0.32 to 6.40*2	1.90 A*3	No	Q	30EH

*1. These are values for a 200 V class Inverter. For 400 V class Inverters the value has to be doubled.

*2. The setting range is from 10% to 200% of the Inverter rated output current.

*3. The factory setting depends on the Inverter capacity (the value for a 200 V Class Inverter for 0.4 kW is given).

■ Quick Programming Parameters that are Available with Enabled PI Controller

Following list shows the parameters that are available additionally in Quick Programming Mode whenever the PI controller is enabled. The default settings are also set automatically to settings commonly used with the PI controller.

Parameter Number	Name	Description	Setting Range	Factory Setting	Change during Operation	Access Level	MEMO-BUS Register
H3-08	Analog input A2 signal level selection	Selects the signal level input at multi-function analog input A2. 0: 0 to +10V (11 bit input) 2: 4 to 20mA (9 bit input) 3: 0 to 20mA (9 bit input)	0, 2, 3	2	No	Q*1	417H
H3-09	Analog input A2 function selection	Selects the multi-function analog input function for terminal A2. Refer to the table H3-09 Settings for the explanation of the settings range.	0 to 1F	B*2	No	Q*1	418H
H3-13	Terminal A1/A2 switching	Selects on which terminal the main frequency reference can be input. 0: Use analog input 1 on terminal A1 for main frequency reference. 1: Use analog input 2 on terminal A2 for main frequency reference.	0, 1	0	No	Q*1	41CH
b5-31	PI unit selection	Selects the units for the PI controller values (b5-19, U1-24, U1-38). Refer to table b5-31 Settings for the explanation of the setting range	0 to 11	0	No	Q*1	1EDH
b5-02	Proportional (P) gain	Sets the proportional gain of the PI controller. P control is not performed when set to 0.00	0.00 to 25.00	1.00	Yes	Q*1	1A6H
b5-03	Integral (I) time	Sets the integral time of the PI controller. I control is not performed when set to 0.0.	0.0 to 360.0	1.0 sec.	Yes	Q*1	1A7H

*1. Parameter is only moved into Quick Programming Mode when PI controller is enabled, otherwise the parameter is only available in Advanced Programming Mode.

*2. Setting switched to "B" (PI feedback) only when PI controller is enabled, otherwise default setting is "2" (Auxiliary Reference)

User Parameter Tables

◆ Setup Settings: A

■ Initialize Mode: A1

Parameter Number	Name	Description	Setting Range	Factory Setting	Change during Operation	Access Level	MEMO-BUS Register	Page
A1-00	Language selection for Digital Operator display	Used to select the language displayed on the LCD or HOA Digital Operator only. 0: English 2: German 3: French 4: Italian 5: Spanish 6: Portuguese This parameter is not changed by the initialize operation.	0 to 6	0	Yes	A	100H	–
A1-01	Parameter access level	Used to set the parameter access level (set/read.) 0: Monitoring only (Monitoring drive mode and setting A1-01 and A1-04.) 1: Used to select user parameter (Only parameters set in A2-01 to A2-32 can be read and set.) 2: Advanced (Parameters can be read and set in both, quick programming mode (Q) and advanced programming (A) mode.)	0 to 2	2	Yes	A	101H	6-117
A1-03	Initialize	Used to initialize the parameters using the specified method. 0: No initializing 1110: Initializes using the user parameters that have been stored before using o2-03 parameter 2220: Initializes using a two-wire sequence. (Initializes to the factory setting.) 3330: Initializes using a three-wire sequence.	0 to 3330	0	No	A	103H	–
A1-04	Password	Password input when a password has been set in A1-05. This function write-protects parameters of the initialize mode. If the password is changed, A1-01 to A1-03 and A2-01 to A2-32 parameters can only be changed after inputting the right password.	0 to 9999	0	No	A	104H	6-117
A1-05	Password setting	Used to set a four digit number as the password. Usually this parameter is not displayed. When the password (A1-04) is displayed, hold down the RESET key and press the Menu key and A1-05 will be displayed.	0 to 9999	0	No	A	105H	6-117

■ User-set Parameters: A2

Parameter Number	Name	Description	Setting Range	Factory Setting	Change during Operation	Access Level	MEMO-BUS Register	Page
A2-01 to A2-32	User-set parameters	Used to select the function for each of the user specified parameters. User parameters are the only accessible parameters if Parameter Access Level is set to user parameters (A1-01=1)	b1-01 to o3-02	–	No	A	106H to 125H	6-118

◆ Application Parameters: b

■ Operation Mode Selections: b1

Parameter Number	Name	Description	Setting Range	Factory Setting	Change during Operation	Access Level	MEMO-BUS Register	Page
b1-01	Reference source selection	Sets the frequency reference input method. 0: Digital Operator 1: Control circuit terminal (analog inputs) 2: Serial communications (RS 422/485) 3: Option Card (connected on CN2)	0 to 3	1	No	Q	180H	6-5 6-52
b1-02	RUN command source selection	Sets the run command input method. 0: Digital Operator 1: Control circuit terminal (digital multifunction inputs) 2: Serial communications (RS 422/485) 3: Option Card (connected on CN2)	0 to 3	1	No	Q	181H	6-9 6-52
b1-03	Stopping method selection	Selects the stopping method when the Run signal is removed 0: Deceleration to stop 1: Coast to stop 2: DC injection to stop 3: Coast to stop with timer (New Run commands are disregarded while coasting.)	0 to 3	0	No	Q	182H	6-11
b1-04	Prohibition of reverse operation	0: Reverse enabled 1: Reverse disabled 2: Output Phase Rotation (both rotational directions are enabled) 3: Output Phase Rotation with Reverse disabled.	0 to 3	0	No	A	183H	6-37
b1-07	Operation selection after switching to remote mode	Selects if the Inverter accepts a Run command that is already set when the Inverter is switched to Remote Mode. 0: Preset Run signals are disregarded. (Run signal has to be cycled once to become active) 1: Preset Run signals become effective immediately after switching to the Remote mode.	0 or 1	0	No	A	186H	–
b1-08	Run command selection in programming modes	Selects if a Run signal will be accepted when the Inverter is in any Programming Mode. 0: Run signal is disregarded. 1: Run signal is accepted (Disabled for b1-02 = 0).	0 or 1	0	No	A	187H	–

Parameter Number	Name	Description	Setting Range	Factory Setting	Change during Operation	Access Level	MEMO-BUS Register	Page
b1-11	RUN delay	Sets the delay time for the execution of the Run signal. During the delay the Digital Operator display will show "ddLY"	0 to 600	0 sec.	No	A	1DFH	–
b1-12	HAND frequency reference source selection ^{*1}	Sets the source of frequency reference for HAND operation. 0: Digital Operator 1: Control Circuit Terminal (analog input)	0 or 1	0	No	A	1E0H	6-61
b1-13	HAND/AUTO switching during Run selection ^{*1}	Selects if the Inverter will permit switching between HAND and AUTO Modes while running. 0: Disabled 1: Enabled	0 or 1	0	No	A	61DH	6-61
b1-14	Emergency override speed	Sets the frequency reference used in emergency override mode when b1-15=0.	0.00 to 200.0	0.00 Hz	No	A	61AH	6-108
b1-15	Emergency override reference selection	Selects the emergency override reference source. 0: Use b1-14 as frequency reference 1: Use AUTO as frequency reference	0 or 1	0	No	A	61BH	6-108

*1. This parameter is effective only, when the HOA operator JVOP-162 is used.

■DC Injection Braking: b2

Parameter Number	Name	Description	Setting Range	Factory Setting	Change during Operation	Access Level	MEMO-BUS Register	Page
b2-01	DC injection braking start frequency	Used to set the frequency at which DC injection braking starts in units of Hz when b1-03 is set to 0 (deceleration to stop). If b2-01 < E1-09 (Min. output freq.) then DC injection begins at E1-09.	0.0 to 10.0	0.5 Hz	No	A	189H	6-13
b2-02	DC injection braking current	Sets the DC injection braking current as a percentage of the Inverter rated current.	0 to 100	50%	No	A	18AH	6-11 6-13
b2-03	DC injection braking time at start	Sets the time DC injection braking is performed before the Inverter starts to accelerate the motor. Used to stop a coasting motor before restarting it. A set value of 0 sec. disables DC injection braking at start.	0.00 to 10.00	0.00 sec.	No	A	18BH	6-13
b2-04	DC injection braking time at stop	Sets the time DC injection braking is performed after finished deceleration. Used to prevent coasting at the end of deceleration. A set value of 0 sec. disables DC injection braking at stop	0.00 to 10.00	0.50 sec.	No	A	18CH	6-11 6-13

Parameter Number	Name	Description	Setting Range	Factory Setting	Change during Operation	Access Level	MEMO-BUS Register	Page
b2-09	Motor preheat current 1	Sets the motor preheat current level in % of the Inverter rated current. Motor preheat is enabled by a digital input.	0 to 100	0%	No	A	1E1H	6-106
b2-10	Motor preheat current 2	Sets the motor preheat current level 2 in % of the Inverter rated current. Motor preheat 2 is enabled by a digital input.	0 to 10	5%	No	A	61CH	6-106

■ Speed Search: b3

Parameter Number	Name	Description	Setting Range	Factory Setting	Change during Operation	Access Level	MEMO-BUS Register	Page
b3-01	Speed search selection (current detection or speed calculation)	<p>Enables/disables the speed search function and sets the speed search method.</p> <p>0: Disabled, speed calculation 1: Enabled, speed calculation 2: Disabled, current detection 3: Enabled, current detection</p> <p>Speed Calculation: When the search is started, the motor speed is calculated and acceleration/deceleration is performed from the calculated speed to the specified frequency (motor direction is also searched).</p> <p>Current Detection: The speed search is started from the frequency when power was momentarily lost and the maximum frequency, and the speed is detected at the search current level.</p>	0 to 3	2	No	A	191H	6-39
b3-02	Speed search operating current (current detection)	Sets the speed search operation current as a percentage, taking the Inverter rated current as 100%. Usually not necessary to set. When restarting is not possible with the factory settings, reduce the value.	0 to 200	120%	No	A	192H	6-39
b3-03	Speed search deceleration time (current detection)	<p>Sets the output frequency deceleration time during speed search in 1-second units.</p> <p>Sets the time for deceleration from the maximum output frequency to the minimum output frequency.</p>	0.1 to 10.0	2.0 sec.	No	A	193H	6-39
b3-05	Speed search wait time (current detection or speed calculation)	When a speed search is performed after recovering from a momentary power loss, the search operation is delayed for the time set here. If e.g. a contactor is used at the output side of the inverter set this parameter to the contactor delay time or more.	0.0 to 20.0	0.2 sec.	No	A	195H	6-39

Parameter Number	Name	Description	Setting Range	Factory Setting	Change during Operation	Access Level	MEMO-BUS Register	Page
b3-14	Bi-directional speed search selection	Disables or enables the bi-directional capabilities of the speed search function. 0: Disabled 1: Enabled	0 or 1	1	No	A	19EH	6-39

■Timer Function: b4

Parameter Number	Name	Description	Setting Range	Factory Setting	Change during Operation	Access Level	MEMO-BUS Register	Page
b4-01	Timer function ON-delay time	Sets the timer function output ON-delay time (dead time) for the timer function input. Enabled when the timer function is set in H1-□□ and H2-□□.	0.0 to 3000.0	0.0 sec.	No	A	1A3H	6-86
b4-02	Timer function OFF-delay time	Sets the timer function output OFF-delay time (dead band) for the timer function input. Enabled when a timer function is set in H1-□□ and H2-□□	0.0 to 3000.0	0.0 sec.	No	A	1A4H	6-86

■PI Control: b5

Parameter Number	Name	Description	Setting Range	Factory Setting	Change during Operation	Access Level	MEMO-BUS Register	Page
b5-01	PI control mode selection	0: Disabled 1: Enabled 3: PI control enabled (frequency reference + PI output)	0, 1, 3	0	No	Q	1A5H	6-87
b5-02	Proportional (P) gain	Sets the proportional gain of the PI controller. P control is not performed when set 0.00.	0.00 to 25.00	1.00	Yes	A*1	1A6H	6-87
b5-03	Integral (I) time	Sets the integral time of the PI controller. I control is not performed when set to 0.0 sec.	0.0 to 360.0	1.0 sec.	Yes	A*1	1A7H	6-87
b5-04	Integral (I) limit	Sets the I control limit as a percentage of the maximum output frequency.	0.0 to 100.0	100.0%	Yes	A	1A8H	6-87
b5-06	PI limit	Sets the limit after PI control as a percentage of the maximum output frequency.	0.0 to 100.0	100.0%	Yes	A	1AAH	6-87
b5-07	PI offset	Sets the offset after PI control as a percentage of the maximum output frequency.	-100.0 to +100.0	0.0%	Yes	A	1ABH	6-87
b5-08	PI delay time constant	Sets the time constant for low pass filter of the PI control output. Usually not necessary to set.	0.00 to 10.00	0.00 sec.	Yes	A	1ACH	6-87
b5-09	PI output characteristics selection	Selects forward/reverse direction for PI output. 0: PI output is forward. 1: PI output is reversed.	0 or 1	0	No	A	1ADH	6-87
b5-10	PI output gain	Sets output gain.	0.0 to 25.0	1.0	No	A	1AEH	6-87

Parameter Number	Name	Description	Setting Range	Factory Setting	Change during Operation	Access Level	MEMO-BUS Register	Page
b5-11	PI reverse output selection	0: Limit to 0 when PI output is negative. 1: Reverses when PI output is negative. Limit to 0 is also active when reverse operation disabled is selected by b1-04.	0 or 1	0	No	A	1AFH	6-87
b5-12	Selection of PI feedback signal loss detection	0: No detection of PI feedback loss. 1: Detection of PI feedback loss. Operation continues during detection, the fault relay is not operated. 2: Detection of PI feedback loss. The motor coasts to stop at detection, and the fault relay operates.	0 to 2	0	No	A	1B0H	6-87
b5-13	PI feedback loss detection level	Sets the PI feedback loss detection level as percentage using the maximum output frequency as 100%.	0 to 100	0%	No	A	1B1H	6-87
b5-14	PI feedback loss detection time	Sets the PI feedback loss detection time.	0.0 to 25.5	1.0 sec.	No	A	1B2H	6-87
b5-15	Sleep function operation level	Sets the sleep function start level as a frequency.	0.0 to 200.0	0.0 Hz	No	A	1B3H	6-87
b5-16	Sleep operation delay time	Sets the delay time until the sleep function starts.	0.0 to 25.5	0.0 sec.	No	A	1B4H	6-87
b5-17	Accel/decel time for PI reference	Sets the accel/decel time for the PI Softstarter (SFS).	0.0 to 25.5	0.0 sec.	No	A	1B5H	6-87
b5-18	PI Setpoint Selection	0: Disabled 1: Enabled	0 to 1	0	No	A	1DCH	6-87
b5-19	PI Setpoint	PI target value	0.00 to 100.00 %	0	Yes	A	1DDH	6-87
b5-20	PI Setpoint Scaling	Sets the unit for b5-19, U1-38 and U1-24 0: 0.01 Hz 1: 0.01% (the maximum output frequency E1-04 is taken as 100%). 2 – 39: rpm, set value is equal to motor poles 40 – 39999: User desired display □□□□□ ↑ Sets the display value for 100 %. ↑ Sets the number of decimal digits.	0 to 39999	1	No	A	1E2H	6-87
b5-21	Sleep Function Selection	Sets the operation method of the PI sleep function 0: PI Setpoint 1: SFS Input 2: Snooze	0 to 2	1	No	A	1E3H	6-87

Parameter Number	Name	Description	Setting Range	Factory Setting	Change during Operation	Access Level	MEMO-BUS Register	Page
b5-22	Snooze Level	Sets the frequency level at which the snooze operation starts as percentage of the max. output frequency.	0 to 100	0%	Yes	A	1E4H	6-87
b5-23	Snooze Delay Time	Sets a delay timer for the snooze function	0 to 3600	0 sec.	No	A	1E5H	6-87
b5-24	Wake-Up Level	Sets the feedback level at which the inverter wakes up from snooze operation.	0 to 100	0%	No	A	1E6H	6-87
b5-25	Setpoint Boost	Sets the PI setpoint boost when the snooze mode is activated. If it is reached once the output will be switched off. The value is set as percentage of the PI setpoint.	0 to 100	0%	No	A	1E7H	6-87
b5-26	Maximum Boost Time	Sets the maximum time the boost operation is performed.	0 to 3600	0 sec.	No	A	1E8H	6-87
b5-27	Snooze feedback	PI Snooze function will only be activated when the feedback value is above this parameter setting. The value is set as percentage of the PI setpoint.	0 to 100	60%	No	A	1E9H	6-87
b5-28	PI Feedback Square Root Operation	Enables or disables the square root operation for the PI feedback value. 0: Disabled 1: Enabled	0 or 1	0	No	A	1EAH	6-87
b5-29	PI Feedback Square Root Gain	Sets the gain for the feedback when square root operation is enabled.	0 to 2.00	1.00	No	A	1EBH	6-87
b5-30	PI Output Monitor Square Root	Selects whether the PI output monitor is shown as square root value or not. 0: Disable 1: Enable	0 or 1	0	No	A	1ECH	6-87
b5-31	PI unit selection ^{*2}	Selects the units for the PI controller values (b5-19, U1-24, U1-38). Refer to table b5-31 Settings for the explanation of the setting range.	0 to 11	0	No	A ^{*1}	1EDH	6-87

*1. Parameter is moved into Quick Programming Mode when PI controller is enabled, otherwise the parameter is available only in Advanced Programming Mode.

*2. Parameter function is only valid if a Digital Operator with LCD clear text display is used (LCD or HOA Digital Operator)

b5-31 Settings

Setting Value	Function	Displayed Unit
0	WC: Inch of water column	WC
1	PSI: lb/square inch	PSI
2	GPM: Gallons per minute	GPM
3	F: Degree Fahrenheit	F
4	CFM: Cubic feet per minute	CFM
5	CMH: Cubic meter per hour	CMH
6	LPH: Liters per hour	LPH
7	LPS: Liters per second	LPS

Setting Value	Function	Displayed Unit
8	Bar: Bar	Bar
9	Pa: Pascal	Pa
10	C: Degree Celsius	C
11	Mtr: Meters	Mtr

■Energy Saving: b8

Parameter Number	Name	Description	Setting Range	Factory Setting	Change during Operation	Access Level	MEMO-BUS Register	Page
b8-01	Energy-saving mode selection	Enables or disables the energy-saving function. 0: Disable 1: Enable	0 or 1	0	No	A	1CCH	6-98
b8-04	Energy-saving coefficient	Sets the energy-saving coefficient. Adjust the value in 5% steps until the output power becomes minimal.	0.0 to 655.00	*1	No	A	1CFH	6-98
b8-05	Power detection filter time constant	Sets the time constant for output power detection.	0 to 2000	20msec	No	A	1D0H	6-98
b8-06	Search operation voltage limiter	Sets the limit value of the voltage control range during search operation. Set to 0 to disable the search operation. 100% is the motor rated voltage.	0 to 100	0%	No	A	1D1H	6-98

*1. The factory setting depends on the Inverter capacity.

◆ Tuning Parameters: C

■ Acceleration/Deceleration: C1

Parameter Number	Name	Description	Setting Range	Factory Setting	Change during Operation	Access Level	MEMO-BUS Register	Page
C1-01	Acceleration time 1	Sets the acceleration time to accelerate from 0 Hz to the maximum output frequency.	0.0 to 6000.0	10.0 sec.	Yes	Q	200H	4-11 6-15
C1-02	Deceleration time 1	Sets the deceleration time to decelerate from the maximum output frequency to 0 Hz.			Yes	Q	201H	4-11 6-15
C1-03	Acceleration time 2	Sets the acceleration time when the multi-function input "accel/decel time 1" is set to ON.			Yes	A	202H	6-15
C1-04	Deceleration time 2	Sets the deceleration time when the multi-function input "accel/decel time 1" is set to ON.			Yes	A	203H	6-15
C1-09	Emergency stop time	Sets the deceleration time when the multi-function input "Emergency (fast) Stop" is set to ON.			No	A	208H	6-15
C1-11	Accel/decel time switching frequency	Sets the frequency for automatic acceleration/deceleration switching. If the output frequency is below the set frequency: Accel/decel time 2 If the output frequency is above the set frequency: Accel/decel time 1 The multi-function input "accel/decel time 1" has priority.	0.0 to 200.0	0.0 Hz	No	A	20AH	6-15

■ S-Curve Acceleration/Deceleration: C2

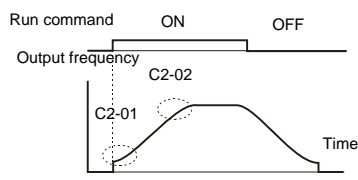
Parameter Number	Name	Description	Setting Range	Factory Setting	Change during Operation	Access Level	MEMO-BUS Register	Page
C2-01	S-curve characteristic time at acceleration start	When the S-curve characteristic time is set, the accel time will increase by only half of the S-curve characteristic times at start and end. 	0.00 to 2.50	0.20 sec.	No	A	20BH	6-16
C2-02	S-curve characteristic time at acceleration end	$T_{\text{accel}} = \frac{C2-01}{2} + C1-01 + \frac{C2-02}{2}$ The S-Curve characteristic times at start and end of deceleration are fixed to 0.2 sec. and can not be changed.		0.20 sec.	No	A	20CH	6-16

■ Torque Compensation: C4

Parameter Number	Name	Description	Setting Range	Factory Setting	Change during Operation	Access Level	MEMO-BUS Register	Page
C4-01	Torque compensation gain	<p>Sets the torque compensation gain. Usually setting is not necessary. Adjust under the following circumstances:</p> <ul style="list-style-type: none"> • When the motor cable is long increase the set value. • When the motor capacity is smaller than the Inverter capacity (Max. applicable motor capacity), increase the set values. • When the motor speed is oscillating, decrease the set values. <p>Adjust the torque compensation gain so that at minimum speed the output current does not exceed the Inverter rated output current.</p>	0.00 to 2.50	1.00	Yes	A	215H	4-11 6-27
C4-02	Torque compensation delay time constant	<p>The torque compensation delay time is set in ms units. Usually setting is not necessary. Adjust under the following circumstances:</p> <ul style="list-style-type: none"> • When the motor is oscillating, increase the set values. • When the responsiveness of the motor is low, decrease the set values. 	0 to 10000	200 ms	No	A	216H	4-11 6-27

■ Carrier Frequency: C6

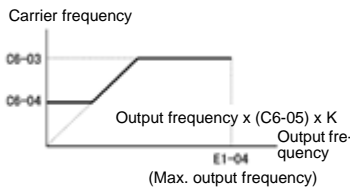
Parameter Number	Name	Description	Setting Range	Factory Setting	Change during Operation	Access Level	MEMO-BUS Register	Page
C6-01	Normal duty selection	1: Normal Duty 1 2: Normal Duty 2	1 or 2	1	No	A	223H	6-2
C6-02	Carrier frequency selection	Selects the carrier frequency. Select F to enable detailed settings using parameters C6-03 to C6-05.	0 to F	6 *1	No	A	224H	4-11 6-2
C6-03	Carrier frequency upper limit	Sets the carrier frequency upper limit and lower limit in kHz units. The carrier frequency gain is set as follows:	2.0 to 15.0 *2 *3	15.0 kHz *1	No	A	225H	6-2
C6-04	Carrier frequency lower limit	 <p>K is a coefficient that depends on the setting of C6-03. C6-03 ≥ 10.0 kHz: K = 3 10.0 kHz > C6-03 ≥ 5.0 kHz: K = 2 5.0 kHz > C6-03: K = 1</p>	0.4 to 15.0 *2 *3	15.0 kHz *1	No	A	226H	6-2
C6-05	Carrier frequency proportional gain	K is a coefficient that depends on the setting of C6-03. C6-03 ≥ 10.0 kHz: K = 3 10.0 kHz > C6-03 ≥ 5.0 kHz: K = 2 5.0 kHz > C6-03: K = 1	00 to 99 *3	00	No	A	227H	6-2

*1. The factory setting depends on the Inverter capacity and the protection class.

*2. The setting range depends on the Inverter capacity.

*3. This parameter can only be set when C6-02 is set to F.

◆ Reference Parameters: d

■ Preset Reference: d1

Parameter Number	Name	Description	Setting Range	Factory Setting	Change during Operation	Access Level	MEMO-BUS Register	Page
d1-01	Frequency reference 1	Sets the frequency reference.	0 to FMAX	0.00 Hz	Yes	A	280H	6-7
d1-02	Frequency reference 2	Sets the frequency reference when multi-step speed command 1 is ON for a multi-function input.		0.00 Hz	Yes	A	281H	6-7
d1-03	Frequency reference 3	Sets the frequency reference when multi-step speed command 2 is ON for a multi-function input.		0.00 Hz	Yes	A	282H	6-7
d1-04	Frequency reference 4	Sets the frequency reference when multi-step speed commands 1 and 2 are ON for multi-function inputs.		0.00 Hz	Yes	A	283H	6-7
d1-17	Jog frequency reference	Sets the frequency reference when the jog frequency reference selection, FJOG command, or RJOG command is ON.		6.00 Hz	Yes	A	292H	6-7 6-62

Note: The unit is set in o1-03 (frequency units of reference setting and monitor, default: 0.01 Hz).

■ Reference Limits: d2

Parameter Number	Name	Description	Setting Range	Factory Setting	Change during Operation	Access Level	MEMO-BUS Register	Page
d2-01	Frequency reference upper limit	Sets the frequency reference upper limit as a percentage of the max. output frequency.	0.0 to 110.0	100.0%	No	Q	289H	6-24 6-55
d2-02	Frequency reference lower limit	Sets the frequency reference lower limit as a percentage of the maximum output frequency.	0.0 to 110.0	0.0%	No	Q	28AH	6-24 6-55
d2-03	Master speed reference lower limit	Sets the master speed reference lower limit as a percentage of the max. output frequency.	0.0 to 110.0	0.0%	No	A	293H	6-24 6-55

Note: The PI Sleep Function is also available and can be used without enabled PI controller. It can be used to let the inverter switch off automatically when a minimum output frequency (set in b5-15) has been output for a time longer than b5-16. Refer also to [page 6-94, PI Sleep Function](#).

■ Jump Frequencies: d3

Parameter Number	Name	Description	Setting Range	Factory Setting	Change during Operation	Access Level	MEMO-BUS Register	Page
d3-01	Jump frequency 1	Sets the jump (resonance) frequencies in Hz. The function is disabled when the jump frequency is set to 0 Hz.	0.0 to 200.0	0.0 Hz	No	A	294H	6-23
d3-02	Jump frequency 2	Always ensure the following setting order: $d3-01 \geq d3-02 \geq d3-03$		0.0 Hz	No	A	295H	6-23
d3-03	Jump frequency 3	Operation in the jump frequency range is prohibited but during acceleration and deceleration, the speed changes smoothly without jumping over the set frequencies		0.0 Hz	No	A	296H	6-23
d3-04	Jump frequency width	Sets the jump frequency bandwidth in Hz. The jump frequency range will be the jump frequency \pm d3-04.	0.0 to 20.0	1.0 Hz	No	A	297H	6-23

■ Reference Frequency Hold: d4

Parameter Number	Name	Description	Setting Range	Factory Setting	Change during Operation	Access Level	MEMO-BUS Register	Page
d4-01	Frequency reference hold function selection	Sets whether or not frequency reference value on hold will be recorded. 0: Disabled (when operation is stopped or the power is turned on again the frequency reference is set to 0.) 1: Enabled (when operation is stopped or the power is turned on again the inverter starts at the previous hold frequency.) This function is available when the multi-function inputs “Accel/Decel Ramp Hold” or “UP/DOWN” commands are set.	0 or 1	0	No	A	298H	6-54 6-55
d4-02	Trim Control Level	Sets the frequency to be added to or subtracted from the analog frequency reference as a percentage of the max. output frequency. Enabled when the Trim control increase command or Trim control decrease command is set for a multi-function input.	0 to 100	10%	No	A	299H	6-58

◆ Motor Parameters: E

■ V/f Pattern: E1

Parameter Number	Name	Description	Setting Range	Factory Setting	Change during Operation	Access Level	MEMO-BUS Register	Page
E1-01	Input voltage setting	Sets the Inverter input voltage. This setting is used as a reference value for protection functions.	155 to 255 *1	200 V *1	No	Q	300H	6-100 6-19
E1-03	V/f pattern selection	0 to E: Select from the 15 preset patterns. F: Custom user-set pattern (Applicable for setting of E1-04 to E1-10.) FF: Custom user-set pattern without voltage and frequency limits	0 to F, FF	F	No	A	302H	6-100
E1-04	Max. output frequency (FMAX)	<p>Output Voltage (V)</p> <p>VMAX (E1-05) (VBASE) (E1-13)</p> <p>VB (E1-08)</p> <p>VMIN (E1-10)</p> <p>FMIN (E1-09) FB (E1-07) FA (E1-06) FMAX (E1-04)</p> <p>Frequency (Hz)</p>	0.0 to 200.0	50.0 Hz	No	A	303H	6-100
E1-05	Max. output voltage (VMAX)		0.0 to 255.0 *1	200.0 V *1	No	A	304H	6-100
E1-06	Base frequency (FA)		0.0 to 200.0	50.0 Hz	No	A	305H	6-100
E1-07	Mid. output frequency (FB)		0.0 to 200.0	2.5 Hz	No	A	306H	6-100
E1-08	Mid. output frequency voltage (VB)		0.0 to 255 *1	15.0 V *1	No	A	307H	6-100
E1-09	Min. output frequency (FMIN)	Always ensure that the four frequencies are set in the following manner:	0.0 to 200.0	1.2 Hz	No	A	308H	6-100
E1-10	Min. output frequency voltage (VMIN)	E1-04 (FMAX) ≥ E1-06 (FA) > E1-07 (FB) ≥ E1-09 (FMIN)	0.0 to 255.0 *1	9.0 V *1	No	A	309H	4-11 6-100
E1-11	Mid. output frequency 2	Set only to fine-adjust V/f for the output range. Normally, this setting is not required.	0.0 to 200.0	0.0 Hz *2	No	A	30AH	6-100
E1-12	Mid. output frequency voltage 2		0.0 to 255.0 *1	0.0 V *2	No	A	30BH	6-100
E1-13	Base voltage (VBASE)	Sets the output voltage of the base frequency (E1-06).	0.0 to 255.0 *1	0.0 V	No	A	30CH	6-100

*1. Values for 200 V class Inverters are shown. For a 400 V class Inverter the values have to be doubled.

*2. Parameters E1-11 and E1-12 are disabled when set to 0.0

■ Motor Setup: E2

Parameter Number	Name	Description	Setting Range	Factory Setting	Change during Operation	Access Level	MEMO-BUS Register	Page
E2-01	Motor rated current	Sets the motor rated current. This set value will become the reference value for motor protection and torque limits. This parameter is an input data for autotuning.	0.32 to 6.40 *1	1.90 A *2	No	Q	30EH	6-33 6-99
E2-03	Motor no-load current	Sets the motor no-load current. This parameter is automatically set during autotuning.	0.00 to 1.89 *3	1.2 A *2	No	A	310H	6-99
E2-05	Motor line-to-line resistance	Sets the motor phase-to-phase resistance in Ω units. This parameter is automatically set during autotuning.	0.000 to 65.000	9.842 Ω *2	No	A	312H	6-99

*1. The setting range is 10% to 200% of the Inverter rated output current. The value for a 200 V class Inverter of 0.4 kW is given.

*2. The factory setting depends on the Inverter capacity. The value for a 200 V class Inverter of 0.4 kW is given

*3. The setting range is 0.00 A to (E2-01 - 0.01 A).

◆ Option Parameters: F

■ Communications Option Cards: F6

Parameter Number	Name	Description	Setting Range	Factory Setting	Change during Operation	Access Level	MEMO-BUS Register	Page
F6-01	Operation selection after communications error	Set the stopping method for communications errors. 0: Deceleration to stop using the deceleration time in C1-02 1: Coast to stop 2: Emergency stop using the deceleration time in C1-09 3: Continue operation	0 to 3	1	No	A	3A2H	–
F6-02	Option card external fault detection selection	0: Always detected 1: Detected only during operation	0 or 1	0	No	A	3A3H	–
F6-03	Option card external fault stopping method	0: Deceleration to stop using the deceleration time in C1-02 1: Coast to stop 2: Emergency stop using the deceleration time in C1-09 3: Continue operation	0 to 3	1	No	A	3A4H	–
F6-05	Current scaling via communication option card	Sets the unit of the current monitor 0: Ampere 1: 100% 8192	0 or 1	0	No	A	3A6H	–

◆ Terminal Function Parameters: H

■ Multi-function Digital Inputs: H1

Parameter Number	Name	Description	Setting Range	Factory Setting	Change during Operation	Access Level	MEMO-BUS Register	Page
H1-01	Terminal S3 function selection	Multi-function digital input 1	0 to 82	24	No	A	400H	–
H1-02	Terminal S4 function selection	Multi-function digital input 2	0 to 82	14	No	A	401H	–
H1-03	Terminal S5 function selection	Multi-function digital input 3	0 to 82	3 (0)* ¹	No	A	402H	–
H1-04	Terminal S6 function selection	Multi-function digital input 4	0 to 82	4 (3)* ¹	No	A	403H	–
H1-05	Terminal S7 function selection	Multi-function digital input 5	0 to 82	6 (4)* ¹	No	A	404H	–

*1. The values in parentheses indicate initial values when initialized in 3-wire-sequence.

Multi-function Digital Input Functions

Setting Value	Function	Page
0	3-wire sequence (Forward/Reverse Run command)	6-10
1	Local/Remote selection (ON: Operator, OFF: Parameter b1-01/b1-02 setting)	6-52
2	Operation Source Option Card/Inverter selection (ON: Parameter b1-01/b1-02 setting)	6-60
3	Multi-step speed reference 1 When H3-09 is set to 2, this function is combined with the master/auxiliary speed switch.	6-7
4	Multi-step speed reference 2	6-7
6	Jog frequency command (higher priority than multi-step speed reference)	6-7
7	Acceleration/Deceleration time selection 1	6-15
8	External baseblock NO (NO contact: Baseblock at ON)	6-53
9	External baseblock NC (NC contact: Baseblock at OFF)	6-53
A	Acceleration/deceleration ramp hold (ON: Acceleration/deceleration stopped, frequency is hold)	6-54
C	Multi-function analog input A2 enable (ON: Enable)	6-53
F	Terminal not used	–
10	UP command (Always set with the DOWN command)	6-55
11	DOWN command (Always set with the UP command)	6-55
12	FJOG command (ON: Forward run at jog frequency d1-17)	6-62
13	RJOG command (ON: Reverse run at jog frequency d1-17)	6-62
14	Fault reset (Reset when turned ON)	7-2
15	Emergency stop (NO: Deceleration to stop with deceleration time set in C1-09 when ON.)	6-14
17	Emergency stop (NC: Deceleration to stop with deceleration time set in C1-09 when OFF)	6-14
18	Timer function input (times are set in b4-01 and b4-02 and the timer function outputs are set in H2-□□.)	6-86
19	PI control disable (ON: PI control disabled)	6-87
1B	Parameters write enable (ON: All parameters can be set. OFF: All parameters are write protected.)	6-117
1C	Trim control increase (ON: d4-02 frequency is added to analog frequency reference.)	6-58
1D	Trim control decrease (ON: d4-02 frequency is subtracted from analog frequency reference.)	6-58
1E	Analog frequency reference sample/hold (ON: reference is sampled and hold)	6-59

Setting Value	Function	Page
20 to 2F	External fault Input mode: NO contact/NC contact, detection mode: normal/during operation	6-63
30	PI control integral reset (ON: integral reset and hold as long as input is ON)	6-87
31	PI control integral hold (ON: integral is hold)	6-87
34	PI soft starter disable (ON: disabled)	6-87
35	PI input characteristics switch	6-87
36	Operation Source Option/Inverter selection 2 (ON: option card)	6-60
60	Motor preheat command 1 (ON: Performs motor preheat)	6-106
61	External speed search command 1 (ON: Speed search from maximum output frequency)	6-39
62	External speed search command 2 (ON: Speed search from set frequency)	6-39
64	External speed search command 3	6-39
67	Communications test mode	6-85
68	High Slip braking (HSB)	6-109
69	Jog Frequency 2	6-7
6A	Drive enable (ON: Drive enabled)	6-54
6B	Operation Source Communication/Inverter selection (ON: RS-422/485 port)	6-60
6C	Operation Source Communication/Inverter selection 2 (ON: inverter settings)	6-60
6D*	AUTO mode selection (ON: AUTO mode active)	6-61
6E*	HAND mode selection (ON: HAND mode active)	6-61
70	Bypass Drive Enable (ON: Inverter enabled)	6-54
80	Motor Preheat 2 (ON: motor performs preheat 2)	6-106
81	Emergency Override Forward (ON: Inverter performs emergency override in forward direction)	6-108
82	Emergency Override Reverse (ON: Inverter performs emergency override in reverse direction)	6-108

* This setting is effective only, if the HOA operator JVOP-162 is used.

■ Multi-function Digital Outputs: H2

Parameter Number	Name	Description	Setting Range	Factory Setting	Change during Operation	Access Level	MEMO-BUS Register	Page
H2-01	Terminal M1-M2 function selection	Multi-function digital output 1	0 to 3D	0	No	A	40BH	–
H2-02	Terminal M3-M4 function selection	Multi-function digital output 2	0 to 3D	1	No	A	40CH	–

Multi-function Digital Output Functions

Setting Value	Function	Page
0	During run 1 (ON: run command is ON or voltage is being output)	6-64
1	Zero speed	6-65
2	f_{ref}/f_{out} agree 1 (detection width L4-02 is used.)	6-25
3	f_{ref}/f_{set} agree 1 (ON: Output frequency = \pm L4-01, with detection width L4-02 used and during frequency agree)	6-25
4	Frequency detection 1 (ON: $+L4-01 \geq$ output frequency $\geq -L4-01$, detection width L4-02 used)	6-25
5	Frequency detection 2 (ON: Output frequency $\geq +L4-01$ or output frequency $\leq -L4-01$, detection width L4-02 used)	6-25

Setting Value	Function	Page
6	Inverter operation ready READY: After start-up or no faults	6-65
7	During DC bus undervoltage (UV) detection	6-65
8	During baseblock (NO contact, ON: during baseblock)	6-65
9	Frequency reference source selection (ON: Frequency reference from Operator)	6-65
A	Run command source selection status (ON: Run command from Operator)	6-65
B	Load detection NO (NO contact, ON: overload/loss of load detected)	6-30
C	Loss of frequency reference (Effective when I is set for L4-05)	6-44
E	Fault (ON: Digital Operator communications error or fault other than CPF00 and CPF01 has occurred.)	6-65
F	Not used. (Set when the terminal is not used.)	-
10	Minor Fault (Alarm) (ON: Alarm displayed)	6-65
11	Fault reset command active	6-66
12	Timer function output	6-86
17	Load Detection NC (NC contact, OFF: overload/loss of load detected)	6-30
1A	Reverse direction	6-66
1E	Restart enabled (ON: Restart enabled)	6-45
1F	During motor overload (OL1, including OH3) pre-alarm (ON: 90% or more of the detection level)	6-33
20	OH pre-alarm (temperature reached L8-02)	6-66
38	Drive enabled	6-66
39	Drive waiting (start delay time b1-11 is active)	6-66
3A	During OH and reduced Frequency	6-66
3B	RUN command from option card/communications	6-66
3D	Cooling fan fault (ON: internal cooling fan error)	6-66

■ Analog Inputs: H3

Parameter Number	Name	Description	Setting Range	Factory Setting	Change during Operation	Access Level	MEMO-BUS Register	Page
H3-02	Terminal A1 gain	Sets the frequency reference value when 10 V is input as a percentage of the maximum output frequency set in E1-04.	0.0 to 1000.0	100.0%	Yes	A	411H	6-21
H3-03	Terminal A1 bias	Sets the frequency reference value when 0 V is input as a percentage of the maximum output frequency set in E1-04.	-100.0 to +100.0	0.0%	Yes	A	412H	6-21
H3-08	Analog input A2 signal level selection	Selects the signal level input at multi-function analog input A2. 0: 0 to +10V (11 bit). 2: 4 to 20 mA (9-bit input). 3: 0 to 20 mA (9-bit input)	0, 2, 3	2	No	A* ₁	417H	6-21
H3-09	Analog input A2 function selection.	Selects the multi-function analog input function for terminal A2. Refer to the table H3-09 Settings for the explanation of the setting range.	0 to 1F	2* ₂	No	A* ₁	418H	6-21

Parameter Number	Name	Description	Setting Range	Factory Setting	Change during Operation	Access Level	MEMO-BUS Register	Page
H3-10	Terminal A2 gain	Sets the value of the function signal when 10 V (20 mA) is input as a percentage of the maximum value.	0.0 to 1000.0	100.0%	Yes	A	419H	6-21
H3-11	Terminal A2 bias	Sets the value of the function signal when 0 V (0/4 mA) is input as a percentage of the maximum value.	-100.0 to +100.0	0.0%	Yes	A	41AH	6-21
H3-12	Analog input filter time constant	Sets input filter time constant for the two analog input terminals (A1 and A2). Effective for noise suppression etc.	0.00 to 2.00	0.30 sec.	No	A	41BH	6-21
H3-13	Terminal A1/A2 switching	Selects on which terminal the main frequency reference can be input. 0: Use analog input 1 on terminal A1 for main frequency reference. 1: Use analog input 2 on terminal A2 for main frequency reference.	0 or 1	0	No	A*1	41CH	6-21

*1. Parameter is also available in Quick Programming Mode when PI controller is enabled, otherwise parameter is only available in Advanced Programming Mode.

*2. Setting switched to "B" when PI controller is enabled

H3-09 Settings

Setting Value	Function	Contents (100%)	Page
0	Frequency bias	Maximum output frequency	6-22
2	Auxiliary frequency reference (is used as frequency reference 2)	Maximum output frequency	6-7
B	PI feedback	Maximum output frequency	6-87
D	Frequency Bias 2	Maximum output frequency	6-22
E	Motor temperature input	—	6-35
16	PI differential input	Maximum output frequency	6-87
1F	Analog input not used.	—	—

■ Multi-function Analog Outputs: H4

Parameter Number	Name	Description	Setting Range	Factory Setting	Change during Operation	Access Level	MEMO-BUS Register	Page
H4-01	Terminal FM monitor selection	Sets the number of the monitor item to be output (U1-□□) at terminal FM.	1 to 53	2	No	A	41DH	6-67
H4-02	Terminal FM gain	Sets the analog output FM gain. Sets the percentage of the monitor value that is equal to 10 V output at terminal FM. Note that the maximum output voltage is 10 V.	0 to 1000.0 %	100%	Yes	A	41EH	6-67
H4-03	Terminal FM bias	Sets the analog output FM bias. Sets the percentage of the monitor item that is equal to 0 V output at terminal FM. The maximum output from the terminal is 10 V.	-110.0 to +110.0 %	0.0%	Yes	A	41FH	6-67
H4-04	Terminal AM monitor selection	Sets the number of the monitor item to be output (U1-□□) at terminal FM.	1 to 53	8	No	A	420H	6-67
H4-05	Terminal AM gain	Sets the analog output AM gain. Sets the percentage of the monitor value that is equal to 10V output at terminal AM. Note that the maximum output voltage is 10V.	0 to 1000.0 %	50.0%	Yes	A	421H	6-67
H4-06	Terminal AM bias	Sets the analog output AM bias. Sets the percentage of the monitor item that is equal to 0 V output at terminal AM. The maximum output from the terminal is 10 V.	-110.0 to +110.0 %	0.0%	Yes	A	422H	6-67
H4-07	Terminal FM signal level selection	Sets the signal output level for multi-function output 1 (terminal FM) 0: 0 to +10 V output 2: 4 – 20 mA ^{*1}	0 or 2	0	No	A	423H	6-67
H4-08	Terminal AM signal level selection	Sets the signal output level for multi-function output 2 (terminal AM) 0: 0 to +10 V output 2: 4 – 20 mA ^{*1}	0 or 2	0	No	A	424H	6-67

*1. An analog output signal of 4 - 20 mA requires an optional terminal board (ETC618121) for current output

MEMOBUS Communications: H5

Parameter Number	Name	Description	Setting Range	Factory Setting	Change during Operation	Access Level	MEMO-BUS Register	Page
H5-01	Station address	Sets the Inverter's node address.	0 to 20 *1	1F	No	A	425H	6-69
H5-02	Communications speed selection	Sets the baud rate for MEMOBUS communications. 0: 1200 bps 1: 2400 bps 2: 4800 bps 3: 9600 bps 4: 19200 bps	0 to 4	3	No	A	426H	6-69
H5-03	Communications parity selection	Sets the parity for MEMOBUS communications. 0: No parity 1: Even parity 2: Odd parity	0 to 2	0	No	A	427H	6-69
H5-04	Stopping method after communications error	Sets the stopping method for communications errors. 0: Deceleration to stop using the deceleration time in C1-02 1: Coast to stop 2: Emergency stop using the deceleration time in C1-09 3: Continue operation	0 to 3	3	No	A	428H	6-69
H5-05	Communications error detection selection	Sets whether or not a communications time out is to be detected as a communications error. 0: Not detected 1: Detect	0 or 1	1	No	A	429H	6-69
H5-06	Send wait time	Sets the time the Inverter waits until a response is sent to the Master.	5 to 65	5 msec	No	A	42AH	6-69
H5-07	RTS control ON/OFF	Enables or disables RTS control. 0: Disabled (RTS is always ON) 1: Enabled (RTS turns ON only when sending)	0 or 1	1	No	A	42BH	6-69
H5-08	Communication Selection	Selects the Protocol for the Communication 0: Memobus 1: N2 (Metasys)	0, 1	0	No	A	434H	6-69
H5-09	CE detection time	Sets the time before CE error (Communication error) is detected when MEMOBUS communication is used.	0.0 to 10.0 sec	2.0 sec	No	A	435H	6-69

*1. Set H5-01 to 0 to disable Inverter responses to MEMOBUS communications

◆ Protection Function Parameters: L

■ Motor Overload: L1

Parameter Number	Name	Description	Setting Range	Factory Setting	Change during Operation	Access Level	MEMO-BUS Register	Page
L1-01	Motor protection selection	Sets whether the motor overload function is enabled or disabled at electric thermal overload relay. 0: Disabled 1: General-purpose motor protection (fan cooled motor) 2: Inverter motor protection (externally cooled motor) 3: Vector motor protection When several motors are connected to one Inverter, set to 0 and ensure that each motor is installed with a protection device.	0 or 3	1	No	A	480H	6-33
L1-02	Motor protection time constant	Sets the electric thermal detection time in units of minutes. Usually changing this setting is not necessary. The factory setting is 150% overload for one minute. When the motor's overload capability is known, also set the overload resistance protection time for when the motor is hot started.	0.1 to 5.0	1.0 min	No	A	481H	6-33
L1-03	Alarm operation selection during motor overheating	Selects the operation when the input motor temperature (thermistor) input exceeds the alarm detection level (1.17 V) (H3-09 must be set to E). 0: Decelerate to stop 1: Coast to stop 2: Emergency stop using the deceleration time in C1-09. 3: Continue operation (oH3 on the Operator display flashes).	0 to 3	3	No	A	482H	6-35
L1-04	Motor overheating operation selection	Selects the operation when the motor temperature (thermistor) input exceeds the overheating detection level (2.34 V) (H3-09 must be set to E). 0: Decelerate to stop 1: Coast to stop 2: Emergency stop using the deceleration time in C1-09.	0 to 2	1	No	A	483H	6-35
L1-05	Motor temperature input filter time constant	Sets the delay time constant for the motor temperature (thermistor) input (H3-09=E) in seconds.	0.00 to 10.00	0.20 sec.	No	A	484H	6-35

■ Power Loss Ride Through: L2

Parameter Number	Name	Description	Setting Range	Factory Setting	Change during Operation	Access Level	MEMO-BUS Register	Page
L2-01	Momentary power loss detection	0: Disabled (DC bus undervoltage (UV1) detection) 1: Enabled (Restarted when the power returns within the time set in L2-02. When L2-02 is exceeded, DC bus undervoltage is detected.) 2: Enabled while CPU is operating. (Restarts when power returns during control operations. Does not detect DC bus undervoltage.)	0 to 2	0	No	A	485H	6-38
L2-02	Momentary power loss ride through time	Ride through time, when Momentary Power Loss Selection (L2-01) is set to 1.	0 to 25.5	0.1 sec. *1	No	A	486H	6-38
L2-03	Min. baseblock time	Sets the Inverter's minimum baseblock time, when the Inverter is restarted after power loss ride-through. Set the time to approximately 0.7 times the motor time constant. If an overcurrent or overvoltage occurs when starting a speed search or DC injection braking, increase the set values.	0.1 to 5.0	0.1 sec. *1	No	A	487H	6-38 6-39
L2-04	Voltage recovery time	Sets the time required to return the Inverter output voltage from 0V to normal voltage at the completion of a speed search.	0.0 to 5.0	0.3 sec. *1	No	A	488H	6-38 6-39
L2-05	Undervoltage detection level	Sets the main circuit undervoltage (UV) detection level (main circuit DC voltage). Usually changing this setting is not necessary.	150 to 210 *2	190 VDC *2	No	A	489H	6-38

*1. The factory setting depends on the Inverter capacity. The value for a 200 V Class Inverter of 0.4 kW is given.

*2. These are values for a 200 V class Inverter. Values for a 400 V class Inverter are double

■ Stall Prevention: L3

Parameter Number	Name	Description	Setting Range	Factory Setting	Change during Operation	Access Level	MEMO-BUS Register	Page
L3-01	Stall prevention selection during accel	<p>0: Disabled (Acceleration as set. With a heavy load, the motor may stall.)</p> <p>1: Enabled (Acceleration stopped when L3-02 level is exceeded. Acceleration starts again when the current has fallen below the stall prevention level).</p> <p>2: Intelligent acceleration mode (Using the L3-02 level as a basis, acceleration is automatically adjusted. Set acceleration time is disregarded.)</p>	0 to 2	1	No	A	48FH	6-17
L3-02	Stall prevention level during accel	<p>Effective when L3-01 is set to 1 or 2.</p> <p>Set as a percentage of Inverter rated current.</p> <p>Usually changing this setting is not necessary. Reduce the setting when the motor stalls.</p>	0 to 200	120%	No	A	490H	6-17
L3-04	Stall prevention selection during decel	<p>0: Disabled (Deceleration as set. If deceleration time is too short, a DC bus overvoltage may result.)</p> <p>1: Enabled (Deceleration is stopped when the DC bus voltage exceeds the stall prevention level. Deceleration restarts when the voltage falls below the stall prevention level again.)</p> <p>2: Intelligent deceleration mode (Deceleration rate is automatically adjusted so that the Inverter can decelerate in the shortest possible time. The set deceleration time is disregarded.)</p> <p>When a braking option (Braking Unit) is used, always set to 0.</p>	0 to 2	1	No	A	492H	6-19
L3-05	Stall prevention selection during running	<p>0: Disabled (Runs as set. With a heavy load, the motor may stall.)</p> <p>1: Deceleration using deceleration time 1 (C1-02.)</p> <p>2: Deceleration using deceleration time 2 (C1-04.)</p>	0 to 2	1	No	A	493H	6-29
L3-06	Stall prevention level during running	<p>Effective when L3-05 is 1 or 2.</p> <p>Set as a percentage of the Inverter rated current.</p> <p>Usually changing this setting is not necessary.</p> <p>Reduce the setting when the motor stalls.</p>	30 to 200	120%	No	A	494H	6-29

Reference Detection: L4

Parameter Number	Name	Description	Setting Range	Factory Setting	Change during Operation	Access Level	MEMO-BUS Register	Page
L4-01	Speed agreement detection level	Sets the detection level for the reference detection function. Effective when a multi-function output is set to: - 3 ("f _{out} = f _{set} agree"), - 4 ("Frequency detection 1") or - 5 ("Frequency detection 2").	0.0 to 200.0	0.0 Hz	No	A	499H	6-25
L4-02	Speed agreement detection width	Sets the hysteresis for the reference detection function. Effective when a multi-function output is set to: - 2 ("f _{ref} = f _{out} agree"), - 3 ("f _{out} = f _{set} agree"), - 4 ("Frequency detection 1") or - 5 ("Frequency detection 2").	0.0 to 20.0	2.0 Hz	No	A	49AH	6-25
L4-05	Operation when frequency reference is missing	0: Deceleration to Stop 1: Operation continues at the frequency set in parameter L4-06. Frequency reference loss means that the frequency reference value drops over 90% in 400 ms.	0 or 1	1	No	A	49DH	6-44
L4-06	Frequency reference value at frequency reference loss	Sets the frequency reference value as a percentage of the previous frequency reference, in case the frequency reference signal is lost.	0.0 to 100.0%	80%	No	A	4C2H	6-44

Fault Restart: L5

Parameter Number	Name	Description	Setting Range	Factory Setting	Change during Operation	Access Level	MEMO-BUS Register	Page
L5-01	Number of auto restart attempts	Sets the number of auto restart attempts. Automatically restarts after a fault and conducts a speed search from the run frequency.	0 to 10	0	No	A	49EH	6-45
L5-02	Auto restart operation selection	Sets whether a fault relay is activated during fault restart. 0: No output (Fault relay is not activated.) 1: Output (Fault relay is activated.)	0 or 1	0	No	A	49FH	6-45
L5-03	Fault Retry time	Sets the maximum time, the restart is tried.	0.5 to 180.0	10.0 sec	No	A	4A0H	6-45

■ Load Detection: L6

Parameter Number	Name	Description	Setting Range	Factory Setting	Change during Operation	Access Level	MEMO-BUS Register	Page
L6-01	Load detection selection	0: Load detection disabled. 1: Overload detection only at speed agree; operation continues (alarm). 2: Overload detection continuously during operation; operation continues (alarm). 3: Overload detection only at speed agree; coast to stop (fault). 4: Overload detection continuously during operation; coast to stop (fault). 5: Loss of load detection only at speed agree; operation continues (alarm). 6: Loss of load detection continuously during operation; operation continues (alarm). 7: Loss of Load detection only at speed agree; coast to stop (fault). 8: Loss of Load detection continuously during operation; coast to stop (fault).	0 to 8	6	No	A	4A1H	6-30
L6-02	Load detection level	Inverter rated current is set as 100%.	0 to 300	15%	No	A	4A2H	6-30
L6-03	Load detection time	Sets the overload/loss of load detection time.	0.0 to 10.0	10.0 sec.	No	A	4A3H	6-30

■ Hardware Protection: L8

Parameter Number	Name	Description	Setting Range	Factory Setting	Change during Operation	Access Level	MEMO-BUS Register	Page
L8-02	Overheat pre-alarm level	Sets the detection temperature for the Inverter overheat detection pre-alarm in °C.	50 to 130	95 °C*1	No	A	4AEH	6-47
L8-03	Operation selection after overheat pre-alarm	Sets the operation for when the Inverter overheat pre-alarm occurs. 0: Decelerate to stop using the deceleration time C1-02. 1: Coast to stop 2: Fast stop in fast-stop time C1-09. 3: Continue operation (Monitor display only.) 4: OH-Alarm and output frequency reduction (L8-19) A fault will be given in setting 0 to 2 and a alarm will be given in setting 3 and 4.	0 to 4	4	No	A	4AFH	6-47
L8-06	Input Phase Loss Detection Level	Allowed DC bus ripple before Input Phase Loss is detected.	0.0 to 25.0%	5%*1	No	A	4B2H	6-48
L8-09	Ground fault protection selection	0: Disabled 1: Enabled It is not recommended to use another setting than factory setting.	0 or 1	1	No	A	4B5H	6-48
L8-10	Cooling Fan control selection	Sets the ON/OFF control for the cooling fan. 0: ON only when RUN command is on 1: ON whenever inverter is powered up	0 or 1	0	No	A	4B6H	6-49
L8-11	Cooling fan control delay time	Set the time in seconds to delay turning OFF the cooling fan after the inverter STOP command is given.	0 to 300	300 sec.	No	A	4B7H	6-49
L8-12	Ambient temperature	Set the ambient temperature.	45 to 60	45 °C	No	A	4B8H	6-49
L8-15	OL2 characteristics selection at low speeds	0: OL2 characteristics at low speeds disabled. 1: OL2 characteristics at low speeds enabled. It is not recommended to use another setting than factory setting.	0 or 1	1	No	A	4BBH	6-50
L8-18	Soft CLA selection	0: Disable 1: Enable It is not recommended to use another setting than factory setting.	0 or 1	1	No	A	4BEH	6-51
L8-19	Frequency reference during OH pre-alarm	Sets the frequency reference when OH pre-alarm is detected in percent of maximum frequency	0.0 to 100.0	20.0%	No	A	4BFH	6-47
L8-32	OH1 detection selection for fan failure	Selects whether or not a failure of the internal fan leads to OH1. 0: Disabled (FAN alarm is displayed) 1: Enabled (OH1 fault occurs)	0 or 1	1	No	A	4E2H	6-49

*1. The factory setting depends on the Inverter capacity and the protection class. The value for a 200 V Class Inverter of 0.4 kW in protection class IP00 or IP20 / NEMA 1 is given.

◆ Special Adjustments: n

■ Hunting Prevention Function: n1

Parameter Number	Name	Description	Setting Range	Factory Setting	Change during Operation	Access Level	MEMO-BUS Register	Page
n1-01	Hunting prevention function selection	0: Hunting prevention function disabled 1: Hunting prevention function enabled	0 or 1	1	No	A	580H	6-28
n1-02	Hunting prevention gain	Sets the hunting prevention gain.	0.00 to 2.50	1.00	No	A	581H	4-11 6-28

■ High Slip Braking: n3

Parameter Number	Name	Description	Setting Range	Factory Setting	Change during Operation	Access Level	MEMO-BUS Register	Page
n3-01	High Slip braking deceleration frequency width	Sets the frequency width for deceleration during High Slip braking in percent of FMAX (E1-04).	1 to 20	5%	No	A	588H	6-109
n3-02	High Slip braking current limit	Sets the current limit for deceleration during High Slip braking in percent of the motor rated current. The resulting limit must be 120% of the Inverter rated current or less.	100 to 200	150%	No	A	589H	6-109
n3-03	High Slip braking stop dwell time	Sets the dwell time for the output frequency for FMIN (1.5 Hz) after High Slip Braking.	0.0 to 10.0	1.0 sec.	No	A	58AH	6-109
n3-04	High Slip braking OL7 time	Sets the time until OL7 occurs if the output frequency does not change for any reason during High Slip braking.	30 to 1200	40 sec.	No	A	58BH	6-109

◆ Digital Operator Parameters: o

■ Monitor Select: o1

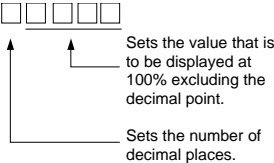
Parameter Number	Name	Description	Setting Range	Factory Setting	Change during Operation	Access Level	MEMO-BUS Register	Page
o1-01	Monitor selection *1	Sets the number of the 4th monitor item to be displayed in the Drive Mode (U1-□□). (Only on LED Digital Operator.)	6 to 53	6	Yes	A	500H	6-110
o1-02	Monitor selection after power up	Sets the monitor item to be displayed when the power is turned on. 1: Frequency reference 2: Output frequency 3: Output current 4: The monitor item set for o1-01	1 to 4	1	Yes	A	501H	6-110
o1-03	Digital operator display scaling	Sets the units that will be set and displayed for the frequency reference and frequency monitor. 0: 0.01 Hz units 1: 0.01% units (Maximum output frequency is 100%) 2 to 39: rpm units (Set the motor poles.) 40 to 39999: User desired display Set the desired values for setting and display for the max. output frequency.  Example: When the max. output value is 200.0, set 12000	0 to 39999	0	No	A	502H	6-111
o1-05	LCD-Focus	Sets the brightness on the LCD Digital Operator. 0: light 1: 2: 3: normal 4: 5: dark	0 to 5	3	Yes	A	504H	—
o1-06	Monitor Mode Selection *2	0: Below the active monitor parameter the next 2 sequential monitors are displayed. 1: Below the active monitor the 2 monitors specified by o1-07 and o1-08 are locked	0 or 1	0	No	A	517H	—
o1-07	2nd Monitor Selection *2	Selects the monitor that is displayed and locked in the second line of the operator display.	1 to 53	2	No	A	518H	—

Parameter Number	Name	Description	Setting Range	Factory Setting	Change during Operation	Access Level	MEMO-BUS Register	Page
o1-08	3rd Monitor Selection*2	Selects the monitor that is displayed and locked in the third line of the operator display.	1 to 53	3	No	A	519H	–
o1-09	Frequency reference display unit selection*2	Sets the unit display for the frequency reference related monitors when o1-03 \geq 40. Refer to o1-09 Settings for the setting range.	0 to 11	0	No	A	619H	6-III

*1. Parameter function is only valid if the LED Digital Operator is used.

*2. Parameter function is only valid if a Digital Operator with LCD clear text display is used (LCD or HOA Digital Operator).

o1-09 Settings

Setting Value	Function	Displayed Unit
0	WC: Inch of water column	WC
1	PSI: lb/square inch	PSI
2	GPM: Gallons per minute	GPM
3	F: Degree Fahrenheit	F
4	CFM: Cubic feet per minute	CFM
5	CMH: Cubic meter per hour	CMH
6	LPH: Liters per hour	LPH
7	LPS: Liters per second	LPS
8	Bar: Bar	Bar
9	Pa: Pascal	Pa
10	C: Degree Celsius	C
11	Mtr: Meters	Mtr

Multi-function Selections: o2

Parameter Number	Name	Description	Setting Range	Factory Setting	Change during Operation	Access Level	MEMO-BUS Register	Page
o2-01	LOCAL/REMOTE key enable/disable *1	Enables/disables the LOCAL/REMOTE key 0: Disabled 1: Enabled (Switches between the Digital Operator and the parameter settings b1-01, b1-02.)	0 or 1	1	No	A	505H	6-112
o2-02	STOP key during control circuit terminal operation *1	Enables/disables the STOP key 0: Disabled (When the run command is issued from an external terminal, the Stop key is disabled.) 1: Enabled (Effective even during run.)	0 or 1	1	No	A	506H	6-112
o2-03	User parameter initial value	Clears or stores user initial values. 0: Stored/not set 1: Begins storing (Records the set parameters as user initial values.) 2: Clearing memory (Clears all recorded user initial values) When the set parameters are recorded as user initial values, 1110 can be set in A1-03 to recall them.	0 to 2	0	No	A	507H	6-112
o2-04	kVA selection	Do not set unless after replacing the control board. (Refer to page 5-47 for the setting values)	0 to FF	0*2	No	A	508H	5-47
o2-05	Frequency reference setting method selection	When the frequency reference is set on the Digital Operator frequency reference monitor, sets whether the Enter key is necessary or not. 0: Enter key needed 1: Enter key not needed	0 or 1	0	No	A	509H	6-112
o2-06	Operation selection when digital operator is disconnected	Sets the operation when the Digital Operator is disconnected. 0: Disabled (Operation continues even if the Digital Operator is disconnected.) 1: Enabled (OPR is detected at Digital Operator disconnection. Inverter output is switched off, and fault relay is operated.)	0 or 1	0	No	A	50AH	6-112
o2-07	Cumulative operation time setting	Sets the cumulative operation time. The operation time is accumulated from the set value.	0 to 65535	0 hrs	No	A	50BH	6-112
o2-08	Cumulative operation time selection	0: Accumulated Inverter power on time 1: Accumulated Inverter run time.	0 or 1	1	No	A	50CH	6-112
o2-09	Initialize Mode	2: Europe Spec. 5: PV-E Spec. 6: Chinese Spec.	2, 5, 6	2	No	A	50DH	-

Parameter Number	Name	Description	Setting Range	Factory Setting	Change during Operation	Access Level	MEMO-BUS Register	Page
o2-10	Fan operation time setting	Sets the initial value of the fan operation time. The fan operation time is accumulated from the set value.	0 to 65535	0 hr.	No	A	50EH	6-112
o2-12	Fault trace initialize	0: No change 1: Initialized. After setting "1" o2-12 will return to "0"	0 or 1	0	No	A	511H	6-112
o2-14	kWh monitor initialize	Resets the monitor parameters U1-29 and U1-30 back to zero. 0: No change 1: Reset to zero	0 or 1	0	No	A	512H	6-112
o2-15	HAND Key function selection *3	If set to 0 the HAND key on the HOA Digital Operator is disabled and the Inverter will not enter the HAND mode and start to run when the HAND key is pressed. 0: HAND key disabled 1: HAND key enabled	0 or 1	0	No	A	513H	6-113
o2-17	Standard / IP54 Selection	Selects whether the Inverter is in standard (IP00 or NEMA 1 / IP20) or IP54 protection class. 0: IP00 or NEMA 1 / IP20 1: IP54	0 or 1	*4	No	*5	51BH	6-113

*1. This parameter is effective only when the LED or LCD Digital Operator is used.

*2. The factory setting depends on the Inverter capacity. The value for a 200 V Class Inverter of 0.4 kW is given.

*3. This parameter is effective only when the HOA operator JVOP-162 is used.

*4. Factory setting depends on the protection class of the Inverter.

*5. The access level depends on the setting of o2-09: When o2-09 is set to "2" or "5" parameter o2-17 is accessible.

■ Copy Function: o3

Parameter Number	Name	Description	Setting Range	Factory Setting	Change during Operation	Access Level	MEMO-BUS Register	Page
o3-01	Copy function selection	0: Normal operation 1: READ (Inverter to Operator) 2: COPY (Operator to Inverter) 3: Verify (compare)	0 to 3	0	No	A	515H	6-113
o3-02	Read permission selection	0: READ prohibited 1: READ permitted	0 or 1	0	No	A	516H	6-113

◆ Motor Autotuning: T

Parameter Number	Name	Description	Setting Range	Factory Setting	Change during Operation	Access Level	MEMO-BUS Register	Page
T1-02	Motor output power	Set the output power of the motor in Kilowatts.	0.00 to 650.00	0.40 kW *1	No	A	702H	4-7
T1-04	Motor rated current	Set the rated current of the motor in Amps.	0.32 to 6.40 *2	1.90 A *1	No	A	704H	4-7

*1. The factory setting depends on the Inverter capacity. The value for a 200 V Class Inverter of 0.4 kW is given.

*2. The setting range is 10% to 200% of the Inverter rated output current. The value for a 200 V class Inverter of 0.4 kW is given.

◆ Monitor Parameters: U

■ Status Monitor Parameters: U1

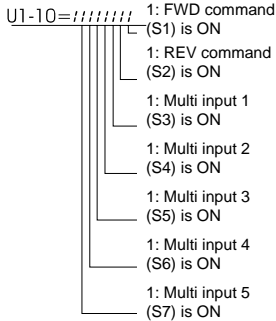
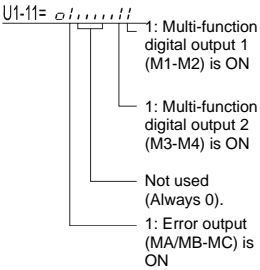
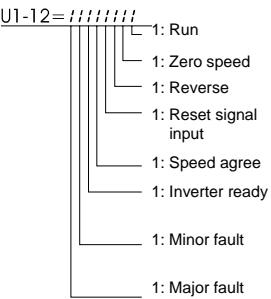
Parameter Number	Name	Description	Output Signal Level During Multi-Function Analog Output	Min. Unit	MEMO-BUS Register
U1-01	Frequency reference	Monitors/sets the frequency reference value.*1	10 V: Max. frequency	0.01 Hz	40H
U1-02	Output frequency	Monitors the output frequency.*1	10 V: Max. frequency	0.01 Hz	41H
U1-03	Output current	Monitors the output current.	10 V: Inverter rated output current	0.01 A	42H
U1-06	Output voltage	Monitors the output voltage reference.	10 V: 200 VAC (400 VAC)	0.1 V	45H
U1-07	DC bus voltage	Monitors the DC bus voltage.	10 V: 400 VDC (800 VDC)	1 V	46H
U1-08	Output power	Monitors the output power.	10 V: Inverter capacity (max. applicable motor capacity)	0.1 kW	47H
U1-10	Input terminal status	Shows input ON/OFF status. 	(Cannot be output.)	–	49H
U1-11	Output terminal status	Shows output ON/OFF status. 	(Cannot be output.)	–	4AH
U1-12	Operation status	Inverter operating status. 	(Cannot be output.)	–	4BH

Parameter Number	Name	Description	Output Signal Level During Multi-Function Analog Output	Min. Unit	MEMO-BUS Register
U1-13	Cumulative operation time	Monitors the total operating time of the Inverter. The initial value and the operating time/power ON time selection can be set in o2-07 and o2-08.	(Cannot be output.)	1 hr.	4CH
U1-14	Software No. (flash memory)	(Manufacturer's ID number)	(Cannot be output.)	–	4DH
U1-15	Terminal A1 input level	Monitors the input level of analog input A1. A value of 100% equals 10V input.	10 V: 100%	0.1%	4EH
U1-16	Terminal A2 input level	Monitors the input level of analog input A2. A value of 100% equals 10V/20mA input.	10 V/20mA: 100%	0.1%	4FH
U1-18	Motor secondary current (Iq)	Monitors the calculated value of the motor secondary current. The motor rated current corresponds to 100%.	10 V: Motor rated current	0.1%	51H
U1-20	Output frequency after soft-starter (SFS output)	Monitors the frequency reference after the soft starter. This frequency value does not include compensations, such as slip compensation.*1	10 V: Max. frequency	0.01 Hz	53H
U1-24	PI feedback value*2	Monitors the feedback value when PI control is used.*3	10 V: 100% feedback value	0.01 %	57H
U1-28	Software No. (CPU)	(CPU software No.)	(Cannot be output.)	–	5BH
U1-29	kWh display	Monitors the 4 lower digits, kWh display.	(Cannot be output.)	1 kWh	5CH
U1-30	MWh display	Monitors the 5 higher digits, MWh display.	(Cannot be output.)	0.1 MWh	5DH
U1-31	LED Test	For testing LEDs on operator. If this monitor is selected, all LED's light up (only on LED operator).	(Cannot be output.)	–	3CH
U1-34	OPE fault parameter	Shows the first parameter number when an OPE fault is detected.	(Cannot be output.)	–	61H
U1-36	PI input volume	PI input volume	10 V: 100% PI input	0.01 %	63H
U1-37	PI output volume	PI control output	10 V: 100% PI output	0.01 %	64H
U1-38	PI setpoint*2	PI setpoint*3	10 V: 100% PI setpoint	0.01 %	65H

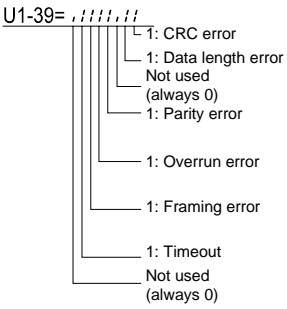
Parameter Number	Name	Description	Output Signal Level During Multi-Function Analog Output	Min. Unit	MEMO-BUS Register
U1-39	MEMOBUS communications error code	Shows MEMOBUS errors. 	(Cannot be output.)	—	66H
U1-40	Cooling fan operating time	Monitors the total operating time of the cooling fan. The time can be set in o2-10.	(Cannot be output.)	1 hr.	68H
U1-51	Frequency reference at AUTO operation	Monitors the value of the frequency reference when AUTO operation is active.	10 V: Max. frequency	0.01 %	72H
U1-52	Frequency reference at HAND operation	Monitors the value of the frequency reference when HAND operation is active.	10 V: Max. frequency	0.01 %	73H
U1-53	PI feedback 2	Monitors the feedback value of the PI fdbk2 input when Differential PI is selected (H3-□□=6B)	10V: 100% feedback value	0.01 %	74H

*1. The monitor parameter can be scaled in o1-03, the unit can be set in o1-09.

*2. The monitor parameters will be moved up to 2nd and 3rd position when the PI controller is enabled.

*3. The monitor parameter can be scaled in b5-20, the unit can be set in b5-31.

■ Fault Trace: U2

Parameter Number	Name	Description	Output Signal Level During Multi-Function Analog Output	Min. Unit	MEMO-BUS Register
U2-01	Current fault	The content of the current fault.	(Cannot be output.)	–	80H
U2-02	Last fault	The error content of the last fault.		–	81H
U2-03	Reference frequency at fault	The reference frequency when the last fault occurred.		0.01 Hz	82H
U2-04	Output frequency at fault	The output frequency when the last fault occurred.		0.01 Hz	83H
U2-05	Output current at fault	The output current when the last fault occurred.		0.01 A	84H
U2-07	Output voltage reference at fault	The output reference voltage when the last fault occurred.		0.1 V	86H
U2-08	DC bus voltage at fault	The DC bus voltage when the last fault occurred.		1 V	87H
U2-09	Output power at fault	The output power when the last fault occurred.		0.1 kW	88H
U2-11	Input terminal status at fault	The input terminal status when the last fault occurred. The format is the same as for U1-10.		–	8AH
U2-12	Output terminal status at fault	The output terminal status when the last fault occurred. The format is the same as for U1-11.		–	8BH
U2-13	Operation status at fault	The operating status when the last fault occurred. The format is the same as for U1-12.		–	8CH
U2-14	Cumulative operation time at fault	The operating time when the last fault occurred.		1 hr.	8DH

Note: The following errors are not included in the error trace: CPF00, 01, 02, 03, UV1, and UV2.

■ Fault History: U3

Parameter Number	Name	Description	Output Signal Level During Multi-Function Analog Output	Min. Unit	MEMO-BUS Register
U3-01	Last fault	The error content of 1st last fault.	(Cannot be output.)	–	90H
U3-02	Second last fault	The error content of 2nd last fault.		–	91H
U3-03	Third last fault	The error content of 3rd last fault.		–	92H
U3-04	Fourth last fault	The error content of 4th last fault.		–	93H
U3-05	Cumulative operation time at fault	The total operating time when the 1st previous fault occurred.		1 hr.	94H
U3-06	Accumulated time of second fault	The total operating time when the 2nd previous fault occurred.		1 hr.	95H
U3-07	Accumulated time of third fault	The total operating time when the 3rd previous fault occurred.		1 hr.	96H
U3-08	Accumulated time of fourth/oldest fault	The total operating time when the 4th previous fault occurred.		1 hr.	97H
U3-09 – U3-14	Fifth last to tenth last fault	The error content of the 5th to 10th last fault		–	804 805H 806H 807H 808H 809H
U3-15 – U3-20	Accumulated time of fifth to tenth fault	Total generating time when 5th... 10th previous fault occurred		1 hr.	806H 80FH 810H 811H 812H 813H

Note: The following errors are not recorded in the error log: CPF00, 01, 02, 03, UV1, and UV2.

◆ Setting Values that Change with the V/f Pattern Selection (E1-03)

■ 200 V and 400 V Class Inverters of 0.4 to 1.5 kW

Parameter Number	Unit	Factory Setting																
		0	1	2	3	4	5	6	7	8	9	A	B	C	D	E	F	FF
E1-03	-	0	1	2	3	4	5	6	7	8	9	A	B	C	D	E	F	FF
E1-04	Hz	50.0	60.0	60.0	72.0	50.0	50.0	60.0	60.0	50.0	50.0	60.0	60.0	90.0	120.0	180.0	50.0	50.0
E1-05 *1	V	200.0	200.0	200.0	200.0	200.0	200.0	200.0	200.0	200.0	200.0	200.0	200.0	200.0	200.0	200.0	200.0	200.0
E1-06	Hz	50.0	60.0	50.0	60.0	50.0	50.0	60.0	60.0	50.0	50.0	60.0	60.0	60.0	60.0	60.0	50.0	50.0
E1-07 *1	Hz	2.5	3.0	3.0	3.0	25.0	25.0	30.0	30.0	2.5	2.5	3.0	3.0	3.0	3.0	3.0	2.5	2.5
E1-08 *1	V	15.0	15.0	15.0	15.0	35.0	50.0	35.0	50.0	19.0	24.0	19.0	24.0	15.0	15.0	15.0	15.0	12.0
E1-09	Hz	1.3	1.5	1.5	1.5	1.3	1.3	1.5	1.5	1.3	1.3	1.5	1.5	1.5	1.5	1.5	1.2	1.2
E1-10 *1	V	9.0	9.0	9.0	9.0	8.0	9.0	8.0	9.0	11.0	13.0	11.0	15.0	9.0	9.0	9.0	9.0	6.0

*1. These are values for a 200 V class Inverter. Values for a 400 V class Inverter are double

■ 200 V and 400 V Class Inverters of 2.2 to 45 kW

Parameter Number	Unit	Factory Setting																
		0	1	2	3	4	5	6	7	8	9	A	B	C	D	E	F	FF
E1-03	-	0	1	2	3	4	5	6	7	8	9	A	B	C	D	E	F	FF
E1-04	Hz	50.0	60.0	60.0	72.0	50.0	50.0	60.0	60.0	50.0	50.0	60.0	60.0	90.0	120.0	180.0	50.0	50.0
E1-05 *1	V	200.0	200.0	200.0	200.0	200.0	200.0	200.0	200.0	200.0	200.0	200.0	200.0	200.0	200.0	200.0	200.0	200.0
E1-06	Hz	50.0	60.0	50.0	60.0	50.0	50.0	60.0	60.0	50.0	50.0	60.0	60.0	60.0	60.0	60.0	50.0	50.0
E1-07 *1	Hz	2.5	3.0	3.0	3.0	25.0	25.0	30.0	30.0	2.5	2.5	3.0	3.0	3.0	3.0	3.0	2.5	2.5
E1-08 *1	V	14.0	14.0	14.0	14.0	35.0	50.0	35.0	50.0	18.0	23.0	18.0	23.0	14.0	14.0	14.0	14.0	15.0
E1-09	Hz	1.3	1.5	1.5	1.5	1.3	1.3	1.5	1.5	1.3	1.3	1.5	1.5	1.5	1.5	1.5	1.2	1.2
E1-10 *1	V	7.0	7.0	7.0	7.0	6.0	7.0	6.0	7.0	9.0	11.0	9.0	13.0	7.0	7.0	7.0	7.0	9.0

*1. These are values for a 200 V class Inverter. Values for a 400 V class Inverter are double

■ 200 V Class Inverters of 55 to 110 kW and 400 V Class Inverters of 55 to 300 kW

Parameter Number	Unit	Factory Setting																
		0	1	2	3	4	5	6	7	8	9	A	B	C	D	E	F	FF
E1-03	-	0	1	2	3	4	5	6	7	8	9	A	B	C	D	E	F	FF
E1-04	Hz	50.0	60.0	60.0	72.0	50.0	50.0	60.0	60.0	50.0	50.0	60.0	60.0	90.0	120.0	180.0	50.0	50.0
E1-05 *1	V	200.0	200.0	200.0	200.0	200.0	200.0	200.0	200.0	200.0	200.0	200.0	200.0	200.0	200.0	200.0	200.0	200.0
E1-06	Hz	50.0	60.0	50.0	60.0	50.0	50.0	60.0	60.0	50.0	50.0	60.0	60.0	60.0	60.0	60.0	50.0	50.0
E1-07 *1	Hz	2.5	3.0	3.0	3.0	25.0	25.0	30.0	30.0	2.5	2.5	3.0	3.0	3.0	3.0	3.0	2.5	2.5
E1-08 *1	V	12.0	12.0	12.0	12.0	35.0	50.0	35.0	50.0	15.0	20.0	15.0	20.0	12.0	12.0	12.0	12.0	14.0
E1-09	Hz	1.3	1.5	1.5	1.5	1.3	1.3	1.5	1.5	1.3	1.3	1.5	1.5	1.5	1.5	1.5	1.2	1.2
E1-10 *1	V	6.0	6.0	6.0	6.0	5.0	6.0	5.0	6.0	7.0	9.0	7.0	11.0	6.0	6.0	6.0	6.0	7.0

*1. These are values for a 200 V class Inverter. Values for a 400 V class Inverter are double

◆ Factory Settings that Change with the Inverter Capacity (o2-04)

■ 200 V Class Inverters

Parameter Number	Name	Unit	Factory Setting								
			0.4	0.75	1.5	2.2	3.7	5.5	7.5	11	15
–	Inverter Capacity	kW	0.4	0.75	1.5	2.2	3.7	5.5	7.5	11	15
o2-04	kVA selection	–	0	1	2	3	4	5	6	7	8
b8-04	Energy-saving coefficient	–	288.20	223.70	169.40	156.80	122.90	94.75	72.69	70.44	63.13
C6-02	Carrier frequency selection*1	Normal Duty 1	–	6	6	6	6	6	6	6	6
		Normal Duty 2	–	4	4	4	3	4	6	6	3
E2-01	Motor rated current	A	1.90	3.30	6.20	8.50	14.00	19.60	26.60	39.7	53.0
E2-03	Motor no-load current	A	1.20	1.80	2.80	3.00	4.50	5.10	8.00	11.2	15.2
E2-05	Motor line-to-line resistance	W	9.842	5.156	1.997	1.601	0.771	0.399	0.288	0.230	0.138
L2-02	Momentary power loss ride through time	sec.	0.1	0.1	0.2	0.3	0.5	1.0	1.0	1.0	2.0
L2-03	Min. baseblock (BB) time	sec.	0.1	0.2	0.3	0.4	0.5	0.6	0.7	0.8	0.9
L2-04	Voltage recovery time	sec.	0.3	0.3	0.3	0.3	0.3	0.3	0.3	0.3	0.3
L8-02	Overheat pre-alarm level	°C	95	95	95	95	95	95	95	95	95
L8-06	Input phase loss detection level	%	5.0	7.5	10.0	12.0	12.0	10.0	17.0	21.0	17.0

*1. The initial settings for C6-02 are as follows: 2: 5.0 kHz, 3: 8.0 kHz, 4: 10 kHz, 5: 12.5 kHz, and 6: 15 kHz. If the carrier frequency is set higher than the factory setting for Inverters with outputs of 30 kW or more, the Inverter rated current will need to be reduced.

Parameter Number	Name	Unit	Factory Setting								
			18.5	22	30	37	45	55	75	90	110
–	Inverter Capacity	kW	18.5	22	30	37	45	55	75	90	110
o2-04	kVA selection	–	9	A	B	C	D	E	F	10	11
b8-04	Energy-saving coefficient	–	57.87	51.79	46.27	38.16	35.78	31.35	23.10	23.10	23.10
C6-02	Carrier frequency selection*1	Normal Duty 1	–	6	6	6	6	6	6	6	6
		Normal Duty 2	–	4	4	4	3	4	6	6	3
E2-01	Motor rated current	A	65.8	77.2	105.0	131.0	160.0	190.0	260.0	260.0	260.0
E2-03	Motor no-load current	A	15.7	18.5	21.9	38.2	44.0	45.6	72.0	72.0	72.0
E2-05	Motor line-to-line resistance	W	0.101	0.079	0.064	0.039	0.030	0.022	0.023	0.023	0.023
L2-02	Momentary power loss ride through time	sec.	2.0	2.0	2.0	2.0	2.0	2.0	2.0	2.0	2.0
L2-03	Min. baseblock (BB) time	sec.	1.0	1.0	1.1	1.1	1.2	1.2	1.3	1.5	1.7
L2-04	Voltage recovery time	sec.	0.6	0.6	0.6	0.6	0.6	1.0	1.0	1.0	1.0
L8-02	Overheat pre-alarm level	°C	95	95	95	95	95	95	95	95	95
L8-06	Input phase loss detection level	%	15.0	24.0	20.0	18.0	20.0	17.0	16.0	18.0	20.0

*1. The initial settings for C6-02 are as follows: 2: 5.0 kHz, 3: 8.0 kHz, 4: 10 kHz, 5: 12.5 kHz, and 6: 15 kHz. If the carrier frequency is set higher than the factory setting for Inverters with outputs of 30 kW or more, the Inverter rated current will need to be reduced.

■ 400 V Class Inverters in Protection Class IP00 and NEMA 1 / IP20

Parameter Number	Name	Unit	Factory Setting									
			0.4	0.75	1.5	2.2	3.7	4.0	5.5	7.5	11	15
–	Inverter Capacity	kW	0.4	0.75	1.5	2.2	3.7	4.0	5.5	7.5	11	15
o2-04	kVA selection	–	20	21	22	23	24	25	26	27	28	29
b8-04	Energy-saving coefficient	–	576.40	447.40	338.80	313.60	245.80	236.44	189.50	145.38	140.88	126.26
C6-02	Carrier frequency selection *1	Normal Duty 1	–	6	6	6	6	6	6	6	6	6
		Normal Duty 2	–	6	6	6	6	6	6	6	6	3
E2-01	Motor rated current	A	1.00	1.60	3.10	4.20	7.00	7.00	9.80	13.30	19.9	26.5
E2-03	Motor no-load current	A	0.60	0.80	1.40	1.50	2.30	2.30	2.60	4.00	5.6	7.6
E2-05	Motor line-to-line resistance	W	38.198	22.459	10.100	6.495	3.333	3.333	1.595	1.152	0.922	0.550
L2-02	Momentary power loss ride through time	sec.	0.1	0.1	0.2	0.3	0.5	0.5	0.8	0.8	1.0	2.0
L2-03	Min. baseblock (BB) time	sec.	0.1	0.2	0.3	0.4	0.5	0.6	0.6	0.7	0.8	0.9
L2-04	Voltage recovery time	sec.	0.3	0.3	0.3	0.3	0.3	0.3	0.3	0.3	0.3	0.3
L8-02	Overheat pre-alarm level	°C	95	95	95	95	95	95	95	95	95	95
L8-06	Input phase loss detection	%	5.0	7.5	10.0	10.0	12.0	10.0	10.0	20.0	23.0	17.0

*1. The initial settings for C6-02 are as follows: 2: 5.0 kHz, 3: 8.0 kHz, 4: 10 kHz, 5: 12.5 kHz, and 6: 15 kHz. If the carrier frequency is set higher than the factory setting for Inverters with outputs of 30 kW or more, the Inverter rated current will need to be reduced.

Parameter Number	Name	Unit	Factory Setting										
			18.5	22	30	37	45	55	75	90	110	132	
–	Inverter Capacity	kW	18.5	22	30	37	45	55	75	90	110	132	
o2-04	kVA selection	–	2A	2B	2C	2D	2E	2F	30	31	32	33	
b8-04	Energy-saving coefficient	–	115.74	103.58	92.54	76.32	71.56	67.20	46.20	41.22	36.23	33.18	
C6-02	Carrier frequency selection *1	Normal Duty 1	–	6	6	4	4	4	4	3	3	3	2
		Normal Duty 2	–	4	4	3	3	3	2	2	3	2	2
E2-01	Motor rated current	A	32.9	38.6	52.3	65.6	79.7	95.0	130.0	156.0	190.0	223.0	
E2-03	Motor no-load current	A	7.8	9.2	10.9	19.1	22.0	24.0	36.0	40.0	49.0	58.0	
E2-05	Motor line-to-line resistance	W	0.403	0.316	0.269	0.155	0.122	0.088	0.092	0.056	0.046	0.035	
L2-02	Momentary power loss ride through time	sec.	2.0	2.0	2.0	2.0	2.0	2.0	2.0	2.0	2.0	2.0	
L2-03	Min. baseblock (BB) time	sec.	1.0	1.0	1.1	1.1	1.2	1.2	1.3	1.5	1.7	1.7	
L2-04	Voltage recovery time	sec.	0.6	0.6	0.6	0.6	0.6	1.0	1.0	1.0	1.0	1.0	
L8-02	Overheat pre-alarm level	°C	95	95	95	95	95	100	95	110	110	110	
L8-06	Input phase loss detection	%	17.0	20.0	20.0	20.0	20.0	20.0	20.0	16.0	16.0	16.0	

*1. The initial settings for C6-02 are as follows: 2: 5.0 kHz, 3: 8.0 kHz, 4: 10 kHz, 5: 12.5 kHz, and 6: 15 kHz. If the carrier frequency is set higher than the factory setting for Inverters with outputs of 30 kW or more, the Inverter rated current will need to be reduced.

Parameter Number	Name	Unit	Factory Setting				
–	Inverter Capacity	kW	160	185	220	300	
o2-04	kVA selection	–	34	35	36	37	
b8-04	Energy-saving coefficient	–	30.13	30.57	27.13	21.76	
C6-02	Carrier frequency selection *1	Normal Duty 1	–	2	2	1	1
		Normal Duty 2	–	2	1	1	1
E2-01	Motor rated current	A	270.0	310.0	370.0	500.0	
E2-03	Motor no-load current	A	70.0	81.0	96.0	130.0	
E2-05	Motor line-to-line resistance	W	0.029	0.025	0.020	0.014	
L2-02	Momentary power loss ride through time	sec.	2.0	2.0	2.0	2.0	
L2-03	Min. baseblock (BB) time	sec.	1.8	1.9	2.0	2.1	
L2-04	Voltage recovery time	sec.	1.0	1.0	1.0	1.0	
L8-02	Overheat pre-alarm level	°C	108	95	100	108	
L8-06	Input phase loss detection level	%	14.0	15.0	15.0	15.0	

*1. The initial settings for C6-02 are as follows: 2: 5.0 kHz, 3: 8.0 kHz, 4: 10 kHz, 5: 12.5 kHz, and 6: 15 kHz. If the carrier frequency is set higher than the factory setting for Inverters with outputs of 30 kW or more, the Inverter rated current will need to be reduced.

■ 400 V Class Inverters in Protection Class IP54

Parameter Number	Name	Unit	Factory Setting								
–	Inverter Capacity	kW	7.5	11	15	18.5	22	30	37	45	55
o2-04	kVA selection	–	67	68	69	6A	6B	6C	6D	6E	6F
b8-04	Energy-saving coefficient	–	145.38	140.88	126.26	115.74	103.58	92.54	76.32	71.56	67.20
C6-02	Carrier frequency selection *1	–	2	2	2	2	2	2	2	2	2
E2-01	Motor rated current	A	13.30	19.9	26.5	32.9	38.6	52.3	65.6	79.7	95.0
E2-03	Motor no-load current	A	4.00	5.6	7.6	7.8	9.2	10.9	19.1	22.0	24.0
E2-05	Motor line-to-line resistance	W	1.152	0.922	0.550	0.403	0.316	0.269	0.155	0.122	0.088
L2-02	Momentary power loss ride through time	sec.	0.8	1.0	2.0	2.0	2.0	2.0	2.0	2.0	2.0
L2-03	Min. baseblock (BB) time	sec.	0.7	0.8	0.9	1.0	1.0	1.1	1.1	1.2	1.2
L2-04	Voltage recovery time	sec.	0.3	0.3	0.3	0.6	0.6	0.6	0.6	0.6	1.0
L8-02	Overheat pre-alarm level	°C	90	95	95	98	87	87	85	86	86
L8-06	Input phase loss detection	%	20.0	23.0	17.0	17.0	20.0	20.0	20.0	20.0	20.0

*1. The initial settings for C6-02 are as follows: 2: 5.0 kHz, 3: 8.0 kHz, 4: 10 kHz, 5: 12.5 kHz, and 6: 15 kHz. If the carrier frequency is set higher than the factory setting for Inverters with outputs of 30 kW or more, the Inverter rated current will need to be reduced.





6

Parameter Settings by Function

Carrier Frequency Selection	6-2
Frequency Reference	6-5
Run Command.....	6-9
Stopping Methods	6-11
Acceleration and Deceleration Characteristics	6-15
Adjusting Frequency References.....	6-21
Speed Limit (Frequency Reference Limit Function).....	6-24
Frequency Detection.....	6-25
Improved Operating Performance.....	6-27
Machine Protection	6-29
Automatic Restart	6-38
Inverter Protection.....	6-47
Input Terminal Functions	6-52
Output Terminal Functions.....	6-64
Monitor Parameters	6-67
Individual Functions	6-69
Digital Operator Functions	6-110

Carrier Frequency Selection

◆ Setting the Carrier Frequency

Using the following parameters the carrier frequency setting can be fitted to the applications requirements.

■ Related Parameters

Parameter No.	Name	Setting Range	Factory Setting	Changes During Operation?	Access Level
C6-01	Normal duty selection	1 or 2	1	No	A
C6-02	Carrier frequency selection	0 to F	6 ^{*1}	No	A
C6-03	Carrier frequency upper limit	2.0 to 15.0 *2 *3	15.0 kHz *1	No	A
C6-04	Carrier frequency lower limit	0.4 to 15.0 *2*3	15.0 kHz *1	No	A
C6-05	Carrier frequency proportional gain	00 to 99 *3	00	No	A

*1. The factory setting depends on the Inverter capacity.

*2. The setting range depends on the Inverter capacity.

*3. This parameter can only be set when C6-02 is set to F.

■ Carrier Frequency, Current Derating and Overload Capability in Normal Duty 1 and 2

The Inverter overload capability depends among other things on the carrier frequency setting. If the carrier frequency setting is higher than the factory setting, the overload current capability must be reduced.

Further, Normal Duty 2 enables a higher continuous output current before the Inverter overload calculation is started.

Inverters in Protection Class IP00 and IP20 / NEMA 1 and Normal Duty 1

In Normal Duty 1 the default carrier frequency depends on the Inverter capacity. With the default setting the overload capability is 120% of the rated output current for 1 minute. If the carrier frequency is set to a higher value, the overload capability is reduced as shown in *Fig 6.1*.

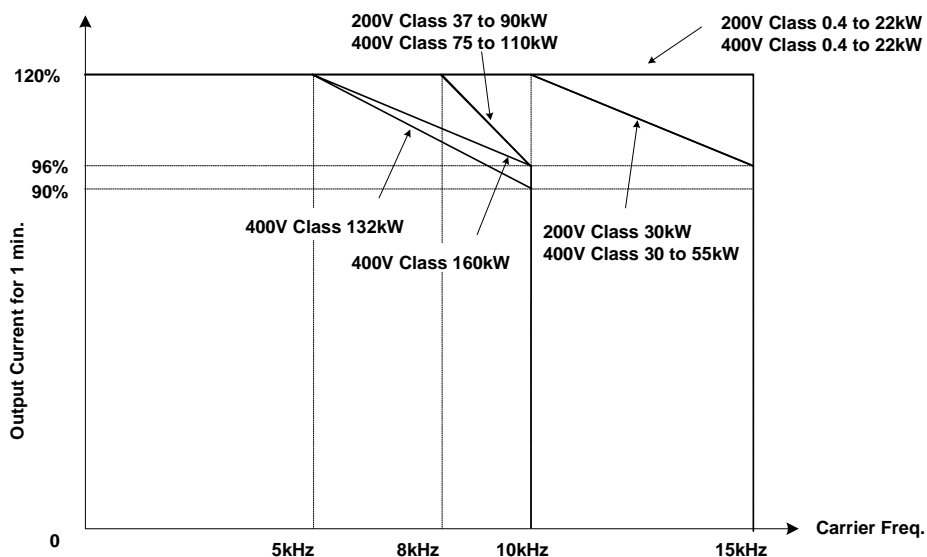

Fig 6.1 Overload Capability depending on Carrier Frequency (IP00 and IP20 / NEMA 1) in Normal Duty 1

Inverters in Protection Class IP00 and IP20 / NEMA 1 and Normal Duty 2

In the Normal Duty 2 mode the maximum carrier frequency is decreased compared to the Normal Duty 1 mode but the short term overload capability is increased. No further increase of the carrier frequency is possible. Refer to *Fig 6.2* for the overload capability of both modes and to *page 5-47, Factory Settings that Change with the Inverter Capacity (o2-04)* for the carrier frequency default settings in Normal Duty 2

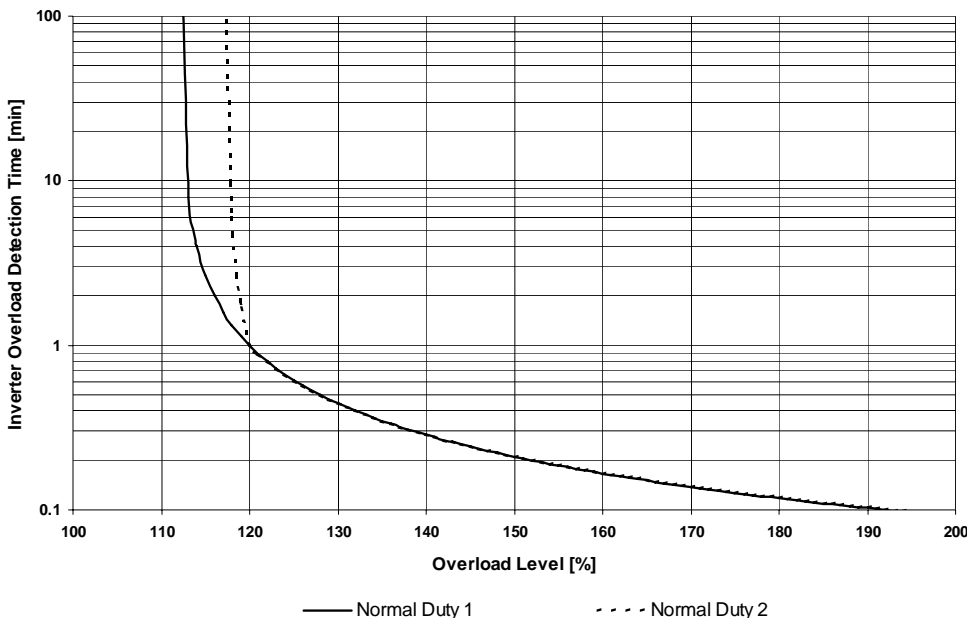

Fig 6.2 Normal Duty 1 and 2 Inverter Overload Detection Curve

Inverters in Protection Class IP54

The default carrier frequency setting is 5kHz for all Inverters in protection class IP54. If the carrier frequency is set to a higher value than the factory setting, the overload capability is reduced as shown in *Fig 6.3*. For IP54 Inverters the setting Heavy Duty 2 is not available.

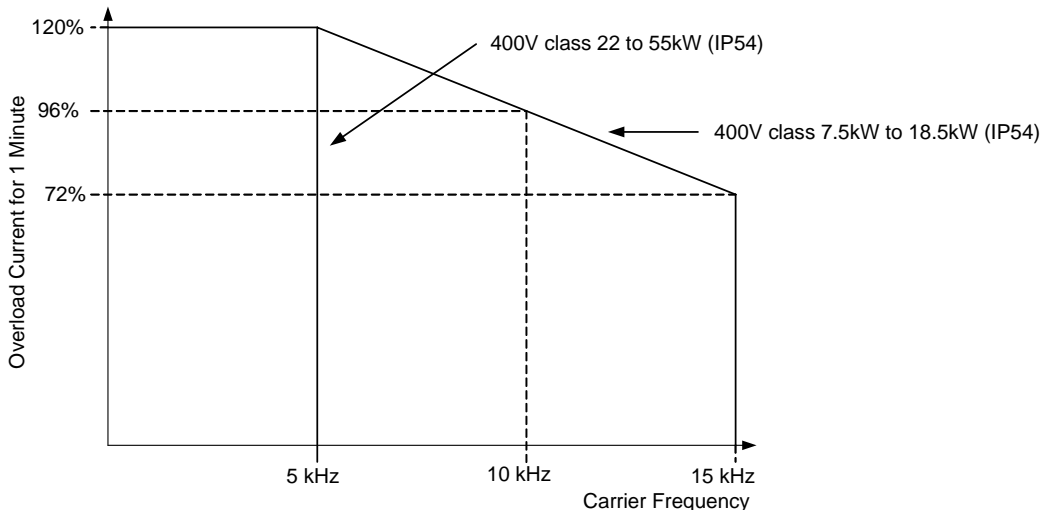

Fig 6.3 Overload Capability depending on Carrier Frequency (IP54)

■ Setting Precautions

Carrier Frequency Selection

When selecting the carrier frequency, observe the following precautions:

- If the wiring distance between Inverter and motor is long: Set the carrier frequency low. (Use the following values as guidelines.

Wiring Length	50 m or less	100 m or less	Over 100 m
C6-02 (carrier frequency) setting	0 to 6 (15 kHz)	0 to 4 (10 kHz)	0 to 2 (5 kHz)

- If speed and torque oscillate at low speeds: Decrease the carrier frequency.
- If Inverter noise is affecting peripheral devices: Decrease the carrier frequency.
- If leakage current from the Inverter is large: Decrease the carrier frequency.
- If metallic noise from the motor is large: Increase the carrier frequency.
- The carrier frequency can be set to vary depending on the output frequency as shown in the following diagram, by setting C6-03 (Carrier Frequency Upper Limit), C6-04 (Carrier Frequency Lower Limit), and C6-05 (Carrier Frequency Proportional Gain).

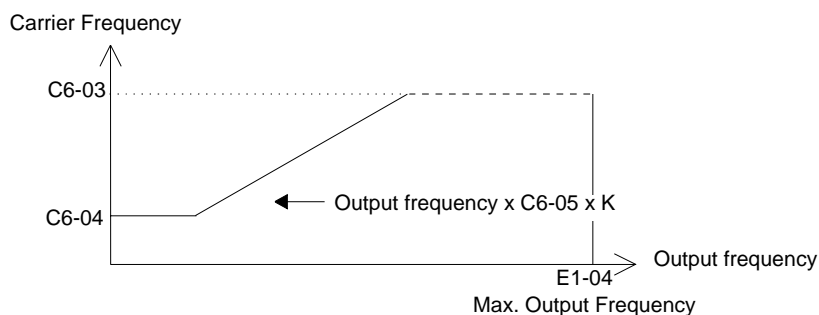

Fig 6.4 Carrier Frequency Gain

* K is the coefficient determined by the set value in C6-03.
 C6-03 ≥ 10.0 kHz: K=3
 10.0 kHz > C6-03 ≥ 5.0 kHz: K=2
 5.0 kHz > C6-03: K=1

- To fix the carrier frequency to any desired value, set C6-03 and C6-04 to the same value, or set C6-05 to 0.

An OPE11 (Data setting error) will occur in the following cases:

- If Carrier Frequency Proportional Gain (C6-05) > 6 and C6-03 < C6-04
- If C6-02 is set from 7 to E.

Frequency Reference

This section explains how to input the frequency reference.

◆ Selecting the Frequency Reference Source

Set parameter b1-01 to select the frequency reference source.

■ Related Parameters

Parameter Number	Name	Setting Range	Factory Setting	Change during Operation	Access Level
b1-01	Reference selection	0 to 3	1	No	Q

■ Input the Frequency Reference from the Digital Operator

When b1-01 is set to 0, the frequency reference can be input from the Digital Operator.

For details on setting the frequency reference, refer to [Chapter 3, Digital Operator and Modes](#)



Fig 6.5 Frequency Setting Display with LED and LCD Digital Operator

■ Inputting the Frequency Reference Using Voltage (Analog Setting)

When b1-01 is set to 1, the frequency reference can be input from the control circuit terminal A1 (voltage input), or control circuit terminal A2 (voltage or current input).

Inputting Master Speed Frequency Reference Only

If inputting the master speed frequency reference only, input the voltage reference to control circuit terminal A1.

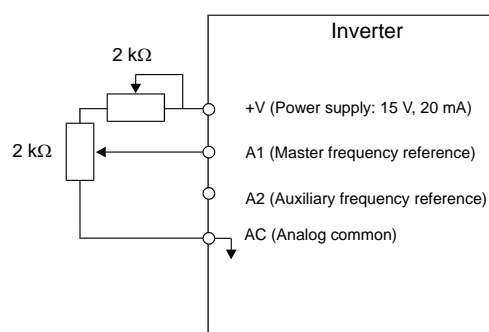

Fig 6.6 Master Speed Frequency Reference Input

2-Step Switching: Master/Auxiliary

If 2-step switching between master and auxiliary speed frequencies is performed, input the master speed frequency reference to control circuit terminal A1, and input the auxiliary speed frequency reference to A2.

When terminal S3 (multi-step speed command 1) is OFF, terminal A1 input (master speed frequency reference) will be the Inverter frequency reference, and when terminal S3 is ON, terminal A2 input (auxiliary speed frequency reference) will be the Inverter frequency reference.

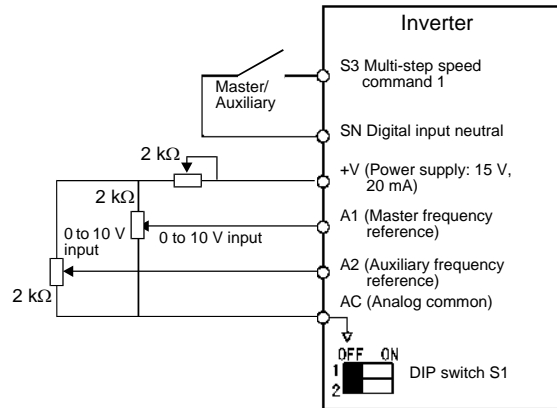

Fig 6.7 Master/Auxiliary Frequency Reference Input

Setting Precautions

When inputting a voltage signal to terminal A2, turn OFF pin 2 on DIP switch S1 to switch to voltage input (factory setting is ON).

■ Inputting Frequency Reference Using Current

When b1-01 is set to 1, the frequency reference can be input from control circuit terminal A2. Input the current (4 to 20 mA) in control circuit terminal A2.

When H3-09 (Multi-Function analog input terminal A2 function selection) is set to 0 (factory setting) the input on A2 is added to A1.

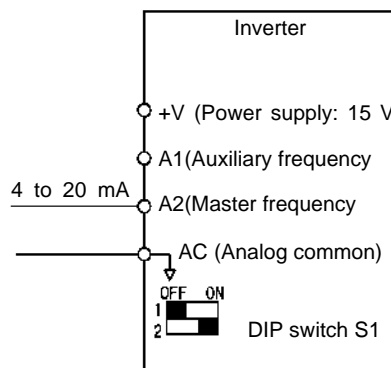

Fig 6.8 Frequency Reference Using Current

Setting Precautions

- When inputting a current signal to terminal A2, turn ON pin 2 on DIP switch S1 (factory setting: ON).
- If using terminal A2 to input the master speed reference and terminal A1 to input the auxiliary frequency reference, set H3-13 (Terminal A1/A2 Switching) to 1.

◆ Using Multi-Step Speed Operation

With Varispeed E7 series Inverters the speed can be changed in a maximum of 5 steps, using 4 multi-step frequency references and one jog frequency reference.

The following example of a multi-function input terminal function shows a 5-step operation using multi-step references 1 and 2 and jog frequency selection functions.

■ Related Parameters

To switch frequency references, set multi-step references 1 and 2 and the jog reference selection in the multi-function digital inputs.

Multi-function Digital Inputs (H1-01 to H1-04)

Terminal	Parameter Number	Set Value	Details
S5	H1-03	3	Multi-step speed command 1 (Also used for master speed/auxiliary speed switching when multi-function analog input H3-09 is set to 2 (auxiliary frequency reference).)
S6	H1-04	4	Multi-step speed command 2
S7	H1-05	6	Jog frequency selection (given priority over multi-step speed command)

Combining Multi-Step Speed References and Multi-Function Digital Inputs

The frequency reference can be changed by combining the ON/OFF status of S4 to S6 (multi-function digital input terminals). The following table shows the possible combinations.

Speed	Terminal S5	Terminal S6	Terminal S7	Selected Frequency
	Multi-step Speed Command 1	Multi-step Speed Command 2	Jog Frequency Selection	
1	OFF	OFF	OFF	Frequency reference 1, d1-01, master speed frequency
2	ON	OFF	OFF	Frequency reference 2, d1-02, auxiliary frequency
3	OFF	ON	OFF	Frequency reference 3, d1-03
4	ON	ON	OFF	Frequency reference 4, d1-04
5	–	–	ON ^{*1}	Jog frequency d1-17

*1. Terminal S6's jog frequency selection is given priority over multi-step speed commands.

Setting Precautions

When setting analog inputs to step 1 and step 2, observe the following precautions.

- When setting terminal A1's analog input to step 1 set b1-01 to 1, when setting d1-01 (Frequency Reference 1) to step 1 set b1-01 to 0.
- When setting terminal A2's analog input to step 2 set H3-09 to 2 (auxiliary frequency reference). When setting d1-02 (Frequency Reference 2) to step 2 set H3-09 to 1F (do not use analog inputs).

■ Connection Example and Time Chart

The following diagram shows a time chart and control circuit terminal connection example during a 9-step operation.

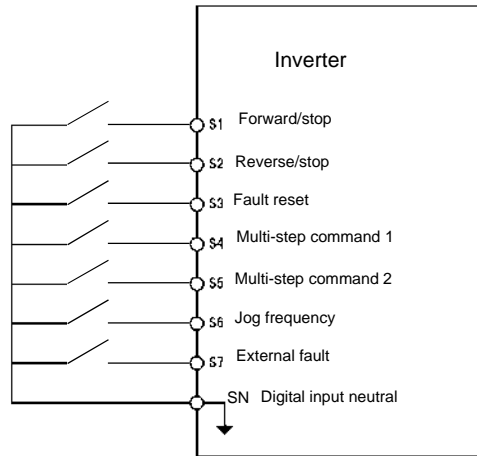

Fig 6.9 Control Circuit Terminal During 5-step Operation

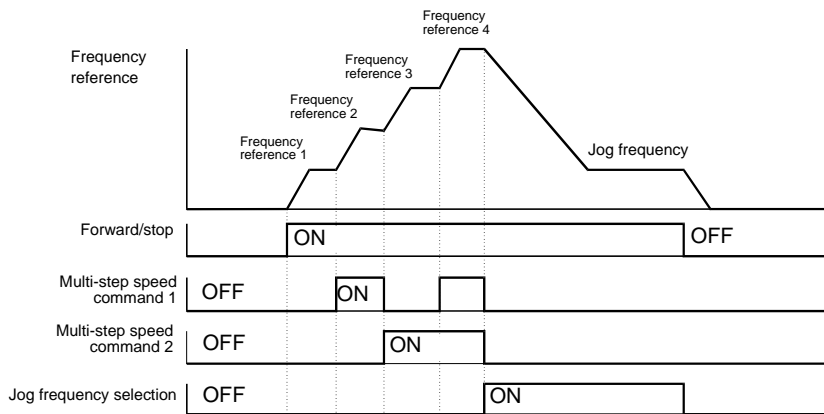

Fig 6.10 Multi-step speed command/Jog Frequency Selection Time Chart

Note:

- The multifunction input setting “Jog Frequency 2” (69) can be used for jog frequency selection when a 3-wire control is used for the control circuit. If it is selected while the inverter is initialized to 2-wire control an OPE03 alarm will be displayed.

Run Command

This section explains input methods for the run command.

◆ Selecting the Run Command Source

Set parameter b1-02 to select the source for the run command.

■ Related Parameters

Parameter Number	Name	Setting Range	Factory Setting	Change during Operation	Access Level
b1-02	Operation method selection	0 to 3	1	No	Q

■ Performing Operations Using a Digital Operator

When b1-02 is set to 0, the Inverter can be operated using the Digital Operator keys (RUN, STOP, and FWD/REV). For details on the Digital Operator, refer to [Chapter 3, Digital Operator and Modes](#).

■ Performing Operations Using Control Circuit Terminals

When b1-02 is set to 1, Inverter operation can be performed using the control circuit terminals.

Performing Operations Using a 2-wire Control

The factory setting is set to a 2-wire control. When control circuit terminal S1 is set to ON, forward operation will be performed, and when S1 is turned OFF, the Inverter will stop. In the same way, when control circuit terminal S2 is set to ON, reverse operation will be performed, and when S2 is turned OFF, the Inverter will stop.

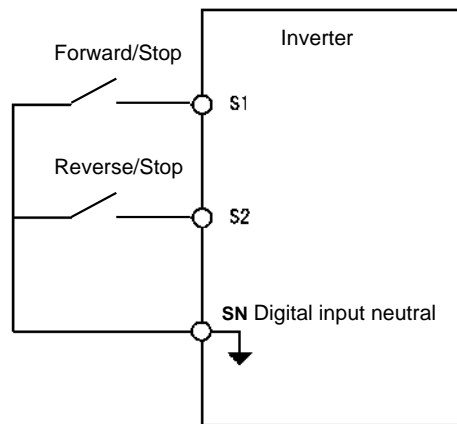

Fig 6.11 2-Wire Control Wiring Example with Positive Logic

Performing Operations Using 3-Wire Control

When any parameter from H1-01 to H1-05 (multi-function digital input terminals S3 to S7) is set to 0, terminals S1 and S2 are used for a 3-wire control, and the multi-function input terminal that has been set to 0 works as a forward/reverse selection command terminal.

When the Inverter is initialized for 3-wire control with A1-03, multi-function input 3 becomes the input terminal for the forward/reverse run command.

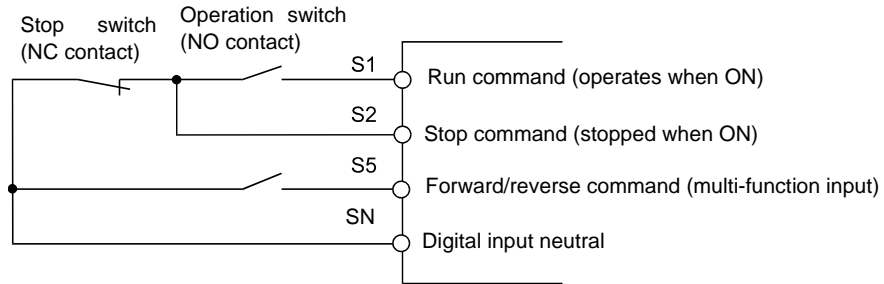

Fig 6.12 3-Wire Control Wiring Example

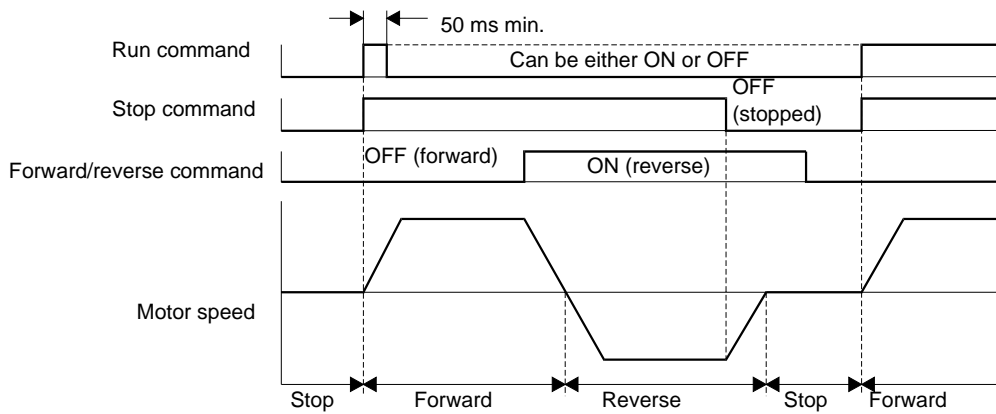

Fig 6.13 Three-wire Control Time Chart



NOTE

Use a control circuit that turns ON terminal S1 for 50 ms or longer for the run command. This will make the run command self-holding in the Inverter.

Stopping Methods

This section explains methods of stopping the Inverter.

◆ Selecting the Stopping Method when a Stop Command is Input

There are four methods of stopping the Inverter when a stop command is input:

- Deceleration to stop
- Coast to stop
- DC braking stop
- Coast to stop with timer

Set parameter b1-03 to select the Inverter stopping method.

■ Related Parameters

Parameter Number	Name	Setting Range	Factory Setting	Change during Operation	Access Level
b1-03	Stopping method selection	0 to 3	0	No	Q
b2-01	Zero speed level (DC injection braking starting frequency)	0.0 to 10.0	0.5 Hz	No	A
b2-02	DC injection braking current	0 to 100	50%	No	A
b2-04	DC injection braking time at stop	0.00 to 10.00	0.50 sec.	No	A

Deceleration to Stop

If the stop command is input (the run command is turned OFF) when b1-03 is set to 0, the motor decelerates to stop according to the deceleration time that has been set. (Factory setting: C1-02 (Deceleration Time 1)).

If the output frequency when decelerating to stop falls below b2-01, the DC injection brake will be applied using the DC current set in b2-02 for the time set in b2-04.

For deceleration time settings, refer to [page 6-15, Setting Acceleration and Deceleration Times](#).

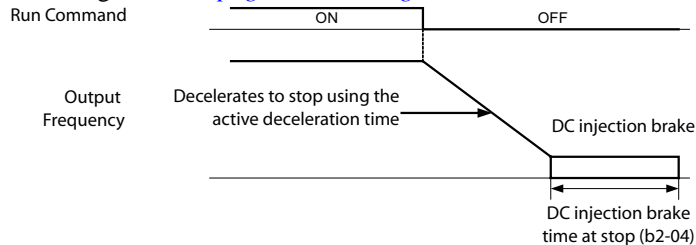

Fig 6.14 Deceleration to Stop

Coast to Stop

If the stop command is input (i.e., the run command is turned OFF) when b1-03 is set to 1, the Inverter output voltage is switched off. The motor coasts to stop.

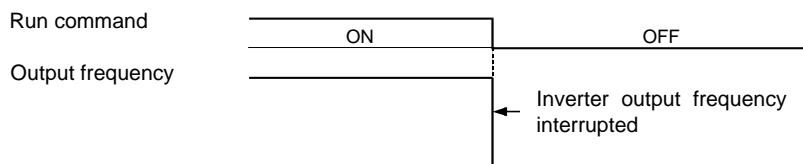

Fig 6.15 Coast to Stop



NOTE

After the stop command is input, run commands are ignored until the Minimum Baseblock Time (L2-03) has elapsed.

DC Braking Stop

After the stop command is input and the minimum baseblock time (L2-03) has elapsed, DC injection will be applied to the motor. The applied DC injection current is programmed in parameter b2-02. The DC injection brake time depends on the set value of b2-04 and on the output frequency at the moment the stop command is input. If the output frequency was higher than 10% of the maximum output frequency (E1-04) the DC injection time is lengthened like shown in the figure below.

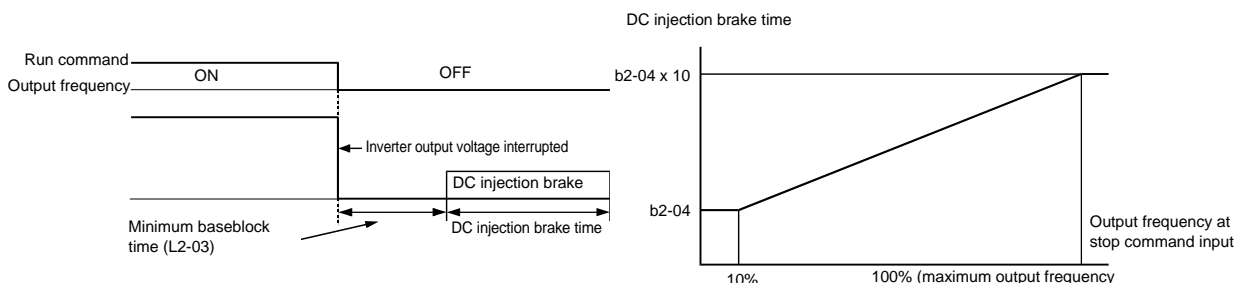

Fig 6.16 DC Injection Braking Stop



NOTE

Lengthen the Minimum Baseblock Time (L2-03) when an overcurrent (OC) occurs during stopping.

■ Coast to Stop with Timer

If the stop command is input (i.e., the run command is turned OFF) when b1-03 is set to 3, the Inverter output is switched off so that the motor coasts to stop. After the stop command is input, run commands are ignored until the time T has elapsed. The time T depends on the output frequency when the stop command is input and on the deceleration time.

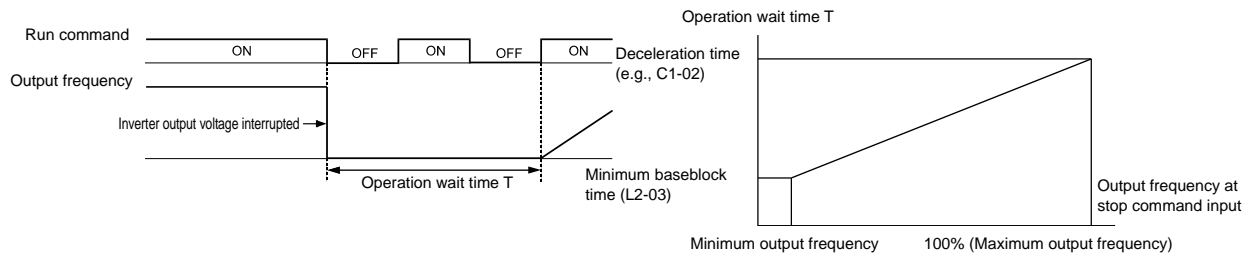

Fig 6.17 Coast to Stop with Timer

◆ Using the DC Injection Brake

Set parameter b2-03 to apply DC injection to the motor, before it starts to accelerate. Applying DC injection at start will stop the motor before starting if it was coasting through inertia or wind mill effect.

Set b2-03 to 0 to disable the DC injection brake at start.

Set parameter b2-04 to apply a DC injection brake to the motor at stopping. It prevents the motor from coasting when it would not be stopped completely using the normal deceleration. This can occur if the inertia is very high. The DC injection brake can be disabled by setting b2-04 to 0.

Set the DC injection brake current using b2-02.

■ Related Parameters

Parameter Number	Name	Setting Range	Factory Setting	Change during Operation	Access Level
b2-01	DC injection braking starting frequency	0.0 to 10.0	0.5 Hz	No	A
b2-02	DC injection braking current	0 to 100	50%	No	A
b2-03	DC injection braking time at start	0.00 to 10.00	0.00 sec.	No	A
b2-04	DC injection braking time at stop	0.00 to 10.0	0.50 sec.	No	A

◆ Using an Emergency Stop

Set a multi-function input terminal (H1-01 to H1-05) to 15 or 17 (emergency stop) to decelerate to stop using the deceleration time set in C1-09. If inputting the emergency stop with an NO contact, use setting 15, and if inputting the emergency stop with an NC contact, use setting 17.

After the emergency stop command has been input, operation cannot be restarted until the Inverter has stopped. To cancel the emergency stop, turn OFF the run command and emergency stop command.

■ Related parameters

Parameter Number	Name	Setting Range	Factory Setting	Change during Operation	Access Level
C1-09	Emergency stop time	0.0 to 6000.0	10.0 sec.	No	A

Acceleration and Deceleration Characteristics

This section explains the acceleration and deceleration characteristics of the Inverter.

◆ Setting Acceleration and Deceleration Times

Acceleration time indicates the time to increase the output frequency from 0% to 100% of the maximum output frequency (E1-04). Deceleration time indicates the time to decrease the output frequency from 100% to 0% of (E1-04). The accel./decel. times 1 are used with the factory setting, the accel./decel. times 2 can be selected using a multifunction input.

■ Related Parameters

Parameter Number	Name	Setting Range	Factory Setting	Change during Operation	Access Level
C1-01	Acceleration time 1	0.0 to 6000.0	10.0 sec.	Yes	Q
C1-02	Deceleration time 1			Yes	Q
C1-03	Acceleration time 2			Yes	A
C1-04	Deceleration time 2			Yes	A
C1-11	Acceleration/deceleration time switching frequency	0.0 to 200.0	0.0 Hz	No	A
C2-01	S-curve characteristic time at acceleration start	0.00 to 2.50	0.20 sec.	No	A
C2-02	S-curve characteristic time at acceleration end	0.00 to 2.50	0.20 sec.	No	A

■ Switching Acceleration and Deceleration Time Using Multi-Function Input Terminal Commands

Two different acceleration times and deceleration times can be set. When one multi-function input terminal (H1-□□) is set to 7 (acceleration/deceleration time selection 1), the acceleration/deceleration time can even be switched during operation by changing the ON/OFF status of this terminal.

The following table shows the acceleration/deceleration time switching combinations.

Acceleration/Deceleration Time Selection 1 Terminal	Acceleration Time	Deceleration Time
OFF	C1-01	C1-02
ON	C1-03	C1-04

■ Switching Acceleration and Deceleration Time Automatically

Use this setting when the acceleration/deceleration time should be switched automatically depending on the output frequency.

When the output frequency reaches the set value in C1-11, the Inverter switches the acceleration/deceleration time automatically as shown in the following diagram.

Set C1-11 to a value other than 0.0 Hz. If C1-11 is set to 0.0 Hz, the function will be disabled.

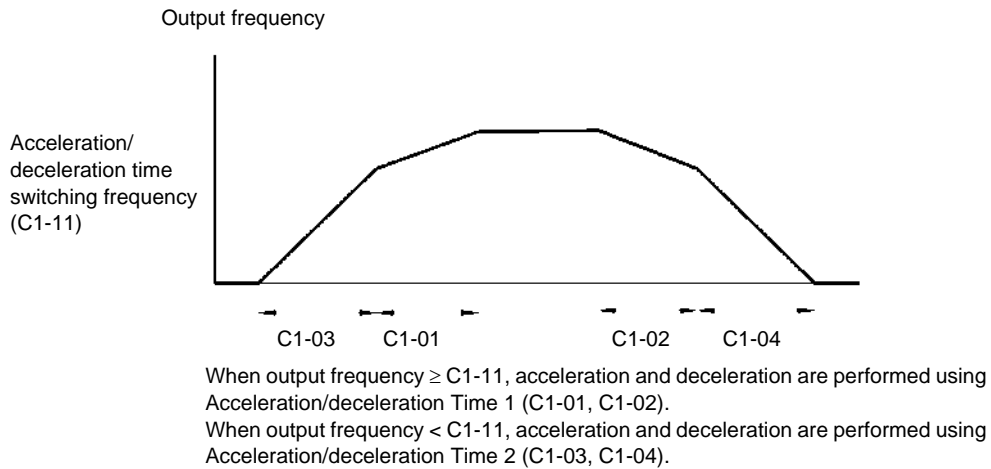

Fig 6.18 Acceleration/deceleration Time Switching Frequency

■ Entering S-curve Characteristics in the Acceleration and Deceleration Time

By performing acceleration and deceleration using an S-curve pattern, shock at start and stop of the machine can be reduced

Two S-curve characteristic times can be set: At acceleration start and at acceleration end. For deceleration start and end the S-curve times are fixed to 0.2 sec.



When S-curve is set, calculate acceleration/deceleration time as follows:

$$\text{Accel. Time} = \frac{C2-01 + C2-02}{2} + C1-01/03$$

$$\text{Decel. Time} = 0.2 \text{ sec} + C1-02/04$$

Setting Example

The S-curve characteristic when switching operation (forward/reverse) is shown in the following diagram.

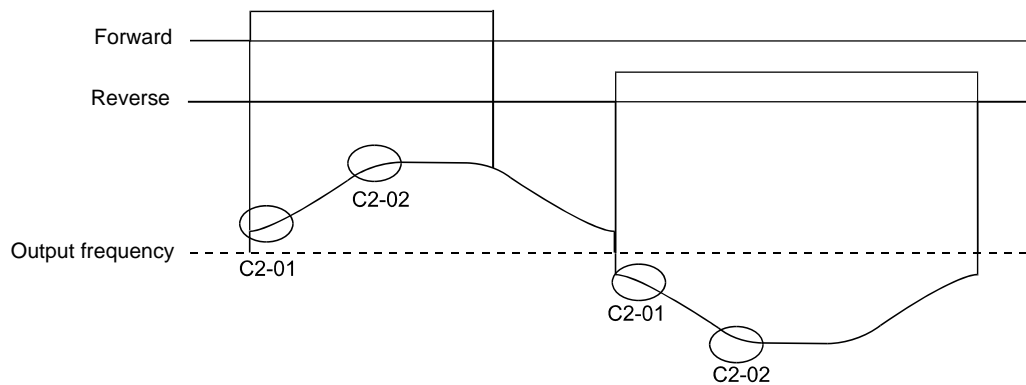

Fig 6.19 S-curve Characteristic during Operation Switching

◆ Preventing the Motor from Stalling During Acceleration (Stall Prevention During Acceleration Function)

The Stall Prevention During Acceleration function prevents the motor from stalling if a heavy load is applied to the motor, or sudden rapid acceleration is performed.

If L3-01 is set to 1 (enabled) and the Inverter output current reaches 85 % of the set value in L3-02, the acceleration rate will begin to slow down. When L3-02 is exceeded, the acceleration will stop.

If L3-01 is set to 2 (optimum adjustment), the motor accelerates so that the current is held at a level of 50 % of the inverter rated current. With this setting, the acceleration time setting is ignored.

■ Related Parameters

Parameter Number	Name	Setting Range	Factory Setting	Change during Operation	Access Level
L3-01	Stall prevention selection during acceleration	0 to 2	1	No	A
L3-02	Stall prevention level during acceleration	0 to 200	120%	No	A

■ Time Chart

The following figure shows the frequency characteristics when L3-01 is set to 1.

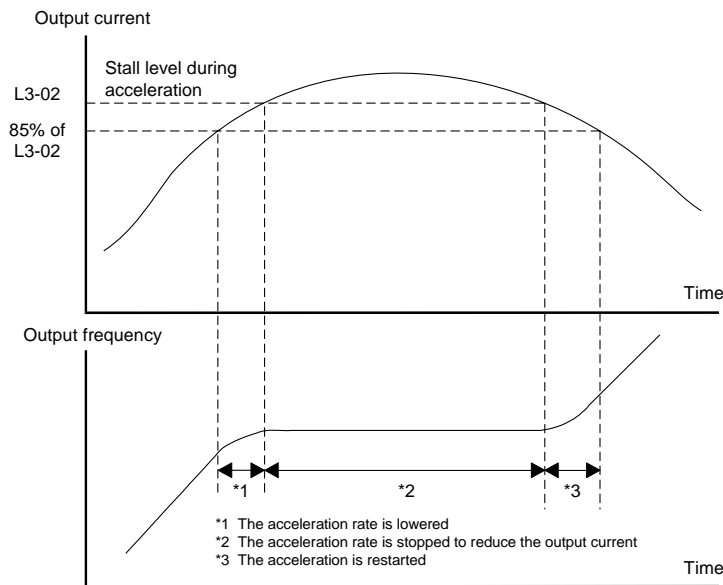

Fig 6.20 Time Chart for Stall Prevention During Acceleration

■ Setting Precautions

- If the motor capacity is small compared to the Inverter capacity or if the inverter is operated using the factory settings and the motor stalls, lower the set value of L3-02.
- If using the motor in the field weakening range, L3-02 will be automatically lowered to prevent stalling. It will be reduced to a fixed value of 50 % of the inverter rated current.
- Set the parameters as a percentage taking the inverter rated current to be 100%.

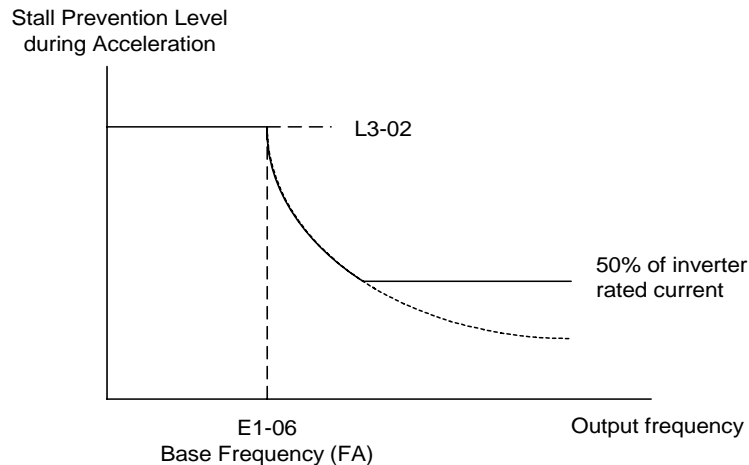

Fig 6.21 Stall Prevention Level and Limit During Acceleration

◆ Stall Prevention During Deceleration Function

This function automatically lengthens the deceleration time with respect to the DC-bus voltage to avoid over-voltage tripping.

■ Related Parameters

Parameter Number	Name	Setting Range	Factory Setting	Change during Operation	Access Level
E1-01	Input voltage setting	155 to 255*1	200 VDC*1	No	Q
L3-04	Stall prevention selection during deceleration function selection	0 to 2	1	No	A

*1. Value for 200 V class Inverters are shown. For a 400 V class inverter the values have to be doubled.

■ Setting the Stall Prevention Selection During Deceleration (L3-04)

There are four different settings selectable for L3-04.

L3-04=0: This setting disables the stall prevention function during deceleration. The motor will be decelerated using the time set in C1-02 (C1-04). If the load inertia is very high and an OV fault occurs during deceleration a braking option has to be used or the deceleration time has to be lengthened.

L3-04=1: This setting enables the stall prevention during deceleration. The inverter tries to decelerate within the set deceleration time. It also observes the DC bus voltage. If the DC bus voltage reaches the stall prevention level the deceleration is stopped and the output frequency is held. When the DC bus voltage falls below the stall prevention level the deceleration will be continued.

L3-04=2: This setting enables the stall prevention during deceleration. The deceleration time set as C1-□□ is taken as reference. The function automatically tries to optimize the deceleration time by observing the DC bus voltage and shortening the deceleration time. The function does not lengthen the deceleration time, i.e. if C1-□□ is set too short OV may occur.

■ Setting Example

An example of stall prevention during deceleration when L3-04 is set to 1 is shown below.

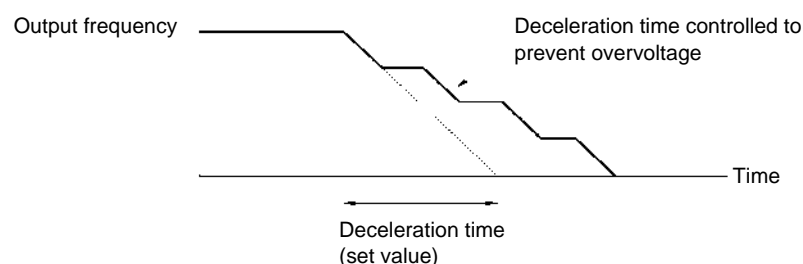

Fig 6.22 Stall Prevention During Deceleration Operation

■ Setting Precautions

- The stall prevention level during deceleration differs depending on the inverter rated voltage and input voltage. Refer to the following table for details.

Inverter Rated/Input Voltage		Stall Prevention Level during Deceleration
200 V class		380 VDC
400 V class	$E1-01 \geq 400 \text{ V}$	760 VDC
	$E1-01 < 400 \text{ V}$	660 VDC

- When using a braking option, be sure to set parameter L3-04 to 0.

Adjusting Frequency References

◆ Adjusting Analog Frequency References

The analog reference values can be adjusted using the gain and bias functions for the analog inputs.

■ Related Parameters

Parameter Number	Name	Setting Range	Factory Setting	Change during Operation	Access Level
H3-02	Frequency reference terminal A1 input gain	0.0 to 1000.0	100.0%	Yes	A
H3-03	Frequency reference terminal A1 input bias	-100.0 to +100.0	0.0%	Yes	A
H3-08	Multi-function analog A2 signal level selection	0, 2, 3	2 ^{*1}	No	A ^{*2}
H3-09	Multi-function analog A2 function selection	0 to 16	0	No	A ^{*2}
H3-10	Multi-function analog A2 input gain	0.0 to 1000.0	100.0%	Yes	A
H3-11	Multi-function analog A2 input bias	-100.0 to +100.0	0.0%	Yes	A
H3-12	Analog input filter time constant	0.00 to 2.00	0.30 sec.	No	A
H3-13	Terminal A1/A2 switching	0 or 1	0	No	A ^{*2}

*1. The setting is automatically switched to "B" when the PI controller is enabled

*2. Parameter is moved to Quick Programming Mode when PI controller is enabled.

■ Adjusting Analog Frequency Reference Using Parameters

The frequency reference can be input from the control circuit terminals using analog voltage or current signals (analog input A2 only).

The input signal levels can be selected using

- H3-01 for the analog input A1
- H3-08 for the analog input A2

Adjustments to the signals can be made using:

- H3-02 (Gain) and H3-03 (Bias) if analog input A1 is selected to be the frequency reference input
- H3-10 (Gain) and H3-11 (Bias) if analog input A2 is selected to be the frequency reference input

Refer to [Fig 6.23](#) for adjusting the signal using the gain and bias functions.

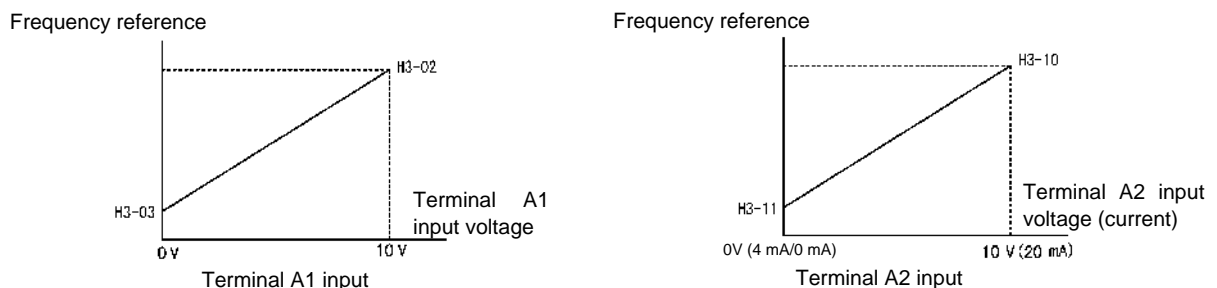

Fig 6.23 Terminals A1 and A2 Inputs

■ Adjusting Frequency Bias Using an Analog Input

Frequency Bias (Setting: 0)

When parameter H3-09 is set to 0 (Frequency Bias), the frequency equivalent to the terminal A2 input voltage is added to the analog master frequency input at terminal A1 as a bias.

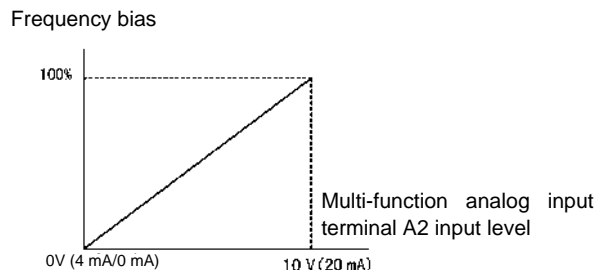

Fig 6.24 Frequency Bias Adjustment (Terminal A2 Input)

For example, if H3-02 is 100%, H3-03 is 0%, and terminal A2 is set to 1 V, the frequency reference when 0 V is input to A1 will be 10% of the maximum output frequency (E1-04).

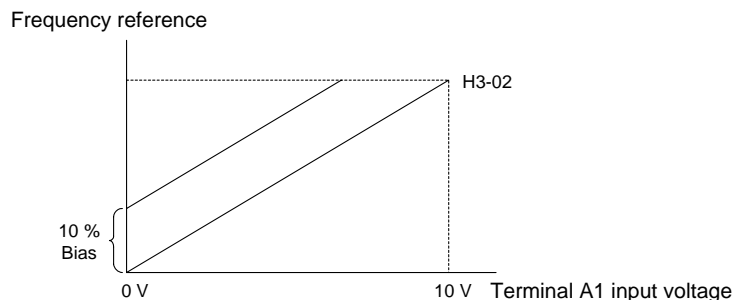

Fig 6.25 Example Operation for Frequency Bias via Terminal A2

Frequency Bias 2 (Setting: D)

In contrary to the frequency bias function (H3-09=0) the frequency bias 2 function adds the analog bias value to any master frequency value, either from the analog input, MEMOBUS communication or option boards. The bias value is not applied to multi-step speed references using the d1-□□ parameters.

Setting Precautions

- When the PI controller is enabled the function setting for analog input A2 is automatically switched to PI feedback.
- If the Master Frequency Reference has to be input with a current signal (0/4 to 20 mA) the functionality of analog input A1 and A2 can be exchanged using parameter H3-13.
- If the analog input A2 is used with a current signal ensure the proper setting of switch S1. Refer to [page 2-32, Switch S1 - Standard Terminal Board](#).
- In case a voltage reference signal is noisy a analog input filter time can be adjusted. By default a filter time of 0.3 sec. is set.

◆ Jump Frequency Function (Operation Avoiding Resonance)

- This function allows the prohibition or “jumping” of certain frequencies within the Inverter’s output frequency range so that the motor can operate without resonant oscillations caused by some machine systems.
- It can also be used for deadband control.

■ Related Parameters

Parameter Number	Name	Setting Range	Factory Setting	Change during Operation	Access Level
d3-01	Jump frequency 1	0.0 to 200.0	0.0 Hz	No	A
d3-02	Jump frequency 2		0.0 Hz	No	A
d3-03	Jump frequency 3		0.0 Hz	No	A
d3-04	Jump frequency width	0.0 to 20.0	1.0 Hz	No	A

The relationship between the output frequency and the jump frequency reference is as follows:

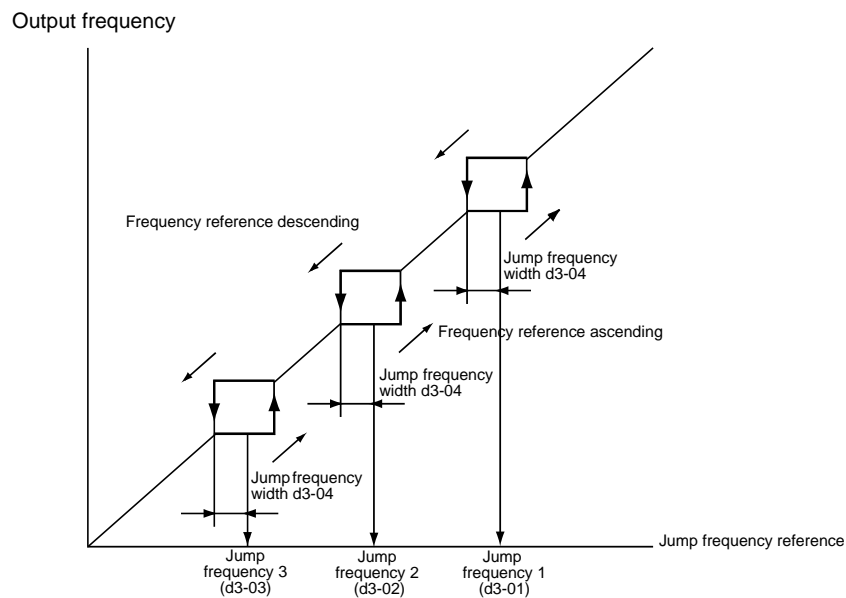

Fig 6.26 Jump Frequency

■ Setting Precautions

- Set the jump frequencies according to the following formula: $d3-01 \geq d3-02 \geq d3-03$.
- When parameters d3-01 to d3-03 are set to 0 Hz, the jump frequency function is disabled.

Speed Limit (Frequency Reference Limit Function)

This section explains how to limit the motor speed.

◆ Limiting Maximum Output Frequency

If the motor should not rotate above a given frequency, use parameter d2-01.

Set the upper limit value of the frequency reference as a percentage, taking E1-04 (Maximum Output Frequency) to be 100%.

■ Related Parameters

Parameter Number	Name	Setting Range	Factory Setting	Change during Operation	Access Level
d2-01	Frequency reference upper limit	0.0 to 110.0	100.0%	No	A

◆ Limiting Minimum Frequency

If the motor should not rotate below a given frequency, use parameters d2-02 or d2-03.

There are two methods of limiting the minimum frequency, as follows:

- Adjust the minimum level for all frequencies.
- Adjust the minimum level for the master speed frequency (i.e., the lower levels of the jog frequency, multi-step speed frequency, and auxiliary frequency will not be adjusted).

■ Related Parameters

Parameter Number	Name	Setting Range	Factory Setting	Change during Operation	Access Level
d2-02	Frequency reference lower limit	0.0 to 110.0	0.0%	No	A
d2-03	Master speed reference lower limit	0.0 to 110.0	0.0%	No	A

Frequency Detection

◆ Speed Agreement Function

There are four different types of frequency detection methods available. The digital multifunction outputs M1 to M4 can be programmed for this function and can be used to indicate a frequency detection or agreement to any external equipment.

■ Related Parameters

Parameter Number	Name	Setting Range	Factory Setting	Change during Operation	Access Level
L4-01	Speed agreement detection level	0.0 to 200.0	0.0 Hz	No	A
L4-02	Speed agreement detection width	0.0 to 20.0	2.0 Hz	No	A

- With L4-01 an absolute speed agreement level is set, i.e. a speed agreement is detected in both directions (FWD and REV).

■ Multifunction Output Settings: H2-01 to H2-02 (M1 – M4 function selection)

The table below shows the necessary H2-01 and H2-02 parameter setting for each of the speed agreement functions.

Set Value	Function
2	$f_{\text{ref}} = f_{\text{out}}$ Agree
3	$f_{\text{out}} = f_{\text{set}}$ Agree
4	Frequency detection 1
5	Frequency detection 2

Time Charts

The following table shows the time charts for each of the speed agreement functions.

Related parameter	L4-01: Speed Agree Level L4-02: Speed Agree Width
$f_{ref} = f_{out}$ Agree	<p>$f_{ref} = f_{out}$ Agree</p> <p>Multi-function output setting = 2)</p>
$f_{out} = f_{set}$ Agree	<p>$f_{out} = f_{set}$ Agree (ON at the following conditions during frequency agree)</p> <p>Multi-function output setting = 3)</p>
Frequency Detection	<p>Frequency (FOUT) Detection 1 (L4-01 > Output frequency)</p> <p>Multi-function output setting = 4)</p>
	<p>Frequency (FOUT) Detection 2 (L4-01 < Output frequency)</p> <p>Multi-function output setting = 5)</p>

Improved Operating Performance

This section explains functions for improving motor operating efficiency.

◆ Torque Compensation for Sufficient Torque at Start and Low-speed Operation

The torque compensation function detects a rising motor load, and increases the output torque.

The inverter calculates the motor primary loss voltage and adjusts the output voltage (V) to compensate insufficient torque at startup and during low-speed operation. The compensation voltage is calculated as follows:
Motor primary voltage loss × parameter C4-01.

■ Related Parameters

Parameter Number	Name	Setting Range	Factory Setting	Change during Operation	Access Level
C4-01	Torque compensation gain	0.00 to 2.50	1.00	Yes	A
C4-02	Torque compensation delay time constant	0 to 10000	200 msec	No	A

■ Adjusting Torque Compensation Gain (C4-01)

Normally, there is no need to change this setting.

Adjust the torque compensation gain under the following circumstances.

- If the cable is very long, increase the set value.
- If the motor capacity is smaller than the Inverter capacity (max. applicable motor capacity), increase the set value.
- If the motor is vibrating, reduce the set value.

Adjust this parameter so that the output current during low-speed rotation does not exceed the Inverter rated output current range.

■ Adjusting the Torque Compensation Primary Delay Time Constant (C4-02)

Set the torque compensation function primary delay in milliseconds.

Normally, there is no need to change this setting. Adjust the parameter under the following circumstances:

- If the motor is vibrating, increase the set value.
- If the motor response is low, decrease the set value.

◆ Hunting Prevention Function

The hunting prevention function suppresses hunting when the motor is operating with a light load.

If high response has the priority to vibration suppression this function should be disabled (n1-01 = 0).

■ Related Parameters

Parameter Number	Name	Setting Range	Factory Setting	Change during Operation	Access Level
n1-01	Hunting prevention function selection	0 or 1	1	No	A
n1-02	Hunting prevention gain	0.00 to 2.50	1.00	No	A

■ Adjusting the Hunting Prevention Gain (n1-02)

Normally it is not necessary to change this setting. Adjust the value under the following circumstances:

- If vibrations occur under light load condition increase the setting.
- If the motor stalls reduce the setting.

Machine Protection

◆ Preventing Motor Stalling During Operation

Stall prevention during operation prevents the motor from stalling by automatically lowering the Inverter's output frequency when a transient overload occurs while the motor is operating at a constant speed.

If the Inverter output current continues to exceed the setting in parameter L3-06 for 100 ms or longer, the motor speed is reduced. Set whether to enable or disable the stall prevention using parameter L3-05. Set the according deceleration times using C1-02 (Deceleration time 1) or C1-04 (Deceleration Time 2).

If the Inverter output current reaches the set value in L3-06 – 2%, the motor will accelerate again to the set frequency.

■ Related Parameters

Parameter Number	Name	Setting Range	Factory Setting	Change during Operation	Access Level
L3-05	Stall prevention selection during running function selection	0 to 2	1	No	A
L3-06	Stall prevention level during running	30 to 200	120%	No	A

◆ Load Detection

If an excessive load is applied to the machinery (overload) or the load suddenly drops (loss of load), an alarm signal can be output via one of the output terminal M1-M2 or M3-M4.

To use the load detection function, set B or 17 (overload/loss of load detection NO/NC) in one of the parameter H2-01 and H2-02 (terminals M1-M2 and M3-M4 function selection).

The load detection level is set as a current level taking the inverter rated output current as 100%.

■ Related Parameters

Parameter Number	Name	Setting Range	Factory Setting	Change during Operation	Access Level
L6-01	Torque detection selection	0 to 8	6	No	A
L6-02	Torque detection level	0 to 300	15%	No	A
L6-03	Torque detection time	0.0 to 10.0	10.0 sec.	No	A

Multi-function Output (H2-01 and H2-02)

Set Value	Function
B	Load detection NO (NO contact: Overload or loss of load detected when output is ON)
17	Load detection NC (NC contact: Overload or loss of load detected when output is OFF)

■L6-01 Set Value and Digital Operator Display

The relationship between alarms displayed on the Digital Operator when overload or loss of load is detected and the setting in L6-01 is shown in the following table.

Set Value	Function	Operator	Inverter condition
		Overload/Under-torque Detection 1	
0	Load detection disabled	–	–
1	Overload detection only at speed agree, the operation is continued, a warning is output.	OL3 flashes	Alarm
2	Overload detection continuously during operation, operation continues, a warning is output.	OL3 flashes	Alarm
3	Overload detection only at speed agree, motor coasts to stop, Inverter is in fault condition.	OL3 lights up	Fault
4	Overload detection continuously during operation, motor coasts to stop, Inverter is in fault condition.	OL3 lights up	Fault
5	Loss of load detection only at speed agree, the operation is continued, a warning is output.	LL3 flashes	Alarm
6	Loss of load detection continuously during operation, operation continues, a warning is output.	LL3 flashes	Alarm
7	Loss of load detection only at speed agree, motor coasts to stop, Inverter is in fault condition.	LL3 lights up	Fault
8	Loss of load detection continuously during operation, motor coasts to stop, Inverter is in fault condition.	LL3 lights up	Fault

■Setting Example

The following diagram shows the time chart for overload and loss of load detection.

- Overload Detection

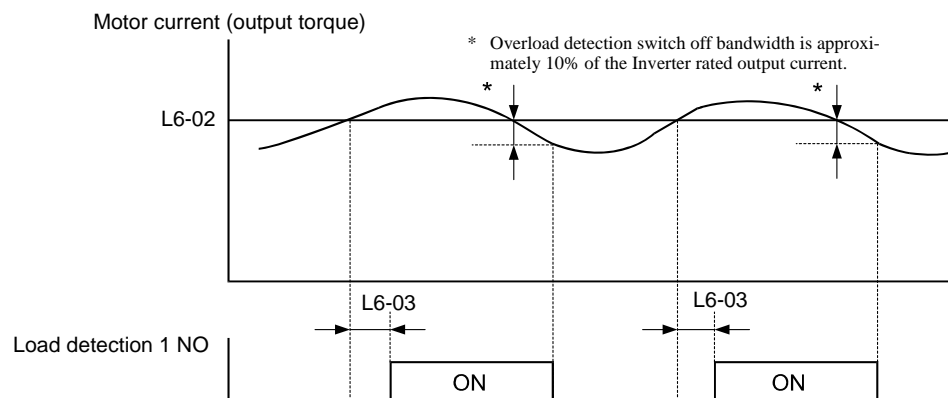

Fig 6.27 Example Operation for Overload Detection

- Loss of Load Detection

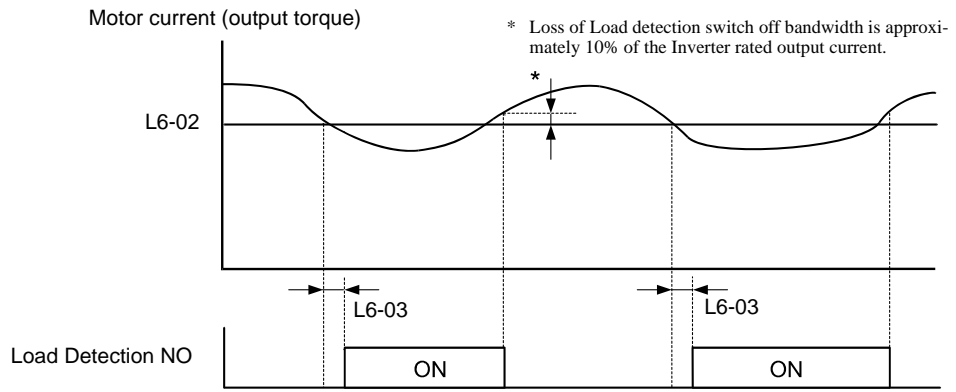

Fig 6.28 Example Operation for Loss of Load Detection

◆ Motor Overload Protection

The motor can be protected from overload using the Inverter's built-in electronic thermal overload relay function (I^2t calculation).

■ Related Parameters

Parameter Number	Name	Setting Range	Factory Setting	Change during Operation	Access Level
E2-01	Motor rated current	0.32 to 6.40 *1	1.90 A *2	No	Q
L1-01	Motor protection selection	0 to 3	1	No	A
L1-02	Motor protection time constant	0.1 to 5.0	1.0 min	No	A

*1. The setting range is 10% to 200% of the Inverter rated output current. The value for a 200 V class Inverter of 0.4kW is given.

*2. The factory setting depends on the Inverter Capacity. The value for a 200 V class Inverter of 0.4 kW is given.

Multi-Function Outputs (H2-01 to H2-02)

Set Value	Function
1F	During motor overload (OL1, including OH3) pre-alarm (ON: 90% or more of the detection level)

■ Setting Motor Rated Current (E2-01)

Set the rated current value on the motor nameplate in parameters E2-01. This set value is the base current for the internal thermal overload calculation.

■ Setting Motor Overload Protection Characteristics (L1-01)

Set the overload protection function in L1-01 according to the application.

Set L1-01 to:

- 0: to disable the thermal motor protection function.
- 1: to enable the thermal motor protection for a fan cooled general purpose motor (self-cooled).
- 2: to enable the thermal motor protection for Inverter motors (forced or externally cooled)
- 3: to enable the thermal motor protection for a special vector motor (externally cooled).

■ Application Precautions

- If a multi-function digital output is programmed to 1F the output will stay switched ON as long as the motor is overloaded. When the motor has been stopped to cool down the output will be switched OFF as soon as the Inverter's I^2t calculation falls below 90% of the detection level.
- The multi-function digital output programmed to 1F will also switch OFF when the Inverter itself is in fault condition. The fault has to be reset manually.

■ Setting Motor Protection Operation Time (L1-02)

Set the motor protection operation time in L1-02.

The motor protection operation time is the time for that the motor can handle a 150% overload when it was running with the rated load before (i.e. operating temperature was reached before applying the 150% overload). Set the motor protection operation time in L1-02. The factory setting is 60 sec.

The following diagram shows an example of the characteristics of the electronic thermal protection operation time (L1-02 = 1.0 min., operation at 50 Hz, general-purpose motor characteristics, when L1-01 is set to 1)

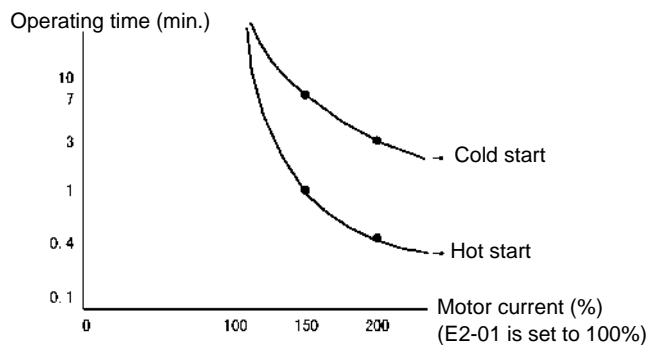

Fig 6.29 Motor Protection Operation Time

■ Setting Precautions

- If multiple motors are connected to one inverter, set parameter L1-01 to 0 (disabled). To protect each of the motors, use a control circuit that switches off the inverter output when one of the motors overheats.
- With applications where the power supply is often turned ON and OFF, there is a risk that the motor cannot be protected even if this parameter has been set to 1 (enabled), because the internally calculated thermal value will be reset after inverter power supply switch off.
- For safe overload tripping, set the value in parameter L1-02 to a low setting.
- When using a general-purpose motor (standard motor), the cooling ability will be lowered by $f^{1/4}$ (frequency). Consequently, a low output frequency may cause motor overload protection (OL1) to occur, even when the output current is below the rated current. If the motor is operated at the rated current at a low frequency, use a special motor which is externally cooled.

■ Setting the Motor Overload Pre-Alarm

To enable the Motor overload pre-alarm enable the motor overload protection function (i.e., L1-01 must be set to 1) and set H2-01 or H2-02 (multi-function output terminals M1-M2 and M3-M4 function selection) to 1F (motor overload OL1 pre-alarm). If the electronic thermal value reaches minimum 90% of the overload detection level, the output terminal that has been set will be turned ON.

■ Application Precautions

With applications where the power supply is often turned ON and OFF, there is a risk that the motor cannot be protected even if this parameter has been set to 1 to 3, because the thermal value will be reset.

◆ Motor Overheat Protection Using PTC Thermistor Inputs

This function provides a motor overheating protection using a thermistor (PTC characteristic – Positive Temperature Coefficient) that is built into the windings of each motor phase.

■ Related Parameters

Parameter Number	Name	Setting Range	Factory Setting	Change during Operation	Access Level
L1-03	Alarm operation selection during motor overheating	0 to 3	3	No	A
L1-04	Motor overheating operation selection	0 to 2	1	No	A
L1-05	Motor temperature input filter time constant	0.00 to 10.00	0.20 sec.	No	A

■ PTC Thermistor Characteristics

The following diagram shows the characteristics of the PTC thermistor temperature to the resistance value. The shown resistance value is for one motor phase. Normally the 3 resistors (1 for each phase) are connected in series

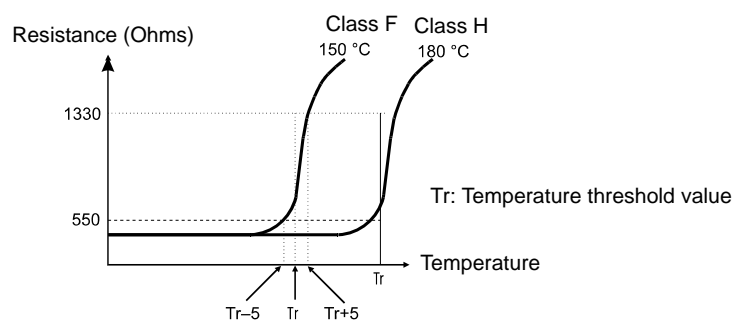

Fig 6.30 PTC Thermistor Temperature-Resistance Value Characteristics

■ Operation during Motor Overheating

The operation when the motor overheats can be selected using the parameters L1-03 and L1-04. Set the motor temperature input filter time parameter in L1-05. If the motor overheats, the OH3 and OH4 error codes will be displayed on the Digital Operator.

Fault Codes If the Motor Overheats

Fault Code	Details
OH3	Inverter stops or continues to operate, according to the setting in L1-03.
OH4	Inverter stops according to the setting in L1-04. The fault relay is activated

By setting H3-09 (Multi-function Analog Input Terminal A2 Function Selection) to E (Motor temperature input) the motor temperature can be detected and OH3 respectively OH4 can be output if the motor overheats. The terminal connections that are to be used are shown in *Fig 6.31*.

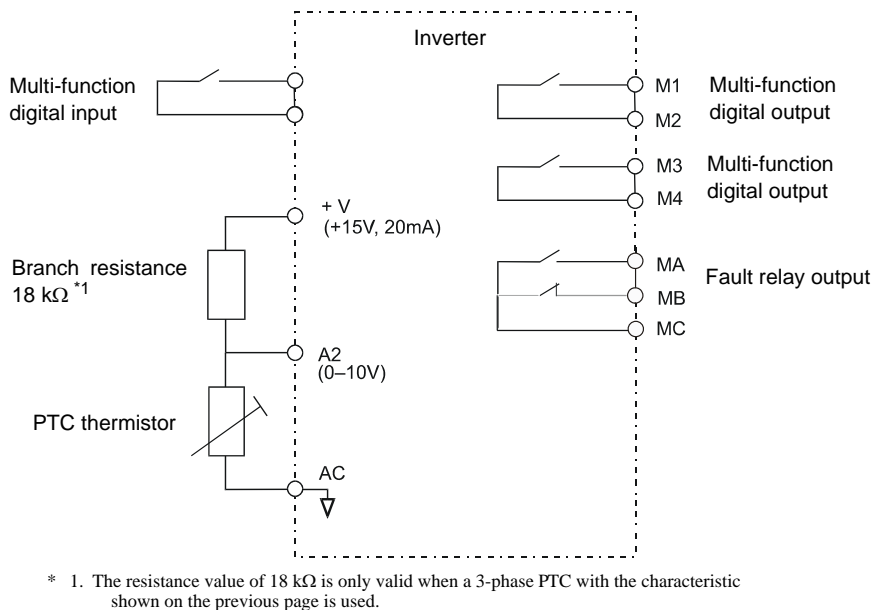

Fig 6.31 Terminal Connections for Motor Overheating Protection

Setting Precautions

Because this function uses a voltage signal to terminal A2, pin 2 of the DIP-switch S1 on the control terminal board has to be turned to OFF for A2 voltage input. The factory setting is ON (A2 current input). Refer to *Chapter 2, Switch S1 - Standard Terminal Board*.

For the same reason the parameter H3-08 (analog input terminal A2 signal level) has to be set to 0 (0-10V input).

◆ Limiting Motor Rotation Direction and Output Phase Rotation

If the motor reverse rotation is prohibited, a reverse run command will not be accepted, even if it is input. Use this setting for applications in which reverse motor rotation can cause problems (e.g., fans, pumps, etc.)

It is also possible to change the output phase order by changing b1-04 to 2 or 3. This is much easier and faster than changing the wiring if the motor rotational direction is wrong.

■ Related Parameters

Parameter Number	Name	Setting Range	Factory Setting	Change during Operation	Access Level
b1-04	Prohibition of reverse operation	0 to 3	0	No	A

Settings

- Setting 0: Both operation directions are enabled for the Inverter.
- Setting 1: Reverse operation is not enabled, a reverse RUN command is disregarded.
- Setting 2: Both operation directions are enabled, two output phases are exchanged
- Setting 3: Reverse operation is not enabled, a reverse RUN command is disregarded. Additional two output phases are exchanged.

Automatic Restart

This section explains functions for continuing or automatically restarting Inverter operation after a momentary power loss.

◆ Restarting Automatically After Momentary Power Loss

After a momentary power loss, the Inverter can be restarted automatically to continue motor operation.

To restart the Inverter after power is recovered, set L2-01 to 1 or 2.

If L2-01 is set to 1, the inverter will restart, when power is recovered within the time set in L2-02. If the power loss time exceeds the time set in L2-02, an UV1 fault (DC bus undervoltage) will be detected.

If L2-01 is set to 2, the inverter will restart, when the main power supply is recovered as long as the control power supply (i.e., power supply to the control circuit) is maintained. Consequently, alarm UV1 (DC bus undervoltage) will not be detected. Nevertheless, UV alarm is displayed.

■ Related Parameters

Parameter Number	Name	Setting Range	Factory Setting	Change during Operation	Access Level
L2-01	Momentary power loss detection	0 to 2	0	No	A
L2-02	Momentary power loss ride-through time	0 to 25.5	0.1 sec. *1	No	A
L2-03	Min. baseblock (BB) time	0.1 to 5.0	0.1 sec. *1	No	A
L2-04	Voltage recovery time	0.0 to 5.0	0.3 sec. *1	No	A
L2-05	Undervoltage (UV) detection level	150 to 210 *2	190 VDC *2	No	A

*1. The factory setting depends on the Inverter capacity. The value for a 200 V class Inverter of 0.4kW is given.

*2. Values for 200 V class Inverters are shown. For a 400 V class Inverter the values have to be doubled.

■ Setting Precautions

- Fault output signals are not output during momentary power loss recovery.
- To continue Inverter operation after power has been restored, ensure that the RUN command stays ON during the power loss
- L2-04 sets an acceleration time for the output voltage (from 0 V to normal voltage). After the power supply has returned the output voltage will be increased to the set value using the time set in L2-04.
- L2-05 sets the level at which UV is detected.

◆ Speed Search

The speed search function finds the actual speed of a motor that is coasting and then starts smoothly from that speed. It is also activated after momentary power loss detection when L2-01 is set to 1 or 2.

■ Related Parameters

Parameter Number	Name	Setting Range	Factory Setting	Change during Operation	Access Level
b3-01	Speed search selection (current detection or speed calculation)	0 to 3	2	No	A
b3-02	Speed search operating current (current detection)	0 to 200	120%	No	A
b3-03	Speed search deceleration time (current detection)	0.1 to 10.0	2.0 sec.	No	A
b3-05	Speed search wait time (current detection or speed calculation)	0.0 to 20.0	0.2 sec.	No	A
b3-14	Bi-directional speed search selection	0 or 1	1	No	A
L2-03	Min. baseblock time	0.1 to 5.0	0.1 sec.	No	A
L2-04	Voltage recovery time	0.0 to 5.0	0.3 sec.*1	No	A

*1. The factory setting depends on the Inverter capacity. The value for a 200 V class Inverter of 0.4kW is given.

Multi-function Digital Inputs

Set Value	Function
61	External speed search command 1 OFF: Speed search disabled (Acceleration starts from FMIN) ON: Speed calculation (Calculates the motor speed and starts search from the calculated speed) Current detection (Starts speed search from maximum output frequency)
62	External speed search command 2 OFF: Speed search disabled (Acceleration starts from FMIN) ON: Speed calculation (Calculates the motor speed and starts search from the calculated speed) (Same operation as external speed search command 1) Current detection: Starts speed search from set frequency (reference frequency when speed search command was input).
64	External speed search command 3 OFF: Inverter is base blocked ON: Inverter starts operation using speed search (same operation as speed search 2)

■ Setting Precautions

- When both external search commands 1 and 2 are set for the multi-function digital terminals, an OPE03 alarm will occur.
- If performing speed search using external search commands ensure that the RUN command and the external search command remain both ON.
- If the Inverter output is equipped with a contactor, set the contactor operation delay time in the Speed Search Wait Time (b3-05). The factory setting is 0.2 sec. If no contactor is used the setting can be reduced to 0 sec.
- Parameter b3-02 (current detection level for search completion) is effective only when current detection speed search is selected. When the current falls below the detection level, the speed search is supposed to be completed, and the motor accelerates or decelerates to the set frequency.
- Parameter b3-03 sets the time the output frequency is reduced during speed search until the actual motor speed is detected.
- If an overcurrent (OC) is detected when using speed search, lengthen the Minimum Baseblock Time (L2-03).
- If speed search is only desired in the last known operation direction set b3-14 to 1.

■ Application Precautions for Speed Calculation Speed Search

- Always perform non-rotating autotuning for line-to-line resistance before using speed searches based on calculated speeds.
- If the cable length between the motor and Inverter is changed after autotuning has been performed, perform stationary autotuning for line-to-line resistance again.

■ Speed Search Selection

The speed search method can be selected using b3-01. If b3-01 is set to 0 the search method is speed calculation. It has to be activated by a multi-function input (H1-□□ set to 61 or 62).

If b3-01 is set to 1, the search method is speed calculation too, but speed search is performed at every RUN command and has not to be activated by a multifunction input.

The same is valid for setting b3-01 to 2 or 3, only the search method is current detection and not speed calculation.

Search Name	Speed Calculation	Current Detection
Search Method	Calculates the motor speed at speed search start and accelerates or decelerates from the calculated speed to the set frequency. The direction of motor rotation is also detected.	Starts speed search from the last known frequency or the maximum output frequency. The output frequency is decreased until the output current falls below the speed search operating current.
External Speed Search Command	With external speed search command 1 and 2 the speed calculation is performed and the speed search started from the calculated speed.	External speed search command 1: Starts speed search from the maximum output frequency. External speed search command 2: Starts speed search from the frequency reference set before the search command.
Application Precautions	Cannot be used with multi-motor drives or with motors two or more sizes smaller than the Inverter capacity.	The motor may accelerate suddenly with light loads.

Examples for Speed Calculation

Search at Startup

The time chart for when speed search at startup and speed search to multi-function input terminals is shown below.

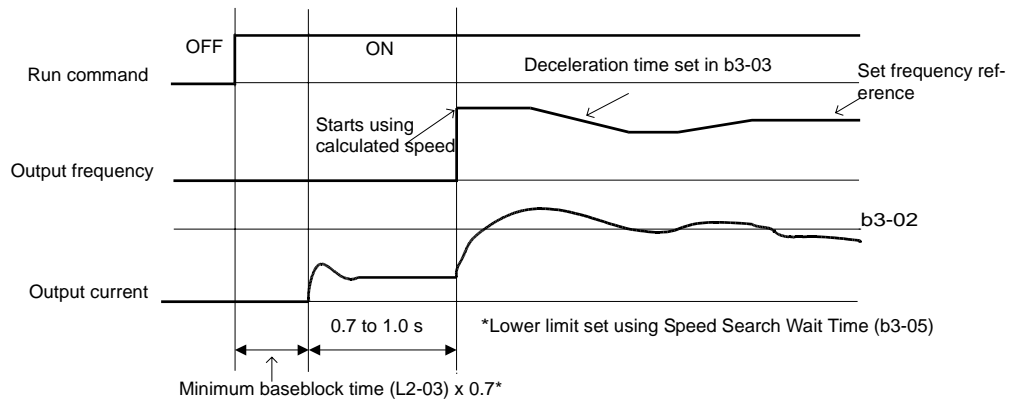

Note: If the stopping method is set to coast to stop, and the run command turns ON in a short time, the operation may be the same as the search in case 2.

Fig 6.32 Speed Search at Startup (Calculated Speed)

Speed Search after Short Baseblock (during Power Loss Recovery, etc.)

1. Loss Time shorter than the Minimum Baseblock Time (L2-03)

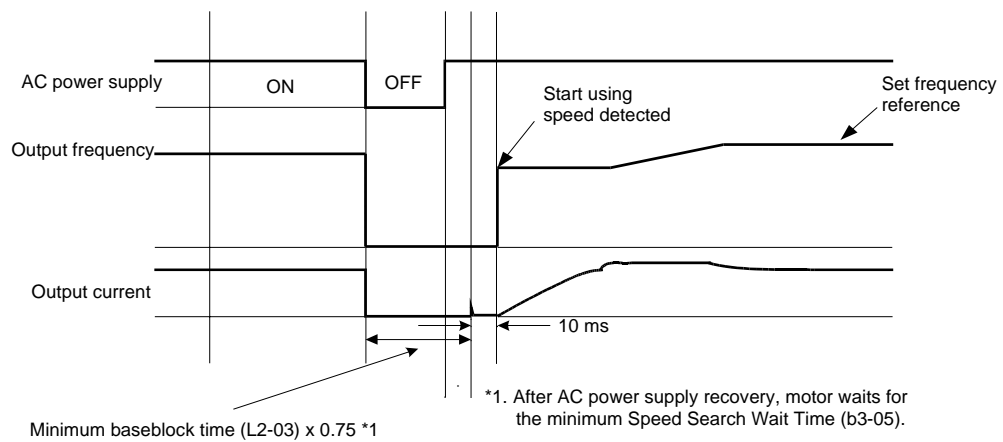

*1. After AC power supply recovery, motor waits for the minimum Speed Search Wait Time (b3-05).

Fig 6.33 Speed Search after Baseblock (Calculated Speed: Loss Time Is Set in L2-03)

2. Loss Time longer than the Minimum Baseblock Time (L2-03)

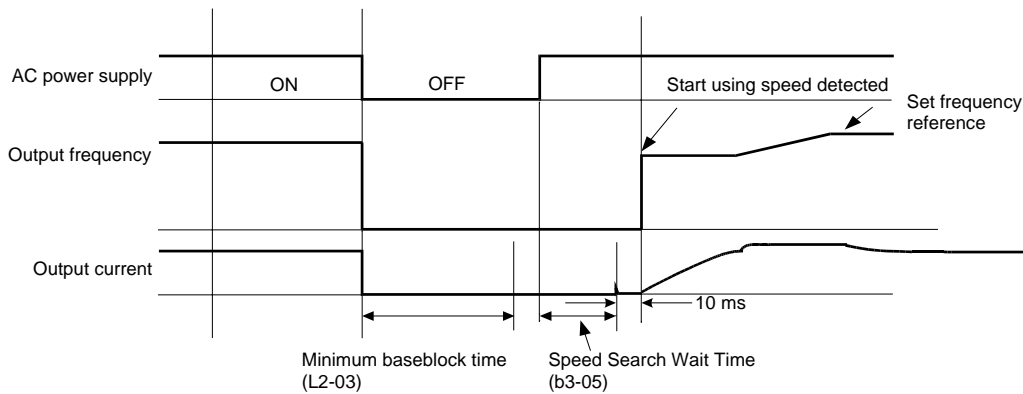

Note: If the frequency immediately before the baseblock is low or the power supply break time is long, operation may be the same as the search in case 1.

Fig 6.34 Speed Search after Baseblock (Calculated Speed: Loss Time > L2-03)

■ Examples for Current Detection

Speed Search at Startup

The time chart when speed search at startup or external speed search command is selected is shown below.

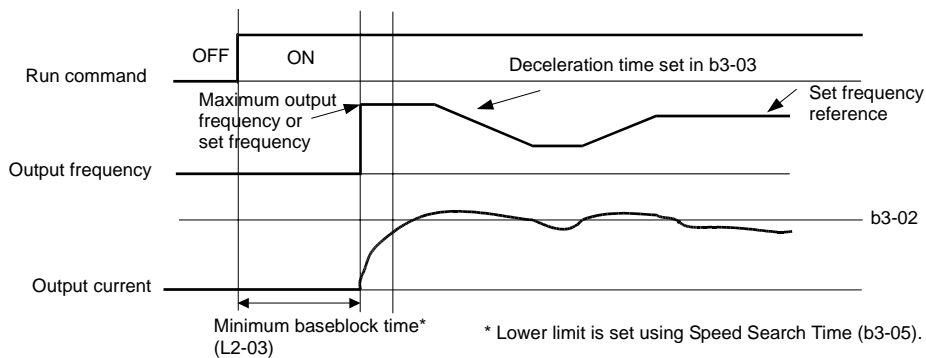

Fig 6.35 Speed Search at Startup (Current Detection)

Speed Search after Short Baseblock (during Power Loss Recovery, etc.)

1. Loss time shorter than minimum baseblock time

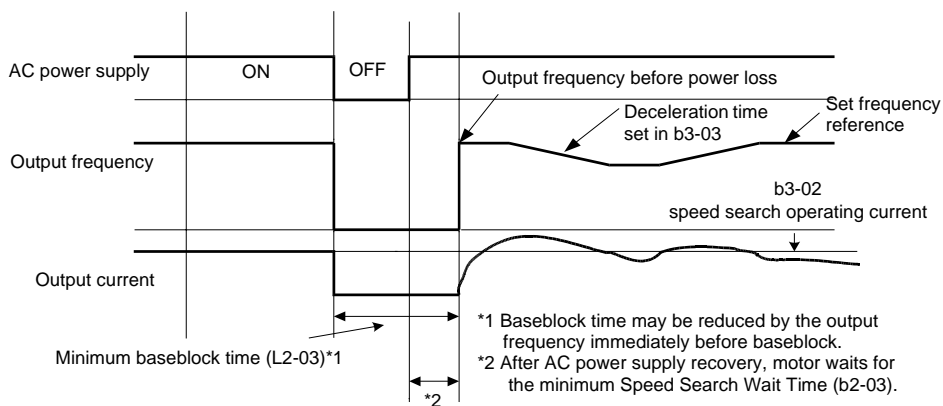

Fig 6.36 Speed Search After Baseblock (Current Detection: Loss Time < L2-03)

2. Loss time longer than minimum baseblock time

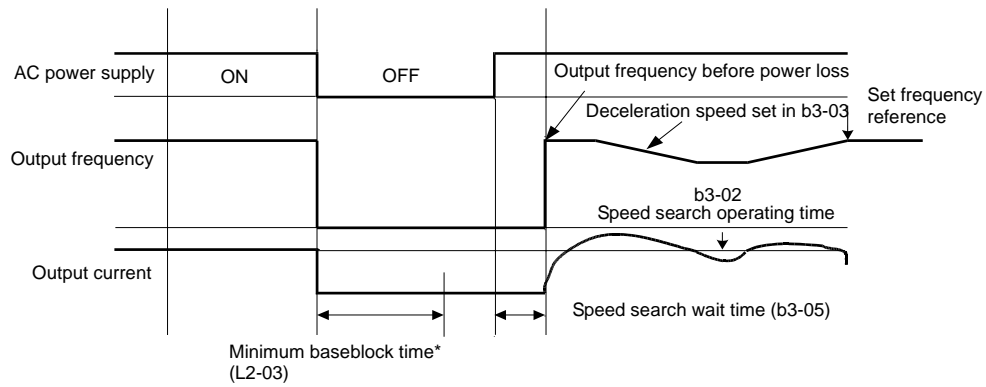

Fig 6.37 Speed Search After Baseblock (Current Detection: Loss Time > L2-03)

◆ Continuing Operation at Constant Speed When Frequency Reference Is Lost

The frequency reference loss detection function can be used to continue operation at reduced speed using the set value in parameter L4-06 as frequency reference value. When using an analog input as frequency reference source, a frequency reference loss is detected, when the reference value drops more than 90% in 400 msec or less.

When parameter L4-05 is set to 1 the Inverter will continue operation at the percentage in L4-06 of the last active frequency reference.

An fault signal during frequency reference loss can be output if H2-01 or H2-02 (Terminal M1-M2/M3-M4 function selection) to C (Loss of frequency reference).

■ Related Parameters

Parameter Number	Name	Setting Range	Factory Setting	Change during Operation	Access Level
L4-05	Operation when frequency reference is missing	0 or 1	1	No	A
L4-06	Frequency reference value at frequency reference loss	0 to 100%	80%	No	A

Multi-function Digital Outputs (H2-01 to H2-02)

Set Value	Function
C	Loss of frequency reference

◆ Restarting Operation After Transient Fault (Auto Restart Function)

If an Inverter fault occurs during operation, the Inverter will perform self-diagnosis. If no fault is detected, the Inverter will automatically restart. This is called the auto restart function.

■ Related Parameters

Parameter Number	Name	Setting Range	Factory Setting	Change during Operation	Access Level
L5-01	Number of auto restart attempts	0 to 10	0	No	A
L5-02	Auto restart operation selection	0 or 1	0	No	A
L5-03	Fault Retry Time	0.5 to 180.0	10.0 s	No	A

Multi-function Digital Outputs (H2-01 to H2-02)

Set Value	Function
1E	Automatic restart enabled

Application Precautions

- The auto restart function can be applied to the following faults.
 - OC (Overcurrent)
 - GF (Ground fault)
 - PUF (DC bus fuse blown)
 - OV (Main circuit overvoltage)
 - UV1 (DC Bus Undervoltage, Main Circuit MC Operation Failure)*1
 - PF (Main circuit voltage fault)
 - OL1 (Motor overload)
 - OL2 (Inverter overload)
 - OH1 (Motor overheat)
 - OL3 (Overload)

*1. When L2-01 is set to 1 or 2 (continue operation during momentary power loss)

If a fault that is not listed above occurs the Inverter will not restart automatically and remain in fault condition.

- If the fault output should be operated during auto restart L5-02 has to be set to 1
- The number of auto restarts is set in parameter L5-01. If a fault occurs the inverter performs the auto restart corresponding to [Fig 6.38](#). The inverter tries to restart every 5 msec for the maximum time of L5-03. All retries performed during L5-03 are regarded as one restart attempt.
The internal counting of restart attempts is reset to 0 when the drive has run 10 minutes without fault.

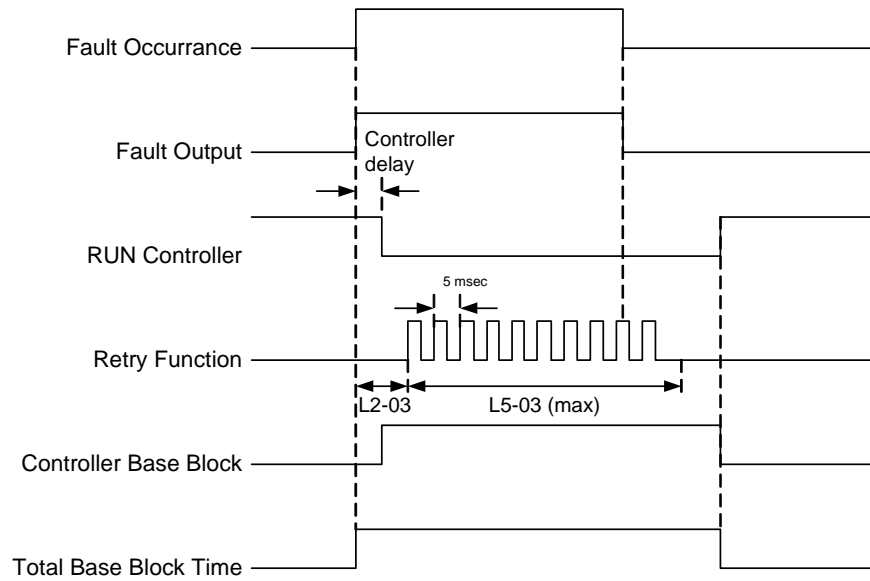

Fig 6.38 Timing Chart for Auto Restart Function

■ Application Precautions

The number of auto restarts counter is reset under the following conditions:

- After auto restart, normal operation has continued for 10 minutes.
- After the protection operation has been performed and an fault reset has been input.
- After the power supply is turned OFF, and then ON again.

Inverter Protection

◆ Inverter Overheat Protection

The Inverter is protected against overheating using a thermistor that detects the heatsink temperature.

Related Parameters

Parameter Number	Name	Setting Range	Factory Setting	Change during Operation	Access Level
L8-02	Overheat pre-alarm level	50 to 130	95°C	No	A
L8-03	Inverter overheat (OH) pre-alarm operation selection	0 to 4	4	No	A
L8-19	Frequency reference during OH pre-alarm	0.0 to 20.0%	20.0%	No	A

Multi-function Digital Outputs (H2-01 to H2-02)

Set Value	Function
20	Inverter overheat pre-alarm (ON when overheat pre-alarm is active)

When the overheat temperature level is reached the inverter output is switched off.

To prevent a sudden and unexpected stop of the inverter due to an overtemperature, an overheating pre-alarm can be output. Parameter L8-02 selects the pre-alarm temperature level, parameter L8-03 selects the inverter reaction on the pre-alarm:

- Setting 0: The Inverter decelerates to stop using deceleration time C1-02, OH fault is output.
- Setting 1: The Inverter coasts to stop, OH fault is output.
- Setting 2: The Inverter decelerates to stop using the emergency stop time C1-09, OH fault is output.
- Setting 3: The Inverter will continue operation and only display an OH alarm on the operator display.
- Setting 4: The Inverter will continue operation but reduce the output frequency order to reduce the load. Parameter L8-19 defines the decrease in output frequency as a percentage of the maximum output frequency E1-04. An OH alarm is output.

◆ Input Phase Loss Detection Level

For the Input Phase Loss Detection the drive monitors the DC bus ripple. The drive integrates this ΔV value over 10 scans (appr. 10 seconds). If the integrated ΔV value of any consecutive ten scan range is greater than the voltage determined by multiplying L8-06 times the drives rated OV Trip point (400 VDC/800 VDC), a PF fault will occur and the Drive will coast to stop.

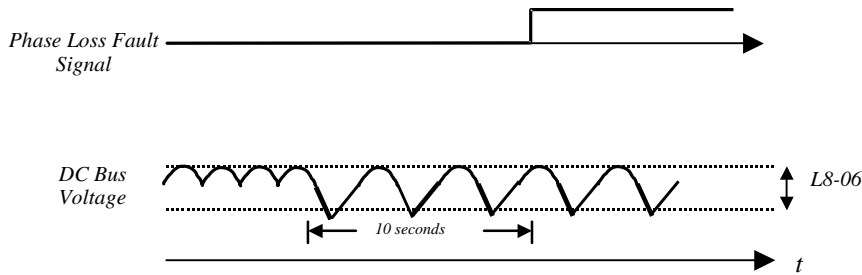

Fig 6.39 Input Phase Loss Detection

■ Related Parameters

Parameter Number	Name	Setting Range	Factory Setting	Change during Operation	Access Level
L8-06	Input Phase Loss Detection Level	0.0 to 25.0%	5.0% *1	No	A

*1. The factory setting depends on the Inverter capacity. The value for a 200 V class Inverter of 0.4 kW is given.

◆ Ground Fault Protection

The ground fault protection function detects the earth leakage current by calculating the sum of the three output currents. Normally this sum should be 0. If the sum exceeds 50% of the Inverter rated current a GF fault is detected and the motor coasts to stop.

The ground fault protection can be disabled by setting L8-09 to 0. It is not recommended to disable the ground fault protection.

■ Related Parameters

Parameter Number	Name	Setting Range	Factory Setting	Change during Operation	Access Level
L8-09	Ground fault protection selection	0 or 1	1	No	A

◆ Cooling Fan Control

This function controls the fan that is mounted to the inverters heatsink.

■ Related Parameters

Parameter Number	Name	Setting Range	Factory Setting	Change during Operation	Access Level
L8-10	Cooling fan control selection	0 or 1	0	No	A
L8-11	Cooling fan control delay time	0 to 300	300 sec.	No	A
L8-32	OH1 detection selection for fan failure	0 or 1	1	No	A

Multi-function Relay Outputs (H2-01 to H2-02)

Set Value	Function
3D	Cooling fan fault (ON: internal cooling fan fault)

■ Selecting the Cooling Fan Control

Using parameter L8-10 two modes can be selected:

0: The fan is ON only when the inverter output is ON, i.e. a voltage is output. This is the factory setting.

1: The fan is ON whenever the inverter power supply is switched ON.

If L8-10 is set to 0, the turn OFF delay time for the fan can be set in parameter L8-11. After switching OFF the RUN command the inverter waits for this time before the cooling fan is switched. The factory setting is 300 sec.

Parameter L8-32 selects whether failure of the internal cooling fan will lead to an OH1 fault or not. The factory setting is 0. This disables the OH1 fault in case of fan failure and displays a FAN alarm instead. Setting 1 activates the OH1 fault also in case of a internal fan failure.

■ Application Precautions

When L8-32 is set to 0 and the internal fan fails the Inverter's overload capability is automatically derated by 10%. The overload time at 100% of the Inverter rated current becomes 30 seconds and the overload time at 120% becomes 10 seconds.



If using L8-32 = 0 a multi-function output should be set to 10 (Alarm) or 3D (Cooling Fan Error) to indicate to peripheral equipment that the Inverter's internal cooling fan has failed. Under this condition the Inverter should be immediately stopped and serviced for fan replacement. If the Inverter continues to run in this state, its internal temperature will increase, resulting in a potential decrease of lifetime.

◆ Setting the Ambient Temperature

The overload capability of the inverter depends on the ambient temperature. At ambient temperatures higher than 45°C (40°C for Inverters in protection class IP20 / NEMA1) the output current capacity is reduced, i.e. the OL2 alarm level will be lowered. Refer to [Fig 6.40](#) for the output current derating.

■ Related Parameters

Parameter Number	Name	Setting Range	Factory Setting	Change during Operation	Access Level
L8-12	Ambient temperature	45 to 60	45 °C	No	A

The ambient temperature must be set in parameter L8-12.

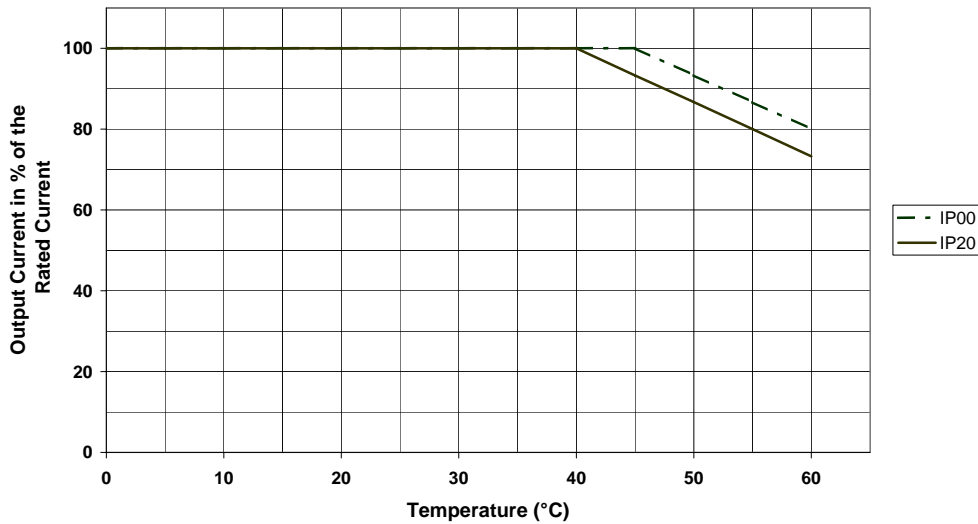

Fig 6.40 Ambient Temperature Derating Curve

◆ OL2 Characteristics at Low Speed

At output frequencies below 6 Hz the overload capability of the inverter is lower than at higher speeds, i.e. an OL2 fault (inverter overload) may occur even if the current is below the normal OL2 current level (see [Fig 6.41](#)).

The special OL2 characteristics can be disabled by setting parameter L8-15 to 0. Generally is not recommended to disable that function as the Inverter lifetime might be shortened.

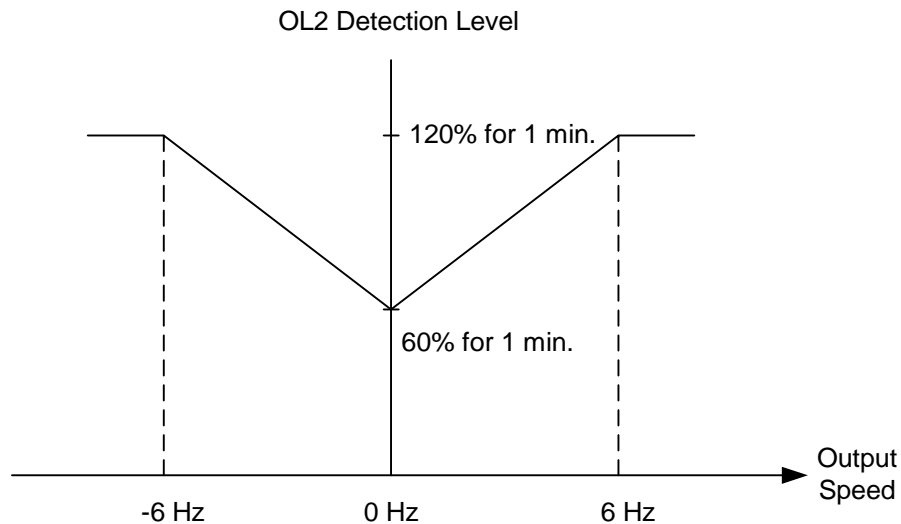

Fig 6.41 OL2 Alarm Level at Low Frequencies

■ Related Parameters

Parameter Number	Name	Setting Range	Factory Setting	Change during Operation	Access Level
L8-15	OL2 characteristics selection at low speeds	0 or 1	1	No	A

◆ Soft CLA Selection

Soft CLA (software current level A) is a current detection level for the output IGBT protection. It is only active during acceleration and lowers the output voltage quickly to reduce the current in order to protect the IGBTs.

The Soft CLA function can be disabled by setting parameter L8-18 to 0. Generally it is absolutely not recommended to disable this function.

■ Related Parameters

Parameter Number	Name	Setting Range	Factory Setting	Change during Operation	Access Level
L8-18	Soft CLA selection	0 or 1	1	No	A

Input Terminal Functions

◆ Temporarily Switching Operation between Digital Operator and Control Circuit Terminals

The Inverter's run command and frequency reference inputs can be switched between local (i.e., Digital Operator) and remote (input method set in b1-01 and b1-02).

If any parameter from H1-01 to H1-05 (terminal S3 to S7 function selection) has been set to 1 (local/remote selection), this input can be used to switch over between local and remote operation.

To set the frequency reference source and RUN command source to control circuit terminals, set b1-01 and b1-02 to 1.

■ Related Parameters

Parameter Number	Name	Setting Range	Factory Setting	Change during Operation	Access Level
b1-01	Reference selection	0 to 3	1	No	Q
b1-02	RUN command source selection	0 to 3	1	No	Q

Multi-function Digital Inputs (H1-01 to H1-05)

Set Value	Function
1	Local/Remote selection (ON: Operator; OFF: Parameter b1-01/b1-02 setting)



NOTE

Local/remote switching can also be performed using the LOCAL/REMOTE key on the Digital Operator. When the local/remote selection has been set for one external terminal, the LOCAL/REMOTE key function on the Digital Operator will be disabled.

◆ Blocking the Inverter Output (Baseblock Command)

Set 8 or 9 (Baseblock command NO/NC) in one of the parameters H1-01 to H1-05 (terminal S3 to S7 function selection) to perform baseblock commands and thereby to block the inverter output.

Clear the baseblock command to restart the operation using the speed search method set in b3-01 (speed search selection). Otherwise the Inverter may trip as it will start at the same frequency reference again.

Multi-function Digital Inputs (H1-01 to H1-05)

Set Value	Function
8	External baseblock NO (ON: Inverter is baseblocked)
9	External baseblock NC (OFF: Inverter is baseblocked)

■ Time Chart

The time chart when using a baseblock command is shown below.

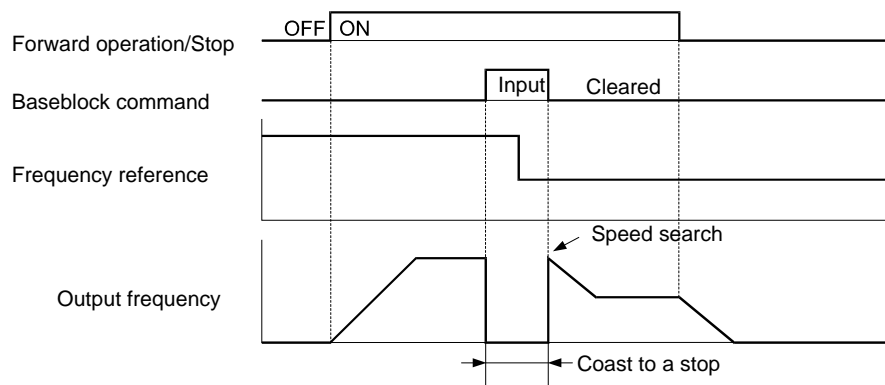

Fig 6.42 Baseblock Commands



When a contactor between inverter and motor is used, always perform a base block command before opening the contactor.

◆ Multifunction Analog Input A2 Disable/Enable

If a digital input is programmed to setting C the analog input A2 can be enabled or disabled by switching the digital input.

Multi-function Digital Inputs (H1-01 to H1-05)

Set Value	Function
C	Multi-function analog input A2 enable (ON: A2 is enabled)

◆ Drive Enable/Disable

If a digital input is programmed to setting 6A the Inverter can be enabled or disabled by switching the digital input

If the input is switched OFF while a RUN command is active the inverter will stop using the stopping method set in b1-03.

The Drive Enable/Disable signal has to be ON before the RUN command is activated.

Multi-function Digital Inputs (H1-01 to H1-05)

Set Value	Function
6A	Drive enable (ON: Inverter enabled)

◆ Bypass Drive Enable

If a digital input is programmed to setting 70 the Inverter will not execute a RUN command until this input is closed.

Unlike the setting 6A (Drive Enable/Disable) the RUN command does not need to be cycled after closing the input. The Inverter will start whenever the digital input is closed a RUN command is active with the activated acceleration time.

If a RUN command is active and the Bypass Drive Enable input is OFF the digital operator shows the alarm message “dnE”.

Multi-function Digital Inputs (H1-01 to H1-05)

Set Value	Function
70	Bypass Drive enable (ON: Inverter is enabled)

◆ Stopping Acceleration and Deceleration (Acceleration/Deceleration Ramp Hold)

- If a digital input is programmed to setting A the Inverter will pause the acceleration or deceleration and hold the output frequency when the input is closed.
- Acceleration/deceleration is restarted when the input is turned OFF.
- The motor will be stopped if a stop command is input while the acceleration/deceleration ramp hold input is ON.
- When parameter d4-01 (the frequency reference hold function selection) is set to 1, the held frequency will be stored in memory. This stored frequency will be retained as frequency reference even after a power loss and the motor will be restarted at this frequency when a run command is input again.

■ Related Parameters

Parameter Number	Name	Setting Range	Factory Setting	Change during Operation	Access Level
d4-01	Frequency reference hold function selection	0 or 1	0	No	A

Multi-function Digital Inputs (H1-01 to H1-05)

Set Value	Function
A	Accel./Decel. Ramp Hold

■ Time Chart

The time chart when using Acceleration/Deceleration Ramp Hold commands is given below.

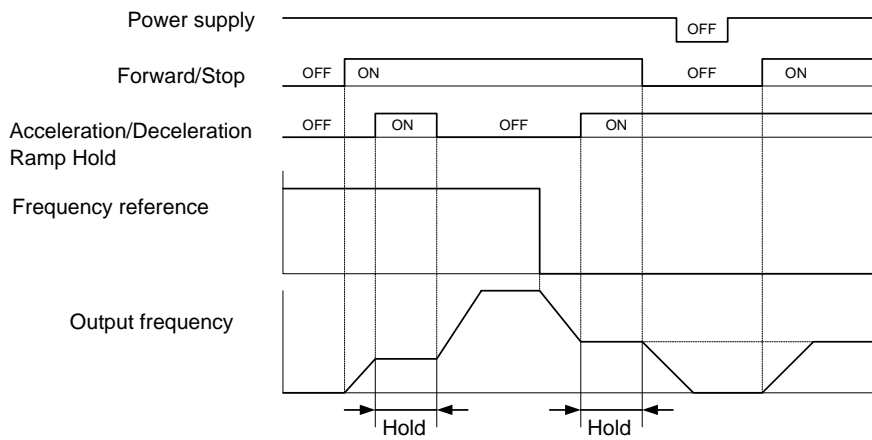

Fig 6.43 Acceleration/Deceleration Ramp Hold

◆ Raising and Lowering Frequency References Using Digital Input Signals (UP/DOWN)

The UP and DOWN commands raise and lower Inverter frequency references by turning ON and OFF a multi-function digital input terminal S3 to S7.

To use this function, set two of the parameters H1-01 to H1-05 (digital input terminal S3 to S7 function selection) to 10 (UP command) and 11 (DOWN command).

The table below shows the possible combinations of the UP and DOWN command and the corresponding operation.

Operation	Acceleration	Deceleration	Hold	
UP command	ON	OFF	ON	OFF
DOWN command	OFF	ON	ON	OFF

The change of the output frequency depends on the acceleration and deceleration times. Be sure to set b1-02 (Run command selection) to 1 (Control circuit terminal).

■ Related Parameters

Parameter Number	Name	Setting Range	Factory Setting	Change during Operation	Access Level
d2-01	Frequency reference upper limit	0.0 to 110.0	100.0%	No	A
d2-02	Frequency reference lower limit	0.0 to 110.0	0.0%	No	A
d2-03	Master speed reference lower limit	0.0 to 110.0	0.0%	No	A
d4-01	Frequency reference hold function selection	0 or 1	0	No	A

Multi-function Digital Inputs (H1-01 to H1-05)

Set Value	Function
10	UP command
11	DOWN command

■ Setting Precautions

An OPE03 alarm will occur if one of the following settings are programmed:

- Only either the UP command or DOWN command has been set.
- UP/DOWN commands and Acceleration/Deceleration Ramp Hold have been programmed to digital inputs at the same time.

■ Application Precautions

- When the frequency reference is input by UP/DOWN commands the frequency is limited by the parameters d2-01 to d2-03 (Reference Limits, set in% of the maximum output frequency).
- When the frequency reference is input by UP/DOWN commands the analog input A1 becomes the frequency reference lower limit. If a combination of the frequency reference from terminal A1 and the frequency reference lower limit is set in either parameter d2-02 or d2-03, the larger limit value will become the frequency reference lower limit.
- If a frequency reference lower limit is set and the RUN command is activated the drive accelerates to the lower limit.
- Multi-step operation is disabled when UP/DOWN commands are used.
- When d4-01 (Frequency Reference Hold Function Selection) is set to 1, the last frequency reference value is stored even after the power supply is turned OFF. When the power supply is turned ON and the run command is input, the motor accelerates to the frequency reference that has been stored. To reset (i.e., to 0 Hz) the stored frequency reference, turn ON the UP or DOWN command before the power is switched on.

■ Connection Example and Time Chart

The time chart and settings example when the UP command is allocated to the multi-function Digital Input terminal S3, and the DOWN command is allocated to terminal S4, are shown below.

Parameter	Name	Set Value
H1-01	Multi-function input (terminal S3)	10
H1-02	Multi-function input (terminal S4)	11

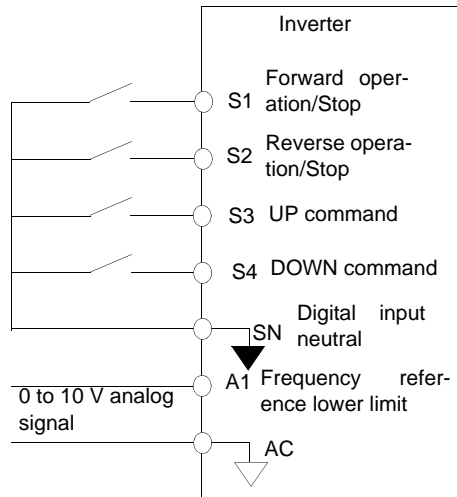
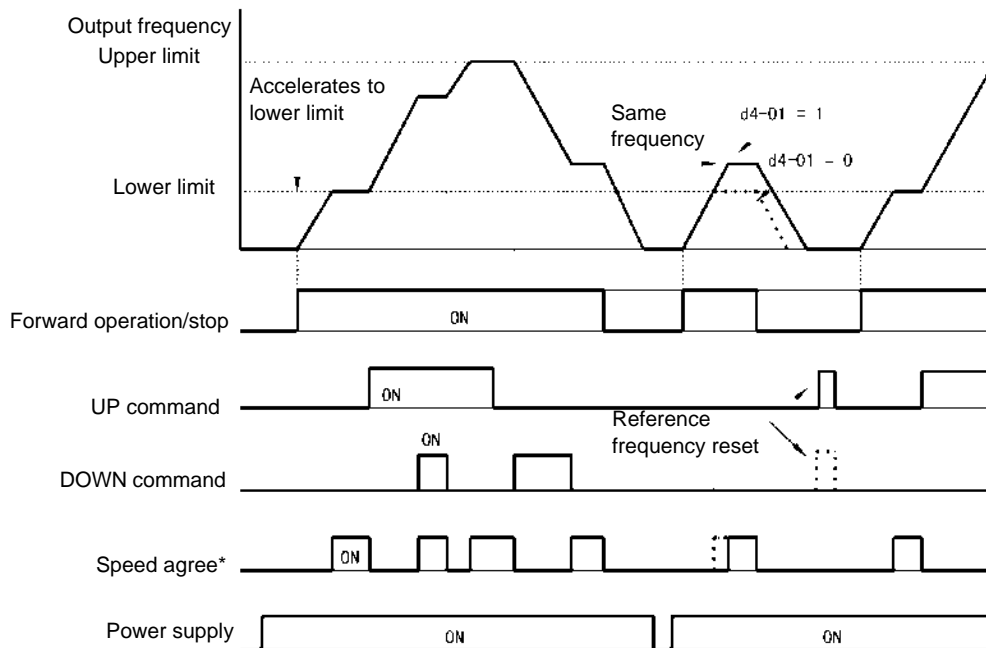

Fig 6.44 Connection Example when UP/DOWN Commands Are Allocated



* The speed agree signal turns ON when the motor is not accelerating/ decelerating while the RUN command is ON.

Fig 6.45 UP/DOWN Commands Time Chart

◆ Trim Control Function

The trim control function increments or decrements the frequency reference from analog input by the value set in parameter d4-02 (Trim control level, set in% of maximum output frequency) using two digital inputs.

To use this function, set two of the parameters H1-01 to H1-05 (digital input S3 to S7 function selection) to 1C (Trim Control Increase) and 1D (Trim Control Decrease).

■ Related Parameters

Parameter Number	Name	Setting Range	Factory Setting	Change during Operation	Access Level
d4-02	Trim control level	0 to 100	10%	No	A

Multi-function Digital Inputs (H1-01 to H1-05)

Set Value	Function
1C	Trim Control Increase
1D	Trim Control Decrease

■ Trim Control Increase/Decrease Command and Frequency Reference

The frequency references using Trim Control Increase/Decrease command ON/OFF operations are shown below.

Frequency Reference	Set Frequency Reference + d4-02	Set Frequency Reference - d4-02	HOLD	
Trim Control Increase	ON	OFF	ON	OFF
Trim Control Decrease	OFF	ON	ON	OFF

■ Setting Precautions

An OPE03 alarm will occur if only one of the trim control commands is programmed.

■ Application Precautions

- Trim Control Increase/Decrease command is enabled when speed reference > 0 and the speed reference source is one of the analog input (A1 or A2).
- When the (analog frequency reference value - d4-02) < 0, the frequency reference is set to 0.

◆ Analog Frequency Reference Sample/Hold

If one of the parameters H1-01 to H1-05 (digital input terminal S3 to S7 function selection) is set to 1E (analog frequency reference sample/hold) the analog frequency reference will be sampled and held whenever the digital input remains ON for at least 100 milliseconds.

The analog value 100 ms after the command is turned ON is used as the frequency reference.

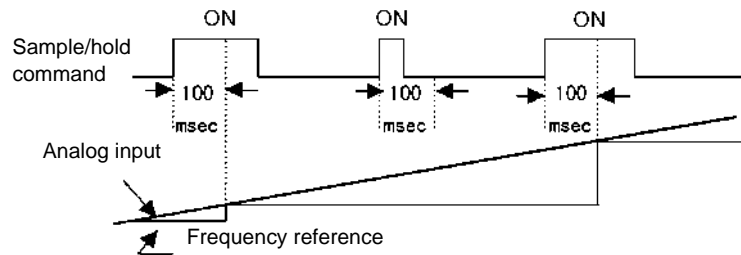

Fig 6.46 Sample/Hold Analog Frequency

■ Related Parameters

Multi-function Digital Inputs (H1-01 to H1-05)

Set Value	Function
1E	Analog frequency reference sample/hold (ON: Frequency reference sample/hold)

■ Setting Precautions

An OPE03 alarm will occur if the following functions are programmed to digital inputs additional to the analog frequency reference sample/hold function:

- Acceleration/Deceleration Ramp Hold (setting A)
- UP/DOWN (settings 10/11)
- Trim Control Increase/Decrease (settings 1C/1D)

■ Application Precautions

- When performing analog frequency reference sample/hold of, be sure to close the digital input for 100 msec or more. If the input is ON for less than 100 msec it will be ignored.
- The frequency reference value that is held will be deleted when the power supply is turned OFF.

◆ Switching Operation Source to Communication Option Card

The source of frequency reference and RUN command can be switched between a Communication option card and the sources selected in b1-01 and b1-02. Set one of the parameters H1-01 to H1-05 (digital input S3 to S7 function selection) to 2 or 36 to enable operation source switchover.

If a RUN command is active, the switchover will not be accepted.

■ Related Parameters

Multi-function Digital Inputs (H1-01 to H1-05)

Set Value	Function
2	Operation Source Option Card/Inverter selection (ON: Parameter b1-01/b1-02 setting)
36	Operation Source Option/Inverter selection 2 (ON: option card)

■ Setting Precautions

To use the operation source switching function make the following settings:

- Set b1-01 (frequency reference source) to a value different from 3 (option card).
- Set b1-02 (RUN command source) to a value different from 3 (option card).
- Set one of the parameters H1-01 to H1-05 to 2 or 36.

Setting for one of H1-01 to H1-05	Terminal Status	Frequency Reference and Run Command Source
2	OFF	Communication option card (Frequency reference and run command are input from communications option card)
	ON	Inverter (Frequency reference and Run command source are set in b1-01 and b1-02)
36	OFF	Inverter (Frequency reference and Run command source are set in b1-01 and b1-02)
	ON	Communication option card (Frequency reference and run command are input from communications option card)

◆ Switching Operation Source to MEMOBUS communication

The frequency reference and RUN command source can be switched between the MEMOBUS communication via RS-422/485 and the inverter settings in b1-01 and b1-02. Therefore set one of the parameters H1-01 to H1-05 (digital inputs terminals S3 to S7 function selection) to 6B or 6C.

If a RUN command is active the switchover will not be accepted.

■ Related Parameters

Multi-function Digital Inputs (H1-01 to H1-05)

Set Value	Function
6B	Operation source communication/Inverter selection (ON: RS-422/485 port active)
6C	Operation source communication/Inverter selection 2 (ON: inverter settings active)

■ Setting precautions

To use the operation source switching function make the following settings:

- Set b1-01 (Frequency reference source) to a value different from 2 (Memobus)
- Set b1-02 (RUN command source) to a value different from 2 (Memobus)
- Set one of the parameters H1-01 to H1-05 to 6B or 6C

Setting for one of H1-01 to H1-05	Terminal Status	Frequency Reference and Run Command Source
6B	OFF	Inverter (Frequency reference and Run command source are set in b1-01 and b1-02)
	ON	MEMOBUS communication (Frequency reference and run command are input via Memobus, RS-422/485 port)
6C	OFF	MEMOBUS communication (Frequency reference and run command are input via Memobus, RS-422/485 port)
	ON	Inverter (Frequency reference and Run command source are set in b1-01 and b1-02)

◆ AUTO/HAND Mode Switching by Digital Input

If the HOA Digital Operator (optional available) is connected the Inverter can be switched to AUTO or HAND mode with digital inputs.

If b1-13 (HAND/AUTO switching during run selection) is set to 1 this is also possible during run, otherwise the Inverter has to be stopped to enable the switchover. Depending on the setting of b1-13 the functionality of b1-12 (HAND frequency reference source selection) changes.

■ Related Parameters

Parameter Number	Name	Setting Range	Factory Setting	Change during Operation	Access Level
b1-12	HAND frequency reference source selection	0 or 1	0	No	A
b1-13	HAND/AUTO switching during run selection	0 or 1	0	No	A

Multi-function Digital Inputs (H1-01 to H1-05)

Set Value	Function
6D	AUTO mode selection (ON: AUTO mode active)
6E	HAND mode selection (ON: HAND mode active)

■ Application Precautions

Following table shows the behavior of the Inverter depending on the setting of b1-12 and b1-13.

Setting of b1-12	Setting of b1-13	HAND/AUTO Switching Behaviour
0 (Operator)	0 (Disabled)	Inverter has to be stopped for HAND/AUTO switchover. If started in HAND mode d1-01 becomes the active frequency reference.
	1 (Enabled)	Inverter can be switched over during run. When switched to HAND mode the last AUTO frequency reference is used in HAND mode and copied into d1-01.
1 (Terminals)	0 (Disabled)	Inverter has to be stopped for HAND/AUTO switchover. If started in HAND mode the AUTO frequency reference is used.
	1 (Enabled)	Inverter can be switched over during run. When switched to HAND mode d1-01 becomes the active frequency reference.

■ Setting Precautions

- The status of the digital inputs programmed to AUTO mode selection or HAND mode selection will override any digital operator selections.
- If a Digital Operator different from the HOA Digital Operator is connected to the Inverter the digital inputs AUTO mode selection and HAND mode selection will be ignored.
- An OPE3 alarm will occur when AUTO mode selection and HAND mode selection are assigned to 2 digital inputs simultaneously.

◆ Jog Frequency Operation without Forward and Reverse Commands (FJOG/RJOG)

The FJOG/RJOG function operates the inverter at the jog frequency. This function includes a RUN command, it does not need to be set additionally.

■ Related Parameters

Parameter Number	Name	Setting Range	Factory Setting	Change during Operation	Access Level
d1-17	Jog frequency reference	0 to 200.00	6.00 Hz	Yes	A

Multi-Function Digital Inputs (H1-01 to H1-05)

Set Value	Function
12	FJOG command (ON: Forward run at jog frequency d1-17)
13	RJOG command (ON: Reverse run at jog frequency d1-17)

■ Application Precautions

- Jog frequencies using FJOG and RJOG commands will override any other frequency references.
- When both FJOG command and RJOG commands are ON for 500 ms or longer at the same time, the Inverter stops according to the setting in b1-03 (stopping method selection).

◆ Stopping the Inverter on External Faults (External Fault Function)

The external fault function can activate the fault relay output and can stop the Inverter operation by a digital input. The Digital Operator will display EFx where x is the number of the digital input the fault signal is connected to.

To use the external fault function, set one of the values 20 to 2F in one of the parameters H1-01 to H1-05 (digital input terminal S3 to S7 function selection).

Select the value to be set in H1-01 to H1-05 from a combination of any of the following three conditions.

- Signal logic from peripheral devices
- External fault detection method
- Operation during external fault detection

The following table shows the relationship between the combinations of conditions and the set value in H1-01 to H1-05.

Set Value	Signal Logic		Fault Detection Method		Operation During Fault Detection			
	NO Contact	NC Contact	Continuous Detection	Detection During Operation	Decelerate to Stop (Fault)	Coast to Stop (Fault)	Fast Stop (Fault)	Continue Operation (Warning)
20	Yes		Yes		Yes			
21		Yes	Yes		Yes			
22	Yes			Yes	Yes			
23		Yes		Yes	Yes			
24	Yes		Yes			Yes		
25		Yes	Yes			Yes		
26	Yes			Yes		Yes		
27		Yes		Yes		Yes		
28	Yes		Yes				Yes	
29		Yes	Yes				Yes	
2A	Yes			Yes			Yes	
2B		Yes		Yes			Yes	
2C	Yes		Yes					Yes
2D		Yes	Yes					Yes
2E	Yes			Yes				Yes
2F		Yes		Yes				Yes

Output Terminal Functions

The digital multifunction outputs can be set for several functions using the H2-01 and H2-02 parameters (terminal M1 to M4 function selection). These functions are described in the following section.

■ Related Parameters

Parameter Number	Name	Setting Range	Factory Setting	Change during Operation	Access Level
H2-01	Terminal M1-M2 function selection	0 to 3D	0	No	A
H2-02	Terminal M3-M4 function selection	0 to 3D	1	No	A

■ During Run (Setting: 0) and During Run 2 (Setting: 37)

During Run (Setting: 0)

OFF	The RUN command is OFF, the Inverter output is OFF
ON	The RUN command is ON, the Inverter output is giving out a voltage.

During Run 2 (Setting: 37)

OFF	The Inverter does not give out a frequency. (During baseblock, DC injection or stopped)
ON	The Inverter gives out a frequency.

These outputs can be used to indicate the Inverter's operating status.

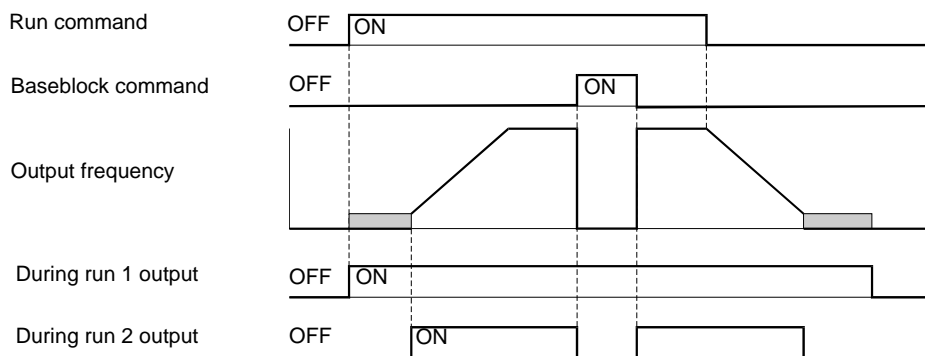

Fig 6.47 Timing Chart for During Run and During Run 2 Output

■Zero Speed (Setting: 1)

OFF	The output frequency is higher than the zero speed level (DC injection braking start level, b2-01).
ON	The output frequency is lower than the zero speed level (DC injection braking start level, b2-01).

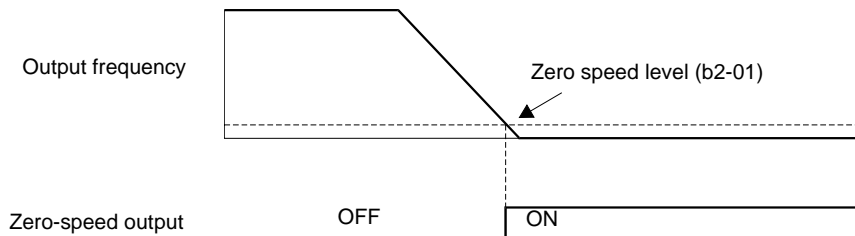

Fig 6.48 Timing Chart for Zero-speed

■Inverter Operation Ready (Setting: 6)

If a multi-function digital output is programmed to 6 the output will be switched ON when the initialisation of the Inverter at startup has finished without any faults.

■During DC Bus Undervoltage (Setting: 7)

If a multi-function digital output is programmed to 7 the output is switched ON as long as a DC bus undervoltage is detected.

■During Baseblock (Setting: 8)

If a multi-function digital output is programmed to 8 the output is switched ON as long as the Inverter output is base blocked.

■Frequency Reference Source Selection (Setting: 9)

If a multi-function digital output is programmed to 9 the output is ON when the Digital Operator is selected as frequency reference source. If any other frequency reference is selected the output is switched OFF.

■Run Command Source Selection Status (Setting: A)

If a multi-function digital output is programmed to A the output is switched ON when the digital operator is selected as RUN command source. If any other RUN command source is selected output is switched OFF.

■Fault (Setting: E)

If a multi-function digital output is programmed to E the output is switched ON when any fault different from CPF00 and CPF01 occurs. The output is also not switched in alarm condition. (Refer to [Chapter 7, Troubleshooting](#) for fault and alarm lists.)

■Minor Fault (Alarm) (Setting: 10)

If a multi-function digital output is programmed to 10 the output is switched ON when the Inverter is in alarm condition (refer to [page 7-8, Alarm Detection](#) pp.).

■ Fault Reset Command Active (Setting: 11)

If a multi-function digital output is set to 11 the output is switched ON as long as a fault reset command is input at one of the digital inputs.

■ Reverse Direction (Setting: 1A)

If a multi-function digital output is programmed for this function the output is switched ON whenever the motor is rotating in reverse direction.

■ OH Pre-Alarm (Setting: 20)

The overheat fault function (OH) is designed to protect the Inverter from excessive temperature damage. Thermistors attached to the heatsink of the Inverter monitor the temperature and will make the Inverter trip if the temperature reaches 105 °C.

An OH pre-alarm digital output will be switched ON whenever the heatsink temperature reaches the level specified by parameter L8-02 (Overheat pre-alarm level). Parameter L8-03 (Operation selection after overheat pre-alarm) will determine the Inverter's response to reaching the OH pre-alarm level (besides switching the configured digital output).

■ Drive Enabled (Setting: 38)

If a multi-function digital output is programmed to 38 the output is switched ON when the Inverter is enabled. The Inverter can be enabled or disabled using a digital multifunction input (see also [page 6-54](#)).

■ Drive Waiting (Setting: 39)

The digital output will close during the time-out period between the input of a RUN command and the expiring of the delay time specified by b1-11.

■ During oH and Reduced Frequency (Setting: 3A)

If a multi-function digital output is programmed to 3A the output is switched ON when an Inverter overheat alarm has occurred and the motor is running at reduced speed according to parameter L8-19 (Frequency reference during OH pre-alarm). See also [page 6-47](#).

■ RUN Command from Option Card/Communication Option (Setting: 3B)

If a multi-function digital output is programmed to 3B the output will be switched ON when the RUN command is input from the built-in communication (Memobus, N2) OR from a communication option card (SI-S1, SI-N1, etc.). If both RUN commands are off the output will be switched OFF.

■ Cooling Fan Fault (Setting: 3D)

If a multi-function digital output is programmed to 3D the output will be switched ON when the internal cooling fan is faulty. Whenever this output is switched ON the Inverter should be immediately stopped and serviced for internal fan replacement. If the Inverter continues to run in this state, its internal temperature will increase, resulting in a potential decrease of lifetime.

Monitor Parameters

This section explains the analog monitor and pulse monitor parameters.

◆ Using the Analog Monitor Parameters

■ Related Parameters

Parameter Number	Name	Setting Range	Factory Setting	Change during Operation	Access Level
H4-01	Terminal FM monitor selection	1 to 38	2	No	A
H4-02	Terminal FM gain	0 ~ 1000.0%	100%	Yes	A
H4-03	Terminal FM bias	-110.0 ~ +110.0%	0.0%	Yes	A
H4-04	Terminal AM monitor selection	1 to 53	8	No	A
H4-05	Terminal AM gain	0 ~ 1000.0%	50%	Yes	A
H4-06	Terminal AM bias	-110.0 ~ +110.0%	0.0%	Yes	A
H4-07	Terminal FM signal level selection	0 or 2* ¹	0	No	A
H4-08	Terminal AM signal level selection	0 or 2* ¹	0	No	A

*1. An analog output signal of 4-20 mA (setting 2) requires an optional terminal board (ETC618121) for current output.

■ Selecting Analog Monitor Items

Some of the Digital Operator monitor items (U1-□□ [status monitors]) can be output at the multi-function analog output terminals FM-AC and AM-AC. Refer to [page 5-41, Monitor Parameters: U](#), and set the parameter number of U1 group (□□ part of U1-□□) for the parameters H4-01 respectively H4-04.

■ Adjusting the Analog Monitor Items

Adjust the output voltage for multi-function analog output terminals FM-AC and AM-AC using the gain and bias in H4-02, H4-03, H4-05, and H4-06.

The gain sets the analog output voltage value which is equal to 100% of the monitor item.

The bias sets the analog output voltage value which is equal to 0% of the monitor item.

Note that the maximum output voltage is 10V. A voltage higher than this value can not be output.

■ Selecting the Signal Level

Select the signal level for the analog outputs using parameters H4-07 and H4-08. The default setting is 0 to 10V. If a current output signal of 4 to 20mA should be used an optional terminal board (ETC618121) with additional analog current outputs is required.

■ Adjusting the Meter

The influence of the settings of gain and bias on the analog outputs is shown on three examples in [Fig 6.49](#).

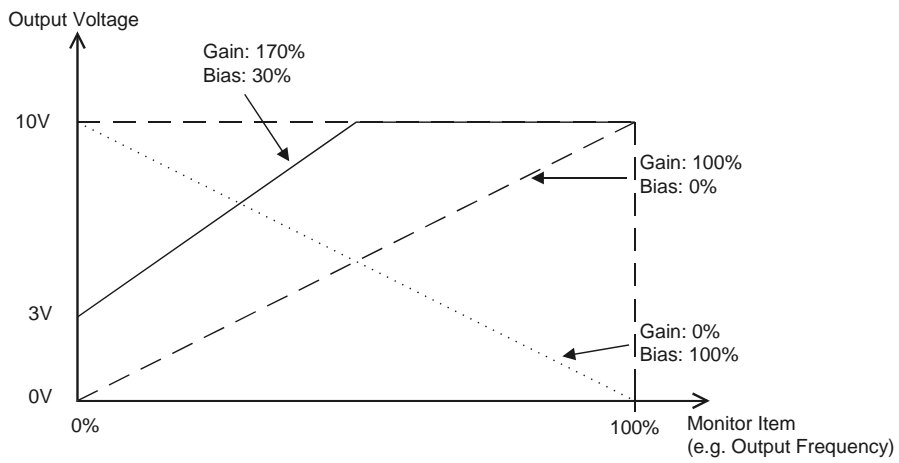

Fig 6.49 Monitor Output Adjustment

Individual Functions

◆ Using MEMOBUS Communications

The Varispeed E7 is equipped with a RS422/485 serial communication port using the MEMOBUS protocol

■ MEMOBUS Communication Configuration

MEMOBUS enables a master device (e.g. PLC) to communicate with up to 31 slave devices (e.g. Inverters). Basically the slaves respond on messages sent from the master.

The master performs serial communications with only one slave at a time. Consequently, to every slave a address must be assigned.

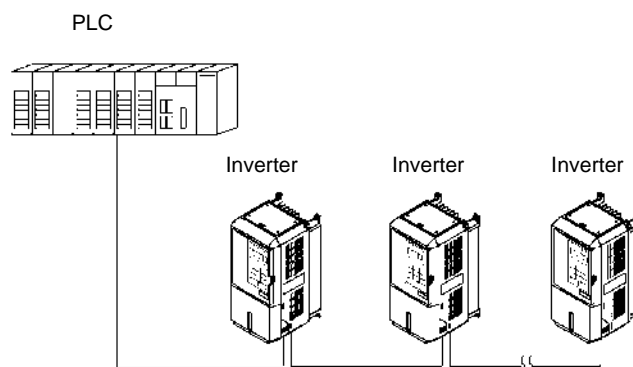

Fig 6.50 Example of Connections between PLC and Inverter

■ Communications Specifications

The MEMOBUS communications specifications are shown in the following table.

Item	Specifications
Interface	RS422, RS485
Communications Cycle	Asynchronous (Start-stop synchronization)
Communications Parameters	Baud rate: Select from 1,200, 2,400, 4,800, 9,600 and 19,200 bps.
	Data length: 8 bits fixed
	Parity: Select from even, odd or none.
	Stop bits: 1 bit selected
Communications Protocol	MEMOBUS
Number of Connectable Units	31 units max.

■ Communications Connection Terminal

The MEMOBUS communication uses the following terminals: S+, S-, R+, and R-. Enable the terminating resistance by turning ON pin 1 of switch S1 for the last Inverter (seen from the PLC) only.

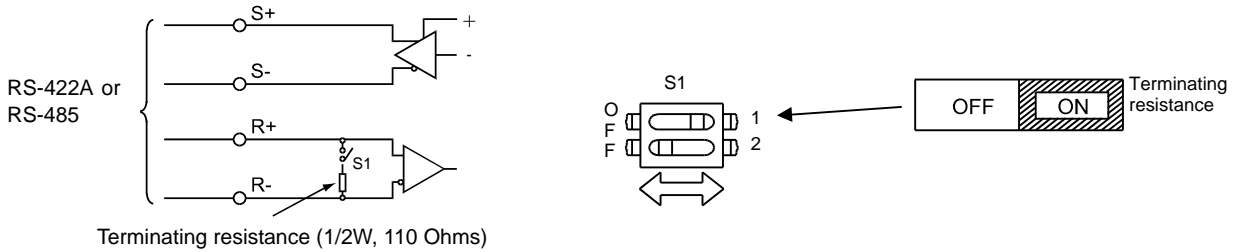

Fig 6.51 Communications Connection Terminal



- Separate the communications cables from the main circuit cables and other wiring and power cables.
- Use shielded cables for the communications cables and use proper shielding clamps
- When using RS485 communication is used, connect S+ to R+, and S- to R-, on the Inverter exterior. See [Fig 6.52](#) below.

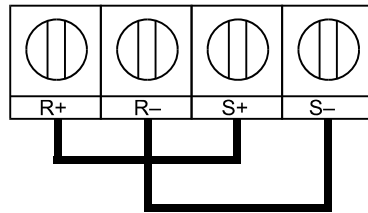

Fig 6.52 Connections when RS485 Communication is used

■ Procedure for Communicating with the PLC

Use the following procedure to perform communications with the PLC.

1. Turn OFF the power supply and connect the communications cable between the PLC and the Inverter.
2. Turn ON the power supply.
3. Set the required communications parameters (H5-01 to H5-08) using the Digital Operator.
4. Turn OFF the power supply and check that the Digital Operator display has completely disappeared.
5. Turn ON the power supply once again.
6. Perform communications with the PLC.



It is absolutely necessary to cycle the input power once when any of the serial communication parameters (H5-01 to H5-09) has been changed.

■ Related Parameters

Parameter Number	Name	Setting Range	Factory Setting	Change during Operation	Access Level
b1-01	Reference source selection	0 to 3	1	No	Q
b1-02	RUN command Source Selection	0 to 3	1	No	Q
H5-01	Station address	0 to 20 ^{*1}	1F	No	A
H5-02	Baud rate selection	0 to 4	3	No	A
H5-03	Communications parity selection	0 to 2	0	No	A
H5-04	Communications error detection selection	0 to 3	3	No	A
H5-05	Communications error detection selection	0 or 1	1	No	A
H5-06	Send wait time	5 to 65 msec	5 msec	No	A
H5-07	RTS control ON/OFF	0 or 1	1	No	A
H5-08	Communication Selection	0 or 1	0	No	A
H5-09	CE detection time	0.0 to 10.0 sec.	2.0 sec.	No	A

*1. Set H5-01 to 0 to disable Inverter responses to MEMOBUS communication

MEMOBUS communications can perform the following operations regardless of the settings in b1-01 and b1-02.

- Monitoring operation status of the inverter
- Setting and reading parameters
- Resetting faults
- Inputting digital input commands. (an OR operation is performed between the commands from MEMOBUS communication and the signals input from multi-function digital input terminals S3 to S7.)

■ Setting RUN Command and Frequency Reference by MEMOBUS

If the RUN command or the frequency reference should be input directly by MEMOBUS communication parameter b1-01 respectively b1-02 have to be set to 3 (Serial communication)

■ MEMOBUS Communication settings

- Parameter H5-02 selects the communication speed. Following speeds are possible: 1200 bps (setting 0), 2400 bps (setting 1), 4800 bps (setting 2), 9600 bps (setting 3, default) and 19200 bps (setting 4).
- Parameter H5-03 selects the used parity between no parity (setting 0, default), even parity (setting 1) and odd parity (setting 2).
- Parameter H5-04 selects the Inverter's behaviour when a communication error (CE) has occurred and H5-05 is set 1. Following settings are possible:
 - 0: Deceleration to stop using deceleration time c1-02, CE fault.
 - 1: Coast to stop, CE fault.
 - 2: Emergency stop using the emergency stop time c1-09, CE fault.
 - 3: Continue operation, CE alarm is displayed.
 Parameter H5-05 selects whether communication error (CE) is detected or not. The default setting is 1, a time out from the master is detected after not receiving any message for the time set in H5-09.
- Parameter H5-06 specifies the delay time the Inverter waits until it sends the response on the received message from the master.
- Parameter H5-07 configures whether the Inverter will implement RTS (Request To Send) messaging all the time (H5-07=0) or only when sending (H5-07=1). It is recommended to set H5-07 to 0 when using RS485 and to 1 when using RS422.

- Beside MEMOBUS the drive is also capable of using Metasys N2 communications via the RS485/422 port. Setting parameter H5-08 to 0 activates MEMOBUS communication, setting 1 enables Metasys N2. Note: A additional manual for the Metasys N2 protocol is available on request.
- The setting of parameter H5-09 determines the length of time that serial communications must be lost before a CE fault occurs.

■Setting Precautions

- If the Inverter trips with CE faults with a communication speed setting of 19200 bps, lower the communication speed.
- If the Inverter trips with CE faults with lower communication speed selections lengthen the send wait time in parameter H5-06
- If the Inverter’s station address is set to 0 it will ignore all messages from the master.

■Message Format

In MEMOBUS communication the master sends commands to the slave and the slave responds. The message format is configured for both sending and receiving as shown below and the length of data packets depends on the command (function) content.

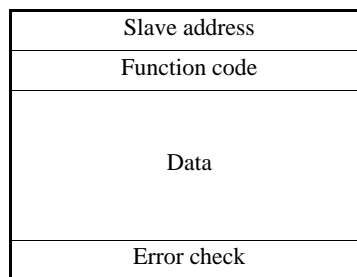

The space between messages must meet the following conditions:

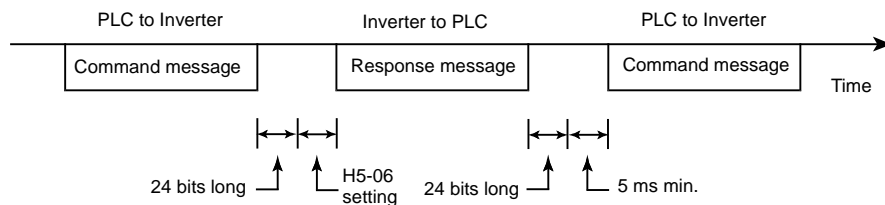

Fig 6.53 Message Spacing

Slave Address

Set the address from 0 to 32. If set to 0, commands from the master will be received by all slaves. (Refer to “Broadcast Data” on the following pages.)

Function Code

The function code specifies commands. The three function codes shown in the table below are available.

Function Code (Hexadecimal)	Function	Command Message		Response Message	
		Min. (Bytes)	Max. (Bytes)	Min. (Bytes)	Max. (Bytes)
03H	Read memory register contents	8	8	7	37
08H	Loopback test	8	8	8	8
10H	Write multiple memory registers	11	41	8	8

Data

Configure consecutive data by combining the memory register address (test code for a loopback address) and the data the register contains. The data length changes depending on the command details.

Error Check

Errors during communications are detected using CRC-16 (cyclic redundancy check, checksum method).

The result of the checksum calculation is stored in a data-word (16 bit), which starting value is FFFFH. The value of this word is manipulated using Exclusive OR- and SHIFT operations together with the data package that should be sent (slave address, function code, data) and the fixed value A001H. At the end of the calculation the data-word contains the checksum value.

The checksum is calculated in the following way:

1. The starting value of the 16 Bit data-word, that is used for the calculation, has to be set to FFFFH.
2. An Exclusive OR operation has to be performed with the starting value and the slave address.
3. The result has to be shifted to the right until the overflow bit becomes 1.
4. When this bit becomes 1, an Exclusive OR operation with the result of step 3 and the fix value A001H has to be performed.
5. After 8 shift operations (every time when the overflow bit becomes 1, an Exclusive OR like in step 4 has to be done), perform an Exclusive OR operation with the result of the former operations and the next data package (8 bit function code). Again the result of this operation has to be shifted 8 times and if needed it has to be interconnected with the fix value A001H using an Exclusive OR operation.
6. The same steps have to be performed with the data, first with the higher byte and then with the lower byte until all data are proceeded.
7. The result of these operations is the checksum. It consists of a high and a low byte.

The following example clarifies the calculation method. It shows the calculation of a CRC-16 code with the slave address 02H (0000 0010) and the function code 03H (0000 0011). The resulting CRC-16 code is 40H for the lower and D1H for the higher byte. The example calculation in this example is not done completely (normally data would follow the function code).

Calculations	Overflow	Description
1111 1111 1111 1111		Initial value
0000 0010		Address
1111 1111 1111 1101		ExOr Result
0111 1111 1111 1110	1	Shift 1
1010 0000 0000 0001		
1101 1111 1111 1111		ExOr Result
0110 1111 1111 1111	1	Shift 2
1010 0000 0000 0001		
1100 1111 1111 1110		ExOr Result
0110 0111 1111 1111	0	Shift 3
0011 0011 1111 1111	1	Shift 4
1010 0000 0000 0001		
1001 0011 1111 1110		ExOr Result
0100 1001 1111 1111	0	Shift 5
0010 0100 1111 1111	1	Shift 6
1010 0000 0000 0001		
1000 0100 1111 1110		ExOr Result
0100 0010 0111 1111	0	Shift 7
0010 0001 0011 1111	1	Shift 8
1010 0000 0000 0001		
1000 0001 0011 1110		ExOr Result
0000 0011		Function Code
1000 0001 0011 1101		ExOr Result
0100 0000 1001 1110	1	Shift 1
1010 0000 0000 0001		
1110 0000 1001 1111		ExOr Result
0111 0000 0100 1111	1	Shift 2
1010 0000 0000 0001		
1101 0000 0100 1110		ExOr Result
0110 1000 0010 0111	0	Shift 3
0011 0100 0001 0011	1	Shift 4
1010 0000 0000 0001		
1001 0100 0001 0010		ExOr Result
0100 1010 0000 1001	0	Shift 5
0010 0101 0000 0100	1	Shift 6
1010 0000 0000 0001		
1000 0101 0000 0101		ExOr Result
0100 0010 1000 0010	1	Shift 7
1010 0000 0000 0001		
1110 0010 1000 0011		ExOr Result
0111 0001 0100 0001	1	Shift 8
1010 0000 0000 0001		
1101 0001 0100 0000		ExOr Result
D1H 40H		CRC-16 Result
Higher Lower		
Byte Byte		

MEMOBUS Message Example

An example of MEMOBUS command/response messages is given below.

Reading Inverter Memory Register Contents

The content of maximum 16 inverter memory registers can be readout at a time.

Among other things the command message must contain the start address of the first register that is to be read out and the quantity of registers that should be read out. The response message will contain the content of the first and the consecutive number of registers that has been set for the quantity.

The contents of the memory register are separated into higher 8 bits and lower 8 bits.

The following tables show message examples when reading status signals, fault details, data link status, and frequency references from the slave 2 Inverter.

Command Message			Response Message (During Normal Operation)			Response Message (During Error)		
Slave Address		02H	Slave Address		02H	Slave Address		02H
Function Code		03H	Function Code		03H	Function Code		83H
Start Address	Higher	00H	Data quantity		08H	Error code		03H
	Lower	20H	1st storage register	Higher	00H	CRC-16	Higher	F1H
Quantity	Higher	00H		Lower	65H		Lower	31H
	Lower	04H	Next storage register	Higher	00H	Next storage register	Higher	00H
Higher		45H		Lower	00H		Lower	00H
CRC-16	Higher	F0H	Next storage register	Higher	01H	Next storage register	Higher	AFH
	Lower	F0H		Lower	F4H		Lower	82H

Loopback Test

The loopback test returns command messages directly as response messages without changing the contents to check the communications between the master and slave. A user-defined test code and data values can be set.

The following table shows a message example when performing a loopback test with the slave no. 1.

Command Message			Response Message (During Normal Operation)			Response Message (During Error)		
Slave address		01H	Slave address		01H	Slave address		01H
Function code		08H	Function code		08H	Function code		89H
Test Code	Higher	00H	Test Code	Higher	00H	Error Code		01H
	Lower	00H		Data	Lower	00H	CRC-16	Higher
Data	Higher	A5H	Data		Higher	A5H		CRC-16
	Lower	37H		CRC-16	Lower	37H		
CRC-16	Higher	DAH	CRC-16		Higher	DAH		
	Lower	8DH		CRC-16	Lower	8DH		

Writing to Multiple Inverter Memory Registers

The writing of inverter memory registers works similar to the reading process, i.e. the address of the first register that is to be written and the quantity of to be written registers must be set in the command message.

The to be written data must be consecutive, starting from the specified address in the command message. The data order must be higher 8 bits, then lower 8 bits. The data must be in memory register address order.

The following table shows an example of a message where a forward operation has been set with a frequency reference of 60.0 Hz for the inverter with the slave address 01H.

Command Message			Response Message (During Normal Operation)			Response Message (During Error)		
Slave Address		01H	Slave Address		01H	Slave Address		01H
Function Code		10H	Function Code		10H	Function Code		90H
Start Address	Higher	00H	Start Address	Higher	00H	Error code		02H
	Lower	01H		Quantity	Lower	01H	CRC-16	Higher
Quantity	Higher	00H	Quantity		Higher	00H		CRC-16
	Lower	02H		CRC-16	Lower	02H		
No. of data		04H	CRC-16		Higher	10H		
Lead data	Higher	00H		CRC-16	Lower	08H		
	Lower	01H						
Next data	Higher	02H						
	Lower	58H						
CRC-16	Higher	63H						
	Lower	39H						

* No. of data = 2 x (quantity)



For the number of data value in the command message the double value of the data quantity must be used.

■ Data Tables

The data tables are shown below. The types of data are as follows: Reference data, monitor data, and broadcast data.

Reference Data

The reference data table is shown below. These data can be read and written. They cannot be used for monitoring functions.

Register No.	Contents		
0000H	Reserved		
0001H	Run operation and input commands		
	Bit 0	Run/stop command	
	Bit 1	Forward/reverse operation	
	Bit 2	External fault	
	Bit 3	Fault reset	
	Bit 4	ComNet	
	Bit 5	ComCtrl	
	Bit 6	Multi-function input command 3	
	Bit 7	Multi-function input command 4	
	Bit 8	Multi-function input command 5	
	Bit 9	Multi-function input command 6	
	Bit A	Multi-function input command 7	
Bits B to F	Not used		
0002H	Frequency reference (Set units using parameter o1-03)		
0003H to 0005H	Not used		
0006H	PI target value		
0007H	Analog output 1 setting (-11 V/-726 to 11 V/726) → 10V = 660		
0008H	Analog output 2 setting (-11 V/-726 to 11 V/726) → 10V = 660		
0009H	Multi-function digital output setting		
	Bit 0	Digital output 1 (Terminal M1-M2) 1: ON 0: OFF	
	Bit 1	Digital output 2 (Terminal M3-M4) 1: ON 0: OFF	
	Bit 2	Not used	
	Bits 3 to 5	Not used	
	Bit 6	Set fault relay (terminal MA-MC) output using bit 7 1: ON 0: OFF	
	Bit 7	Fault relay (terminal MA-MC) 1: ON 0: OFF	
Bits 8 to F	Not used		
000AH to 000EH	Not used		
000FH	Reference selection settings		
	Bit 0	Not used	
	Bit 1	Input PI target value 1: Enabled 0: Disabled	
	Bits 2 to B	Not used	
	C	Broadcast data terminal S5 input 1: Enabled 0: Disabled	
	D	Broadcast data terminal S6 input 1: Enabled 0: Disabled	
	E	Broadcast data terminal S7 input 1: Enabled 0: Disabled	
F	Not used		

Note: Write 0 to all unused bits. Also, do not write data to reserved registers.

Monitor Data

The following table shows the monitor data. Monitor data can only be read.

Register No.	Contents	
0010H	Inverter status signal	
	Bit 0	During run
	Bit 1	Zero speed
	Bit 2	During reverse operation
	Bit 3	Reset signal active
	Bit 4	During speed agree
	Bit 5	Inverter ready
	Bit 6	Minor fault
	Bit 7	Major fault
	Bits 8 to F	Not used
0011H	Operator status	
	Bit 0	During OPE alarm
	Bit 1	During fault
	Bit 2	Operator in programming mode
	Bit 3, 4	00: JVOP-160 attached, 01: JVOP-161 attached, 11: PC connected
Bit 5 to F	Not used	
0012H	OPE Fault Number	
0013H	Not used	
0014H	Fault Content 1	
	Bit 0	PUF, DC bus fuse blown
	Bit 1	UV1
	Bit 2	UV2
	Bit 3	UV3
	Bit 4	Not used
	Bit 5	GF, Ground fault
	Bit 6	OC, Over current
	Bit 7	OV, DC bus over voltage
	Bit 8	OH, Inverter heatsink overheat pre-alarm
	Bit 9	OH1, Inverter heatsink overheat
	Bit A	OL1, Motor overload
	Bit B	OL2, Inverter overload
	Bit C	OL3, Overload detection
Bit D	Not used	
Bit E	Not used	
Bit F	Not used	

Register No.	Contents	
0015H	Fault Content 2	
	Bit 0	EF3, External fault set on terminal S3
	Bit 1	EF4, External fault set on terminal S4
	Bit 2	EF5, External fault set on terminal S5
	Bit 3	EF6, External fault set on terminal S6
	Bit 4	EF7, External fault set on terminal S7
	Bit 5	Not used
	Bit 6	Not used
	Bit 7	Not used
	Bit 8	Not used
	Bit 9	Not used
	Bit A	PF, Input phase loss
	Bit B	LF, Output open phase
	Bit C	OH3, Motor overheat pre-alarm (PTC analog input)
	Bit D	OPR, Digital operator disconnected
Bit E	ERR, EEPROM fault	
Bit F	OH4, Motor overheat (PTC analog input)	
0016H	Fault Content 3	
	Bit 0	CE, Memobus communications error
	Bit 1	BUS, Bus option communications error
	Bit 2/3	Not used
	Bit 4	Not used
	Bit 5	Not used
	Bit 6	EF0, External fault from optional input card
	Bit 7	FBL, PI feedback loss
	Bit 8	LL3, Loss of Load detection
	Bit 9	Not used
	Bit A	OL7, High Slip Braking overload
Bit B to F	Not used	
0017H	CPF Fault Content 1	
	Bit 0/1	Not used
	Bit 2	CPF02
	Bit 3	CPF03
	Bit 4	Not used
	Bit 5	CPF05
	Bit 6	CPF06
Bit 7 to F	Not used	
0018H	CPF Fault Content 2	
	Bit 0	CPF20
	Bit 1	CPF21
	Bit 2	CPF22
	Bit 3	CPF23
Bit 4 to F	Not used	

Register No.	Contents		
0019H	Alarm Content 1		
	Bit 0	UV, DC bus undervoltage	
	Bit 1	OV, DC bus overvoltage	
	Bit 2	OH, Inverter heatsink overheat pre-alarm	
	Bit 3	OH2, Inverter overheat alarm input by a digital input	
	Bit 4	OL3, Overload detection 1	
	Bit 5	Not used	
	Bit 6	EF, Forward/Reverse input set at the same time	
	Bit 7	BB, Baseblock active	
	Bit 8	EF3, External alarm set on terminal S3	
	Bit 9	EF4, External alarm set on terminal S4	
	Bit A	EF5, External alarm set on terminal S5	
	Bit B	EF6, External alarm set on terminal S6	
	Bit C	EF7, External alarm set on terminal S7	
	Bit D/E	Not used	
Bit F	Not used		
001AH	Alarm Content 2		
	Bit 0	Not used	
	Bit 1	Not used	
	Bit 2	OPR, Digital operator disconnected	
	Bit 3	CE, Memobus communications error	
	Bit 4	BUS, Bus option communications error	
	Bit 5	CALL, Communications on standby	
	Bit 6	OL1, Motor overload	
	Bit 7	OL2, Inverter overload	
	Bit 8 to A	Not used	
	Bit B	FBL, PI feedback loss	
	Bit C	CALL, Communications on standby	
	Bit D	UL3, Loss of Load detection	
	Bit E	Not used	
Bit F	Not used		
001BH	Alarm Content 3		
	Bit 0	Not used	
	Bit 1	OH3, Motor overheat pre-alarm	
	Bit 2 to F	Not used	
0020H	Inverter status		
	Bit 0	Forward operation	
	Bit 1	Reverse operation	
	Bit 2	Inverter startup complete	1: Completed 2: Not completed
	Bit 3	Fault	1: Fault
	Bit 4	Data setting error	1: Error
	Bit 5	Multi-function digital output 1 (terminal M1 - M2)	1: ON 0: OFF
	Bit 6	Multi-function digital output 2 (terminal M3 - M4)	1: ON 0: OFF
	Bit 7	Not used	
	Bits 8 to F	Not used	

Register No.	Contents	
0021H	Fault details	
	Bit 0	Overcurrent (OC), Ground fault (GF)
	Bit 1	Main circuit overvoltage (OV)
	Bit 2	Inverter overload (OL2)
	Bit 3	Inverter overheat (OH1, OH2)
	Bit 4	Not used
	Bit 5	Fuse blown (PUF)
	Bit 6	PI feedback lost (FbL)
	Bit 7	External fault (EF, EFO)
	Bit 8	Control board fault (CPF)
	Bit 9	Motor overload (OL1) or Overload (OL3) detected
	Bit A	Not used
	Bit B	Main circuit undervoltage (UV) detected
	Bit C	Main circuit undervoltage (UV1), control power supply fault (UV2), inrush prevention circuit fault (UV3), power loss
	Bit D	Output phase loss (LF)
Bit E	MEMOBUS communications error (CE)	
Bit F	Operator disconnected (OPR)	
0022H	Data link status	
	Bit 0	Writing data
	Bit 1	Not used
	Bit 2	Not used
	Bit 3	Upper and lower limit errors
	Bit 4	Data integrity error
Bits 5 to F	Not used	
0023H	Frequency reference	Monitors U1-01
0024H	Output frequency	Monitors U1-02
0025H	Output voltage	Monitors U1-06
0026H	Output current	Monitors U1-03
0027H	Output power	Monitors U1-08
0028H	Not used	
0029H	Not used	
002AH	Not used	
002BH	Control terminals input status	
	Bit 0	Input terminal S1 1: ON 0: OFF
	Bit 1	Input terminal S2 1: ON 0: OFF
	Bit 2	Multi-function input terminal S3 1: ON 0: OFF
	Bit 3	Multi-function input terminal S4 1: ON 0: OFF
	Bit 4	Multi-function input terminal S5 1: ON 0: OFF
	Bit 5	Multi-function input terminal S6 1: ON 0: OFF
	Bit 6	Multi-function input terminal S7 1: ON 0: OFF
Bits 7 to F	Not used	

Register No.	Contents	
002CH	Inverter status	
	Bit 0	Operation 1: During Operation
	Bit 1	Zero speed 1: Zero speed
	Bit 2	Frequency agree 1: Agreement
	Bit 3	User-defined speed agree 1: Agreement
	Bit 4	Frequency detection 1 1: Output frequency \leq L4-01
	Bit 5	Frequency detection 2 1: Output frequency \geq L4-01
	Bit 6	Inverter startup completed 1: Startup completed
	Bit 7	Undervoltage detection 1: Detected
	Bit 8	Baseblock 1: Inverter output baseblock
	Bit 9	Frequency reference mode 1: By communication option
	Bit A	Run command mode 1: By communication option
	Bit B	Overload detection 1: Detected
	Bit C	Frequency reference lost 1: Lost
	Bit D	Restart enabled 1: Restarting
	Bit E	Fault (including MEMOBUS communications time-out) 1: Fault occurred
Bit F	MEMOBUS communications time-out 1: Timed out	
002DH	Multi-function digital output status	
	Bit 0	Multi-function digital output 1 (terminal M1-M2) 1: ON 0: OFF
	Bit 1	Multi-function digital output 2 (terminal M3-M4) 1: ON 0: OFF
	Bit 2	Not used
	Bits 3 to F	Not used
002EH - 0030H	Not used	
0031H	DC bus voltage	
0032H – 0037H	Not used	
0038H	PI feedback (max. output frequency \triangleq 100%; resolution 0.1%; without sign)	
0039H	PI input (max. output frequency \triangleq 100%; resolution 0.1%; with sign)	
003AH	PI output (max. output frequency \triangleq 100%; resolution 0.1%; with sign)	
003BH	CPU software number	
003CH	Flash software number	
003DH	Communications error details	
	Bit 0	CRC error
	Bit 1	Invalid data length
	Bit 2	Not used
	Bit 3	Parity error
	Bit 4	Overrun error
	Bit 5	Framing error
	Bit 6	Time-out
Bits 7 to F	Not used	
003EH	kVA setting	

Note: Communications error details are stored until a fault reset is input (can also be reset during operation).

Broadcast Data

Using broadcast data a command can be given to all slaves at the same time. The message must be addressed to 00H. All slaves will receive the message, but will not respond.

The following table shows the broadcast data. These data can also be written.

Register Address	Contents	
0001H	Operation signal	
	Bit 0	Run command 1: Operating 0: Stopped
	Bit 1	Reverse operation command 1: Reverse 0: Forward
	Bits 2 and 3	Not used
	Bit 4	External fault 1: Fault
	Bit 5	Fault reset 1: Reset command
	Bits 6 to B	Not used
	Bit C	Multi-function digital input terminal S5 input
	Bit D	Multi-function digital input terminal S6 input
	Bit E	Multi-function digital input terminal S7 input
	Bit F	Not used.
0002H	Frequency reference	

Note: Bit signals not defined in the broadcast operation signals use local node data signals continuously.

■ Inverter Fault Codes

The content of a current fault and faults that have occurred earlier can be read out by Memobus using the Fault Trace (U2-□□) and the Fault History (U3-□□) parameters. The fault codes are shown in the table below.

Fault Code	Fault Description	Fault Code	Fault Description	Fault Code	Fault Description
01H	PUF	13H	EF5	28H	FBL
02H	UV1	14H	EF6	29H	UL3
03H	UV2	15H	EF7	2AH	-
04H	UV3	18H	-	2BH	OL7
06H	GF	19H	-	83H	CPF02
07H	OC	1AH	-	84H	CPF03
08H	OV	1BH	PF	85H	CPF04
09H	OH	1CH	LF	86H	CPF05
0AH	OH1	1DH	OH3	87H	CPF06
0BH	OL1	1EH	OPR	88H	CPF07
0CH	OL2	1FH	ERR	89H	CPF08
0DH	OL3	20H	OH4	8AH	CPF09
0EH	-	21H	CE	8BH	CPF10
0FH	-	22H	BUS	91H	CPF20
10H	-	25H	CF	92H	CPF21
11H	EF3	26H	-	93H	CPF22
12H	EF4	27H	EF0	94H	CPF23

Refer to [Chapter 7, Troubleshooting](#) for detailed fault descriptions and for corrective actions.

■ ENTER Command

When writing parameters to the Inverter from the master using MEMOBUS communications the parameters are temporarily stored in the parameter data area in the Inverter. To enable these parameters the ENTER command must be used.

There are two types of ENTER commands: ENTER commands that enable parameter data in RAM and ENTER commands that write data into the EEPROM (non-volatile memory) in the Inverter at the same time as enabling the data in RAM.

The following table shows the registers used for ENTER commands. The ENTER command is enabled by writing 0 to register number 0900H or 0910H.

Register No.	Contents
0900H	Write parameter data to EEPROM, RAM is refreshed
0910H	Parameter data are not written to EEPROM, but refreshed in RAM only.



The maximum number of times it can be written to EEPROM is 100,000. Do not frequently execute ENTER commands (0900H) that write into EEPROM.

The ENTER command registers are write-only. Consequently, if these registers are read out, the register address will become invalid (Error code: 02H).

■ Communications Error Codes

The following table shows MEMOBUS communications error codes.

Error Code	Contents
01H	Function code error A function code other than 03H, 08H, or 10H has been set by the master.
02H	Invalid register number error <ul style="list-style-type: none"> • The register address can not be accessed. • With broadcast sending, a start address other than 0001H, or 0002H has been set.
03H	Invalid quantity error <ul style="list-style-type: none"> • The quantity of registers being read or written is outside the range of 1 to 16. • In write mode, the number of data in the message is not quantity of registers x 2.
21H	Data setting error <ul style="list-style-type: none"> • A upper limit or lower limit error has occurred in the control data or when writing parameters. • When writing parameters, the parameter setting out of the setting range
22H	Write mode error <ul style="list-style-type: none"> • Attempting to write parameters to the Inverter during operation. • Attempting to send an ENTER command during operation. • Attempting to write parameters other than A1-00 to A1-05, E1-03, or o2-04 when warning alarm CPF03 (defective EEPROM) has occurred. • Attempting to write read-only data.
23H	Writing during DC bus undervoltage (UV) error <ul style="list-style-type: none"> • Writing parameters to the inverter during UV (DC bus undervoltage) alarm. • Sending ENTER commands during UV (DC bus undervoltage) alarm.
24H	Writing error during parameters processing. Attempting to write parameters while other parameters in the Inverter are processed.

■ Slave Not Responding

In the following cases, the slave will ignore the write function.

- When a communications error (overrun, framing, parity, or CRC-16) is detected in the command message.
- When the slave address in the command message and the slave address in the Inverter do not match.
- When the gap between two blocks (8 bit) of a message exceeds 24 bits.
- When the command message data length is invalid.

Application Precautions



If the slave address specified in the command message is 0, all slaves execute the write function, but do not return response messages to the master.

■ Self-Diagnosis

The Inverter has a built-in function for self-diagnosing of the serial communication interface circuits. This function uses the interconnected send/receive terminals and emulates messages.

To perform the self-diagnosis function use the following procedure.

1. Switch ON the Inverter power supply, and set 67 (communications test mode) in parameter H1-05 (Terminal S7 Function Selection).
2. Switch OFF the Inverter power supply.
3. Perform the wiring according to [Fig 6.54](#).
4. Switch ON the terminating resistance. (Turn ON pin 1 on DIP switch 1.)
5. Switch ON the inverter power supply.

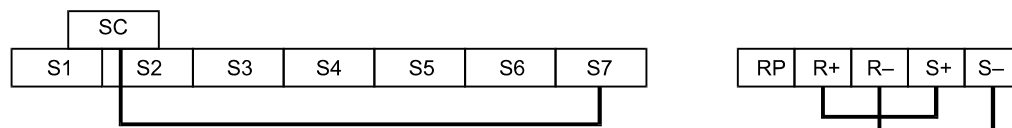

Fig 6.54 Communication Terminals Wiring for Self-Diagnosis

If the serial port is working correctly the Digital Operator displays “PASS” on the display.

If an error occurs, a “CE” (MEMOBUS communications error) alarm will be displayed on the Digital Operator, the fault digital output will be turned ON and the Inverter operation ready signal will be turned OFF.

◆ Using the Timer Function

The digital input and output terminals can be used with a timer function: A digital output is switched ON with a set delay time after a digital input has been switched ON.

■ Related Parameters

Parameter Number	Name	Description	Setting Range	Factory Setting	Change during Operation	Access Level
b4-01	Timer function ON-delay time	Set the timer function output ON delay time (dead time) for the timer function input in 1-second units. Enabled when a timer function is set in H1-□□ and H2-□□.	0.0 to 300.0	0.0 sec.	No	A
b4-02	Timer function OFF-delay time	Set the timer function output OFF delay time (dead time) for the timer function input in 1-second units. Enabled when the timer function is set in H1-□□ and H2-□□.	0.0 to 300.0	0.0 sec.	No	A

Multi-Function Digital Inputs (H1-01 to H1-05)

Set Value	Function
18	Timer function input

Multi-Function Digital Outputs (H2-01 to H2-02)

Set Value	Function
12	Timer function output

■ Setting Example

When the timer function input remains switched ON for a time longer than the setting in b4-01, the timer output function is turned ON. When the timer function input remains switched OFF for a time longer than the setting in b4-02, the timer output function is turned OFF. An example of timer function operation is given in the following diagram.

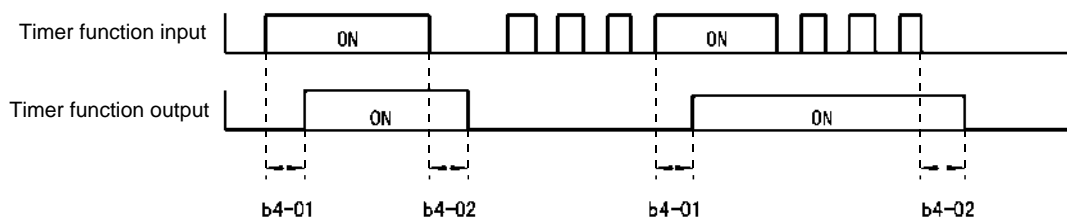

Fig 6.55 Timer Function Operation Example

◆ Using PI Control

PI control is a method of making the feedback value (detection value) match the set target value.

The characteristics of the PI control operations are given below.

- P element** The output of a P-element is proportional to the input (deviation). With using a P-element alone it is not possible to eliminate the deviation completely.
- I element** The output of an I-element is the time-integral of the input (deviation). With using a P-element and an I-element together the deviation can be eliminated completely.

■ PID Control Operation

To understand the differences between the PI control operations P and I the output share of each operation is shown in the following diagram when the deviation (i.e., the difference between the target value and feedback value) is jumps to a certain value (step response).

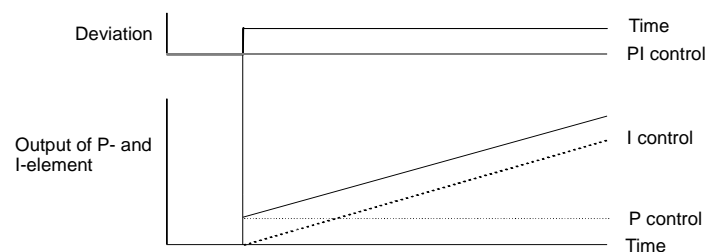

Fig 6.56 PI Control Operation

■ PI Control Applications

The following table shows examples of PI control applications using the Inverter.

Application	Control Details	Example of Sensor Used
Pressure Control	Pressure information is fed back and constant pressure control is performed.	Pressure sensor
Flow Rate Control	Flow rate information is fed back and the flow rate is controlled with high accuracy.	Flow rate sensor
Temperature Control	Temperature information is fed back and a temperature adjustment control using a fan can be performed.	<ul style="list-style-type: none"> • Thermocouple • Thermistor

■ Related Parameters

Parameter Number	Name	Setting Range	Factory Setting	Change during Operation	Access Level
b5-01	PI control mode selection	0, 1, 3	0	No	A
b5-02	Proportional (P) gain	0.00 to 25.00	1.00	Yes	A* ¹
b5-03	Integral (I) time	0.0 to 360.0	1.0 sec.	Yes	A* ¹
b5-04	Integral (I) limit	0.0 to 100.0	100.0%	Yes	A
b5-06	PI limit	0.0 to 100.0	100.0%	Yes	A
b5-07	PI offset	-100.0 to +100.0	0.0%	Yes	A
b5-08	PI delay time constant	0.00 to 10.00	0.00 sec.	Yes	A
b5-09	PI output characteristics selection	0 or 1	0	No	A
b5-10	PI output gain	0.0 to 25.0	1.0	No	A
b5-11	PI reverse output selection	0 or 1	0	No	A
b5-12	Selection of PI feedback signal loss detection	0 to 2	0	No	A
b5-13	PI feedback loss detection level	0 to 100	0%	No	A
b5-14	PI feedback loss detection time	0.0 to 25.5	1.0 sec.	No	A
b5-15	Sleep function operation level	0.0 to 200.0	0.0 Hz	No	A
b5-16	Sleep operation delay time	0.0 to 25.5	0.0 sec.	No	A
b5-17	Accel/decel time for PI reference	0.0 to 25.5	0.0 sec.	No	A
b5-18	PI Setpoint Selection	0 to 1	0	No	A
b5-19	PI Setpoint	0.00 to 100.00	0%	Yes	A
b5-20	PI Setpoint Scaling	0 to 39999	1	No	A
b5-21	Sleep Function Selection	1 to 2	1	No	A
b5-22	Snooze Level	0 to 100	0%	Yes	A
b5-23	Snooze Delay Time	0 to 3600	0 sec.	No	A
b5-24	Wake-Up Level	0 to 100	0%	No	A
b5-25	Setpoint Boost	0 to 100	0%	No	A
b5-26	Maximum Boost Time	0 to 3600	0 sec.	No	A
b5-27	Snooze feedback	0 to 100	60%	No	A
b5-28	PI Feedback Square Root Operation	0 or 1	0	No	A
b5-29	PI Feedback Square Root Gain	0 to 2.00	1.00	No	A
b5-30	PI Output Monitor Square Root	0 or 1	0	No	A
b5-31	PI unit selection	0 to 11	0	No	A

*1. Parameter is moved into Quick Programming Mode when PI controller is enabled, otherwise the parameter is available only in Advanced Programming Mode

Monitor Items (U1-□□)

Parameter Number	Name	Output Signal Level at Analog Output	Unit
U1-24	PI feedback value	10 V: 100% feedback	0.01%
U1-36	PI input volume	10 V: 100% PI input	0.01%
U1-37	PI output volume	10 V: 100% PI output	0.01%
U1-38	PI setpoint	10 V: 100% PI target	0.01%
U1-53	PI feedback 2	10 V: 100% PI feedback	0.01%

Multi-Function Digital Inputs (H1-01 to H1-05)

Set Value	Function
19	PI control disable (ON: PI control disabled)
30	PI control integral reset (ON: integral reset and hold as long as input is ON)
31	PI control integral hold (ON: integral is hold)
34	PI soft starter disable (ON: disabled)
35	PI input characteristics switch

Multi-Function Analog Input (H3-09)

Set Value	Function
B	PI feedback
C	PI target value
16	PI differential feedback

■PI Control Methods

There are two PI control methods. Select the method by setting parameter b5-01.

Set Value	Control Method
0	PI control disabled
1	PI output becomes directly the Inverter output frequency.
3	PI output is added to the frequency reference as compensation value of the Inverter output frequency.

When the PI control is enabled (b5-01=1 or 3) further changes to other parameter settings occur automatically. Following parameters change their Access Level to Quick Access Level:

Parameter Number	Name	Access Level
H3-08	Analog input A2 signal level selection	Q
H3-09	Analog input A2 function selection	Q
H3-13	Terminal A1/A2 switching	Q
b5-31	PI unit selection	Q
b5-02	Proportional (P) gain	Q
b5-03	Integral (I) time	Q

Following parameters change their Default Setting:

Parameter Number	Name	Default Setting
H3-09	Analog input A2 function selection	B

■PI Input Methods

PI Target Value Input Methods

Normally, the frequency reference selected in b1-01 is the PI target value, the PI target value can also be set as shown in the following table.

PI Target Input Method	Setting Conditions
MEMOBUS register 0006H	Set MEMOBUS bit 1 in register address 000FH to 1 (enable/disable PI target value from communications) to be able to use register number 0006H as the PI target value.
Parameter setting	If b5-18 is set to 1 the value in b5-19 becomes the PI target value.



NOTE

If the PI function is used the frequency reference value becomes the target value, which is set and shown in Hz on the operator. Nevertheless, internally the PI target value is used in percent. I.e. the following formula is used:

$$\text{PI target value [\%]} = \frac{\text{frequency reference [Hz]}}{\text{max. output frequency [Hz]}} \cdot 100\%$$

PI Feedback Input Methods

Select one of the following PI control feedback input methods

Input Method	Setting Conditions
Analog input A2	Set H3-09 (Analog Input A2 Function Selection) to B (PI feedback). (Default when PI control is enabled)
Analog input A1 (Differential Mode)	Set H3-09 to 16. Analog input A1 becomes the feedback 1 input and the analog input A2 becomes the feedback 2 input.

If H3-09 is set to 16, the PI differential mode is activated. Both analog inputs (A1 and A2) become feedback inputs and the difference between both ($A1 - A2$) becomes the feedback value for the PI controller. The monitor U1-24 becomes the feedback 1 monitor, U1-53 becomes the feedback 2 monitor.

In PI differential mode the PI target value can be set using parameter b5-07 (PI offset or PI differential set-point).

■PI Adjustment Examples

Suppressing Overshoot

If overshoot occurs, reduce Proportional gain (P), and increase integral time (I).

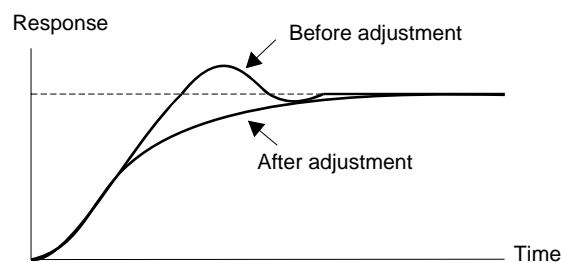

Set a Rapidly Stabilizing Control Condition

To rapidly stabilize the control even if overshoot occurs, reduce integral time (I).

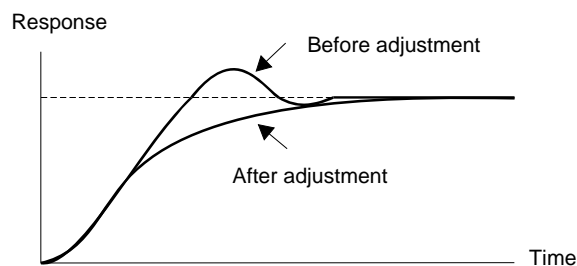

Suppressing Long-cycle Vibration

If vibration occurs with a longer cycle than the integral time (I) set value, lengthen the integral time (I) to suppress the vibration.

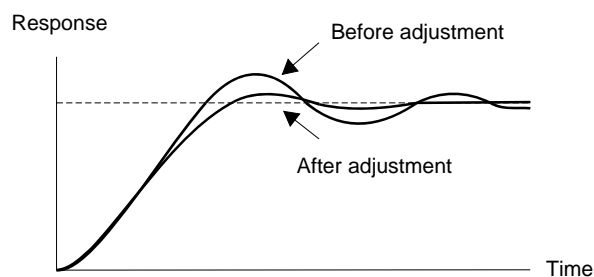

Suppressing Short Cycle Vibration

If short cycle vibration occurs reduce the proportional gain (P), or increase the PI delay time constant.

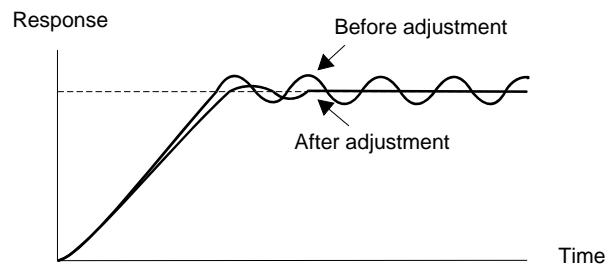

■ Setting Precautions

- Parameter b5-04 is used to prevent the calculated integral value from exceeding a specified amount and so from saturated control. Otherwise, when the load varies rapidly the Inverter response is delayed and the machine might be damaged or the motor may stall. In this case, reduce the set value to speed up Inverter response.
- Parameter b5-06 is used to prevent the output value of the PI control calculation from exceeding a specified amount.
- Parameter b5-07 is used to adjust the PI control offset. It is added to the PI output value. When differential PI feedback is selected (H3-09=16) parameter b5-07 becomes the PI Setpoint it is added to the difference between both feedback values.
- Set the filter time constant for the PI control output in b5-08 to prevent machinery resonance when machinery friction is great or rigidity is poor. In this case, set the constant to a higher value than the resonance frequency oscillation period. Increase this time constant to reduce Inverter responsiveness.
- Parameter b5-09, the PI output polarity can be inverted. If now the PI target value increases the output frequency will be lowered. This function is usable e.g. for vacuum pumps.
- Parameter b5-10 a gain can be applied to the PI control output. Enable this parameter to adjust the amount of compensation if the PI control output is added to the set frequency reference (b5-01 = 3).
- Parameter b5-11 can be used to determine what happens to the inverter output when the PI control output is negative: Setting 0 will limit the PI control output to 0 while setting 1 will allow negative output values. When b1-04 (Prohibition of Reverse Operation) is set to 1 or 3 (revers is disabled), however, the PI output is limited to 0.
- Parameter b5-17 sets an accel./decel. ramp that raises/lowers the PI setpoint gradually (PI soft starter). The normally used accel./decel. function (C1-□□ parameters) is allocated after PI control so that, depending on the settings, resonance with the PI control and hunting in the machinery may occur. Using b5-17 this behaviour can be prevented.
The PI soft starter function can also be disabled or enabled using a digital input (H1-□□ = 34).

PI Control Block

The following diagram shows the PI control block in the Inverter.

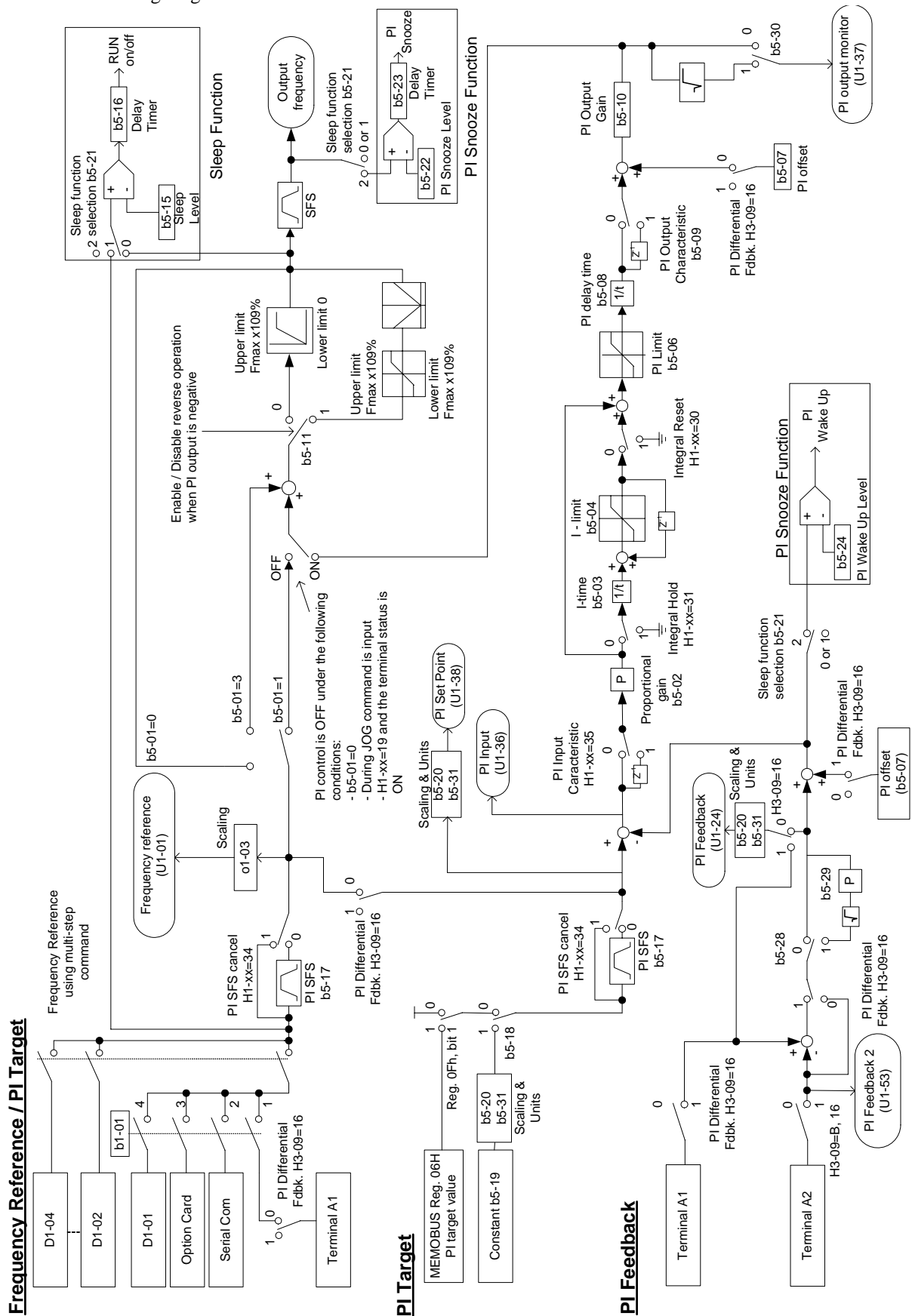

Fig 6.57 PI Control Block Diagram

■PI Feedback Loss Detection

When performing PI control be sure to use the PI feedback loss detection function. Otherwise, when the PI feedback gets lost, the Inverter output frequency may accelerate the motor to the maximum output frequency.

When b5-12 is set to 1 and the PI feedback value falls below the PI feedback loss detection level (b5-13) for a time longer than the PI feedback loss detection time (b5-14) a Fbl alarm (Feedback loss) will be displayed on the Digital Operator display and inverter operation is continued.

When the same happens and b5-12 is set to 2 a Fbl fault will be displayed on the display of the Digital Operator and the inverter operation will be stopped. The motor coasts to stop and the fault relay is operated.

The PI feedback loss function can be disabled by setting b5-12 to 0.

The time chart for PI feedback loss detection is shown below.

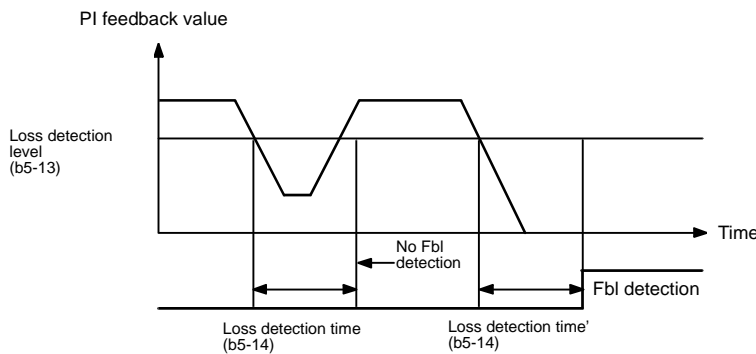

Fig 6.58 PI Feedback Loss Detection Time Chart

■PI Sleep Function

The PI sleep function can be used in two different modes which depends on the setting of b5-21.

If b5-21 is set to 0, the frequency reference/PI target value is the input value for the sleep function. If b5-21 is set to 1, the output frequency before the softstarter (SFS input) is becomes the sleep function input value.

If this value falls below the sleep level b5-15 for a longer time than the sleep operation delay time b5-16, the inverter output will be stopped. If the value comes back to a value higher than b5-15 for a time longer than b5-16, the inverter will resume operation. See also following timing chart.

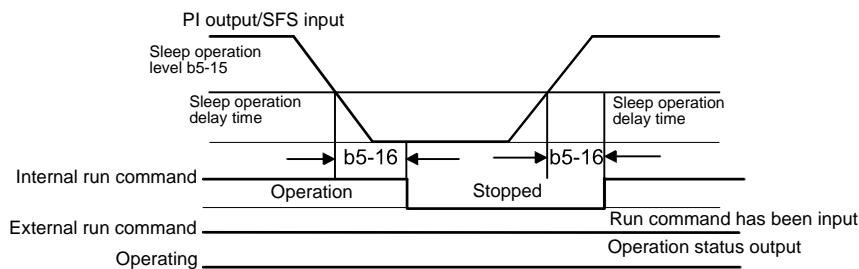

Fig 6.59 PI Sleep Timing Chart

The functionality of the sleep function is also available with deactivated PI controller.

■PI Snooze Function

By setting b5-21 to 2 the PI snooze function can be enabled. This software observes the PI feedback value and the output frequency (Softstarter output) to switch the Inverter ON and OFF automatically as the system requires.

- Snooze Activation

The inverter stops operation when the output frequency (Softstarter output) falls below the snooze level b5-22 for a time longer than the snooze delay time b5-23 and when the feedback value is above the snooze feedback value in b5-27. Before stopping the inverter finally, the PI setpoint can be boosted up to temporarily over-satisfy the load and thereby to avoid a short cycle ON and OFF switching of the inverter. The boost level is set in parameter b5-25 and it is set as percentage of the PI setpoint value, but the maximum time for boost operation is set in b5-26.

- Wake up

The inverter resumes the normal PI operation when the PI feedback falls below the wake up level b5-24. The normal acceleration ramp is used.

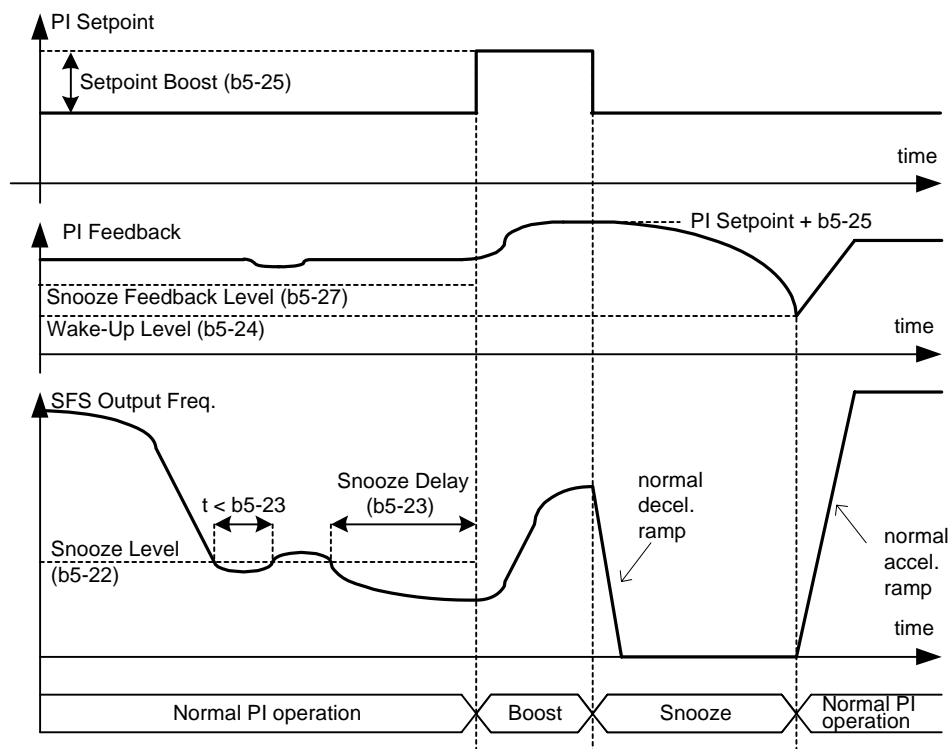

Fig 6.60 PI Snooze Time Chart



NOTE

Using the parameter b5-21 either sleep operation or snooze operation can be enabled. It is impossible to enable both functions at the same time.

■ Square Root Feedback Operation

If parameter b5-28 is set to 1 the feedback value is converted into a value that equals the square root of the actual feedback. This can be used for example to control the flow rate when a pressure sensor is used to generate a feedback value. With parameter b5-29 the square root can be multiplied with a factor. Following formula applies:

$$\text{flow rate} = \text{gain (b5-29)} \times \sqrt{\text{pressure (head)}}$$

So linear connection between the PI target value and the feedback can be realized.

With parameter b5-30 also the feedback monitor can be switched to show a square root value of the actual feedback.

■ Scaling of PI Parameters and Monitors with Units

The PI parameter b5-19 and the monitor parameters U1-24 and U1-38 can be scaled using parameter b5-20. Following setting can be applied:

- 0: 0.01 Hz units (default setting)
- 1: 0.01% (Maximum output frequency is 100%)
- 2 to 39: rotation per minute (rpm) (Sets the motor poles)
- 40 to 39999: User desired display. Sets the maximum setting displayed using the setting rule in *Fig 6.61*

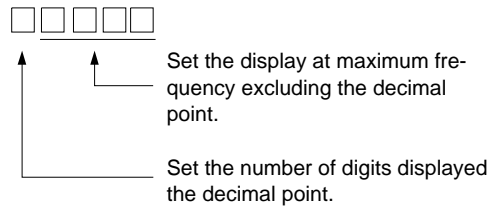

Fig 6.61 PI Scaling Setting Rule

Example: When the max. PI value should be 200.0, set 12000: 2000 for the maximum display and 1 for the one digit behind the decimal point

Additional to the scaling also units can be displayed if a Digital Operator with LCD clear text display is used. The units are defined by parameter b5-31 and following units are available:

Setting Value	Function	Displayed Unit
0	WC: Inch of water column	WC
1	PSI: lb/square inch	PSI
2	GPM: Gallons per minute	GPM
3	F: Degree Fahrenheit	F
4	CFM: Cubic feet per minute	CFM
5	CMH: Cubic meter per hour	CMH
6	LPH: Liters per hour	LPH
7	LPS: Liters per second	LPS
8	Bar: Bar	Bar
9	Pa: Pascal	Pa
10	C: Degree Celsius	C
11	Mtr: Meters	Mtr

■ Multifunction Digital Input Settings: H1-01 to H1-05 (Terminal S3 to S7)

PI Control Disable: 19

- When a multi-function digital input is set for this function it can be used to disable the PI function by switching the input to ON.
- The PI target value becomes the frequency reference value.

PI Control Integral Reset: 30

- Using this function the integral value of the PI control can be reset by setting a multi-function digital input to ON.
- It will remain at 0 as long as the input is ON.

PI Control Integral Hold: 31

- Using this function the integral share value of the PI control can be hold by setting a multi-function digital input to ON. The value will be hold as long as the input is ON.

PI Soft Starter Disable: 34

- To disable the PI soft starter temporarily switch ON the multi-function digital input.

PI Input Characteristic Switch: 35

- Using this function the PI input characteristic can be inverted by switching the multi-function digital input ON.

◆ Energy-saving

When the Energy Saving Function is activated the output voltage is automatically lowered to run the motor at maximum efficiency.

■ Related Parameters

Parameter Number	Name	Setting Range	Factory Setting	Change During Operation	Access Level
b8-01	Energy-saving mode selection	0 or 1	0	No	A
b8-04	Energy-saving coefficient	0.0 to 655.00	*1	No	A
b8-05	Power detection filter time constant	0 to 2000	20 msec	No	A
b8-06	Search operation voltage limiter	0 to 100	0%	No	A

*1. The factory setting depends on the Inverter capacity

■ Adjusting Energy-saving Control

- To enable the energy saving function, set b8-01 (Energy Saving Mode Selection) to 1. The default setting is 0 (disabled).
- b8-04 (Energy-saving Coefficient) is preset assuming that motor and inverter capacity are the same. Adjust b8-04 in steps of 5 % until the output power reaches its minimum. The higher the energy-saving coefficient, the higher is the output voltage.
- To improve the responsiveness when the load fluctuates reduce the power detection filter time constant b8-05. If b8-05 is set too small the motor rotations may become unstable under light load conditions.
- Motor efficiency varies due to temperature fluctuations and differences in motor characteristics. Consequently the motor efficiency has to be controlled. To have optimized efficiency, the search operation varies the output voltage. Parameter b8-06 (Search Operation Voltage Limiter) limits the range for the voltage search operation. For 200 V Class Inverters, a range of 100% is equal to 200 V and for 400 V Class Inverters a range of 100% is equal to 400 V. Set to 0 to disable the search operation voltage limiter.

◆ Setting Motor Parameters

■ Related Parameters

Parameter Number	Name	Setting Range	Factory Setting	Change during Operation	Access Level
E2-01	Motor rated current	0.32 to 6.40 *1	1.90 A *2	No	Q
E2-03	Motor no-load current	0.00 to 1.89 *3	1.2 A *2	No	A
E2-05	Motor line-to-line resistance	0.000 to 65.000	9.842 Ω *2	No	A

*1. The setting range is 10% to 200% of the Inverter rated output current. The value for a 200 V class Inverter of 0.4 kW is given.

*2. The factory setting depends on the Inverter capacity. The value for a 200 V class Inverter of 0.4 kW is given

*3. The setting range is 0.00 A to (E1-01 - 0.01 A).

■ Manual Setting of the Motor Parameter

Motor Rated Current Setting

Set E2-01 to the rated current value on the motor nameplate.

Motor No-Load Current Setting

Parameter E2-03 is measured automatically during motor line-to-line resistance auto-tuning. When auto-tuning can not be performed consult the motor manufacturer for the motor no-load current value.

Motor Line-to-Line Resistance Setting

Parameter E2-05 is measured automatically during motor line-to-line resistance autotuning. When auto-tuning can not be performed, consult the motor manufacturer for the line-to-line resistance value. Calculate the resistance from the line-to-line resistance value in the motor test report using the following formula and then make the setting accordingly.

- E-type insulation: [Line-to line resistance (Ω) at 75°C of test report] × 0.92 (Ω)
- B-type insulation: [Line-to line resistance (Ω) at 75°C of test report] × 0.92 (Ω)
- F-type insulation: [Line-to line resistance (Ω) at 115°C of test report] × 0.87 (Ω)

◆ Setting the V/f Pattern

Using the E1-□□ parameters the Inverter input voltage and the V/f pattern can be set as needed. It is not recommended to change the settings when the motor is used in open loop vector control mode.

■ Related Parameters

Parameter Number	Name	Setting Range	Factory Setting	Change during Operation	Access Level
E1-01	Input voltage setting	155 to 255* ¹	200 V* ¹	No	Q
E1-03	V/f pattern selection	0 to F, FF	F	No	A
E1-04	Max. output frequency (FMAX)	0.0 to 200.0	50.0 Hz	No	A
E1-05	Max. output voltage (VMAX)	0.0 to 255.0* ¹	200.0 V* ¹	No	A
E1-06	Base frequency (FA)	0.0 to 200.0	50.0 Hz	No	A
E1-07	Mid. output frequency (FB)	0.0 to 200.0	2.5 Hz	No	A
E1-08	Mid. output frequency voltage (VB)	0.0 to 255* ¹	15.0 V* ¹	No	A
E1-09	Min. output frequency (FMIN)	0.0 to 200.0	1.2 Hz	No	A
E1-10	Min. output frequency voltage (VMIN)	0.0 to 255.0* ¹	9.0 V* ¹	No	A
E1-11	Mid. output frequency 2	0.0 to 200.0	0.0 Hz* ²	No	A
E1-12	Mid. output frequency voltage 2	0.0 to 255.0* ¹	0.0 V* ²	No	A
E1-13	Base voltage (VBASE)	0.0 to 255.0* ¹	0.0 V	No	A

*1. Values for 200 V class Inverters are shown. For a 400 V class Inverter the values have to be doubled.

*2. Parameters E1-11 and E1-12 are disabled when set to 0.0

■ Setting Inverter Input Voltage

Set the Inverter input voltage correctly in E1-01 so that it matches the power supply voltage. The set value becomes a reference value for the stall prevention during deceleration and the overvoltage level according to the table below.

Inverter Voltage Class	Input Voltage Setting E1-01	OV Level	Stall Prevention during Decel Level
200 V	200 V	410 VDC	377 VDC
400 V	≤ 400 V	720 VDC	662 VDC
	≥ 400 V	820 VDC	754 VDC

■ Setting V/f Pattern

The V/f pattern can be selected using parameter E1-03. There are two methods of setting the V/f pattern: Select one of the 15 preset pattern types (set value: 0 to E), or set a user-defined V/f pattern (set value: F).

The factory setting for E1-03 is F.

To select one of the existing patterns, refer to the following table.

Characteristic	Application	Set Value	Specifications
Constant Torque Characteristic	These patterns are used in general applications where the load torque is fixed, regardless of rotation speed, e.g. for linear transport systems.	0 (F)	50 Hz specifications
		1	60 Hz specifications
		2	60 Hz specifications, voltage saturation at 50 Hz
		3	72 Hz specifications, voltage saturation at 60 Hz
Variable torque characteristic	These patterns are used for loads with torque proportional to the square or cube of the rotation speed, such as fans and pumps.	4	50 Hz specifications, cubical torque characteristic
		5	50 Hz specifications, quadratic torque characteristic
		6	60 Hz specifications, cubical torque characteristic
		7	60 Hz specifications, quadratic torque characteristic
High Startup Torque *1	Select a high startup torque V/f pattern only in the following cases. <ul style="list-style-type: none"> • The wiring distance between Inverter and motor is large (approx. 150 m min.) • A large torque is required at startup • An AC reactor is inserted in the Inverter input or output. 	8	50 Hz specifications, medium startup torque
		9	50 Hz specifications, large startup torque
		A	60 Hz specifications, medium startup torque
		B	60 Hz specifications, large startup torque
Field Weakening Operation	This pattern is used for frequencies of 60 Hz or higher. From the voltage saturation point on (in the field weakening area) the output voltage is fixed to the maximum output voltage.	C	90 Hz specifications, voltage saturation at 60 Hz
		D	120 Hz specifications, voltage saturation at 60 Hz
		E	180 Hz specifications, voltage saturation at 60 Hz
Without Limits	With this pattern the voltage and frequency values can be set to any desired value, without limitations.	FF	50 Hz specifications, without parameter limits.

*1. Usually sufficient starting torque is provided by the torque compensation function (automatic torque boost at low speed)

When one of these patterns is selected the values of parameters E1-04 to E1-10 are changed automatically. There are three different sets of values for E1-04 to E1-10, depending on the Inverter capacity.

- 0.4 to 1.5 kW V/f pattern
- 2.2 to 45 kW V/f pattern
- 55 to 300 kW V/f pattern

The characteristics diagrams for each are shown in the following pages.

0.4 to 1.5 kW V/f Pattern

The diagrams show characteristics for a 200 V class Inverter. For a 400 V class Inverter, multiply all voltages with 2.

- Constant Torque Characteristics (Set Value: 0 to 3)

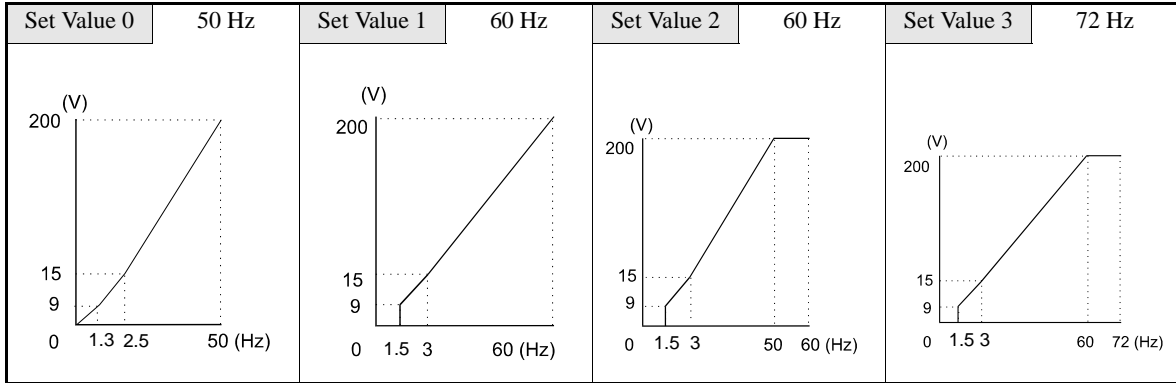

- Variable Torque Characteristics (Set Value: 4 to 7)

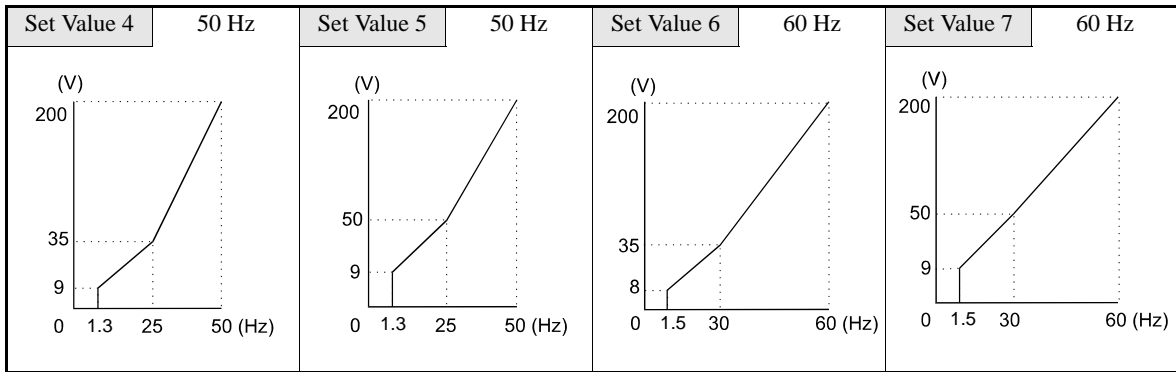

- High startup torque (Set value 8: to B)

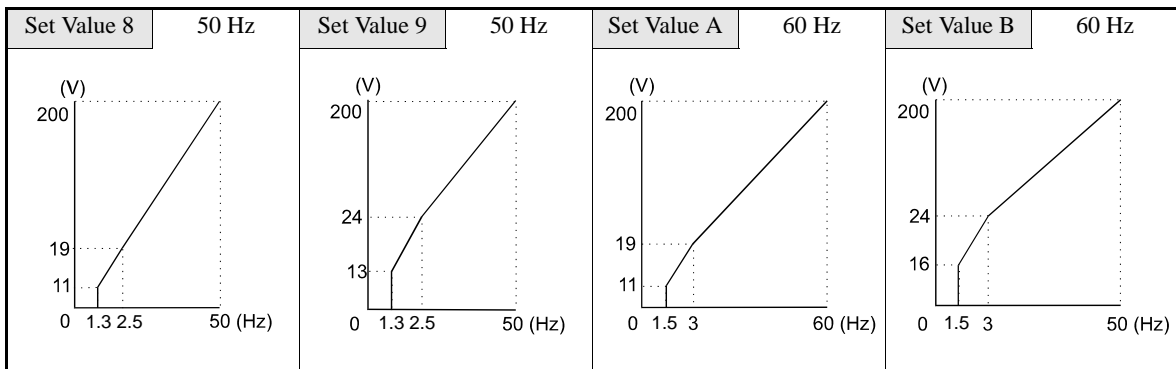

- Field Weakening Operation (Set Value: C to E)

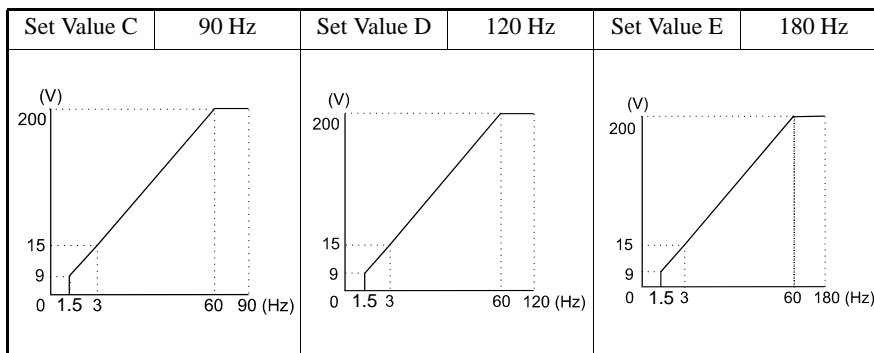

2.2 to 45 kW V/f Pattern

The diagrams show characteristics for a 200 V class Inverter. For a 400 V class Inverter, multiply all voltages with 2.

- Constant Torque Characteristics (Set Value: 0 to 3)

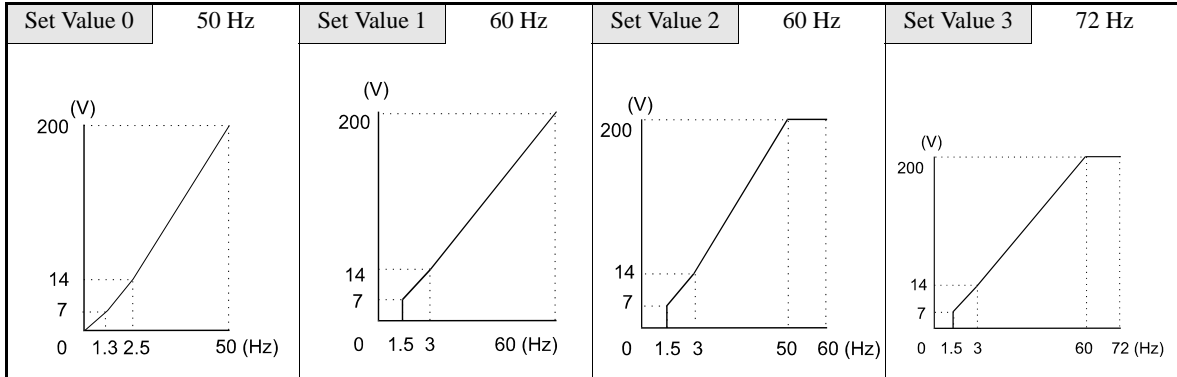

- Variable Torque Characteristics (Set Value: 4 to 7)

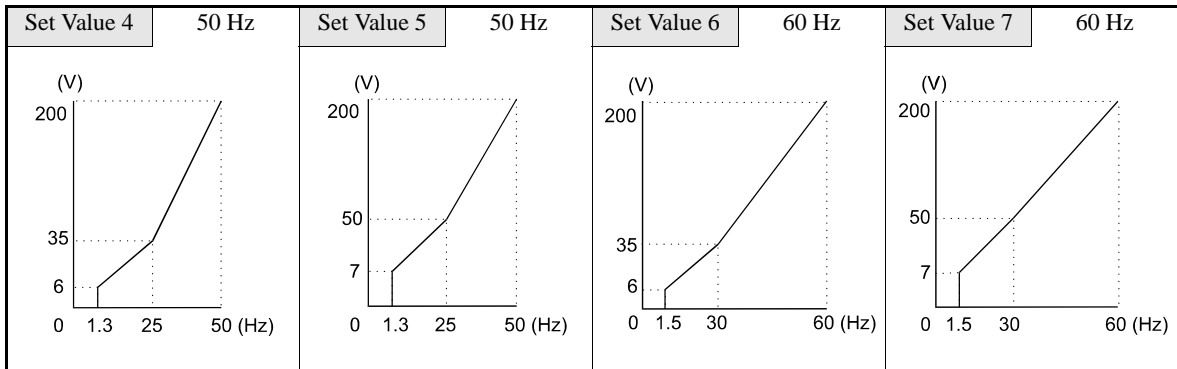

- High Startup Torque (Set Value: 8 to B)

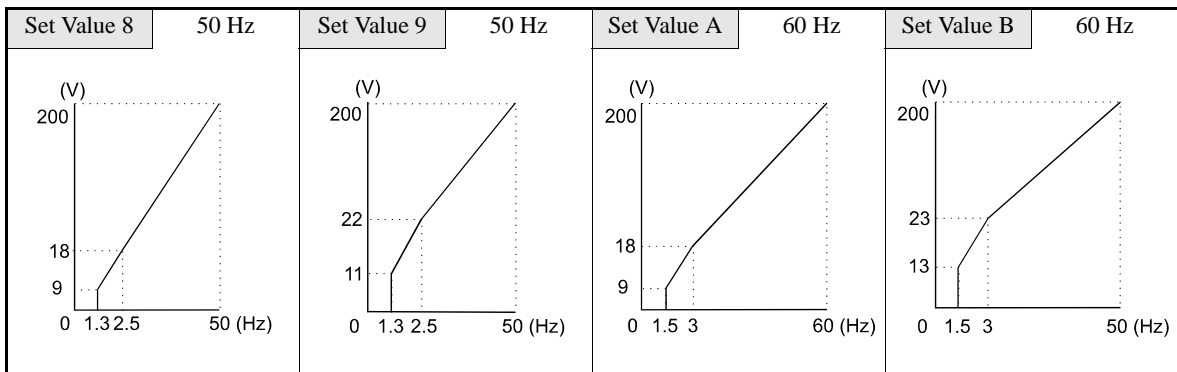

- Field Weakening Operation (Set Value: C to E)

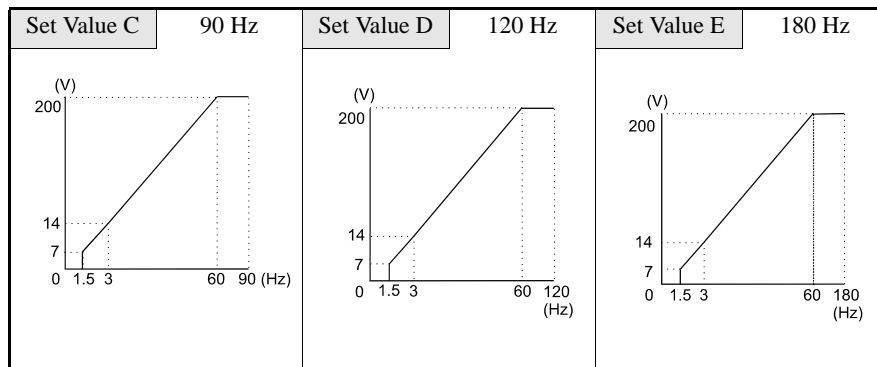

55 to 300 kW V/f Pattern

The diagrams show characteristics for a 200 V class Inverter. For a 400 V class Inverter, multiply all voltages with 2.

- Constant Torque Characteristics (Set Value: 0 to 3)

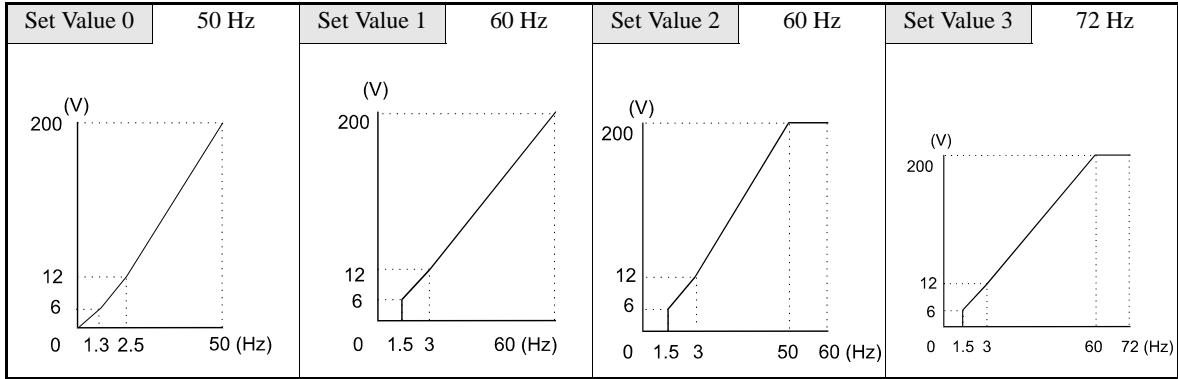

- Variable Torque Characteristics (Set Value: 4 to 7)

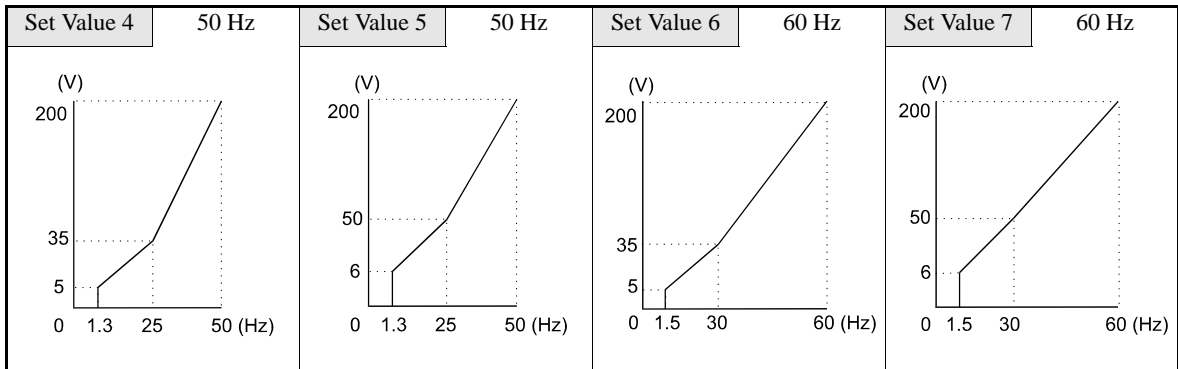

- High Startup Torque (Set Value: 8 to B)

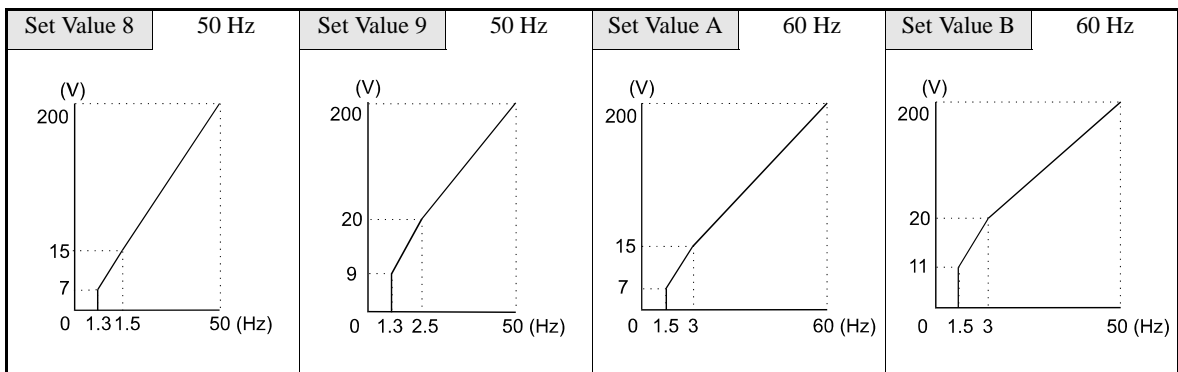

- Field Weakening Operation (Set Value: C to E)

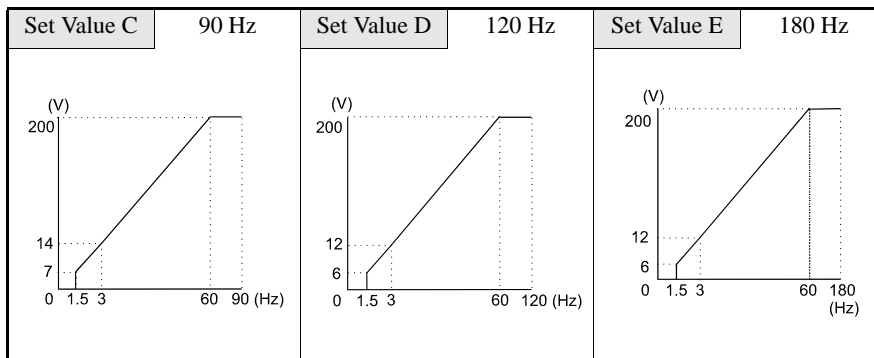



NOTE

When E1-03 is set to F (User-defined V/f pattern) parameters E1-04 to E1-10 can be set. If E1-03 is set to anything other than F, parameters E1-04 to E1-13 can only be read. If the V/f characteristics are linear, set E1-07 and E1-09 to the same value. In this case, E1-08 will be ignored.

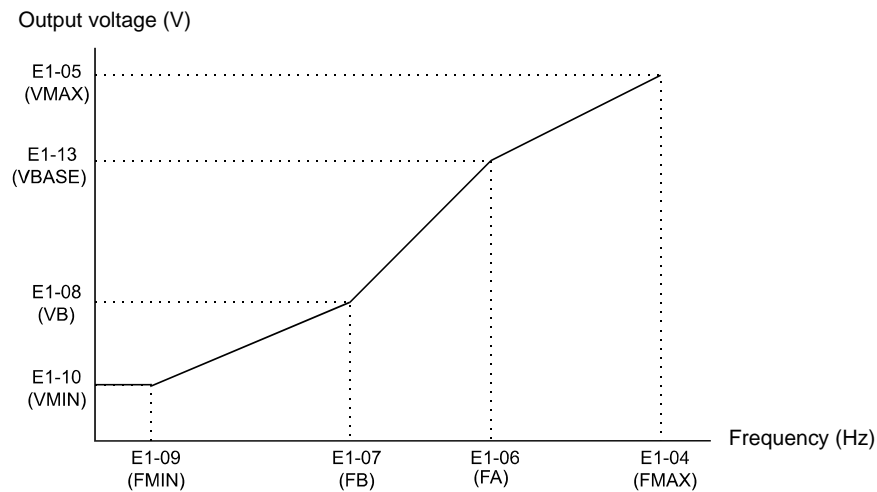

Fig 6.62 User-Set V/f Pattern

■ Setting Precautions

When the setting is to user-defined V/f pattern, beware of the following points:

- Parameters E1-11 and E1-12 are set to 0.0 by default in all V/f patterns. If E1-03 is set to F they can be set to obtain another point defining the V/f pattern.
- Be sure to set the four frequencies as follows:
 $E1-04 (FMAX) \geq E1-11 (FMID2) > E1-06 (FA) > E1-07 (FB) \geq E1-09 (FMIN)$

◆ Motor Preheat Function

The motor preheat function can be used to prevent e.g. moisture inside the motor due to condensation. Two different current levels are available. The preheat currents can be set in parameters b2-09 and b2-10 as a percentage of the Inverter rated current. Both functions are enabled by digital inputs. If the Drive Enable (H1-□□=6A) or Bypass Drive Enable (H1-□□=70) function is used the motor preheat function 2 has to be used, the preheat function 2 can then also be activated without enabling the drive.

■ Related Parameters

Parameter Number	Name	Setting Range	Factory Setting	Change during Operation	Access Level
b2-09	Motor preheat current 1	0 to 100	0%	No	A
b2-10	Motor preheat current 2	0 to 10	5%	No	A

■ Multi-function Digital Inputs (H1-01 to H1-05)

Set value	Function
60	Motor preheat 1
80	Motor preheat 2

The time chart for motor preheat is shown below.

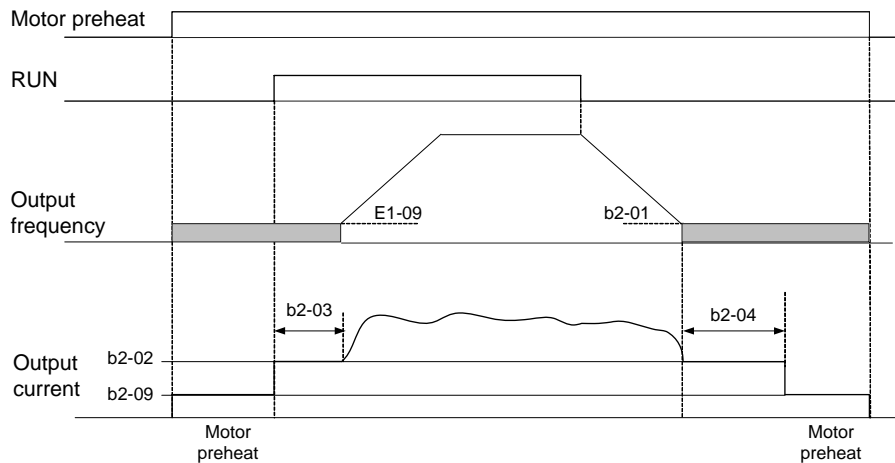

Fig 6.63 Motor Preheat Function 1 Time Chart

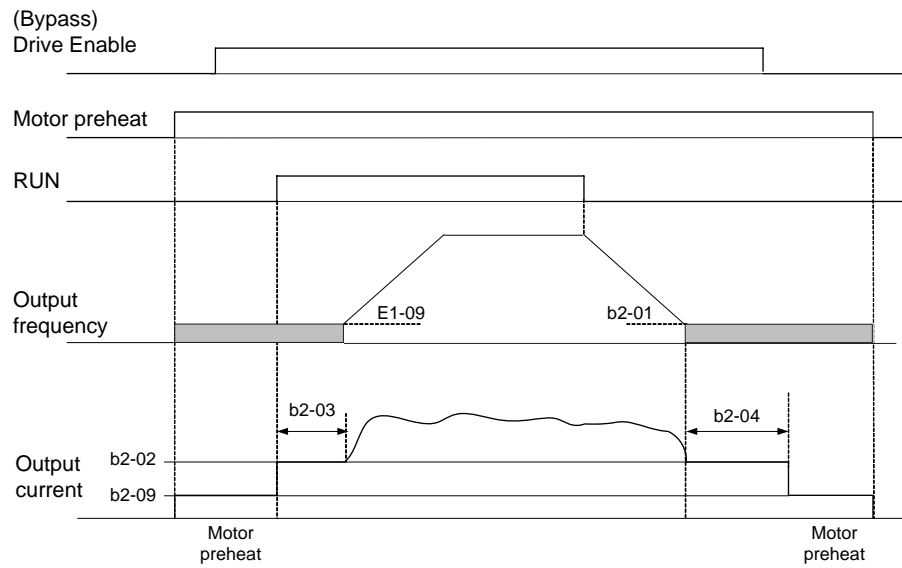

Fig 6.64 Motor Preheat Function 2 Time Chart

Setting Precautions

- If the Motor Preheat command 1 and the Motor Preheat Command 2 are set simultaneously an OPE3 alarm will occur.
- If Motor Preheat command 1 and Drive Enable or Bypass Drive Enable are set simultaneously an OPE3 alarm will occur. Motor Preheat 2 has to be used instead.
- During motor preheat operation the Digital Operator display will show PRHT alarm.

◆ Emergency Override Function

The emergency override function is used as a “smoke purge function. It will run the motor at the preset emergency override speed or at AUTO frequency reference in forward or reverse direction. See Fig for a timing chart.

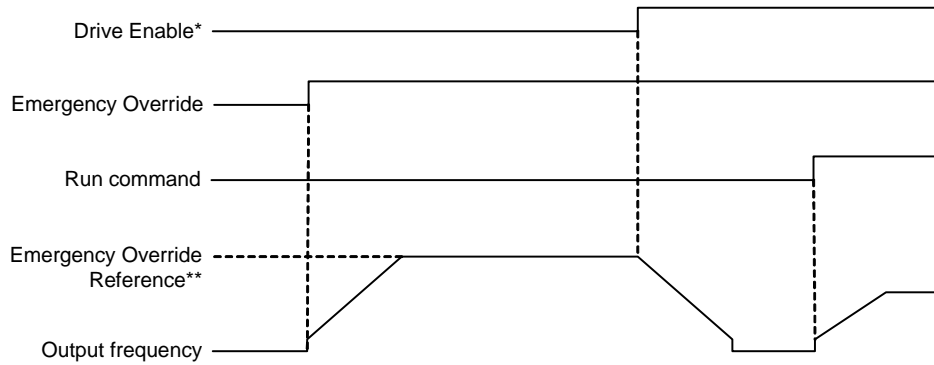

* Applies for Drive Enable (H1-xx=6A) or Bypass Drive Enable (H1-xx=70)

** Either b1-14 or AUTO reference, depending on b1-15 setting

Fig 6.65 Timing Chart for Emergency Override Function

■ Related Parameters

Parameter Number	Name	Setting Range	Factory Setting	Change during Operation	Access Level
b1-14	Emergency override speed	0 to 200.00	0.00 Hz	No	A
b1-15	Emergency override reference selection	0 or 1	0	No	A

Multi-Function Digital Inputs (H1-01 to H1-05)

Set Value	Function
81	Emergency override forward (ON: Emergency override in forward direction)
82	Emergency override reverse (ON Emergency in override in reverse direction)

■ Setting and Application Precautions

- An OPE3 alarm will occur when emergency override forward and emergency override reverse are programmed to digital inputs simultaneously.
- During emergency override the Digital Operator display will show OVRD alarm.
- When the HOA Digital Operator is used, the OFF key is disabled during Emergency Override if any of the multi-function inputs are programmed to Drive Enable (H1-xx=6A) or Bypass Drive Enable (H1-xx=70), in both HAND and AUTO Mode.
- If a RUN or jog input is closed but the Drive Enable / Bypass Drive Enabled input is open, the Inverter will display a “DNE Drive not Enable” alarm and the STOP LED will blink. When the Emergency Override input is closed, the alarm display will change to “OVRD Emergency Override”, the RUN LED will turn ON and the STOP LED will turn OFF again.

◆ High Slip Braking

The High Slip Braking function can shorten the deceleration times without using a braking option for emergency stops for example.

The function must be activated by a multifunction digital input.

Note the following:

- The HSB function is not comparable with the normal deceleration function. It does not use a ramp function.
- HSB should not be used at normal operation instead of a deceleration ramp.

■ Related Parameters

Parameter Number	Name	Setting Range	Factory Setting	Change during Operation	Access Level
n3-01	High Slip braking deceleration frequency width	1 to 20	5%	No	A
n3-02	High Slip braking current limit	100 to 200	150%	No	A
n3-03	High Slip braking stop dwell time	0.0 to 10.0	1.0 sec.	No	A
n3-04	High Slip braking OL7 time	30 to 1200	40 sec.	No	A

Adjusting the HSB Deceleration Frequency Width (N3-01)

This parameter sets the step value (in percent of maximum output frequency) that is used for lowering the output frequency to achieve a large negative slip and thereby to brake the motor.

Normally no adjustments should be necessary. Increase the value if DC bus overvoltage faults occur.

Adjusting the HSB Current Limit (N3-02)

The setting of parameter N3-02 limits the output current while high slip braking is active. The current limit affects the achievable deceleration time. The parameter is set in percent of the motor rated current setting.

The lower the current limit the longer is the deceleration time.

Setting the HSB Dwell Time at Stop (N3-03)

At the end of a high slip braking the output frequency is held at the minimum output frequency for the time set in N3-03. Increase the time if the motor coasts after HSB.

Setting the HSB Overload Time (N3-04)

N3-04 sets the HSB overload time. If the output frequency does not change for any reason although an HSB command is given, an OL7 fault will be displayed and the fault relay will operate.

Activating High Slip Braking

If one of the multifunction inputs is set to “68” it can be used to activate the HSB function. The Inverter will brake the motor immediately after the HSB command was given. As the HSB function is activated by the positive edge of digital input signal HSB cannot be stopped, i.e. normal inverter operation cannot be resumed.

Digital Operator Functions

◆ Setting Digital Operator Functions

■ Related Parameters

Parameter Number	Name	Setting Range	Factory Setting	Change during Operation	Access Level
o1-01	Monitor selection *1	6 to 53	6	Yes	A
o1-02	Monitor selection after power up	1 to 4	1	Yes	A
o1-03	Digital operator display scaling	0 to 39999	0	No	A
o1-09	Frequency reference display unit selection *2	0 to 11	0	No	A
o2-01	LOCAL/REMOTE key enable/disable *3	0 or 1	1	No	A
o2-02	STOP key during control circuit terminal operation *3	0 or 1	1	No	A
o2-03	User parameter initial value	0 to 2	0	No	A
o2-05	Frequency reference setting method selection	0 or 1	0	No	A
o2-06	Operation selection when digital operator is disconnected	0 or 1	0	No	A
o2-07	Cumulative operation time setting	0 to 65535	0 hrs	No	A
o2-08	Cumulative operation time selection	0 or 1	0	No	A
o2-09	Initialize Mode	1 to 5	2	No	A
o2-10	Fan operation time setting	0 to 65535	0 hr.	No	A
o2-12	Fault trace initialize	0 or 1	0	No	A
o2-14	kWh monitor initialize	0 or 1	0	No	A
o2-15	HAND Key function selection *4	0 or 1	0	No	A

*1. This parameter is effective only when the LED Digital Operator is used.

*2. Parameter function is only valid if a Digital Operator with LCD clear text display is used (LCD or HOA Digital Operator).

*3. This parameter is effective only when the LED or LCD Digital Operator is used.

*4. This parameter is effective only when the HOA operator JVOP-162 is used

■ Monitor Selection (o1-01)

Using parameter o1-01 the third monitor item that is directly displayed in Drive Mode can be selected. This parameter is only effective when the LED Digital Operator is used.

■ Monitor Display when the Power Supply is Turned ON (o1-02)

Using parameter o1-02 the monitor item (U1-□□) that is displayed on the Digital Operator when the power supply is turned ON can be selected.

■ Changing Frequency Reference Scaling (o1-03)

The frequency monitors can be scaled using parameter o1-03. The scaling will be applied to following monitor items and parameters:

- U1-01 (Frequency reference)
- U1-02 (Output frequency)
- U1-05 (Motor speed)
- U1-20 (Output frequency after soft starter)
- d1-01 to d1-04 and d1-17 (Frequency references)

The following scaling settings can be applied:

0: 0.01 Hz units (default setting)

1: 0.01% (Maximum output frequency is 100%)

2 to 39: rotation per minute (rpm) (Sets the motor poles)

40 to 39999: User desired display. Sets the maximum setting displayed using the setting rule in [Fig 6.66](#)

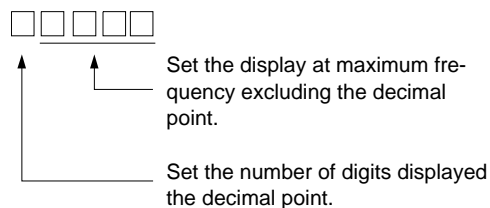

Fig 6.66 Frequency Scaling Setting Rule

Example: When the max. output frequency value should be 200.0, set 12000: 2000 for the maximum display and 1 for the one digit behind the decimal point

■ Changing Frequency Reference Display Units (o1-09)

Additional to the scaling also units can be displayed if a Digital Operator with LCD clear text display is used.

The units are defined by parameter o1-09 and following units are available:

Setting Value	Function	Displayed Unit
0	WC: Inch of water column	WC
1	PSI: lb/square inch	PSI
2	GPM: Gallons per minute	GPM
3	F: Degree Fahrenheit	F
4	CFM: Cubic feet per minute	CFM
5	CMH: Cubic meter per hour	CMH
6	LPH: Liters per hour	LPH
7	LPS: Liters per second	LPS
8	Bar: Bar	Bar
9	Pa: Pascal	Pa
10	C: Degree Celsius	C
11	Mtr: Meters	Mtr

■ Disabling the LOCAL/REMOTE Key (o2-01)

Set o2-01 to 0 to disable the LOCAL/REMOTE Key on the LED or LCD Digital Operator.

If the key is disabled, it cannot be used anymore to switch over the frequency reference source or the RUN command source between Digital Operator and the settings in b1-01 and b1-02.

■ Disabling the STOP Key (o2-02)

This parameter is used to set whether the STOP key on the LED or LCD Digital Operator is active during remote control (b1-02 ≠ 0) or not.

If o2-02 is set to 1 a STOP command from the operators STOP key will be accepted, the Inverter will stop according to the method set in parameter b1-03 (Stopping method). If o2-02 is set to 0 it will be disregarded.

■ Initializing Changed Parameter Values (o2-03)

The current Inverter parameter setting values can be saved as user-set parameter values. Therefore parameter o2-03 has to be set to 1.

To initialize the Inverter parameters using the user-set initial values in memory parameter A1-03 has to be set to 1110. To clear the user-set initial values in memory set o2-03 to 2.

■ Setting the Frequency Reference using the UP and DOWN Keys without Using the Enter Key (o2-05)

This function is active when the frequency reference is input from any Digital Operator. When o2-05 is set to 1 and the frequency reference is input via any Digital Operator the reference can be incremented or decremented using the UP and DOWN keys directly, pressing the ENTER button is not necessary.

■ Operation Selection when the Digital Operator is Disconnected (o2-06)

Parameter o2-06 selects whether a fault is detected when the Digital Operator is disconnected from the Inverter.

If o2-06 is set to 0 the operation is continued.

If o2-06 is set to 1 the output is switched off and the motor coasts to stop, the fault relay is operated and the Digital Operator Display shows an OPR fault when reconnected.

■ Cumulative Operation Time (o2-07 and o2-08)

The Inverter counts its operation time cumulatively.

Using parameter o2-07 the cumulative operation time can be changed, e.g. after a replacement of the control board. If parameter o2-08 is set to 0 the inverter counts the time whenever the power supply is switched ON. If o2-08 is set to 1 the time when a RUN command is active is counted only. The factory setting is 1.

■ Cooling Fan Operation Time (o2-10)

This function counts the operating time of the inverter mounted fan cumulatively.

Using parameter o2-10 the counter can be reset, e.g. when the fan was replaced.

■ Fault Trace Initialize (o2-12)

This function can be used to initialize the fault trace by setting parameter o2-12 to 1. All previously stored faults are deleted.

■ Energy Monitor Initialize (o2-14)

This function can be used to initialize the energy monitor by setting parameter o2-14 to 1.

■ HAND Key Function Selection (o2-15)

With this parameter the HAND key can be enabled by setting parameter o2-15 to 1. The factory setting is 0, HAND key disabled. The parameter is effective only, if the optional HOA Digital Operator is used.

■ Standard / IP54 Selection (o2-17)

This parameter selects whether the Inverter is of protection class IP00 / NEMA 1 / IP20 (setting 0) or IP54 (setting 1). Whenever an Inverter in protection IP54 class is used o2-17 has to be set to 1. This switches the carrier frequency and temperature limit parameters to appropriate values.

◆ Copying Parameters

The Digital Operator can perform the following three functions using a built-in EEPROM

- Store 1 Inverter parameter set in the Digital Operator (READ)
- Write 1 Inverter parameter set from the Digital Operator to the Inverter (COPY)
- Compare 1 Inverter parameter set stored in the Digital Operator with the Inverter parameters settings (VERIFY)

■ Related Parameters

Parameter Number	Name	Description	Setting Range	Factory Setting	Change during Operation	Access Level
o3-01	Copy function selection	0: Normal operation 1: READ (Inverter to Operator) 2: COPY (Operator to Inverter) 3: Verify (compare)	0 to 3	0	No	A
o3-02	Read permitted selection	0: READ prohibited 1: READ permitted	0 or 1	0	No	A

Refer to the following pages for the procedures for using the copy function.

■ Storing Inverter set values in the Digital Operator (READ)

To store Inverter set values in the Digital Operator use the following method.

Step No.	Digital Operator Display		Explanation
	LED Digital Operator	LCD/HOA Digital Operator	
1			Press the MENU key until the Advanced Programming Mode is reached.
2			Press the DATA/ENTER key to enter the Function Selection Display in Advanced Programming Mode.
3			Scroll to parameter o3-01 (Copy Function Selection) using the Increment key and Decrement key.
4			Press the DATA/ENTER key to enter the Parameter Setting Display.
5			Change the set value to 1 using the Increment key.
6			Press the DATA/ENTER key. The READ function will start.
7			When the READ function is completed "End" respectively "Read Complete" is displayed on the Digital Operator for appr. 1 second. Then the display returns to the Monitor Display and parameter o1-03 is automatically reset to 0.

If a fault is displayed press any key to clear the fault display and return to the o3-01 display. Fault displays and their meanings are shown below.







Select READ Prohibited

This function prevents overwriting of the data that are stored in the EEPROM of the Digital Operator. When o3-02 is set to 0 and o3-01 is set to 1 to perform a write operation PrE will be displayed on the Digital Operator and the write operation will be stopped.

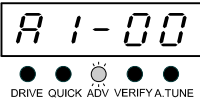
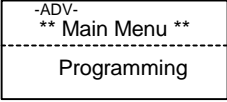
If it is safe to overwrite the parameter set stored in the Digital Operator set o3-02 to 1 and start the READ function again by setting o3-01 to 1.

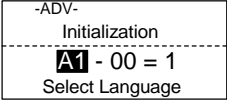
■ Writing Parameter Set Values Stored in the Digital Operator to the Inverter (COPY)

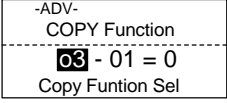
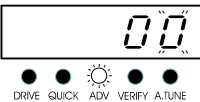
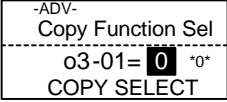
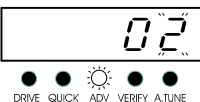
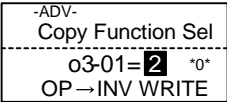
To write parameter set values stored in the Digital Operator to the Inverter, use the following method.

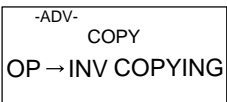
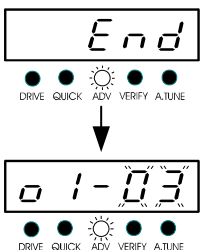
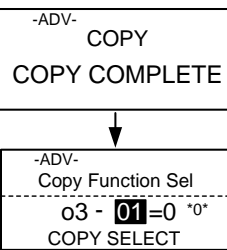
Step No.	Digital Operator Display		Explanation
	LED Digital Operator	LCD/HOA Digital Operator	
1			Press the MENU key until the Advanced Programming Mode is reached.
2			Press the DATA/ENTER key to enter the Function Selection Display in Advanced Programming Mode.
3			Scroll to parameter o3-01 (Copy Function Selection) using the Increment key and Decrement key.
4			Press the DATA/ENTER key to enter the Parameter Setting Display.
5			Change the set value to 2 using the Increment key.
6			Press the DATA/ENTER key. The COPY function will start.
7			If the COPY function is completed "End" respectively "Copy Complete" is displayed on the Digital Operator. Then the display returns to the Monitor Display and parameter o1-03 is automatically reset to 0.

If a fault is displayed press any key to clear the fault display and return to the o3-01 display. Fault displays and their meanings are shown on the following page.

■ Comparing Inverter Parameters and Digital Operator Parameter Set Values (VERIFY)

To compare Inverter parameters and Digital Operator parameter set values, use the following method.

Step No.	Digital Operator Display		Explanation
	LED Digital Operator	LCD/HOA Digital Operator	
1			Press the MENU key until the Advanced Programming Mode is reached.
2			Press the DATA/ENTER key to enter the Function Selection Display in Advanced Programming Mode.
3			Scroll to Parameter o3-01 (Copy Function Selection) using the Increment key and Decrement key.
4			Press the DATA/ENTER key to enter the Parameter Setting Display.
5			Change the set value to 3 using the Increment key.
6			Press the DATA/ENTER key. The VERIFY function will start.
7			When the VERIFY function is completed "End" respectively "Verify Complete" is displayed on the Digital Operator for approx. 1 second. Then the display returns to the Monitor Display and parameter o1-03 is automatically reset to 0.

If an fault is displayed, press any key to cancel the fault display and return to the o3-01 display. Fault displays and their meanings are shown below. (Refer to [Chapter 7, Digital Operator Copy Function Faults.](#))

■ Application Precautions

When using the copy function, check that the following settings are the same between the Inverter and the Digital Operator.

- Inverter product and type
- Software number
- Inverter capacity and voltage

◆ Prohibiting Writing Parameters from the Digital Operator

If A1-01 is set to 0 only the parameters A1-01 and A1-04 are displayed and can be set, U1-□□, U2-□□ and U3-□□ are displayed.

If A1-01 is set to 1 only the parameters A1-01, A1-04 and A2-□□ are displayed and can be set, U1-□□, U2-□□ and U3-□□ are displayed.

If A1-01 is set to 2 all parameters are displayed and can be set.

When the parameter write enable function is programmed to one of the multi-function digital inputs (H1-□□=1B) all parameters are write protected as long as this digital input is switched OFF. The moment it is switched ON the parameters can be changed.

■ Related Parameters

Parameter Number	Name	Setting Range	Factory Setting	Change during Operation	Access Level
A1-01	Parameter access level	0 to 2	2	Yes	A

Multi-Function Digital Inputs (H1-01 to H1-05)

Set Value	Function
1B	Parameters write enable

◆ Setting a Password

When a password is set in A1-05, and if the set values in A1-04 and A1-05 do not match, the settings of parameters A1-01 to A1-03, or A2-01 to A2-32 can not be modified.

The setting of all parameters except A1-00 can be prohibited by using the password function in combination with setting A1-01 to 0 (Monitor only): As long as A1-04 does not match A1-05 parameter A1-01 can not be changed.

To set a password parameter A1-05 has to be accessed in following way:

Scroll to A1-04, hold the Shift/RESET key pressed and press the MENU key additional. A1-05 will be displayed and the Setting Display can be entered.

■ Related Parameters

Parameter Number	Name	Setting Range	Factory Setting	Change during Operation	Access Level
A1-01	Parameter access level	0 to 2	2	Yes	A
A1-04	Password	0 to 9999	0	No	A
A1-05	Password setting	0 to 9999	0	No	A

◆ Displaying User-set Parameters Only

The A2 parameters (user-set parameters) and A1-01 (parameter access level) can be used to establish a parameter set that contains only the most important parameters.

Set the of the parameters to which A2-01 to A2-32 should refer to and then set A1-01 to 1. In Advanced Programming Mode now only the parameters assigned to A2-01 to A2-32 are displayed and can be changed.

■ Related Parameters

Parameter Number	Name	Setting Range	Factory Setting	Change during Operation	Access Level
A2-01 to A2-32	User-set parameters	b1-01 to o3-02	–	No	A



7

Troubleshooting

This chapter describes the fault displays and countermeasure for Inverter and motor problems.

Protective and Diagnostic Functions.....	7-2
Troubleshooting	7-15

Protective and Diagnostic Functions

This section describes the alarm functions of the Inverter. The alarm functions include fault detection, alarm detection, operation error detection, and autotuning error detection.

◆ Fault Detection

When the Inverter detects a fault, the fault relay operates, and the Inverter output is switched OFF causing the motor to coast to stop. (The stopping method can be selected for some faults.) A fault code is displayed on the Digital Operator.

When a fault has occurred, refer to the following table to identify the fault and to correct the causes.

Use one of the following methods to reset the fault before restarting the Inverter:

- Set a multi-function digital input (H1-01 to H1-05) to 14 (Fault Reset) and switch the input ON.
- Press the Shift/RESET key on the Digital Operator.
- Turn the main circuit power supply OFF and then ON again.
- To reset a fault it is necessary to witch OFF the RUN command.

Table 7.1 Fault Detection





Display	Meaning	Probable Causes	Corrective Actions
 OC Over Current	Overcurrent The Inverter's output current exceeded the overcurrent detection level.	Shorted Inverter output phase-to-phase, shorted motor, locked rotor, load too heavy, accel/decel time too short, contactor on the Inverter output has opened or closed, a special motor or a motor with a rated current larger than the Inverter's output current is used.	<ul style="list-style-type: none"> • Remove the motor and run the Inverter without motor • Check the motor for a phase to phase short. • Check the Inverter for a phase to phase short at the output. • Verify the accel/decel time settings
 GF Ground Fault	Ground Fault The ground fault current at the Inverter output exceeded approximately 50% of the Inverter rated output current and L8-09=1 (Ground fault detection enabled)	One Inverter output was shorted to ground and/or a DCCT is defective.	<ul style="list-style-type: none"> • Remove the motor and run the Inverter without motor. • Check the motor for a phase to ground short. • Check the output current with a clampmeter to verify the DCCT reading.
 PUF DC Bus Fuse Open	DC Bus Fuse Blown The fuse in the main circuit is open. Warning: Never run the Inverter after replacing the DC bus fuse without checking for shorted components	Shorted Inverter output and/or damaged IGBTs	<ul style="list-style-type: none"> • Check the motor and motor cables for short circuits or insulation failures (phase to phase) • Replace the Inverter after correcting the cause.
 OV DC Bus Overvolt	DC Bus Overvoltage The DC bus voltage has exceeded the overvoltage detection level. Refer to page 6-100 for the OV detection level.	<ul style="list-style-type: none"> • The deceleration time is too short and the regenerative energy from the motor is too large. • The power supply voltage is too high. 	<ul style="list-style-type: none"> • Increase the deceleration time settings (C1-02/04/09) or connect a braking option. • Check the power supply voltage and decrease the voltage to meet the Inverter's specification.

Table 7.1 Fault Detection

Display	Meaning	Probable Causes	Corrective Actions
$U \ U \ 1$	DC Bus Undervoltage The DC bus voltage is below the Undervoltage Detection Level (L2-05). The default settings are: 200 V class: 190 VDC 400V class: 380VDC	<ul style="list-style-type: none"> The voltage fluctuations of the power supply are too high. A momentary power loss has occurred. The terminal screws of the input power supply are loose. 	<ul style="list-style-type: none"> Check the input voltage. Check the wiring of the input terminals. Increase the accel time settings C1-01/03. In case of Main Circuit MC Operation Failure replace the Inverter.
UV1 DC Bus Undervolt	Main Circuit MC Operation Failure The MC stopped responding during Inverter operation. (Applicable Inverter Capacities 200 V class: 37 to 110 kW 400 V class: 75 to 300 kW)	<ul style="list-style-type: none"> An open-phase error occurred at the input terminals. The acceleration time is set too short. A fault occurred in the inrush current prevention circuit. 	
$U \ U \ 2$	Control Power Supply Undervoltage Undervoltage of the control circuit while the Inverter was running.	An external load at the control terminals was pulling down the Inverter's power supplies or there was an internal short in the power/gate drive board.	<ul style="list-style-type: none"> Remove all connections to the control terminals and cycle the power to the Inverter. Replace the Inverter.
UV2 CTL PS Undervolt			
$U \ U \ 3$	Inrush Current Prevention Circuit Fault An overheating of the charging resistor for the DC bus capacitors occurred.	The contactor of the inrush current prevention circuit is defective.	<ul style="list-style-type: none"> Cycle the power to the Inverter. Replace the Inverter
UV3 MC Answerback	The MC of the charging circuit did not respond 10 sec. after the MC ON signal has been output. (Applicable Inverter Capacities: 200 V class: 37 to 110 kW 400 V class: 75 to 300 kW)		
$P \ F$	Main Circuit Voltage Fault An unusual big ripple on the DC bus voltage has been detected.	<ul style="list-style-type: none"> An open-phase occurred in the input power supply. A momentary power loss occurred. The wiring terminals for the input power supply are loose. The voltage fluctuations in the input power supply are too high. The voltage balance between the phases is bad. 	<ul style="list-style-type: none"> Tighten the input terminal screws Replace the Inverter
PF Input Phase Loss	Only detected when L8-05=1, the detection level is set by L8-06 (refer to page 6-48)		
$O \ H$	Heatsink Overheat The temperature of the Inverter's cooling fin exceeded the setting in L8-02 while L8-03 = 0 to 2.	<ul style="list-style-type: none"> The ambient temperature is too high. There is a heat source nearby. The Inverter's cooling fan(s) stopped. The Inverter's internal cooling fan has stopped and L8-32=1 	<ul style="list-style-type: none"> Check for dirt build-up on the fans or heatsink. Install a cooling unit. Remove the heat source. Replace the cooling fan(s)
OH Heatsink Overtemp	Inverter's Cooling Fan Stopped		
$O \ H \ 1$	Heatsink Overheat The temperature of the Inverter's heatsink exceeded 105 °C	<ul style="list-style-type: none"> The ambient temperature is too high. There is a heat source nearby. The Inverter's cooling fan(s) stopped. The Inverter's internal cooling fan has stopped.and L8-32=1 	<ul style="list-style-type: none"> Check for dirt build-up on the fans or heatsink. Install a cooling unit. Remove the heat source. Replace the cooling fan(s)
OH1 Heatsnk MAX Temp	Inverter's Cooling Fan Stopped		

Table 7.1 Fault Detection

Display	Meaning	Probable Causes	Corrective Actions
OH3 Motor Overheat 1	Motor Overheat Detected when the level at A2, programmed for motor temperature (thermistor input, H3-09=E), exceeds 1.17 V for the time L1-05 and L1-03 = 0 to 2.	Overheating of the motor has been measured by the motor thermistor.	<ul style="list-style-type: none"> • Check the cycle time and the size of the load. • Check the accel/decel times (C1-□□). • Check the V/f pattern (E1-□□)
OH4 Motor Overheat 4	Motor Overheat Detected when the level at A2, programmed for motor temperature (thermistor input, H3-09=e), exceeds 2.34 V for the time L1-05.	Overheating of the motor has been measured by the motor thermistor.	<ul style="list-style-type: none"> • Check the cycle time and the size of the load. • Check the accel/decel times (C1-□□). • Check the V/f pattern (E1-□□)
OL1 Motor Overload	Motor Overload Detected when L1-01 = 1 to 3 and the Inverter's output current exceeded the motor overload curve. Refer to page 6-33 for parameter settings.	<ul style="list-style-type: none"> • The load is too large. The acceleration time, deceleration time and cycle time are too short. • The voltage settings of the V/f pattern is incorrect for the application • The setting of the Motor Rated Current (E2-01) is incorrect. 	<ul style="list-style-type: none"> • Check the cycle time, the size of the load and the accel/decel time settings (C1-□□). • Check the setting of the V/f pattern (E1-□□). • Check the setting of Motor Rated Current (E2-01)
OL2 Inv Overload	Inverter Overload The internally calculated I ² t value (based on the Inverter rated current) has exceeded its detection level.	<ul style="list-style-type: none"> • The load is too large. The acceleration time, deceleration time and cycle time are too short. • The voltage settings of the V/f pattern is incorrect for the application • The capacity of the Inverter is too small 	<ul style="list-style-type: none"> • Check the cycle time, the size of the load and the accel/decel time settings (C1-□□). • Check the setting of the V/f pattern (E1-□□). • Check the setting of Motor Rated Current (E2-01) • Check if the Inverter rated current matches the motor rated current.
OL3 Overtorque Det 1	Overload Detection Inverter's output current exceeded L6-02 for longer then the time set in L6-03 and L6-01=3 or 4.	Motor was overloaded	<ul style="list-style-type: none"> • Ensure the values in L6-02 and L6-03 are appropriate • Check the application/machine status to eliminate fault.
OL7 HSB OL	High Slip Braking OL The output frequency stayed constant for longer than the time set in n3-04 during High Slip Braking.	The inertia of the load is too large.	<ul style="list-style-type: none"> • Make sure the load is an inertial load. • If possible, reduce the load inertia
LL3 Loss of Load Det	Loss of Load Detection Inverter's output current was below L6-02 for longer then the time set in L6-03 and L6-01= 7 or 8.	Motor lost its load	<ul style="list-style-type: none"> • Make sure that the settings in L6-02 and L6-03 are appropriate. • Check the mechanical system (mechanical connection of the load, e.g. belt).
FBL Feedback Loss	PI Feedback Lost This fault occurs when PI feedback loss detection is programmed to fault (b5-12 = 2) and the PI feedback fell below the PI Feedback Loss Detection Level (b5-13) for the PI Feedback Loss Detection Time (b5-14)	PI feedback source (e.g. transducer, sensor, building automation signal) is not installed correctly or is not working	<ul style="list-style-type: none"> • Check the PI feedback signal source for correct operation. • Check the wiring of the PI feedback signal.

Table 7.1 Fault Detection

Display	Meaning	Probable Causes	Corrective Actions
<i>E F 0</i>	External fault input from Communications Option Card (F6-03=1 to 2)	An external fault condition was present, input from a communication option card.	<ul style="list-style-type: none"> • Check for an external fault condition • Verify the parameters • Verify communication signals
EF0 External Fault			
<i>E F 3</i>	External fault at terminal S3		
EF3 Ext Fault S3			
<i>E F 4</i>	External fault at terminal S4		
EF4 Ext Fault S4			
<i>E F 5</i>	External fault at terminal S5	An "external fault" was input from a multi-function input terminal (S3 to S7).	Remove the cause of the external fault.
EF5 Ext Fault S5			
<i>E F 6</i>	External fault at terminal S6		
EF6 Ext Fault S6			
<i>E F 7</i>	External fault at terminal S7		
EF7 Ext Fault S7			
<i>o P r</i>	Digital Operator Connection Fault	The Digital Operator has been disconnected from the Inverter.	<ul style="list-style-type: none"> • Check the connection to the Digital Operator.
OPR Oper Disconnect	Detected when the Digital Operator is removed and if o2-06 = 1.		
<i>C E</i>	MEMOBUS Communication Fault	Connection is broken and/or the master has stopped the communication.	<ul style="list-style-type: none"> • Check the connections and all user-side software configurations.
CE Memobus Com Err	Detected when control data was not received correctly for 2 seconds and H5-04=0 to 3 and H5-05=1.		
<i>b u s</i>	Option Communication Fault	Connection is broken and/or the master as stopped the communication.	<ul style="list-style-type: none"> • Check the connections and al user-side software configurations.
BUS Option Com Err	After initial communication was established, the connection was lost.		
<i>C P F 0 0</i>	Digital Operator Communication Fault 1	<ul style="list-style-type: none"> • The Digital Operator's cable was not securely connected. • Digital Operator is defective. • Control board is defective 	<ul style="list-style-type: none"> • Disconnect the Digital Operator and then connect it again. • Replace the Inverter. • Cycle the Inverter power supply. • Replace the Inverter.
CPF00 COM-ERR(OP&INV)	Communication with the Digital Operator could not be established within 5 seconds after the power was supplied to the Inverter. CPU External RAM Fault		
<i>C P F 0 1</i>	Digital Operator Communication Fault 2	<ul style="list-style-type: none"> • The Digital Operator's cable was not securely connected. • Digital Operator is defective. • Control board is defective 	<ul style="list-style-type: none"> • Disconnect the Digital Operator and then connect it again. • Replace the Inverter. • Cycle the Inverter power supply. • Replace the Inverter.
CPF01 COM-ERR(OP&INV)	After communication with the Digital Operator was established the communication stopped for 2 seconds or more.		

Table 7.1 Fault Detection

Display	Meaning	Probable Causes	Corrective Actions
<i>CPF02</i>	Baseblock Circuit Fault A baseblock circuit error occurred at power-up.	Gate array hardware failure at power-up.	<ul style="list-style-type: none"> • Try to initialize the Inverter. • Cycle the Inverter power.supply. • Replace the Inverter.
CPF02 BB Circuit Err			
<i>CPF03</i>	EEPROM Fault Checksum is not valid.	Noise or spikes was on the control circuit input terminals or the control board is damaged.	
CPF03 EEPROM Error			
<i>CPF04</i>	CPU Internal A/D Converter Fault	Noise or spikes was on the control circuit input terminals or the control board is damaged.	
CPF04 Internal A/D Err			
<i>CPF05</i>	CPU External A/D Converter Fault	Noise or spikes was on the control circuit input terminals or the control board is damaged.	
CPF05 External A/D Err			
<i>CPF06</i>	Option Card Connection Error	<ul style="list-style-type: none"> • The Option Card is not connected properly. • The Inverter or Option Card is faulty. 	
CPF06 Option Error			
<i>CPF07</i>	ASIC Internal RAM Fault	The control circuit is damaged.	
CPF07 RAM-Err			
<i>CPF08</i>	Watchdog Timer Fault	The control circuit is damaged.	
CPF08 WAT-Err			
<i>CPF09</i>	CPU-ASIC Mutual Diagnosis Fault	The control circuit is damaged.	
CPF09 CPU-Err			
<i>CPF10</i>	ASIC Version Fault	The control circuit is damaged.	
CPF10 ASIC-Err			
<i>CPF20</i>	Communications Option Card A/D Converter Fault	<ul style="list-style-type: none"> • The Option Card is not connected properly. • The Option Card's A/D converter is faulty. 	
CPF20 Option A/D Error			

Table 7.1 Fault Detection

Display	Meaning	Probable Causes	Corrective Actions
<i>CPF21</i> CPF21 Option CPU Down	Self-Diagnosis Fault of Option Board	Noise or spikes was on the control circuit input terminals or the control board is damaged.	<ul style="list-style-type: none"> • Turn off the power and re-install the option board. • Remove all inputs from the option board. • Try to initialize the Inverter. • Cycle the power to the Inverter. • Replace the Option Board. • Replace the Inverter.
<i>CPF22</i> CPF22 Option Type Err	Option Board Code Number Fault	Unrecognizable option board is connected to the control board.	
<i>CPF23</i> CPF23 Option DPRAM Err	Option Board Interconnection Fault	An option board was not correctly connected to the control board or an option board that was not made for the Inverter is attached to the control board.	

◆ Alarm Detection

Alarms are detected as a type of Inverter protection function that do not operate the fault relay output. The system will automatically return to its original status when the cause of the alarm has been removed.

The Digital Operator display and the Alarm LED flashes and the alarm can be output at the multi-function outputs (H2-01 or H2-02). As long as the Inverter remains in Alarm status it can not be started and will not accept parameter changes.

When an alarm occurs, take appropriate countermeasures according to the table below.

Table 7.2 Alarm Content

Display	Meaning	Probable Causes	Corrective Actions
$E F$ (flashing)	Forward/Reverse Run Commands Input Together Both the forward and the reverse run commands are input simultaneously for 500 msec or more. This alarm will decelerate the motor stop	The external forward and reverse command were input simultaneously.	Check external sequence logic, so only one input is received at a time.
EF External Fault (flashing)			
$U U$ (flashing)	DC Bus Undervoltage The DC bus voltage is below the Undervoltage Detection Level (L2-05). The default settings are: 200 V class: 190 VDC 400 V class: 380 VDC The MC of the inrush current prevention circuit opened. The control power supply voltage was below the CUV level.	<ul style="list-style-type: none"> The voltage fluctuations of the power supply are too high. A momentary power loss has occurred. The terminal screws of the input power supply are loose. An open-phase error occurred at the input terminals. The acceleration time is set too short. A fault occurred in the inrush current prevention circuit. An external load at the control terminals was pulling down the Inverter's power supplies or there was an internal short in the power/gate drive board. 	<ul style="list-style-type: none"> Check the input voltage. Check the wiring of the input terminals. In case of Main Circuit MC Operation Failure replace the Inverter. Remove all connections to the control terminals and cycle the power to the Inverter. Replace the Inverter.
UV DC Bus Undervolt (flashing)			
$O U$ (flashing)	DC Bus Overvoltage The DC bus voltage exceeded the overvoltage detection level. Refer to page 6-100 for the OV detection level. OV Alarm is only detected when the drive is in a stopped condition	The power supply voltage is too high.	Check the power supply and decrease the voltage to meet the Inverter's specifications
OV DC Bus Overvolt (flashing)			
$O H$ (flashing)	Heatsink Overheat Alarm The temperature of the Inverter's cooling fin exceeded the setting in L8-02 while L8-03 = 3	<ul style="list-style-type: none"> The ambient temperature is too high. There is a heat source nearby. The Inverter cooling fan(s) has stopped. 	<ul style="list-style-type: none"> Check for dirt build-up on the fans or heatsink. Install a cooling unit. Remove the heat source.
OH Heatsnk Overtmp (flashing)			
$O H 3$ (flashing)	Motor Overheat Alarm Detected when the level at A2, programmed for motor temperature (thermistor input, H3-09=E), exceeds 1.17 V for the time L1-05 and L1-03 = 3	Overheating of the motor has been measured by the motor thermistor.	<ul style="list-style-type: none"> Check for dirt build-up on the fans or heatsink. Install a cooling unit. Remove the heat source.
OH3 Motor Overheat 1 (flashing)			

Table 7.2 Alarm Content

Display	Meaning	Probable Causes	Corrective Actions
OL3 (flashing)	Overload Detection The Inverter's output current exceeded L6-02 for longer than the time set in L6-03 and L6-01 = 1 or 2.	Motor was overloaded	<ul style="list-style-type: none"> • Ensure that the values in L6-02 and L6-03 are appropriate • Check the application/machine status to eliminate the fault.
OL3 Overtorque Det.1 (flashing)			
LL3 (flashing)	Loss of Load Detection Inverter's output current was below L6-02 for longer then the time set in L6-03 and L6-01=5 or 6.	Motor lost its load	<ul style="list-style-type: none"> • Make sure that the settings in L6-02 and L6-03 appropriate • Check the application/machine status to eliminate the alarm.
LL3 Loss of Load Det			
EF0 (flashing)	External Fault Input from Communication Option Card (Alarm only) (F6-03=3)	An external fault condition was present, input from a communication option card while F6-03 is set to Alarm only.	<ul style="list-style-type: none"> • Check for an external fault condition. • Verify the parameter settings. • Verify communication signals.
EF0 Opt External Flt (flashing)			
EF3 (flashing)	External fault at terminal S3 (Alarm only)		
EF3 Ext Fault S3 (flashing)			
EF4 (flashing)	External fault at terminal S4 (Alarm only)		
EF4 Ext Fault S4 (flashing)			
EF5 (flashing)	External fault at terminal S5 (Alarm only)	An external fault was input from a multi-function digital input (H1-01 to H1-05) that is programmed for external fault function that gives an alarm only and continues to run the motor.	Remove the cause of the external fault.
EF5 Ext Fault S5 (flashing)			
EF6 (flashing)	External fault at terminal S6 (Alarm only)		
EF6 Ext Fault S6 (flashing)			
EF7 (flashing)	External fault at terminal S7 (Alarm only)		
EF7 Ext Fault S7 (flashing)			
FbL (flashing)	PI Feedback Lost This alarm occurs when PI feedback loss detection is programmed to alarm (b5-12=1) and the PI feedback fell below the PI Feedback Loss Detection Level (b5-13) for the PI Feedback Loss Detection (b5-14).	PI feedback source (e.g. transducer, sensor, building automation signal) is not installed correctly or is not working.	<ul style="list-style-type: none"> • Check the PI feedback signal source for correct operation. • Check the wiring of the PI feedback signal.
FBL Feedback Loss			

Table 7.2 Alarm Content

Display	Meaning	Probable Causes	Corrective Actions
<i>CE</i> (flashing)	MEMOBUS Communications Alarm Detected when control data was not received correctly for 2 seconds and H5-04=4 and H5-05=1.	Connection is broken and/or the master has stopped the communication.	Check the connections and all user-side software configurations.
CE MEMOBUS Com Err (flashing)			
<i>b u s</i> (flashing)	Option Card Communications Alarm After initial communication was established, the connection was lost.	Connection is broken and/or the master has stopped the communication.	Check the connections and all user-side software configurations.
BUS Option Com Err (flashing)			
<i>CALL</i> (flashing)	Communication on Standby Communication has not yet been established.	Connection was not made properly or user software was not configured to the proper baud rate or configuration (e.g. Parity)	Check the connections and all user-side software configurations.
CALL ComCall			
<i>d n E</i> (flashing)	Drive not Enabled Detected when a multi-function digital input (H1-01 to H1-05) is programmed for 6A or 70. The Inverter does not have the enable command when the RUN command is applied. This alarm decelerates the motor.	<ul style="list-style-type: none"> • Enable command was lost while the Inverter was running. • The RUN command was applied prior to the enable signal. 	<ul style="list-style-type: none"> • Check the wiring and sequence of the external signals. • Apply and maintain the enable command before applying the RUN signal
DNE Drive not Enable (flashing)			
<i>Ext Run active</i> <i>Cannot Reset</i>	Detected when a RESET command is input while the RUN command is still active.	The RUN command has not been removed and a RESET command is input by digital input or by the RESET button on the Digital Operator.	Remove the RUN signal first and reset the fault.
<i>Ext Run active</i> <i>Cannot Reset</i>			
<i>P r H T</i> (flashing)	Motor is preheating.	One of the digital inputs (H1-01 to H1-05) is programmed to 60 or 80 and the input is switched ON.	<ul style="list-style-type: none"> • Check the wiring and sequence of the external signals. • Check the parameter settings.
PRHT Motor Preheating (flashing)			
<i>o v r d</i> (flashing)	Emergency Override is active	On of the digital inputs (H1-01 to H1-05) is programmed to 81 or 82 and the input is switched ON	<ul style="list-style-type: none"> • Check the wiring and sequence of the external signals. • Check the parameter settings.
OVRD Emergency Override (flashing)			
<i>F A n</i> (flashing)	Internal Cooling Fan Alarm The Inverter's internal cooling fan failed while L8-32=0	The Inverter' internal cooling fan failed or is blocked.	<ul style="list-style-type: none"> • Check the internal cooling and clean it in case it is dirty. • Replace the cooling fan or the Inverter.
FAN Cooling FAN Err			

◆ Operator Programming Errors

An Operator Programming Error (OPE) occurs when an inapplicable parameter is set or an individual parameter setting is inappropriate. The Inverter will not operate until the parameter is set correctly; however, no alarm or fault outputs will occur. If an OPE occurs, change the appropriate parameter by checking the cause shown in Table 7.3. When OPE error is displayed, press the ENTER key to display U1-34 (OPE Detected). This monitor will display the parameter that is causing the OPE error.

Table 7.3 Operator Programming Errors

Display	Meaning	Probable Causes	Corrective Action
<i>o P E 0 1</i>	Inverter kVA Setting Error	The control board was replaced and the kVA parameter (o2-04) is set incorrectly	Enter the correct kVA setting (o2-04) by referring to the table "Factory settings that change with the Inverter kVA setting" on page 5-60.
OPE01 kVA Selection			
<i>o P E 0 2</i>	Parameter Setting Out of Range	Parameter setting was outside of the allowed range.	Verify the parameter settings.
OPE02 Limit			
<i>o P E 0 3</i>	Multi-function Input Selection Error	<p>One of the following errors has been made in the multi-function input (H1-01 to H1-05) settings:</p> <ul style="list-style-type: none"> • Duplicate functions were selected. • UP/DOWN command (setting 10 and 11) were not set simultaneously. • The UP/DOWN commands (10 and 11) and Accel/decel ramp hold (A) were set at the same time. • More than one of the Speed Search inputs (61, 62, 64) were set simultaneously. • External Baseblock NO (8) and External Baseblock NC (9) were set at the same time. • The UP/DOWN commands (10 and 11) were selected while PI Control (b5-01) was enabled. • The Emergency Stop Command NO and NC were set at the same time. • Motor Preheat (60) and Motor Preheat 2 (80) were set simultaneously. • Emergency Override FWD (81) and Emergency Override REV (82) are set simultaneously. 	Verify the parameter settings in H1-□□
OPE03 Terminal			
<i>o P E 0 5</i>	<p>RUN/Reference Command Selection Error</p> <p>The Reference Source Selection b1-01 and/or the RUN Source Selection parameter b1-02 are set to 3 (option board) but no option board is installed.</p>	Option board is not installed or is installed incorrectly	<ul style="list-style-type: none"> • Verify that the board is installed. Switch off the power supply and re-install the option board. • Recheck the setting of b1-01 and b1-02.
OPE05 Sequence Select			

Table 7.3 Operator Programming Errors

Display	Meaning	Probable Causes	Corrective Action
<i>oPE09</i>	PI Control Setup Error	The following settings have been made at the same time. <ul style="list-style-type: none"> • b5-01 (PI Control Mode Selection) has been set to a value different from 0. • b5-15 (PI Sleep Function Operation Level) has been set to a value different from 0. • b1-03 (Stopping Method Selection) has been set to 2 or 3. 	Check the settings of parameters b5-01, b5-15 and b1-03
OPE09 PI Selection			
<i>oPE10</i>	V/f Parameter Setting Error	Parameters E1-04, E1-06, E1-07, E1-09 and E1-11 do not satisfy the following conditions: <ul style="list-style-type: none"> • E1-04 (FMAX) \geq E1-11 (FMID2) > E1-06 (FA) > E1-07 (FB) \geq E1-09 (FMIN) 	<ul style="list-style-type: none"> • Check the parameter settings of E1-□□ • A frequency/voltage value might be set higher than the maximum frequency/voltage.
OPE10 V/f Ptrn Setting			
<i>oPE11</i>	Carrier Frequency Parameter Setting Error	One of the following parameter setting errors exists: <ul style="list-style-type: none"> • Carrier frequency Gain C6-05 > 6 and C6-03 (Carrier Frequency Upper Limit) < C6-04 (Carrier Frequency Lower Limit) • Upper/lower limit error in C6-03 and C6-04. 	Check the parameter settings of C6-02 to C6-05.
OPE11 CarrFrq/On-Delay			
<i>Err</i>	EEPROM write error The NV-RAM data do not match the EEPROM data	A verification error occurred when writing EEPROM.	<ul style="list-style-type: none"> • Cycle the Inverter power supply. • Try to initialize the Inverter.
ERR EEPROM R/W Err			

◆ Autotuning Faults

Auto-tuning faults are shown below. When the following faults are detected, the fault is displayed on the digital operator and the motor coasts to stop. No fault or alarm outputs will be operated.

Table 7.4 Autotuning Faults

Display	Meaning	Probable causes	Corrective Actions
<i>Er - 01</i>	Motor data fault	<ul style="list-style-type: none"> There is an error in the data input for autotuning. There is an error in the relationship between the motor power and the motor rated current. 	<ul style="list-style-type: none"> Check the input data. Check the Inverter and motor capacity. Check the motor rated current setting.
Er - 01 Fault			
<i>Er - 02</i>	Alarm	An alarm is detected during autotuning.	<ul style="list-style-type: none"> Check the input data. Check wiring and the machine. Check the load.
Er - 02 Minor Fault			
<i>Er - 03</i>	STOP key input	The STOP key was pressed to cancel autotuning.	-
Er - 03 STOP key			
<i>Er - 04</i>	Line-to-Line Resistance Fault	<ul style="list-style-type: none"> Autotuning was not completed in the specified time. The autotuning result is outside the parameter setting range. 	<ul style="list-style-type: none"> Check the input data. Check motor wiring.
Er - 04 Resistance			
<i>End - 3</i>	Rated current setting alarm. Displayed after autotuning is completed.	The rated current is set too high.	Check the motor rated current value.
End - 3 Rated FLA Alm			

◆ Digital Operator Copy Function Faults

These faults can occur during the digital operator COPY function. When a fault occurs, the fault content is displayed on the operator. A fault does not activate the fault relay output or alarm output.

Table 7.5 Digital Operator Copy Function Faults

Function	Display	Probable causes	Corrective Actions
Read	<i>PrE</i> PRE READ IMPOSSIBLE	o3-01 was set to 1 to read parameters when the Digital Operator was write-protected (o3-02 = 0).	Set o3-02 to 1 to enable writing parameters into the Digital Operator's memory.
	<i>IFE</i> IFE READ DATA ERROR	The data file read from the Inverter was of the wrong size indicating corrupted data.	<ul style="list-style-type: none"> Retry the read command. Check the Digital Operator's cable Replace the Digital Operator
	<i>r d E</i> RDE DATA ERROR	An attempted writing of the Inverter data to the Digital Operator's EEPROM failed.	<ul style="list-style-type: none"> A low Inverter voltage has been detected. Retry the read command Replace the Digital Operator.

Table 7.5 Digital Operator Copy Function Faults

Function	Display	Probable causes	Corrective Actions
Copy	<i>CPE</i>	The Inverter type or software number was different from the stored data in the digital operator	Use stored data of the same product (E7) and software number (U1-14) only.
	CPE ID UNMATCHED		
	<i>VAE</i>	The capacity of the Inverter and the capacity of the stored data in the Digital Operator are different.	Use stored data for the same Inverter capacity only (o2-04).
	VAE INV. KVA UNMATCH		
	<i>CYE</i>	A parameter setting written to the Inverter was different from the setting stored in the Digital Operator.	Retry the COPY function (o3-01 = 2)
	CYE COPY ERROR		
	<i>CSE</i>	Upon completion of the COPY function, the Inverter's data checksum was different than the digital operator's data checksum.	Retry the COPY function (o3-01 = 2)
CSE SUM CHECK ERROR			
Verify	<i>VYE</i>	The set value of the digital operator and the Inverter do not match	Retry the VERIFY function (o3-01 = 3)
	VYE VERIFY ERROR		

Troubleshooting

Due to parameter setting errors, faulty wiring, and so on, the Inverter and motor may not operate as expected when the system is started up. If that occurs, use this section as a reference and perform the appropriate counter measures.

If the contents of the fault are displayed, refer to *Protective and Diagnostic Functions*.

◆ If Parameters Cannot Be Set

■ The display does not change when the Increment and Decrement keys are pressed.

The following causes are possible.

The Inverter is operating (Drive Mode).

There are some parameters that cannot be set during operation. Turn off the RUN command and then make the settings.

Parameter write enable is input.

This occurs when "Parameters write enable" (set value: 1B) is set for a multi-function digital input (H1-01 to H1-05). If the parameter write enable input is OFF, the parameters cannot be changed. Turn it ON and then set the parameters.

Passwords do not match. (Only when a password is set.)

If the parameter A1-04 (Password) and A1-05 (Password Setting) numbers are different, the parameters for the initialize mode cannot be changed. Reset the password.

If you cannot remember the password, display A1-05 (Password Setting) by pressing the Shift/RESET key and the MENU key simultaneously while in the A1-04 display. Then reset the password. (Input the reset password in parameter A1-04.)

■ OPE01 through OPE11 is displayed.

The set value for the parameter is wrong. Refer to *page 7-11, Operator Programming Errors* in this chapter and correct the setting.

■ CPF00 or CPF01 is displayed.

This is a Digital Operator communications error. The connection between the Digital Operator and the Inverter may be faulty. Remove the Digital Operator and then re-connect it.

◆ If the Motor Does Not Operate

■ The motor does not operate when the RUN key on the Digital Operator is pressed.

The following causes are possible.

The operation method setting is wrong.

If parameter b1-02 (RUN command source selection) is set to 1 (control circuit terminal), the motor will not operate when the RUN key is pressed. Either press the LOCAL/REMOTE key to switch to Digital Operator operation or set b1-02 to 0 (Digital Operator).



The LOCAL/REMOTE key can be enabled or disabled by setting o2-01. It is enabled when the Drive Mode is entered and o2-01 is set to 1.

The frequency reference is too low.

If the frequency reference is set below the frequency set in E1-09 (Minimum Output Frequency), the Inverter will not operate.

Raise the frequency reference to at least the minimum output frequency.

■ The motor does not operate when an external operation signal is input.

The following causes are possible.

The Inverter is not in Drive Mode.

If the Inverter is not in drive mode, it will remain in ready status and will not start. Press the MENU key make the DRIVE LED flash, and enter the drive mode by pressing the DATA/ENTER key. The DRIVE LED will light up when Drive Mode is entered.

The RUN command source selection is wrong.

If parameter b1-02 (reference selection) is set to 0 (Digital Operator), the motor will not operate when an external operation signal is input. Set b1-02 to 1 (control circuit terminal) and try again.

The motor will also not operate if the LOCAL/REMOTE key has been pressed to switch to Digital Operator operation. In that case press the LOCAL/REMOTE key again to return to the original setting.



The LOCAL/REMOTE key can be enabled or disabled by setting o2-01. It is enabled when the drive mode is entered and o2-01 is set to 1.

3-wire control is enabled.

The input method for a 3-wire control is different than when operating by forward/stop and reverse/stop (2-wire control). If a 3 wire control is selected, the motor will not operate when a wiring that is suitable for 2-wire control is used. When using a 3-wire control, refer to the wiring example and timing chart on [page 6-10, Performing Operations Using 3-Wire Control](#) and input the proper signals.

When using a 2-wire control, set the multi-function digital input (H1-01 through H1-05, terminals S3 to S7) to a value other than 0.

The frequency reference is too low.

If the frequency reference is set below the frequency set in E1-09 (Minimum Output Frequency), the Inverter will not operate. Raise the frequency reference to at least the minimum output frequency.

■The motor stops during acceleration or when a load is connected.

The load may be too heavy. The Inverter has a stall prevention function and an automatic torque boost function (Torque Compensation), but the motor has a limited responsiveness which might be overloaded if acceleration is too rapid or if the load is too heavy. Lengthen the acceleration time or reduce the load. Also consider increasing the motor and/or Inverter capacity.

■The motor rotates in one direction only.

Reverse run is disabled. If b1-04 (Prohibition of reverse operation) is set to 1 or 3(reverse run prohibited), the Inverter will not accept reverse run commands. To use both forward and reverse operation, set b1-04 to 0 or 2.

◆ If the Direction of the Motor Rotation is Reversed

If the motor rotates in the wrong direction, the motor output wiring may be incorrect. When the Inverter operates in the forward direction, the forward direction of the motor will depend on the manufacturer and the motor type, so be sure to check the motor specification

The direction of the motor rotation can be reversed by switching two wires among U, V, and W. If using an encoder, the polarity will also have to be switched. Also parameter b1-04 can be used to change the rotational direction.

◆ If the Motor Does Not Put Out Torque or If Acceleration is Slow**■The stall prevention level during acceleration is too low.**

If the value set for L3-02 (Stall Prevention Level during Acceleration) is too low, the acceleration time will be very long. Check to be sure that the set value is suitable.

■The stall prevention level during run is too low.

If the value set for L3-06 (Stall Prevention Level during Run) is too low, the speed may drop already at low output torque. Check to be sure that the set value is suitable.

◆ If the Motor Operates at Higher Speed than the Frequency Reference**■The analog frequency reference bias or gain setting is wrong.**

The frequency reference bias or gain set in parameter H3-03 or H3-02 influence the frequency reference. Check to be sure that these set values are suitable.

■PI control is enabled.

If the PI control is enabled (b5-01 = 1 or 2), the Inverter output frequency will change to regulate the process variable to the desired set point. The PID can command a speed up to Maximum Output Frequency (E1-04) even though the reference is much lower.

■ A signal is being input to the multifunction analog input terminal A2.

When “0” (frequency bias) is set for parameter H3-09 (Analog Input A2 Function Selection) a frequency corresponding to the terminal A2 input voltage (current) is added to the frequency reference. Check to be sure that the set value and analog input value are suitable.

◆ If Motor Deceleration is Slow

■ The deceleration time is long even when a braking option is connected.

The following causes are possible.

Stall prevention during deceleration enabled is set.

When a braking option is connected, set parameter L3-04 (Stall Prevention Selection during Deceleration) to 0 (disabled). When this parameter is set to 1 (enabled), the braking option will not work properly.

The deceleration time setting is too long.

Check the deceleration time setting (parameters C1-02 and C1-04).

Motor torque is insufficient.

If the parameters are correct and there is no overvoltage fault, maybe then the motor's power limit is reached. Consider increasing the motor capacity.

◆ If the Motor Overheats

■ The load is too heavy.

If the motor load is too heavy and the motor is used continuously with a torque that exceeds the motor's rated torque, the motor will overheat. Reduce the load amount by lowering the load. Also consider increasing the motor capacity.

■ The ambient temperature is too high.

The motor rating is determined within a particular ambient operating temperature range. The motor will burn out if it is run continuously at the rated torque in an environment in which the maximum ambient operating temperature is exceeded. Lower the motor's ambient temperature to be within its acceptable range.

◆ If peripheral devices like PLCs or other are influenced by the starting or running inverter

If electrical noise is generated by Inverter perform the following countermeasures:

- Change the Inverter's Carrier Frequency Selection (C6-02) to lower the carrier frequency. This will help to reduce the amount of transistor switching noise.
- Install an Input Noise Filter at the Inverter's power input terminals.
- Install an Output Noise Filter at the Inverter's motor terminals.
- Use shielded cables or a conduit. Metal shields electrical noise.
- Separate main circuit wiring from control circuit wiring.

◆ If the Earth Leakage Breaker Operates when a RUN Command is Input

The Inverter's output is pulse modulated, i.e. the output voltage consists of high frequency pulses (PWM). This high frequency signal causes a certain amount of leakage current which may cause the earth leakage breaker to operate and cut off the power supply. Change to a ground fault interrupter with a high leakage detection level (i.e., a sensitivity current of 200 mA or higher, with an operating time of 0.1 s or more), or one that incorporates high frequencies countermeasures (i.e., one designed for use with Inverters). It will also help to some extent to lower the Inverter's Carrier Frequency Selection (C6-02). In addition, remember that the leakage current increases as the cable is lengthened.

◆ If There is Mechanical Oscillation

■ The machinery is making unusual sounds.

There may be resonance between the mechanical system's natural frequency and the carrier frequency.

This is characterized by the motor running with no noise generation, but the machinery vibrates with a high-pitched whine. To prevent this type of resonance, adjust the carrier frequency with parameters C6-02 to C6-05.

There may be resonance between a mechanical system's natural frequency and the output frequency of the Inverter.

To prevent this resonance frequency use the Jump Frequency Function in parameters d3-□□, or have the driven motor and load balanced to reduce vibration.

■ Oscillation and hunting occur.

The torque compensation parameter settings may be incorrect for the machine. Adjust parameters C4-01 (Torque Compensation Gain) and C4-02 (Torque Compensation Delay Time). Decrease C4-01 carefully in steps of 0.05 and/or increase C4-02.

Furthermore the Hunting Prevention Gain (n1-02) can be increased if the problems occur in light load conditions and the Slip Compensation Delay Time (C3-02) can be decreased.

■ Oscillation and hunting occur with PI control.

If there is oscillation or hunting during PI control, check the oscillation cycle and individually adjust P and I parameters (refer to [page 6-87, Using PI Control](#)).

◆ If the Motor Rotates Even When Inverter Output is Stopped

If the motor coasts at low speed after a deceleration to stop has been executed, it means that the DC injection braking is not decelerating enough. Adjust the DC injection braking as follows:

- Increase the parameter b2-02 (DC Injection Braking Current) setting.
- Increase the parameter b2-04 (DC Injection Braking (initial excitation) Time at Stop) setting.

◆ If OV (Overvoltage) or OC (Overcurrent) is Detected When a Fan is Started, or a Fan Stalls

If a fan is windmilling (already rotating in an airstream) and the Inverter tries to start the motor from zero speed on OV (DC bus overvoltage) or OC (Overcurrent) might occur. This can be prevented by stopping the fan rotation using DC injection braking before starting the fan. Alternatively the speed search function can be used to catch the rotating motor.

◆ If Output Frequency Does Not Rise to Frequency Reference

■ The frequency reference is within the jump frequency range.

When the jump frequency function is used, the output frequency does not change within the jump frequency range. Check to be sure that the Jump Frequency (d3-01 to d3-03) and Jump Frequency Width (d3-04) settings are suitable.

■ The frequency reference upper limit has been reached.

The output frequency upper limit is determined by the following formula:

$$\text{Freq Ref Upper Limit} = \text{Max. Output Frequency (E1-04)} \times \text{Frequency Reference Upper Limit (d2-01)} / 100$$

Check to be sure that the parameter E1-04 and d2-01 settings are suitable.



8

Maintenance and Inspection

This chapter describes basic maintenance and inspection for the Inverter.

Maintenance and Inspection8-2

Maintenance and Inspection

◆ Periodic Inspection

■ Periodic Inspection for Inverters of Protection Class IP00 and NEMA 1/ IP20

Check the following items during periodic maintenance.

- The motor should not vibrate or make unusual noises.
- There should be no abnormal heat generation from the Inverter or motor.
- The ambient temperature should be within the Inverter's specifications.
- The output current value shown in U1-03 should not be higher than the motor or the Inverter rated current for extended period of time.
- The cooling fan in the Inverter should be operating normally.

Before attempting any maintenance checks, make sure that the three-phase power is disconnected. With power removed from the unit, the DC bus capacitors will stay charged for several minutes. The Charge LED in the Inverter will glow red until the DC bus voltage is below 10VDC. To ensure that the DC bus is completely discharged, measure between the positive and negative bus with a DC voltmeter set to the highest scale. Be sure not to touch terminals immediately after the power has been turned off. Doing so can result in electric shock.

Table 8.1 General Inspection Items for Inverters of all Protection Classes

Item	Inspection	Corrective Procedure
External terminals Mounting bolts Connectors	Are all screws and bolts tight?	Tighten loose screws and bolts firmly.
	Are connectors tight?	Reconnect the loose connectors.
Cooling fins	Are the fins dirty or dusty?	Clean off any dirt and dust with an air gun using dry air at a pressure of 4×10^5 to 6×10^5 Pa (4 to 6 bar, 55 to 85 psi).
All PCBs	Is there any conductive dirt or oil mist on the PCBs?	Clean off any dirt and dust with an air gun using dry air at a pressure of 4×10^5 to 6×10^5 Pa (4 to 6 bar, 55 to 85 psi). Replace the boards if they cannot be made clean.
Input Diodes Output Transistors Power Modules	Is there any conductive dirt or oil mist on the modules or components?	Clean off any dirt and dust with an air gun using dry air at a pressure of 4×10^5 to 6×10^5 Pa (4 to 6 bar, 55 to 85 psi).
DC bus capacitors	Are there any irregularities, such as discoloration or odor?	Replace the capacitor or Inverter.

Apply power to the Inverter and conduct the following inspection:

Item	Inspection	Corrective Procedure
Cooling Fan(s)	Is there any abnormal noise or vibration, or has the total operating time exceeded 20,000 hours. Check U1-40 for the elapsed cooling operation time.	Replace Cooling Fan

■ Additional Information for Inverters in Protection Class IP54

After switching off the power supply wait at least for five minutes before beginning the inspection. Before opening the door ensure that the space around the Inverter is dry and clean. Water must not splash into the Inverter box as it may destroy the Inverter and can result in electric shock.

Keep any water or dust outside of the Inverter box during the Inspection

Refer to the following table for additional inspection items for IP54 Inverters.

Table 8.2 Inspection Items for IP54 Inverters

Item	Inspection	Corrective Procedure
External terminals Mounting bolts Connectors	Are all screws and bolts tight?	Tighten loose screws and bolts firmly.
	Are connectors tight?	Reconnect the loose connectors.
Cooling fins	Are the fins dirty or dusty?	Clean off any dirt and dust with an air gun using dry air at a pressure of 4×10^5 to 6×10^5 Pa (4 to 6 bar, 55 to 85 psi).
Cooling Fan	Are the cooling fans dirty or dusty	7.5 to 18.5 kW: External cooling fan is attached on the lower side in the wind tunnel. Check the fan from the bottom and clean off any dirt in the same way as cleaning the cooling fin. 22 to 55 kW: External cooling fan is attached on the upper side in the wind tunnel. Check the fan from the top and clean off any dirt in the same way as cleaning the cooling fin.
All PCBs	Is there any conductive dirt or oil mist on the PCBs?	Clean off any dirt and dust with an air gun using dry air at a pressure of 4×10^5 to 6×10^5 Pa (4 to 6 bar, 55 to 85 psi). Replace the boards if they cannot be made clean.
Input Diodes Output Transistors Power Modules	Is there any conductive dirt or oil mist on the modules or components?	Clean off any dirt and dust with an air gun using dry air at a pressure of 4×10^5 to 6×10^5 Pa (4 to 6 bar, 55 to 85 psi).
DC bus capacitors	Are there any irregularities, such as discoloration or odor?	Replace the capacitor or Inverter.
Cable Glands	Are the cable glands tightened properly?	Tighten the cable glands and locknuts.

Apply power to the Inverter and conduct the following inspection:

Item	Inspection	Corrective Procedure
Cooling Fan(s)	Is there any abnormal noise or vibration, or has the total operating time exceeded 20,000 hours. Check U1-40 for the elapsed cooling operation time.	Replace Cooling Fan

◆ Periodic Maintenance of Parts

In order to keep the Inverter operating normally over a long period of time, and to prevent down time due to an unexpected failure, it is necessary to perform periodic inspections and replace parts according to their service life.

The data indicated in the following table is to be used as a general guideline only. Periodic inspection standards vary depending on the Inverter's installation environment conditions and usage. The Inverter's suggested maintenance periods are noted below.

Part	Standard Replacement Period	Replacement Method
Cooling fan(s)	2 to 3 years (20,000 hours)	Replace with new part.
DC bus capacitor	5 years	Replace with new part. (Determine need by inspection.)
Soft charge contactor	–	Determine need by inspection.
DC bus fuse Control power fuse	10 years	Replace with new part.
PCB capacitors	5 years	Replace with new board. (Determine need by inspection.)

Note: The standard replacement period is based on the following usage conditions:
Ambient temperature: Yearly average of 30°C
Load factor: 80% max.
Operating rate: 12 hours max. per day

◆ Cooling Fan Replacement Outline

■ 200 V and 400 V Class Inverters of 18.5 kW or Less

A cooling fan is attached to the bottom of the Inverter.

If the Inverter is installed using the mounting holes on the back of the Inverter, the cooling fan can be replaced without removing the Inverter from the installation panel.

Removing the Cooling Fan

1. Press in on the right and left sides of the fan cover in the direction of arrows 1 and when pull the fan out in the direction of arrow 2.
2. Pull out the cable connected to the fan from the fan cover and disconnect the cable.
3. Open the fan cover on the left and right sides and remove the fan cover from the fan.

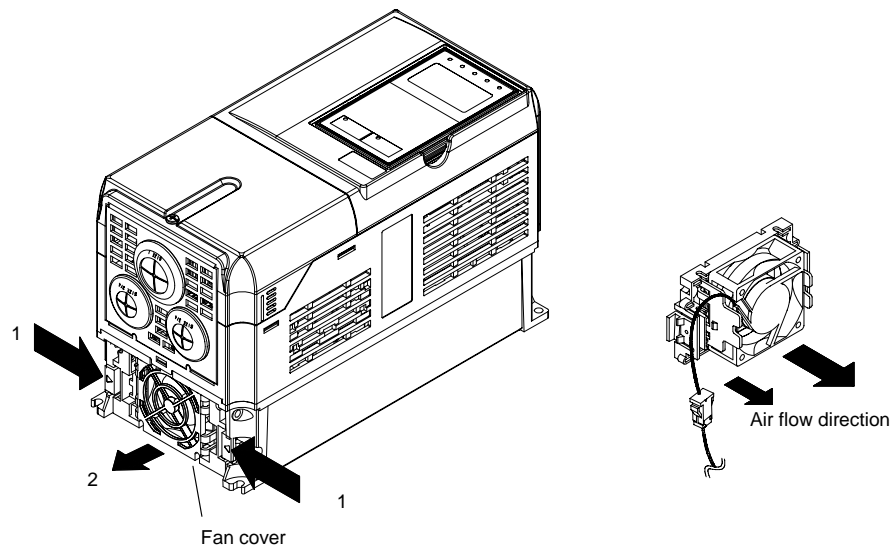

Fig 8.1 Cooling Fan Replacement (Inverters of 18.5 kW or Less)

Mounting the Cooling Fan

1. Attach the fan cover to the cooling fan. Be sure that the air flow direction is correct (see figure above).
2. Connect the cables securely and place the connector and cable into the fan cover.
3. Mount the fan cover on the Inverter. Be sure that the tabs on the sides of the fan cover click into place on the Inverter heatsink.

■ 200 V and 400 V Class Inverters of 22 kW or More

A cooling fan is attached to the top panel inside the Inverter.

The cooling fan can be replaced without removing the Inverter from the installation panel.

Removing the Cooling Fan

1. Remove the terminal cover, Inverter cover, Digital Operator, and front cover from the Inverter.
2. Remove the controller bracket to which the cards are mounted. Remove all cables connected to the controller.
3. Remove the cooling fan power cable connector (CN26 and CN27) from the gate driver positioned at the back of the controller.
4. Remove the fan cover screws and pull out the fan cover from the Inverter.
5. Remove the cooling fan from the fan cover.

Mounting the Cooling Fan

After attaching a new cooling fan, use the above described procedure in reverse order to attach all of the components.

When attaching the cooling fan to the mounting bracket, be sure that the air flow direction faces the top of the Inverter.

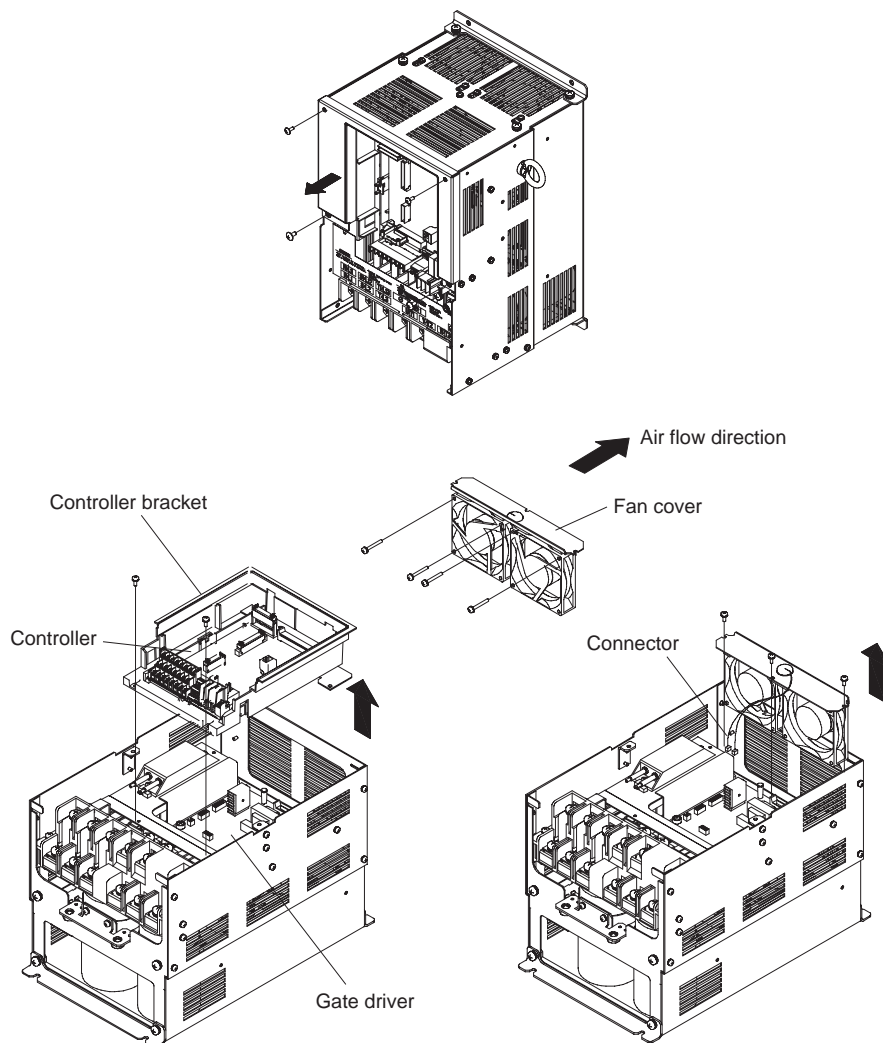

Fig 8.2 Cooling Fan Replacement (Inverters of 22 kW or More)

◆ Removing and Mounting the Control Circuit Terminal Card

■ Removing the Control Circuit Terminal Card

1. Remove the Digital Operator and front cover.
2. Remove the connecting line connectors connected to FE and NC on the control circuit terminal card.
3. Loosen the mounting screws (1) on the left and right sides of the control terminals until they are free. (It is not necessary to remove these screws completely. They are self-rising.)
4. Pull the terminal card out downwards (in direction 2).

■ Mounting the Control Circuit Terminal Card

Use the removal procedure in reverse order to mount the terminal card.

Confirm that the terminal circuit card and the controller card properly meet at connector CN5 before pressing into its plan.

The connector pins may be bent if the card is forced into place!

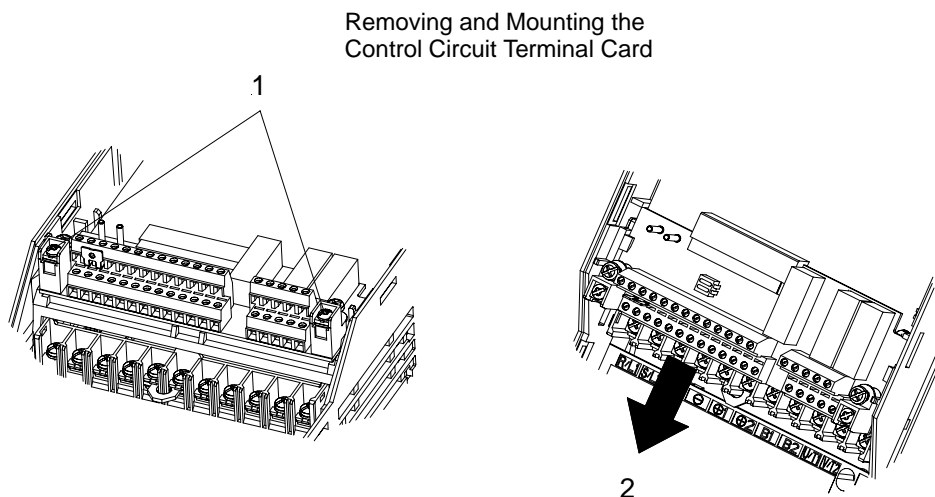

Fig 8.3 Removing the Control Circuit Terminal Card



NOTE

Always confirm that the charge indicator does not light anymore before removing or mounting the control circuit terminal card.





9

Specifications

This chapter describes the basic specifications of the Inverter and specifications for options and peripheral devices.

Standard Inverter Specifications	9-2
--	---------------------

Standard Inverter Specifications

The standard Inverter specifications are listed by capacity in the following tables.

◆ Specifications by Model

Specifications are given by model in the following tables.

■ 200V Class

Model Number CIMR-E7Z □		20P4	20P7	21P5	22P2	23P7	25P5	27P5	2011	2015	2018	2022	2030	2037	2045	2055	2075	2090	2110	
Max. applicable motor output (kW) ^{*1}		0.55	0.75	1.5	2.2	3.7	5.5	7.5	11	15	18.5	22	30	37	45	55	75	90	110	
Output Ratings	Rated output capacity (kVA)	1.2	1.6	2.7	3.7	5.7	8.8	12	17	22	27	32	44	55	69	82	110	130	160	
	Rated output current (A)	3.2	4.1	7.0	9.6	15	23	31	45	58	71	85	115	145	180	215	283	346	415	
	Max. output voltage (V)	3-phase; 200, 220, 230, or 240 VAC (Proportional to input voltage.)																		
	Max. output frequency (Hz)	200.0																		
Power Supply Characteristics	Rated voltage (V) Rated frequency (Hz)	3-phase, 200/208/220/230/240 VAC, 50/60 Hz																		
	Rated input current (A)	3.8	4.9	8.4	11.5	18	24	37	52	68	84	94	120	160	198	237	317	381	457	
	Allowable voltage fluctuation	+ 10%, - 15%																		
	Allowable frequency fluctuation	±5%																		
Control Characteristics	Measures for power supply harmonics	DC reactor	Optional									Built in								
		12-pulse rectification	Not possible									Possible ^{*2}								

*1. The maximum applicable motor output is given for a standard 4-pole Yaskawa motor. When selecting the actual motor and Inverter, be sure that the Inverter's rated current is applicable for the motor's rated current.

*2. A transformer with dual star-delta secondary is required on the power supply for 12-pulse rectification.

■ 400 V Class Inverters in Protection Class IP00 and NEMA 1 / IP20

Model Number CIMR-E7Z □		40P4	40P7	41P5	42P2	43P7	44P0	45P5	47P5	4011	4015	4018
Max. applicable motor output (kW)*1		0.55	0.75	1.5	2.2	3.7	4.0	5.5	7.5	11	15	18.5
Output Ratings	Rated output capacity (kVA)	1.4	1.6	2.8	4.0	5.8	6.6	9.5	13	18	24	30
	Rated output current (A)	1.8	2.1	3.7	5.3	7.6	8.7	12.5	17	24	31	39
	Max. output voltage (V)	3-phase; 380, 400, 415, 440, 460, or 480 VAC (Proportional to input voltage.)										
	Max. output frequency (Hz)	200.0										
Power Supply Characteristics	Rated voltage (V) Rated frequency (Hz)	3-phase, 380, 400, 415, 440, 460 or 480 VAC, 50/60 Hz										
	Rated input current (A)	2.2	2.5	4.4	6.4	9.0	10.4	15	20	29	37	47
	Allowable voltage fluctuation	+ 10%, - 15%										
	Allowable frequency fluctuation	±5%										
Control Characteristics	Measures for power supply harmonics	DC reactor	Optional									
		12-phase rectification	Not possible									

Model Number CIMR-E7Z □		4022	4030	4037	4045	4055	4075	4090	4110	4132	4160	4185	4220	4300
Max. applicable motor output (kW)*1		22	30	37	45	55	75	90	110	132	160	185	220	300
Output Ratings	Rated output capacity (kVA)	34	46	57	69	85	110	140	160	200	230	280	390	510
	Rated output current (A)	45	60	75	91	112	150	180	216	260	304	370	506	675
	Max. output voltage (V)	3-phase, 380, 400, 415, 440, 460, or 480 VAC (Proportional to input voltage.)												
	Max. output frequency (Hz)	200.0												
Power Supply Characteristics	Max. voltage (V) Rated frequency (Hz)	3-phase, 380, 400, 415, 440, 460, or 480 VAC, 50/60 Hz												
	Rated input current (A)	50	66	83	100	120	165	198	238	286	334	407	537	743
	Allowable voltage fluctuation	+ 10%, - 15%												
	Allowable frequency fluctuation	±5%												
Control Characteristics	Measures for power supply harmonics	DC reactor	Built in											
		12-phase rectification	Possible*2											

*1. The maximum applicable motor output is given for a standard 4-pole Yaskawa standard motor. When selecting the actual motor and Inverter, be sure that the Inverter's rated current is higher than the motor's rated current.

*2. A transformer with dual star-delta secondary is required on the power supply for 12-pulse-rectification.

■400 V Class Inverters in Protection Class IP54

Model Number CIMR-E7Z □		47P5	4011	4015	4018	4022	4030	4037	4045	4055
Max. applicable motor output (kW) ^{*1}		7.5	11	15	18.5	22	30	37	45	55
Output Ratings	Rated output capacity (kVA)	13	18	24	30	34	46	57	69	85
	Rated output current (A)	17	24	31	39	45	60	75	91	112
	Max. output voltage (V)	3-phase; 380, 400, 415, 440, 460, or 480 VAC (Proportional to input voltage.)								
	Max. output frequency (Hz)	200.0								
Power Supply Characteristics	Rated voltage (V) Rated frequency (Hz)	3-phase, 380, 400, 415, 440, 460 or 480 VAC, 50/60 Hz								
	Rated input current (A)	20	29	37	47	50	66	83	100	120
	Allowable voltage fluctuation	+ 10%, - 15%								
	Allowable frequency fluctuation	±5%								
Control Characteristics	Measures for power supply harmonics	DC reactor	Optional			Built in				
		12-phase rectification	Not possible							

*1. The maximum applicable motor output is given for a standard 4-pole Yaskawa standard motor. When selecting the actual motor and Inverter, be sure that the Inverter's rated current is higher than the motor's rated current.

◆ Common Specifications

The following specifications apply to both 200 V and 400 V Class Inverters.

Model Number CIMR-E7Z □		Specification
Control Characteristics	Control method	Sine wave PWM V/f control
	Speed control range	1:40
	Speed control accuracy	±3 (25°C ± 10°C)
	Frequency control range	0.0 to 200.0 Hz
	Frequency accuracy (temperature characteristics)	Digital references: ± 0.01% (-10°C to +40°C)
		Analog references: ±0.1% (25°C ± 10°C)
	Frequency setting resolution	Digital references: 0.01 Hz
		Analog references: 0.025/50 Hz (11 bits plus sign)
	Output frequency resolution	0.01 Hz
	Frequency setting signal	0 to +10V, 4 to 20 mA
	Acceleration/Deceleration time	0.01 to 6000.0 s (2 selectable combinations of independent acceleration and deceleration settings)
Braking torque	Approximately 20%	
Main control functions	Restarting for momentary power loss, speed searches, overload detection, 5-speed control (maximum), acceleration/deceleration time changes, S-curve acceleration, 3-wire control, autotuning, cooling fan ON/OFF control, torque compensation, jump frequencies, upper and lower limits for frequency references, DC braking for starting and stopping, motor preheat function, High Slip braking, PI control (with sleep/snooze function, scaling with units), energy-saving control, MEMOBUS communications (RS-485/422, 19.2 kbps maximum), emergency override, fault reset, and copy function.	
Protective functions	Motor protection	Protection by electronic thermal overload relay.
	Instantaneous overcurrent protection	Stops at approx. 200% of rated output current.
	Fuse blown protection	Stops for fuse blown.
	Overload protection *1	120% of rated output current for 1 minute
	Overvoltage protection	200 Class Inverter: Stops when main-circuit DC voltage is above 410 V. 400 Class Inverter: Stops when main-circuit DC voltage is above 820 V.
	Undervoltage protection	200 Class Inverter: Stops when main-circuit DC voltage is below 190 V. 400 Class Inverter: Stops when main-circuit DC voltage is below 380 V.
	Momentary power loss ride through	By selecting the momentary power loss method, operation can be continued if power is restored within 2 s.
	Cooling fin overheating	Protection by thermistor.
	Stall prevention	Stall prevention during acceleration, deceleration, or running.
	Grounding protection	Protection by electronic circuits.
Charge indicator	Lights up when the main circuit DC voltage is approx. 50 V or more.	
Protective structure		Enclosed wall-mounted type (NEMA 1): 18.5 kW or less (same for 200 V and 400 V class Inverters) Open chassis type (IP00): 22 kW or more (same for 200 V and 400 V class Inverters)
Environment	Ambient operating temperature	-10°C to 40°C (NEMA 1 / IP20 and IP54) -10°C to 45°C (IP00)
	Ambient operating humidity	95% max. (with no condensation)
	Storage temperature	- 20°C to + 60°C (short-term temperature during transportation)
	Application site	Indoor (no corrosive gas, dust, etc.)
	Altitude	1000 m max.
	Vibration	10 to 20 Hz, 9.8 m/s ² max.; 20 to 50 Hz, 2 m/s ² max

*1. Increase the Inverter capacity if loads exceeding these current values are expected.



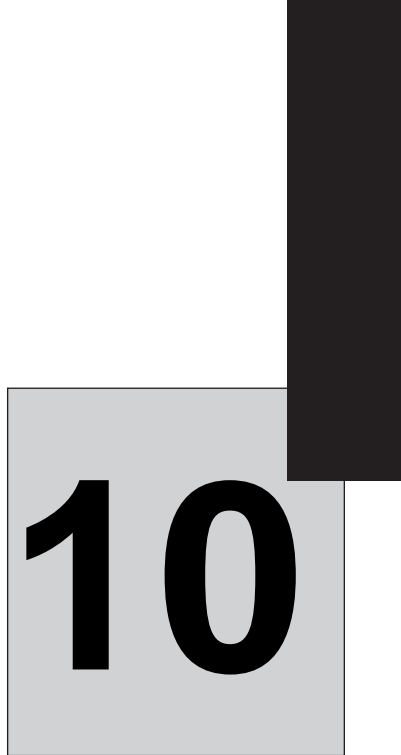

10

Appendix

This chapter provides precautions for the Inverter, motor, and peripheral devices and also provides lists of parameters.

Inverter Application Precautions	10-2
Motor Application Precautions	10-4
User Parameters	10-6

Inverter Application Precautions

◆ Selection

Observe the following precautions in selecting an Inverter.

■ Installing Reactors

A large peak current will flow in the power input circuit when the Inverter is connected to a large-capacity power transformer (600 kVA or higher) or when switching a compensating capacitor. Excessive peak current can destroy the rectifier section. To prevent this, install a DC or AC reactor (optional) to improve the power supply power factor.

DC reactors are built into Inverters of 22 and more.

If a thyristor converter, such as a DC drive, is connected in the same power supply system, connect a DC or AC reactor regardless of the power supply conditions shown in the following diagram.

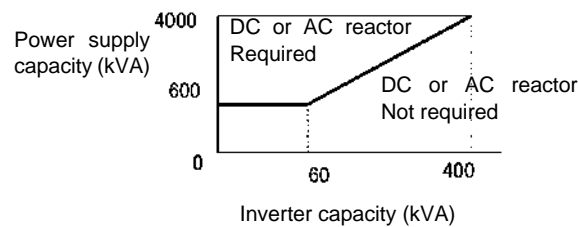

■ Inverter Capacity

When connecting special motors or multiple motors in parallel to an Inverter, select the Inverter capacity so that the rated output current of the Inverter is minimum 1.1 times the sum of all the motor rated currents.

■ Initial Torque

The startup and acceleration characteristics of the motor are restricted by the overload current ratings of the Inverter that is driving the motor. The torque characteristic generally is different from those when starting a motor on the power supply directly. If a large initial torque is required, select an Inverter one size bigger or increase the capacity of both, the motor and the Inverter.

◆ Installation

Observe the following precautions when installing an Inverter.

■ Installation in Enclosures

Install the Inverter in a clean location where it is not subjected to oil mist, dust, and other contaminants, or install the Inverter in a completely enclosed panel. Provide cooling measures and sufficient panel space so that the temperature surrounding the Inverter does not exceed the allowable temperature. Do not install the Inverter on wood or other combustible materials.

■ Installation Direction

Mount the Inverter vertically to a wall or other vertical surface.

◆ Settings

Observe the following precautions when making settings for an Inverter.

■ Upper Limits

The maximum output frequency can be set up to 120Hz. Setting the output frequency too high can damage the machine. So pay attention to the mechanical system and observe required limits for the output frequency.

■ DC Injection Braking and Motor Preheat

If the DC injection braking current, the braking time or the motor preheat current or are set too high the motor can overheat what can damage the motor.

■ Acceleration/Deceleration Times

The motor's acceleration and deceleration times are determined by the torque generated by the motor, the load torque, and the load's inertial moment ($GD^2/4$). If the stall prevention functions are activated during acceleration or deceleration, it might be necessary to increase the acceleration or deceleration time.

To reduce the acceleration or deceleration times, increase the capacity of the motor and Inverter.

◆ Handling

Observe the following precautions when wiring or performing maintenance for an Inverter.

■ Wiring Check

The Inverter will be internally damaged if the power supply voltage is applied to output terminal U, V, or W. Check wiring for any mistakes before supplying power. Check all wiring and control sequences carefully.

■ Magnetic Contactor Installation

If a magnetic contactor is installed in the power supply line, do not exceed one start every 30 minutes. Switching more often can damage the inrush current prevention circuit.

■ Maintenance and Inspections

After turning OFF the main circuit power supply it can take several minutes before the DC bus is discharged completely. The CHARGE LED, indicating if the DC bus is charged, glows above a voltage of 10VDC.

Motor Application Precautions

◆ Using the Inverter for an Existing Standard Motor

Observe the following precautions when using an Inverter for an existing standard motor.

■ Low Speed Ranges

If a standard cooled motor is used at low speed the cooling effects are diminished. If the motor is used in constant torque applications in low speed area the motor may overheat. If full torque is required at low speed continuously an externally cooled motor must be used.

■ Installation Withstand Voltage

If the Inverter is used with an input voltage of 440 V or higher and long motor cables, voltage spikes at the motor terminals may occur which can damage the motor windings. Ensure that the motor insulation class is sufficient.

■ Acoustic Noise

The acoustic noise generated in the motor depends on the carrier frequency. The higher the setting, the less is the generated acoustic noise.

◆ Using the Inverter for Special Motors

Observe the following precautions when using a special motor.

■ Pole-changing Motor

The rated input current of pole-changing motors differs from that of standard motors. Select an appropriate Inverter according to the maximum current of the motor.

■ Submersible Motor

The rated input current of submersible motors is higher than that of standard motors. Therefore, always select an Inverter by checking its rated output current. When the distance between the motor and Inverter is long, use a motor cable with high cross section to prevent voltage drop and thereby motor torque reduction.

■ Explosion-proof Motor

When an explosion-proof motor is used, it must be subjected to an explosion-proof test in conjunction with the Inverter. This is also applicable when an existing explosion-proof motor is to be operated with the Inverter. Since the Inverter itself is, however, not explosion-proof always install it in a safe place.

■ Gearmotor

The speed range for continuous operation differs according to the lubrication method and motor manufacturer. In particular, continuous operation of an oil-lubricated motor in the low speed range may result in damaging. If the motor is to be operated at a speed higher than 50 Hz, consult the manufacturer.

■ Single-phase Motor

Do not use an Inverter for a single-phase motor. These motors are often equipped with phase-shift capacitors. Any capacitor directly connected to the inverter output may damage the Inverter.

◆ Power Transmission Mechanism (Speed Reducers, Belts and Chains)

If an oil-lubricated gearbox or speed reducer is used in the power transmission mechanism, oil lubrication will be affected when the motor operates only in the low speed range. The power transmission mechanism will be more noisy and might experience problems with service life and durability if the motor is operated at low speeds continuously.

User Parameters

A complete parameter table with the factory default settings can be found in the following table. The factory settings are given for 200V class Inverter with 0.4 kW.

No.	Name	Factory Setting	Setting
A1-00	Language selection for digital operator display (LED/HOA Digital Operator)	0	
A1-01	Parameter access level	2	
A1-03	Initialize	0	
A1-04	Password	0	
A1-05	Password setting	0	
A2-01 to A2-32	User-set parameters	–	
b1-01	Reference source selection	1	
b1-02	RUN command source selection	1	
b1-03	Stopping method selection	0	
b1-04	Prohibition of reverse operation	0	
b1-07	Operation selection after switching to remote mode	0	
b1-08	Run command selection in programming modes	0	
b1-11	RUN delay	0 sec.	
b1-12	HAND frequency reference source selection	0	
b1-13	HAND/AUTO switching during run selection	0	
b1-14	Emergency override speed	0.00 Hz	
b1-15	Emergency override reference selection	0	
b2-01	DC injection braking starting frequency (Zero speed level)	0.5 Hz	
b2-02	DC injection braking current	50%	
b2-03	DC injection braking time at start	0.00 sec.	
b2-04	DC injection braking time at stop	0.50 sec.	
b2-09	Motor preheat current	0%	
b2-10	Motor preheat current 2	5%	
b3-01	Speed search selection	2	
b3-02	Speed search operating current	120%	
b3-03	Speed search deceleration time	2.0 sec.	
b3-05	Speed search wait time	0.2 sec.	
b3-14	Bi-directional speed search selection	1	
b4-01	Timer function ON-delay time	0.0 sec.	
b4-02	Timer function OFF-delay time	0.0 sec.	
b5-01	PI control mode selection	0	
b5-02	Proportional (P) gain	1.00	
b5-03	Integral (I) time	1.0 sec.	
b5-04	Integral (I) limit	100.0%	
b5-06	PI limit	100.0%	
b5-07	PI offset	0.0%	
b5-08	PI delay time constant	0.00 sec.	
b5-09	PI output characteristics selection	0	

No.	Name	Factory Setting	Setting
b5-10	PI output gain	1.0	
b5-11	PI reverse output selection	0	
b5-12	Selection of PI feedback loss detection	0	
b5-13	PI feedback loss detection level	0%	
b5-14	PI feedback loss detection time	1.0 sec.	
b5-15	Sleep function operation level	0.0 Hz	
b5-16	Sleep operation delay time	0.0 sec.	
b5-17	Acceleration/deceleration time for PI reference	0.0 sec.	
b5-18	PI setpoint selection	0	
b5-19	PI setpoint	0.0%	
b5-20	PI setpoint scaling	1	
b5-21	Sleep function selection	1	
b5-22	Snooze level	0%	
b5-23	Snooze delay time	0 sec	
b5-24	Wake-up level	0%	
b5-25	Setpoint boost	0%	
b5-26	Maximum boost time	0 sec	
b5-27	Snooze feedback	60%	
b5-28	PI feedback square root operation	0	
b5-29	PI feedback square root gain	1.00	
b5-30	PI output monitor square root	0	
b5-31	PI unit selection	0 *1	
b8-01	Energy-saving mode selection	0	
b8-04	Energy-saving coefficient	288.20 *2	
b8-05	Power detection filter time constant	20 msec.	
b8-06	Search operation voltage limiter	0%	
C1-01	Acceleration time 1	10.0 sec.	
C1-02	Deceleration time 1	10.0 sec.	
C1-03	Acceleration time 2	10.0 sec.	
C1-04	Deceleration time 2	10.0 sec.	
C1-09	Emergency stop time	10.0 sec.	
C1-11	Accel/decel time switching frequency	0.0 Hz	
C2-01	S-curve characteristic time at acceleration start	0.20 sec.	
C2-02	S-curve characteristic time at acceleration end	0.20 sec.	
C4-01	Torque compensation gain	1.00	
C4-02	Torque compensation time constant	200 msec.	
C6-01	Normal duty selection	1	
C6-02	Carrier frequency selection	6 *3	
C6-03	Carrier Frequency Upper Limit	15 kHz *2	
C6-04	Carrier Frequency Lower Limit	15 kHz *2	
C6-05	Carrier Freq. Proportional Gain	00	

No.	Name	Factory Setting	Setting
d1-01	Frequency reference 1	0.00 Hz	
d1-02	Frequency reference 2	0.00 Hz	
d1-03	Frequency reference 3	0.00 Hz	
d1-04	Frequency reference 4	0.00 Hz	
d1-17	Jog frequency reference	6.00 Hz	
d2-01	Frequency reference upper limit	100.0%	
d2-02	Frequency reference lower limit	0.0%	
d2-03	Master speed reference lower limit	0.0%	
d3-01	Jump frequency 1	0.0 Hz	
d3-02	Jump frequency 2	0.0 Hz	
d3-03	Jump frequency 3	0.0 Hz	
d3-04	Jump frequency width	1.0 Hz	
d4-01	Frequency reference hold function selection	0	
d4-02	Trim control level	10%	
E1-01	Input voltage setting	200 V ^{*4}	
E1-03	V/f pattern selection	F	
E1-04	Max. output frequency	50.0 Hz	
E1-05	Max. output voltage	200.0 V ^{*4}	
E1-06	Base frequency	50.0 Hz	
E1-07	Mid output frequency	2.5 Hz	
E1-08	Mid. output frequency voltage	15.0 V ^{*4}	
E1-09	Min. output frequency	1.2 Hz	
E1-10	Min. output frequency voltage	9.0 V ^{*4}	
E1-11	Mid. output frequency 2	0.0 Hz	
E1-12	Mid. output frequency voltage 2	0.0 V	
E1-13	Base voltage	0.0 V	
E2-01	Motor rated current	1.90 A ^{*2}	
E2-03	Motor no-load current	1.20 A ^{*2}	
E2-05	Motor line-to-line resistance	9.842Ω ^{*2}	
F6-01	Operation selection after communications error	1	
F6-02	Option card external fault detection selection	0	
F6-03	Option card external fault stopping method	1	
F6-05	Current scaling via communication option card	0	
H1-01	Terminal S3 function selection	24	
H1-02	Terminal S4 function selection	14	
H1-03	Terminal S5 function selection	3 (0) ^{*5}	
H1-04	Terminal S6 function selection	4 (3) ^{*5}	
H1-05	Terminal S7 function selection	6 (4) ^{*5}	
H2-01	Terminal M1-M2 function selection	0	
H2-02	Terminal M3-M4 function selection	1	

No.	Name	Factory Setting	Setting
H3-02	Terminal A1 gain	100.0%	
H3-03	Terminal A1 bias	0.0%	
H3-08	Analog input A2 signal level selectoin	2	
H3-09	Analog input A2 function selection	2*6	
H3-10	Terminal A2 gain	100.0%	
H3-11	Terminal A2 bias	0.0%	
H3-12	Analog input filter time constant	0.30 sec.	
H3-13	Terminal A1/A2 switching	0	
H4-01	Terminal FM monitor selection	2	
H4-02	Terminal FM gain	100%	
H4-03	Terminal FM bias	0.0%	
H4-04	Terminal AM monitor selection	8	
H4-05	Terminal AM gain	50%	
H4-06	Terminal AM bias	0.0%	
H4-07	Terminal FM signal level selection	0	
H4-08	Terminal AM signal level selection	0	
H5-01	Station address	1F	
H5-02	Communications speed selection	3	
H5-03	Communications parity selection	0	
H5-04	Stopping method after communications error	3	
H5-05	Communications error detection selection	1	
H5-06	Send wait time	5 msec.	
H5-07	RTS control ON/OFF	1	
H5-08	Communications Selection	0	
H5-09	CE detection time	2.0 sec.	
L1-01	Motor protection selection	1	
L1-02	Motor protection time constant	1.0 min	
L1-03	Alarm operation selection during motor overheating	3	
L1-04	Motor overheating operation selection	1	
L1-05	Motor temperature input filter time constant	0.20 sec.	
L2-01	Momentary power loss detection	0	
L2-02	Momentary power loss ride through time	0.1 sec. *2	
L2-03	Min. baseblock time	0.1sec. *2	
L2-04	Voltage recovery time	0.3 sec *2	
L2-05	Undervoltage detection level	190 V*4	
L3-01	Stall prevention selection during acceleration	1	
L3-02	Stall prevention level during acceleration	120%	
L3-04	Stall prevention selection during deceleration	1	
L3-05	Stall prevention selection during running	1	
L3-06	Stall prevention level during running	120%	
L4-01	Speed agreement detection level	0.0 Hz	

No.	Name	Factory Setting	Setting
L4-02	Speed agreement detection width	2.0 Hz	
L4-05	Operation when frequency reference is missing	1	
L4-06	Frequency reference value at frequency reference loss	80%	
L5-01	Number of auto restart attempts	0	
L5-02	Auto restart operation selection	0	
L5-03	Fault Retry Time	10.0 sec.	
L6-01	Load detection selection	6	
L6-02	Load detection level	15%	
L6-03	Load detection time	10.0 sec.	
L8-02	Overheat pre-alarm level	95 °C ^{*2}	
L8-03	Operation selection after overheat pre-alarm	4	
L8-06	Input phase loss detection level	5.0 % ^{*2}	
L8-09	Ground fault protection selection	1	
L8-10	Cooling fan control selection	0	
L8-11	Cooling fan control delay time	300 sec.	
L8-12	Ambient temperature	45 °C	
L8-15	OL2 characteristics selection at low speeds	1	
L8-18	Soft CLA selection	1	
L8-19	Frequency reference during OH pre-alarm	20.0%	
L8-32	OH1 detection selection for fan failure	1	
n1-01	Hunting prevention function selection	1	
n1-02	Hunting prevention gain	1.00	
n3-01	High slip braking deceleration frequency width	5%	
n3-02	High slip braking current limit	150%	
n3-03	High slip braking stop dwell time	1.0 sec.	
n3-04	High slip braking OL7 time	40 sec.	
o1-01	Monitor selection	6	
o1-02	Monitor selection after power up	1	
o1-03	Digital operator display scaling	0	
o1-05	LCD Focus	3	
o1-06	Monitor mode Selection	0	
o1-07	2nd monitor selection	2	
o1-08	3rd monitor selection	3	
o1-09	Frequency reference display unit selection	0	
o2-01	LOCAL/REMOTE key enable/disable	1	
o2-02	STOP key during control circuit terminal operation	1	
o2-03	User parameter initial value	0	
o2-04	kVA selection	0 ^{*2}	
o2-05	Frequency reference setting method selection	0	
o2-06	Operation selection when digital operator is disconnected	0	
o2-07	Cumulative operation time setting	0 hrs.	
o2-08	Cumulative operation time selection	1	
o2-09	Initialize mode	2	

No.	Name	Factory Setting	Setting
o2-10	Fan operation time setting	0 hrs.	
o2-12	Fault trace initialize	0	
o2-14	kWh monitor initialize	0	
o2-15	HAND key function selection	1	
o2-17	Standard / IP54 Selection	*7	
o3-01	Copy function selection	0	
o3-02	Read permission selection	0	
T1-02	Motor output power	0.40 kW*2	
T1-04	Motor rated current	1.90 A*2	

*1. Parameter function is only valid if a Digital Operator with LCD clear text display is used (LCD or HOA Digital Operator)

*2. The factory setting depends on the Inverter capacity.

*3. The factory setting depends on the Inverter capacity and the protection class.

*4. Values for 200 V class Inverters are shown. For a 400 V class Inverter the values have to be doubled.

*5. The values in parentheses indicate initial values when initialized in 3-wire-sequence.

*6. Setting switched to "B" when PI controller is enabled

*7. The setting depends on the protection class of the Inverter.

