

Miniature Limit Switch D4CC

Many Models Including Roller Lever Switches are Only 16-mm Thick with Connector

- New center roller lever models that enable ganged mounting of up to 6 Switches.
- Cable connectors for easy Switch replacement.
- Triple-seal construction for plungers to provide IEC IP67, UL, and CSA (type 3, 4, 13) degree of protection.
- Operation indicators available for easy monitoring (standard indicator is lit when Switch is not operating).



Model Number Structure

■ Model Number Legend

D4CC- 0

1 2

1. Rated Load

(These codes are different from suffix codes of the D4C)

- 1: 1 A at 125 VAC
- 2: 1 A at 125 VAC (with LED indicator)
- 3: 1 A at 30 VDC
- 4: 1 A at 30 VDC (with LED indicator)

2. Actuator













- 01: Pin plunger
- 02: Roller plunger
- 03: Crossroller plunger
- 10: Bevel plunger
- 24: Roller lever
- 31: Sealed pin plunger
- 32: Sealed roller plunger
- 33: Sealed crossroller plunger
- 41: Panel mount pin plunger
- 42: Panel mount roller plunger
- 43: Panel mount crossroller plunger
- 50: Plastic rod
- 60: Center roller lever

Note: With standard models, the operation indicator turns OFF when the switch operates. If models with operation indicators that turn ON when the switch operates are required, add "-B" to the end of the model number.

Ordering Information

■ List of Models

Limit Switches

Actuator	1 A at 125 VAC		1 A at 30 VDC	
	Without indicator	With indicator	Without indicator	With indicator
Pin plunger 	D4CC-1001	D4CC-2001	D4CC-3001	D4CC-4001
Roller plunger 	D4CC-1002	D4CC-2002	D4CC-3002	D4CC-4002
Crossroller plunger 	D4CC-1003	D4CC-2003	D4CC-3003	D4CC-4003
Bevel plunger 	D4CC-1010	D4CC-2010	D4CC-3010	D4CC-4010
High-sensitivity roller lever 	D4CC-1024	D4CC-2024	D4CC-3024	D4CC-4024
Sealed pin plunger 	D4CC-1031	D4CC-2031	D4CC-3031	D4CC-4031
Sealed roller plunger 	D4CC-1032	D4CC-2032	D4CC-3032	D4CC-4032
Sealed crossroller plunger 	D4CC-1033	---	D4CC-3033	D4CC-4033
Panel mount pin plunger 	D4CC-1041	D4CC-2041	D4CC-3041	D4CC-4041
Panel mount roller plunger 	D4CC-1042	D4CC-2042	D4CC-3042	D4CC-4042
Panel mount crossroller plunger 	D4CC-1043	---	D4CC-3043	D4CC-4043
Plastic rod 	D4CC-1050	D4CC-2050	D4CC-3050	D4CC-4050
Center roller lever 	D4CC-1060	D4CC-2060	D4CC-3060	D4CC-4060

Note: 1. The meaning of suffix codes in the D4CC model numbers is different from that in the D4C model numbers.
2. Refer to the following table for cable plugs.

Accessories (Order Separately)

Plugs

Type	Appearance	No. of conductors	Cable length	Model
VAC	Straight 	4	1 m	XS2F-A421-C90-A
			2 m	XS2F-A421-D90-A
			5 m	XS2F-A421-G90-A
			10 m	XS2F-A421-J90-A
VDC			1 m	XS2F-D421-C80-A
			2 m	XS2F-D421-D80-A
			5 m	XS2F-D421-G80-A
			10 m	XS2F-D421-J80-A

Note: Please contact your local OMRON sales office for details.

Special Mounting Plate

It is possible to replace an WL Limit Switch with a D4CC Limit Switch mounted on this plate without changing the position of the dog or cam.

The following is the conversion table:

WL	D4C	Plate model
Top plunger: WLD	Plunger: D4CC-□001	D4C-P001
Top roller plunger: WLD2	Roller plunger: D4CC-□002	D4C-P002
Roller lever: WLG2	Roller lever: D4CC-□024	D4C-P020

Example

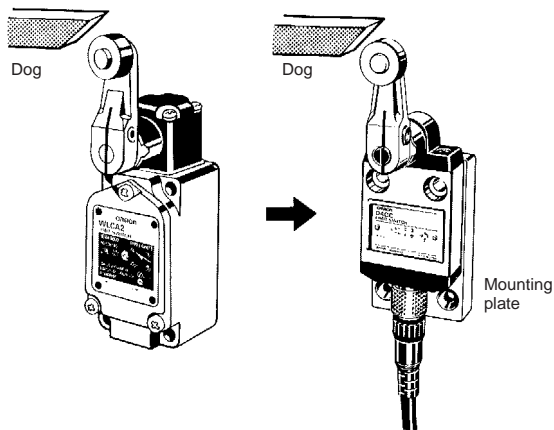

Remarks

There is no difference in mounting pitch between the Mounting Plate and the WL. The mounting depth of the D4CC with the Mounting Plate attached is, however, shorter than that of the panel-mounted WL.

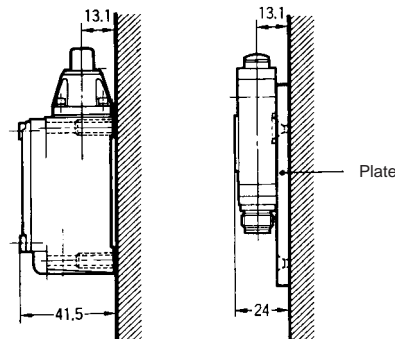

Specifications

Approved Standards

Agency	Standard	File No.
UL	UL508	E76675
CSA	CSA C22.2 No. 14	LR45746

Approved Standard Ratings

UL-CSA D4CC-1, D4CC-2 D150

Rated voltage	Carry current	Current		Volt-amperes	
		Make	Break	Make	Break
120 VAC	1.0 A	3.6 A	0.6 A	432 VA	72 VA

Ratings

Rated voltage	Non-inductive load				Inductive load			
	Resistive load		Lamp load		Inductive load		Motor load	
	NC	NO	NC	NO	NC	NO	NC	NO
125 VAC	1 A	1 A	1 A	0.7 A	1 A	1 A	1 A	1 A
30 VDC	1 A	1 A	1 A	1 A	1 A	1 A	1 A	1 A

- Note:**
- The above current ratings are for steady-state current.
 - Inductive loads have a power factor of 0.4 min. (AC) and a time constant of 7 ms max. (DC).
 - Lamp loads have an inrush current of 10 times the steady-state current.
 - Motor loads have an inrush current of 6 times the steady-state current.

D4CC-3, D4CC-4, 1 A at 30 VDC

Inrush current	NC	5 A max.
	NO	2.5 A max.

■ Characteristics

Degree of protection	IP67
Durability (see note 2)	Mechanical: 10,000,000 operations min. Electrical: 200,000 operations min. (1 A at 125 VAC, resistive load)
Operating speed	Plunger: 0.1 mm to 0.5 m/s Roller lever: 1 mm to 1 m/s
Operating frequency	Mechanical: 120 operations/min Electrical: 30 operations/min
Rated frequency	50/60 Hz
Insulation resistance	100 MΩ min. (at 500 VDC)
Contact resistance (initial)	100 mΩ max.
Dielectric strength	1,000 VAC, 50/60 Hz for 1 min between terminals of same polarity 1,500 VAC, 50/60 Hz for 1 min between current-carrying metal parts and ground, and between each terminal and non-current-carrying metal part
Vibration resistance	Malfunction: 10 to 55 Hz, 1.5-mm double amplitude (see note 3)
Shock resistance	Destruction: 1,000 m/s ² min. Malfunction: 500 m/s ² min.
Ambient temperature	Operating: -10°C to 70°C (with no icing)
Ambient humidity	Operating: 95% max.
Weight	Approx. 120 g (in the case of D4CC-1002)

Note: 1. The above figures are initial values.

- The values are calculated at an operating temperature of 5°C to 35°C, and an operating humidity of 40% to 70%. Contact your OMRON sales representative for more detailed information on other operating environments.
- Excluding plastic rod models.

Leakage Current (for Switches with Indicators)

The leakage current and resistance of Switches with indicators are as follows:

Item	D4CC-2□□□	D4CC-4□□□
Voltage	125 VAC	30 VDC
Leakage current	1.0 mA	1.0 mA
Resistive value	150 kΩ	30 kΩ

■ Operating Characteristics

Model	D4CC-□001	D4CC-□002	D4CC-□003	D4CC-□010	D4CC-□024
OF max.	11.77 N	11.77 N	11.77 N	11.77 N	5.69 N
RF min.	4.41 N	4.41 N	4.41 N	4.41 N	1.47 N
PT max.	1.8 mm	1.8 mm	1.8 mm	1.8 mm	10±3°
OT min.	3 mm	3 mm	3 mm	3 mm	50°
MD max.	0.2 mm	0.2 mm	0.2 mm	0.2 mm	3°
OP	15.7±1 mm	28.5±1 mm	28.5±1 mm	28.5±1 mm	---

Model	D4CC-□031	D4CC-□032	D4CC-□033	D4CC-□041	D4CC-□042	D4CC-□043
OF max.	17.65 N	17.65 N	17.65 N	11.77 N	11.77 N	11.77 N
RF min.	4.41 N	4.41 N	4.41 N	4.41 N	4.41 N	4.41 N
PT max.	1.8 mm	1.8 mm	1.8 mm	1.8 mm	1.8 mm	1.8 mm
OT min.	3 mm	3 mm	3 mm	3 mm	3 mm	3 mm
MD max.	0.2 mm	0.2 mm	0.2 mm	0.2 mm	0.2 mm	0.2 mm
OP	24.9±1 mm	34.3±1 mm	34.3±1 mm	31.2±1 mm	36.8±1 mm	36.8±1 mm
TT (reference value)	(5) mm	(5) mm	(5) mm	(5) mm	(5) mm	(5) mm

Model	D4CC-□050	D4CC-□060
OF max.	1.47 N	6.67 N
RF min.	---	1.47 N
PT max.	15°	10±3°
OT min.	---	50°
MD max.	---	3°

■ Contact Form

AC Switches (D4CC-10□□, 20□□)

Without Indicator

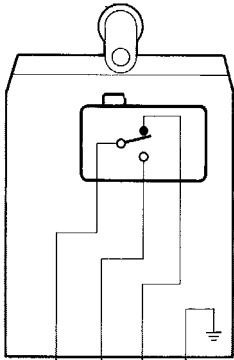

Pin No. (1) (4) (2) (3)
COM NO NC E

With Indicator

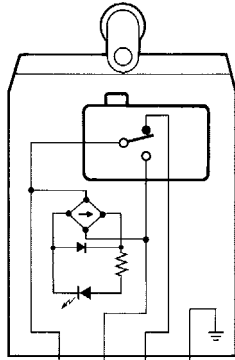

Pin No. (1) (4) (2) (3)
COM NO NC E

With LED Indicator
(lights when operated)

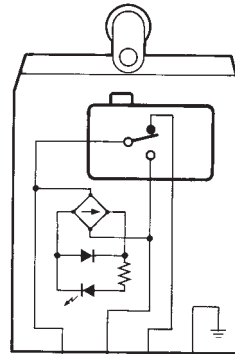

Pin No. (1) (4) (2) (3)
COM NO NC E

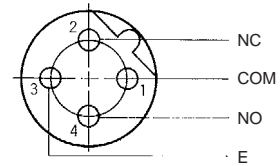

Note: The indicators of these models are lit when the Switches are not actuated. When the Switches are actuated, the indicator are off.

Note 1. "Lights when operated" means that when the actuator is turned or pushed and the Limit Switch contact leaves the NC side, the indicator lights.

2. "Lights when not in operation" means that when the actuator is in the free position, the indicator is lit, and when the actuator is turned or pushed and the contact comes into contact with the NO side, the indicator turns OFF.

DC Switches (D4CC-30□□, 40□□)

Without Indicator

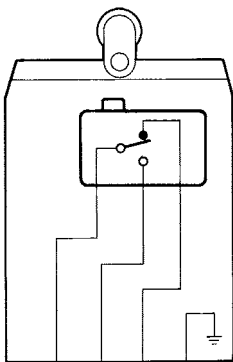

Pin No. (1) (4) (2) (3)
COM NO NC E

With Indicator

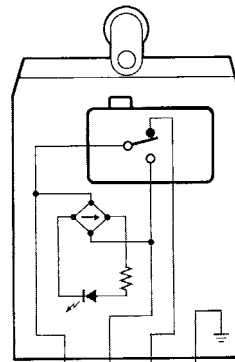

Pin No. (1) (4) (2) (3)
COM NO NC E

With LED Indicator
(lights when operated)

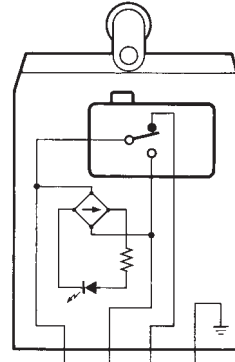

Pin No. (1) (4) (2) (3)
COM NO NC E

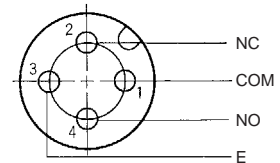

Note: The indicators of these models are lit when the Switches are not actuated. When the Switches are actuated, the indicator are off.

Note 1. "Lights when operated" means that when the actuator is turned or pushed and the Limit Switch contact leaves the NC side, the indicator lights.

2. "Lights when not in operation" means that when the actuator is in the free position, the indicator is lit, and when the actuator is turned or pushed and the contact comes into contact with the NO side, the indicator turns OFF.

Plugs

AC Type

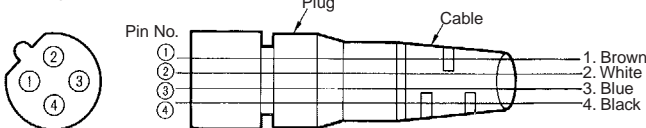

DC Type

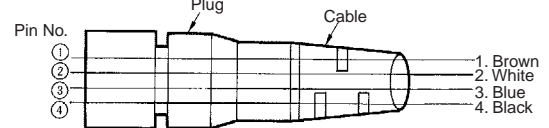

Nomenclature

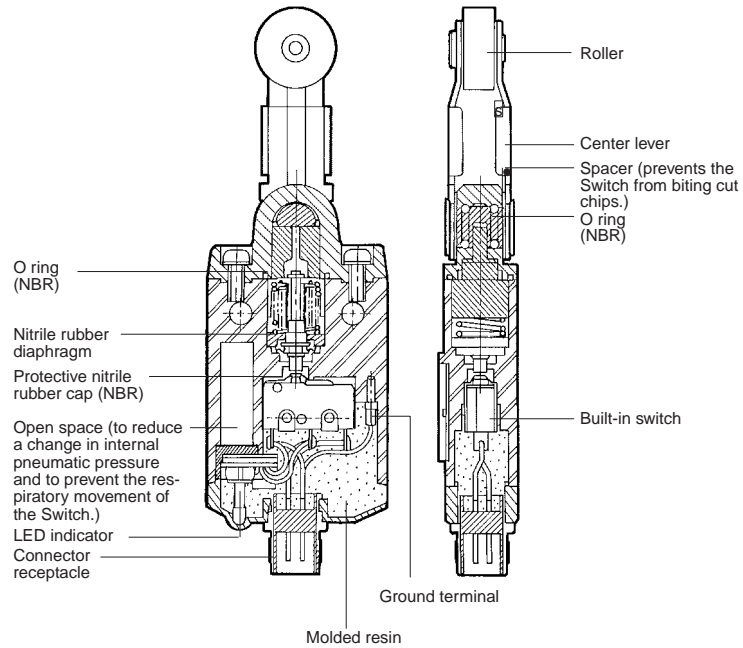

Dimensions

- Note:** 1. All units are in millimeters unless otherwise indicated.
 2. The □ in each model number is replaced with the code expressing the rated load of the model. Refer to *Ordering Information*.
 3. Unless otherwise specified, a tolerance of ± 0.4 mm applies to all dimensions.

Limit Switches

Pin Plunger
D4CC-□001

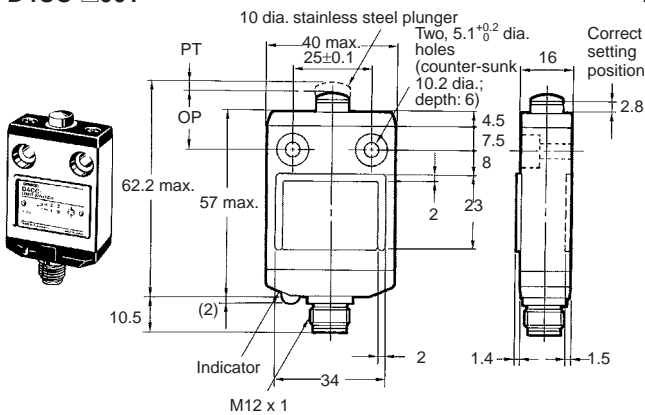

Roller Plunger
D4CC-□002

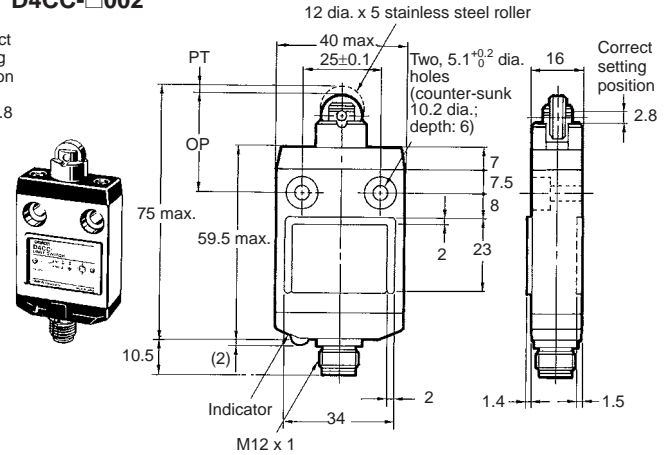

Crossroller Plunger
D4CC-□003

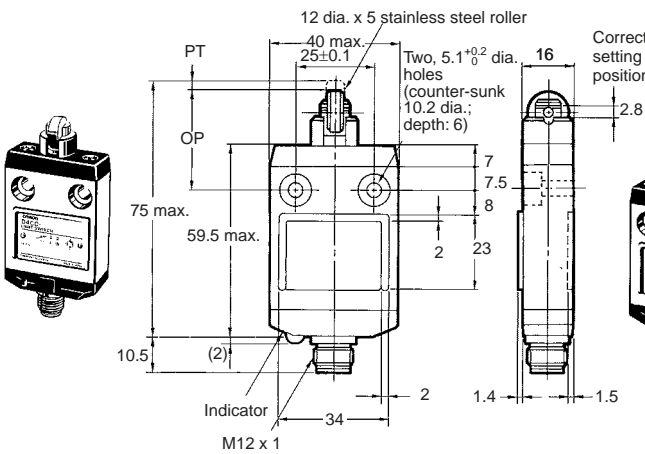

Bevel Plunger
D4CC-□010

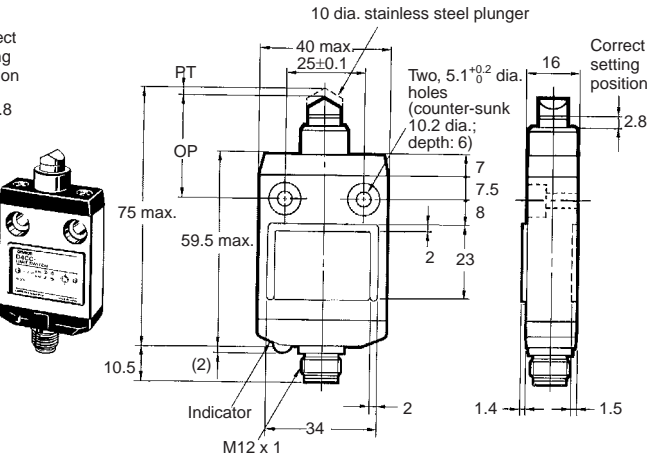

Roller Lever
D4CC-□024

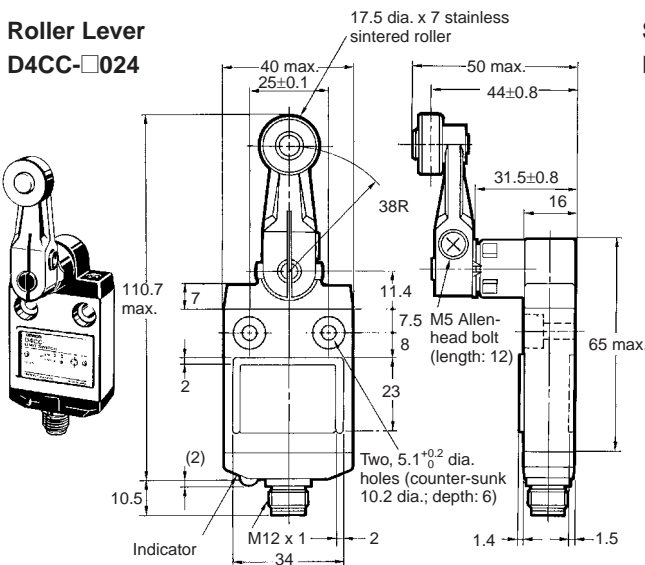

Sealed Pin Plunger
D4CC-□031

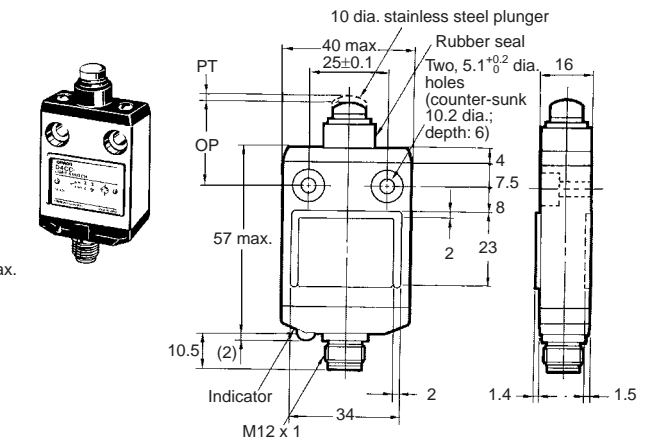

Sealed Roller Plunger
D4CC-□032

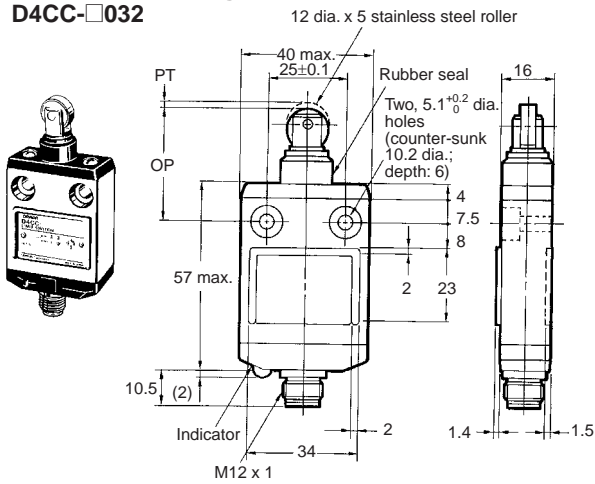

Sealed Crossroller Plunger
D4CC-□033

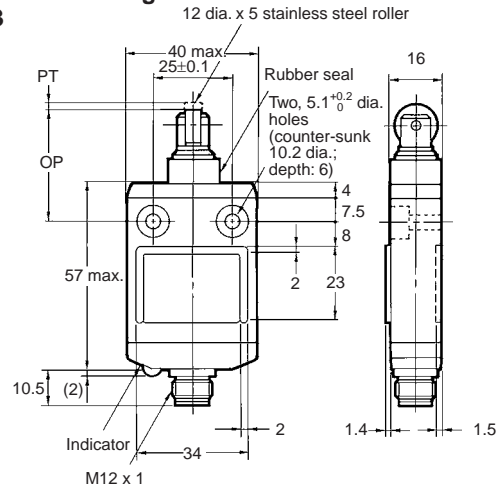

Panel Mount Pin Plunger
D4CC-□041

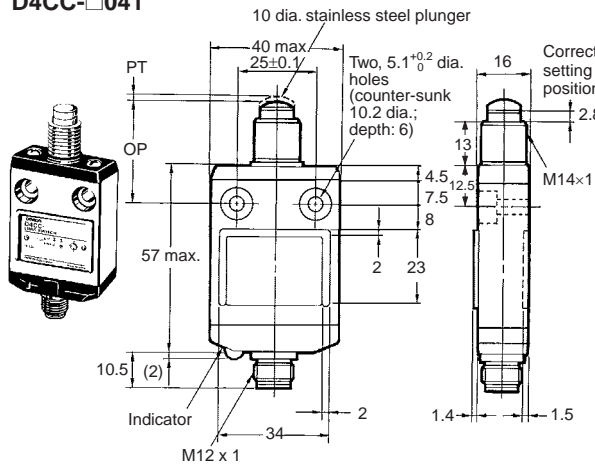

Panel Mount Roller Plunger
D4CC-□042

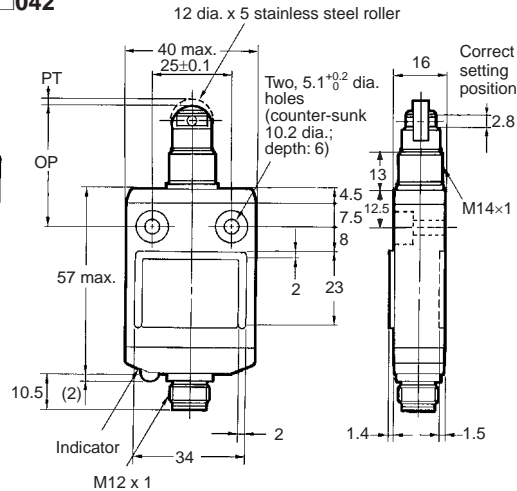

Panel Mount Crossroller Plunger
D4CC-□043

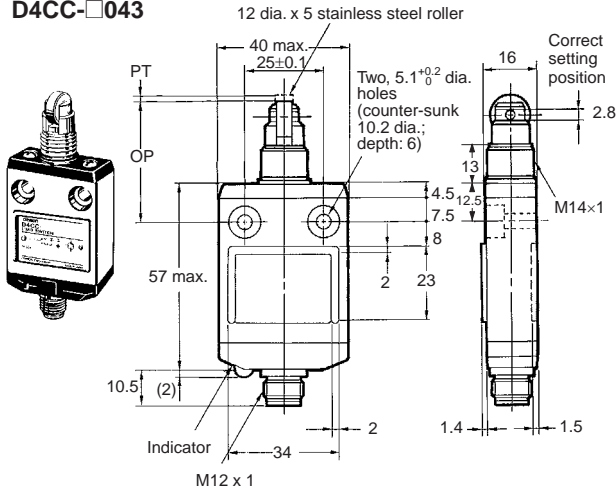

Plastic Rod
D4CC-□□50

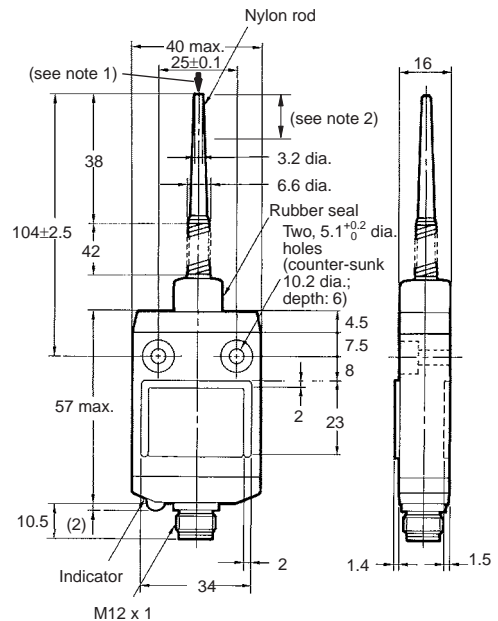

Note: 1. Operation is possible in any direction except parallel to the axis ↓.
2. The ideal range for operation is between the tip of the rod and 1/3 of the length of the actuator.

Center Roller Lever
D4CC-□□60

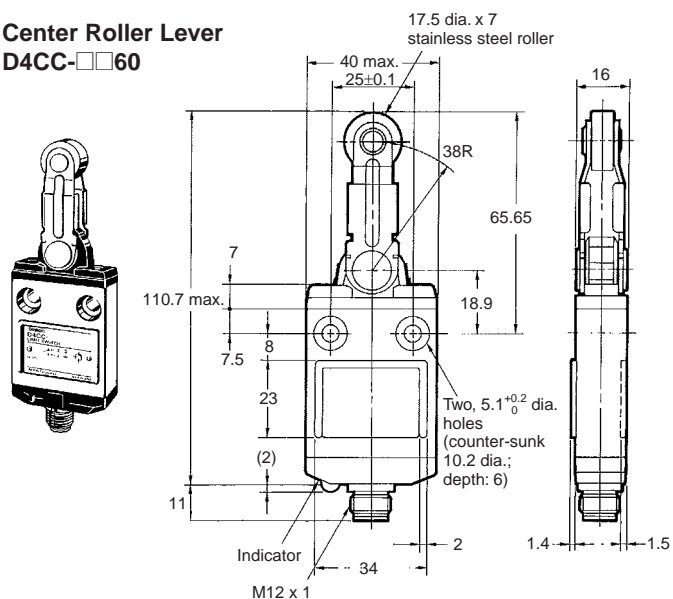

Plugs

XS2F-D421-□80-A (DC)
XS2F-A421-□90-A (AC)
(Straight Type)

Model	Cable length (L)
XS2F-D421-C□-A	1 m
XS2F-D421-D□-A	2 m
XS2F-D421-G□-A	5 m
XS2F-D421-J□-A	10 m

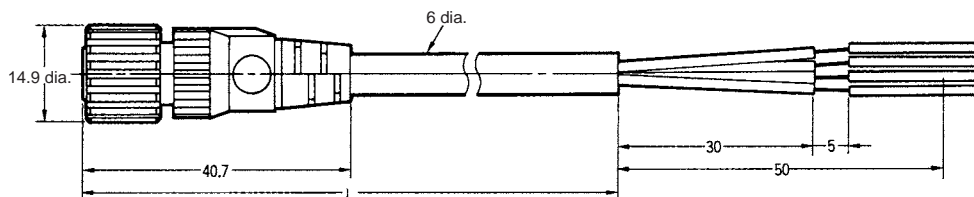
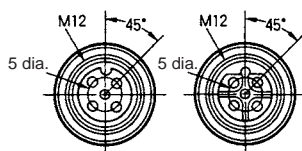
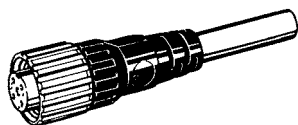

Special Mounting Plates

(Limit Switches are not attached to the Plates.)

D4C-P001 (For D4CC-□001)

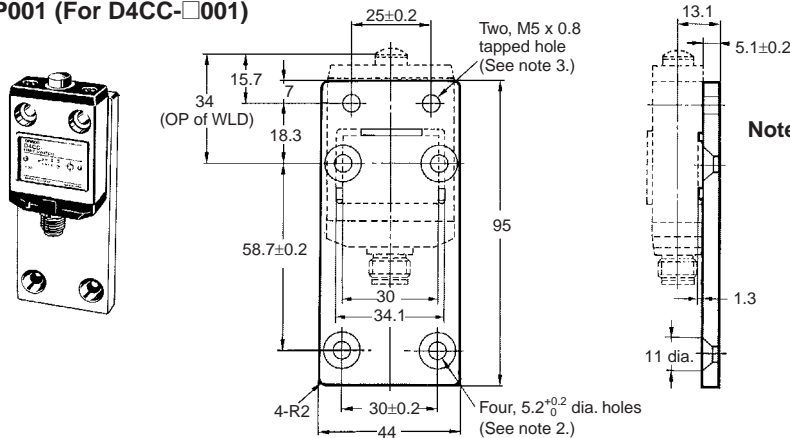

- Note:**
1. Four hexagonal flat head bolts (M5 x 0.8, length: 10) and two Allen-head bolts (M5 x 0.8, length: 15) are included.
 2. All the holes with 5.2^{+0.2}/₀ dia. must be used with M5 x 10 Allen-head bolts.
 3. All the M5-tapped holes must be used with M5 hexagonal flat head bolts.

D4C-P002 (For D4CC-□002)

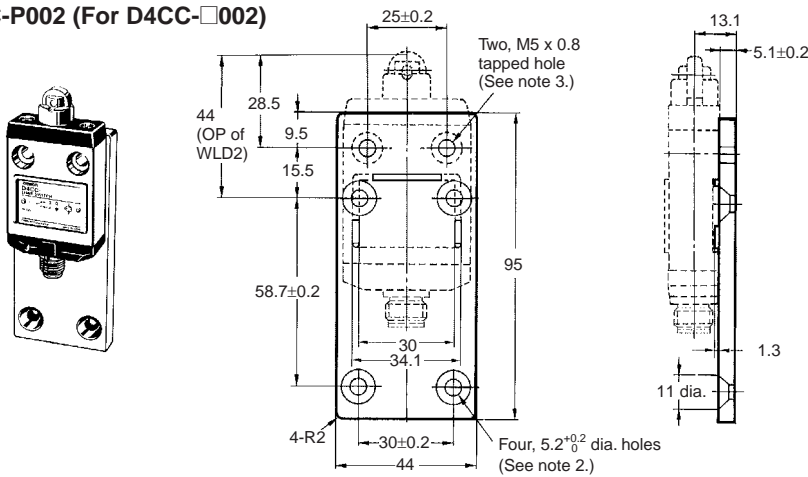

- Note:**
1. Four hexagonal flat head bolts (M5 x 0.8, length: 10) and two Allen-head bolts (M5 x 0.8, length: 15) are included.
 2. All the holes with 5.2^{+0.2}/₀ dia. must be used with M5 x 10 Allen-head bolts.
 3. All the M5-tapped holes must be used with M5 hexagonal flat head bolts.

D4C-P020 (For D4CC-□024)

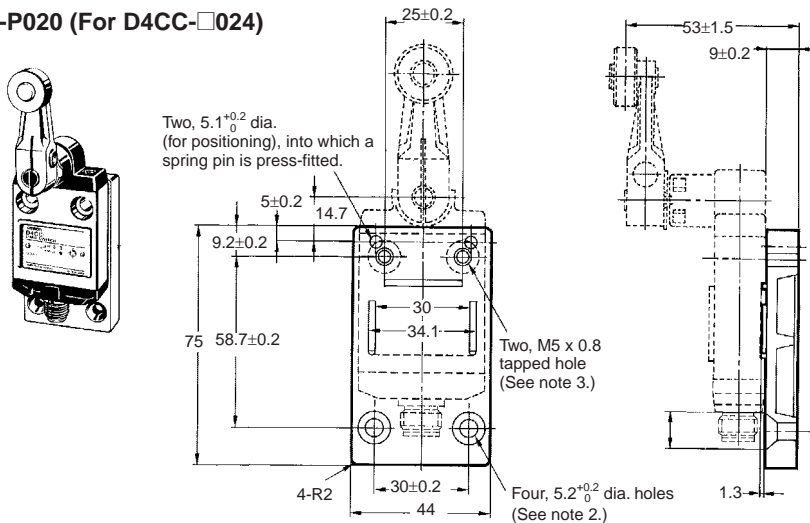

- Note:**
1. Four hexagonal flat head bolts (M5 x 0.8, length: 10), two Allen-head bolts (M5 x 0.8, length: 15), and two spring pins (4 x 14) are included.
 2. All the holes with 5.2^{+0.2}/₀ dia. must be used with M5 x 10 Allen-head bolts.
 3. All the M5-tapped holes must be used with M5 hexagonal flat head bolts.

Precautions

Correct Use

Mounting

Make sure that the plate to which the D4CC is mounted is flat. If the plate is warped or has protruding parts, the D4CC may not malfunction.

Mounting Holes

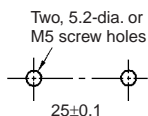

A maximum of 6 Switches may be group-mounted. In this case, pay attention to the mounting direction so that the convex part of the group-mounting guide on one Switch fits into the concave part of the guide on the other Switch as shown in the figure below. For group mounting, the mounting panel must have a thickness (t) of 6 mm min.

Group Mounting

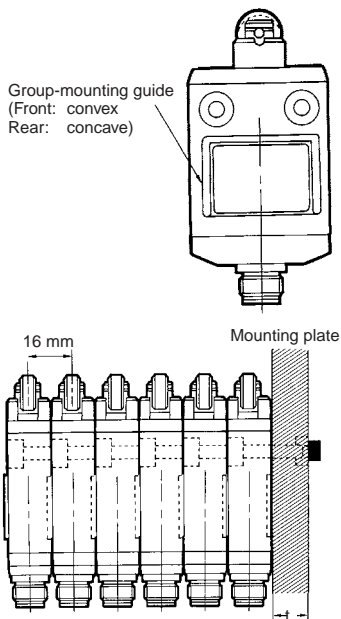

Tightening Torque

Be sure to tighten each screw to the proper tightening torque as shown in the table.

No.	Type	Torque
1	M5 Allen-head bolt	4.90 to 5.88 N·m
2	M3.5 head mounting screw	0.78 to 0.88 N·m
3	M5 Allen-head bolt	4.90 to 5.88 N·m

Note: By removing the two screws from the head, the head direction can be rotated 180°. After changing the head direction, re-tighten to the torque specified above. Be careful not to allow any foreign substance to enter the Switch.

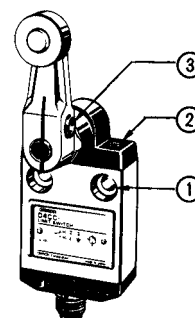

Plug Tightening

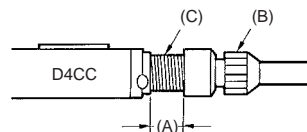

Connect the plug connector (B) to the connector threads of the D4CC. Then firmly turn the plug connector by hand so that the connector threaded portion (C) will be completely covered by the plug connector (B) so that space (A) will be almost 0. Do not use any tools, such as pliers, to tighten the plug connector, otherwise the plug connector may become damaged. Make sure, however, that the plug connector is tightened securely, otherwise the rated degree of protection of the D4CC may not be maintained. Furthermore, the plug connector may be loosened by vibration.

Properly Tightened Connector

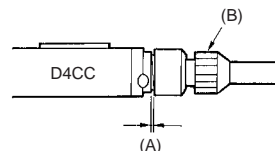

Operation

Operation method, shapes of cam and dog, operating frequency, and overtravel have a significant effect on the service life and precision of a Limit Switch. For this reason, the dog angle must be 30° max., the surface roughness of the dog must be 6.3S min. and hardness must be Hv400 to 500.

To allow the plunger-type actuator to travel properly, adjust the dog and cam to the proper setting positions. The proper position is where the plunger groove fits the bushing top.

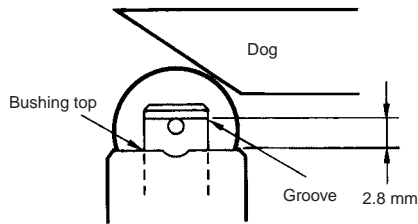

To allow the roller lever-type actuator to travel properly, adjust the dog and cam so that the arrow head is positioned between the two convex markers as shown below.

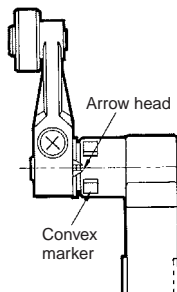

Properly adjust the stroke of the center roller lever along with the dog or cam so that the concave part (A) of the head is located between the convex parts of the head as shown below when the center roller lever is pressed by the dog or cam.

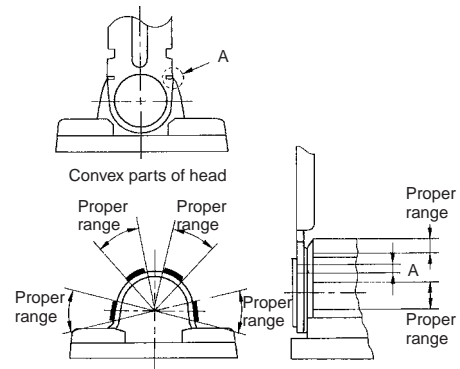

Refer to the following to adjust the stroke of the lever based on the mounting hole level.

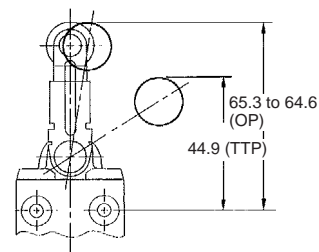

Others

If failures, such as reset failures, in the plunger model are possible, use a model that has a rubber cap.

Do not expose the Switch to water exceeding 70°C or use it in steam.

ALL DIMENSIONS SHOWN ARE IN MILLIMETERS.

To convert millimeters into inches, multiply by 0.03937. To convert grams into ounces, multiply by 0.03527.