

Ultra-flat multi-beam sensor for elevators

F3E

- Ultra-flat 9 mm shape for easy design-in in elevator constructions
- Highest ambient light immunity (200,000 lux) for installations with direct sunlight exposition
- Triple crossing resolution maintained close to zero distance
- Robust aluminum housing
- Ray failure toleration
- Test input
- Built-in amplifier (operation with 10-30 VDC)
- Fulfills requirements of EN81-70

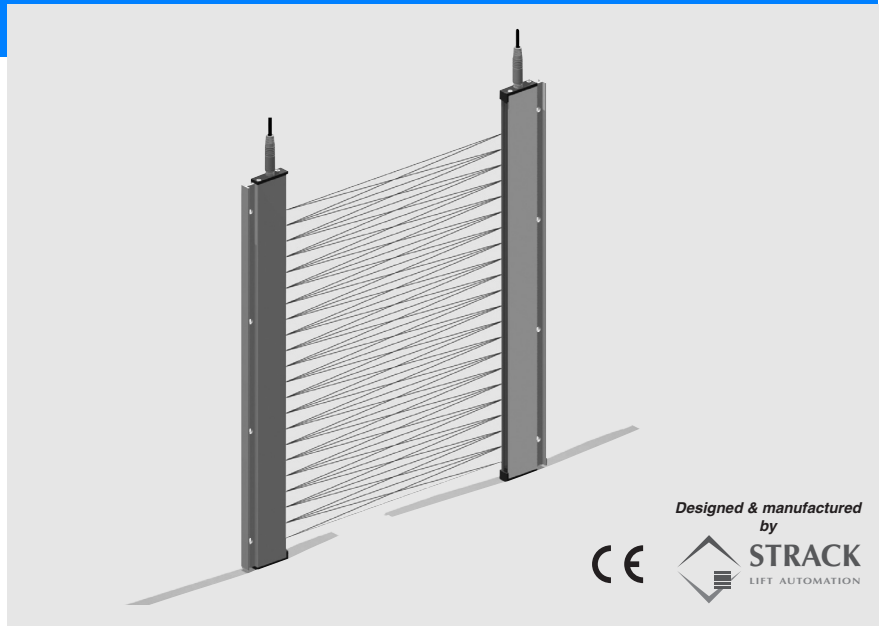

Ordering Information

Pitch	Detection area	channels	Number of optical axis	Connection	Output	Model number
120 mm	1800 mm	16	46	5 m pre-wired	potential-free output	F3E-16-T1 5M
				M8 Connector (4-pin)		F3E-16-T6
40 mm	1800 mm	46	136	5 m pre-wired		F3E-46-T1 5M
				M8 Connector (4-pin)		F3E-46-T6

Features

High reliability and flexibility:

Test input: Function of multi-beam sensor can be tested by transmitter cut off on test signal. A subsequent receiver cut off can be monitored by control unit.

Ray failure toleration: As soon as one channel is not switching for more than 60 seconds, the F3E identifies a defect and deactivates this channel. The sensor then functions normally again showing the defect channel by a red error LED.

Easy parameterization: By test input of transmitter a parameterization of L-ON/D-ON operation and shading of LED areas is possible. No complicated programming or remote control needed

Potential free output: The F3E provides a wear-free electronic relay output for highest connection flexibility and life-time.

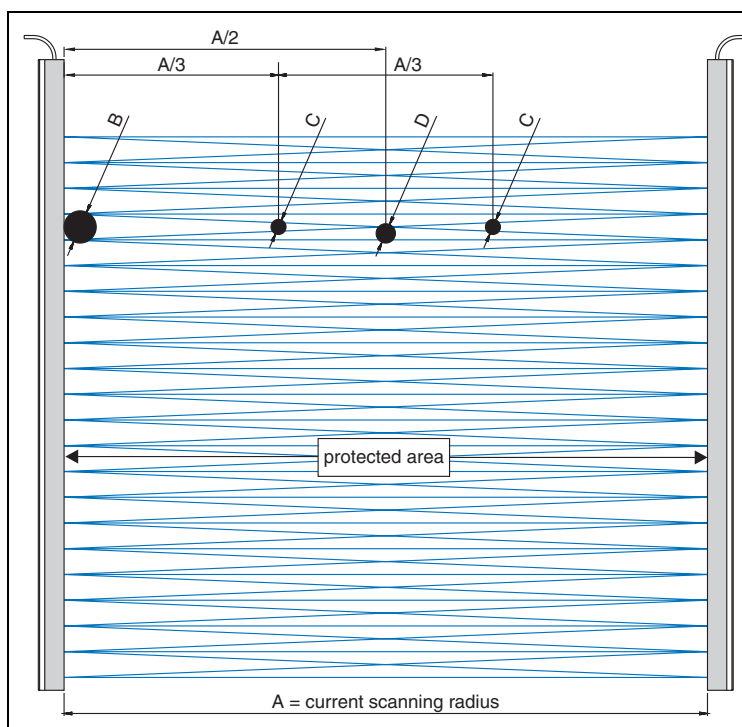

High resolution is realized by *triple crossing of light beams*.

Automatic sensitivity control ensures steady and optimum light power. Even when sensors are operated in dirty environment or at highest distances, no adjustment is necessary. Sensitivity control ensures that the high resolution is maintained at small distances close to "zero".

Min. size of recognized objects:

Pitch	B	D	C
120 mm	125 mm	65 mm	45 mm
40 mm	45 mm	35 mm	18 mm

Rating/Specifications

Item/Type	F3E-16-T[.]	F3E-46-T[.]
Rated sensing distance	0-5 m	
Number LEDs	16	46
Number of optical axis	46	136
Resolution	120 mm	40 mm
Vertical detection area ¹	20-1820 mm	
Response time	max. 110ms (signal interruption)	
Light source (wave length)	Infrared LED (880 nm)	
Power supply voltage	10-30 VDC	
Current consumption	max. 120 mA / pair	max. 240 mA / pair
Control output	Wearless potential free output, 35 V AC/DC max., 150mA max. at 20°C, 100mA max. at 60°C, D-ON (parameterization by emitter test input), max. leakage at open contact 0,001mA, contact resistance 4/12 Ohm	
Test input / light emission stop function	110 ms max. response time	
Ambient light immunity ²	200.000 lux	
Ambient temperature	-20...+60°C (operation) ³ , -40...+70 (storage)	
EMC conformity/standards	73/23/EWG; 89/336/EWG; 95/16/EG; EN81-1; EN81-2; EN12015; EN12016; EN61000-6-x	
Protective degree	IP54	
Connection methods	Pre-wire type (5 m PVC cable), M8-4-PIN	
Indicator LEDs	Emitter: power indicator (yellow); Receiver: output indicator (yellow), output indicator (red)	
Error status indication	Red LED blinking: unstable operation, contamination, max. exceeding sensing distance Red LED ON + yellow LED ON: beam channel defect	
Dimension ¹	2070x40,7x9 mm	2000x40,7x9 mm
Weight	880g (connector version), 1040g (cable version)	
Material	Case	Aluminum
	Cable	PVC

¹ other sizes available on request

² Measured at angle of 20°

³ No icing and condensation

Output circuits

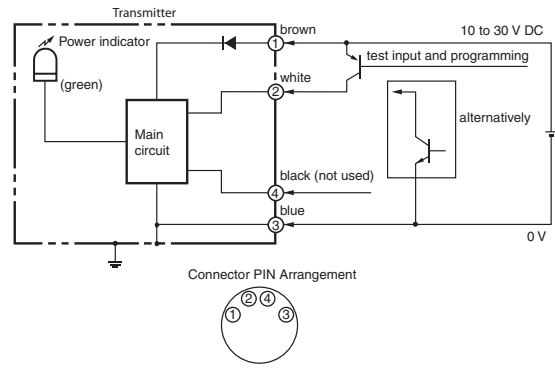
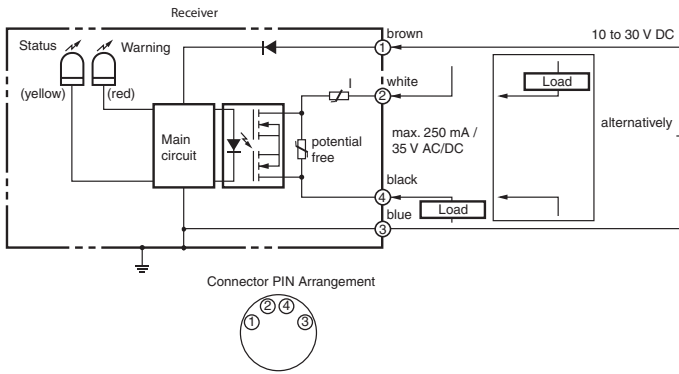

Dimensions

Mounting strap fixation

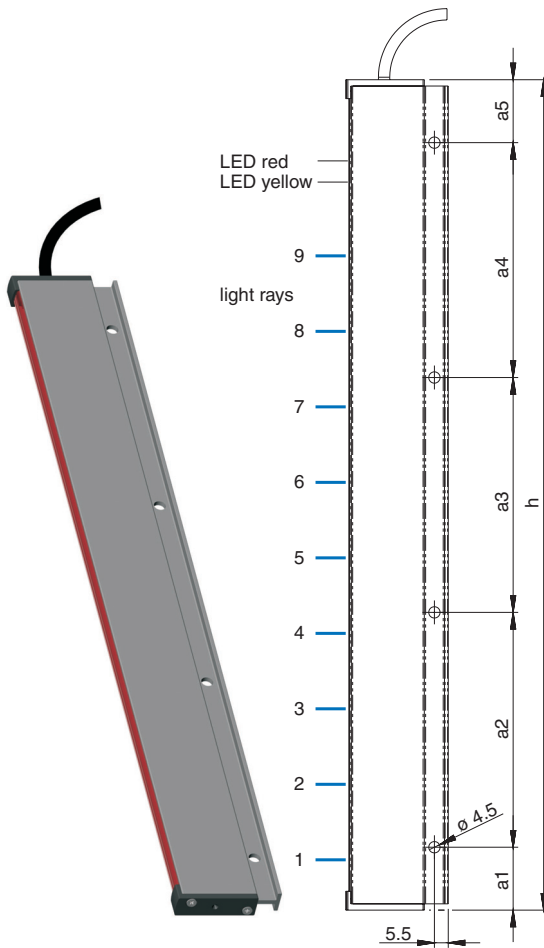

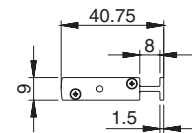

Dimension	F3E-16...	F3E-46...
a5	25 mm	25 mm
a4	690 mm	650 mm
a3	640 mm	650 mm
a2	690 mm	650 mm
a1	25 mm	25 mm
h	2070 mm	2000 mm



Accessories

Cable connectors

	Type	Size	Cable Material	Poles	Length (m)	LED	Nut	Order reference
	slim line straight	M8	PVC	4	5	no	brass	XS3F-M421-405-A
	slim line angled	M8	PVC	4	5	no	brass	XS3F-M422-405-A
	robotic cable straight	M8	PVC	4	5	no	brass	XS3F-M421-405-R
	robotic cable angled	M8	PVC	4	5	no	brass	XS3F-M422-405-R

Note: Complete portfolio of connector types see OMRON Accessory Datasheet

F3E-Accessories

Item	Description	Order reference
F3E-Installation Kit S	Installation kit for stationary mounting on lift doors	F3E-IK-S
F3E-Installation Kit M	Installation kit for mounting to mobile doors panels	F3E-IK-M
F3E-Power supply	Power supply NTR 18/03 for operation with 240VAC/24DC, buzzer function	F3E-PS1

Installation Kit S

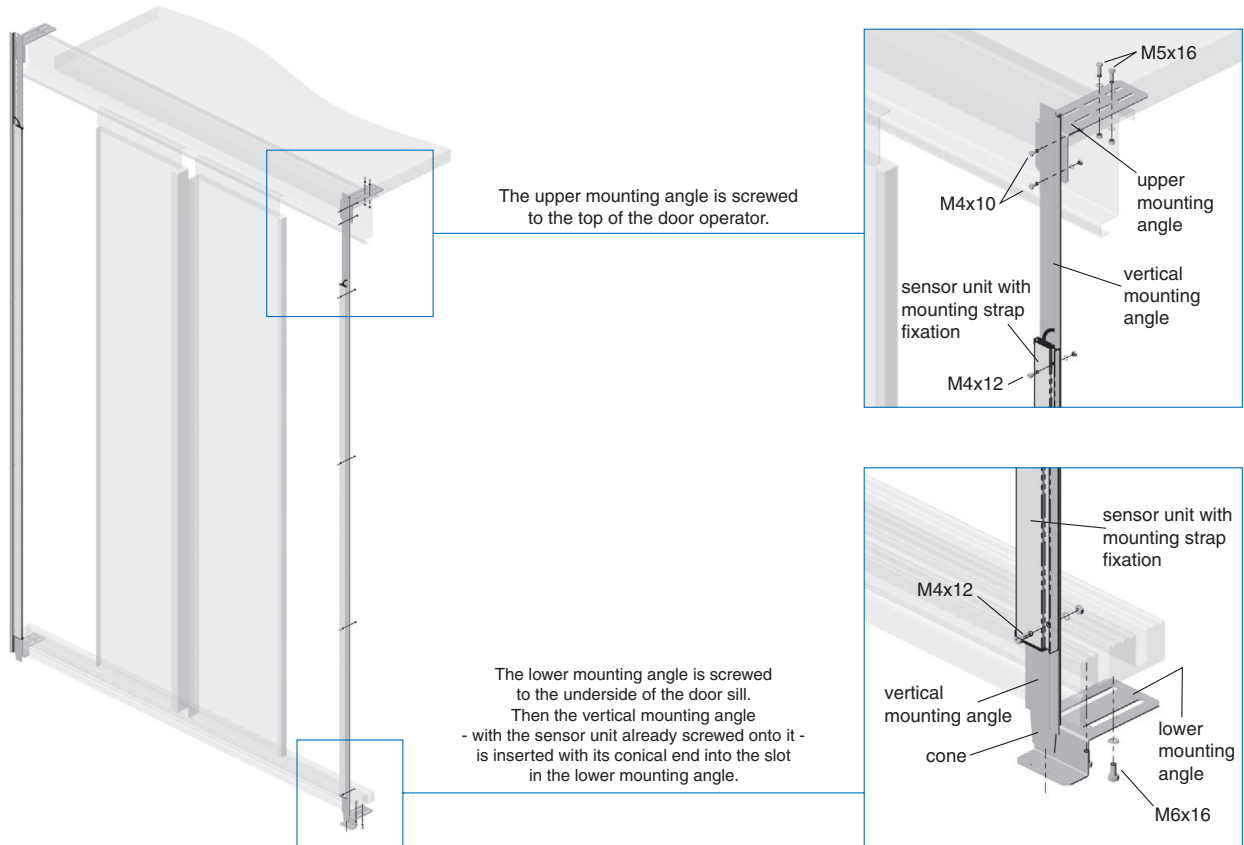

Installation Kit M

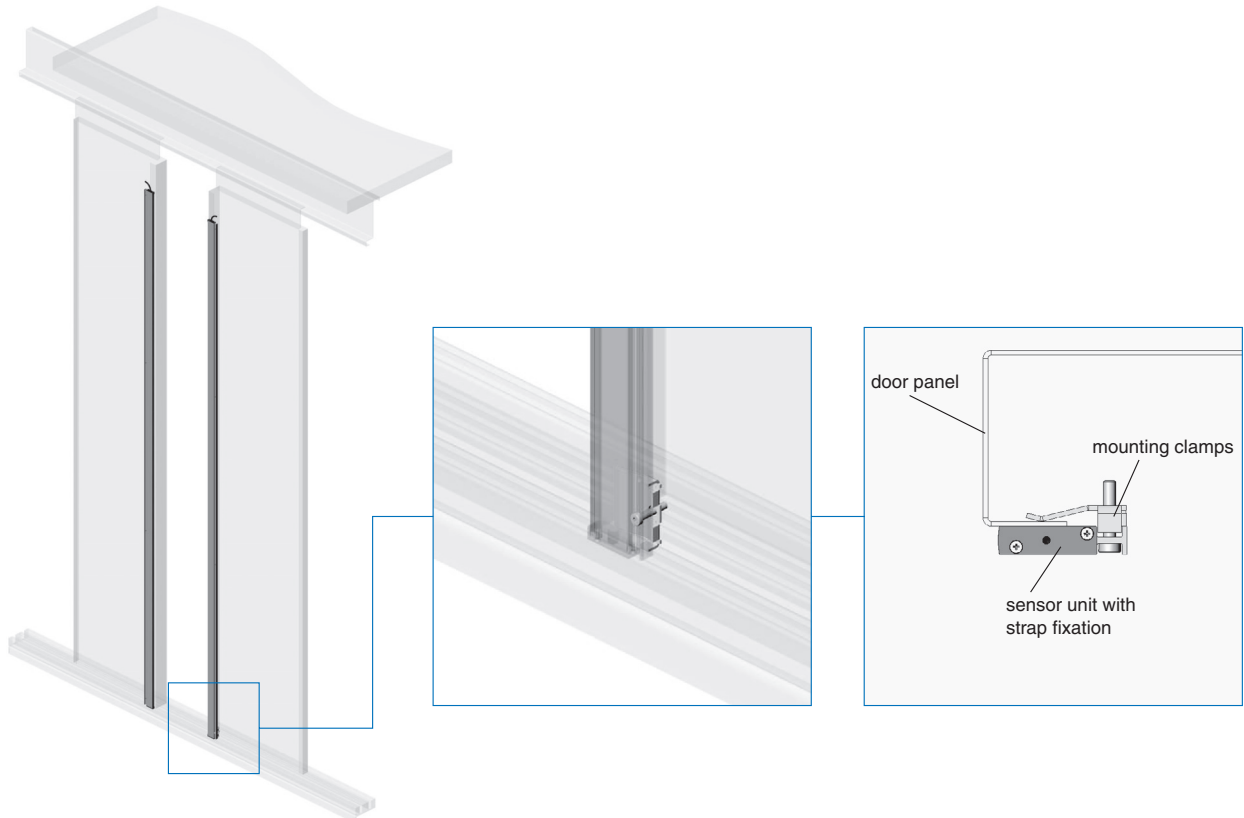

Precautions

⚠ WARNING

The F3E multi-beam sensor is not a safety component for ensuring the safety of people which is defined in EC directive (91/368/EEC) and covered by separate European standards or by any other regulations or standards.

Power Supply Voltage and Output Load Power Supply Voltage

Do not connect an AC power supply to the Sensor. If AC power (100 VAC or more) is supplied to the Sensor, it may explode or burn. Make sure that the power supply to the Sensor is within the rated voltage range. If a voltage exceeding the rated voltage range is supplied to the Sensor, it may explode or burn.

Operating Environment

Do not use the Sensor in locations with explosive or flammable gas. Make sure that the product is operated in accordance with IP54 standards.

Do not subject the multi-beam sensor to excessive shock when mounting.

When you use the multi-beam sensor in the vicinity of an inverter motor, be sure to connect the protective earth ground wire of the motor to earth. Failure to ground the motor may result in malfunction of the sensor.

Mounting the Sensor

Do not strike the Photoelectric Sensor with a hammer or any other tool during the installation of the Sensor.

Cleaning

Never use paint thinners or other organic solvents to clean the surface of the product

M8 Connector

Always turn OFF the power supply to the Sensor before connecting or disconnecting the metal connector. Hold the connector cover to connect or disconnect it.

Secure the connector cover by hand. Do not use pliers; otherwise the connector may be damaged.

If the connector is not connected securely, it may be disconnected by vibration or the proper degree of protection of the Sensor may not be maintained.

Cat. No. E48E-EN-01

In the interest of product improvement, specifications are subject to change without notice.

OMRON EUROPE B.V.

Wegalaan 67-69,
NL-2132 JD, Hoofddorp,
The Netherlands
Phone: +31 23 568 13 00
Fax: +31 23 568 13 88
www.omron-industrial.com