

Multi-Dimensional Sensor Setup Manual

OMRON Corporation
Industrial Automation Company

Application Sensors Division
Sensing Devices and Components Division H.Q.
Shiokoji Horikawa, Shimogyo-ku,
Kyoto, 600-8530 Japan
Tel: (81)75-344-7068/Fax: (81)75-344-7107

Regional Headquarters
OMRON EUROPE B.V.
Sensor Business Unit,
Carl-Benz-Str. 4, D-71154 Nufringen,
Germany
Tel: (49)7032-811-0/Fax: (49)7032-811-199

OMRON ELECTRONICS LLC
1 East Commerce Drive, Schaumburg, IL 60173
U.S.A.
Tel: (1)847-843-7900/Fax: (1)847-843-8568

OMRON ASIA PACIFIC PTE. LTD.
83 Clemenceau Avenue,
#11-01, UE Square,
239920 Singapore
Tel: (65)6835-3011/Fax: (65)6835-2711

OMRON CHINA CO., LTD. BEIJING OFFICE
Room 1028, Office Building,
Beijing Capital Times Square,
No. 88 West Chang'an Road,
Beijing, 100031 China
Tel: (86)10-8391-3005/Fax: (86)10-8391-3688

Authorized Distributor:

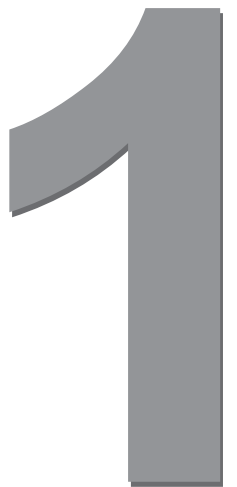
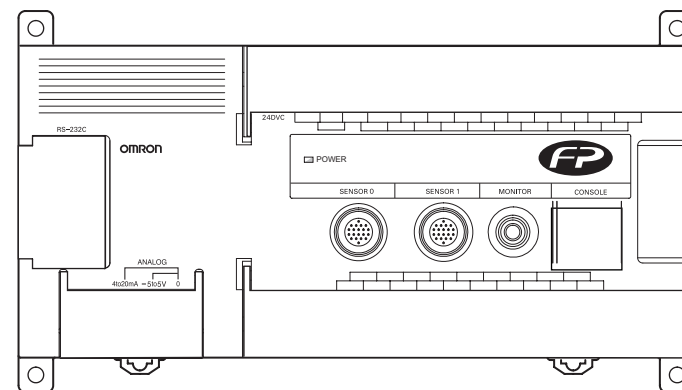

This manual provides information on system hardware. Be sure to read this manual first.

INTRODUCTION

Thank you for your purchase of Z5FP-MC10 (hereinafter referred to as the Controller). This manual explains how to use the Controller. Please observe the following points when using the Controller.

- Please read and understand this manual thoroughly before using the Controller so that it is not used incorrectly.
- Please keep this manual at hand so that you can refer to it at any time.

Operation Procedure and Reference Manual

The following shows main contents of operation steps and manuals. Select the manual suitable for your purpose and read it before starting operation

Installation

Wiring

Setting the Controller and Setting Workpieces in Place

Adjusting Images

Setting Measurement Conditions and Starting Measurement

Outputting Data to External Device

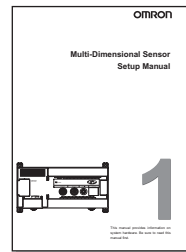

Setup Manual

Contains information on safe use of the unit, series of procedures starting from package content check, installation to cable connection, together with functions and specifications of the unit and its peripheral devices.

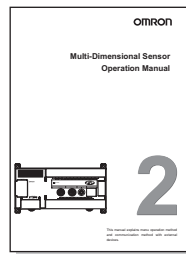

Operation Manual

Explains menu operation method and communication method with external devices.

INTRODUCTION	Precautions in using the Product (Be sure to read it.)	INTRODUCTION
SECTION 1	Wiring and Connection	SECTION 1
SECTION 2	Installation	SECTION 2
SECTION 3	Connecting External Devices	SECTION 3
SECTION 4	Appendix	SECTION 4

Setup Manual

Multi-Dimensional Sensor



Read and Understand this Manual

Please read and understand this manual before storing, installing, programming, operating, maintaining, or disposing of the products. Please consult your OMRON representative if you have any questions or comments.

WARRANTY

OMRON's exclusive warranty is that the products are free from defects in materials and workmanship for a period of one year (or other period if specified) from date of sale by OMRON.

OMRON MAKES NO WARRANTY OR REPRESENTATION, EXPRESS OR IMPLIED, REGARDING NON-INFRINGEMENT, MERCHANTABILITY, OR FITNESS FOR PARTICULAR PURPOSE OF THE PRODUCTS. ANY BUYER OR USER ACKNOWLEDGES THAT THE BUYER OR USER ALONE HAS DETERMINED THAT THE PRODUCTS WILL SUITABLY MEET THE REQUIREMENTS OF THEIR INTENDED USE. OMRON DISCLAIMS ALL OTHER WARRANTIES, EXPRESS OR IMPLIED.

LIMITATIONS OF LIABILITY

OMRON SHALL NOT BE RESPONSIBLE FOR SPECIAL, INDIRECT, OR CONSEQUENTIAL DAMAGES, LOSS OF PROFITS OR COMMERCIAL LOSS IN ANY WAY CONNECTED WITH THE PRODUCTS, WHETHER SUCH CLAIM IS BASED ON CONTRACT, WARRANTY, NEGLIGENCE, OR STRICT LIABILITY.

In no event shall the responsibility of OMRON for any act exceed the individual price of the product on which liability is asserted.

IN NO EVENT SHALL OMRON BE RESPONSIBLE FOR WARRANTY, REPAIR, OR OTHER CLAIMS REGARDING THE PRODUCTS UNLESS OMRON'S ANALYSIS CONFIRMS THAT THE PRODUCTS WERE PROPERLY HANDLED, STORED, INSTALLED, AND MAINTAINED AND NOT SUBJECT TO CONTAMINATION, ABUSE, MISUSE, OR INAPPROPRIATE MODIFICATION OR REPAIR.

SUITABILITY FOR USE

OMRON shall not be responsible for conformity with any standards, codes, or regulations that apply to the combination of the product in the customer's application or use of the products.

At the customer's request, OMRON will provide applicable third party certification documents identifying ratings and limitations of use that apply to the products. This information by itself is not sufficient for a complete determination of the suitability of the products in combination with the end product, machine, system, or other application or use.

The following are some examples of applications for which particular attention must be given. This is not intended to be an exhaustive list of all possible uses of the products, nor is it intended to imply that the uses listed may be suitable for the products:

- Outdoor use, uses involving potential chemical contamination or electrical interference, or conditions or uses not described in this manual.
- Nuclear energy control systems, combustion systems, railroad systems, aviation systems, medical equipment, amusement machines, vehicles, safety equipment, and installations subject to separate industry or government regulations.
- Systems, machines, and equipment that could present a risk to life or property.

Please know and observe all prohibitions of use applicable to the products.

NEVER USE THE PRODUCT FOR AN APPLICATION INVOLVING SERIOUS RISK TO LIFE OR PROPERTY WITHOUT ENSURING THAT THE SYSTEM AS A WHOLE HAS BEEN DESIGNED TO ADDRESS THE RISKS, AND THAT THE OMRON PRODUCTS ARE PROPERLY RATED AND INSTALLED FOR THE INTENDED USE WITHIN THE OVERALL EQUIPMENT OR SYSTEM.

PROGRAMMABLE PRODUCTS

OMRON shall not be responsible for the user's programming of a programmable product, or any consequence thereof.

CHANGE IN SPECIFICATIONS

Product specifications and accessories may be changed at any time based on improvements and other reasons.

It is our practice to change model numbers when published ratings or features are changed, or when significant construction changes are made. However, some specifications of the products may be changed without any notice. When in doubt, special model numbers may be assigned to fix or establish key specifications for your application on your request. Please consult with your OMRON representative at any time to confirm actual specifications of purchased products.

DIMENSIONS AND WEIGHTS

Dimensions and weights are nominal and are not to be used for manufacturing purposes, even when tolerances are shown.

ERRORS AND OMISSIONS

The information in this manual has been carefully checked and is believed to be accurate; however, no responsibility is assumed for clerical, typographical, or proofreading errors, or omissions.

Meanings of Signal Words

The following signal words are used in this manual.



WARNING

Indicates a potentially hazardous situation which, if not avoided, will result in minor or moderate injury, or may result in serious injury or death. Additionally there may be significant property damage.

Meanings of Alert Symbols

The following alert symbols are used in this document.



Cautions to indicate potential laser beam hazard

Laser Safety

WARNING

Do not expose your eyes to the laser radiation either directly or indirectly (i.e., after reflection from a mirror or shiny surface).
The laser radiation has a high power density and exposure may result in loss of sight.



Sensor Head is a Class 3B Laser Product according to EN60825-1 (IEC60825-1) and Class IIIB Laser Product according to FDA (21 CFR1040.10) (see note). This product is meant to be built into final system equipment. Pay special attention to the following precautions for the safe use of the product:

Note: Europe: Class 3B of EN60825-1: 1994 = IEC60825-1: 1993
U.S.A.: Class IIIB of FDA (21 CFR1040.10)

	Z550-SW70
Wavelength	658 nm
Maximum pulse duration	17.5 ms
Cycle	0.5 to 25 ms
Peak power	15 mW max.
Classification	3B

- (1) Use this product as specified in this manual. Otherwise, you may be exposed to hazardous laser radiation.
- (2) This product radiates laser beams in the visible light range. Do not expose your eyes directly to the laser radiation. Ensure that the laser beam path is terminated during use. If a mirror or shiny surface is positioned in the laser beam path, ensure that the reflected beam path is also terminated. If the Unit must be used without terminating the laser beam path, position the laser beam path so that it is not at eye level.
- (3) To avoid exposure to hazardous laser radiation, do not displace nor remove the protective housing during operation, maintenance, and any other servicing.
- (4) The user should return the product to OMRON for all repair and servicing.
- (5) As for countries other than those of Europe and the U.S.A., observe the regulations and standards specified by each country.

As for the Laser Product Classifications, refer to the Appendix.



p.55

■ Labeling on Laser Use

The following warning label is attached to the side of the sensor.

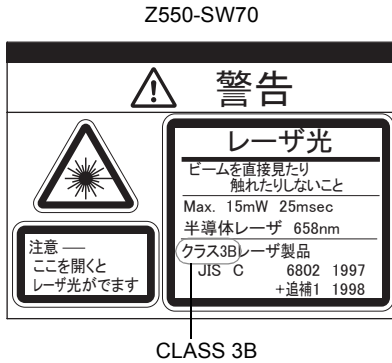

■ Re-labeling

The following labels are provided, to be used selectively according to countries.

for use in the U.S.: FDA label (Aperture label, Caution logo label, Certification and Identification label)

for use in countries other than the U.S.: Warning label according to EN/IEC standards.

Be sure to turn off the sensor before replacing the label, or your hand or other body parts may be exposed to the hazardous laser beam radiating from the sensor.

■ Use in the U.S.

When a laser product mounted on a certain device is to be used in the U.S., it has to meet the requirements set forth by the FDA (regulations for laser products set forth by the Food and Drug Administration).

Applications have been approved by CDRH (Center for Devices and Radiological Health) for Z550-SW70. Three different FDA labels are enclosed in the sensor package. Attach them to the sensor body.

This product is designed to be built into the finished system unit. Refer to the following technical standard for installation.

21CFR1040.10 and 1040.11

FDA Labels for Laser Products

Class III B DANGER logo type

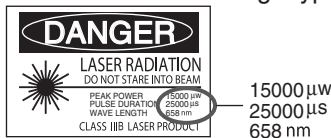

Aperture Label

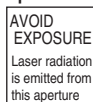

Certification and Identification Label



Be sure to attach FDA labels; do not attach EN/IEC WARNING label by mistake.

Areas to Attach Labels

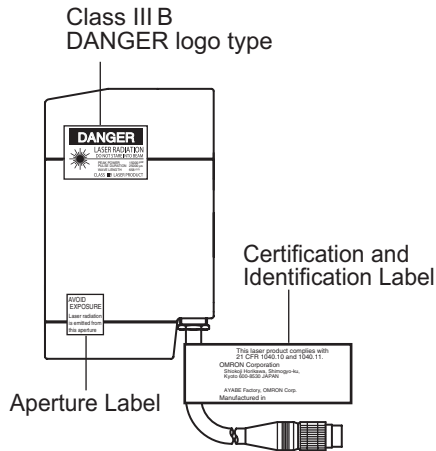

■ Use in Countries Other than the U.S.

Replace the warning label in Japanese on the sensor main body with the attached EN/IEC warning label upon use in countries other than the U.S. Attach the label in the area where the original Japanese warning label was provided.

EN60825-1(IEC60825-1) standard is applied to products exported to European countries. This product conforms to the standard.

EN/IEC Warning Labels

Z550-SW70

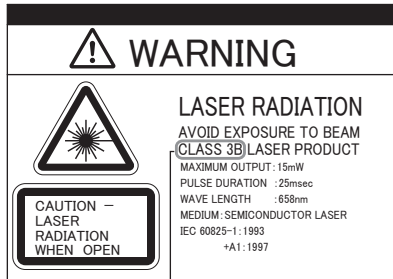

CLASS 3B

Precautions for Safe Use

Please observe the following precautions for safe use of the products.

■ Installation Environment

- Do not use the product in environments where it can be exposed to inflammable/explosive gas.
- Do not install the product close to high-voltage devices and power devices in order to secure the safety of operation and maintenance.

■ Power Supply and Wiring

- Make sure to use the product with the power supply voltage specified by this manual.
- Make sure to use crimp terminals when performing the wiring of the product. Do not simply connect the twisted ends of the wires directly to the terminal block.
- Use a power supply cable and crimp terminals of the specified size.
- Check carefully that the wiring is correct before turning the power supply on.
- Make sure to install the terminal block protection cover after wiring.
- Use a DC power supply with safety measures against high-voltage spikes (safety extra low-voltage circuits on the secondary side) for the power supply to the terminal blocks of the Controller.



- Make sure to tighten all installation screws securely.

■ Other

- Do not disassemble, repair, or modify the product.
- Dispose of this product as industrial waste.

Precautions for Correct Use

Please observe the following precautions to prevent failure to operate, malfunctions, or undesirable effects on product performance.

Installation of the Controller

■ Installation Site

Do not install the Controller in locations subjected to the following conditions:

- Ambient temperature outside the range of 0 to +50°C
- Condensation due to rapid temperature fluctuations
- Relative humidities outside the range of 35 to 85%
- Corrosive or flammable gases
- Dust, salt, or iron particles
- Direct vibration or shock
- Reflection of intense light (such as other laser beams or electric arc-welding machines)
- Strong magnetic fields
- Direct sunlight
- Contact with water, oil, and chemical agents

■ Mounting of the Controller

To improve heat dissipation, install the controller in the following direction only:

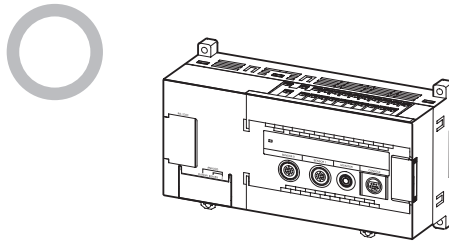

Do not install the controller in the orientations shown in the following diagram.

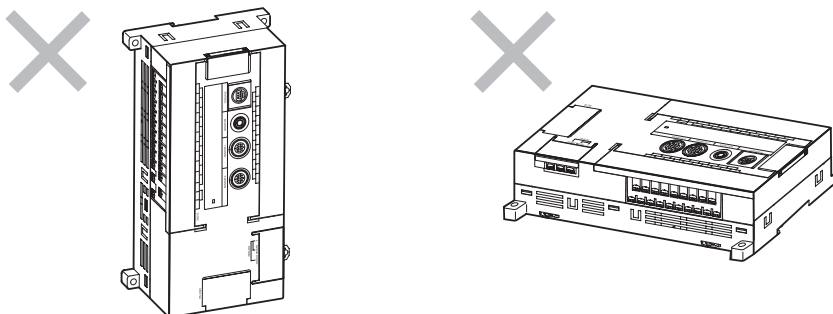

■ Ambient temperature

- Maintain a minimum clearance of 50 mm above and below the Controller to improve air circulation.
- Do not install the Controller immediately above significant heat sources, such as heaters, transformers, or large-capacity resistors.
- Do not let the ambient temperature exceed 50°C.
- Provide a forced-air fan cooling or air conditioning if the ambient temperature is near 50°C so that the ambient temperature never exceeds 50°C.

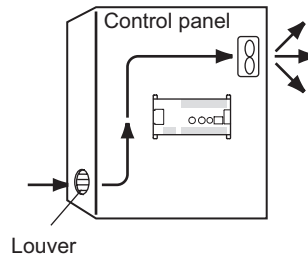

■ Ambient Illumination

- Do not let the ambient illumination exceed 3000 lx.
- When using the Controller near lighting equipment that turns on and off continuously, reduce the influence of the light by, for example, using a light baffle.

■ Noise Resistance

- Do not install the Controller in a cabinet containing high-voltage equipment.
- Do not install the Controller within 200 mm of power cables.

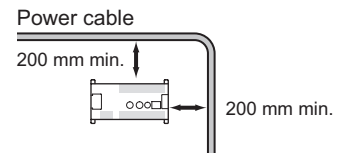

■ Sensor

Install the sensor in a clean environment and keep the optical filter on the front panel of the sensor free from oil and dust. If affected by oil or dust, clean the filter as follows:

- Use a blower brush (normally used to clean camera lenses) to blow large dust particles away from the surface. Do not blow the dust away with your mouth.
- Use a soft cloth (for lenses) with a small amount of alcohol to remove the remaining dust. Never use strong force when wiping the sensor. The filter may become scratched, which can cause errors.

■ When replacing the sensor connected to the Controller:

Turn off the download function when replacing the sensor.

If the sensor is replaced while the download function is on, measurements cannot be taken correctly with the new sensor because the old sensor information (such as the measurement range) is still stored.



Operation Manual p.179

Environment

The sensor cannot detect the following types of objects accurately: Materials with extremely small reflectances, objects with small curvatures, or objects tilted to a large degree

Component Installation and Handling

Dedicated Components

Make sure to use the dedicated components for the sensor and console connected to this controller.

- Sensor: Z550-SW70
- Console: Z300-KP

Connecting/Disconnecting Cables

Always turn the power supply off before connecting or disconnecting any cables.

Touching Signal Lines in Connectors or Terminals

To prevent damage from static electricity, use a wrist strap or another device for preventing electrostatic discharges when touching terminals or signal lines in connectors.

Wiring

When using a transformer for the Controller's driving power supply, use an isolation transformer in the way shown below.

Do not use an auto-transformer. Doing so may result in equipment failure.

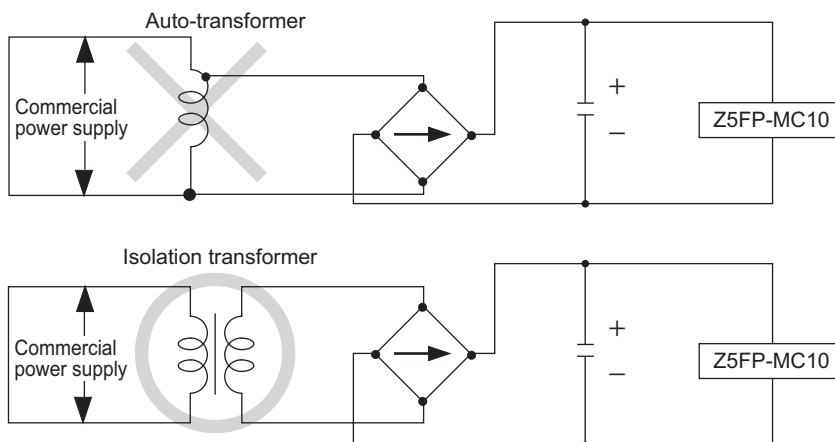

■ Turning off the Power

Do not turn the power supply off while the message indicating that processing is being performed is being displayed. Data in the memory will be destroyed, and the Controller may not operate correctly the next time it is started.

Example: Saving

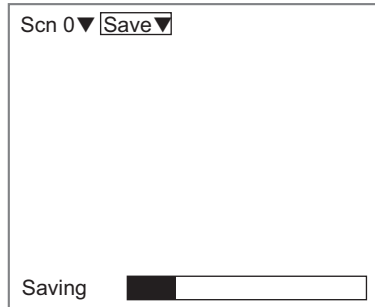

■ Using the RESET Signal

Do not input the RESET signal immediately after power supply is turned on. When using the RESET input to synchronize startup timing, wait at least 1 second after the Controller's power supply is turned on before turning on the RESET terminal.

■ Securing the Video Monitor (When Using the Recommended F150-M09)

If the video monitor case is metallic, observe the following precautions to prevent noise interference, because the video monitor case is connected to the 0V line in the internal circuits.

- Do not ground the video monitor.
- Do not ground the metallic part of the connector.
- Secure the video monitor with plastic screws if it is being mounted to a metallic surface.

■ Warming Up

After turning on the power supply, allow the Controller to stand for at least 30 minutes before use. The circuits are unstable immediately after the power supply is turned on and attempting measurement may result in inconsistent measurement values.

Editor's Note

Visual Aids

NOTICE

Indicates information required to take full advantage of the functions and performance of the product. Incorrect application methods may result in data corruption or damage to the product. Read and follow all precautionary information.

**CHECK!**

Indicates points that are important to achieve the full product performance, such as operational precautions and application procedures.



Indicates where to find related information.





Indicates information helpful in operation.

Table of Contents

INTRODUCTION	1
Precautions in using the Product	2
Wiring and Connection	15
Editor's Note	13
Table of Contents	14
SECTION 1 Wiring and Connection	15
Basic System Configuration	16
Component Names and Functions	17
Wiring Power Supply and Ground	19
SECTION 2 Installation	21
Mounting the Controller	22
Mounting the Sensor	24
SECTION 3 Connecting External Devices	29
Terminal Block Connections	30
RS-232C Connections	34
Linear Sensor Controller Connections	36
SECTION 4 Appendix	41
Troubleshooting	42
Inspection	44
Specifications and Dimensions	45
Laser Product Classifications	55

SECTION 1

Wiring and Connection

 Basic System Configuration	16
 Component Names and Functions	17
 Wiring Power Supply and Ground	19

Basic System Configuration

The following diagram shows the basic Controller system configuration.

NOTICE

- Dedicated products must be used for some of the components. Some of the devices may be damaged if products other than the specified dedicated products are used. These items are indicated with asterisks.
- Always turn the power supply off before connecting or disconnecting cables. The peripheral devices may be damaged if connected or disconnected while the power supply is turned on.

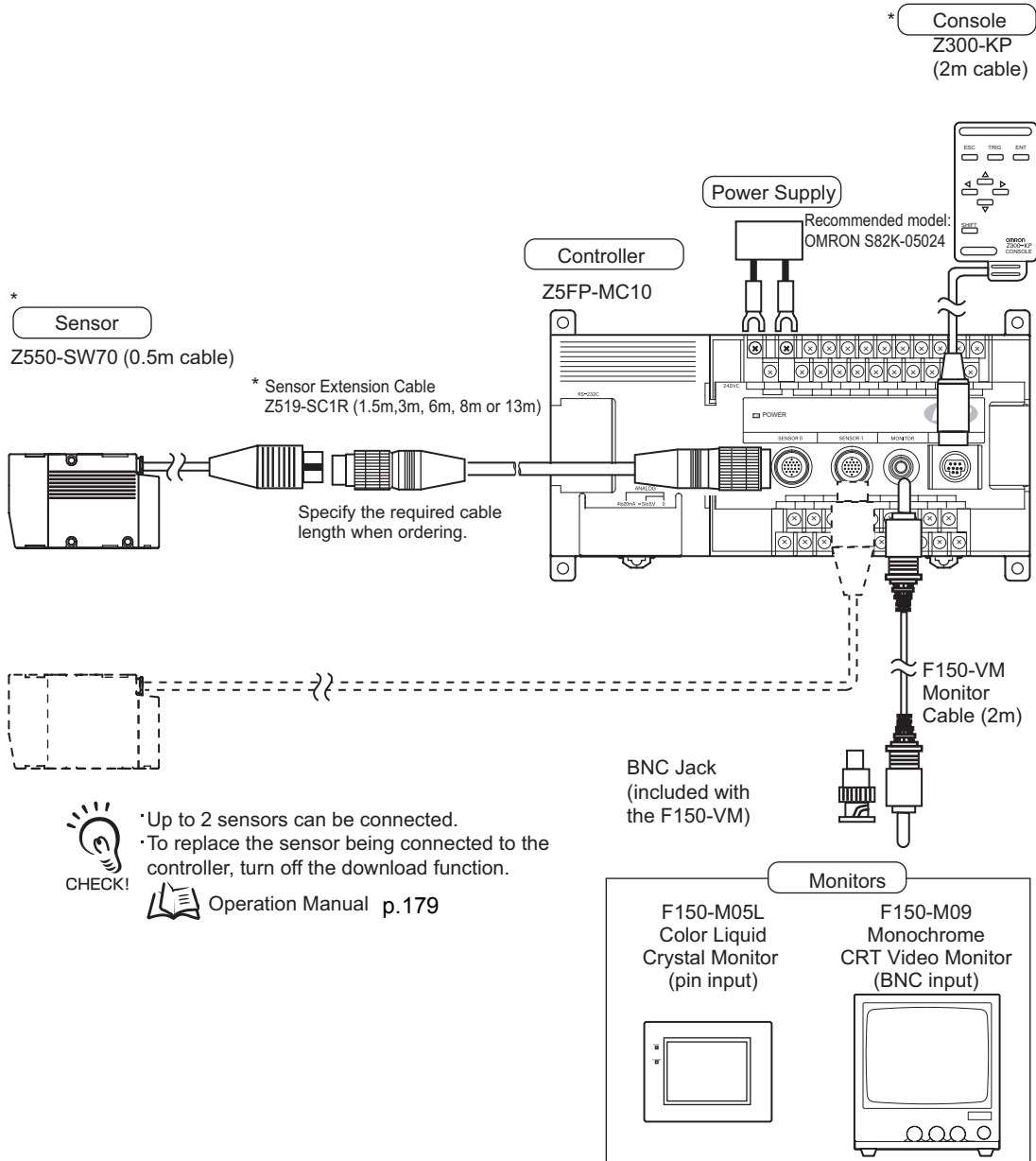

- Up to 2 sensors can be connected.
- To replace the sensor being connected to the controller, turn off the download function.

Operation Manual p.179

The Monitor is used to check the image and display menu where making settings.

Component Names and Functions

Sensor

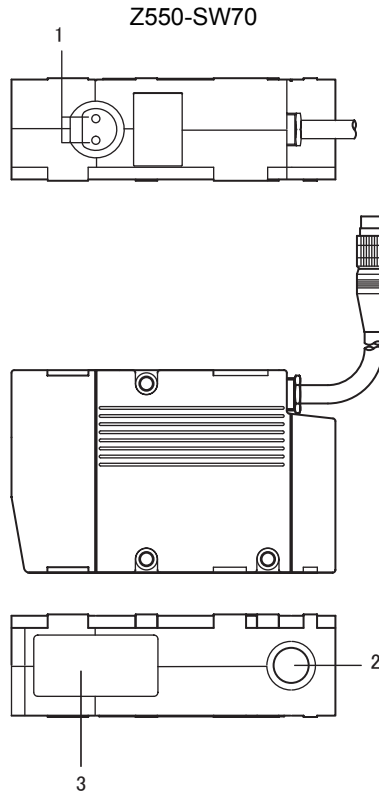

No.	Name	Function
1	Laser beam warning indicators	When the laser beam is turned on, both indicators will turn on. When the laser beam is turned off, both indicators will turn off. For 15 to 25 seconds after the power supply is turned on, both indicators will be off indicating that the laser beam is off.
2	Laser emitter	Emits the laser beam.
3	Laser receiver	Receives the laser beam.

Controller

Z5FP-MC10

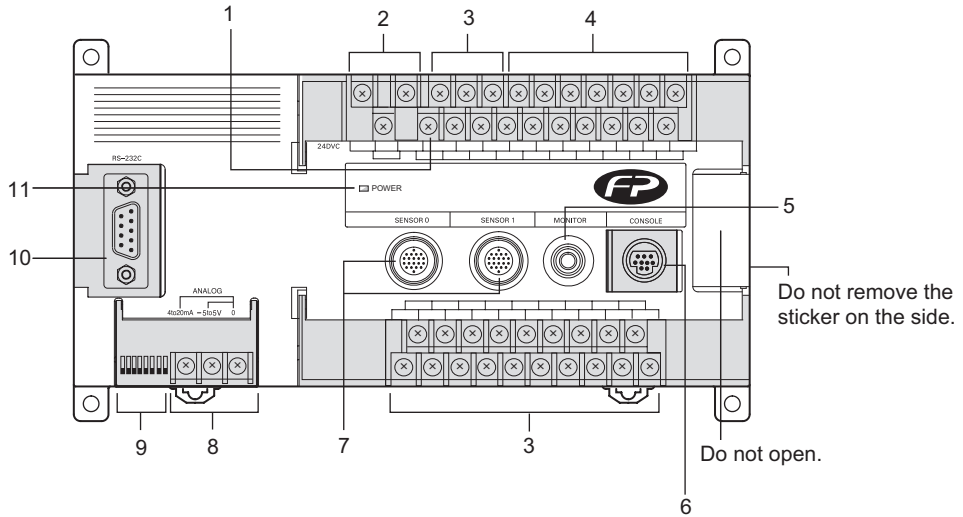

Shading indicates parts that are lifted to see the terminals underneath.

No.	Name	Function
1	Ground wire terminal	Connected to the ground wire.
2	Power supply terminal	Connected to the power supply.
3	Output terminals	Connected to external devices such as a PLC.
4	Input terminals	Connected to external devices such as a PLC.
5	Monitor connector	Connected to the monitor.
6	Console connector	Connected to a console.
7	Sensor connector	Connected to the sensor.
8	Analog output terminals	Connected when using analog output.
9	Dip switch	Used to select the language of the messages displayed on the screen.*
10	RS-232C connector	Connected to external devices such as a personal computer or PLC.
11	POWER indicator lamp	Lit while the power is on.

* Dip switch settings

Switch 1	Switch 2	Switch 3	Switch 4	Switch 5	Switch 6	Switch 7	Switch 8
Always off	Off: Japanese On: English	Always off		Always on	Always off		

Wiring Power Supply and Ground



Wire the power supply and the ground to their respective terminals. Tighten the screws using a torque between 0.5 and 0.6 N·m. After wiring, confirm that the wiring is correct.

NOTICE Reinstall the terminal block protection covers after wiring so that the terminal blocks are covered.

Crimp Terminals and Cables

The terminal block uses M3 terminal screws.
Use appropriate crimp terminals for M3 screws as shown below.

Recommended Model

	Manufacturer	Model	Recommended wire size
Forked 	J.S.T. Mfg Co., Ltd.	V1.25-N3A	1.31 to 1.65 mm ²
Round 	J.S.T. Mfg Co., Ltd.	V1.25-MS3	

Ground Wiring

Always connect a ground wire to the ground terminal of the Controller independently of other devices. To avoid grounding problems, do not share the ground wire with any other devices or wire the ground to the building's steel framing.

Use a grounding point that is as close as possible and keep the ground wiring as short as possible.

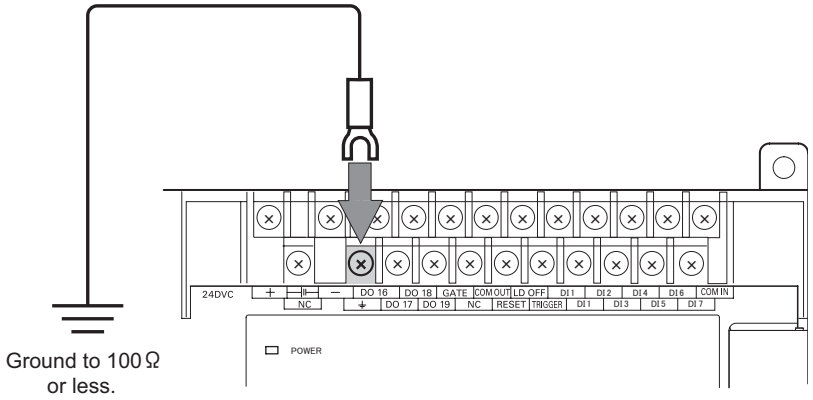

Wiring the Power Supply

Wire the power supply unit independently of other devices. In particular, keep the power supply wired separately from inductive loads.

Use a power supply that meets the following specifications.

Specifications

Output current	Power supply voltage
1.6 A min.	24 V DC (21.6 to 26.4 V DC)

Recommended Model

Manufacturer	Model
OMRON Corporation	S82K-05024



- Use a DC power supply with safety measures against high-voltage spikes (safety extra low-voltage circuits on the secondary side).
- Use a UL class II DC power supply if UL recognition is required in the entire system.
- Keep the power supply wiring as short as possible.

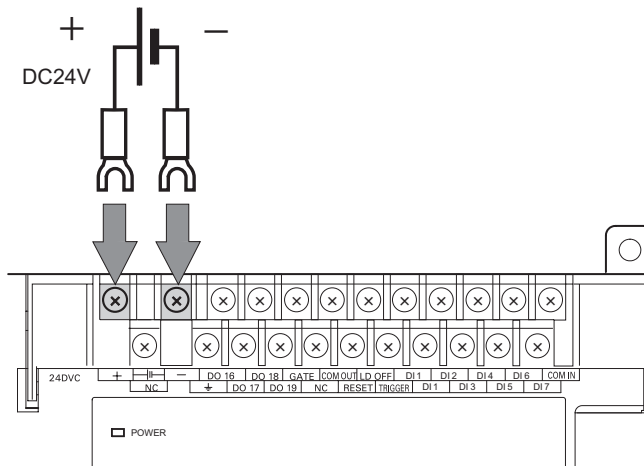

SECTION 2

Installation

 Mounting the Controller	22
 Mounting the Sensor	24

Mounting the Controller

There are two ways to mount the controller: DIN track mounting or surface-mounting.

DIN Track Mounting

The controller can easily be mounted on or removed from a 35-mm width DIN track.

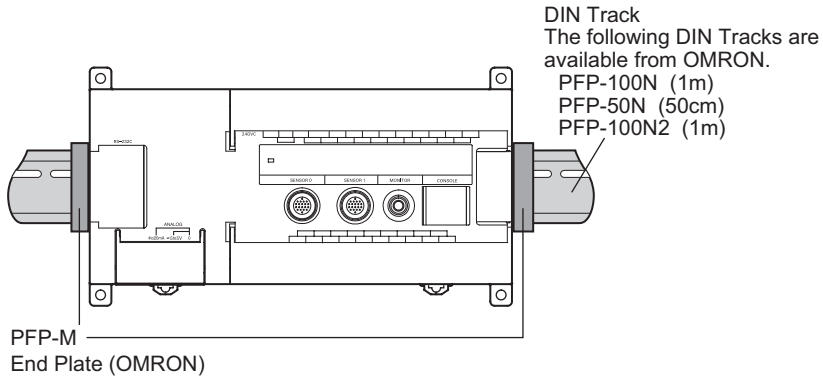

Mounting the Controller

Hook the controller into the DIN track as shown in the diagram and then press in at the bottom until the controller locks into place.

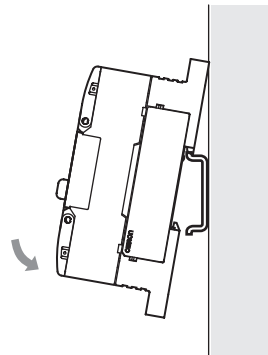

Removing the Controller

Use a flat-bladed screwdriver to pull the hook down and then pull out the controller from the bottom.

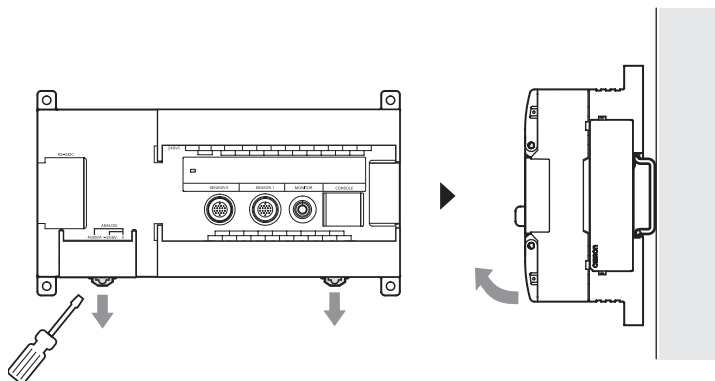

Surface-Mounting

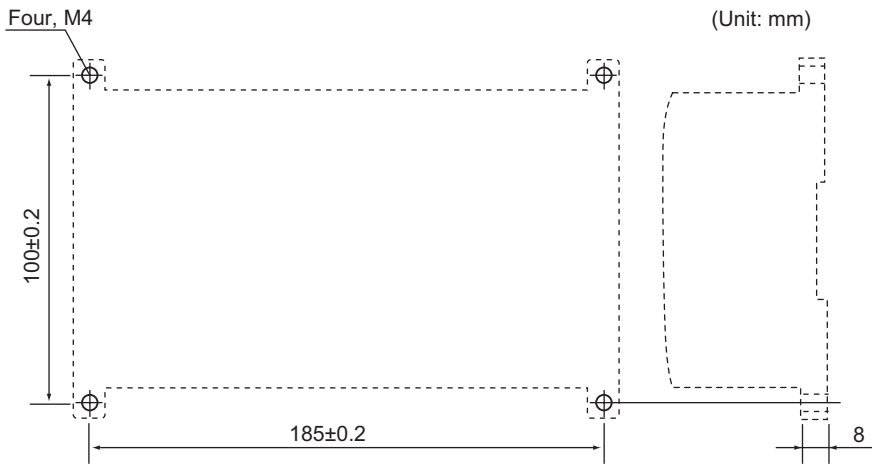

Mounting the Sensor

⚠ WARNING

Do not expose your eyes to the laser radiation either directly or indirectly (i.e., after reflection from a mirror or shiny surface).

The laser radiation has a high power density and exposure may result in loss of sight.



NOTICE

Only controllers designed specifically for the Controller can be used. Using another type of controller may result in damage to the sensor or controller.

Mounting Direction

Mounting Near Walls

If the sensor receives light reflected from a wall surface, it cannot perform the measurement accurately. The sensor should be mounted in the way shown below if it is not possible to mount it away from the wall, i.e., such that the plane containing the emission axis and the reception axis is parallel to the wall surface, preventing interference from light reflected from the wall surface. Also, applying matt black coating to the wall surface will help to reduce the amount of light reflected.

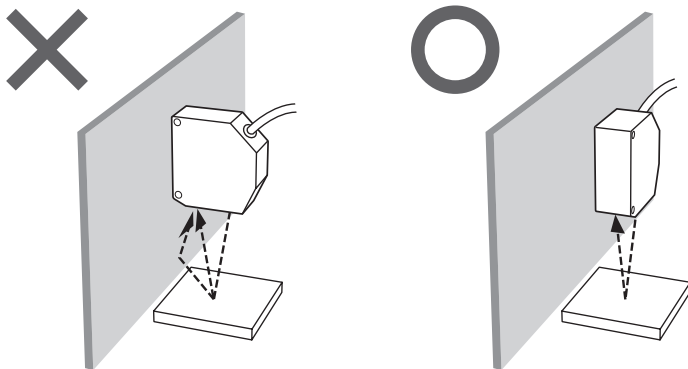

Narrow Grooves or Indentations

If the workpiece to be measured is surrounded by indented internal walls or located in a narrow groove area, mount the sensor in such a way that the emission axis and the reception axis are not blocked by the internal walls.

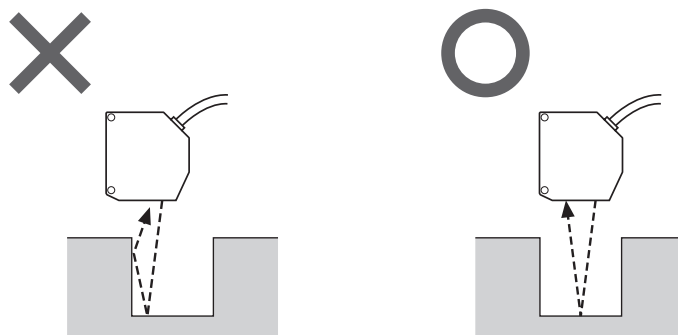

Measurement range

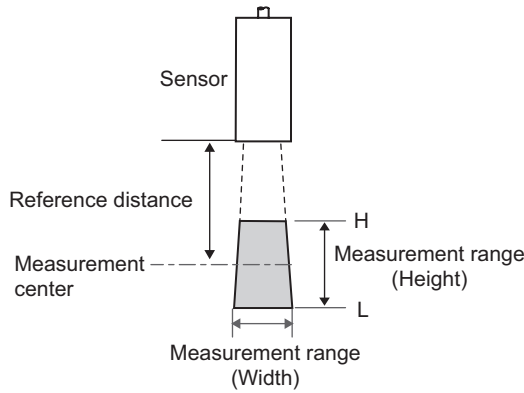

Z550-SW70 (Installation is possible for diffuse reflection only. Installation for regular (mirror) reflection is not possible.)

Measurement range	Reference distance (Diffuse reflection)	Measurement range Direction of height	Measurement range Width direction (H side)	Measurement range Width direction (L side)
10mm	178mm	10mm	62mm	65mm
30mm	192mm	30mm	63mm	72mm
60mm	210mm	60mm	64mm	81mm
100mm	230mm	100mm	64mm	92mm
160mm	260mm	160mm	64mm	109mm
240mm	300mm	240mm	64mm	132mm

NOTICE

Select a mounting condition of the sensor in [System/Environment] from the menu, and then mount the sensor at a distance where it can accurately measure workpieces.

NOTICE

If the connector chassis of a sensor or extension cable makes contact with a noise source, operation may not proceed normally. Insulate the connector chassis before use.

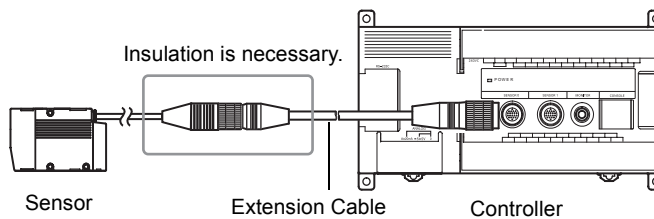

Mutual Interference

When using two or more sensors mounted adjacently, make sure that the spots (shown below) produced by other sensors are outside the shaded areas.

Z550-SW70

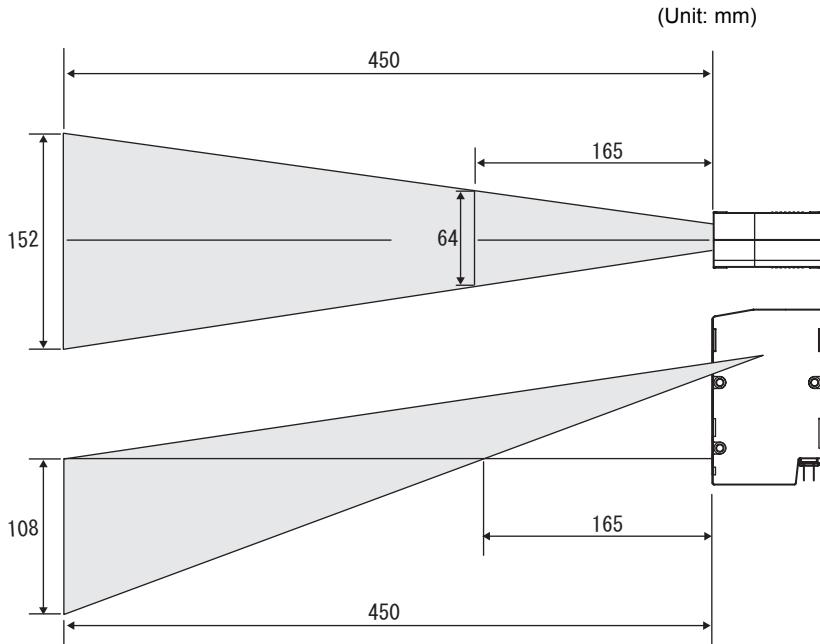

Mounting Hole Dimensions

Z550-SW70

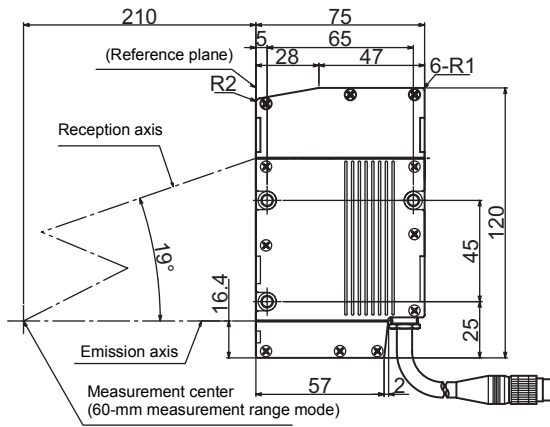

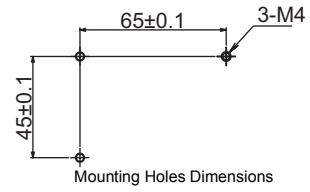

(Unit: mm)



MEMO

SECTION 3

Connecting External Devices

 Terminal Block Connections	30
 RS-232C Connections	34
 Linear Sensor Controller Connections	36

Terminal Block Connections

Measurement command signals are input and measurement results are output via the terminal blocks of the Controller.

This section explains how to connect the terminal blocks to the Controller.

Refer to the separate volume, Operation Manual, for details on I/O formats.

NOTICE



Reinstall the terminal block protection covers so that the terminal blocks are covered after wiring.

Crimp Terminals and Cables

The terminal blocks use M3 terminal screws.

Use appropriate crimp terminals for M3 screws as shown below. Tighten the terminal screws securely using a torque between 0.5 and 0.6 N·m.

Recommended Model

	Manufacturer	Model	Recommended wire size
Forked 	J.S.T. Mfg Co., Ltd.	V1.25-N3A	1.31 to 1.65 mm ²
Round 	J.S.T. Mfg Co., Ltd.	V1.25-MS3	

Internal Specifications

NOTICE Use a DC power supply with safety measures against high-voltage spikes (safe extra low-voltage circuits on the secondary side).

Input Specifications

Input voltage	12 to 24 V DC \pm 10%
ON current	5 to 15 mA
ON voltage	8.8 V max.
OFF current	0.1 mA max.
OFF voltage	4.5 V min.
ON delay	RESET input: 10 ms max.
	Other inputs: 0.5 ms max.
OFF delay	RESET input: 15 ms max.
	Other inputs: 0.7 ms max.
Internal circuit	

Output Specifications

Output voltage	12 to 24 V DC \pm 10%
Load current	45 mA max.
ON residual voltage	2 V max.
OFF leakage current	0.1 mA max.
Internal circuit	

Terminal Names

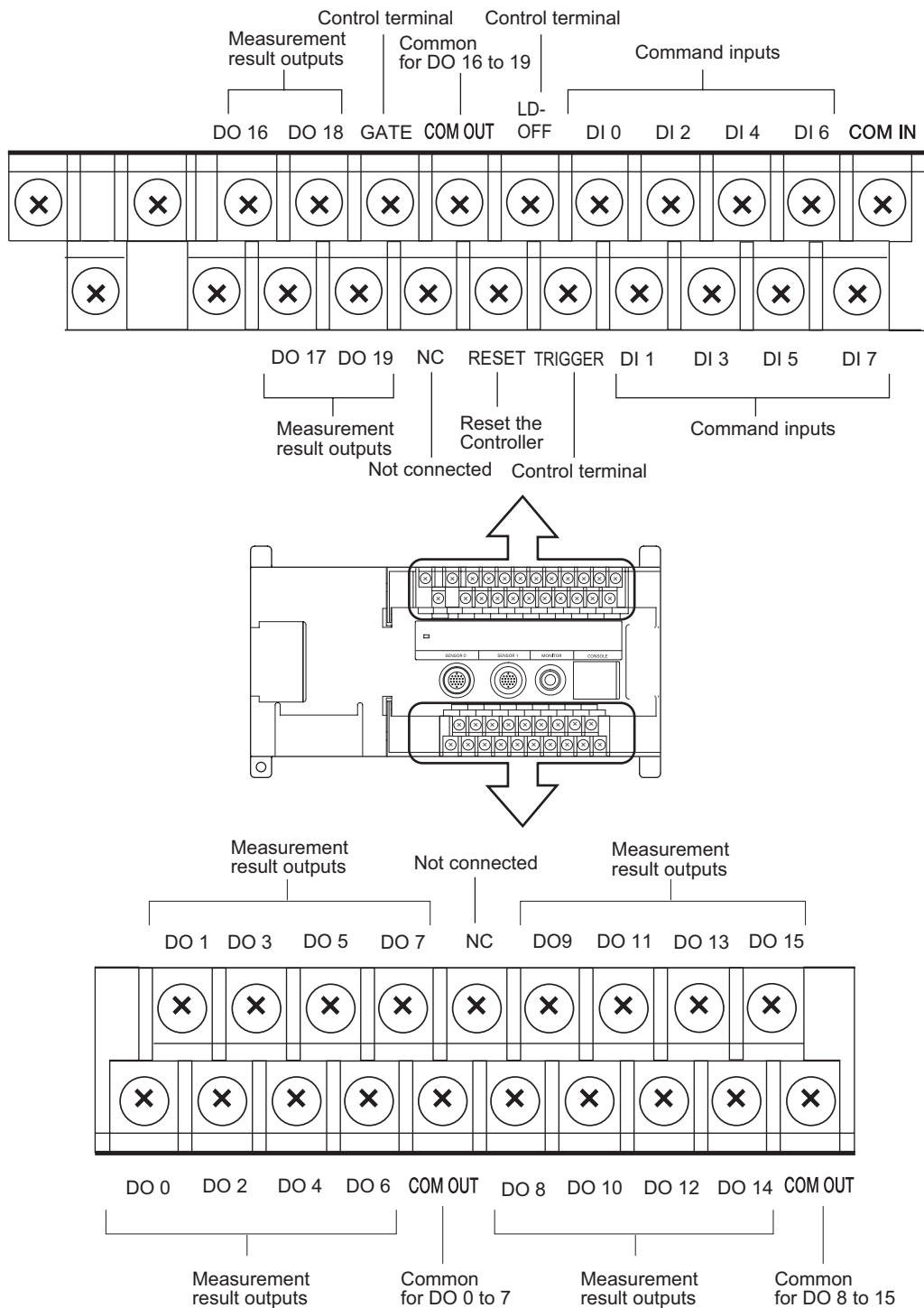



CHECK!

Refer to the separate volume, Operation Manual, for the role of each terminal.

NOTICE

- Do not reverse the connections of the signal terminals and COM terminals.
- RESET Terminal

Do not input the RESET signal immediately after turning the power supply on. When using the RESET signal to synchronize the startup timing, wait at least 1 second after turning the Controller's power supply on before turning the RESET terminal on.



CHECK!

The initial status of the output terminals is off. The terminals may turn on for approximately 0.5 seconds when the power supply is turned on, however. Make sure that these outputs are not treated as actual signals by external devices.

RS-232C Connections

The RS-232C port of the Controller can be used to connect input signals such as measurement triggers or output signals such as measurement results. Additionally, data that has been set in the Controller can be backed up in a personal computer. This section explains how to establish an RS-232C connection. Refer to the separate volume, Operation Manual, for details on communication specification settings and I/O formats.



CHECK!

In some situations, the RS-232C terminal transmits signals when the power supply is turned on or off, or reset.

Make sure that these signals are not treated as actual signals by external devices.

Connector

The Controller's RS-232C connector uses a 9-pin D-SUB female connector. The pins are arranged as follows.

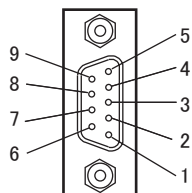

Pin No.	Signal name	Function
1	FG (GND)	Protective frame ground
2	SD (TXD)	Transmission data
3	RD (RXD)	Reception data
4	RS (RTS)	Request to send
5	CS (CTS)	Clear to send
6	NC	Not connected
7	NC	Not connected
8	NC	Not connected
9	SG (GND)	Signal ground

Use a compatible connector.

Recommended Model

	Manufacturer	Model
Plug	OMRON Corporation	XM2A-0901
Hood	OMRON Corporation	XM2S-0911

Wiring

The maximum cable length is 15 m.

Standard

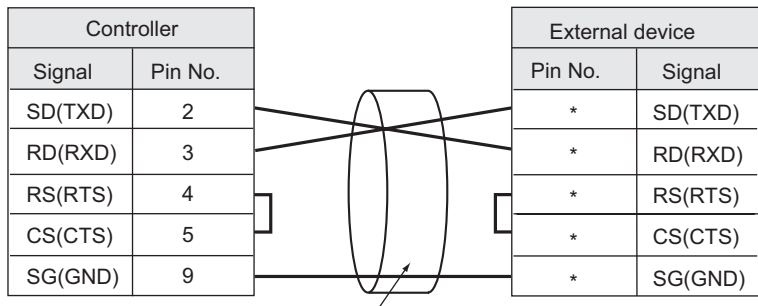

Use a shielded cable.

Wiring for RS/CS Control

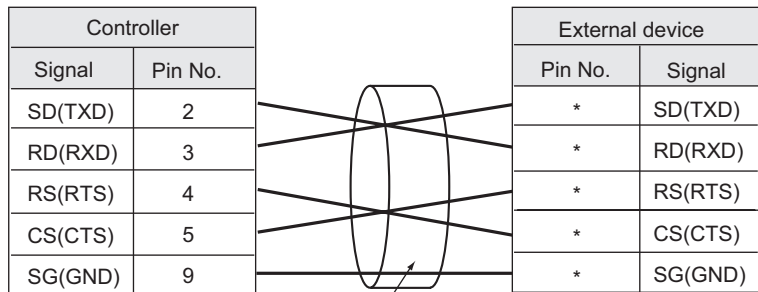

Use a shielded cable.

*Pin numbers on the external device will depend on the device being connected. Refer to the manual for the personal computer or PLC being connected.

Connection Method

Align the connector with the socket and press it straight into place, then fix it with the screws on both sides of the connector.

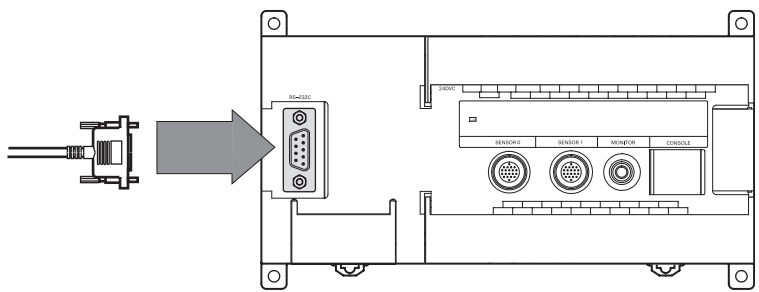

NOTICE

- Turn the power supply off when connecting or disconnecting a cable. Failure to do so may cause damage to peripheral devices.
- Always tighten the connector screws securely.



Linear Sensor Controller Connections

Crimp Terminals and Cables

The terminal blocks use M3 terminal screws.

Use appropriate crimp terminals for M3 screws as shown below. Tighten the terminal screws securely using a torque between 0.5 and 0.6 N·m.

Recommended Model

	Manufacturer	Model	Recommended wire size
Forked 	J.S.T. Mfg Co., Ltd.	V1.25-N3A	1.31 to 1.65 mm ²
Round 	J.S.T. Mfg Co., Ltd.	V1.25-MS3	

Terminal Names

NOTICE

Reinstall the terminal block protection covers so that the terminal blocks are covered after wiring.

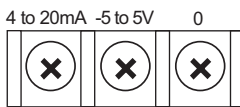
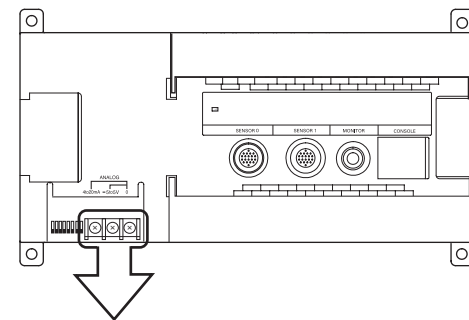

— Analog output ground connected to input devices.

— Analog output terminal for voltage output in the range -5 to 5 V.

— Analog output terminal for current output in the range 4 to 20 mA.

Internal Specifications

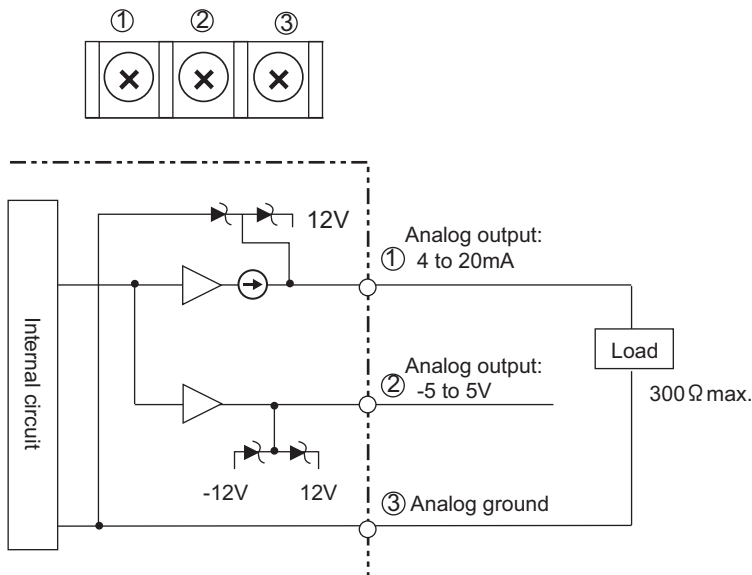

Connection Examples for the Linear Sensor Controller

Connecting to the Linear Sensor Digital Panel Meter (K3TS)

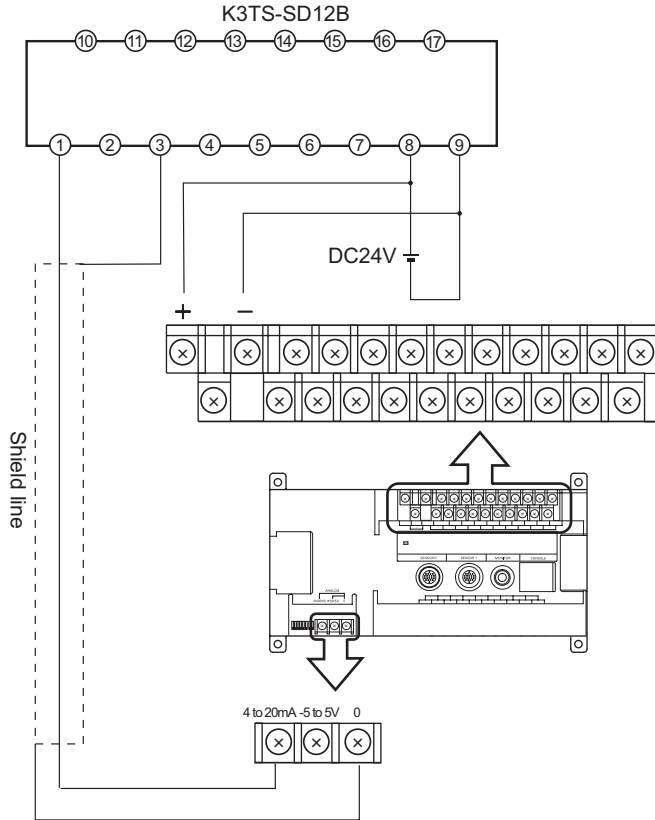

■ Connecting to the Linear Sensor Controller (K3AS)

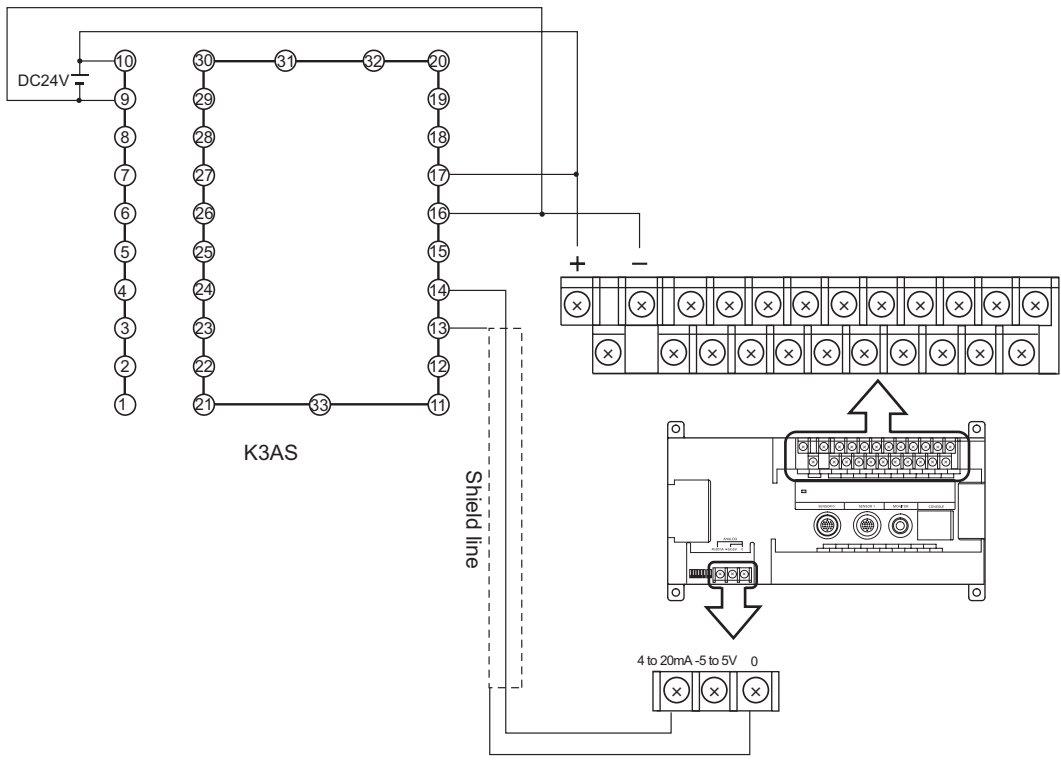

■ Connecting to the Scaling Meter (K3TJ)

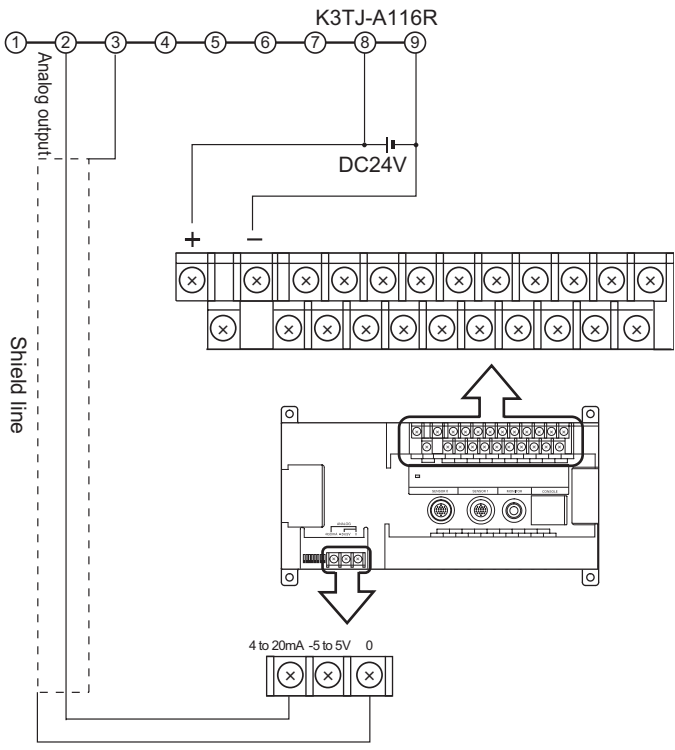

■ **Connecting to the Digital Panel Meter (K3NX)**

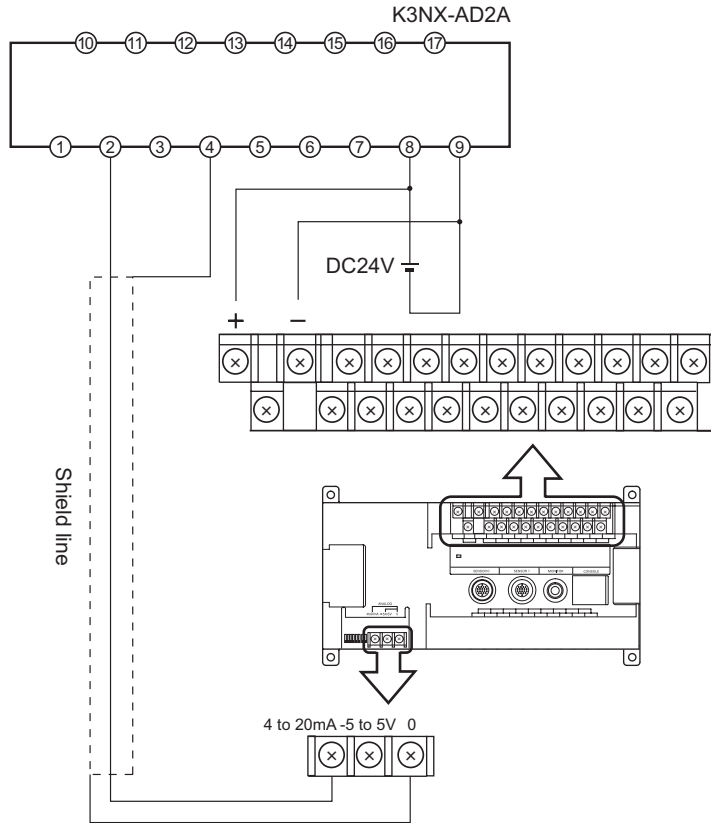



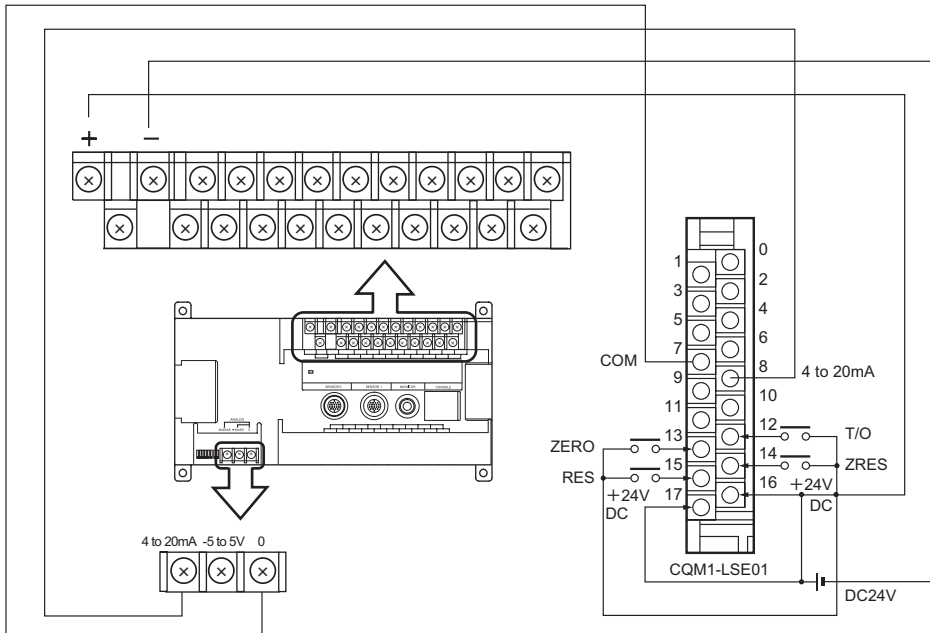

■ **Connecting to the Linear Sensor Interface Unit (CQM1-LSE)**



SECTION 4

Appendix

 Troubleshooting	42
 Inspection	44
 Specifications and Dimensions	45
 Laser Product Classifications	55

Troubleshooting

This section provides information on hardware errors and temporary remedies to be taken. Refer to this section before requesting service from your OMRON representative.



Connection Errors

Problem	Probable cause	Reference
The Power indicator does not light up.	The power supply is not connected properly.	p.19
	The 24 V DC (21.6 to 26.4 V DC) supply voltage has dropped.	
The video monitor is blank.	The power supply to the video monitor is not turned on.	p.16
	The monitor cable is not connected properly.	
	The video monitor is malfunctioning.	
	(In the case of a liquid crystal display monitor) The capacity of the power supply is insufficient.	
The video monitor image is not clear.	There is electric noise entering from the power supply or cables.	-
	The monitor cable is not connected properly.	
Cannot make key inputs from the console.	The console cable is not connected correctly.	p.16
No image is displayed.	The sensor cable is not connected correctly.	p.16
	There is no workpiece inside the measurement range.	p.25
	The sensor is not mounted in the correct position.	



Sensor Errors

Problem	Probable cause	Reference
The measurement range is different from that of the sensor specification.	When you replaced the sensor connected to the controller, did you turn off the download function?	(Operation) p.179

 Terminal Block Errors

Problem	Probable cause	Reference
Trigger signals (input signals) are not received.	The cables are not wired correctly.	p.30
	The signal line is disconnected.	
	The Controller is not in the Run mode.	
Signals cannot be output externally.	The trigger signal has not been input.	p.30
	The cables are not wired correctly.	
	The signal line is disconnected.	
	The Controller is not in the Run mode.	

 RS-232C Communication Errors

Problem	Probable cause	Reference
No communication is possible.	The cables are not wired correctly.	p.34
	The communication specifications of the Controller do not match those of the external device.	
	The Controller is not in the Run mode.	
The unit operates well initially, but after a while there is no response from the Controller.	The buffers on the receiving side (PC) are full. Check wheter they are set to receive data properly.	-

Inspection

In order to ensure the optimal performance of the Controller, carry out the maintenance procedures given below.

NOTICE

- Turn the power supply off and take safety precautions before conducting inspections.
- Do not use thinners or benzene to clean the Controller.

Cleaning

Optical Filter on Front Panel of Sensor

Use a blower brush (normally used to clean camera lenses) to blow large dust particles away from the surface. Do not blow the dust away with your mouth.

Use a soft cloth (such as a lens cleaning cloth) moistened with a small amount of alcohol to completely remove the small dust particles.

NOTICE

Never wipe the optical filter hard. The filter may become scratched, which can cause errors.

Cleaning of Equipment

Remove dirt on equipment by gently wiping with a soft cloth.

Inspection

Inspection points	Details	Tools required
Power supply	The voltage measured at the power supply terminal block must be within the rated voltage range, 24 V DC (21.6 to 26.4 V DC).	Circuit tester
Ambient temperature	The operating ambient temperature inside the cabinet must be between 0 and 50°C.	Thermometer
Ambient humidity	The operating ambient humidity inside the cabinet must be between 35% and 85%.	Hygrometer
Installation condition	Cables and connectors connected to each device must be correctly inserted and locked.	Screwdriver

Specifications and Dimensions

Sensor
Z550-SW70

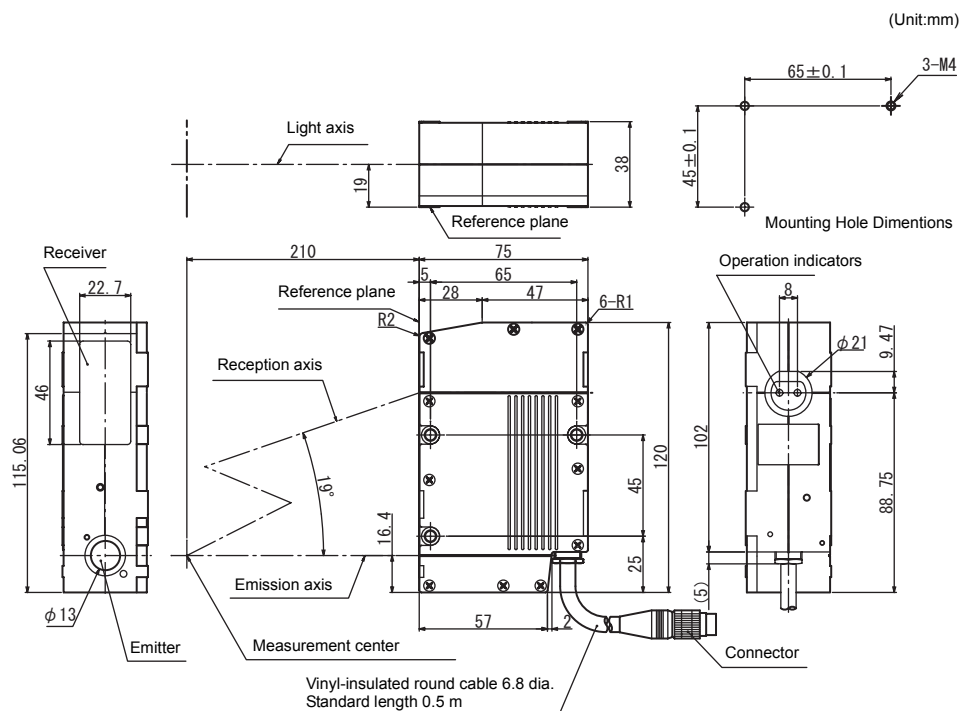

Sensor Installation		Diffuse reflection only
Reference distance (direction of height)		210mm (for 60-mm measurement range mode)
Measure-ment range	Direction of width	70mm (at 200 mm-reference distance)
	Direction of height *1	±30 mm max. (for 60-mm measurement range mode)
Light source		Visible semiconductor laser (wave length: 658 nm, 15 mW max, class 3B)
Beam dimensions *2		120 μ m x 75 mm typical at the 200 mm-reference distance
Resolution in the direction of width *3		0.1 mm
Resolution in the direction of height *4		10 μ m
Linearity in the direction of height *5		±0.5% F.S.
LED indicator lamp		Lit when the laser is on
Temperature characteristic *6		0.1% F.S./°C

Operation environment robustness	Degree of protection	IP66
	Ambient operating illumination	Illumination at light-receiving surface: 3,000 lx max., incandescent light
	Ambient temperature	0 to +50°C at operation, -15 to +60°C at storage (no freezing)
	Ambient humidity	Operating and storage: 35% to 85% (no condensation)
	Vibration (durability)	10 to 150 Hz (at a double amplitude of 0.35 mm) for 8 minutes each in the X, Y, and Z directions
Materials	Body: Aluminum die-cast Cable sheathing: Heat-resistant PVC Connector: Zinc alloy and brass	
Cable length	0.5m	
Minimum bending radius	68mm	
Weight	Approx. 550g	
Accessory	CLASS 3B Warning label (IEC60825-1: 1993 +A1: 1997) × 2	

*1 For 60-mm measurement range mode



Other range mode p.25

*2 Defined as $1/e^2$ (13.5%) of the central light intensity. Leakage of light is also present in areas other than those defined. Thus, there are some influences in cases where the reflection factor of the area surrounding the workpiece is higher than that of the workpiece itself.

*3 When an OMRON-standard workpiece (alumina ceramics) is placed at 200-mm distance, and edge position is measured. 60-mm measurement range mode is used. The average of 16 measurements is taken. Note that the resolution performance may not be satisfied in the presence of strong magnetic fields.

*4 When an OMRON-standard workpiece (alumina ceramics) is placed at 200-mm distance, and its average height of all lines is measured. The average of 16 measurements is taken. Note that the resolution performance may not be satisfied in the presence of strong magnetic fields.

*5 The error in relation to the ideal straight line when the average height of all lines on an OMRON-standard workpiece (alumina ceramics) is measured. The degree of linearity may change depending on the workpiece.

60-mm Range Mode

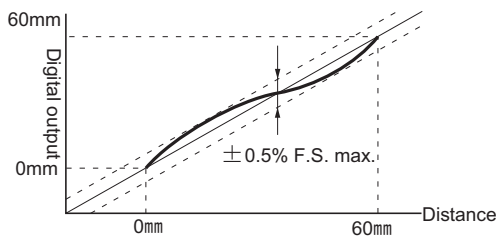

*6 The value obtained at measurement with the space between the sensor and the workpiece fixed with an aluminum jig. The measurement range is 60 mm.

Controller
Z5FP-MC10

(Unit: mm)

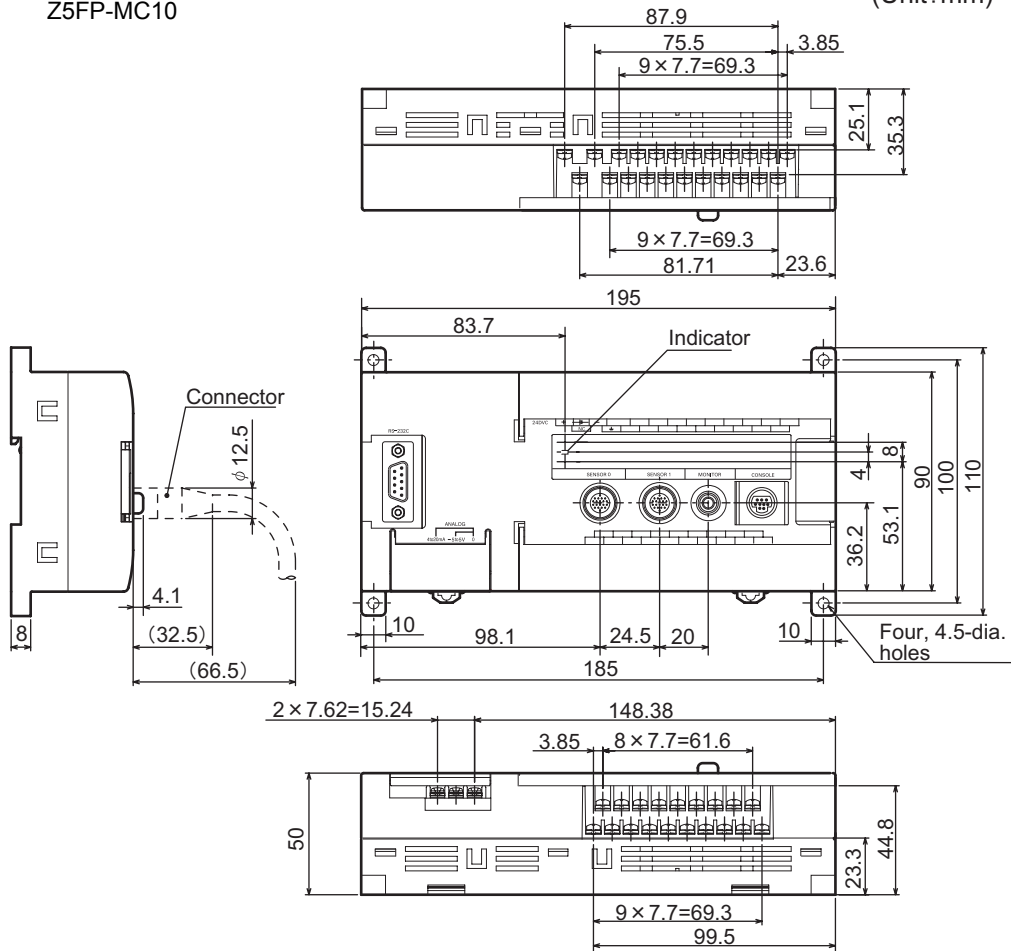

General specifications

Power supply voltage	21.6 to 26.4 V DC
Current consumption	1 A max. (with 2 sensors connected) *1
Insulation resistance	Between the group of external DC terminals and the ground terminal: 20 MΩ max. (at 100 V DC mega) (when the built-in surge absorber is removed)
Dielectric strength	Between the group of external DC terminals and the ground terminal: 1000 V AC at 50/60 Hz (when the built-in surge absorber is removed)
Leakage current	10 mA max.
Noise resistance	1500 Vp-p; Pulse width: 0.1 μs/1 μs; Rising edge: 1-ns pulse
Vibration resistance	10 to 150 Hz (at a double amplitude of 0.1 mm) for 8 minutes each in the X, Y, and Z directions
Shock resistance	200m/s ² ; 3 times each in 6 directions
Ambient temperature	0 to +50°C at operation, -15 to +60°C at storage (no freezing and condensation)
Ambient humidity	Operating and storage: 35% to 85% (no condensation)
Ambient environment	No corrosive gases
Ground	D-type ground (ground resistance 100Ω or less) * conventional class 3 ground
Degree of protection	IEC60529 IP20 (in-panel)

General specifications

Materials	Console: ABS
Weight	Approx. 0.7kg

Performance specifications

Number of connectable sensors	Up to two Z550-SW70 sensors can be connected.
Number of scenes	16
Averaging number	9 levels (1 to 256 times)
Sensor control	6 levels (varies depending on the sensor)
Area specification function	Available
Control of quantity of light	Multi-sensitivity adjustment (dynamic range or sampling interval takes precedence) fixed sensitivity, automatic sensitivity adjustment
Measurement time *2	100 ms (at fixed sensitivity) 120 ms (at automatic sensitivity) 100 ms to 250 ms (when sampling interval takes precedence) 100 ms to 629 ms (when dynamic range takes precedence)
Run Mode	Continuous measurement or trigger measurement
Image preprocessing	Noise removal
Measurement pre-processing	Interpolation processing, filter processing Inclination compensation processing Height and position compensation processing
Detection method	Height position method Reflectance method
Measurement item	Height, Step: 2 pts, Step: 3 pts, Edge position, Width, Edge center, Peak/Bottom, Cross-sectional area, Inclination, Roughness, User-defined
Logging function	The measurement results of up to 3000 measurements can be stored. (It is possible to select after how many measurements their measurement results are stored.)
Output pre-processing	Forced zero, Offset/span adjustment
Profile data output	Up to 1024 height profiles can be output in one batch. The output format may be either ASCII code or binary format (when sending via XMODEM)
Results output	Terminal block: Judgment result Analog: Measurement result RS-232C: Measurement result, judgment result, profile data
Screen Displays	Image monitor, Trend monitor, Digital monitor, Profile monitor
Tool function	Peripheral image display function, test measurement function
Terminal blocks	11 input points: TRIGGER, LD-OFF, RESET, DI0 to DI7 21 output points: DO0 to DO19 and GATE
RS-232C (Baud rate)	Up to 115 kbps (at XMODEM transmission, external trigger measurement) Normally 38.4 kbps
Monitor interface	1 channel (for pin jack or overscan monitor)
Analog output resolution	The full output scale can be divided into a maximum of 40,000 divisions. Resolution (*3): 0.25 mV (± 5 V), 0.4 μ A (4 to 20 μ A)

*1 Average current at normal operation after power is ON.

*2 The sampling interval varies depending on the measurement settings. Check the actual sampling interval on the image monitor.

*3 When performing measurement taking the average of every 64 measurements with an OMRON K3AS linear sensor controller connected.

Console
Z300-KP

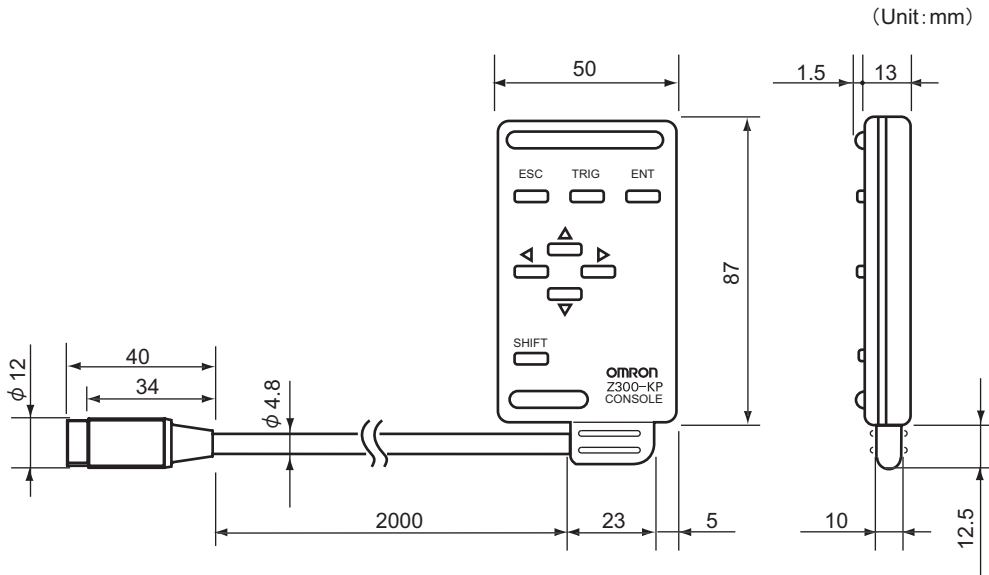

General specifications

Vibration resistance	10 to 150 Hz at a single-amplitude of 0.15 mm, 4 times for 8 minutes each in 3 directions
Shock resistance	196m/s ² ; 3 times each in 6 directions
Ambient temperature	0 to +50°C at operation, -25 to +65°C at storage (no freezing and condensation)
Ambient humidity	Operating and storage: 35% to 85% (no condensation)
Ambient environment	No corrosive gases
Degree of protection	IEC60529 IP20 (in-panel)
Minimum bending radius	75mm
Materials	Console: ABS Cable sheathing: Heat-resistant chlorinated vinyl Connector: PC and PBT
Weight	Approx. 135g

Sensor Extension Cable
Z519-SC1R

(Unit:mm)

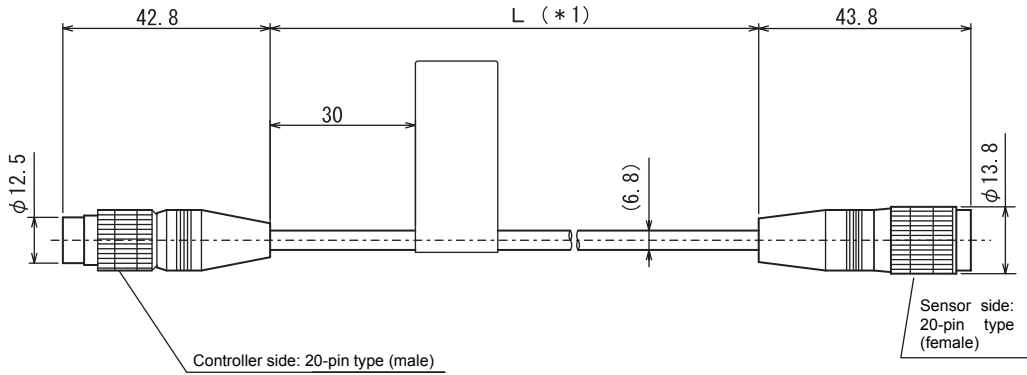

*1 Length of Cable

L(mm)
3000 ⁺⁵⁰ / ₀
6000 ⁺¹⁵⁰ / ₀
8000 ⁺³⁰⁰ / ₀
13000 ⁺⁴⁵⁰ / ₀

General specifications

Ambient temperature	0 to +50°C at operation, -15 to +60°C at storage (no freezing and condensation)
Ambient humidity	Operating and storage: 35% to 85% (no condensation)
Vibration resistance	10 to 150 Hz (at a double amplitude of 0.35 mm) for 8minutes each in the X, Y, and Z directions
Materials	Cable sheathing: Heat-resistant chlorinated vinyl Connector: Zinc alloy and brass
Minimum bending radius	68 mm

Monitor Cable
F150-VM

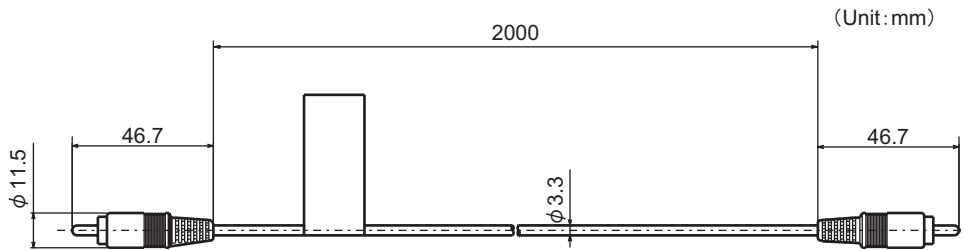

General specifications

Vibration resistance	10 to 150 Hz at a single-amplitude of 0.15 mm, 4 times for 8 minutes each in 3 directions
Shock resistance	196m/s ² ; 3 times each in 6 directions
Ambient temperature	0 to +50°C at operation, -25 to +65°C at storage (no freezing and condensation)
Ambient humidity	Operating and storage: 35% to 85% (no condensation)
Ambient environment	No corrosive gases
Degree of protection	IEC60529 IP20 (in-panel)
Minimum bending radius	50 mm
Materials	Cable sheathing: Super heat-resistant chlorinated vinyl Connector: PVC
Weight	Approx. 40g
Accessories	BNC jack adapter

Color Liquid Crystal Display Monitor
F150-M05L

(Unit: mm)

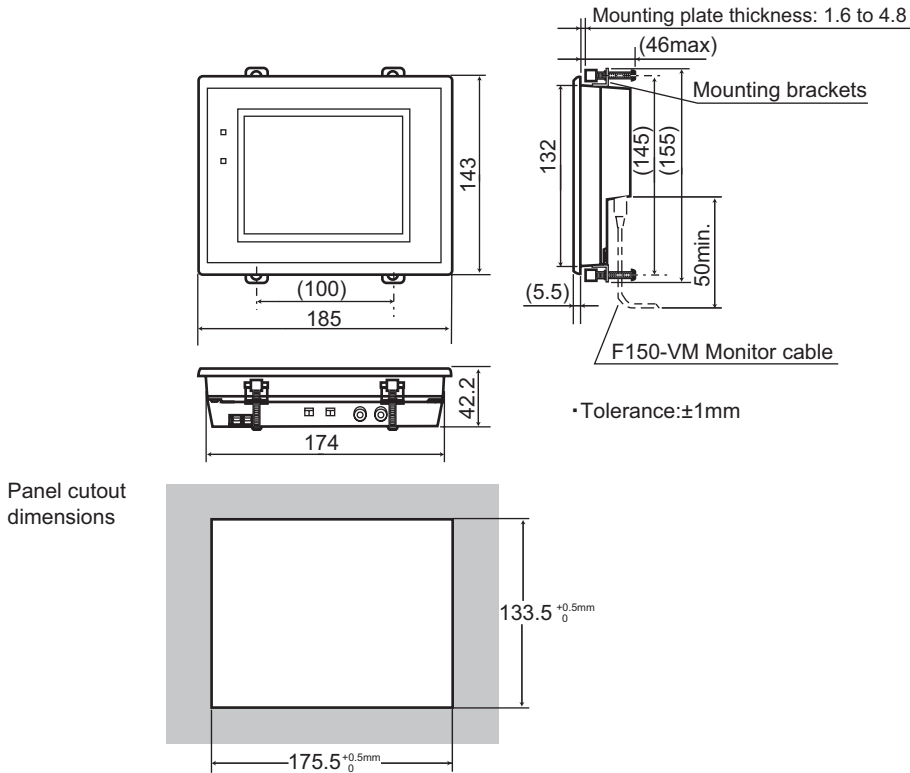

General specifications

Power supply voltage	20.4 to 26.4 V DC
Current consumption	700 mA max.
Vibration resistance	10 to 150 Hz at a single-amplitude of 0.1 mm (maximum acceleration: 15 m/s ²), 10 times for 8 minutes each in 3 directions
Shock resistance	150 m/s ² ; 3 times each in 6 directions
Ambient temperature	0 to +50°C at operation, -25 to +65°C at storage (no freezing and condensation)
Ambient humidity	Operating and storage: 35% to 85% (no condensation)
Ambient environment	No corrosive gases
Degree of protection	IEC60529 IP20
Materials	Case: ABS/PC Display surface: PMMA (acrylic)
Weight	Approx. 610kg
Accessories	4 mounting brackets

Performance specifications

Panel size	5.5 inches (111.36 (H) x 123 (V) mm)
Panel type	TFT color liquid crystal display
Resolution	320 x 240 dots

Performance specifications

Image pitch	0.348 (H) x 0.348 (V) mm
Contrast	85:1 (typical)
Viewable angle	25° up/down and 50° left/right (with a contrast ratio > 10)
Luminance	250 cd/m ² (typical)
Backlight	Cold cathode fluorescent light
Response speed	60 ms max.
Input signal	NTSC composite video (1.0 V/75 Ω termination)

Video Monitor (Monochrome)
F150-M09

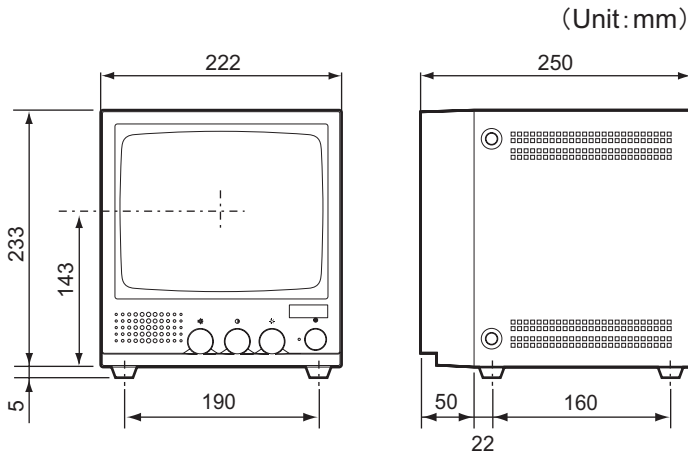

General specifications

Power supply voltage	85 to 264 V AC, 50/60 Hz
Power consumption	20 W max.
Vibration resistance	5 to 100 Hz in 3 directions, 10 minutes x 6 for each sweep At a double-amplitude of 0.16 mm or an acceleration of 7.35 m/s ² (whichever is smaller)
Ambient temperature	-10 to +50°C at operation, -20 to +65°C at storage (no freezing and condensation)
Ambient humidity	Operating and storage: 10 % to 90 % (no condensation)
Ambient environment	No corrosive gases
Materials	Front: ABS plastic Metal part: SECC (galvanized steel sheet)
Weight	Approx. 4.5 kg

Performance specifications

CRT size	9 inches (164 (H) x 123 (V) mm)
CRT type	CRT monochrome (medium persistence)
Resolution	800 TV lines min. (at center)
System	Number of scanning lines: 600 Horizontal frequency: 15.75 kHz Field frequency: 60 Hz
I/O impedance	75 Ω, high impedance (selectable)
I/O level and polarity	Composite image signal: 1 V (peak to peak) Image: 0.7 V (peak to peak), positive Synchronization: 0.3 V (peak to peak), negative
Input signal	NTSC composite video (1.0 V/75 Ω termination)

Laser Product Classifications

EN/JIS

Class	Description
Class 1	Safe inherently by engineering design.
Class 2	Low power in the visible spectrum (wavelength: 400 to 710 nm); eye protection normally afforded by aversion responses.
Class 3A	Direct intrabeam viewing with optical aids may be hazardous. Power of less than 5 mW max. for visible spectrum. Less than five times the output of the Class 1 for wavelengths other than the visible spectrum.
Class 3B	Direct intrabeam viewing may be hazardous. It is not hazardous to view the pulse laser radiation that does not focus due to scattered reflection and the power that allows safe viewing under certain conditions is less than 0.5 W.
Class 4	High power; diffused reflection may be hazardous and may lead to skin hazards or fire.

FDA/ANSI

Class	FDA definition	ANSI description
Class I/1	Limits applicable to devices that have emissions in the ultraviolet, visible, and infrared spectra, and limits below which biological hazards have not been established.	A Class 1 laser is considered to be incapable of producing damaging radiation levels during operation and maintenance and is, therefore, exempt from any control measures or other forms of surveillance.
Class IIa/2a	Limits applicable to products whose visible emission does not exceed Class I limits for emission durations of 1,000 seconds or less and are not intended for viewing.	Class 2 lasers are divided into two sub-classes, 2 and 2a. A Class 2 laser emits in the visible portion of the spectrum (0.4 to 0.7 μm) and eye protection is normally afforded by the aversion response including the blink reflex.
Class II/2	Limits applicable to products that have emissions in the visible spectrum (400 to 710 nm) for emission durations in excess of 0.25 second, providing that emissions for other durations and/or wavelengths do not exceed the Class I limits. Class II products are considered hazardous for direct long-term ocular exposure.	
Class IIIa/3a	Limits to products that have emissions in the visible spectrum and that have beams where the total collectable radiant power does not exceed 5 milliwatts.	Class 3 lasers are divided into two sub-classes, 3a and 3b. A Class 3 laser may be hazardous under direct and specular reflection viewing conditions, but the diffuse reflection is usually not a hazard.
Class IIIb/3b	Limits applicable to devices that emit in the ultraviolet, visible, and infrared spectra. Class IIIb products include laser systems ranging from 5 to 500 milliwatts in the visible spectrum. Class IIIb emission levels are ocular hazards for direct exposure throughout the range of the Class, and skin hazards at the higher levels of the Class.	

Class	FDA definition	ANSI description
Class IV/4	Exceeding the limits of Class IIIb and are a hazard for scattered reflection as well as for direct exposure.	A Class 4 laser is a hazard to the eye or skin from the direct beam and sometimes from a diffuse reflection and also can be fire hazard. Class 4 lasers may also produce laser-generated air contaminants and hazardous plasma radiation.

Requirements from Regulations and Standards

Manufacturer's Requirements

EN60825 (IEC60825) "Radiation Safety of Laser Products, Equipment Classification, Requirements and User's Guide"

Requirements; Sub-clause	Classification				
	Class 1	Class 2	Class 3A	Class 3B	Class 4
Description of hazard class	Safe inherently by engineering design	Low power; eye protection normally afforded by aversion responses	Same as Class 2. Direct intrabeam viewing with optical aids may be hazardous	Direct intrabeam viewing may be hazardous	High power; diffused reflection may be hazardous
Protective housing	Required for each laser product; limits access necessary for performance of functions of the products				
Safety interlock in protective housing	Designed to prevent removal of the panel until accessible emission values are below the AEL for the class assigned				
Remote control	Not required			Permits easy addition of external interlock in laser installation	
Key control	Not required			Laser inoperative when key is removed	
Emission warning device	Not required			Give audible or visible warning when laser is switched on or if capacitor bank of pulsed laser is being charged	
Attenuator	Not required			Give means beside ON/OFF switch to temporarily block beam	
Location controls	Not required		Controls located so adjustment does not require exposure to AEL above class 1 or 2		
Viewing optics	Emission from all viewing systems must be below Class 1 AEL's as applicable				
Scanning	Scan failure shall not cause product to exceed its classification				
Class label	Required wording	Warning and explanatory labels and specified wording (Refer to page 6)			
Aperture label	Not required			Specified wording required	
Service entry label	Required as appropriate to the class of accessible radiation				
Override interlock label	Required under certain conditions as appropriate to the class of laser used				
User information	Operation manuals must contain instructions for safe use				
Purchasing and service information	Promotion brochures must reproduce classification labels; service manuals must contain safety information				
Medical products	Special calibration instructions required			Special calibration instructions, means for measurement and target-indicator required	
Fibre optic	Cable service connections require tool to disconnect if disconnection breaks protective housing and permits access above Class 1				

With respect to the requirements of remote interlock connector, key control, emission warning and attenuator, Class 3B laser products not exceeding five times the AEL of Class 2 in the wavelength range of 400 to 700 nm are to be treated as Class 3A laser products.

Note: This table is intended to provide a convenient summary of requirements. See text of standard for complete requirements.

JIS C6802 "Radiation Safety Standards for Laser Products"

Requirements; Sub-clause	Classification				
	Class 1	Class 2	Class 3A	Class 3B	Class 4
Description of hazard class	Safe inherently by engineering design	Low power; eye protection normally afforded by aversion responses	Same as Class 2. Direct intra-beam viewing with optical aids may be hazardous	Direct intrabeam viewing may be hazardous	High power; dif-fused reflection may be hazardous
Protective housing	Required for each laser product; limits access necessary for performance of functions of the products				
Safety interlock in protective housing	Designed to prevent removal of the panel until accessible emission values are below the AEL for the class assigned				
Remote control	Not required			Permits easy addition of external interlock in laser installation	
Key control	Not required			Laser inoperative when key is removed	
Emission warning device	Not required			Give audible or visible warning when laser is switched on or if capacitor bank of pulsed laser is being charged	
Attenuator	Not required			Give means beside On/Off switch to temporarily block beam	
Location controls	Not required		Controls located so adjustment does not require exposure to AEL above class 1 or 2		
Viewing optics	Emission from all viewing systems must be below Class 1 AEL's as applicable				
Scanning	Scan failure shall not cause product to exceed its classification				
Class label	Required wording	Warning and explanatory labels and specified wording (Refer to page 6)			
Aperture label	Not required			Specified wording required	
Service entry label	Required as appropriate to the class of accessible radiation				
Override interlock label	Required under certain conditions as appropriate to the class of laser used				
User information	Operation manuals must contain instructions for safe use				
Purchasing and service information	Promotion brochures must reproduce classification labels; service manuals must contain safety information				
Additional requirements for laser optical fibre transmission system	Cable service connections require tool to disconnect if disconnection breaks protective housing and permits access above Class 1				

With respect to the requirements of remote interlock connector, key control, emission warning and attenuator, Class 3B laser products not exceeding five times the AEL of Class 2 in the wavelength range of 400 to 700 nm are to be treated as Class 3A laser products.

Note: This table is intended to provide a convenient summary of requirements. See text of standard for complete requirements.

FDA (21 CFR1040.10 "Laser Products")

Requirements	Class (see note 1)					
	I	Ila	II	IIla	IIlb	IV
Performance (all laser products)						
Protective housing	R (see note 2)	R (see note 2)	R (see note 2)	R (see note 2)	R (see note 2)	R (see note 2)
Safety interlock	R (see notes 3,4)	R (see notes 3,4)	R (see notes 3,4)	R (see notes 3,4)	R (see notes 3,4)	R (see notes 3,4)
Location of controls	N/A	R	R		R	R
Viewing optics	R	R	R	R	R	R
Scanning safeguard	R	R	R	R	R	R
Performance (laser systems)						
Remote control connector	N/A	N/A	N/A	N/A	R	R
Key control	N/A	N/A	N/A	N/A	R	R
Emission indicator	N/A	N/A	R	R	R (see note 10)	R (see note 10)
Beam attenuator	N/A	N/A	R	R	R	R
Reset	N/A	N/A	N/A	N/A	N/A	R (see note 13)
Performance (specific purpose products)						
Medical	S	S	S	S (see note 8)	S (see note 8)	S (see note 8)
Surveying, leveling, alignment	S	S	S	S	NP	NP
Demonstration	S	S	S	S	S (see note 11)	(see note 11)
Labeling (all laser products)						
Certification & identification	R	R	R	R	R	R
Protective housing	D (see note 5)	D (see note 5)	D (see note 5)	D (see note 5)	D (see note 5)	D (see note 5)
Aperture	N/A	N/A	R	R	R	R
Class warning	N/A	R (see note 6)	R (see note 7)	R (see note 9)	R (see note 12)	R (see note 12)
Information (all laser products)						
User information	R	R	R	R	R	R
Product literature	N/A	R	R	R	R	R
Service information	R	R	R	R	R	R

Abbreviations:

R: Required.

N/A: Not applicable.

S: Requirements: Same as for other products of that Class. Also see footnotes.

NP: Not permitted.

D: Depends on level of interior radiation.

Footnotes:

Note 1: Based on highest level accessible during operation.

Note 2: Required wherever & whenever human access to laser radiation above Class I limits is not needed for product to perform its function.

Note 3: Required for protective housings opened during operation or maintenance, if human access thus gained is not always necessary when housing is open.

Note 4: Interlock requirements vary according to Class of internal radiation.

Note 5: Wording depends on level & wavelength of laser radiation within protective housing.

Note 6: Warning statement label.

Note 7: CAUTION logotype.

Note 8: Requires means to measure level of laser radiation intended to irradiate the body.

Note 9: CAUTION if 2.5 mW cm^2 or less, DANGER if greater than 2.5 mW cm^2 .

Note 10: Delay required between indication & emission.

Note 11: Variance required for Class IIb or IV demonstration laser products and light shows.

Note 12: DANGER logotype.

Note 13: Required after August 20, 1986.

User's Requirements

EN60825 (IEC60825)

Requirements; Sub-clause	Classification				
	Class 1	Class 2	Class 3A	Class 3B	Class 4
Remote interlock	Not required			Connect to room or door circuits	
Key control	Not required			Remove key when not in use	
Beam attenuator	Not required			When in use prevents inadvertent exposure	
Emission indicator device	Not required			Indicates laser in energized	
Warning signs	Not required			Follow precautions on warning signs	
Beam path	Not required	Terminate beam at end of useful length			
Specular reflection	No requirements			Prevent unintentional reflections	
Eye protection	No requirements		Required if engineering and administrative procedures not practicable and MPE exceeded		
Protective clothing	No requirements			Sometimes required	Specific requirements
Training	No requirements		Required for all operator and maintenance personnel		

With respect to the requirements of remote interlock connector, key control, beam attenuator, and emission indicator, Class 3B laser products not exceeding five times the AEL of Class 2 in the wavelength range of 400 to 700 nm are to be treated as Class 3A laser products.

Note: This table is intended to provide a convenient summary of requirements. See text of standard for complete precautions.

JIS C6802

Item	Class 1	Class 2	Class 3A	Class 3B		Class 4
				3B*	3B	
Remote interlock	Not required			Connect the remote interlock of the laser beam to the emergency main interlock, the interlock of the room, or the interlock of the door.		
Key control	Not required			Do not keep the key in the lock when the laser beam is not used.		
Beam breaker or attenuator	Not required			Used to protect people from accidental radiation by the laser beam.		
Warning sign	Not required			Post a proper warning sign on the door to the room where laser beam equipment is installed.		
Beam path	Not required	The laser beam must be terminated and, as a rule, must be enclosed. If the laser beam is exposed, the vertical height of the beam must not be the same as that of the eyes.				
Mirror reflection	Not required			Appropriate optical elements must be securely attached and you must be able to control the optical elements during laser radiation.		
Eye protection	Not required			Use eye protectors except in special, specified locations.		
Protection clothes	Not required		Wear protection clothes if exposure of the skin to the laser beam may exceed the MPE of the skin.			
Training	Not required		The laser system must be operated by only properly trained people.			

Note: *Class 3B applies to any laser beam with a power of 5 mW maximum in the visible range of the laser beam.

ANSI Z136.1:1993 "American National Standard for the Safety Use of Lasers"

Control measures	Classification					
	1	2a	2	3a	3b	4
Engineering Controls	X	X	X	X	X	X
Protective Housing	X	X	X	X	X	X
Without Protective Housing	LSO shall establish Alternate Controls					
Interlocks on Protective Housing	☆	☆	☆	☆	X	X
Service Access Panel	☆	☆	☆	☆	X	X
Key Control	---	---	---	---	•	X
Viewing Portals	---	---	MPE	MPE	MPE	MPE
Collecting Optics	MPE	MPE	MPE	MPE	MPE	MPE
Totally Open Beam Path	---	---	---	---	X NHZ	X NHZ
Limited Open Beam Path	---	---	---	---	X NHZ	X NHZ
Enclosed Beam Path	None is required if 4.3.1 and 4.3.2 fulfilled					
Remote Interlock Connector	---	---	---	---	•	X
Beam Stop or Attenuator	---	---	---	---	•	X
Activation Warning Systems	---	---	---	---	•	X
Emission Delay	---	---	---	---	---	X
Indoor Laser Controlled Area	---	---	---	---	X NHZ	X NHZ
Class 3b Laser Controlled Area	---	---	---	---	X	---
Class 4 Laser Controlled Area	---	---	---	---	---	X
Laser Outdoor Controls	---	---	---	---	X NHZ	X NHZ
Laser in Navigable Airspace	---	---	---	•	•	•
Temporary Laser Controlled Area	☆ MPE	☆ MPE	☆ MPE	☆ MPE	---	---
Remote Firing & Monitoring	---	---	---	---	---	•
Labels	X	X	X	X	X	X
Area Posting	---	---	---	•	X NHZ	X NHZ

Note: LEGEND

- X: Shall
- : Should
- : No requirement
- ☆ : Shall if enclosed Class 3b or Class 4
- MPE: Shall if MPE is exceeded
- NHZ: Nominal Hazard Zone analysis required

Revision History

Revision code	Revision date	Revised content
01	February, 2003	First edition
01A	January, 2004	Pages 47 and 48: Note and reference to it added; numbers referencing previous notes incremented.