

DeviceNet Safety System

# NE1A/DST1

*Omron now offers a DeviceNet compatible Safety System, that can be used 3-ways: as a Stand-alone controller, as a Safety network expandable with remote I/O blocks, or combined with DeviceNet to form a combined Network.*

- Conforms to Global Safety Standards
- Individual I/O LED status and error indicators
- USB Programming Port
- IEC 61508 SIL 3
- EN954-1 Category 4
- UL1604 Class 1, Div. 2 Group A,B,C,D



**Product Information**

Introducing a Safety Network System that dramatically alters previous safety design.

Programmable safety circuits are incorporated to facilitate efficient designing and modifications. Moreover, Safety I/O Terminals can be added to increase safety I/O capacity for distributed allocation through the network. DeviceNet wiring on the existing network can be used as is, facilitating efficient design by expanding on the existing system.

The programmability of safety circuits, expandability of I/O using the network, and compatibility with the DeviceNet open network effects major changes to the framework of previous safety design systems.

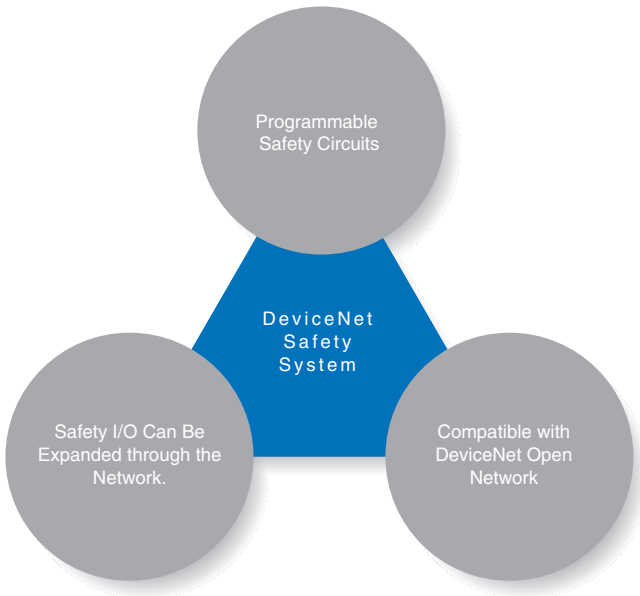

**Complies with the Highest Safety Standards in the world**

The DeviceNet Safety System conforms to IEC 61508 SIL3 for functional safety, and EN 954-1 Category 4 for machine safety, complying with the world's highest level of safety standards.

**IEC 61508 SIL 3**

Safety circuits must be able to function to provide safety at anytime. Conversely, the degree of lack of safety is used as the indicator. In IEC 61508, safety is defined as the Probability of Failure per Hour, or PFH. Based on this, the SIL (Safety Level) is classified into four levels. SIL 3 indicates a probability of dangerous failure of once in 1,000 years, which is the highest level in machine safety.

**EN 954-1 Safety Category 4**

EN standards evaluate the level of machine risk and require the incorporation of risk minimization measures. In EN 954-1, five safety categories have been established, with Safety Category 4 indicating designs that require the highest safety design level. This category is demanded for machines with the highest level of danger, wherein "serious injury (severed limbs, death, etc.) will occur frequently, with little chance of escaping danger." This category demands that a single fault (failure) in any part of the machine, or a series of faults, will not lead to loss of the machine's safety functions.

**NE1A-SCPU01 Safety Network Controller**

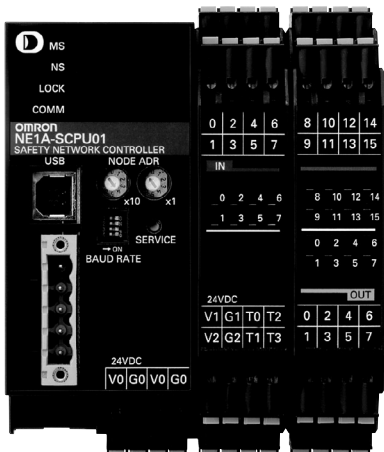

**Programmable Safety Control**

- Incorporates 16 safety inputs and 8 safety outputs. Functions as a compact safety PLC even without using a network.
- Construct safety circuits easily with special Function Blocks.
- Up to 128 Function Blocks can be used.

**DeviceNet Safety Communications Functions**

- Provides DeviceNet Safety Master functionality. Connect up to 16 Safety Slaves. Expand using up to sixteen Input Slaves with 12 points each (192 points total) and eight I/O Slaves with 16 points each (128 points total).
- Safety Slave functionality is also included. Interlock control can be incorporated between Safety Network Controllers.

**DeviceNet Slave Functionality**

- Monitor safety I/O and status information from the DeviceNet Master.

**DST1-series Safety I/O Terminals**



**Safety Input and Safety I/O Models Available**

- Safety inputs: 12-point model (DST1-ID12SL-1)
- Safety I/O: 8-point/8-point model (DST1-MD16SL-1)
- Safety I/O: 4-point/4-point (relay outputs) model (DST1-MRD08SL-1)

**DeviceNet Slave Functionality**

- Safety I/O and status information can be allocated as a DeviceNet Slave.
- Maintenance functions are provided for measuring the number of operations or the operating time for safety devices.

**Easy Wiring**

- Superior construction and preventive maintenance using clamp connectors.

**WS02-CFSC1-E Safety Network Configurator**

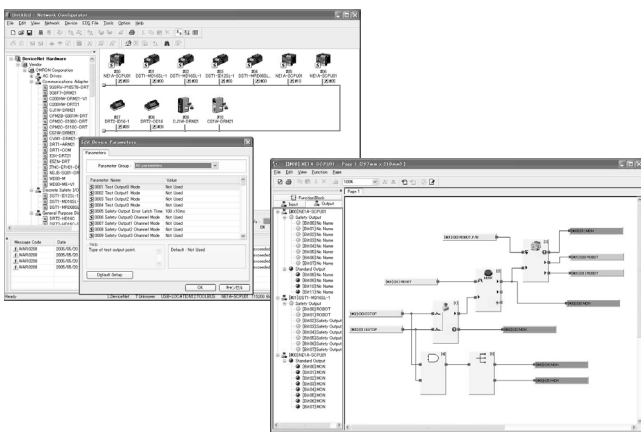

**Network Configurator Functions**

- Includes previous DeviceNet Configurator functions.
- Performs setup for the DeviceNet Safety network configuration.

**Programming Functions**

- I/O configuration functions for Safety Network Controllers and Safety I/O Terminals.
- Programming functions for safety circuits.
- Monitor programs.

## Stand-Alone Programmable Controller

### Programmable Safety Circuits

Until now, safety design involved combining safety relays to configure safety control circuits. This process involved tedious wiring, and moreover, any changes required direct modification of the wiring. The DeviceNet Safety System uses programmable safety circuits, dramatically improving the ease of design and modification.

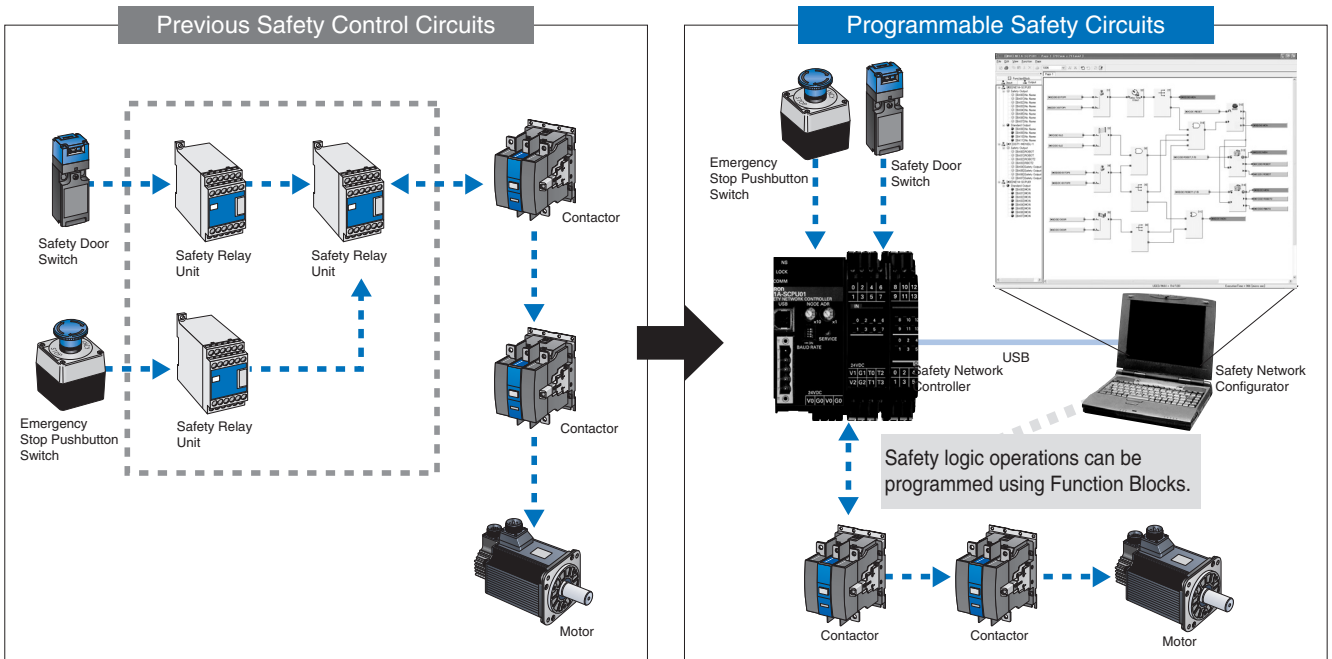

### System Configuration 1

Configuration Example for High-speed Safety I/O Response Using Small Number of Points

- NE1A-SCPU01
- WS02-CFSC1-E

Delivers high-speed I/O response in a single Unit with up to 16 safety inputs and 8 safety outputs.

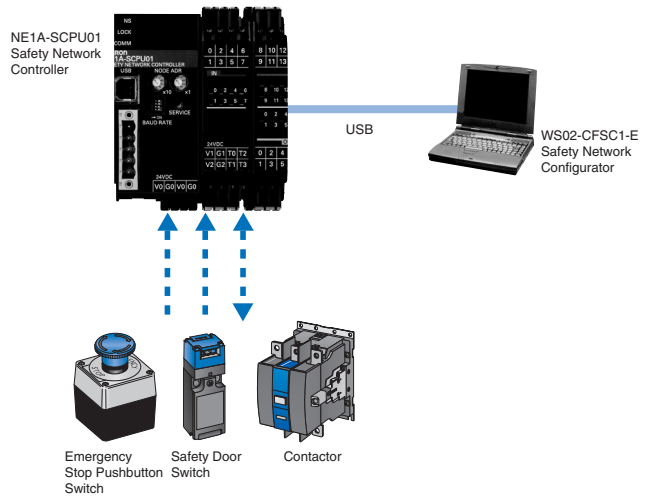

## Safety Network

### Expand Safety I/O Through Networks

Safety components distributed over many different installation locations required long and complicated wiring.  
Replacing the wiring with a network between safety components greatly improves productivity

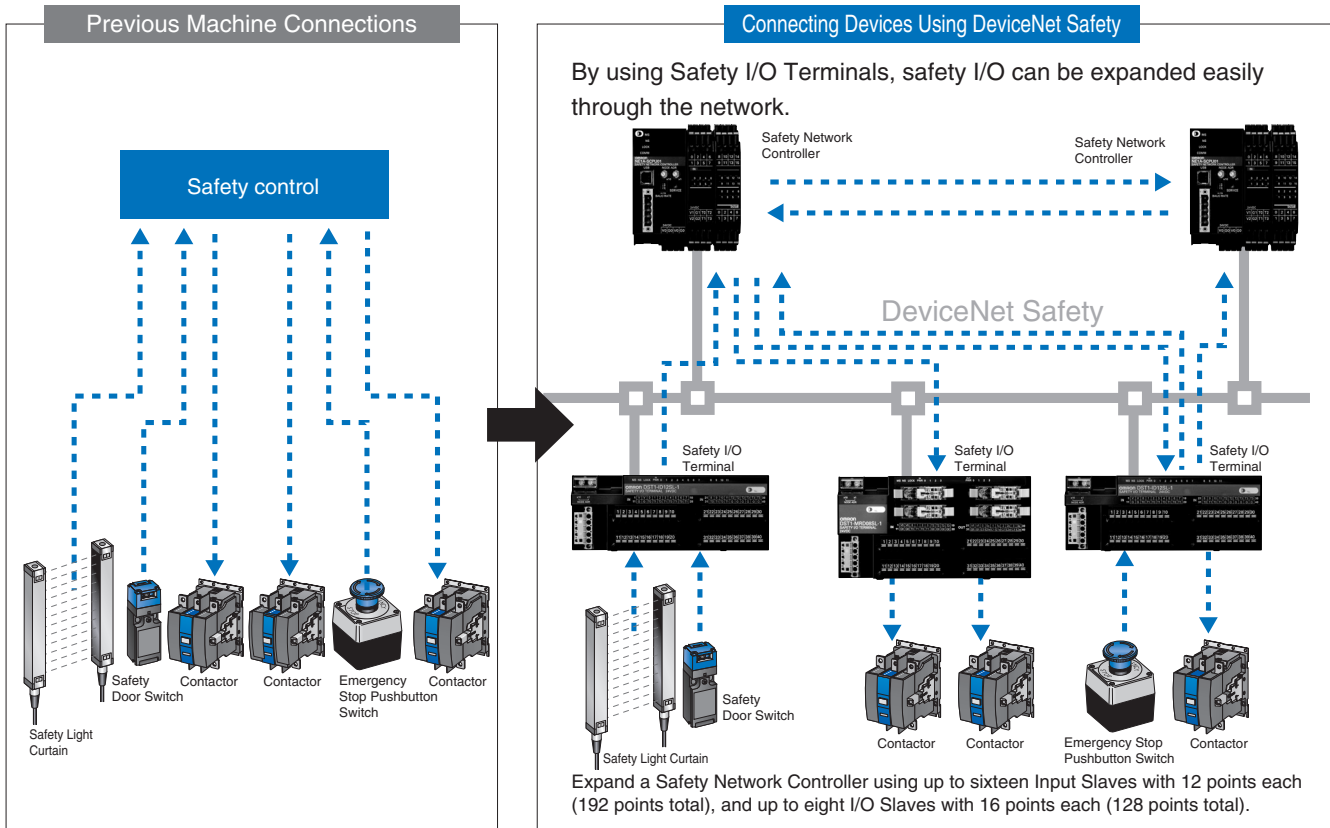

### System Configuration 2

Example of Safety I/O Configuration for Distributed Hazard Sources

- NE1A-SCPU01
- DST1 Series
- WS02-CFSC1-E

Distributed allocation of safety I/O devices can be achieved easily using Safety I/O Terminals and the DeviceNet Safety Network.

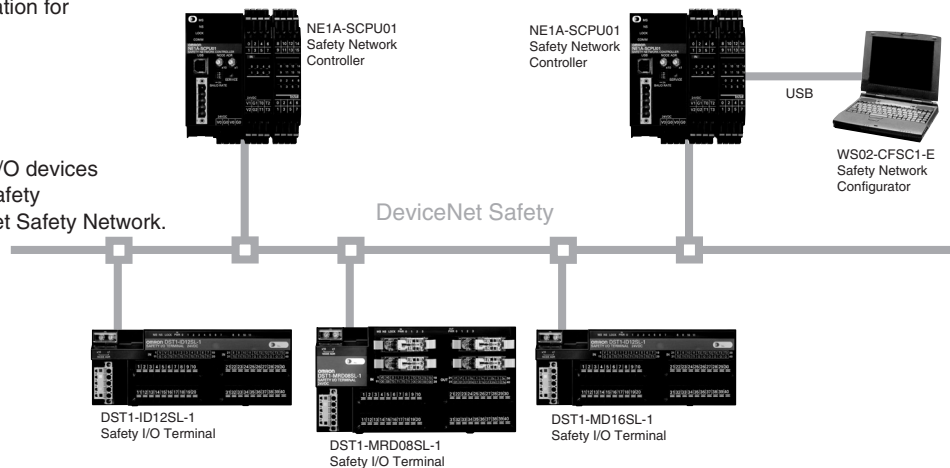

## Combined Safety / DeviceNet Network

### Compatible with the DeviceNet Open Network

Linking machine control is indispensable for achieving total control. By linking to machine control data, safety control can be monitored from the PLC, enabling the location of an error to be identified in an instant and improving maintenance. DeviceNet Safety System utilizes the DeviceNet wiring from the existing network as is.

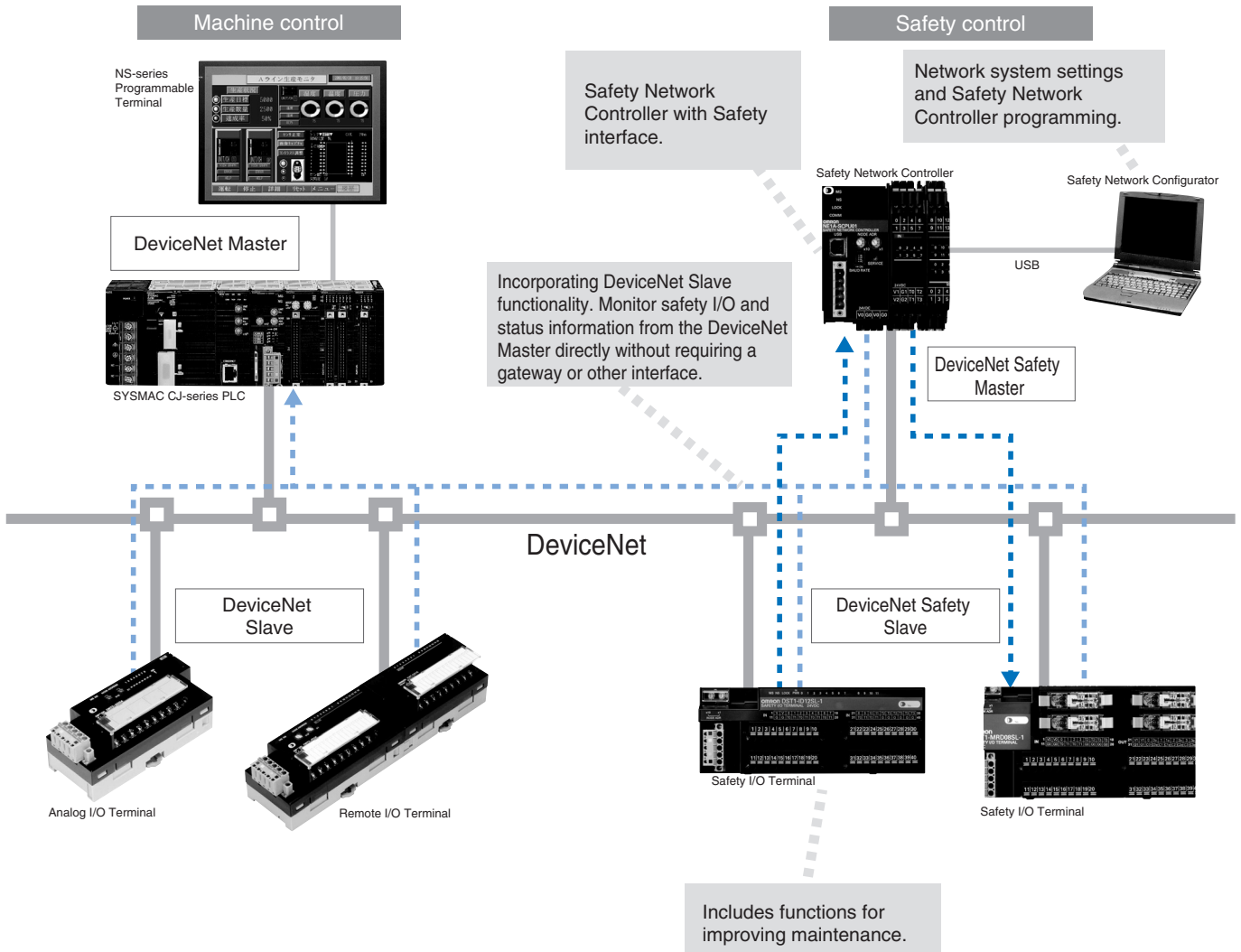

### System Configuration 3

System Configuration Example for Total Control of Machine Control and Safety Control

- SYSMAC CJ Series
- NE1A-SCPU01
- DST1 Series
- WS02-CFSC1-E

The DeviceNet Network can be used to monitor the status of safety I/O and safety circuits on the DeviceNet Safety Network from existing DeviceNet Masters or other PLCs.

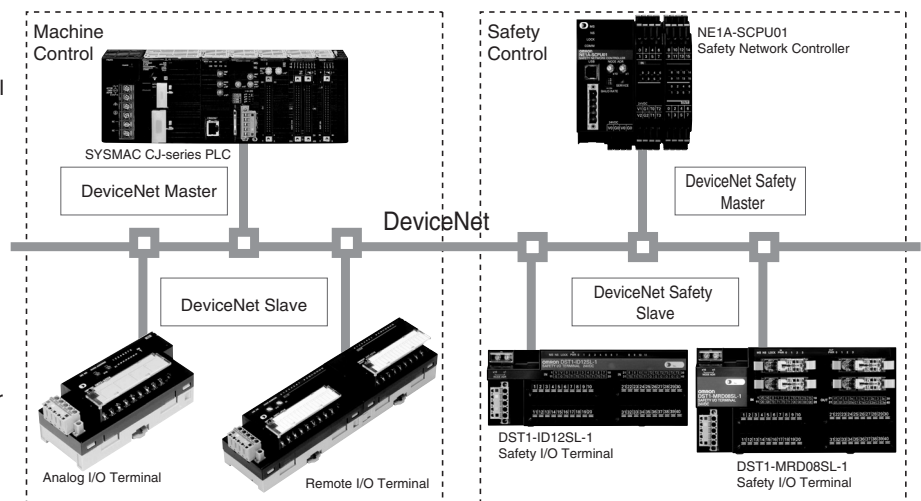



## Ordering Information

### Safety I/O Terminals

Appearance	Appearance Description	Part Number
<p>Safety Network Controller</p> 	<p>16 PNP Inputs 8 PNP Outputs 4 Test Outputs 128 Function Block Programming Removable Cage Clamp Terminals</p>	<p>NE1A-SCPU01</p>

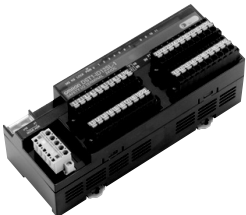
### IP20 Safety I/O Terminals

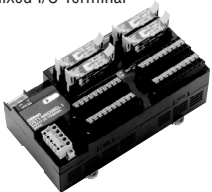
Appearance	Appearance Description	Part Number
<p>Input Terminal</p> 	<p>12 PNP Inputs 4 Test Outputs Removable Cage Clamp Terminals</p>	<p>DST1-ID12SL-1</p>
<p>Mixed I/O Terminal</p> 	<p>8 PNP Inputs 8 PNP Outputs 4 Test Outputs Removable Cage Clamp Terminals</p>	<p>DST1-MD16SL-1</p>
<p>Mixed I/O Terminal</p> 	<p>4 PNP Inputs 4 relay Outputs (4 x 2-single pole) 4 Test Outputs Removable Cage Clamp Terminals</p>	<p>DST1-MRD08SL-1</p>

### Software

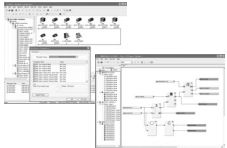
Appearance	Appearance Description	Part Number
<p>Safety Network Configurator</p> 	<p>Installation Disk (CD-ROM) IBM PC/AT Compatible Windows 2000 or XP</p>	<p>WS02-CFSC1-E (English Version)</p>

## Specifications

### NE1A-SCPU01

#### General Specifications

DeviceNet communications power supply voltage	11 to 25 VDC (supplied from communications connector)	
Unit power supply voltage	20.4 to 26.4 VDC (24 VDC 15% +10%)	
I/O power supply voltage		
Consumption current	Communications power supply	24 VDC, 15 mA
	Internal circuit power supply	24 VDC, 230 mA
Overvoltage category	II	
Noise immunity	Conforms to IEC 61131-2	
Vibration resistance	10 to 57 Hz: 0.35 mm, 57 to 150 Hz: 50 m/s <sup>2</sup>	
Shock resistance	150 m/s <sup>2</sup> : 11 ms	
Mounting method	35-mm DIN Track	
Ambient operating temperature	10 to 55°C	
Ambient operating humidity	10% to 95% (with no condensation)	
Ambient storage temperature	40 to 70°C	
Degree of protection	IP20	
Weight	460 g max.	

#### Safety Input Specifications

Input type	Sinking inputs (PNP)
ON voltage	11 VDC min. between each input terminal and G1
OFF voltage	5 VDC min. between each input terminal and G1
OFF current	1 mA max.
Input current	4.5 mA

### DST1-□SL-1

#### General Specifications

DeviceNet communications power supply voltage	11 to 25 VDC (supplied from communications connector)	
Unit power supply voltage	20.4 to 26.4 VDC (24 VDC 15% +10%)	
I/O power supply voltage		
Consumption current	Communications power supply	DST1-ID12SL-1/MD16SL-1: 100 mA DST1-MRD08SL-1: 110 mA
	Internal circuit power supply	
Overvoltage category	II	
Noise immunity	Conforms to IEC 61131-2	
Vibration resistance	10 to 57 Hz: 0.35 mm, 57 to 150 Hz: 50 m/s <sup>2</sup>	
Shock resistance	DST1-ID12SL-1/MD16SL-1: 150 m/s <sup>2</sup> 11 ms DST1-MRD08SL-1: 100 m/s <sup>2</sup> 11 ms	
Mounting method	35-mm DIN Track	
Ambient operating temperature	10 to 55°C	
Ambient operating humidity	10% to 95% (with no condensation) DST1-MRD08SL-1: 10% to 85% (with no condensation)	
Ambient storage temperature	40 to 70°C	
Degree of protection	IP20	
Weight	DST1-ID12SL-1/MD16SL-1: 420 g DST1-MRD08SL-1: 600 g	

#### Safety Input Specifications

Input type	Sinking inputs (PNP)
ON voltage	11 VDC min. between each input terminal and G1
OFF voltage	5 VDC min. between each input terminal and G1
OFF current	1 mA max.
Input current	6 mA

Note: For details on operating precautions and other information required to use the product, be sure to read the following operation manual: DeviceNet Safety DST1-series Safety I/O Terminals Operation Manual (Z904)

#### Safety Output Specifications

Output type	Sourcing outputs (PNP)
Rated output current	0.5 A max. per output
Residual voltage	1.2 V max. between each output terminal and V2
Leakage current	0.1 mA max.

#### Test Output Specifications

Output type	Sourcing outputs (PNP)
Rated output current	0.7 A max. per output (See note.)
Residual voltage	1.2 V max. between each output terminal and V1
Leakage current	0.1 mA max.

Note: Total simultaneous ON current: 1.4 A

#### Standards

Certifying body	Standards
TÜV Rheinland	EN954-1:1996, EN60204-1:1997, EN61000-6-2:2001, EN61000-6-4:2001, EN418:1992, IEC61508 part1-7/12.98-05.00, IEC61131-2/02.03, NFPA 79-2002, ANSI RIA15.06-1999, ANSI B11.19-2003
UL	UL1998 (pending), NFPA79 (pending), UL508, CSA22.2 No14, UL1604

Note: For details on operating precautions and other information required to use the product, be sure to read the following operation manual: DeviceNet Safety Network Controller Operation Manual (Z906)

#### Safety Output Specifications

Output type	Sourcing outputs (PNP)
Rated output current	0.5 A max. per output
Residual voltage	1.2 V max. between each output terminal and V2
Leakage current	0.1 mA max.

#### Test Output Specifications

Output type	Sourcing outputs (PNP)
Rated output current	0.7 A max. per point
Residual voltage	1.2 V max. between each output terminal and V1
Leakage current	0.1 mA max.

#### Safety Output Specifications for Relay Outputs

Relays	G7SA-2A2B, EN 50205 Class A
Minimum applicable load	1 mA at 5 VDC
Rated load for a resistive load	240 VAC: 2 A, 30 VDC: 2 A
Rated load for an inductive load	2 A at 240 VAC (cos =0.3), 1 A at 24 VDC
Mechanical life expectancy	5,000,000 operations min. (switching frequency of 7,200 operations/h)
Electrical life expectancy	100,000 operations min. (at rated load and switching frequency of 1,800 operations/h)

#### Standards

Certifying body	Standards
TÜV Rheinland	EN954-1/12.96, EN60204-1/12.97, EN61000-6-2/10.01, EN61000-6-4/10.01, EN418/1992, IEC61508 part1-7/12.98-05.00, IEC61131-2/02.03, NFPA 79-2002, ANSI RIA15.06-1999, ANSI B11.19-2003
UL	UL1998, NFPA79, UL508, CSA22.2 No14, UL1604 (DST1-ID12SL-1 and DST1-MD16SL-1 only)

WS02-CFSC1-E

System Configuration

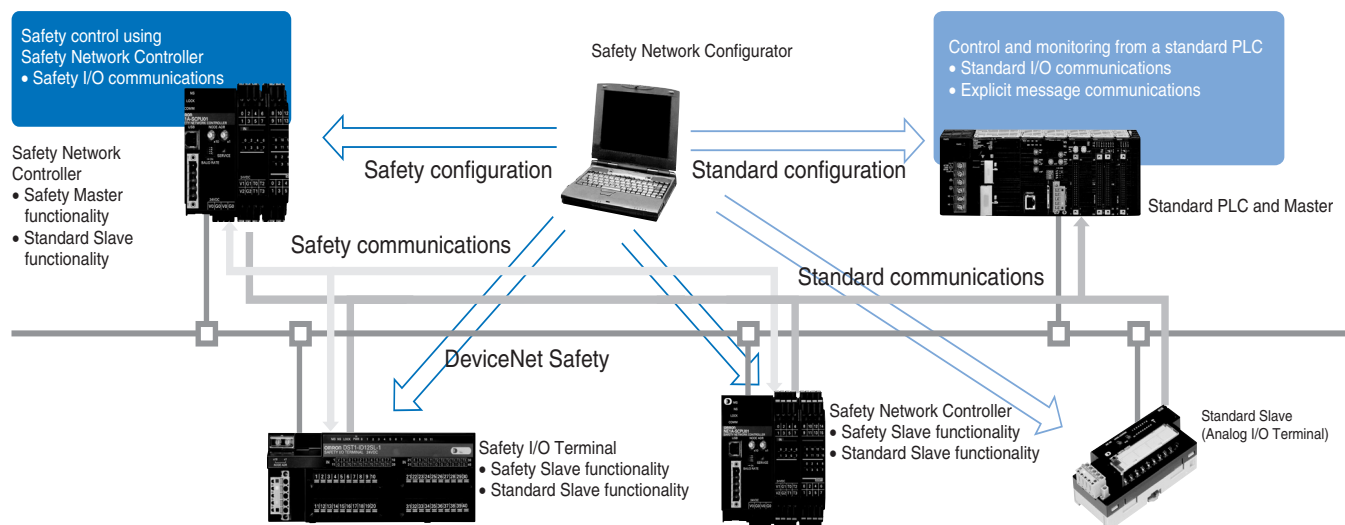

General Specifications

Compatible computer	IBM PC/AT or compatible
CPU	Pentium 300 MHz min.
OS	Windows 2000 or XP
Supported languages	English
Memory	128 Mbytes min.
Hard disk	40 Mbytes min. available space
Monitor	Display functionality of S-VGA monitor or higher
CD-ROM	One CD-ROM drive min.
Communications port	Either of the following communications ports is required. <ul style="list-style-type: none"> <li>• USB port: For online communications via SNC USB port (USB1.1)</li> <li>• DeviceNet Interface Card (3G8E2-DRM21-EV1): For online communications via DeviceNet.</li> </ul>

Manuals

Description	Reference Number
Devicenet Safety Network Controller Operation Manual	Z906
Devicenet Safety DST1-series Safety I/O Terminals Operation Manual	Z904
Devicenet Safety System Configuration Manual	Z905

Note: Windows is a registered trademark of Microsoft.  
 IBM is a registered trademark of International Business Machines Corp.



# Internal Circuit Configuration

NE1A-SCPU01

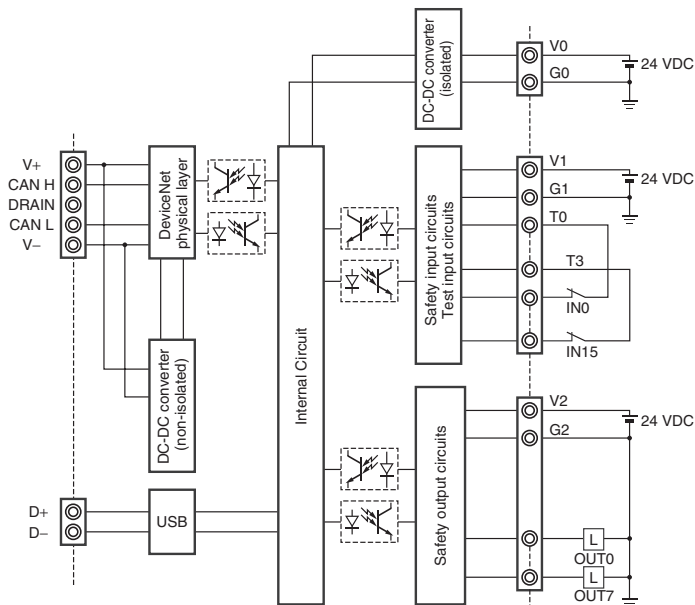

## Safety I/O Terminals

DST1-ID12SL-1

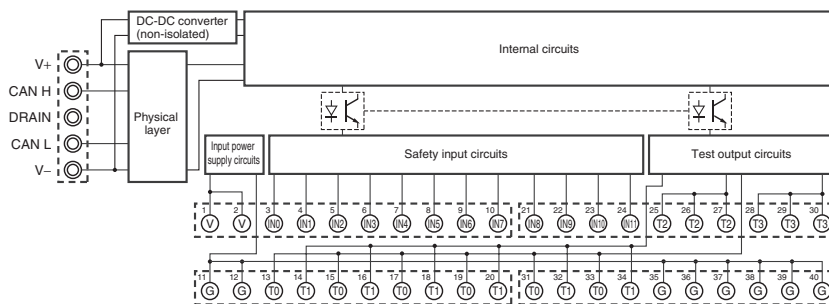

DST1-MD16SL-1

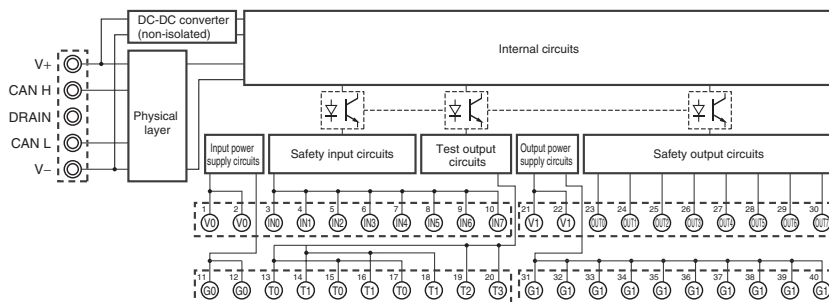

DST1-MRD08SL-1

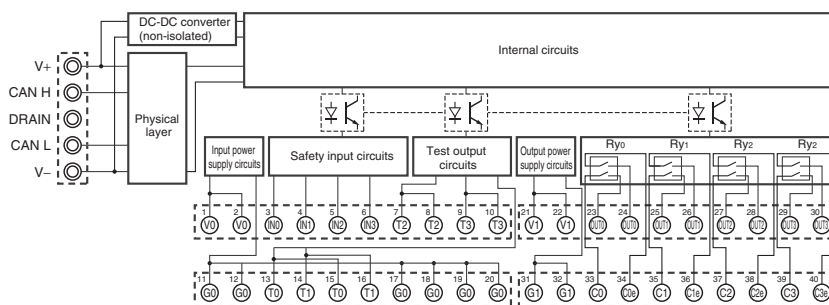

Wiring Diagrams

NE1A-SCPU01

Emergency Stop Applications (Manual Reset)

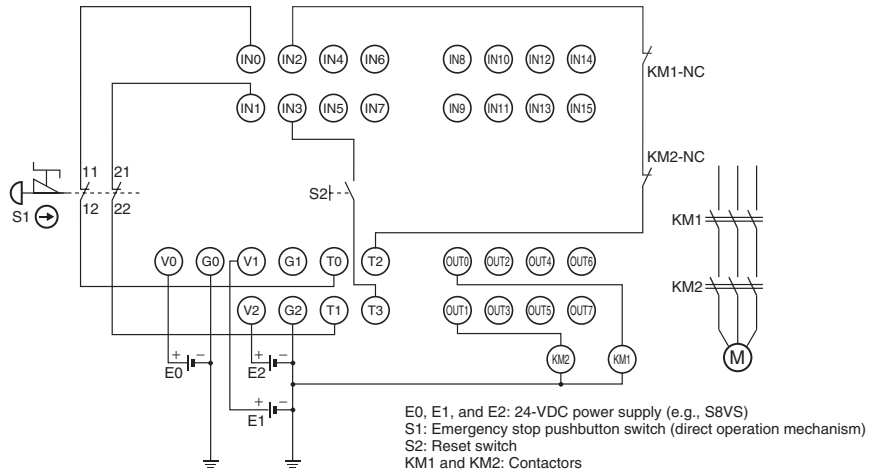

Safety I/O Terminals

● Emergency Stop Switch and Reset

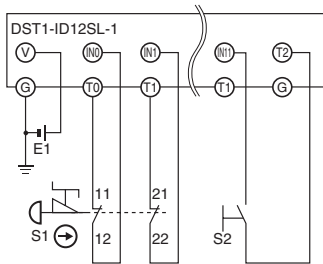

E1: 24-VDC Power Supply (e.g., S8VS)  
 S1: Emergency stop pushbutton switch (direct operation mechanism)  
 S2: Reset switch

● Safety Outputs

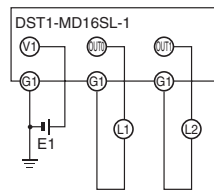

E1: 24-VDC Power Supply (e.g., S8VS)  
 L1 and L2: Loads

● Safety Output and Output Feedback

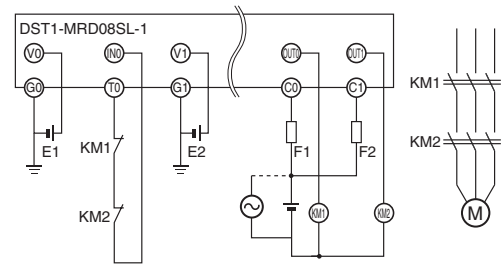

E1: 24-VDC Power Supply (e.g., S8VS)  
 KM1 and KM2: Contactors  
 F1 and F2: Fuses

Dimensions

NE1A-SCPU01

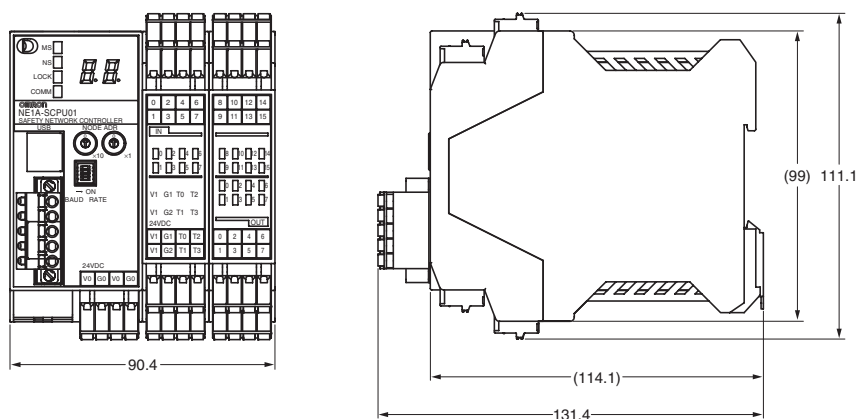

DST1-ID12SL-1  
DST1-MD16SL-1

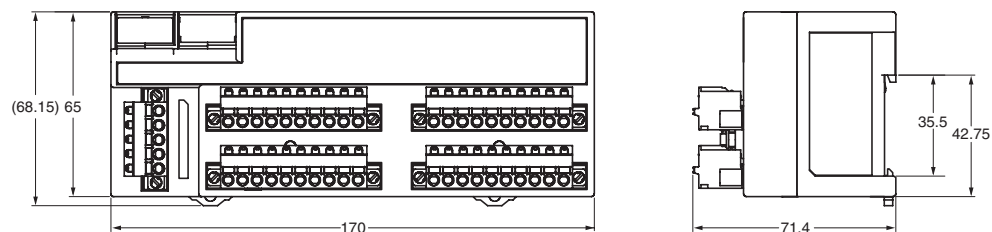

DST1-MRD08SL-1

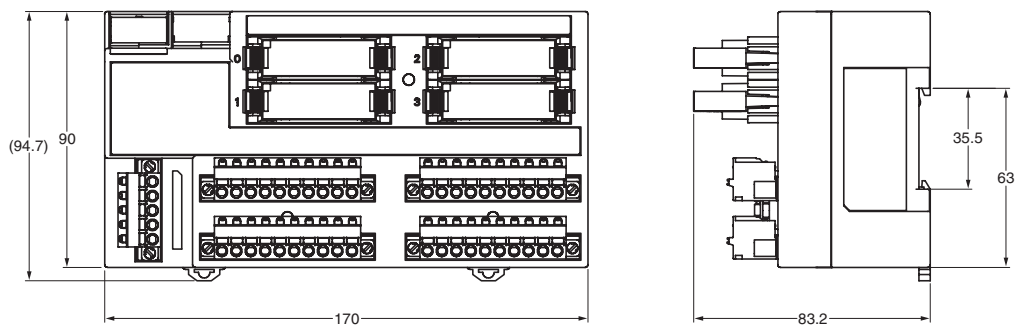

Cat. No. Z907-E2-01-X

**In the interest of product improvement, specifications are subject to change without notice.**

---

**OMRON EUROPE B.V.**

Wegalaan 67-69,  
NL-2132 JD, Hoofddorp,  
The Netherlands  
Phone: +31 23 568 13 00  
Fax: +31 23 568 13 88  
[www.eu.omron.com](http://www.eu.omron.com)