

**G9SP Series**  
**Safety Controller**

**OPERATION MANUAL**

**OMRON**



© **OMRON, 2010**

All rights reserved. No part of this publication may be reproduced, stored in a retrieval system, or transmitted, in any form, or by any means, mechanical, electronic, photocopying, recording, or otherwise, without the prior written permission of OMRON.

No patent liability is assumed with respect to the use of the information contained herein. Moreover, because OMRON is constantly striving to improve its high-quality products, the information contained in this manual is subject to change without notice. Every precaution has been taken in the preparation of this manual. Nevertheless, OMRON assumes no responsibility for errors or omissions. Neither is any liability assumed for damages resulting from the use of the information contained in this publication.



# **G9SP-series Safety Controller:**

**G9SP-N□□□**

## **Operation Manual**

*Revised September 2010*



# Introduction

---

Thank you for purchasing a G9SP-series Safety Controller. This manual contains information required to use the G9SP-series Controller. Please thoroughly read and understand this manual before you use the G9SP-series Controller.

## Intended Audience

This manual is intended for the following personnel, who must also have knowledge of electrical systems (an electrical engineer or the equivalent).

- Personnel in charge of installing FA systems.
- Personnel in charge of designing FA systems.
- Personnel in charge of managing FA systems and facilities.
- Personnel in charge of qualifications and authority in all phases, including system design, installation, operation, maintenance, and disposal.

# Manual Configuration

Information on the operation of G9SP-series Safety Controllers is provided in the following manuals. Refer to the specific manual depending on the information that is required.

Manual name	Contents	Cat. No.
G9SP-series Safety Controller Operation Manual (this manual)	This manual provides detailed specifications and describes functions and application methods for the G9SP-series Controller in detail.	Z922
G9SP-series Safety Controller Instructions Reference Manual	This manual describes the safety programming methods, provides the specifications, and describes the functions and operating methods of the G9SP-series Controllers.	Z923
G9SP-series Safety Controller Host Connection Manual	This manual provides sample ladder programming and describes how to connect to a Standard PLC from another manufacturer using the communications functionality of the G9SP-series Controller's Option Board. The procedure for connecting to a Standard PLC from another manufacturer is described in the G9SP Operation Manual.	Z924

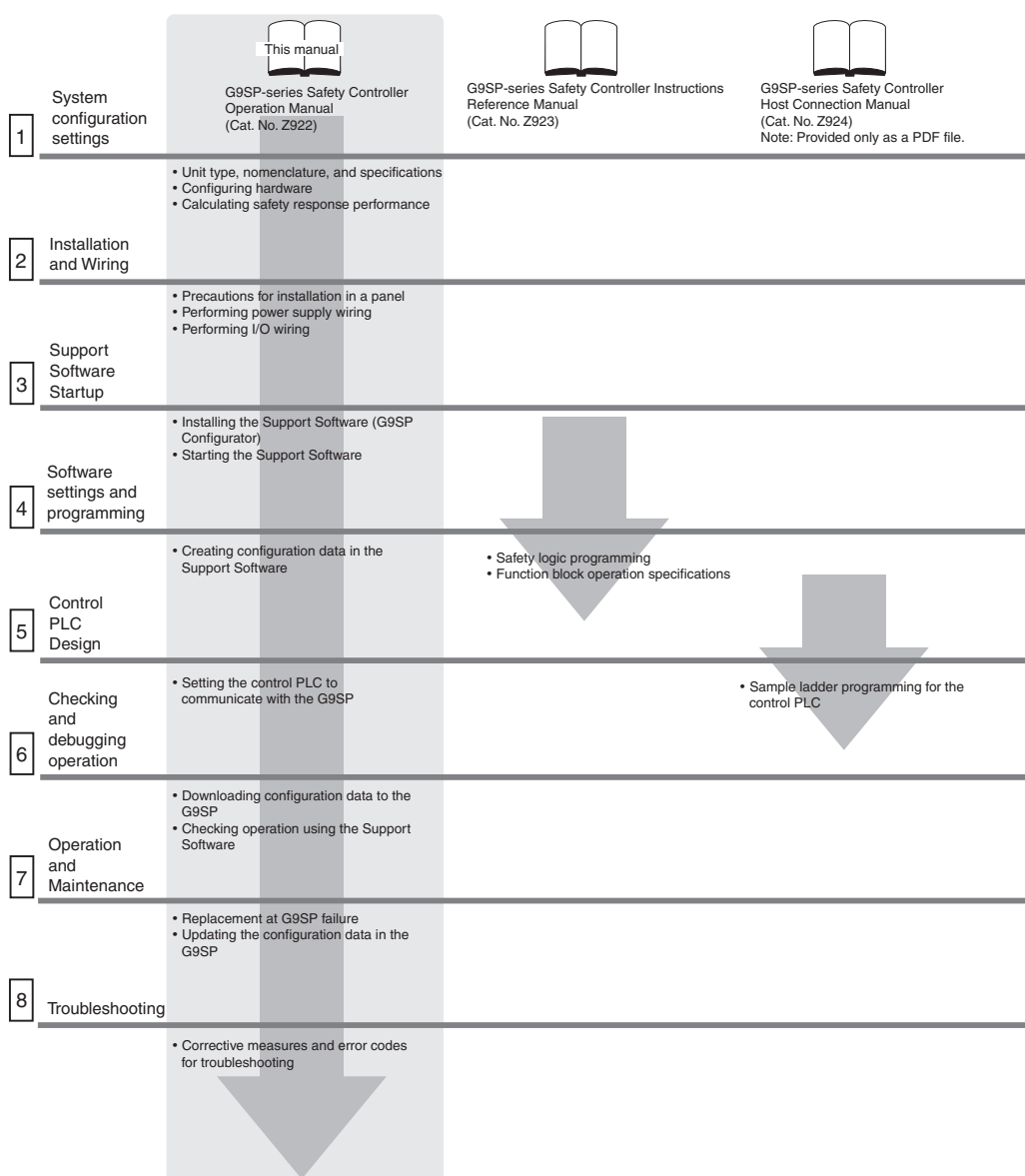



# Sections in this Manual

---

<b>1</b>	Overview	<b>10</b>	Checking Operating Status and Debugging
<b>2</b>	Part Names and Specifications	<b>11</b>	Backup and Restore Data Using Memory Cassette
<b>3</b>	Calculating Response Performance	<b>12</b>	Maintenance and Inspections
<b>4</b>	Installation and Wiring	<b>13</b>	Troubleshooting
<b>5</b>	Preparations for Using the G9SP Configurator	<b>A</b>	Application Templates
<b>6</b>	Creating Configuration Data		
<b>7</b>	Communications with a Standard PLC Using an Option Board		
<b>8</b>	Connecting Online and Downloading to the G9SP-series Controller		
<b>9</b>	Operation and Operating Modes		



# TABLE OF CONTENTS

Introduction .....	vii
Manual Configuration .....	viii
Sections in this Manual .....	ix
Safety Precautions .....	xix
Precautions for Safe Use .....	xxii
Precautions for Compliance with UL Standards and CSA Standards .....	xxv
Regulations and Standards .....	xxvi
Glossary .....	xxviii

## Overview

### SECTION 1

<b>Overview .....</b>	<b>1</b>
1-1 Overview and Features of the G9SP-series Controller .....	2
1-2 Basic Operating Procedures .....	8

## Hardware Settings

### SECTION 2

<b>Part Names and Specifications .....</b>	<b>9</b>
2-1 G9SP-series Controllers .....	10
2-2 Expansion I/O Units .....	36
2-3 Option Units .....	41

### SECTION 3

<b>Calculating Response Performance .....</b>	<b>45</b>
3-1 Startup Time .....	46
3-2 Reaction Times .....	47

### SECTION 4

<b>Installation and Wiring .....</b>	<b>49</b>
4-1 Installation .....	50
4-2 Wiring .....	57

## Software Design

### SECTION 5

<b>Preparations for Using the G9SP Configurator .....</b>	<b>61</b>
5-1 Overview .....	62
5-2 Installation .....	64

# TABLE OF CONTENTS

## SECTION 6

<b>Creating Configuration Data</b> .....	<b>69</b>
6-1 Overview .....	70
6-2 Creating Configuration Data .....	71
6-3 Designing Device Security .....	78
6-4 Offline Simulation .....	83
6-5 Creating and Using User-defined Function Blocks .....	87

## SECTION 7

<b>Communications with a Standard PLC Using an Option Board</b> .....	<b>93</b>
7-1 Functionality for All Option Board's .....	94
7-2 RS-232C Serial Communications .....	105
7-3 Ethernet Communications .....	112

## SECTION 8

<b>Connecting Online and Downloading to the G9SP-series Controller</b> .....	<b>119</b>
8-1 Overview .....	120
8-2 Downloading Configuration Data to the G9SP-series Controller and Verification .....	121
8-3 Uploading Data from the G9SP-series Controller .....	123
8-4 Resetting the G9SP-series Controller .....	124
8-5 Setting a Device Password .....	125

## SECTION 9

<b>Operation and Operating Modes</b> .....	<b>127</b>
9-1 G9SP-series Controller Operating Modes .....	128
9-2 Changing the Operating Mode .....	130
9-3 Configuration Lock and Automatic Operation .....	131
9-4 Changing the Configuration Data .....	133
9-5 Operation for Power Supply Interruptions .....	134

## Startup and Debugging

## SECTION 10

<b>Checking Operating Status and Debugging</b> .....	<b>135</b>
10-1 Monitoring Devices .....	136
10-2 Monitoring Programs .....	140
10-3 Debugging in Force Mode .....	143
10-4 Safety Validation and Preparations for Operation .....	146

# TABLE OF CONTENTS

## Maintenance and Inspections

### SECTION 11

#### **Backup and Restore Data Using Memory Cassette . . . . . 147**

- 11-1 Overview . . . . . 148
- 11-2 Backing Up Data to the Memory Cassette . . . . . 150
- 11-3 Restoring Data to G9SP-series Controller. . . . . 152
- 11-4 Checking Configuration Data Using Indicators . . . . . 155

### SECTION 12

#### **Maintenance and Inspections . . . . . 157**

- 12-1 Inspections . . . . . 158
- 12-2 G9SP-series Controller Replacement Precautions. . . . . 159

### SECTION 13

#### **Troubleshooting . . . . . 161**

- 13-1 Overview of Troubleshooting . . . . . 162
- 13-2 Error Details and Measures . . . . . 165

## Appendices

- A Application Templates . . . . . 169
- B Using the Password Recovery Tool . . . . . 185
- C Calculated Values of PFD and PFH . . . . . 187

#### **Index. . . . . 189**

#### **Revision History . . . . . 191**

# TABLE OF CONTENTS

## ***Read and Understand this Manual***

Please read and understand this manual before using the product. Please consult your OMRON representative if you have any questions or comments.

## ***Warranty and Limitations of Liability***

### ***WARRANTY***

OMRON's exclusive warranty is that the products are free from defects in materials and workmanship for a period of one year (or other period if specified) from date of sale by OMRON.

OMRON MAKES NO WARRANTY OR REPRESENTATION, EXPRESS OR IMPLIED, REGARDING NON-INFRINGEMENT, MERCHANTABILITY, OR FITNESS FOR PARTICULAR PURPOSE OF THE PRODUCTS. ANY BUYER OR USER ACKNOWLEDGES THAT THE BUYER OR USER ALONE HAS DETERMINED THAT THE PRODUCTS WILL SUITABLY MEET THE REQUIREMENTS OF THEIR INTENDED USE. OMRON DISCLAIMS ALL OTHER WARRANTIES, EXPRESS OR IMPLIED.

### ***LIMITATIONS OF LIABILITY***

OMRON SHALL NOT BE RESPONSIBLE FOR SPECIAL, INDIRECT, OR CONSEQUENTIAL DAMAGES, LOSS OF PROFITS OR COMMERCIAL LOSS IN ANY WAY CONNECTED WITH THE PRODUCTS, WHETHER SUCH CLAIM IS BASED ON CONTRACT, WARRANTY, NEGLIGENCE, OR STRICT LIABILITY.

In no event shall the responsibility of OMRON for any act exceed the individual price of the product on which liability is asserted.

IN NO EVENT SHALL OMRON BE RESPONSIBLE FOR WARRANTY, REPAIR, OR OTHER CLAIMS REGARDING THE PRODUCTS UNLESS OMRON'S ANALYSIS CONFIRMS THAT THE PRODUCTS WERE PROPERLY HANDLED, STORED, INSTALLED, AND MAINTAINED AND NOT SUBJECT TO CONTAMINATION, ABUSE, MISUSE, OR INAPPROPRIATE MODIFICATION OR REPAIR.

## ***Application Considerations***

### ***SUITABILITY FOR USE***

OMRON shall not be responsible for conformity with any standards, codes, or regulations that apply to the combination of products in the customer's application or use of the products.

At the customer's request, OMRON will provide applicable third party certification documents identifying ratings and limitations of use that apply to the products. This information by itself is not sufficient for a complete determination of the suitability of the products in combination with the end product, machine, system, or other application or use.

The following are some examples of applications for which particular attention must be given. This is not intended to be an exhaustive list of all possible uses of the products, nor is it intended to imply that the uses listed may be suitable for the products:

- Outdoor use, uses involving potential chemical contamination or electrical interference, or conditions or uses not described in this manual.
- Nuclear energy control systems, combustion systems, railroad systems, aviation systems, medical equipment, amusement machines, vehicles, safety equipment, and installations subject to separate industry or government regulations.
- Systems, machines, and equipment that could present a risk to life or property.

Please know and observe all prohibitions of use applicable to the products.

**NEVER USE THE PRODUCTS FOR AN APPLICATION INVOLVING SERIOUS RISK TO LIFE OR PROPERTY WITHOUT ENSURING THAT THE SYSTEM AS A WHOLE HAS BEEN DESIGNED TO ADDRESS THE RISKS, AND THAT THE OMRON PRODUCTS ARE PROPERLY RATED AND INSTALLED FOR THE INTENDED USE WITHIN THE OVERALL EQUIPMENT OR SYSTEM.**

### ***PROGRAMMABLE PRODUCTS***

OMRON shall not be responsible for the user's programming of a programmable product, or any consequence thereof.



## **Disclaimers**

### ***CHANGE IN SPECIFICATIONS***

Product specifications and accessories may be changed at any time based on improvements and other reasons.

It is our practice to change model numbers when published ratings or features are changed, or when significant construction changes are made. However, some specifications of the products may be changed without any notice. When in doubt, special model numbers may be assigned to fix or establish key specifications for your application on your request. Please consult with your OMRON representative at any time to confirm actual specifications of purchased products.

### ***DIMENSIONS AND WEIGHTS***

Dimensions and weights are nominal and are not to be used for manufacturing purposes, even when tolerances are shown.

### ***PERFORMANCE DATA***

Performance data given in this manual is provided as a guide for the user in determining suitability and does not constitute a warranty. It may represent the result of OMRON's test conditions, and the users must correlate it to actual application requirements. Actual performance is subject to the OMRON Warranty and Limitations of Liability.

### ***ERRORS AND OMISSIONS***

The information in this manual has been carefully checked and is believed to be accurate; however, no responsibility is assumed for clerical, typographical, or proofreading errors, or omissions.





# Safety Precautions

## Definition of Precautionary Information

The following notation is used in this manual to provide precautions required to ensure safe usage of a G9SP-series Controller. The safety precautions that are provided are extremely important to safety. Always read and heed the information provided in all safety precautions.

The keywords and their definitions are as given below.

 <b>WARNING</b>	Indicates a potentially hazardous situation which, if not avoided, will result in minor or moderate injury, or may result in serious injury or death. Additionally there may be significant property damage.
--	--

 <b>Caution</b>	Indicates a potentially hazardous situation which, if not avoided, may result in minor or moderate injury or in property damage.
--	--



### Precautions for Safe Use

Indicates precautions on what to do and what not to do to ensure using the product safely.



### Precautions for Correct Use

Indicates precautions on what to do and what not to do to ensure proper operation and performance.

## Symbols



The circle and slash symbol indicates operations that you must not do. The specific operation is shown in the circle and explained in text.



The filled circle symbol indicates operations that you must do. The specific operation is shown in the circle and explained in text. This example shows a general precaution for something that you must do.

# **WARNING**

This is the *Operation Manual* for the G9SP-series Safety Controllers.

Obey the following warnings during system construction to ensure that safety-related components are configured to enable the system functions to sufficiently operate.

## ● **Risk Assessment**

The proper use of the safety devices described in this manual as they relate to installation conditions and mechanical performance and functions is a prerequisite for its use.

When selecting or using the safety devices, risk assessment must be performed during the development stage of the equipment or facilities to identify potential danger factors in equipment or facilities in which the safety devices are to be applied. Suitable safety devices must be selected under the guidance of a sufficient risk assessment system. An insufficient risk assessment system may result in the selection of unsuitable safety devices.

- Typical related international standards: ISO 14121, Safety of Machinery -- Principles of Risk Assessment

## ● **Safety Measures**

When using this safety device to build systems containing safety-related components for equipment or facilities, the system must be designed with the full understanding of and conformance to international standards, such as those listed below, and/or standards in related industries.

- Typical related international standards: ISO/DIS 12100, Safety of Machinery -- Basic Concepts and General Principles for Design

IEC 61508, Safety Standard for Safety Instrumented Systems (Functional Safety of Electrical/Electronic/Programmable Electronic Safety-related Systems)

## ● **Role of Safety Devices**

The safety devices are provided with safety functions and mechanisms as stipulated in relevant standards, but suitable designs must be used to enable these functions and mechanisms to operate properly inside system constructions containing safety-related components. Build systems that enable these functions and mechanisms to perform properly, based on a full understanding of their operation.

- Typical related international standards: ISO 14119, Safety of machinery -- Interlocking devices associated with guards -- Principles for design and selection

## ● **Installation of Safety Devices**

The construction and installation of systems with safety-related components for equipment or facilities must be performed by technicians who have received suitable training.

- Typical related international standards: ISO/DIS 12100, Safety of Machinery -- Basic Concepts and General Principles for Design

IEC 61508, Safety Standard for Safety Instrumented Systems (Functional Safety of Electrical/Electronic/Programmable Electronic Safety-related Systems)

## ● **Compliance with Laws and Regulations**

This safety device conforms to the relevant regulations and standards, but make sure that it is used in compliance with local regulations and standards for the equipment or facilities in which it is applied.

- Typical related international standards: IEC 60204, Safety of Machinery -- Electrical Equipment of Machines

## ● **Observing Precautions for Use**

When putting the selected safety device to actual use, heed the specifications and precautions in this manual and those in the instruction manual that comes with the product. Using a product in a manner that deviates from these specifications and precautions will lead to unexpected failures in equipment or devices, and to damage that results from such failures, due to insufficient operating functions in safety-related components.













## ● **Moving or Transferring Devices or Equipment**

When moving or transferring devices or equipment, be sure to include this manual to ensure that the person to whom the device or equipment is being moved or transferred will be able to operate it properly.

- Typical related international standards: ISO/DIS 12100, Safety of Machinery -- Basic Concepts and General Principles for Design

IEC 61508, Safety Standard for Safety Instrumented Systems (Functional Safety of Electrical/Electronic/Programmable Electronic Safety-related Systems)

# WARNING

Electric shock may occur. Do not touch any terminals while power is being supplied.	
Serious injury may possibly occur due to loss of required safety functions. Do not use the G9SP-series Controller's test outputs or standard outputs as safety outputs.	
Serious injury may possibly occur due to loss of required safety functions. Do not use the G9SP-series Controller's network data as safety data.	
Serious injury may possibly occur due to loss of required safety functions. Do not use indicators on the G9SP-series Controller for safety operations.	
Serious injury may possibly occur due to breakdown of safety outputs or test outputs. Do not connect loads beyond the rated values to the safety outputs and test outputs.	
Serious injury may possibly occur due to loss of required safety functions. Wire the G9SP-series Controller properly so that the 24VDC line does NOT touch the outputs accidentally or unintentionally.	
Serious injury may possibly occur due to loss of required safety functions. Ground the 0V line of the power supply for external output devices so that the devices do NOT turn ON when the safety output line or the test output line is grounded.	
Serious injury may possibly occur due to loss of required safety functions. Perform user testing and confirm that all of the G9SP-series Controller's configuration data and operation is correct before starting system operation.	
Serious injury may possibly occur due to loss of required safety functions. When replacing a G9SP-series Controller, confirm the model of the Controller is correct and configure the replacement Controller suitably and confirm that it operates correctly.	
Serious injury may possibly occur due to loss of required safety functions. Once the data has been restored from the Memory Cassette, check that the configuration data of the G9SP-series Controller is correct in that it operates properly and carry out the validation testing (User Testing).	
Outputs may operate, possibly resulting in serious injury. Take sufficient safety measures before force-setting or force-resetting variables in the program.	
Serious injury may possibly occur due to loss of required safety functions. Use devices and parts related to safety functions according to legal regulations in the applicable country. Use certified items compliant with safety standards corresponding to the intended application.	

# Precautions for Safe Use

---

## ● Handling

Do not drop the G9SP-series Controller or subject it to excessive vibration or mechanical shock. The G9SP-series Controller may be damaged and may not function properly.

## ● Installation and Storage Environment

Do not use or store the G9SP-series Controller in any of the following locations:

- Locations subject to direct sunlight
- Locations subject to temperatures or humidity outside the range specified in the specifications
- Locations subject to condensation as the result of severe changes in temperature
- Locations subject to corrosive or flammable gases
- Locations subject to dust (especially iron dust) or salts
- Locations subject to water, oil, or chemicals
- Locations subject to shock or vibration

Take appropriate and sufficient measures when installing systems in the following locations. Inappropriate and insufficient measures may result in malfunction.

- Locations subject to static electricity or other forms of noise
- Locations subject to strong electromagnetic fields
- Locations subject to possible exposure to radioactivity
- Locations close to power supplies

This is a class A product designed for use in industrial environments. In residential areas it may cause radio interference, in which case the user may be required to take adequate measures to reduce interference.

## ● Installation and Mounting

- Use the G9SP-series Controller within an enclosure with IP54 protection or higher according to IEC/EN 60529.
- Use DIN Track (TH35-7.5/TH35-15 according to IEC 60715) or M4 screws with a tightening torque of 1.2 N·m (10.5 lb·in) to install the G9SP-series Controller into the control panel.
- Mount the G9SP-series Controller to the DIN Track using PFP-M End Plates (not included with the G9SP-series Controller) to prevent it from falling off the DIN Track because of vibration. Correctly mount all Units to DIN Track.
- Install the G9SP-series Controller in the vertical direction shown below to ensure adequate cooling.

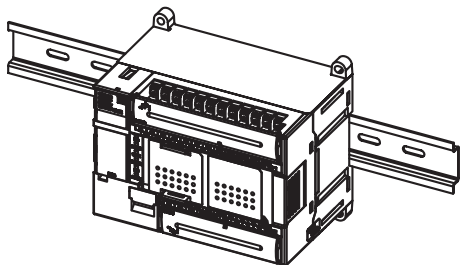

- Space must be provided around the G9SP-series Controller, at least 20 mm from its side surfaces and at least 50 mm from its top and bottom surfaces, for ventilation, wiring and Unit replacement.
- Be sure to lock all locking mechanisms, such as those on I/O terminal blocks and connectors, before attempting to use the G9SP-series Controller.

Turn OFF the power supply before performing any of the following.

- Connecting or disconnecting Expansion I/O Units, Option Boards, or any other Units
- Assembling the G9SP-series Controller
- Connecting cables or wiring
- Connecting or removing terminal blocks

## ● Installation and Wiring

- Use the following to wire external I/O devices to the G9SP-series Controller.

Solid wire	0.32 to 0.82 mm <sup>2</sup> AWG22 to AWG18 0.32 to 0.5 mm <sup>2</sup> AWG22 to AWG20*1
Stranded wire	0.5 to 1.3 mm <sup>2</sup> AWG20 to AWG16 0.5 to 0.82 mm <sup>2</sup> AWG20 to AWG18*1

\*1: When wiring two wires to one terminal. Use two wires of the same type and thickness.

- M3 self-rising screws are used for all screw terminals.
- Tighten the terminal block screws to a torque of 0.5 N·m (4.4 lb·in).
- Disconnect the G9SP-series Controller from the power supply before starting wiring. Devices connected to the G9SP-series Controller may operate unexpectedly.
- Properly apply the specified voltage to the G9SP-series Controller inputs. Applying an inappropriate DC voltage or any AC voltage will cause the G9SP-series Controller to fail.
- Be sure to separate the communications cables and I/O cables from high-voltage/high-current lines.
- Be cautious not to get your fingers caught when attaching connectors to the plugs on the G9SP-series Controller.
- Incorrect wiring may lead to loss of safety functions. Wire conductors correctly and verify the operation of the G9SP-series Controller before using the system in which the G9SP-series Controller is incorporated.
- Lock the connectors on Option Units or Expansion I/O Units before using the Units.
- After wiring is completed, be sure to remove the label for wire clip entry prevention from the G9SP-series Controller to enable heat to escape for proper cooling.
- Do not ground the 24-V side of the power supply to the G9SP-series Controller. If you do so, an unwanted current flow shown in the following diagram may occur when you connect a computer or other peripheral device.

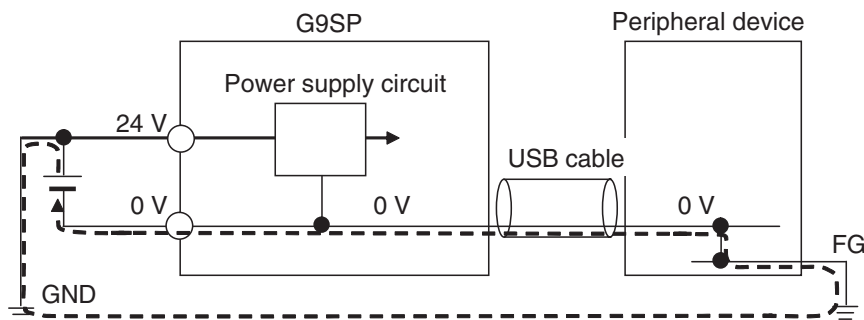

- Connect no more than the specified number of Expansion I/O Units.

## ● Power Supply Selection

Use a DC power supply satisfying the following requirements.

- The secondary circuit of the DC power supply must be isolated from the primary circuit by double insulation or reinforced insulation.
- The output characteristic requirements defined in UL 508 for class 2 circuits or control voltage current circuits are satisfied.
- The output hold time must be 20 ms or longer.
- The DC power supply must be an SELV power supply that satisfies the requirements of IEC/EN 60950-1 and EN 50178.

## ● Periodic Inspections and Maintenance

- Disconnect the G9SP-series Controller from the power supply before replacing the Controller. Devices connected to the G9SP-series Controller may operate unexpectedly.
- Do not disassemble, repair, or modify the G9SP-series Controller. Doing so may lead to loss of safety functions.

## ● Disposal

Be cautious not to injure yourself when dismantling the G9SP-series Controller.



# Precautions for Compliance with UL Standards and CSA Standards

Use the following installation information instead of the general information in the instruction manual in order to use the product under certified conditions of UL and CSA when the product is installed in the USA or Canada. These conditions are required by NFPA 70 (National Electrical Code in the USA) and Part 1 of the Canadian Electrical Code in Canada and may vary from information given in the product manuals or safety precautions. G9SP-series Controllers have not been evaluated by UL as Programmable Safety Controllers, and the Safety functions of these devices have not been evaluated by UL as well.

- Surrounding air temperature: 55°C
- Do not use crimp terminals for field wiring.
- The DC power supply must satisfy the requirements for an isolated power supply with external 8 A overcurrent protection.
- Do not use the +5 V output from the CP1W-CIF01 for anything other than the NT-AL001.
- A G9SP-series Controller has two sets of power supply terminals, one for the main power and one for I/O power. Connect both of them to the same power source.

## ● Ratings

Controller	Rating for UL
G9SP-N20S	Source: 24 V dc, 500 mA, isolated source Input: 24 V dc, 6 mA /P, 20 points Output: 24 V dc (GEN) (P.D.), 0.8 A /P, 8 points Rated total currents of So0 to 3, So4 to 7 are 1.6 A each Test Output: T0 – T2: 24 V dc (GEN), 100 mA T3: 24 V dc (GEN)(TUN), 300 mA T4, T5: 24 V dc (GEN), 30 mA Rated total currents of T0 – T2, T4 and T5 are 120 mA
G9SP-N10D	Source: 24 V dc, 500 mA, isolated source Input: 24 V dc, 6 mA, 10 points Output: 24 V dc (GEN) (P.D.), 0.8 A /P, 16 points Rated total currents of So0 to 3, So4 to 7, So8 to 11, So12 to So15 are 1.2 A each Test Output: T0 – T2: 24 V dc (GEN), 60 mA T3: 24 V dc (GEN)(TUN), 300 mA T4, T5: 24 V dc (GEN), 30 mA Rated total currents of T0 – T2, T4 and T5 are 60 mA
G9SP-N10S	Source: 24 V dc, 400 mA, isolated source Input: 24 V dc, 6 mA /P, 10 points Output: 24 V dc (GEN) (P.D.), 0.8 A /P, 1.6 A /Unit, 4 points Test Output: T0, T1: 24 V dc (GEN), 60 mA T2: 24 V dc (GEN), 30 mA T3: 24 V dc (GEN)(TUN), 300 mA Rated total currents of T0 – T2 are 60 mA Standard Output: 24 V dc (GEN), 100 mA, 4 points

## ● TERMINAL MARKINGS

Terminals	Function
V1/G1	Power supply terminals for Internal/Input circuits (24 VDC).
V2/G2	Power supply terminals for output circuits (24 VDC).
NC	Not used (Do not connect)
Si0 to Si19	Input terminals
T0 to T5	Test output terminals
So0 to So15	Output terminals
O0 to O3	Standard output terminals

# Regulations and Standards

The G9SP-series Controller has obtained certification for the following standards.

Certifying body	Standards
TÜV Rheinland	<ul style="list-style-type: none"> <li>• EN ISO 13849-1:2008</li> <li>• EN ISO 13849-2:2008</li> <li>• IEC 61508 parts 1-7:2010</li> <li>• IEC/EN 62061:2005</li> <li>• IEC 61131-2:2007</li> <li>• EN ISO 13850:2008(EN418:1992)</li> <li>• EN 60204-1:2006</li> <li>• EN 61000-6-2:2005</li> <li>• EN 61000-6-4:2007</li> <li>• NFPA 79-2007</li> <li>• ANSI RIA 15.06-1999</li> <li>• ANSI B11.19-2003</li> <li>• UL1998</li> </ul>
UL	<ul style="list-style-type: none"> <li>• UL508</li> <li>• CSA22.2 No.142</li> </ul>
Others	<ul style="list-style-type: none"> <li>• CE Marking</li> <li>• C-Tick mark</li> </ul>

Using a G9SP-series Controller enables building a safety control system that satisfy the following:

- Requirements for SIL 3 (Safety Integrity Level 3) in IEC 61508, IEC/EN 62061, Safety Standard for Safety Instrumented Systems (Functional Safety of Electrical/Electronic/Programmable Electronic Safety-related Systems)
- Requirements for PLe (Performance Level e) and for safety category 4 in EN ISO13849-1

## Compliance with EC Directives

### Applicable Directives

- EMC Directive (2004/108/EC)
- Machinery Directive (2006/42/EC)

### Concepts

#### ● EMC Directive

OMRON electrical devices are built into other components or equipment. OMRON therefore pursues compliance with the related EMC standards so that they can be more easily built into other devices or the equipment.\*

OMRON cannot confirm compliance in the customer's actual application, however, because the customer may use a variety of components and equipment, and EMC performance depends on the configuration, wiring, and arrangement of the equipment and control panel into which a product applicable to EC Directives is incorporated. Therefore, whether the products conform to the standards in the system used by the customer must be checked by the customer.

\* Applicable EMC (Electromagnetic Compatibility) standards are as follows: EN 61000-6-2 for EMS (Electromagnetic Susceptibility) and EN 61000-6-4 for Electromagnetic Interference (10-m regulations applied for EN 61000-6-4 radiated emission).

## ● Machinery Directive

The Machinery Directive requires ensuring the required safety for safety components used for machinery safety.

Applicable standards: EN ISO 13849-1:2008 and IEC/EN 62061 SIL CL3

## ● Conformance to EC Directives

The G9SP-series Controller complies with EC Directives. To ensure that the machine or device in which the G9SP-series Controller is used complies with EC Directives, the following requirements must be met.

- Make sure that the DC power supply connected to a DC Power Supply Unit or I/O Unit satisfies the following conditions.
  - There is double insulation or reinforced insulation between the primary circuit and secondary circuit.
  - An isolated power supply that is limited to a current of 8 A or lower must be used.
  - The output hold time is 20 ms min.
  - The power supply is a SELV power supply that satisfies requirements in IEC/EN 60950-1 and EN 50178.
- G9SP-series products that comply with the EC Directives also comply with the Generic Emission Standard (EN 61000-6-4) for EMI. The radiated emission characteristics (10-m regulations), however, may depend on the configuration of the control panel that is used and the relation to and wiring with other connected devices. Even through the G9SP-series Controller complies with EC Directives, the customer must confirm that the overall machinery and equipment in which the G9SP-series Controller is used complies with the EC Directives.

## EN ISO 13849-1 and IEC/EN 62061 Compliance

EN ISO 13849-1 and IEC/EN 62061 require process management to avoid system interference and to simplify reading, understanding, testing, and maintaining software. This is required in all phases of the life cycle of software programming and software design (e.g., basic software design, safety circuit system design, and software upgrades) in safety control systems to be developed using safety controllers. Therefore, process management is required for design and development of software for facilities and equipment that use the function blocks provided in the Safety Controller.

The customer must implement measures to ensure compliance with these standards.

## Registered Trademarks

Windows is a registered trademark of Microsoft Corporation.

Other system names and product names in this manual are the trademarks or registered trademarks of their respective companies.

# Glossary

The following terms are used in this manual to describe the function blocks of the G9SP-series Safety Controllers.

## Terminology

Term	Definition
Safety	Describes a device, function, data, or other element for which special safety measures have been implemented for use in Safety Controls.
Standard	Describes a device, function, data, or other element that is used in Standard Controls. Used to differentiate from devices, functions, data, or other elements for which special safety measures have been implemented for use in Safety Controls.
Safety Controller	A highly reliable controller that is used in Safety Controls.
Standard PLC	A programmable controller (PLC) that is used for general controls. Used to differentiate from a PLC used for Safety Controls.
Expansion I/O Unit	The name of the CP1W-20EDT(-1) and CP1W-32ET(-1). Some of the OMRON CP1-series Expansion I/O Units can be used in a G9SP-series Controller. Expansion I/O Units are connected to a G9SP-series Controller to increase the number of Standard I/O points.
Option Board	The name of the CP1W-CIF01 and CP1W-CIF41. Some of the OMRON CP1-series Option Boards can be used in a G9SP-series Controller. An Option Board can be mounted in a G9SP-series Controller to communicate with a Standard PLC.
Memory Cassette	The name of the CP1W-ME05M. This OMRON CP1-series Memory Cassette can be used in a G9SP-series Controller. It is used to back up and restore configuration data in G9SP-series Controllers.
G9SP Configurator	The name of the WS02-G9SP-series. Support Software that is used to set up, program, and debug G9SP-series Controllers.
configuration data	Setup data that is used to operate a G9SP-series Controller. The configuration data is created with the G9SP Configurator and then downloaded from the computer to memory in the G9SP-series Controller. The configuration data contains the unit configuration settings, I/O terminal settings, system settings, and Safety Program. Refer to <i>SECTION 6 Creating Configuration Data</i> for details.
backup	An operation used to write the configuration data stored in internal memory in the G9SP-series Controller to a Memory Cassette.
restore	An operation used to write the configuration data stored in a Memory Cassette to internal memory in the G9SP-series Controller.
Safety Input Device	An input device for which special safety measures have been implemented for use in Safety Controls. Safety Input Device is therefore a generic term for input devices such as emergency stop switches and safety door switches.
Safety Output Device	An output device for which special safety measures have been implemented for use in Safety Controls. Safety Output Device is therefore a generic term for output devices such as safety relays.
CP Series	A series of programmable controllers manufactured by OMRON.
NE1A Series	A series of Safety Network Controllers manufactured by OMRON. NE1A-series Controllers are high-end controllers in comparison to the G9SP-series Controllers.
dual channels	Two channels that are used for redundancy with Safety Inputs or Safety Outputs. If the two channels must have the same value, they are called equivalent dual channels. If they must have the opposite values, they are called complementary dual channels.
discrepancy	The state in which the status of two dual channels do not agree, resulting in a discrepancy error.

## Acronyms

Acronym	Meaning
PFD	Probability of Failure on Demand. Refer to <i>Appendix B Using the Password Recovery Tool</i> for details.
PFH	Probability of Failure per Hour. Refer to <i>Appendix B Using the Password Recovery Tool</i> for details.
MC	Memory Cassette.
Si	Safety Input. An input from a Safety Input terminal. This term is used to differentiate from a Standard Input (IN).
So	Safety Output. An output from a Safety Output terminal. This term is used to differentiate from a Standard Output (OUT).
To	Test Output. An output from a Test Output terminal used to diagnose a Safety Input terminal by outputting a test pulse.



## Overview

# SECTION 1 Overview

This section provides an overview and describes the features, system configuration, and application procedures for the G9SP-series Controller.

1-1	Overview and Features of the G9SP-series Controller .....	2
1-1-1	Overview .....	2
1-1-2	Basic System and Configuration Devices .....	2
1-1-3	Features .....	5
1-2	Basic Operating Procedures .....	8

# 1-1 Overview and Features of the G9SP-series Controller

## 1-1-1 Overview

The G9SP-series Safety Controller is a programmable controller that is designed for easy operation in small to mid-sized Safety Control systems.

Using the G9SP-series Safety Controller enables building Safety Control systems that satisfy the requirements for SIL 3 (Safety Integrity Level 3) in IEC 61508 (Safety Standard for Safety Instrumented Systems: Functional Safety of Electrical/Electronic/Programmable Electronic Safety-related Systems) and IEC/EN 62061 (Safety of Machinery -- Functional Safety of Safety-related Electrical, Electronic and Programmable Electronic Control Systems), as well as safety category 4 and PLe (Performance Level e) in EN ISO 13849-1.

The use of Expansion I/O Units and optional products enables a wide variety of applications.

## 1-1-2 Basic System and Configuration Devices

This section describes the basic system configuration for a G9SP-series Controller.

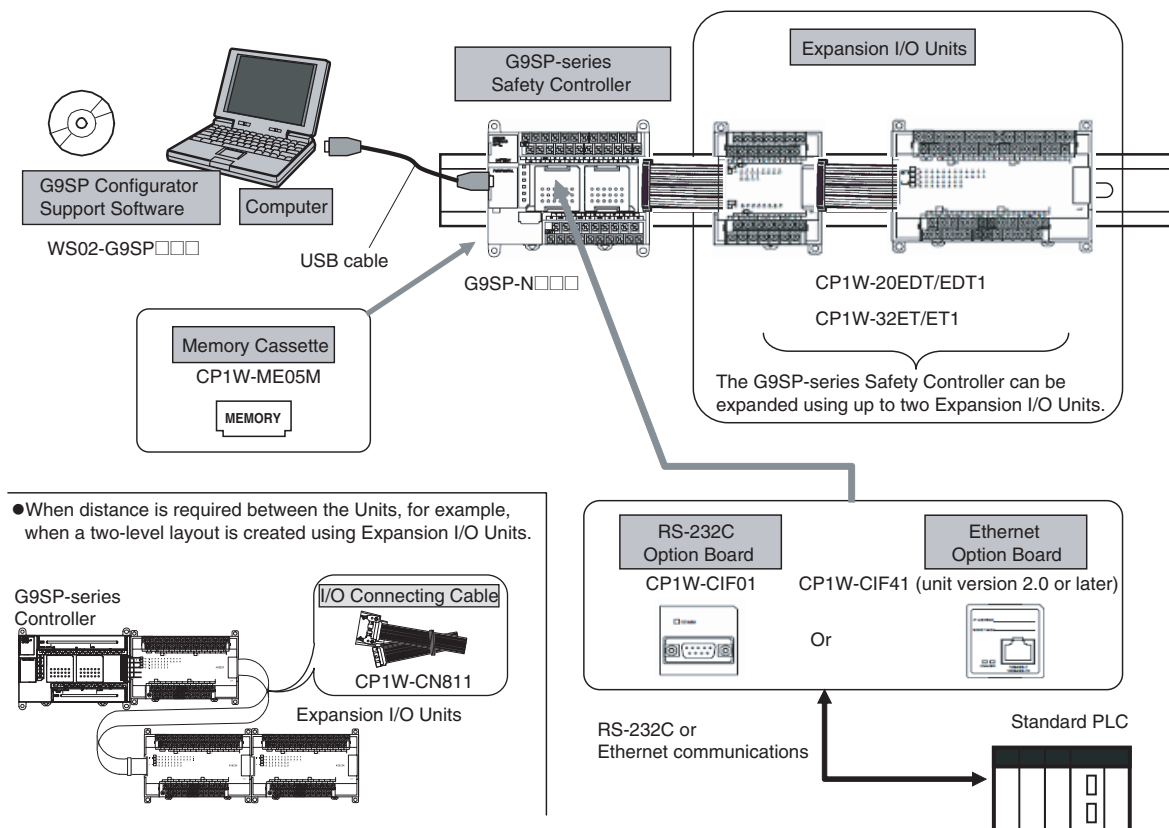



### G9SP-series Controller

There are three models of G9SP-series Controllers depending on the number of Safety I/O points.

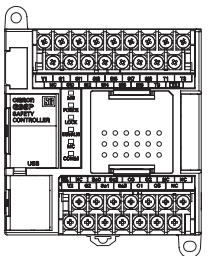
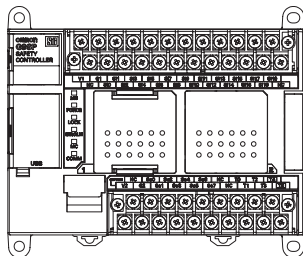
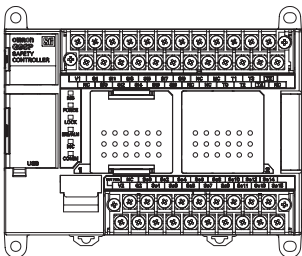
Name/model		G9SP-N10S	G9SP-N10D	G9SP-N20S
Appearance		 W66 x H110 x D65 (mm)	 W130 x H110 x D85 (mm)	 W130 x H110 x D85 (mm)
Power supply		24 VDC		
Program size		Function blocks: 128 max.		
Number of I/O points	Safety Inputs	10 points	10 points	20 points
	Safety Outputs	4 semiconductor outputs	16 semiconductor outputs	8 semiconductor outputs
	Test Outputs	4 points	6 points	6 points
	Standard Inputs	None	None	None
	Standard Outputs	4 semiconductor outputs	None	None
Expansion using Expansion I/O Units		Up to 2 Expansion I/O Units can be mounted.		
Mounting Option Boards		One Option Board can be mounted.		
Using Memory Cassettes		Supported		
Mounting a battery		Not supported		

### Unit Versions of G9SP-series Controller

A “unit version” has been introduced to manage G9SP-series Controllers according to differences in functionality accompanying Controller upgrades.

- Notation of Unit Versions on Products

The unit version is given to the right of the lot number on the nameplate of the products for which unit versions are being managed, as shown below.

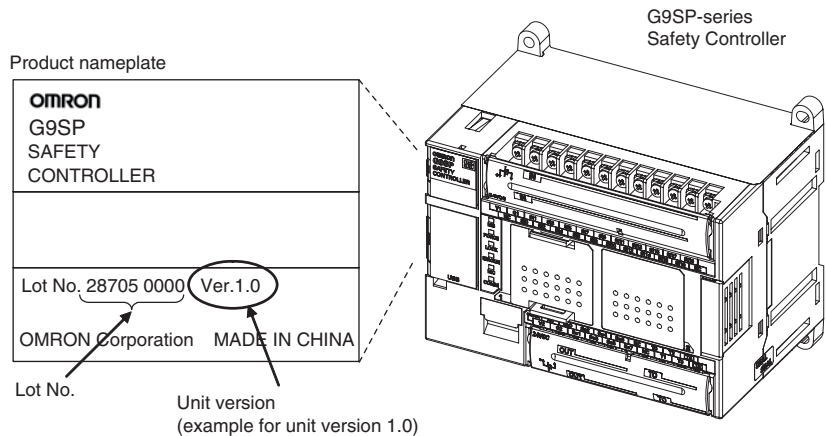

- Confirming Unit Versions with the G9SP Configurator

You can check the unit version by right-clicking the unit name in the Project Window and selecting **Properties** from the G9SP Configurator.

■ Unit Versions

Unit	Model numbers	Unit version
G9SP-series Controller	G9SP-N□□□	Unit version 1.0

**Expansion I/O Units**

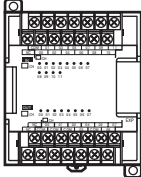
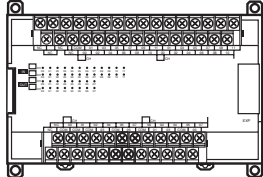

The following four models of CP-series Expansion I/O Units can be used. The CP1W-CN811 I/O Connecting Cable can also be used.

Name/model		Unit with 20 Standard I/O points		Unit with 32 Standard I/O points	
		CP1W-20EDT	CP1W-20EDT1	CP1W-32ET	CP1W-32ET1
Appearance		 W86 x H110 x D50 (mm)		 W150 x H110 x D50 (mm)	
Number of I/O points	Standard Inputs	12 points		None	
	Standard Outputs	8 semiconductor outputs (sinking)	8 semiconductor outputs (sourcing)	32 semiconductor outputs (sinking)	32 semiconductor outputs (sourcing)

**Option Units**

**Option Boards**

The following two models of CP-series Option Boards can be used.

Name/model	RS-232C Option Board	Ethernet Option Board
	CP1W-CIF01	CP1W-CIF41 (unit version 2.0 or later)
Appearance		
Protocol	No-protocol	UDP/IP*1

\*1 Communications with an OMRON Standard PLC can be performed using FINS/UDP.

**Memory Cassette**

The CP1W-ME05M CP-series Memory Cassette can be used.

**I/O Connecting Cable**

Only one CP-series I/O Connecting Cable can be used. Use this cable when the length of the cable for the Expansion I/O Units is insufficient or when the Units are arranged vertically.

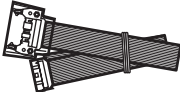
Name/model	I/O Connecting Cable
	CP1W-CN811
Appearance	
Length	800 (mm)

**Precautions for Correct Use**

Operation may be unpredictable if any Units other than the Expansion I/O Units and Option Units listed here are used. Confirm the model before connecting a Unit

**1-1-3 Features****Safety Logic Operation**

Programming can be performed using function blocks that have been certified for safety standards. This enables achieving a wide variety of safety applications ranging from a simple total stop to complex applications that use multiple operating modes.

**Safety I/O**

The Safety I/O terminals of the G9SP-series Controller include a variety of self-diagnosis functions to detect faults and wiring mistakes in connected Safety Devices.

**Wide Range of I/O Wiring Error Detection Functions**

- For Safety Inputs, external wiring errors, such as faulty connected devices, wiring mistakes, disconnected wires, short-circuiting, and ground faults, can be detected.
- Using Safety Outputs in combination with the safety logic EDM function enables detecting errors such as contact weld faults, wiring mistakes, disconnected wires, short-circuiting, and ground faults, in output devices such as Safety Relays and Safety Contactors.

**Direct Connection to Safety Devices**

A direct connection can be made to an OMRON UM Safety Mat, a D40A or D40Z Non-contact Switch, or an E3ZS/E3FS Single Beam Safety Sensor. Connecting without use of an intermediate special controller enables reducing control panel size and decreasing system costs.

**Expanded Support for Applications Using Optional Devices**

Using optional devices enables building the most appropriate and flexible systems.

**Connection to a Standard PLC Using an Option Board**

General-purpose communications can be performed with a Standard PLC using an Option Board. Option Boards are available for the widely used RS-232C serial communications and Ethernet communications, thereby reducing additional system costs.

**Adding Standard I/O Using Expansion I/O Units**

Using Standard Expansion I/O Units enables achieving signal transfer with Standard Control at a low cost.

**Support Software for Robust Support from Design to Startup**

Efficiency from design to startup can be greatly improved by using the functions of the G9SP Configurator.

**Operation Guide and Help for Easier Application of the G9SP Configurator**

**Creating Program Components Using User-defined Function Blocks**

- User-defined function blocks created using the G9SP-series Controller can be reused as program components.

**Desktop Debugging with Offline Simulation and Powerful Search Functions**

- Offline simulation of programs in the Program Creation Window enables increasing programming quality before downloading to the G9SP-series Controller.
- Programming can be efficiently analyzed using search functions, such as searching for I/O tags or unconnected function blocks.

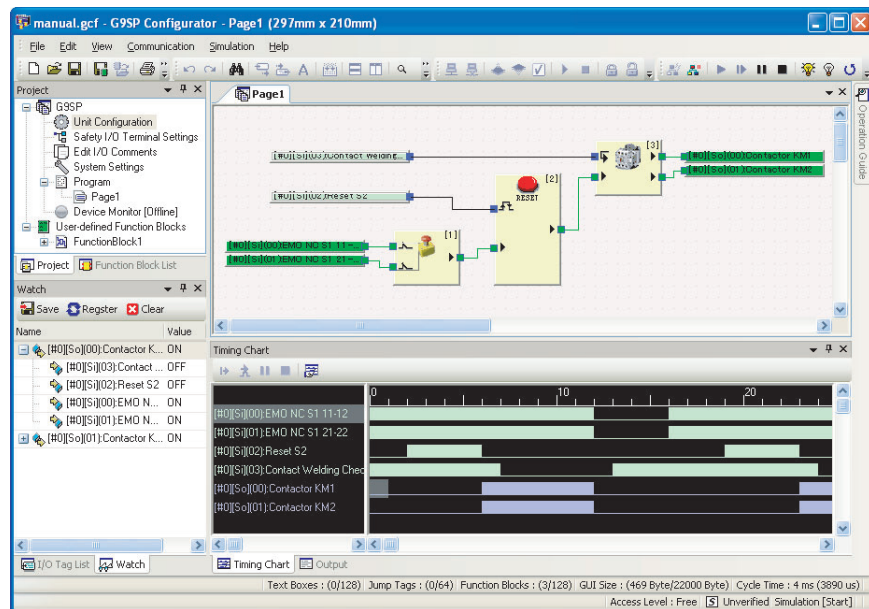

**Identifying Devices with Errors Using Online Monitoring**

- You can detect errors, such as power supply voltage drops, faulty I/O wiring, and Safety Relay welding faults, and then check the cause and countermeasures.

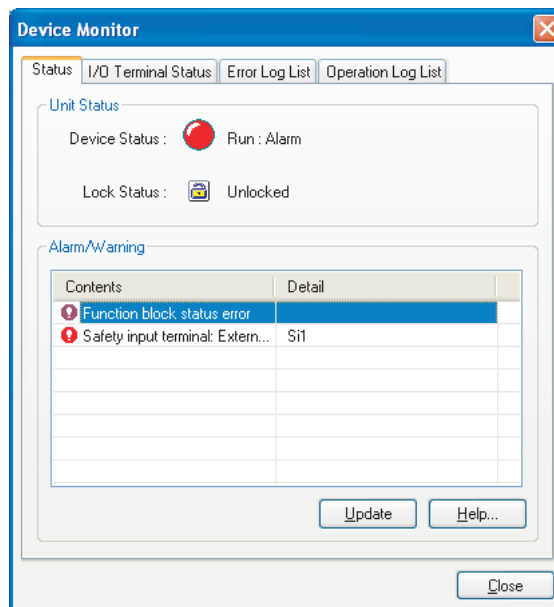

**Force-setting/Force-resetting**

- Force-setting/resetting lets you turn the I/O tags ON and OFF in the program regardless of whether I/O devices and communications data are ON or OFF. During system development, programming can be debugged without I/O devices and remote communications. This also enables efficient checking of output wiring.

**Improved Maintenance Efficiency**

The G9SP-series Controller is equipped with a variety of functions to minimize system downtime if an error occurs. This helps improve production efficiency by preventing unnecessarily stopping the system.

**Continued Operation of Error-free Areas**

Even if an error occurs, the G9SP-series Controller will immediately identify the location of the error and stop only the parts affected by the error, while parts without errors will continue to operate. For example, if a short-circuit fault occurs in I/O wiring, only the outputs related to the Safety Devices that are connected there will stop.

**Information to Identify Causes of Stopping**

You can quickly identify the cause of stopping by using the two-color indicators on the G9SP-series Controller as well as the error log and operation log in the G9SP Configurator.

**Backup and Restore Data Using Optional Memory Cassettes**

A Memory Cassette can be used when replacing the G9SP-series Controller or updating the program. This enables easily replacing and restoring the G9SP-series Controller without directly using the G9SP Configurator.

**Access Management Using Passwords**

Passwords in the G9SP-series Controller and G9SP Configurator can be used to prevent unintended changes to the configuration data at the work site.

**Access Management Using Device Password**

Configuration data that has been downloaded to the G9SP-series Controller is protected using a password set in the Controller. Changes to configuration data using the Memory Cassette can also be prohibited.



**Access Management Using Parameter Passwords**

Access to project files created by the G9SP Configurator can also be managed using passwords. This prevents unintended changes to project files as well as disabling access to configuration data uploaded from the G9SP-series Controller.

# 1-2 Basic Operating Procedures

Generally, the following procedures are used for operation.



## System Design

1. Determining Safety Measures by Conducting Risk Assessment
  2. Selecting Safety Devices
  3. Designing Device Security
  4. Designing Interface with Control Device (Standard PLC)
- }  Section 2 Part Names and Specifications
  - }  6-3 Designing Device Security
  - }  Section 7 Communications with a Standard PLC Using an Option Board

## Hardware Design

Wiring and safety response performance of connection I/O devices are verified according to I/O terminal allocations in the configuration reports.

1. Determining Wiring for Power Supply, Connected I/O Devices, and Communications
2. Calculating and Verifying Safety Response Performance
3. Installation and Wiring

-  Section 2 Part Names and Specifications
-  Section 3 Calculating Response Performance
-  Section 4 Installation and Wiring



## Software Design

Configuration data is created and debugged on a computer using the G9SP Configurator.

1. Preparations and Starting the G9SP Configurator
2. Creating Configuration Data
  - Settings are made for hardware (e.g., unit configuration and I/O terminal settings), programming, and the system.
3. Displaying and Printing Reports
  - The settings are given in the configuration report and passed to the hardware designer.

### 4. Desktop Debugging

Programming is debugged in advance using offline simulation and searches.

-  Section 5 Preparations for Using the G9SP Configurator
-  Section 6 Creating Configuration Data





## Startup and Debugging

The G9SP-series Controller and the computer are connected, and then configuration data is downloaded, debugged, and checked for correct operation.



1. Connecting Online and Downloading to the G9SP-series Controller
2. Controller Trial Operation (Checking and Debugging Operating Status)
  - Checking is performed to confirm that the G9SP-series Controller operates as intended by checking wiring using force-setting/resetting and monitoring program operation.
3. Conducting Safety Validation Testing
  - Once debugging has been completed, checking is performed to validate that all safety functions are operating correctly.
4. Preparations for Operation

Finally, preparations for operation are performed.

- Once the safety confirmation testing has been completed, the configuration data is locked.
- Configuration data is backed up to a Memory Cassette to prepare for replacing the G9SP-series Controller whenever necessary.
- A report of the final configuration data is output and stored.

-  Section 8 Connecting Online and Downloading to the G9SP-series Controller
-  Section 9 Operation and Operating Modes
-  Section 10 Checking Operating Status and Debugging
-  Section 11 Backup and Restore Data Using Memory Cassette

## Operation, Maintenance, and Inspection

1. Equipment Operation
  2. Troubleshooting
  3. Inspection and Replacement
-  Section 11 Backup and Restore Data Using Memory Cassette
  -  Section 12 Inspections and Maintenance
  -  Section 13 Troubleshooting

**SECTION 2**  
**Part Names and Specifications**

This section provides the names of G9SP-series Controller parts, specifications, and terminal arrangements.

2-1	G9SP-series Controllers .....	10
2-1-1	Part Names and Indicators .....	10
2-1-2	Terminal Arrangements .....	14
2-1-3	General Specifications .....	15
2-1-4	I/O Specifications .....	15
2-1-5	Safety Inputs .....	18
2-1-6	Safety Outputs .....	30
2-2	Expansion I/O Units .....	36
2-2-1	Part Names and Indicators .....	36
2-2-2	Terminal Arrangements .....	37
2-2-3	I/O Specifications .....	38
2-2-4	Current Consumption .....	40
2-3	Option Units .....	41
2-3-1	RS-232C Option Board (CP1W-CIF01).....	41
2-3-2	Ethernet Option Board (CP1W-CIF41) .....	42
2-3-3	Memory Cassette (CP1W-ME05M) .....	43

## 2-1 G9SP-series Controllers

This section provides the names of Controller parts, I/O specifications, and terminal arrangements. Refer to 4-1 *Installation* for dimensions and weights and 4-2 *Wiring* for wiring diagrams.

### 2-1-1 Part Names and Indicators

#### Nomenclature and Functions

##### G9SP-N10S

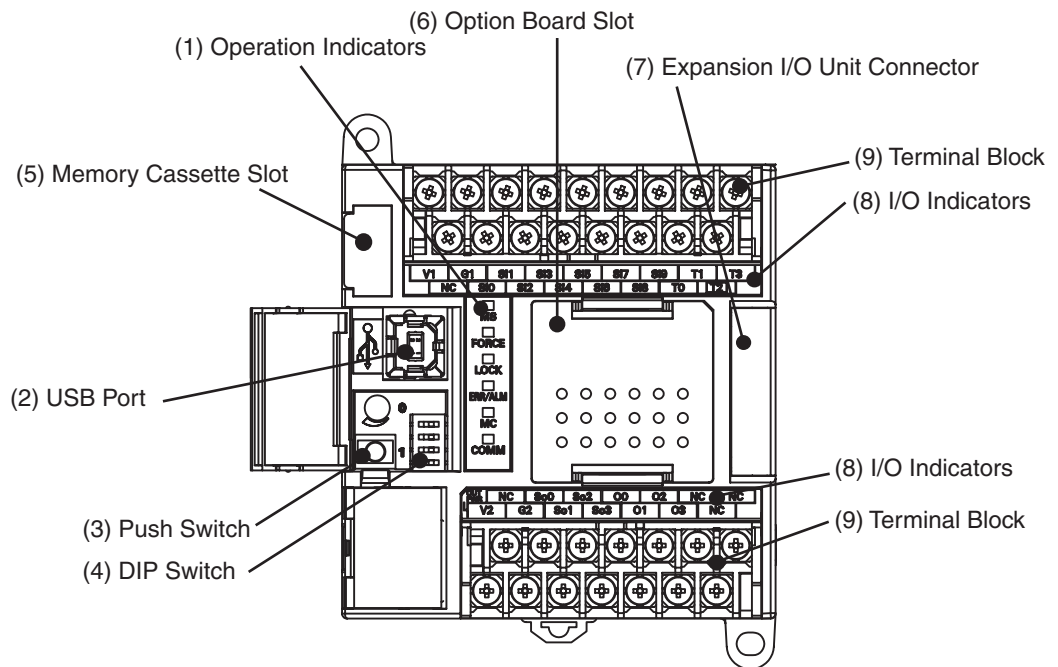

##### G9SP-N10D

##### G9SP-N20S

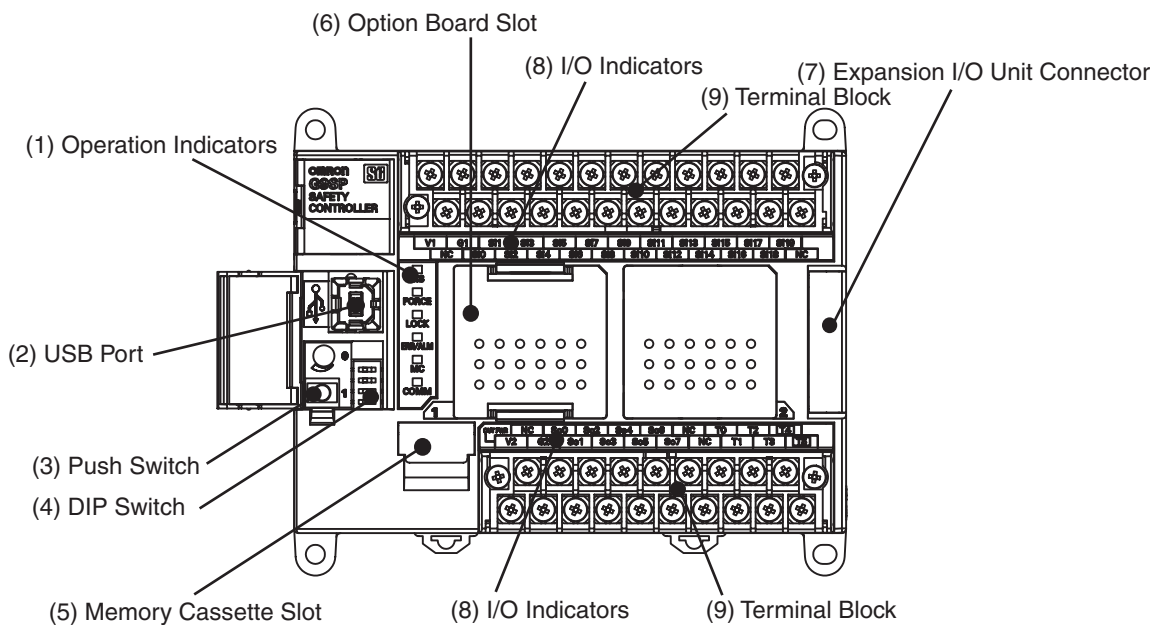



No.	Name	Function																				
1	Operation Indicators	These indicators can be used to check the operating status of the G9SP-series Controller.																				
2	USB Port	Connect a USB cable to this port to connect to a computer to set up and monitor the G9SP-series Controller from the G9SP Configurator. A commercially available USB cable can be used. The G9SP-series Controller end of the USB cable must be a B-type male connector. <i>5-2-2 Installing the USB Driver</i>																				
3	Push Switch	This switch is used for the following operations. 1. Backing up data to a Memory Cassette and restoring data from a Memory Cassette 2. Displaying the current configuration ID on the I/O indicators <i>SECTION 11 Backup and Restore Data Using Memory Cassette</i>																				
4	DIP Switch	The DIP switch is used to back up data to a Memory Cassette. <table border="1" data-bbox="518 627 1407 974"> <thead> <tr> <th>No.</th> <th>Name</th> <th>Description</th> <th>Default</th> </tr> </thead> <tbody> <tr> <td>Pin 1</td> <td>Do not use.</td> <td>Leave set to OFF</td> <td>OFF</td> </tr> <tr> <td>Pin 2</td> <td>Do not use.</td> <td>Leave set to OFF</td> <td>OFF</td> </tr> <tr> <td>Pin 3</td> <td>Do not use.</td> <td>Leave set to OFF</td> <td>OFF</td> </tr> <tr> <td>Pin 4</td> <td>Backup from G9SP-series Controller to Memory Cassette</td> <td>If the G9SP-series Controller is started while this pin is ON, the data will be backed up from the G9SP-series Controller to the Memory Cassette (MC). Leave this pin turned OFF during normal operation.</td> <td>OFF</td> </tr> </tbody> </table>	No.	Name	Description	Default	Pin 1	Do not use.	Leave set to OFF	OFF	Pin 2	Do not use.	Leave set to OFF	OFF	Pin 3	Do not use.	Leave set to OFF	OFF	Pin 4	Backup from G9SP-series Controller to Memory Cassette	If the G9SP-series Controller is started while this pin is ON, the data will be backed up from the G9SP-series Controller to the Memory Cassette (MC). Leave this pin turned OFF during normal operation.	OFF
No.	Name	Description	Default																			
Pin 1	Do not use.	Leave set to OFF	OFF																			
Pin 2	Do not use.	Leave set to OFF	OFF																			
Pin 3	Do not use.	Leave set to OFF	OFF																			
Pin 4	Backup from G9SP-series Controller to Memory Cassette	If the G9SP-series Controller is started while this pin is ON, the data will be backed up from the G9SP-series Controller to the Memory Cassette (MC). Leave this pin turned OFF during normal operation.	OFF																			
5	Memory Cassette Slot	The Memory Cassette is mounted in this slot. A slot cover is attached when the G9SP-series Controller is shipped from the factory. <i>1-1-2 Basic System and Configuration Devices</i> <i>2-3 Option Units</i> <i>SECTION 11 Backup and Restore Data Using Memory Cassette</i>																				
6	Option Board Slot	One Option Board can be mounted in this slot. <i>1-1-2 Basic System and Configuration Devices</i> <i>2-3 Option Units</i>																				
7	Expansion I/O Unit Connector	Up to two CP-series Expansion I/O Units can be connected. <i>1-1-2 Basic System and Configuration Devices</i> <i>2-2 Expansion I/O Units</i>																				
8	I/O Indicators	These indicators show the status of the built-in I/O terminals.																				
9	Terminal Block	Connect the power supply and I/O devices to the terminal block.																				



### Precautions for Correct Use

The USB cable must be 3 m or less in length.

**Operation Indicators**

This section describes the operation indicators that are provided on the G9SP-series Controller. Refer to sections on individual functions for details.

● : OFF   ◐ : Flashing   ◑ : ON

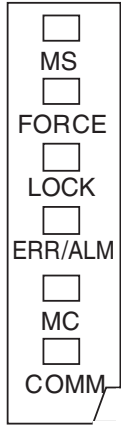

Indicator	Color	Status	Description
MS (Module Status)	Green	◑	Operating (RUN Mode)
		◐	Idle (IDLE Mode)
	Red	◑	Critical fault status (fatal error)
		◐	Abort status (non-fatal error, such as connection of an unsupported Unit)
	Green/Red	◐	The G9SP-series Controller is being initialized or is waiting for configuration.
	---	●	Power is not being supplied to the internal circuits or a Memory Cassette operation is in progress.
	Reference	SECTION 9 Operation and Operating Modes	
FORCE (force-set/reset status)	Yellow	◑	Force-setting/resetting is enabled (Force Mode).
		●	Force Mode is not being used or a Memory Cassette operation is in progress.
	Reference	SECTION 9 Operation and Operating Modes 10-3 Debugging in Force Mode	
LOCK (configuration lock)	Yellow	◑	The configuration is valid and locked.
		◐	The configuration is valid and unlocked.
		●	There is no valid configuration or a Memory Cassette operation is in progress.
	Reference	9-4 Changing the Configuration Data	
ERR/ALM (error status)	Red	◑	A fatal error has occurred.
		◐	A non-fatal error has occurred.
		●	Operation is normal.
	Reference	SECTION 13 Troubleshooting	
MC (Memory Cassette)	Yellow	◑	One of the following Memory Cassette operations has been completed. 1. Backing up data to the Memory Cassette 2. Restoring data from the Memory Cassette This indicator lights yellow when the operation ends normally. If the operation ends in an error, this indicator lights yellow and the ERR/ALM indicator lights red.
		◐ 0.5 s	The G9SP-series Controller is waiting to start a Memory Cassette operation.
		◐ 0.25 s	Data is being written to or from the Memory Cassette.
		●	A Memory Cassette operation is not being performed.
	Reference	SECTION 11 Backup and Restore Data Using Memory Cassette	
COMM (USB communications)	Yellow	◐	USB communications are in progress (data is being sent or received).
		●	USB communications are not in progress.



**Precautions for Safe Use**

If the MC indicator is flashing at 0.25-s intervals, it indicates that the Memory Cassette is being accessed (read or written).

Do not turn OFF the internal circuit power supply to the G9SP-series Controller or remove the Memory Cassette until the indicator stops flashing. If the power supply is turned OFF while data is being accessed, data in the G9SP-series Controller may be corrupted or lost.

**I/O Indicators**

This section describes the I/O indicators that are provided on the G9SP-series Controller.

Self-diagnosis is performed to detect circuit failures and other circuit problems for Safety Input and Safety Output terminals. If errors are detected in this self-diagnosis, the terminal where the error occurred will be shown by a red indicator.

● : OFF ◐ : Flashing ○ : ON

Indicator name	Color	Status	Meaning
OUT PWR (Output Power)	Green	○	The output power supply is normal.
		●	<ul style="list-style-type: none"> <li>The output power supply is not being supplied.</li> <li>The Controller is being initialized.</li> <li>Configuring Mode</li> <li>A fatal error has occurred.</li> </ul>
Si0 to Sin n: Terminal number of Safety Input terminal	Yellow	○	The input signal is ON.
	Red	○	<ul style="list-style-type: none"> <li>An error was detected in an input circuit.</li> <li>A discrepancy error (input data mismatch) was detected for Dual Channel Mode settings.</li> <li>If an error is detected for a Memory Cassette operation, the terminal number indicator that corresponds to the error code will light.</li> </ul>
		◐	An error was detected in other terminal in Dual Channel Mode (with no error for this input).
	---	●	<ul style="list-style-type: none"> <li>The input signal is OFF.</li> <li>Initialization is in progress.</li> <li>Waiting for configuration.</li> <li>A fatal error occurred.</li> </ul>
So0 to Son n: Terminal number of Safety Output terminal	Yellow	○	The output signal is ON.
	Red	○	<ul style="list-style-type: none"> <li>An error was detected in an output circuit.</li> <li>A dual channel violation (output data mismatch) was detected in Dual Channel Mode.</li> </ul>
		◐	An error was detected in other terminal in Dual Channel Mode (with no error for this input).
	---	●	The output signal is OFF.
O0 to On n: Terminal number of Standard Output terminal	Yellow	○	The output signal is ON.
		●	The output signal is OFF.

**⚠ WARNING** Serious injury may possibly occur due to loss of required safety functions. Do not use indicators on the G9SP-series Controller for safety operations.

## 2-1-2 Terminal Arrangements

### G9SP-N10S

Top (17 pins)	V1	G1	Si1	Si3	Si5	Si7	Si9	T1	T3
	NC	Si0	Si2	Si4	Si6	Si8	T0	T2	

Bottom (14 pins)	NC	So0	So2	O0	O2	NC	NC
	V2	G2	So1	So3	O1	O3	NC

### G9SP-N10D

Top (24 pins)	V1	G1	Si1	Si3	Si5	Si7	Si9	NC	NC	T1	T3	T5
	NC	Si0	Si2	Si4	Si6	Si8	NC	NC	T0	T2	T4	NC

Bottom (19 pins)	NC	So0	So2	So4	So6	So8	So10	So12	So14	
	V2	G2	So1	So3	So5	So7	So9	So11	So13	So15

### G9SP-N20S

Top (24 pins)	V1	G1	Si1	Si3	Si5	Si7	Si9	Si11	Si13	Si15	Si17	Si19
	NC	Si0	Si2	Si4	Si6	Si8	Si10	Si12	Si14	Si16	Si18	NC

Bottom (19 pins)	NC	So0	So2	So4	So6	NC	T0	T2	T4	
	V2	G2	So1	So3	So5	So7	NC	T1	T3	T5

### Internal Circuits and Wiring Diagram

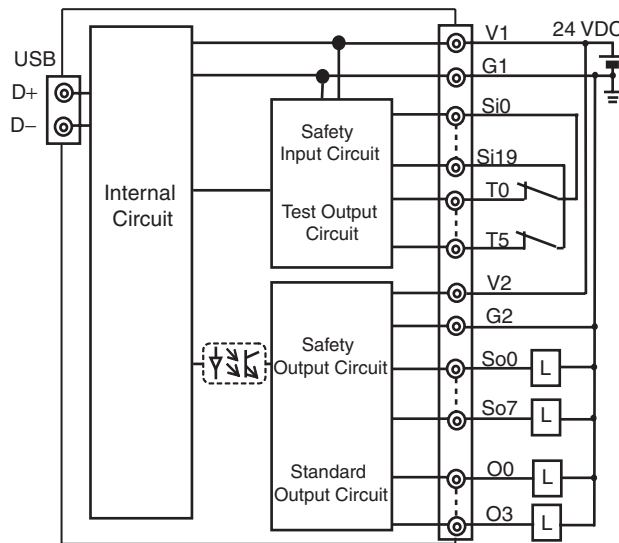

### Terminals

Terminals	Function
V1/G1	Power supply terminals for internal and input circuits (24 VDC).
V2/G2	Power supply terminals for output circuits (24 VDC).
NC	Not used (Do not connect)
Si0 to Si19	Safety Input terminals
T0 to T5	Test Output terminals
So0 to So15	Safety Output terminals
O0 to O3	Standard Output terminals

### 2-1-3 General Specifications

Item	Specification
Power supply voltage (V1, V2)	24 VDC (20.4 to 26.4 VDC -15%+10%)
Current consumption*1	400 mA (V1: 300 mA, V2: 100 mA) (N10S) 500 mA (V1: 300 mA, V2: 200 mA) (N10D) 500 mA (V1: 400 mA, V2: 100 mA) (N20S)
Insulation class	Class III (SELV)
Overvoltage category	II
Noise immunity	Compliant with IEC 61131-2
Vibration resistance	5 to 8.4 Hz: 3.5 mm, 8.4 to 150 Hz: 9.8 m/s <sup>2</sup>
Shock resistance	147 m/s <sup>2</sup> : 11ms
Mounting	DIN Track (IEC 60715 TH35-7.5 / TH35-15) or M4 screws
Ambient operating temperature	0 to 55°C
Ambient operating humidity	10% to 95% (with no condensation)
Ambient storage temperature	-20 to 75°C
Atmosphere	No corrosive gas
Degree of protection	IP20 except terminal blocks
Terminal screws	M3 self-rising screws

\*1 The current consumption of external devices is not included.

### 2-1-4 I/O Specifications

#### I/O Capacities

Item	G9SP-N10S	G9SP-N10D	G9SP-N20S
Safety Inputs	10 points	10 points	20 points
Safety Outputs	4 points	16 points	8 points
Test Outputs	4 points	6 points	6 points
Standard Outputs	4 points	-	-

#### Safety Input Specifications

Item	Specification
Input type	Sinking inputs (PNP compatible)
Input current	6 mA
ON voltage	11 VDC min. (between inputs and G1)
OFF voltage	5 VDC max. (between inputs and G1)
OFF current	1 mA max.



#### Precautions for Correct Use

Safety devices with semiconductor outputs, such as safety light curtains, sometimes provide a pulse output that is used to detect wiring errors. Observe the following when connecting a safety device with a semiconductor output to a Safety Input terminal on the G9SP-series Controller.

- OFF pulse width when semiconductor output is ON: 700 μs max.

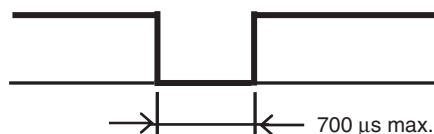

- ON pulse width when semiconductor output is OFF: 30 μs max.

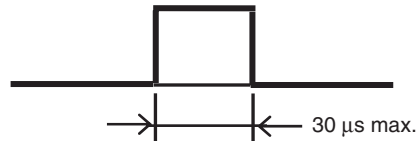

**Test Output Specifications**

Item	Specification	
Output type	Sourcing outputs (PNP)	
Rated output current	G9SP-N10S	T0, T1: 60 mA max. T2: 30 mA max. <sup>*1</sup> T3: 300 mA max. <sup>*2</sup> T0-2 total: 60mA max.
	G9SP-N10D	T0, T1, T2: 60 mA max. T3: 300 mA max. <sup>*2</sup> T4, T5: 30 mA max. <sup>*1</sup> T0-2, T4-5 total: 60mA max.
	G9SP-N20S	T0, T1, T2: 100 mA max. T3: 300 mA max. <sup>*2</sup> T4, T5: 30 mA max. <sup>*1</sup> T0-2, T4-5 total: 120 mA max.
ON residual voltage	1.8 V max. (between test outputs and V1)	
Leakage current	0.1 mA max.	

- \*1 Connection to an OMRON D40A or D40Z Non-Contact Switch is possible.
- \*2 With the Muting Lamp Output (open circuit detection)

**Safety Output Specifications**

Item	Specification
Output type	Sourcing outputs (PNP)
Rated output current	0.8 A max./point 1.6 A max./4 points (N10S or N20S) <sup>*1</sup> 1.2 A max./4 points (N10D) <sup>*2</sup>
ON residual voltage	1.2 V max. (between outputs and V2)
OFF residual voltage	2 V max.
Leakage current	0.1 mA max.

- \*1 Total current for So0 to So3 and So4 to So7.
- \*2 Total current for So0 to So3, So4 to So7, So8 to So11, and So12 to So15.



**Precautions for Safe Use**

When a Safety Output is set as a pulse output, make sure that the connected device does not malfunction for the OFF pulse (pulse width: 640 μs).

**Standard Output Specifications of G9SP-N10S**

Item	Specification
Output type	Sourcing outputs (PNP)
ON residual voltage	1.5 V max. (between outputs and V2)
Rated output current	100mA max.

**Input Wiring**

**Devices with Contact Outputs**

A devices with a contact output, such as an emergency stop pushbutton or safety limit switch, is input to the G9SP-series Controller using a Safety Input terminal (Si) and Test Output terminal (To).

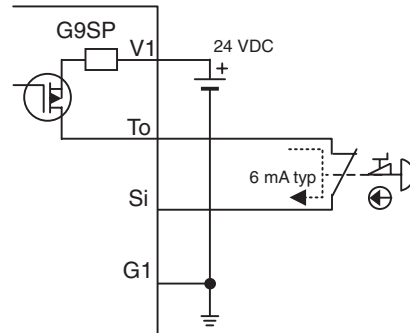

The total length of cable connected to one Test Output must be 600 m or less.

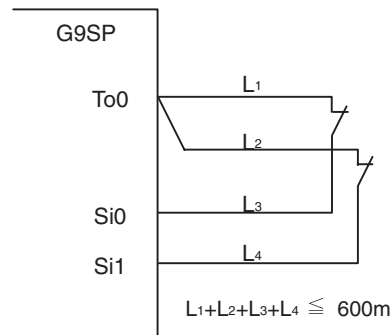

**Devices with PNP Semiconductor Outputs (Current-sourcing Outputs)**

The signal from a device with a PNP semiconductor output, such as a light curtain, is input to a Safety Input terminal (Si). Check the specifications of the connected device for the maximum cable length.

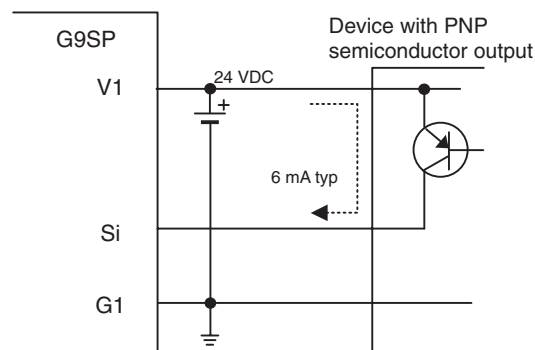

**Output Wiring**

- Refer to the following information when connecting output devices.
- The cable length from an output terminal to the output device must be 100 m or less.

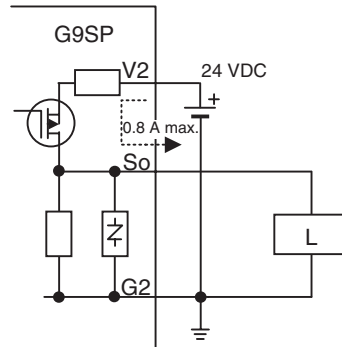

**2-1-5 Safety Inputs**

This section describes the Safety Input functions of the G9SP-series Controller’s Safety I/O functions. The G9SP-series Controller diagnoses the external devices connected to Safety Input terminals.

**Connectable External Devices**

The following table lists the connectable external devices (Safety Devices and Standard Devices).

Type	Examples
Safety Devices with mechanical contacts	Emergency stop switches, safety limit switches, safety switches, enable switches, and 2-hand switches
Safety Devices with semiconductor outputs	Safety curtains and laser scanners
Standard Devices	Limit switches and muting sensors

The following OMRON Safety Devices can be connected directly without special controllers.

Type	Model and category/PL
OMRON Single Beam Safety Sensor	E3ZS and E3FS (Conforms to Type 2 and PLc.)
OMRON Non-contact Switch	D40A (Conforms to Safety Category 3 and PLd.) D40Z (Conforms to Safety Category 4 and PLe.)
OMRON Safety Mat	UM (Conforms to Safety Category 3 and PLd.)



### Setting Safety Input Terminals

A Safety Input terminal on the G9SP-series Controller can be easily set by selecting the connected external device on the G9SP Configurator. (For details, refer to 6-2-2 Hardware Settings.)

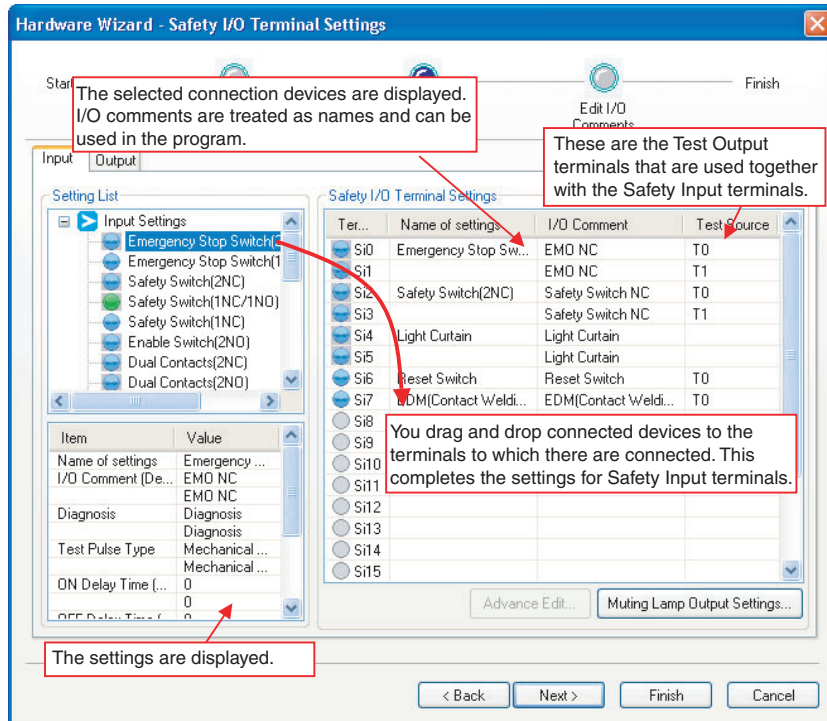

### External Device Connection Examples

#### Connecting Safety Devices with Mechanical Contacts

Connecting an emergency stop switch is described here as an example of connecting Safety Devices with mechanical outputs.

#### Wiring Example

If redundant emergency stop switches are used, a Test Output terminal is also used.

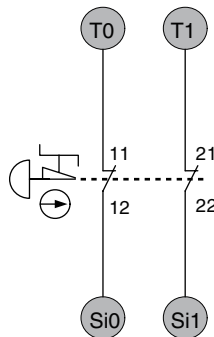

Circuit for Detecting Short Circuits between Input Signals

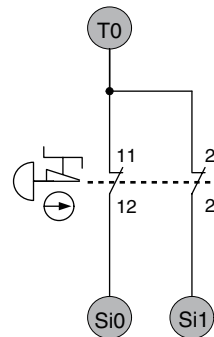

Circuit for Which Detecting Short Circuits between Input Signals Is Not Necessary

#### G9SP Configurator Setting Example

Ter...	Name of settings	I/O Comment	Test Source
Si0	Emergency Stop Sw...	EMO NC	T0
Si1		EMO NC	T1

**Connecting Safety Devices with Semiconductor Outputs**

Connecting a safety light curtain is described here as an example of connecting Safety Devices with semiconductor outputs.

**Wiring Example**

A 24-VDC semiconductor output, such as the OSSD output from the safety light curtain, is input.

Errors in the OSSD output signal line are detected by the externally connected device.

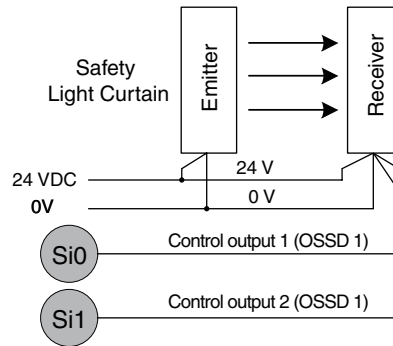

**G9SP Configurator Setting Example**

Ter...	Name of settings	I/O Comment	Test Source
Si0	Light Curtain	Light Curtain	
Si1		Light Curtain	

**Connecting an OMRON E3ZS/E3FS Single Beam Safety Sensor**

This section describes connecting an OMRON E3ZS/E3FS Single Beam Safety Sensor.

**Wiring Example**

The OSSD 24-VDC semiconductor output from the Single Beam Safety Sensor is input.

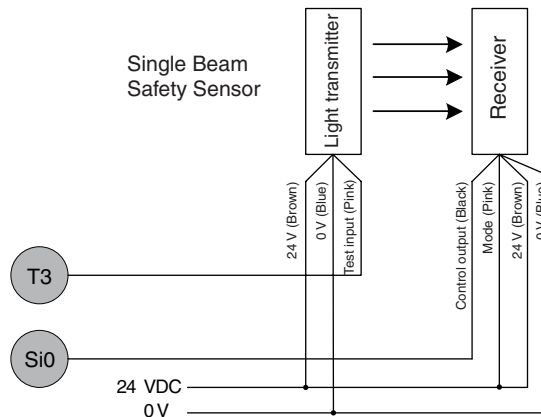

**G9SP Configurator Setting Example**

Ter...	Name of settings	I/O Comment	Test Source
Si0	Single Beam Safety ...	Single Beam	T3



**Precautions for Correct Use**

- Only one E3ZS/E3FS Single Beam Safety Sensor can be connected to the G9SP-series Controller.
- The total wiring length for the E3ZS/E3FS Single Beam Safety Sensor must be 100 m or less.
- The E3ZS/E3FS Single Beam Safety Sensor can be used in a Type 2 or lower, or PLc or lower application. It cannot be used in a Type 3 or higher, or PLd or higher application.

**Connecting an OMRON D40A or D40Z Non-contact Switch**

This section describes connecting an OMRON D40A or D40Z Non-contact Switch.

**Wiring Example**

The non-contact switch output (black line) from the OMRON D40A or D40Z Non-contact Switch is input to a Safety Input terminal. This is a one-line signal. When connecting it to the G9SP-series Controller, branch it, as shown for Si0 and Si1 in the following diagram.

Only one Test Output terminal is used. Connect the Non-Contact Switch input (white line). The inputs for up to 15 Non-Contact Switches can be connected in series to one Test Output terminal.

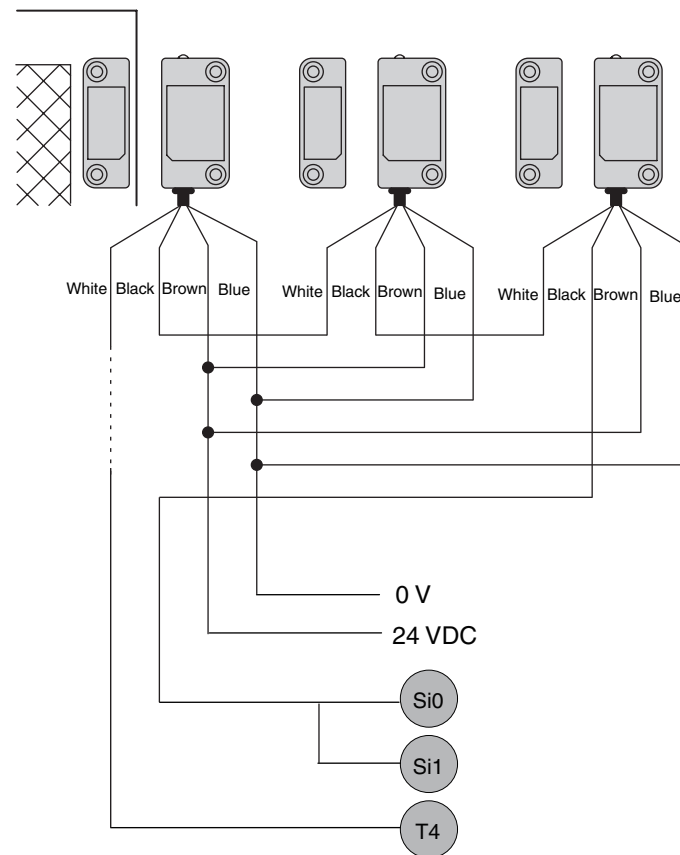

**G9SP Configurator Setting Example**

Ter...	Name of settings	I/O Comment	Test Source
Si0	Non-contact Switch	Non-contact Switch	T4
Si1		Non-contact Switch	T4



**Precautions for Correct Use**

- The maximum number of Switches that can be connected to a G9SP-series Controller is given below.  
 G9SP-N10S: 15 (15 × 1 system)  
 G9SP-N10D/20S: 30 (15 × 2 system)
- The following Test Output terminals must be used to connect to the D40A or D40Z Non-contact Switch. Do not connect any other Test Output terminals.  
 G9SP-N10S: T2  
 G9SP-N10D/20S: T4 and T5
- The total wiring length for the D40A or D40Z Non-contact Switch must be 100 m or less.
- The D40A Non-contact Switch can be used in a Safety Category 3 or lower, or a PLd or lower application. It cannot be used in an Safety Category 4 or PLe application.
- The D40Z Non-contact Switch can be used in a Safety Category 4 or lower, or a PLe or lower application.

**Connecting an OMRON UM Safety Mat**

This section describes connecting an OMRON UM Safety Mat.

**Wiring Example**

A Safety Output from the UM Safety Mat is connected to a Safety Input terminal. Up to 12 UM Safety Mat can be connected in series to one Test Output terminal.

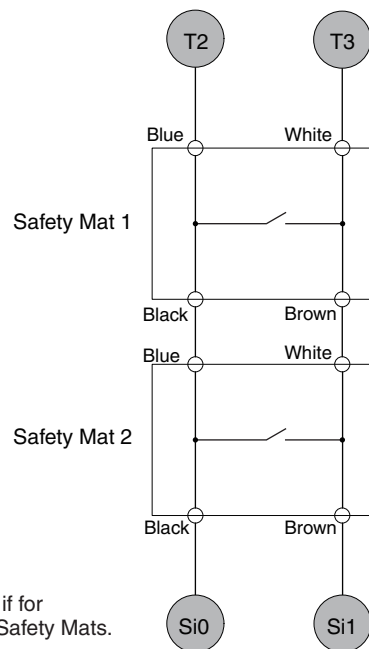

This wiring example is for connecting two UM Safety Mats.

**G9SP Configurator Setting Example**

Ter...	Name of settings	I/O Comment	Test Source
Si0	Safety Mat	Mat	T2
Si1		Mat	T3

**Precautions for Correct Use**

- The maximum number of Mats that can be connected to a Controller is given below.  
12 Mats (12 Mats × 1 system)
- The total wiring length for the UM Safety Mat must be 100 m or less.
- The UM Safety Mat can be used in a Safety Category 3 or lower, or a PLd or lower application. It cannot be used in an Safety Category 4 or PLe application.

### Functions of Safety Input Terminals

This section describes the functions of the Safety Input terminals on the G9SP-series Controller. The following functions are allocated automatically when the external devices to connect are selected from the G9SP Configurator.

The values that are read from the Safety Input terminals are passed to the program only after evaluating them for the Safety Input functions.

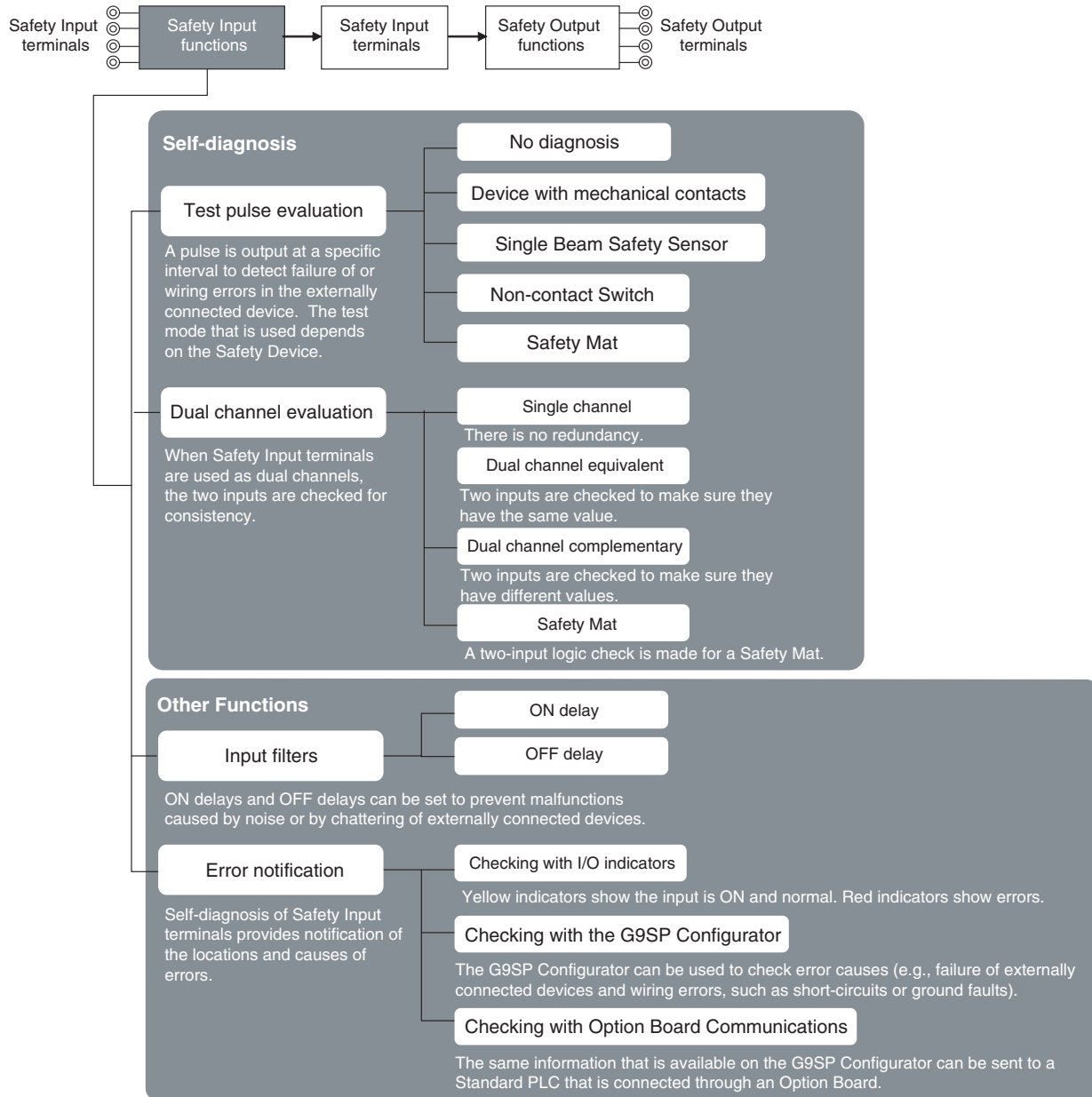

**Test Pulse Evaluation**

A test pulse with a specific period is output on the 24-V power line from a Test Output terminal to detect wiring errors and failure of the externally connected device. The following parameters are also used.

- Diagnosis
- Test source
- Test Mode

Combining Si0 and T0

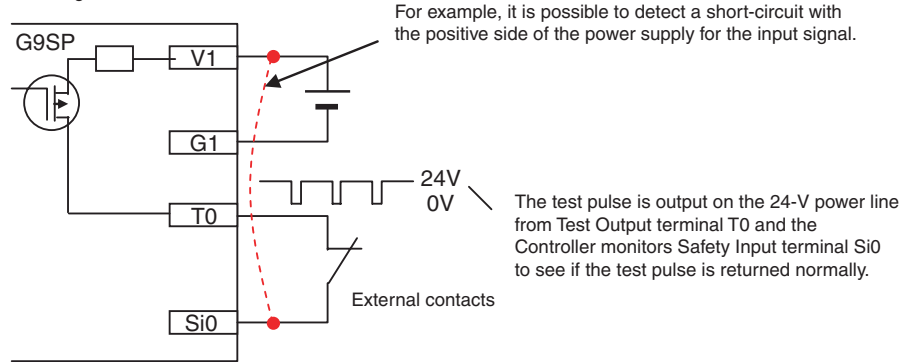

**Diagnosis**

Diagnosis is set according to the type of external device that is connected to the Safety Input terminal.

Setting	Description
No diagnosis	A test pulse from the Test Output terminal is not output for diagnosis. This setting is used for Safety Devices with semiconductor outputs, such as a Safety Light Curtain, and for Standard Devices.
Diagnosis	A test pulse from the Test Output terminal is output for diagnosis. The mode of the Test Output to use as the test source is selected according to the Safety Device that is connected.

**Test Source**

This parameter determines the Test Output terminal to use when the Diagnosis Parameter is set to *Diagnosis*. The Test Output terminal is automatically assigned by the G9SP Configurator, but it can be changed to any Test Output terminal.



**Precautions for Correct Use**

The following Test Output terminals must be used to connect to the D40A or D40Z Non-contact Switch. Do not connect any other Test Output terminals.

- G9SP-N10S: T2
- G9SP-N10D/20S: T4 and T5

## Test Mode

When the Diagnosis parameter is set to *Diagnosis*, the following setting is required to output a test pulse that is suitable for the external device.

Setting	Function
Mechanical contacts	The test pulse is connected to a device with mechanical contacts. The Safety Input terminal's Test Output signal (pulse output) is input through the mechanical contact device. The following can be detected: Contact of the input signal line with the positive side of the power supply line, ground faults, and short-circuits to the other input signal lines.
Single Beam Safety Sensor	An OMRON E3ZS/E3FS Single Beam Safety Sensor is connected. A test signal for Single Beam Safety Sensor diagnosis is output.
Non-contact Switch	An OMRON D40A or D40Z Non-contact Switch is connected. Test signals for the D40A or D40Z will be output.
Safety Mat	An OMRON UM Safety Mat is connected. Test signals for diagnosing the Safety Mat will be output.

## Dual Channel Evaluation

Input safety terminals can be used as dual channels (one pair) for the G9SP-series Controller. This function evaluates the data for two inputs to check for discrepancy. The following parameters are also used.

- Single/Dual Setting
- Discrepancy Time

### Single/Dual Setting

Setting	Description
Single Channel	The Safety Input terminals are used as independent Safety Input terminals.
Dual Channel Equivalent	The Safety Input terminals are used as a dual channel equivalent pair.
Dual Channel Complementary	The Safety Input terminals are used as a dual channel complementary pair.
Safety Mat	The Safety Input terminals are used as Safety Mat Safety Input pair.

### Discrepancy Time

For two inputs set in a Dual Channel Mode, the time is monitored from a change in the value of one input to a change in the value of the other input. An error occurs if the value of the other input does not change within the set discrepancy time.

The discrepancy time can be set in increments of 10 ms between 0 (disabled) and 65,530 ms.

The discrepancy time cannot be set in Single Channel Mode.

### Relationship between Input Tags

The data that is input to Safety Input terminals is evaluated as shown in the following table. The results of this evaluation are reflected in the input tags that are used in the program.

Single/dual	Input signal from Safety Input terminal	Value after evaluation	Meaning of status
	Si (n)	Si (n+1)	
Single Channel	0	0	Inactive (OFF)
	1	1	Active (ON)



Single/dual	Input signal from Safety Input terminal		Value after evaluation		Meaning of status
	Si (n)	Si (n+1)	Si (n)	Si (n+1)	
Dual Channel Equivalent	0	0	0	0	Inactive (OFF)
	0	1	0	0	Discrepant status
	1	0	0	0	Discrepant status
	1	1	1	1	Active (ON)
Dual Channel Complementary	0	0	0	1	Discrepant status
	0	1	0	1	Inactive (OFF)
	1	0	1	0	Active (ON)
	1	1	0	1	Discrepant status

n = Even number

Single/dual	Status of Safety Mat	Value after evaluation		Meaning of status
		Si (n)	Si (n+1)	
Safety Mat	No load	1	1	Active (ON)
	With load	0	0	Inactive (OFF)

■ Operation for Dual Channel Equivalent Inputs: Normal Operation

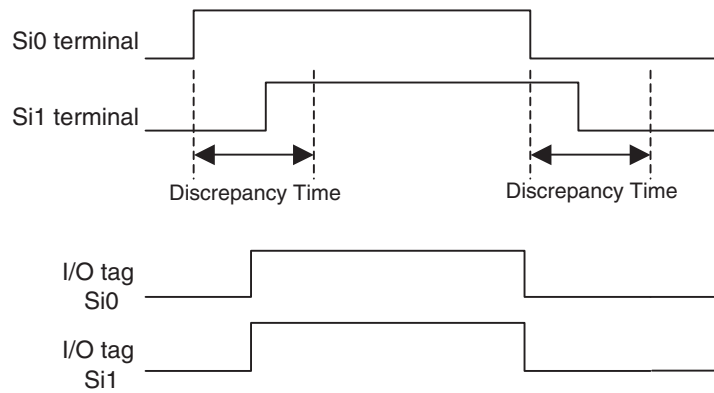

■ Operation for Dual Channel Equivalent Inputs: Discrepancy Error

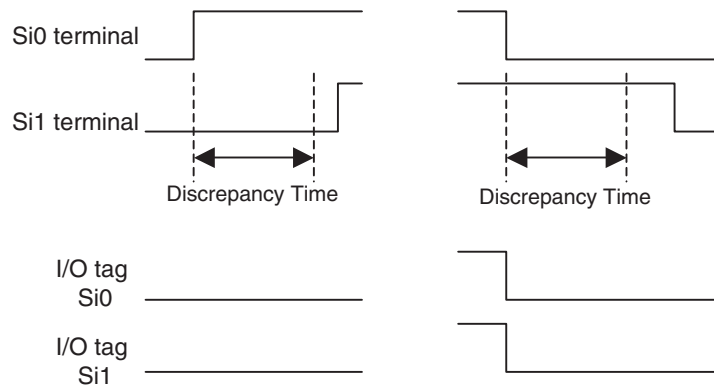

## Input Filters

ON delays and OFF delays can be set to prevent malfunctions caused by noise or by chattering of externally connected devices.

ON delays and OFF delays can be set for each terminal from 0 to 1,000 ms. The effect of chattering from external devices can be reduced more by increasing the delay time, but this will slow the response to input signals.

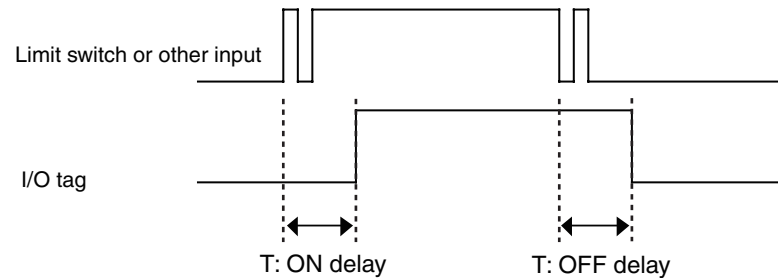

### Precautions for Correct Use

- The ON and OFF delays can be set only as multiples of the cycle time of the G9SP-series Controller. If the cycle time changes, e.g., when the program is changed, the ON and OFF delay times will also change.

Example: Delays for a cycle time of 5 ms: ON delay of  $10 \times 5 \text{ ms} = 50 \text{ ms}$  and OFF delay of  $5 \times 5 = 25 \text{ ms}$

Delays after changing cycle time to 6 ms: ON delay of  $10 \times 6 \text{ ms} = 60 \text{ ms}$  and OFF delay of  $5 \times 6 = 30 \text{ ms}$

- The OFF delay time will affect the safety response performance. Add it to the reaction time. (Refer to *3-2 Reaction Times*.)

## Error Notification

Self-diagnosis of Safety Input terminals provides notification of the locations and causes of errors.

The following three methods can be used to check if errors have been detected.

- Checking with the I/O indicators on the Front of the G9SP-series Controller

The G9SP-series Controller will light or flash the I/O indicators on the front panel if an error is detected in the Safety Input terminals. This lets you identify the terminal where the error was detected. Refer to *2-1-1 Part Names and Indicators* for information on the indicator patterns.

- Checking with the G9SP Configurator

If the G9SP Configurator is connected online when an error has been detected in the Safety Input terminals, the terminal where the error was detected and the cause of the error can be checked. Refer to *10-1 Monitoring Devices* for the procedures and displays for using the G9SP Configurator.

- Checking with Option Board Communications

Option Board communications can be used when an error has been detected in the Safety Input terminals to monitor the error location and error cause from a Standard PLC. Refer to *SECTION 7 Communications with a Standard PLC Using an Option Board* for detailed specifications on communications procedures and data for Option Boards.

**Operation at Error Detection**

When the G9SP-series Controller detects an error in the Safety Input terminals, the following operations will take place.

- The Safety Input evaluation data that is passed to the program is made inactive.
- The ERR indicator will flash red and the I/O indicator of the Safety Input terminal where the error was detected will light red.  
If Dual Channel Mode is being used, the I/O indicator for the other terminal will flash red.
- The error will be recorded in the error log.
- Operation will continue.

**Resetting Errors**

All the following conditions must be met to reset errors that occur in the Safety Inputs.

- The cause of the error must be removed.
- An inactive signal must be input (e.g., pressing the emergency stop button or opening a door).

## 2-1-6 Safety Outputs

This section describes the Safety Output functions of the G9SP-series Controllers Safety I/O functions. The G9SP-series Controller diagnoses the external devices connected to Safety Output terminals.

### Devices That Can Be Connected

The following table lists the devices that can be connected.

Type	Example
Safety Devices with PNP output contacts	Safety relays and contactors

### Setting Safety Output Terminals

A Safety Output terminal on the G9SP-series Controller can be easily set by selecting the connected external device on the G9SP Configurator. (For details, refer to 6-2-2 Hardware Settings.)

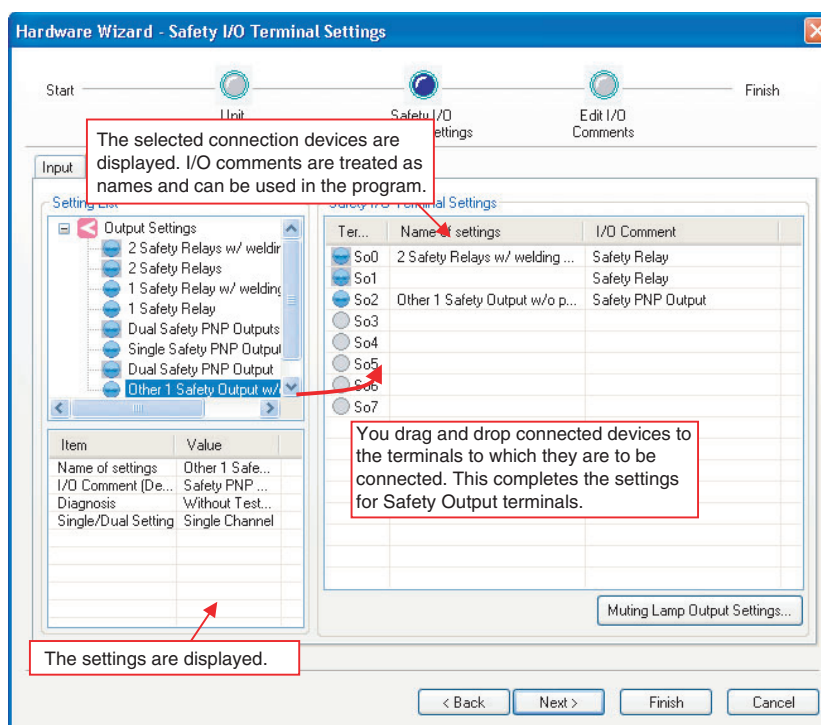

**External Device Connection Examples**

Refer to the following information when connecting output devices.

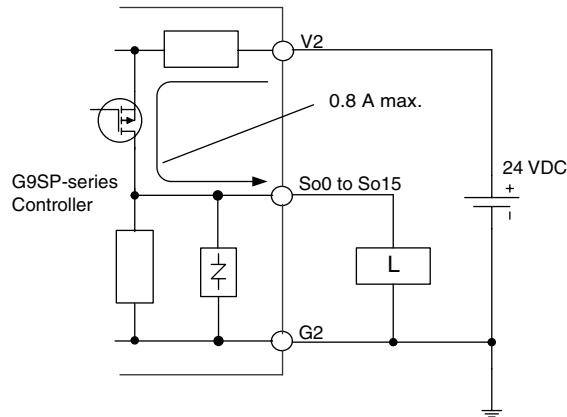

**⚠ WARNING** Serious injury may possibly occur due to breakdown of safety outputs or test outputs. Do not connect loads beyond the rated values to the safety outputs and test outputs.

**⚠ WARNING** Serious injury may possibly occur due to loss of required safety functions. Wire the G9SP-series Controller properly so that the 24VDC line does NOT touch the outputs accidentally or unintentionally.

**⚠ WARNING** Serious injury may possibly occur due to loss of required safety functions. Ground the 0V line of the power supply for external output devices so that the devices do NOT turn ON when the safety output line or the test output line is grounded.

**⚠ WARNING** Serious injury may possibly occur due to loss of required safety functions. Use appropriate components or devices according to the requirements given in the following table.

Control device	Requirements
Contactors	Use a contactor with a forcibly guided mechanism. For feedback signals to detect contactor failure, use a device with NC contacts. For feedback, use a device with NC contacts capable of switching micro-loads of 6 mA at 24 VDC.
Other control device	Verify whether the device is appropriate for the required safety category.



**Precautions for Correct Use**

- Be sure to separate I/O cables from high-voltage and power lines.
- The cable length from an output terminal to the output device must be 100 m or less.

## Functions of Safety Output Terminals

This section describes the functions of the Safety Output terminals on the G9SP-series Controller. The following functions are allocated automatically when the external devices to connect are selected from the G9SP Configurator.

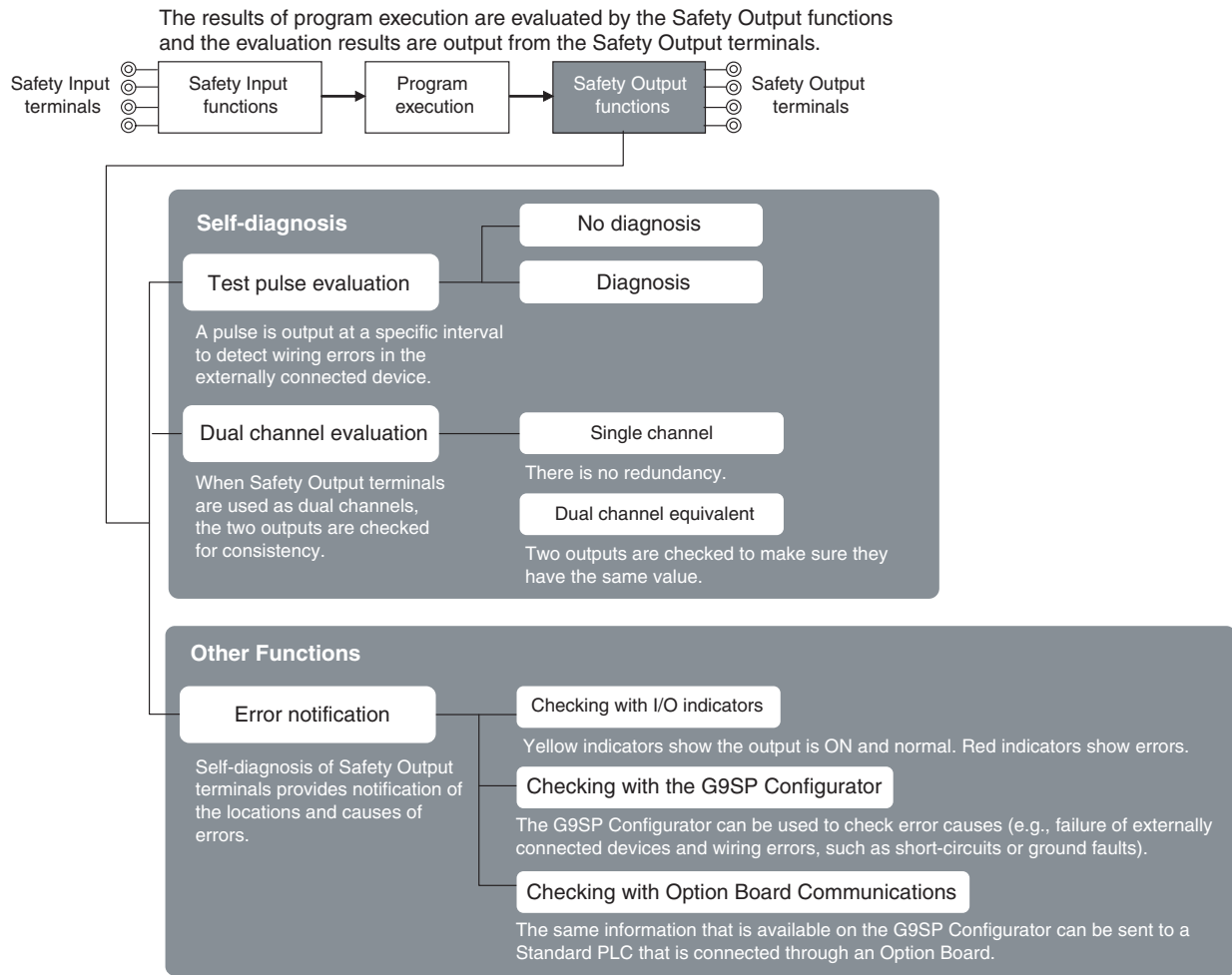

### Test Pulse Evaluation

A test pulse with a specific period is output on the 24-V power line from a Safety Output Terminal to detect wiring errors. This function is achieved with the following parameter.

- Diagnosis

## Diagnosis

The parameter determines whether test pulse evaluation is used. The errors that can be detected are determined by the setting of this parameter.

Channel mode	Description of operation	Fault Mode						
		Contact with positive side of power line		Ground faults		Short circuits in output wiring		
		Output ON	Output OFF	Output ON	Output OFF	Short circuit when both outputs are ON	Short circuit when both outputs are OFF	Short circuit when one output is ON and the other is OFF
No Diagnosis	Test pulses are not output when the output is ON.	Not detectable	Detectable	Detectable	Not detectable	Not detectable	Not detectable	Not detectable
Diagnosis	Test pulses are output when the output is ON.	Detectable	Detectable	Detectable	Not detectable	Detectable	Not detectable	Detectable



### Precautions for Correct Use

- Disconnections can be detected by using the EDM function block.
- If the parameter is set to *Diagnosis*, OFF pulse signals with a pulse width of 640 μs will be output when the Safety Output is ON to diagnose the output circuit. Check the input response time of the connected control device to make sure it will not malfunction due to these OFF pulses.

## Dual Channel Mode Setting

The G9SP-series Controller can use Safety Outputs in a Dual Channel Mode. The following actions will be performed if a Dual Channel Mode is set:

- An error will occur if the two outputs from the user program are not equivalent.
- If an error is detected in either of the two output terminals, the outputs to the external devices are both turned OFF.

This function is achieved with the following parameter.

- Single/Dual Setting

### Single/Dual Setting

Setting	Description
Single channel	The Safety Output terminals are used as independent Safety Input terminals.
Dual channel equivalent	The pair of Safety Output terminals are used as Dual Channel outputs. The outputs will turn ON if the paired Safety Outputs are both normal.

### Relationship between Output Tags

The data of the output tags that are used in the program are output to the Safety Output terminals according to the single/dual channel setting as shown below.

Single/dual	Output tag value		Output signal from the Safety Output terminal		Meaning of status
	So (x)		So (x)		
Single Channel	0		0		Inactive (OFF)
	1		1		Active (ON)

Single/dual	Output tag value		Output signal from the Safety Output terminal		Meaning of status
	So (n)	So (n+1)	So (n)	So (n+1)	
Dual channel equivalent	0	0	0 (OFF)	0 (OFF)	Inactive (OFF)
	0	1	0 (OFF)	0 (OFF)	Output data error (OFF)
	1	0	0 (OFF)	0 (OFF)	Output data error (OFF)
	1	1	1 (ON)	1 (ON)	Active (ON)

n = Even number

### Troubleshooting

Self-diagnosis of Safety Output terminals provides notification of the locations and causes of errors. The following three methods can be used to check if errors have been detected.

#### ■ Checking with the I/O indicators on the Front of the G9SP-series Controller

The G9SP-series Controller will light or flash the I/O indicators on the front panel if an error is detected in the Safety Output terminals. This lets you identify the terminal where the error was detected. Refer to *2-1-1 Part Names and Indicators* for information on the indicator patterns.

#### ■ Checking with the G9SP Configurator

If the G9SP Configurator is connected online when an error has been detected in the Safety Output terminals, the terminal where the error was detected and the cause of the error can be checked. Refer to *10-1 Monitoring Devices* for the procedures and displays for using the G9SP Configurator.

#### ■ Checking with Option Board Communications

Option Board communications can be used when an error has been detected in the Safety Output terminals to monitor the error location and error cause from a Standard PLC. Refer to *SECTION 7 Communications with a Standard PLC Using an Option Board* for detailed specifications on communications procedures and data for Option Boards.



**Operation at Error Detection**

The G9SP-series Controller performs the following actions if an error is detected in the Safety Output terminals:

- The outputs to external devices are immediately made inactive regardless of the status of the user program.
- The ERR indicator will flash red and the I/O indicator of the Safety Output terminal where the error was detected will light red. In Dual Channel Mode, indicator of the other output flashes red.
- The error is recorded in the error log.
- Operation continues.

**Resetting Errors**

All the following conditions must be met to reset errors that occur in the Safety Outputs.

- The cause of the error must be removed.
- The output signal from the user application for the corresponding Safety Output terminal to the output tag must be made inactive.

## 2-2 Expansion I/O Units

This section provides the names of Expansion I/O Unit parts, I/O specifications, and terminal arrangements. Refer to *4-1 Installation* and *4-2 Wiring* for dimensions and weights.

### 2-2-1 Part Names and Indicators

#### Part Names and Functions

##### Standard I/O Units with 20 I/O Points (CP1W-20EDT/20EDT1)

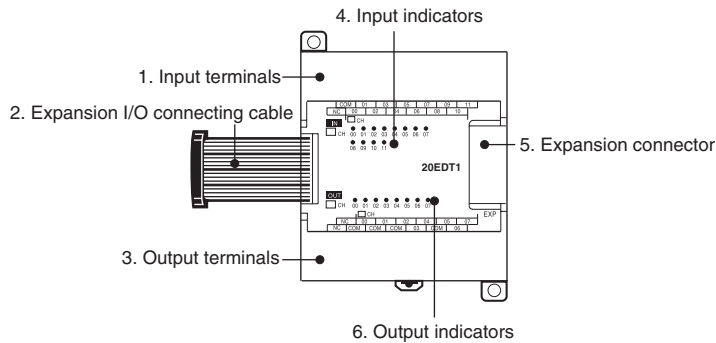

##### Standard Output Units with 32 I/O Points (CP1W-32ET/ET1)

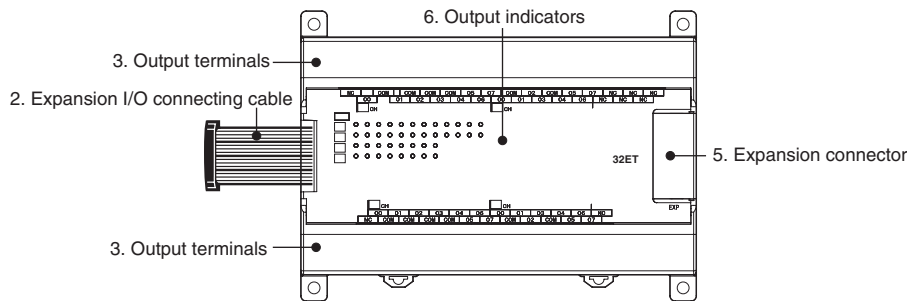

Number	Name	Function
1	Input terminals	Used to connect input devices.
2	Expansion I/O connecting cable	This cable is used to connect the adjacent Units, including the G9SP-series Controller, Expansion I/O Units, or Expansion Units. For extended connections or vertical arrangements, use the CP1W-CN811 I/O Connecting Cable (length: 800 mm).
3	Output terminals	Used to connect output devices.
4	Input indicators	Input status is displayed. An indicator will be ON when the input is ON.
5	Expansion connector	CP-series Expansion I/O Units can be connected. <i>1-1-2 Basic System and Configuration Devices</i> <i>2-2 Expansion I/O Units</i>
6	Output indicators	Output status is displayed. An indicator will be ON when the output is ON.

I/O Indicators

● : OFF ☉ : ON

Indicator	Color	Status	Description
IN0 to INn n: Terminal number (Standard Input terminals)	Yellow	☉	The input signal is ON.
	---	●	The input signal is OFF.
OUT0 to OUTn n: Terminal number (Standard Output terminals)	Yellow	☉	The output signal is ON.
		●	The output signal is OFF.

**⚠ WARNING** Serious injury may possibly occur due to loss of required safety functions. Do not use the G9SP-series Controller's indicators for safety operations.

2-2-2 Terminal Arrangements

Standard I/O Units with 20 I/O Points (CP1W-20EDT/20EDT1)

■ Input (Unit Upper Terminal Block)

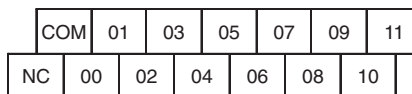

COM: Common terminal  
00 to 11: Input terminal  
NC: No connection

■ Output (Unit Lower Terminal Block)

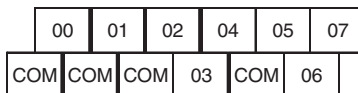

COM: Common terminal  
00 to 07: Output terminal

Standard Output Units with 32 I/O Points (CP1W-32ET/32ET1)

■ Output (Unit Upper Terminal Block)

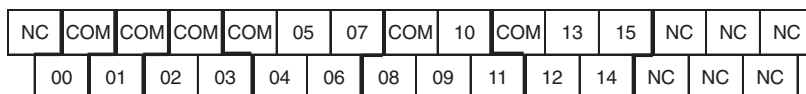

COM: Common terminal  
00 to 15: Output terminal  
NC: No connection

■ Output (Unit Lower Terminal Block)



COM: Common terminal  
16 to 31: Output terminal  
NC: No connection

### 2-2-3 I/O Specifications

This section describes the I/O specifications of Expansion I/O Units.

#### Input Specifications (CP1W-20EDT/20EDT1)

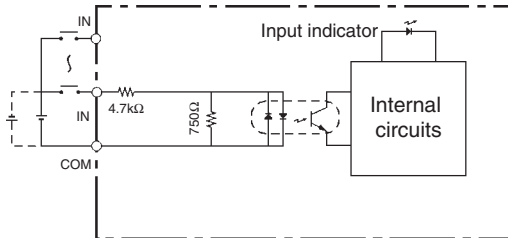
Item	Specification
Input voltage	24 VDC, +10%, -15%
Input impedance	4.7 k $\Omega$
Input current	5 mA typical
ON voltage	14.4 VDC min.
OFF voltage	5.0 VDC max.
ON response time	1 ms max.*
OFF response time	1 ms max.*
Circuit configuration	

\* The response time is the delay caused by hardware.



#### Precautions for Safe Use

Do not apply voltage in excess of the rated voltage to the input terminal.

**Output Specifications for Transistor Outputs (Sinking or Sourcing)**

Item	Specification	
	CP1W-20EDT/20EDT1	CP1W-32ET/32ET1
Maximum switching capacity*1	24 VDC +10%/-5% 0.3 A/output	4.5 to 30 VDC 0.3 A/output
	0.9 A/common 1.8 A/Unit	0.9 A/common 7.2 A/Unit
Leakage current	0.1 mA max.	0.1 mA max.
Residual voltage	1.5 V max.	1.5 V max.
ON response time	0.1 ms max.	0.1 ms max.
OFF response time	1 ms max. At 24 VDC +10%/ -5%, 5 to 300 mA	1 ms max. At 24 VDC +10%/ -5%, 5 to 300 mA
Maximum number of simultaneously ON outputs	8 points (100% load)	24 points (75% load)
Fuse*2	1 fuse/common	
Circuit configuration	<p>Sinking Outputs (CP1W-20EDT and CP1W-32ET)</p>	<p>Sourcing Outputs (CP1W-20EDT1 and CP1W-32ET1)</p>

\*1 If the ambient temperature is maintained below 50°C, up to 0.9 A/common can be used.

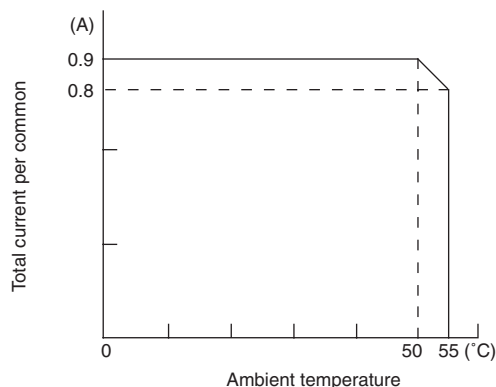

\*2 The fuse cannot be replaced by the user. Replace the Unit if the fuse breaks due to a short-circuit or overcurrent.



**Precautions for Safe Use**

Do not connect a load to an output terminal or apply a voltage in excess of the maximum switching capacity.

**2-2-4 Current Consumption**

Unit		Model	Current consumption	
			5 VDC	24 VDC
Expansion I/O Units	20 I/O points Inputs: 12 Outputs: 8	CP1W-20EDT	0.130 A	---
		CP1W-20EDT1		
	32 output points	CP1W-32ET	0.113 A	---
		CP1W-32ET1		

## 2-3 Option Units

The section describes the part names, connector arrangement, communications specifications, and other information on Option Units.

Refer to 4-1 *Installation* and 4-2 *Wiring* for dimensions and weights.

### 2-3-1 RS-232C Option Board (CP1W-CIF01)

#### Part Names and Connector Arrangement

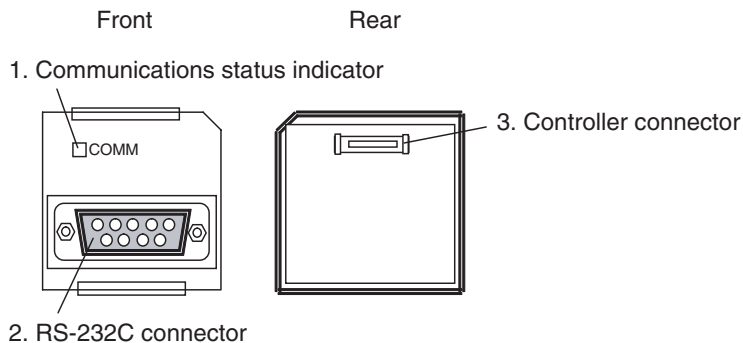

#### Communications Status Indicator

This indicator flashes during serial communications.

#### RS-232C Connector

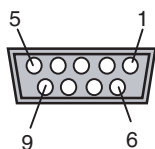

Pin	Abbr.	Signal	Signal direction
1	FG	Frame ground	---
2	SD (TXD)	Send data	Outputs
3	RD (RXD)	Receive data	Inputs
4	RS (RTS)	Request to send	Outputs
5	CS (CTS)	Clear to send	Inputs
6	5 V	Power	---
7	DR (DSR)	Data set ready	Inputs
8	ER (DTR)	Data terminal ready	Outputs
9	SG (0 V)	Signal ground	---
Connector hood	FG	Frame ground	---



#### Precautions for Correct Use

Always turn OFF the power supply to the G9SP-series Controller before mounting or removing Option Boards.

#### Communications Specifications

Only no-protocol communications can be used for RS-232C serial communications of the G9SP-series Controller. Refer to *SECTION 7 Communications with a Standard PLC Using an Option Board* for the communications settings of the connected Standard PLC.

Item		Specification
Connection method		D-sub, 9-pin female connector
Maximum transmission distance		15 m
Communications protocol		No-protocol
Maximum data length		SECTION 7 Communications with a Standard PLC Using an Option Board
Frame format	Start code	0040 hex
	End code	Reception bytes: 256
Communications settings	Baud rate	9,600 bps
	Parameters	Data length: 8 bits Stop bits: 1 bit Parity: Even
Current consumption		Included in the current consumption of the G9SP-series Controller.
Weight		Included in the weight of the G9SP-series Controller.

## 2-3-2 Ethernet Option Board (CP1W-CIF41)

### Part Names and Connector Arrangement

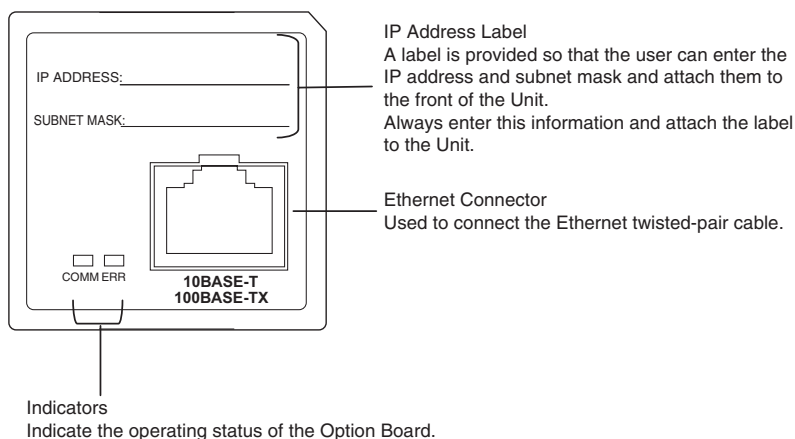

### Communications Status Indicators

LED	Color	Status	Meaning
COMM	Yellow	Not lit	Not sending or receiving data.
		Lit	Sending or receiving data.
ERR	Red	Not lit	The Ethernet Option Board is normal.
		Lit	A fatal communications error has occurred in the Ethernet Option Board.
		Flashing	A non-fatal communications error has occurred in the Ethernet Option Board.



### Precautions for Correct Use

- Only CP1W-CIF41 Ethernet Option Boards with unit version 2.0 or later can be used. If another Option Board is used, the G9SP-series Controller will detect an Unsupported Option Board Error (the MS indicator will flash red).
- Always turn OFF the power supply to the G9SP-series Controller before mounting or removing Option Boards.



## Communications Specifications

Only the UDP/IP protocol can be used for Ethernet communications with the G9SP-series Controller. Refer to *SECTION 7 Communications with a Standard PLC Using an Option Board* for the communications settings of the connected Standard PLC.

### Ethernet Communications Specifications

Item		Specifications		
Type		100Base-TX (can be used as 10Base-T)		
Transmission specifications	Media access method	CSMA/CD		
	Modulation method	Baseband		
	Transmission paths	Star form		
	Baud rate	100 Mbit/s (100Base-TX)	10 Mbit/s (10Base-T)	
		The internal baud rate between the G9SP-series Controller and Ethernet Option Board is 115.2 kbps.		
	Transmission media	Unshielded twisted-pair (UTP) cable Categories: 5, 5e Shielded twisted-pair (STP) cable Categories: 100 Ω at 5, 5e	Unshielded twisted-pair (UTP) cable Categories: 3, 4, 5, 5e Shielded twisted-pair (STP) cable Categories: 100 Ω at 3, 4, 5, 5e	
	Transmission distance	100 m (distance between hub and node)		
Number of cascade connections	No restrictions in using switching hubs			
Current consumption		130 mA max. at 5 V DC		
Vibration resistance		Conforms to JIS 0040. 10 to 57Hz: 0.075-mm amplitude, 57 to 150 Hz: acceleration 9.8 m/s <sup>2</sup> in X, Y, and Z directions for 80 minutes each (sweep time: 8 minutes × 10 sweeps = 80 minutes)		
Shock resistance		Conforms to JIS 0041. 147 m/s <sup>2</sup> , 3 times each in X, Y, and Z directions		
Ambient operating temperature		0 to 55°C		
Ambient humidity		10% to 90% (with no condensation)		
Atmosphere		Must be free of corrosive gas.		
Ambient storage temperature		-20 to 75°C		
Weight		23 g max.		
Dimensions		36.4×36.4×28.2 mm (W×H×D)		

**Note** Communications with OMRON PLCs can be performed using the FINS/UDP protocol.

### 2-3-3 Memory Cassette (CP1W-ME05M)

Refer to *SECTION 11 Backup and Restore Data Using Memory Cassette* for information on using a Memory Cassette with the G9SP-series Controller.



**SECTION 3**  
**Calculating Response Performance**

This section describes the startup time and reaction time of the G9SP-series Controller.

3-1	Startup Time .....	46
3-2	Reaction Times .....	47
3-2-1	Reaction Time Concepts.....	47
3-2-2	Local Input and Local Output Reaction Times.....	47

## 3-1 Startup Time

This section describes the operating flow and startup time of the G9SP-series Controller.

### Operation Flow

The following flowchart shows the operation cycle of the G9SP-series Controller.

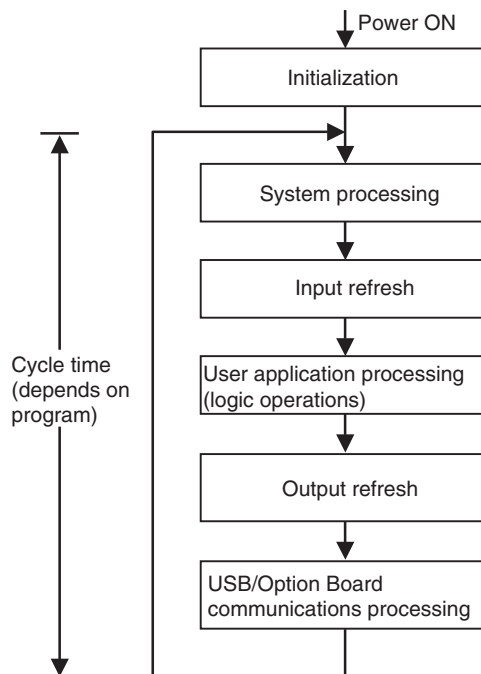

### Initialization Time

The G9SP-series Controller performs initialization when the power supply is turned ON. During initialization, the G9SP-series Controller performs hardware self-diagnosis. The initialization takes up to 3 seconds to be completed from the time that the power is turned ON.

### Time Required to RUN Mode

The G9SP-series Controller will start operation in RUN Mode within 3 seconds after the power supply is turned ON when operation starts automatically. A Standard PLC can monitor the Unit Normal Operating Flag to see if the G9SP-series Controller has started normal operation. The G9SP-series Controller turns ON the Unit Normal Operating Flag when the following conditions have been met.

- RUN Mode has been entered.
- There are no errors in the G9SP-series Controller.

## 3-2 Reaction Times

This section describes how to calculate reaction times (safety response performance) for the G9SP-series Controller.

### 3-2-1 Reaction Time Concepts

#### Reaction Time

The reaction time is the time required to stop machine operation in a worst-case scenario considering the occurrence of faults and failures in the safety chain. The safety chain is the logical connections that are required to achieve a safety function, including the Safety Input device, G9SP-series Controller, and Safety Output device. The reaction time is used to calculate the safety distance.

### 3-2-2 Local Input and Local Output Reaction Times

This section describes the local Safety I/O reaction time for the G9SP-series Controller. When calculating the reaction time of the overall safety chain, calculate separately the reaction times of safety sensor and switches, such as light curtains, and actuators, such as safety relays.

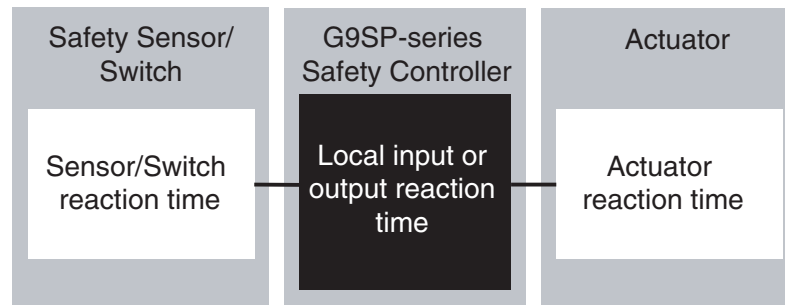

#### Elements for Calculating the Reaction Time

The reaction time for local Safety I/O on the G9SP-series Controller depends on the following conditions. Check the conditions and values before calculating the reaction time.

##### ■ Cycle Time

The cycle time depends on the size and contents of the program.

##### ■ Input OFF Delay Time

If an OFF delay is set for an input, e.g., to prevent chattering, the OFF delay time must be added to the reaction time.



#### **Precautions for Correct Use**

- If the cycle time changes as the result of changes to the program, calculate the reaction time again.
- If an Off-Delay Timer function block is used in the program or if loop-back connections are used, they must also be added to the reaction time.

#### Checking the Safety Input Devices, Cycle Time, and Input OFF Delay Times

The cycle time and input OFF delay times can be checked on the configuration report that is output from the G9SP Configurator.

### Reaction Time Formula

The formula for calculating reaction time for local Safety I/O on the G9SP-series Controller is given below.

$$\text{Local Safety I/O reaction time} = (\text{Cycle time} \times 2) - 2 + \text{Input OFF delay time [ms]}$$

 **WARNING** Serious injury may possibly occur due to loss of required safety functions. Confirm that the calculated reaction times meet the required specifications for all safety chains.



#### **Additional Information**

The safety sensor/switch reaction times are given below for when OMRON Safety Sensors or Switches are connected directly to the G9SP-series Controller.

E3ZS or E3FS Single Beam Safety Sensor: 10 ms

D40A Non-contact Switch: 6 ms + 0.4 ms × Number of connected Switches

D40Z Non-contact Switch: 6 ms + (Cycle time × 2) ms

UM Safety Mat: 10 ms

This section describes how to install and wire the G9SP-series Controller.

4-1	Installation . . . . .	50
4-1-1	Installation Location . . . . .	50
4-1-2	Unit Arrangement . . . . .	52
4-1-3	Installation . . . . .	53
4-1-4	Connecting Expansion I/O Units and Expansion Units . . . . .	54
4-1-5	Mounting Option Boards . . . . .	56
4-2	Wiring . . . . .	57
4-2-1	Wire Sizes . . . . .	57
4-2-2	Wiring the Power Supply . . . . .	58

## 4-1 Installation

This section provides precautions on the environmental factors that must be considered and the installation location of each G9SP-series Unit.

### 4-1-1 Installation Location

#### Installation Environment

Do not install the G9SP-series Controller in the following locations.

- Locations subject to ambient temperatures lower than 0°C or higher than 55°C.
- Locations subject to condensation as the result of severe changes in temperature.
- Locations subject to ambient humidity lower than 10% or higher than 90%.
- Locations subject to corrosive or flammable gases.
- Locations subject to excessive dust, salt, or metal filings.
- Locations subject to direct shock or vibration.
- Locations subject to direct sunlight.
- Locations subject to water, oil, or chemicals.

Always enclose or protect the G9SP-series Controller sufficiently in the following locations.

- Locations subject to static electricity or other forms of noise.
- Locations subject to strong electromagnetic fields.
- Locations subject to possible exposure to radioactivity.
- Locations close to power lines.

#### Installation in Control Panels

When the G9SP-series Controller is being installed in a control panel, be sure to provide proper ambient conditions as well as access for operation and maintenance.

#### Installation Orientation

When installing the G9SP-series Controller in a control panel, it must be installed with the side with indicators and communications ports facing the front to ensure proper heat dissipation.

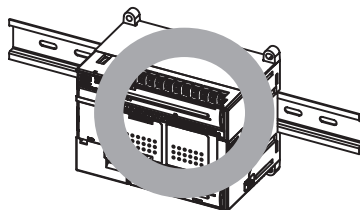



### Accessibility for Operation and Maintenance

- To ensure safe access for operation and maintenance, separate the G9SP-series Controller as much as possible from high-voltage equipment and moving machinery.
- The G9SP-series Controller will be easiest to install and operate if it is mounted at a height of 1.0 to 1.6 m above the floor.

**⚠ Caution** Do not touch the power supply or the area around the I/O terminals while power is being supplied or immediately after power has been turned OFF. Doing so may result in burns.



### Precautions for Correct Use

After the power supply has been turned OFF, wait until the G9SP-series Controller has sufficiently cooled before touching it.

### Improving Noise Resistance

Leave space between the G9SP-series Controller and control panel or other devices to allow adequate dissipation of heat generated by the power supply.

- Do not mount the G9SP-series Controller in a control panel containing high-voltage equipment.
- Install the G9SP-series Controller at least 200 mm (6.5 feet) from power lines.

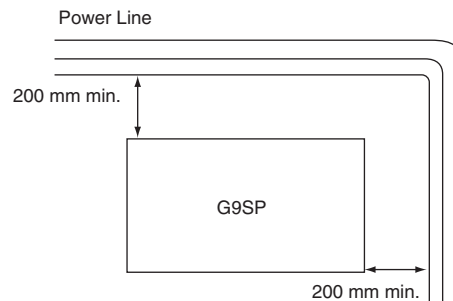

- Ground the mounting plate between the G9SP-series Controller and the mounting surface.

### Temperature Control

The ambient operating temperature around the G9SP-series Controller must be between 0 and 55°C. Observe the following precautions.

- Provide enough space for good air flow.
- Do not install the G9SP-series Controller above equipment that generates a large amount of heat such as heaters, transformers, or high-capacity resistors.
- If the ambient temperature exceeds 55°C, install a cooling fan or air conditioner.

### 4-1-2 Unit Arrangement

This section describes how to arrange the G9SP-series Controller Units. As shown in the following diagrams, Units can be arranged in one or two rows when Expansion I/O Units or Expansion Units are used.

#### Arrangement in One Row

Expansion I/O Units and Expansion Units can be installed in a side-by-side arrangement.

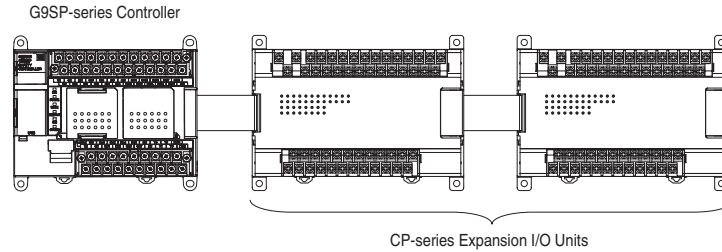

#### Arrangement in Two Rows

The Units can be arranged in two rows using the CP1W-CN811 I/O Connecting Cable (800 mm).

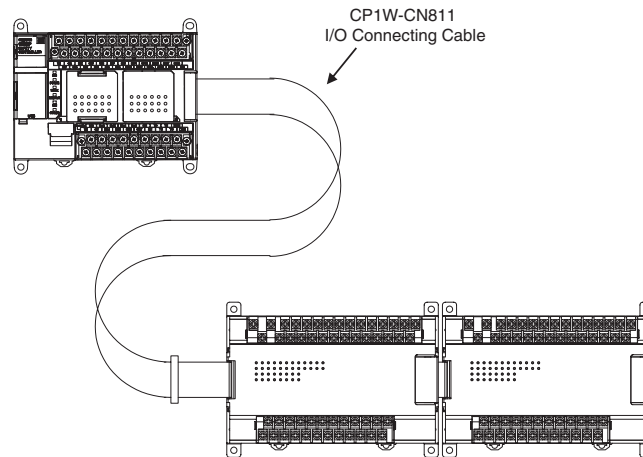

#### Precautions for Correct Use

I/O Connecting Cable can be used in one place only in each Controller. It cannot be used between Expansion I/O Units or in more than one place in the same Controller.

### 4-1-3 Installation

This section describes how to install the G9SP-series Controller.

#### Dimensions and Installation Height

##### Dimensions

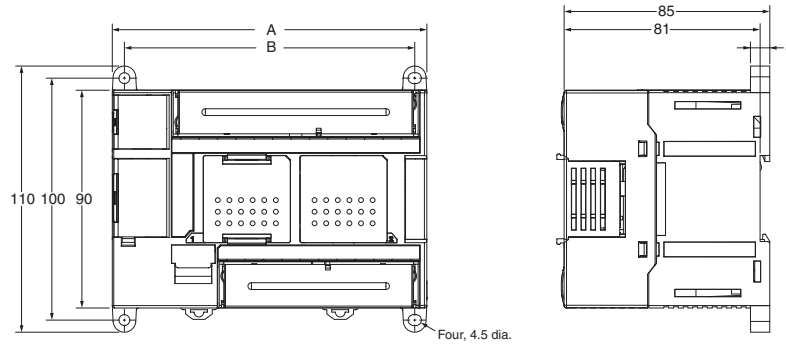

Model number	A	B	Weight
G9SP-N10S	86	76	290 g max.
G9SP-N10D	130	120	440 g max.
G9SP-N20S	130	120	430 g max.

##### Installation Height

The installation height is approximately 90 mm.

When a Connecting Cable is connected to an Option Board, however, the additional height must be included. Always allow for the additional height when considering the depth of the control panel in which the G9SP-series Controller is to be mounted.

#### Installation Methods

There are two installation methods.

##### DIN Track Installation

The Units can be mounted to PEP-50N (50 cm) or PEP-100N/100N2 (100 cm) DIN Tracks. Secure the DIN Track with screws in at least three places.

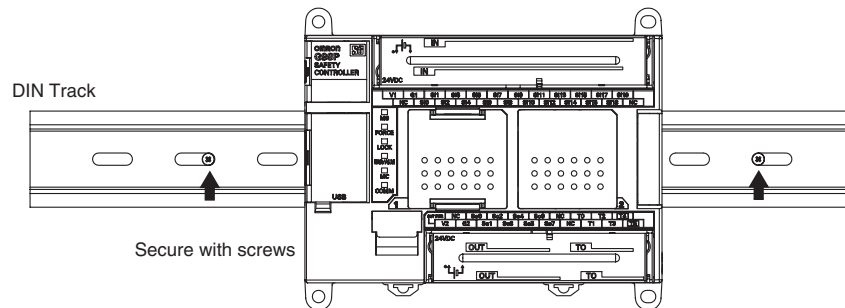

##### Surface Installation

Units can be directly mounted in the control panel using M4 screws.

**Mounting Brackets**

**DIN Track**

Secure the DIN Track to the control panel using M4 screws at interval of 210 mm or less (6 holes or fewer). The tightening torque is 1.2 N·m.

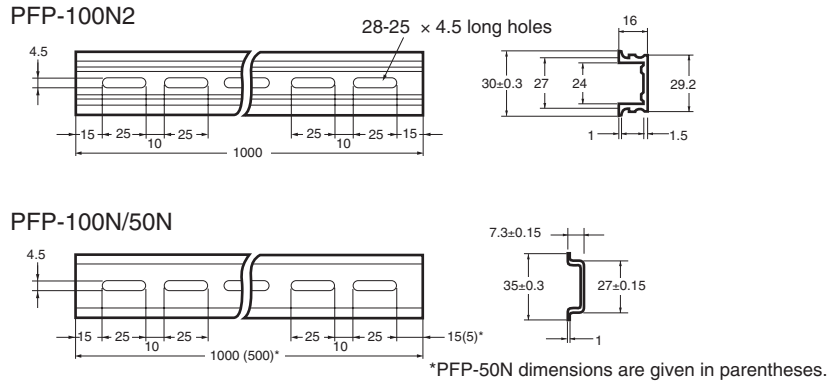

**End Plates**

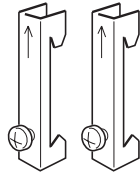

Use the PFP-M End Plates to secure the Units so that they do not move towards one end or the other of the DIN Track.

**Mounting with Screws**

1. Open mounting holes in the mounting surface according to the dimensions diagram.
2. Use M4 screws, which fit the holes on the G9SP-series Controller. The tightening torque is 1.2 N·m.

**4-1-4 Connecting Expansion I/O Units and Expansion Units**

This section describes how to connect Expansion I/O Units and Expansion Units.

**Connection Methods**

- 1,2,3... 1. Remove the cover from the G9SP-series Controller's or the Expansion I/O Unit's expansion connector. Use a flat-head screwdriver to remove the cover from the Expansion I/O Connector.

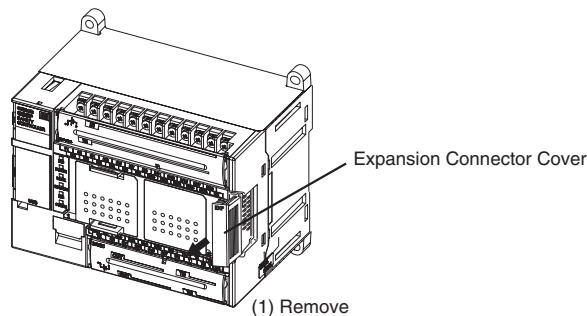

2. Insert the Expansion I/O Unit's connecting cable into the G9SP-series G9SP-series Controller's or the Expansion I/O Unit's expansion connector.

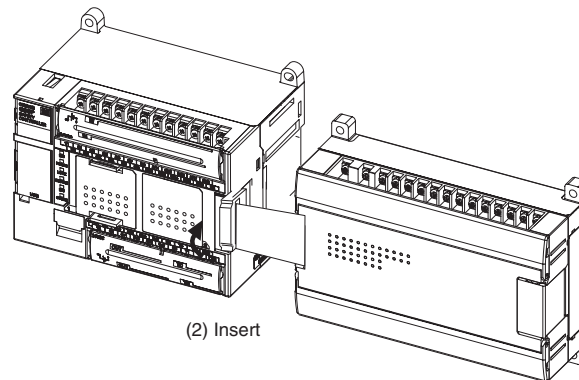

3. Attach the cover to the G9SP-series Controller's or the Expansion I/O Unit's expansion connector.

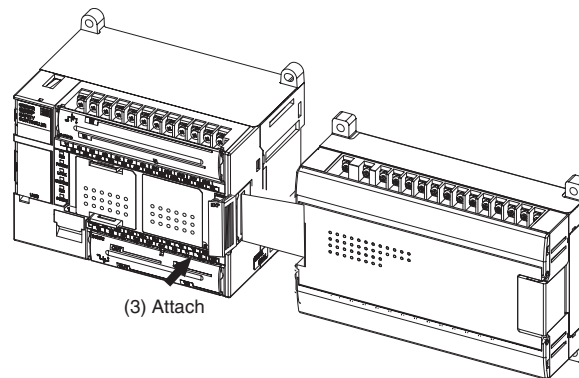

### Precautions for Correct Use

- Always turn OFF the power supply to the G9SP-series Controller before mounting or removing Expansion I/O Units.
- Separate the G9SP-series Controller from the Expansion I/O Units by about 10 mm.

### Precautions on Connecting Units

The following restrictions apply to the Expansion I/O Units that can be connected to the G9SP-series Controller.

#### Applicable Models

Refer to *1-1-2 Basic System and Configuration Devices* and *2-2 Expansion I/O Units* for information on the Expansion I/O Units that can be connected.

#### Maximum Number of Connectable Units

Up to two Expansion I/O Units can be connected.

#### Configuration Data Agreement

If the actual configuration does not agree with the configuration data, a non-fatal error will occur in the G9SP-series Controller. Correct the configuration or the configuration data so that they agree. Refer to *SECTION 13 Troubleshooting* for information on errors.

## 4-1-5 Mounting Option Boards

This section describes how to mount an Option Board.

### Mounting and Removal

#### Mounting

- 1,2,3...**
1. Turn OFF the power supply to the G9SP-series Controller.
  2. Remove the cover to the Option Board slot. If you squeeze the top and bottom lock levers on the cover together to release the lock, you can remove the cover.
  3. Make sure the Board is in the correct orientation and firmly press it into the slot until it clicks into place.

#### Removal

Always turn OFF the power supply before removing an Option Board. If you squeeze the top and bottom lock levers on the Option Board together to release the lock, you can remove the Option Board.



#### **Precautions for Correct Use**

---

Always turn OFF the power supply to the G9SP-series Controller before mounting or removing Option Boards.

---

### Precautions When Connecting an Option Board

The following restrictions apply to the Option Boards that can be mounted to the G9SP-series Controller.

#### Applicable Models

Refer to *1-1-2 Basic System and Configuration Devices* for information on the Expansion I/O Units that can be connected.

#### Maximum Number of Boards

Only one Option Board can be mounted.

## 4-2 Wiring

This section describes wiring methods for the G9SP-series Controller and CP-series Expansion I/O Units.

### 4-2-1 Wire Sizes

Use the following wires to wire the power supply and external I/O devices to the G9SP-series Controller.

Solid wire	0.32 to 0.82 mm <sup>2</sup> , AWG22 to AWG18 0.32 to 0.5 mm <sup>2</sup> , AWG22 to AWG20*
Stranded wire	0.5 to 1.3 mm <sup>2</sup> , AWG20 to AWG16 0.5 to 0.82 mm <sup>2</sup> , AWG20 to AWG18*

\* When wiring two wires to one terminal, use two wires of the same type and thickness.

- M3 self-rising terminals are used on the screw terminals. Tighten the terminal block screws to the torque of 0.5 N·m.
- Use crimp terminals (M3) having the dimensions shown below.

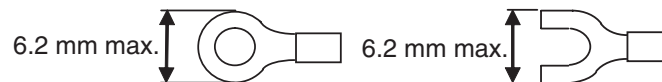

#### Precautions for Safe Use

- Disconnect the G9SP-series Controller from the power supply before starting wiring. Devices connected to the Controller may operate unexpectedly.
- Properly apply the specified voltage to the G9SP-series Controller power supply and input terminals. Applying an inappropriate DC voltage or any AC voltage may result in failure of specified functions, reduced safety functions, damage to the product, and burning.
- Never apply a voltage that exceeds the input voltage for Input Units or the maximum switching capacity for Output Units.
- When the power supply has positive and negative terminals, always wire them correctly.
- Be sure to separate the communications cables and I/O cables from high-voltage/high-current lines.
- Do not bend a cable past its natural bending radius or pull in it with excessive force. Doing so will damage the cable.
- Be careful not to get your fingers caught when attaching terminal blocks to the G9SP-series Controller.
- Incorrect wiring may lead to loss of safety functions. Wire conductors correctly and verify the operation of the G9SP-series Controller before using the system in which the Controller is incorporated.

## 4-2-2 Wiring the Power Supply

### Wiring the Power Supply

The G9SP-series Controller provides power terminals V1/G1 for the internal and input circuits and power terminals V2/G2 for the output circuits.

Use a power supply with a voltage fluctuation range of 20.4 to 26.4 VDC.

- If the voltage may drop due to the starting current or inrush current for output devices, use different power sources for the two power supplies.
- When using more than one G9SP-series Controller, use separate power supply circuits for each G9SP-series Controller to prevent the malfunction of breakers and voltage drops from inrush current.

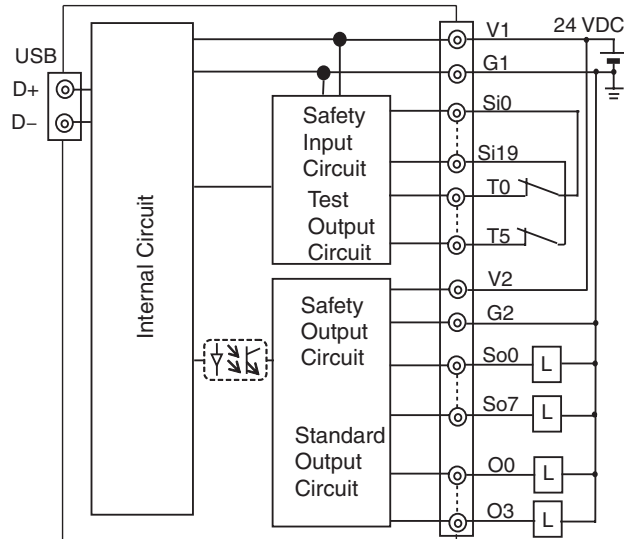

### Power Supply Selection

Use a DC power supply satisfying the following requirements.

- The secondary circuit of the DC power supply must be isolated from the primary circuit by double insulation or reinforced insulation.
- An isolated power supply that is limited to a current of 8 A or lower must be used.
- The output hold time must be 20 ms or longer.
- The DC power supply must be a SELV power supply that satisfies the requirements of IEC/EN 60950-1 and EN 50178.

### Power Supply Grounding

- Ground the 0-V side of the power supply terminals (G1 and G2) to enable detecting faults for disconnected I/O wiring or ground faults.
- Ground to 100  $\Omega$  or less to provide stronger noise immunity.
- Do not share ground lines with other equipment or ground to structural parts of buildings to prevent adverse influences.



### Precautions for Safe Use

- Connect the positive and negative terminals correctly.
- Supply power to all of the Power Supply Units from the same source.





---

**Precautions for Correct Use**

---

- Wiring clippings can scatter when wiring. Leave the label attached to the top of the Unit when wiring to prevent the entry of foreign matter.
  - Remove the label after the completion of wiring to ensure proper heat dissipation.
-



**SECTION 5**

**Preparations for Using the G9SP Configurator**

This section describes the features and provides the installation procedure for the G9SP Configurator. The G9SP Configurator is a software application that is used to program and debug a G9SP-series Controller.

5-1	Overview . . . . .	62
5-1-1	System Requirements and System Configuration . . . . .	62
5-1-2	G9SP Configurator Functions. . . . .	63
5-2	Installation. . . . .	64
5-2-1	Installing the G9SP Configurator . . . . .	64
5-2-2	Installing the USB Driver . . . . .	64

## 5-1 Overview

The G9SP Configurator is a software application that is used to initialize, program, monitor, and debug G9SP-series Controller. This section describes the features of the G9SP Configurator and its system requirements.

### 5-1-1 System Requirements and System Configuration

#### System Requirements

The following system is required to operate the G9SP Configurator. Make sure your system provides the following conditions and has the necessary components.

Item	Description	
Supported computer	IBM PC/AT or equivalent	
CD-ROM or DVD-ROM drive	One or more	
Supported operating systems	Windows 2000 (Service Pack 3 or later) or Windows XP (Service Pack 2 or later)	Windows Vista (except for 64-bit version)
CPU	Pentium II 333 MHz or faster Pentium III 1 GHz or better recommended.	Pentium III 1 GHz or better recommended.
RAM	256 MB min. 512 MB or more recommended	512 MB min. 1 GB or more recommended
Required hard disk space	200 MB min.	
Display	High-brightness display of 800 x 600 SVGA min. 256 colors min.	
Connection port to Controller	USB port	

#### System Configuration

The G9SP Configurator is installed on a computer and connected to the G9SP-series Controller with a commercially available USB cable.

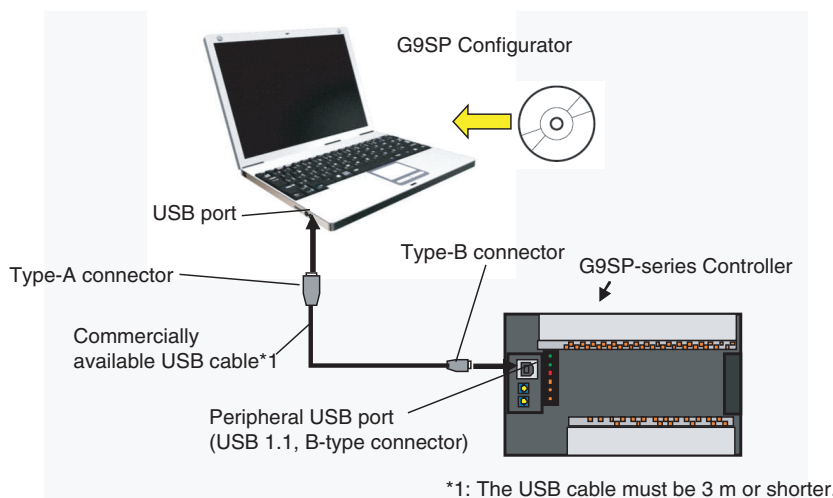



**Precautions for Correct Use**

- The G9SP Configurator cannot be used if it is connected to an RS-232C Option Board or Ethernet Option Board. Always connect it directly to the USB port.
- Do not turn OFF the power supply to the G9SP-series Controller or disconnect the USB cable while online. Before removing the USB cable, place the application offline.

**5-1-2 G9SP Configurator Functions**

The G9SP Configurator can be used for the following purposes.

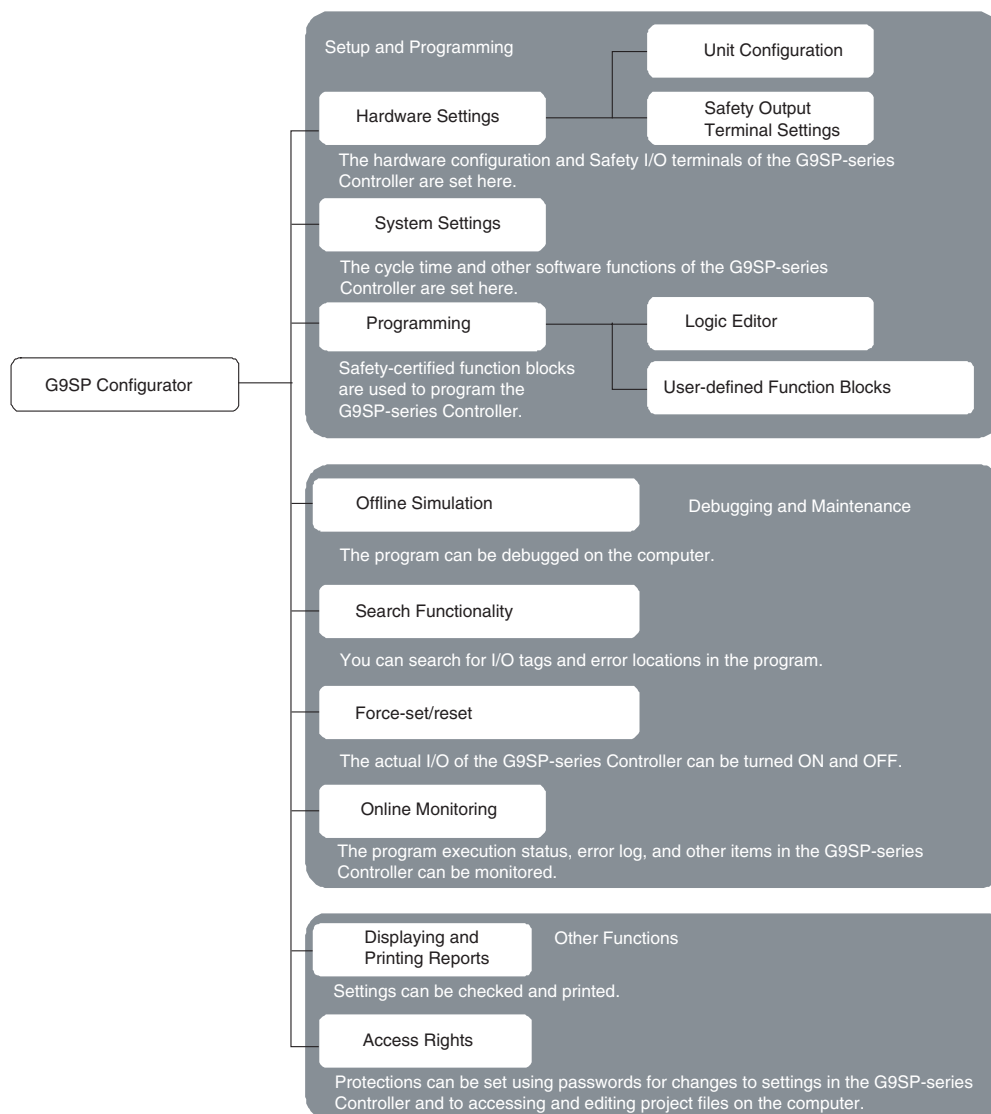

## 5-2 Installation

This section describes the installation procedure that must be performed to use the G9SP Configurator.



### **Precautions for Correct Use**

To install the software, log on as a user that meets the following conditions.

- Administrator privileges
- Only single-byte alphanumeric characters in the user's account name

### 5-2-1 Installing the G9SP Configurator

#### **Preparing for Installation**

Check the following items before beginning with the installation.

##### **Available Hard Disk Space**

The G9SP Configurator can be installed on the hard disk only. At least 200 MB of hard disk space is required. Make sure that there is enough space available.

##### **Windows Environment and Installation Destination**

The G9SP Configurator is a software application for a Windows operating environment. The software is installed on top of Windows. Make sure that Windows Vista, XP or Windows 2000 is installed and functioning correctly on the computer.

#### **Installation Procedure**

This section describes how to install the software on a computer using the following drive configuration as an example.

C drive: Hard disk drive

D drive: CD-ROM drive

- 1,2,3...** 1. Start Windows and insert the G9SP Configurator Master Disk in the CD-ROM drive. The installation program will be started by the computer's auto-run function. If the installation program does not start, select **Specify File Name and Run** from the Windows Start Menu, enter "d:\setup" and click the **OK** Button.
2. Complete the installation process following the instructions provided on-screen.

#### **Uninstalling the G9SP Configurator**

Uninstall the G9SP Configurator when it is no longer required. Uninstall the application using Add and Remove Applications in the control panel.

### 5-2-2 Installing the USB Driver

The USB driver for the G9SP-series Controller must be installed on the computer running the G9SP Configurator in order to connect the G9SP-series Controller to the computer via USB. The USB driver is stored in the following directory in the computer when the G9SP Configurator is installed.

C:\Program Files\OMRON\G9SP Configurator\Drivers\USB

**Windows 2000 or XP**

The procedure to install the driver on a Windows 2000 or Windows XP computer is given in this section.

1,2,3...

1. Turn ON the power supply to the G9SP-series Controller and connect the USB port on the G9SP-series Controller to a USB port on the computer using a USB cable.

The computer will automatically detect the G9SP-series Controller when the cable is connected and display a message saying that new hardware has been detected. The Add Hardware Wizard will also be displayed.

2. In the Found New Hardware Wizard Dialog Box, select the *No, not this time* option and click the **Next** Button.

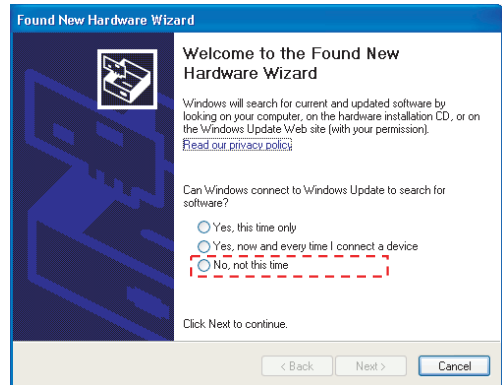

3. Select the *Install from a list or specific location (Advanced)* Option and click the **Next** Button.

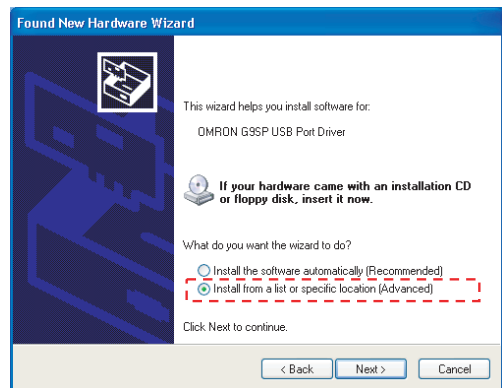

4. Select the *Search the best driver in these locations* Check Box and select only the *Include this location in the search* Option. Specify the directory where the USB driver was saved (given previously) as the location to search and click the **Next** Button.

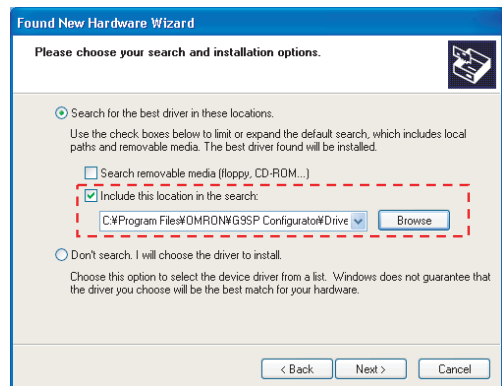

5. If a warning message appears saying that the driver has not passed the Windows logo test, ignore it and click the **Continue Anyway** Button.

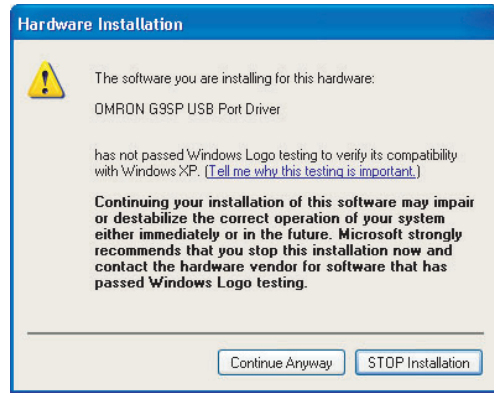

6. The driver will be installed.
7. This dialog box will be displayed if the installation is completed normally. Click the **Finish** Button.



This completes installation of the USB driver for the G9SP Configurator.

## Windows Vista

The procedure to install the driver on a Windows Vista computer is given in this section.

1,2,3...

1. Turn ON the power supply to the G9SP-series Controller and connect the USB port on the G9SP-series Controller to a USB port on the computer using a USB cable. The computer will automatically detect the G9SP-series Controller when the cable is connected and display a message saying that new hardware has been detected. The Add Hardware Wizard will also be displayed.
2. Select the *Don't show this message again for this device* Option in the Found New Hardware Dialog Box.

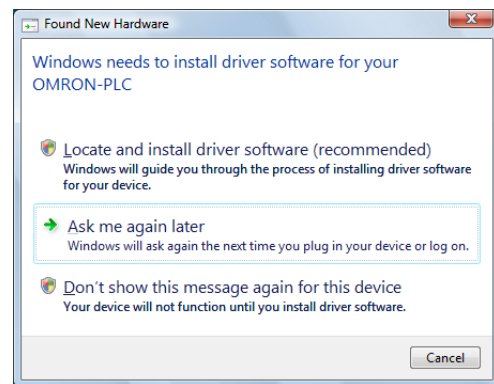



- 3. Click the **Next** Button.

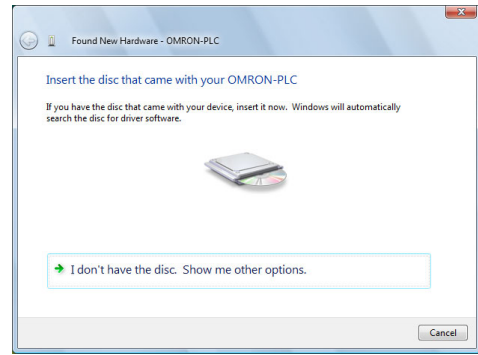

- 4. Select the *Browse my computer for driver software (advanced)* Option.

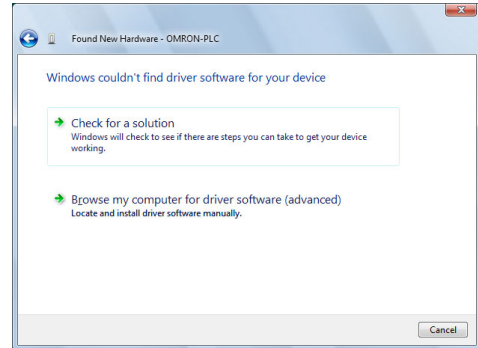

- 5. Click the **Browse** Button, specify the directory where the USB driver was saved (given previously) as the location to search and click the **Next** Button.

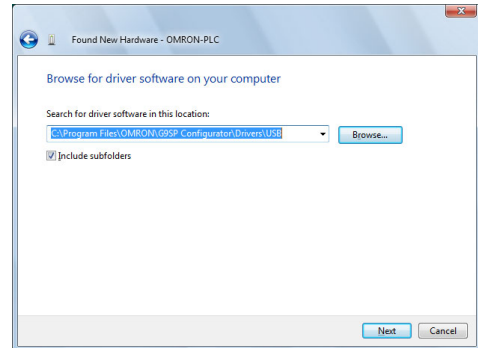

- 6. If a warning message appears saying that the driver has not passed the Windows logo test, ignore it and click the **Continue Anyway** Button.

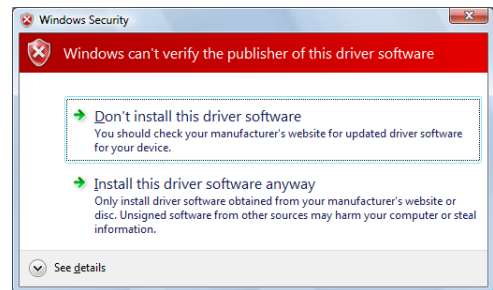

7. The driver will be installed.
8. Click the **Close** Button to finish installing the USB Port Driver.

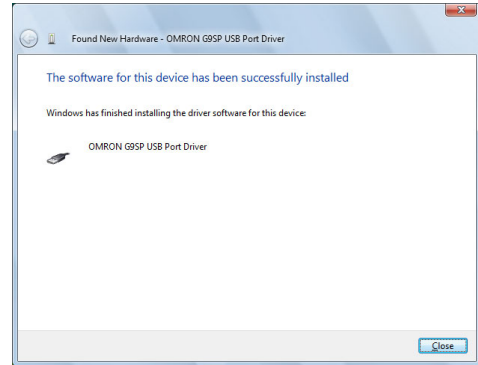

This completes installation of the USB driver for the G9SP Configurator.

### Confirming Installation

Check that the driver has been installed correctly after the installation.

**1,2,3...**

1. From the desktop click **Start**, right-click **My Computer**, and select **Properties**. The **System Properties** Dialog Box will be displayed.
2. Click the **Hardware** Tab and click the **Device Manager** Button. The **Device Manager** Dialog Box will be displayed.

3. Double-click the USB (Universal Serial Bus) Controller Device. Check that **OMRON G9SP USB Port Driver** is displayed. If it is displayed, then the USB driver has been installed correctly.

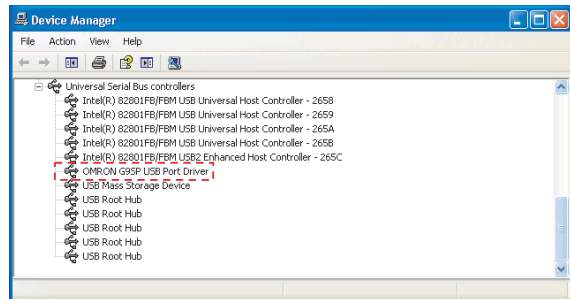

### If the Installation Fails

**1,2,3...**

1. Display the Device Manager on the computer. If **USB Device** is displayed for **Other Devices**, it means that the USB driver installation has failed.
2. Right-click on **USB Device** and select **Delete** to delete the driver. Reinsert the USB cable to display the USB driver installation dialog box. Install the driver following the instructions again.

## SECTION 6 Creating Configuration Data

This section describes the procedures for creating configuration data for G9SP-series Controllers using the G9SP Configurator.

6-1	Overview . . . . .	70
6-2	Creating Configuration Data . . . . .	71
6-2-1	Starting the G9SP Configurator . . . . .	71
6-2-2	Hardware Settings. . . . .	71
6-2-3	Programming . . . . .	73
6-2-4	System Settings. . . . .	76
6-2-5	Displaying and Printing Reports. . . . .	77
6-3	Designing Device Security . . . . .	78
6-4	Offline Simulation. . . . .	83
6-4-1	Basic Procedure . . . . .	83
6-4-2	Convenient Usage to Increase Debugging Efficiency. . . . .	84
6-5	Creating and Using User-defined Function Blocks. . . . .	87
6-5-1	Application Examples. . . . .	87
6-5-2	Specifications . . . . .	88
6-5-3	Operation rights . . . . .	88
6-5-4	Creating User-defined Function Blocks . . . . .	88
6-5-5	Exporting User-defined Function Blocks . . . . .	89
6-5-6	Importing User-defined Function Blocks . . . . .	90

## 6-1 Overview

Configuration data for the G9SP-series Controller is created using the G9SP Configurator.

### G9SP Configurator Screen

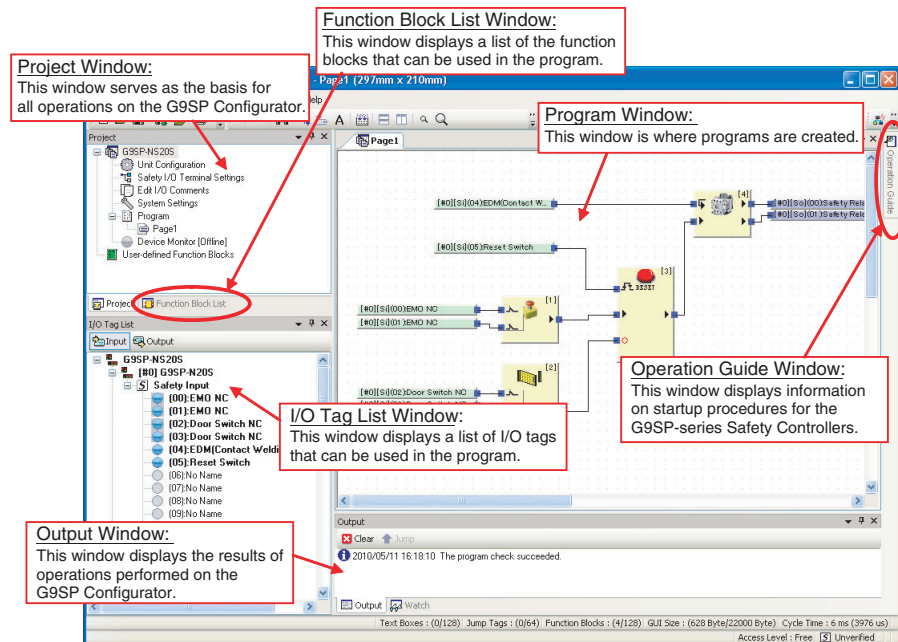

### Basic Workflow

Configuration data for the G9SP-series Controller is created basically using the following workflow.

1. Starting the G9SP Configurator.
2. Hardware setup (e.g., selecting I/O devices to connect in the unit configuration)
3. Programming
4. System settings
5. Displaying and printing reports
6. Designing device security
7. Desktop debugging (i.e., analysis and offline simulation using searches)

## 6-2 Creating Configuration Data

First, start the G9SP Configurator, and then make the hardware settings, perform programming, and make the system settings, in that order.

### 6-2-1 Starting the G9SP Configurator

- 1,2,3...
1. Select **Programs/All Programs - OMRON G9SP Configurator - G9SP Configurator** from the Windows Start Menu.
  2. Select **Create New Project** or **Open Existing File** from the Startup Operation Selection Guide.

This section describes how to create a new project using an example from *Appendix A Emergency Stop Pushbutton Application*.

### 6-2-2 Hardware Settings

First, make the hardware settings for the G9SP-series Controller.

- 1,2,3...
1. Unit Configuration  
 Drag and drop the model of the G9SP-series Controller and the Expansion I/O Units to connect. It is not necessary to select the option board to connect.

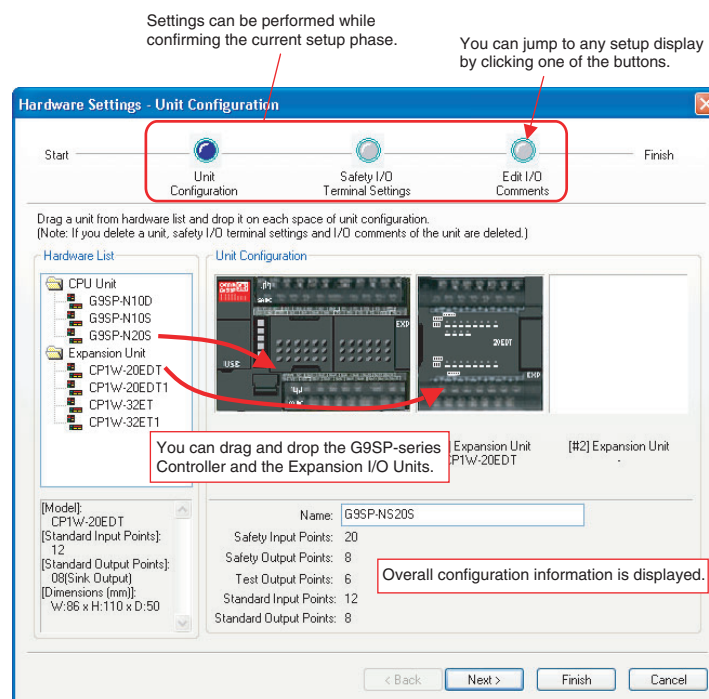

2. Selecting I/O Devices to Connect  
 Select the external devices to connect to the Safety I/O terminals. Also, edit the I/O comments and test sources. For details on Safety I/O functionality, refer to *2-1-5 Safety Inputs* and *2-1-6 Safety Outputs*.

■ Safety Output Terminals

First, drag and drop the external devices to connect to the Safety Output terminals.

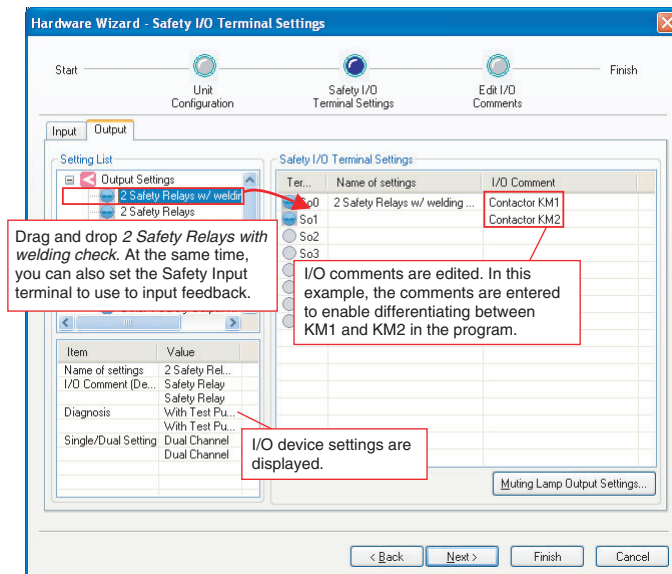

■ Safety Input Terminals

Next, drag and drop the external devices to connect to the Safety Input terminals.

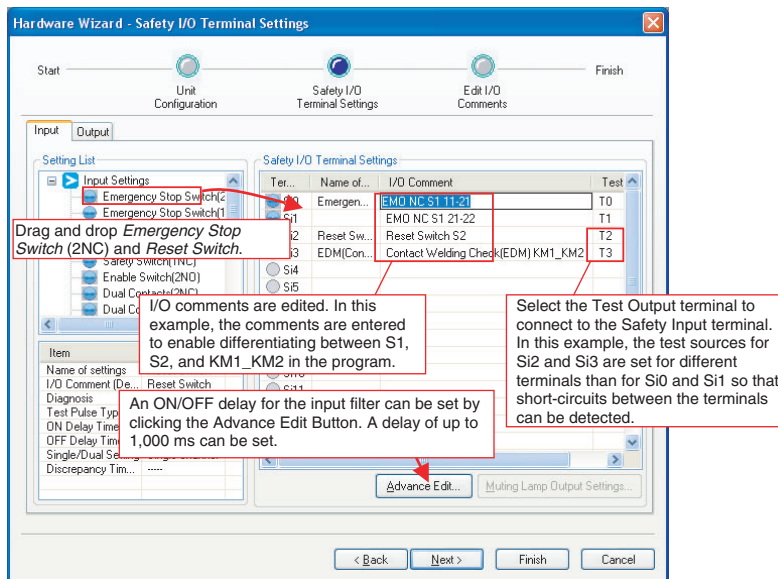

- Note**
- (1) For an I/O comment, you can use up to 48 single-byte characters, except for the following characters: \ / : \* ? " < > | % #.
  - (2) If an Ethernet Communications Option Board is used, TCP/IP settings, such as the IP address, must be made in the system settings. In that case, T3 cannot be used as the test pulse output terminal.

3. Editing I/O Comments

In the last display, you can check and edit comments for I/O terminals. I/O comments for Expansion I/O Units can also be entered in this display.

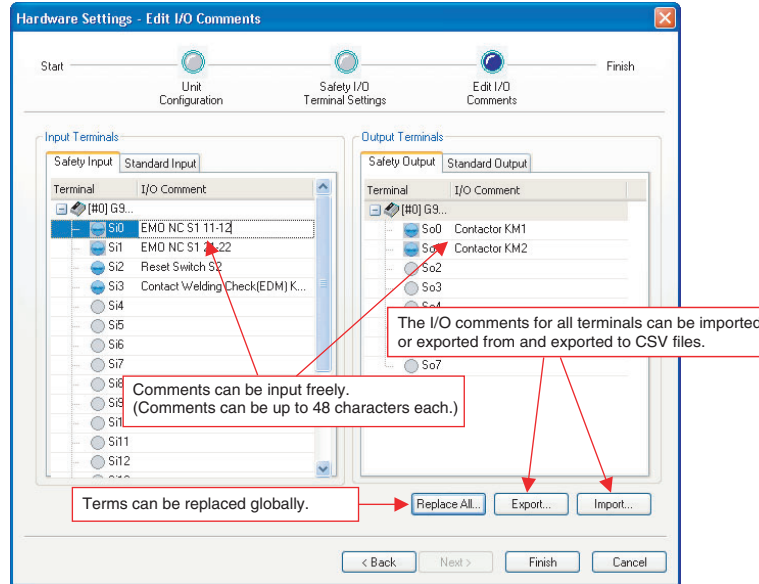

6-2-3 Programming

Perform programming for the safety circuits after completing the hardware setup. Programming can be performed easily and intuitively simply by connecting function blocks certified for safety standards with lines to I/O tags that indicate the values of I/O terminals and communications data. Also, the ability to place I/O tags and function blocks as desired enables creating programming that are exceptionally easy to read and interpret.

Refer to the *G9SP-series Safety Controller Instructions Reference Manual* (Cat. No. Z923) for information on function blocks and specifications.

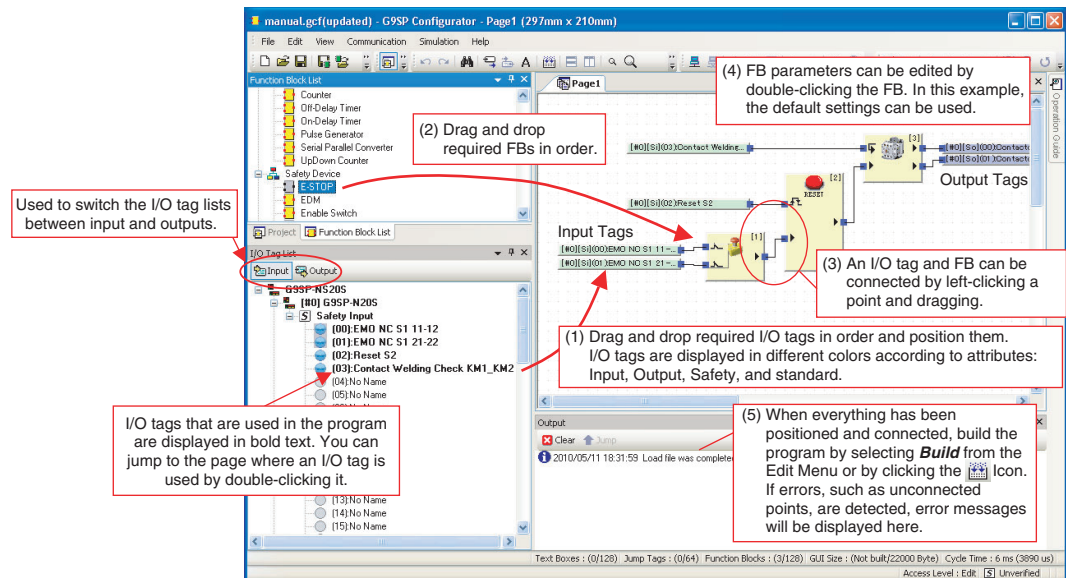

## I/O Tags

### What Are I/O Tags?

I/O tags are I/O data that reflect the values of I/O terminals and communications data. Tags called I/O comments can be used to identify the tags to allow programming without concern for address allocations in the G9SP-series Controller.

### I/O Tags Supported in Programming

Refer to 1-1-2 I/O Tags in the G9SP-series Safety Controller Instructions Reference Manual (Cat. No. Z923).

### Relation to I/O Comments

I/O comments that are set for I/O terminals are reflected in the I/O tags. In this example, *Emergency Stop NC S1 11-12* and an I/O comment are set for Safety Input terminal Si0, and so that name is reflected in the input tags.

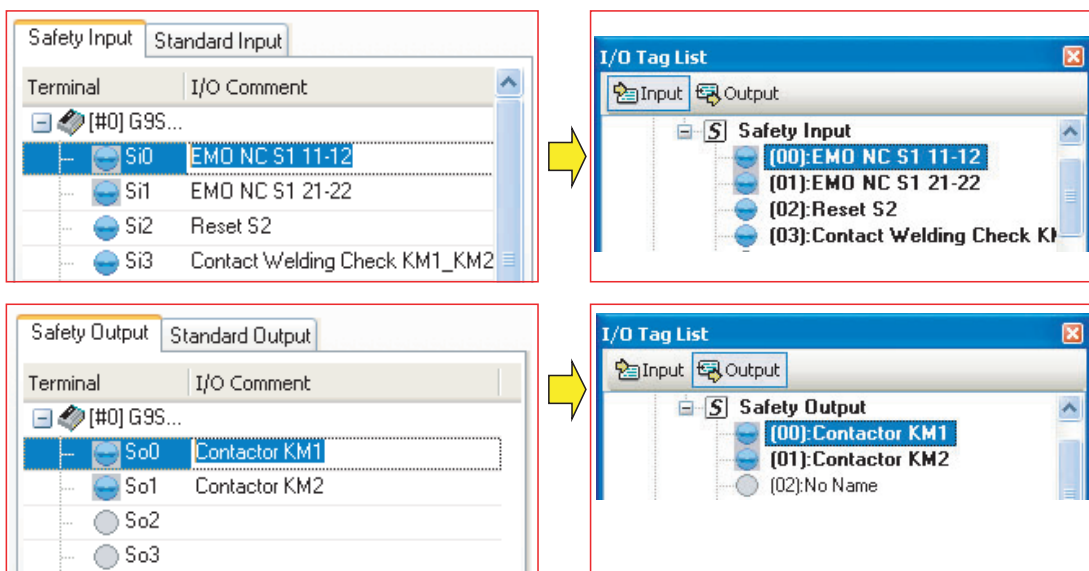

## Convenient Functions to Increase Programming Efficiency

This section describes functions that are convenient for increasing programming efficiency.

### Text Boxes and Function Block Comments

Text and function block comments can be added as desired to improve program legibility.

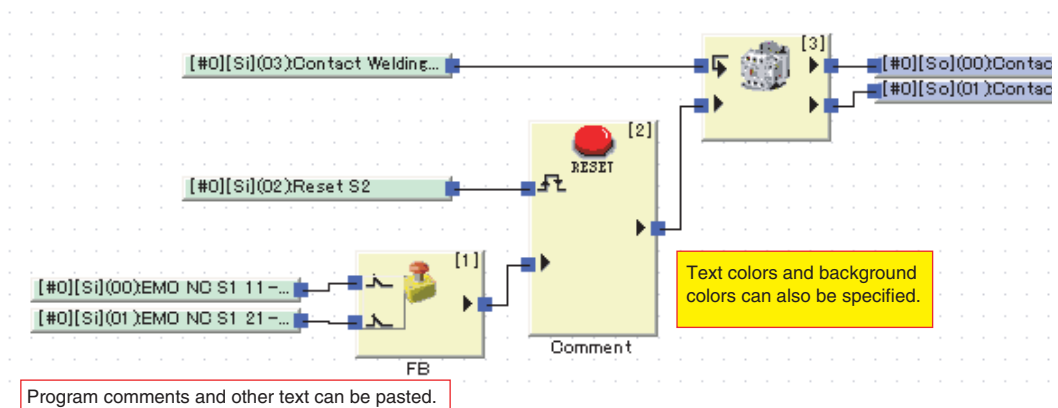



## Page and Jump Tags

A program can be created using up to 16 pages. Programming can be created for better legibility and analysis by dividing pages according to functions like emergency stops and controller status monitoring or according to location, such as robot A and control panel B. Jump tags (64 jumps max.) are used to transfer data between pages.

## Search Functionality

Search functionality is included to aid program analysis.

### ■ Searching for Used I/O Tags

I/O tags that are being used are displayed in bold text in the I/O tag list. When you double-click one of these, the display will jump to the page where the tag is used, and the I/O tag will flash red. Also, when you double-click a jump tag, the display jumps to the linked jump tag.

### ■ Searching for Text Strings

You can search for an I/O tag or function block using a text string by selecting **Find** from the Edit Menu. When you double-click the search results, the display will jump to the page where the I/O tag or function block is used, and the I/O tag or function block will flash red.

### ■ Searching for Program Error Locations

Build errors are displayed in the Output Window. When you click on an error, the display will jump to the relevant page, and the relevant I/O tag or function block will flash red.

## User-defined Function Blocks

You can combine combinations of function blocks into one user-defined function block. Converting frequently used combinations into user-defined function blocks enables creating program components and standardization. It also improves programming efficiency. Refer to 6-5 *Creating and Using User-defined Function Blocks* for details.

## Programming Precautions

This section describes the minimum cautions to keep in mind when programming.

## Building Programs

Programs created using the G9SP Configurator are converted to downloadable data when the program is built. Building is executed automatically when downloading starts, but it can also be executed manually to check the program. (Select **Build** from the Edit Menu or click the  icon.) The program capacity and program execution sequence (described below) are also updated when the program is built.

## Program Size

You can check the size of the program at any time at the bottom of the display. Be careful not to exceed the maximum sizes (i.e., the denominators).

The GUI size is the size of the information required to display programs. This information includes information on function block locations, text boxes, etc.

Text Boxes : (0/128) | Jump Tags : (0/64) | Function Blocks : (3/128) | GUI Size : (469 Byte/22000 Byte) | Cycle Time : 4 ms (3890 us)

### Program Execution Sequence

Function blocks are executed sequentially for each page.

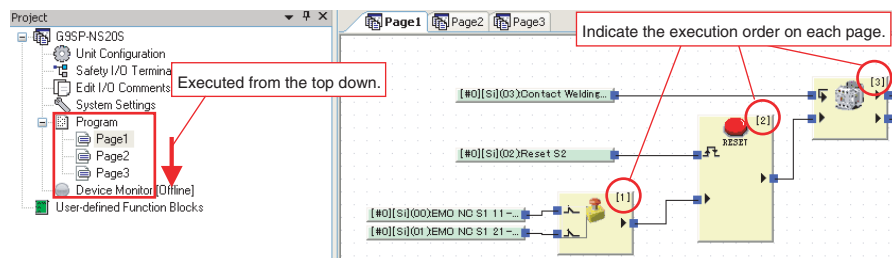

### Loopback Connections

A loopback connection can be created by connecting the output terminal from the function block that comes later in the execution order to the input terminal to a function block that comes earlier in the execution order. A jump tag is used to make the loopback connection.

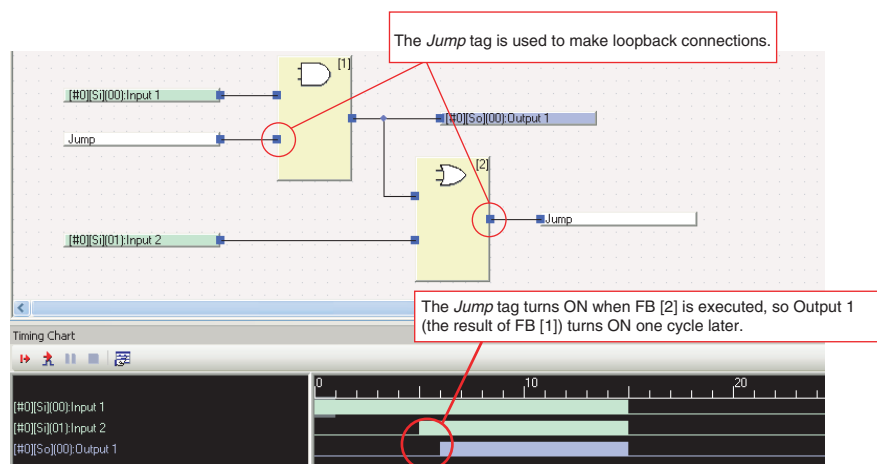

## 6-2-4 System Settings

System settings are performed only after programming has been completed. It is normally not necessary to change the system settings. Make the settings in the following cases.

The system settings are accessed from the Project Window.

#### ■ Manually Setting the Cycle Time

The G9SP Configurator calculates and automatically sets the minimum cycle time supported for operation according to the program contents and Safety Input terminal settings. Therefore, the cycle time depends on the program content and capacity, and recalculation of safety response performance is required. This can be avoided by manually inputting the cycle time.

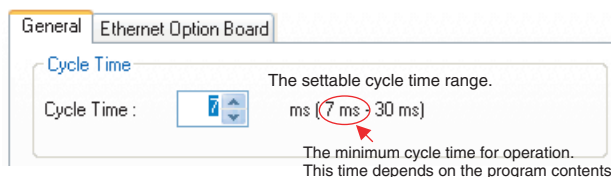

#### ■ Prohibiting Using a Memory Cassette to Restore Memory

Change the system setting to use the prohibit restore setting described in 11-3 Restoring Data to G9SP-series Controller.

■ **Using a CP1W-CIF41 Ethernet Communications Board**

TCP/IP settings, such as the IP address, must be made in the system settings if an Ethernet Communications Option Board is used. Refer to *7-3 Ethernet Communications* for details on settings.

**6-2-5 Displaying and Printing Reports**

A report (i.e., a configuration report) on the configuration data that has been set is displayed on the computer screen to check setting details.

**What Is a Report?**

The G9SP Configurator creates two types of reports. The characteristics of each type are given in the following table.

Item	Configuration report	Verification report
Purpose	<ul style="list-style-type: none"> <li>• Documentation showing the configuration data contents.</li> <li>• Notification to hardware designers.</li> </ul>	Checking if the configuration data has been correctly downloaded to the G9SP-series Controller.
Displayed contents	Configuration data	Verification results and configuration data.
Printing	Supported	Supported
Saving to file	Not supported	Supported
Display timing	When <b>Print Preview</b> is selected from the File Menu.	After executing <b>Communication - Verify</b> .

- Note**
- (1) Refer to *8-2-3 Verifying the Configuration Data* for information on verification.
  - (2) The configuration report can be saved to a file by using commercially available PDF creation software.

**Configuration Data Application Example**

■ **Documentation Showing the Configuration Data Contents**

Forming the details of settings made with the G9SP Configurator into a report enables using the data for other applications.

■ **Notification to Hardware Designers**

Hardware designers require information on the I/O terminal allocations, cycle time, and ON/OFF delay values to create wiring diagrams and to calculate safety response performance. The report includes that information and can be used as documentation for notification of details.

## 6-3 Designing Device Security

This section describes how to set access restrictions with passwords to prevent improper access to project files created using the G9SP-series Controller or G9SP Configurator.

### Password Types and Application Examples

The following two types of passwords can be used.

Password type		Description	Timing of setting in G9SP-series Controller	Password entry
Parameter passwords	Editable	Password to restrict editing of configuration data included in project file.	When downloaded. <i>8-2 Downloading Configuration Data to the G9SP-series Controller and Verification</i>	<ul style="list-style-type: none"> <li>• When opening a project file.</li> <li>• When uploading.</li> <li>• When changing a parameter password.</li> </ul>
	Read only	Password to restrict reading.		
Device password		Password to restrict access to G9SP-series Controller.	When device password is changed. <i>8-5 Setting a Device Password</i>	<ul style="list-style-type: none"> <li>• When downloading.</li> <li>• When changing modes.</li> <li>• When locking the configuration.</li> <li>• When resetting.</li> <li>• When device password is changed.</li> </ul>



#### **Precautions for Correct Use**

- For security, we recommend you set a device password and a project file password.
- There is no way to recover a parameter password if it has been lost, and so a project file with no set password must be separately saved if a parameter password is set.
- The parameter password is enabled when the project is downloaded to the G9SP-series Controller. Always download the project after setting the password.
- Refer to *8-5 Setting a Device Password* for information on measures when the device password is lost.

### Project File Rights

Project file rights are determined by the results of parameter password verification. The following describes the file rights.

Operation rights	Meaning
Free	A parameter password is not set.
Edit right	The project file can be browsed and edited.
Read-only right	The project file can be only browsed.
None	The project file cannot be edited or browsed. The error log can be checked using the device monitor.

**Using Passwords**

This section describes how to use passwords for the following typical cases.

**Restricting Only Access to the G9SP-series Controller**

Set only a device password.

Passwords and main settings		User rights	
		User A (e.g., design manager)	User B (e.g., equipment operator)
Passwords	Parameter password edit right	-	-
	Parameter password read-only right	-	-
	Device password	Allowed	Not allowed
Main operations	Editing parameters and programs	Allowed	Allowed
	Reading parameters and programs, displaying, printing, and verification reports	Allowed	Allowed
	Downloading, changing modes, resetting, and locking the configuration	Allowed	Not allowed
	Debugging with the program monitor	Allowed	Allowed
	Debugging (e.g., error/operation logs) with the device monitor	Allowed	Allowed
	Changing the device password	Allowed	Not allowed

■ **Setting Procedure**

Connect the G9SP-series Controller online and then set the device password. For details, refer to 8-5 *Setting a Device Password*.

■ **Verification Procedure**

The G9SP Configurator will prompt you to input the device password when downloading or changing modes. Input the set device password.

**Restricting Access to the G9SP-series Controller and Reading Parameters**

Set the parameter password for reading, parameter password for editing, and device password.

Passwords and main settings		User rights		
		User A (e.g., design manager)	User B (e.g., maintenance personnel)	User C (e.g., equipment operator)
Passwords	Parameter password edit right	Allowed	Not allowed	Not allowed
	Parameter password read-only right	-	Not allowed	Not allowed
	Device password	Allowed	Allowed	Not allowed
Main operations	Editing parameters and programs	Allowed	Not allowed	Not allowed
	Reading parameters and programs, displaying, printing, and verification reports	Allowed	Not allowed	Not allowed
	Downloading, changing modes, resetting, and locking the configuration	Allowed	Allowed	Not allowed
	Debugging with the program monitor	Allowed	Not allowed	Not allowed
	Debugging (e.g., error/operation logs) with the device monitor	Allowed	Allowed	Allowed
	Changing the device password	Allowed	Allowed	Not allowed

■ **Setting Procedure**

- 1,2,3... 1. In the following dialog box for changing the parameter password, enter the present parameter password for editing, present password for reading, new password for editing, and new password for reading. Enter the same password for editing and reading.

The text box will be empty when no password is set.

The password must be between 6 and 16 alphanumeric characters. Input the same password for editing and browsing.

Input the same password.

2. Connect the G9SP-series Controller online and then set the device password.

■ **Verification Procedure**

- 1,2,3... 1. The G9SP Configurator will prompt you to input the parameter password when a project file is opened or configuration data is uploaded. Input the set password for editing and password for reading. The project file will open with the edit right if the passwords match. If the passwords do not match and the **Cancel** Button is clicked, the project file will open without rights.

Parameter password for editing	Parameter password for reading	Project file operation rights
Match		Edit right
Do not match		None

2. The G9SP Configurator will prompt you to input the device password when downloading or changing modes. Input the set device password.

**Restricting Access to the G9SP-series Controller and Editing or Reading Parameters**

Set the parameter password for reading, parameter password for editing, and device password.

Passwords and main settings		User rights			
		User A (e.g., design manager)	User B (e.g., startup debugging personal)	User C (e.g., maintenance personnel)	User D (e.g., equipment operator)
Passwords	Parameter password edit right	Allowed	Not allowed	Not allowed	Not allowed
	Parameter password read-only right	-	Allowed	Not allowed	Not allowed
	Device password	Allowed	Allowed	Allowed	Not allowed
Main operations	Editing parameters and programs	Allowed	Not allowed	Not allowed	Not allowed
	Reading parameters and programs, displaying, printing, and verification reports	Allowed	Allowed	Not allowed	Not allowed
	Downloading, changing modes, resetting, and locking the configuration	Allowed	Allowed	Allowed	Not allowed
	Debugging with the program monitor	Allowed	Allowed	Not allowed	Not allowed
	Debugging (e.g., error/operation logs) with the device monitor	Allowed	Allowed	Allowed	Allowed
	Changing the device password	Allowed	Allowed	Allowed	Not allowed

**■ Setting Procedure**

- 1,2,3... 1. In the following dialog box for changing the parameter password, enter the present parameter password for editing, present password for reading, new password for editing, and new password for reading. Enter different passwords for editing and reference.

2. Connect the G9SP-series Controller online and then set the device password.

■ Verification Procedure

- 1,2,3... 1. The G9SP Configurator will prompt you to input the parameter password when a project file is opened or configuration data is uploaded. Input the set password for editing or password for reading.

The project file will open with the edit right if the password matches the parameter password for editing. The file will open with the read-only right if the password does not match the parameter password for editing but does match the parameter password for reading. If the passwords matches neither password and the **Cancel** Button is clicked, the project file will open without rights.

Parameter password for editing	Parameter password for reading	Project file operation rights
Match	(Verification skipped.)	Edit right
Do not match	Match	Read-only right
Do not match	Do not match	None

2. The G9SP Configurator will prompt you to input the device password when downloading or changing modes. Input the set device password.



## 6-4 Offline Simulation

The operation of the G9SP-series Controller's programming can be checked by performing simulation on a computer.

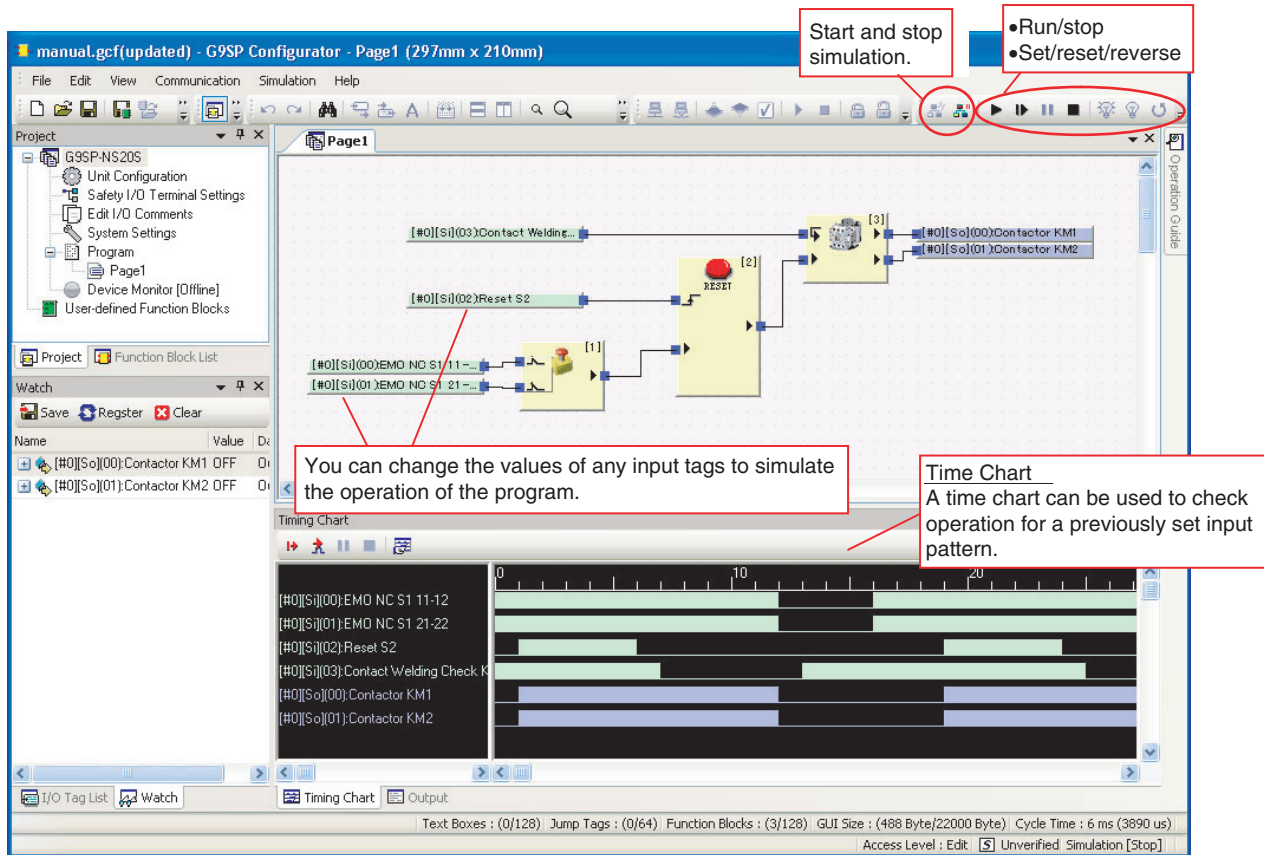



**Note** Simulation cannot be used during online monitoring. Disconnect the online connection before starting simulation.





### 6-4-1 Basic Procedure

This section describes the basic procedure for simulation.

#### Starting Simulation

- 1,2,3...**
1. Check that the G9SP Configurator is offline .
  2. Click the Start Simulation Icon . The background of the Program Window will turn pink.

#### Executing Simulation

- 1,2,3...**
1. Click the Program Operation Icon .
  2. Debug the program by selecting the desired I/O tag and then clicking the Set Icon , Reset Icon , and Reverse Icon .

## 6-4-2 Convenient Usage to Increase Debugging Efficiency

This section describes convenient applications to increase debugging efficiency using simulation.

### Initial Value Settings

You can set the initial values for input tags when execution of simulation starts. This is useful when reproducing the actual system status or when evaluating test cases using similar input status.

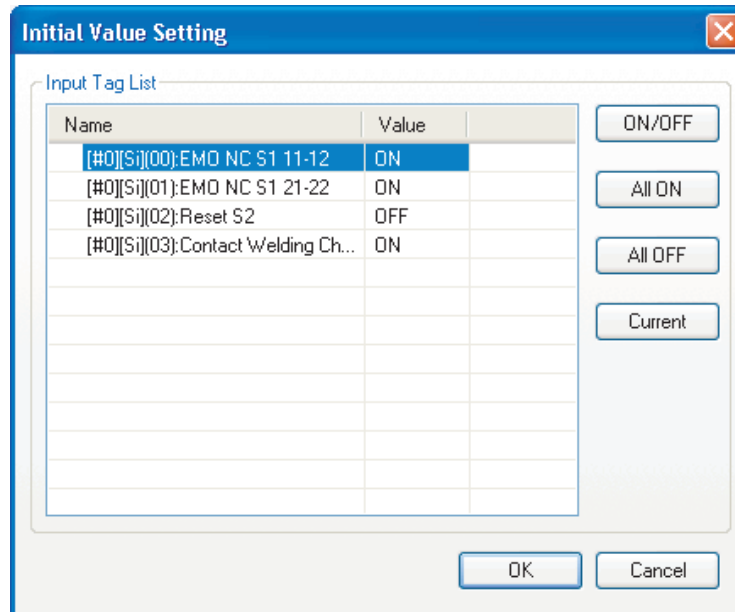

**Feedback Settings**

You can set an input status that changes in conjunction with the output status, such as for safety relay feedback inputs.

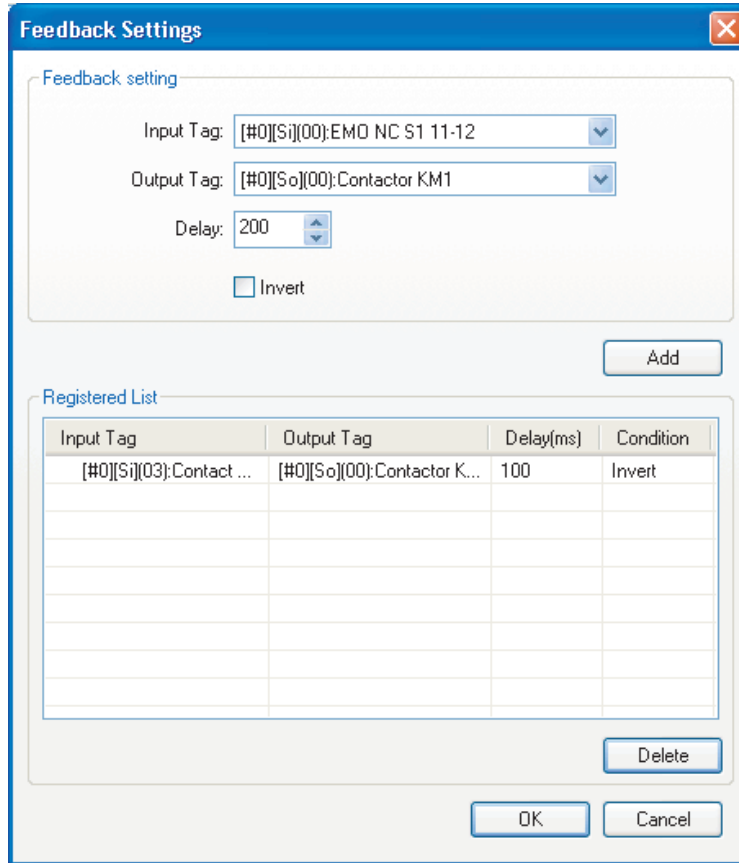



**Simulation Using a Timing Chart**

You can perform simulation for changes in output status with input patterns set in advance using a timing chart.

**Registration to the Timing Chart**

In the Program Window, select the registered I/O tag, and then right-click and select **Register to Timing Chart Window**.

**Executing the Timing Chart**

- 1,2,3... 1. Input ON/OFF patterns for the input tags that you add to the timing chart.  
 2. Click the **Execute Timing Chart** icon . Click the  icon to execute one pulse (i.e., step) at a time.

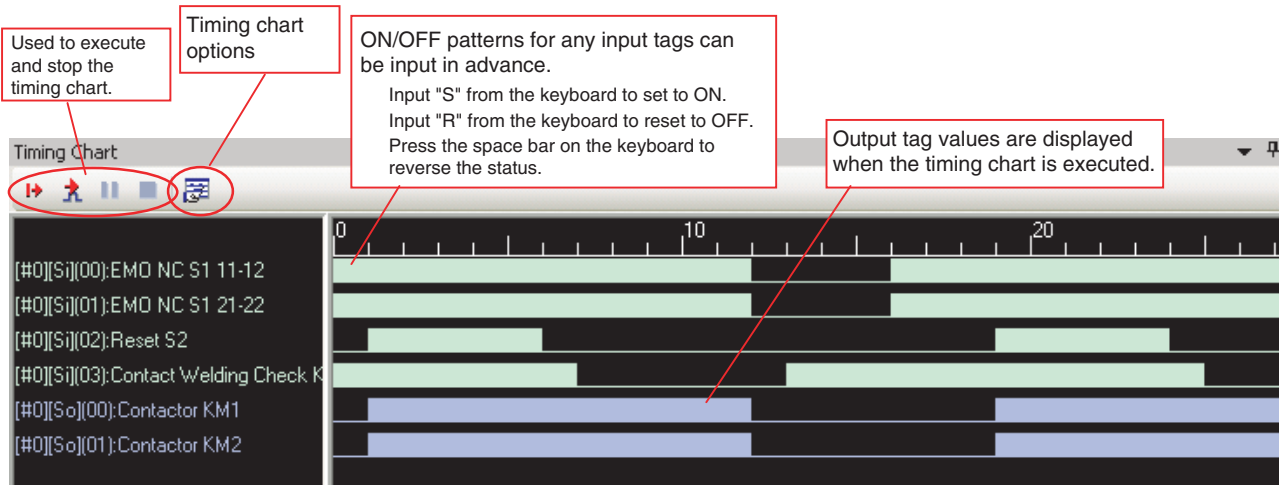

- Note**
- (1) Executing simulation using the Program Window and executing simulation using the timing chart cannot be performed at the same time.
  - (2) The time for one pulse can be set using the timing chart options.

## 6-5 Creating and Using User-defined Function Blocks

The function blocks provided by the G9SP Configurator can be combined by the user to create new function blocks called user-defined function blocks. These user-defined function blocks can be used to reuse programming.

### 6-5-1 Application Examples

#### Unifying Programming in Different Locations

When the same programming is used in different locations, the programming can be defined as a user-defined function block. This reduces maintenance work when changes are required to the programming contained in the user-defined function block.

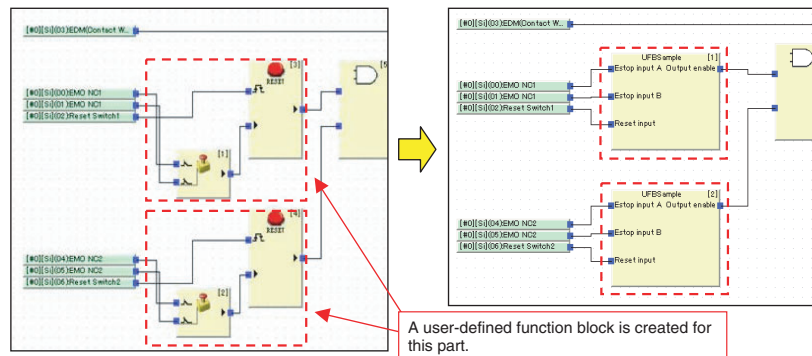

#### Reusing Programming from Other Project Files

User-defined function blocks that were created in other project files can be imported and exported. This enables using programming that has already been debugged, to reduce programming work and improve quality.

#### Increasing Program Structure and Readability

All of the function blocks used in a user-defined function block are seen as only one function block. This helps to make programs more structured, which makes them more readable.



#### **Precautions for Correct Use**

- Using user-defined function blocks does not reduce the program size. For example, if a user-defined function block that contains five function blocks is used three times, the number of function blocks will be 5 times 3, or 15 function blocks.
- To use user-defined function blocks, you must have Windows administrator or power user rights.
- You can register up to 256 user-defined function blocks in the Project Window.
- You can create up to 16 folders in the User-defined Function Block folder.
- You can use up to 48 characters in a user-defined function block name, page name, or folder name.
- You can use between 6 and 16 alphanumeric characters in the editable or read only password.
- You can position up to 128 user-defined function blocks in the Editor.

### 6-5-2 Specifications

The specifications of user-defined function blocks are given below.

Item	Specification
Maximum number of I/O terminals	Input terminals: 32, Output terminals: 16
Maximum number of function blocks	128
Maximum number of pages	32
Maximum number of jump tags	64
I/O comment size	48 alphanumeric characters
Nesting user-defined function blocks	Not supported

### 6-5-3 Operation rights

Operation rights for user-defined function blocks include a password and activation key. Restrictions in user-defined function block operations are given below.

		Editable	Accessing and monitoring	Importing
Passwords	Editable	OK	OK	OK
	Read only	---	OK	OK
Activation key		---	---	OK

An activation key is used to prevent unintentional importing of user-defined function blocks.

To set operation rights, right-click the function block that you created in the Project Window. Operation rights can also be set when creating a new user-defined function block.

### 6-5-4 Creating User-defined Function Blocks

- 1,2,3... 1. Right-click User-defined Function Blocks in the Project Window and select **New User-defined Function Block**.

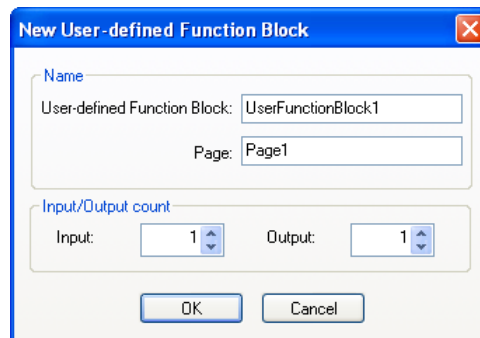

2. Enter the name of the user-defined function block, the name of the first page, and the number of inputs and outputs ("Input/Output count").
3. Click the **OK** Button.
4. A dialog box will be displayed to set the passwords. Set the editable password and read only password.  
A user-defined function block will be added under *User-defined Function Blocks* in the Project Window.



**Additional Information**

- The password must be between 6 and 16 alphanumeric characters. The following characters cannot be used in user-defined function block names:

\ / : \* ? " < > | % # .

- If the **OK** Button is clicked with no password set, the function block will not have a password and anyone can access and edit it.

5. Create the programming.  
Double-click the page in the user-defined function block and create the programming as usual by placing and connecting function blocks.
6. Save the user-defined function block.  
Select **User-defined Function Block - Save** from the File Menu.  
When a user-defined function block that is used in the program is edited and saved, the user-defined function blocks that are used in the program will change immediately.



**Additional Information**

Previously created programming can be converted to user-defined function blocks.

Procedure: Right-click the page to be converted to a function block under the Program folder in the Project Window and select **Register as User-defined Function Block**.

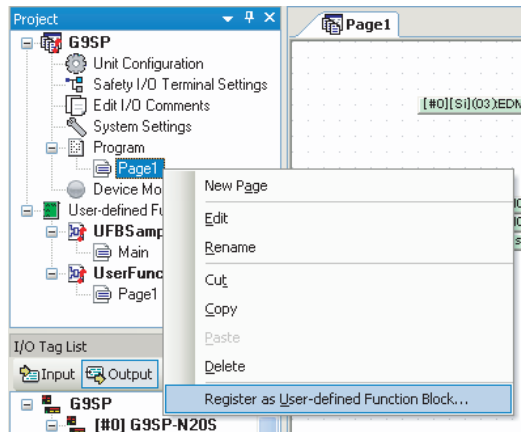

### 6-5-5 Exporting User-defined Function Blocks

User-defined function blocks can be exported and used in other project files.



**Precautions for Correct Use**

Test the operation of user-defined function blocks sufficiently before distributing them for application.

- 1,2,3... 1. Right-click the user-defined function block to export in the Project Window and select **Export**.

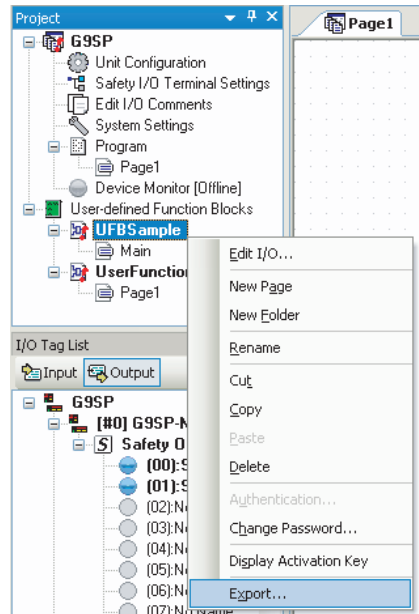

2. Select the location to export and click the Save Button.  
 3. The **Activation Key** Dialog Box will be displayed. Record the activation key and click the **OK** Button. The activation key is required to import the user-defined function block.

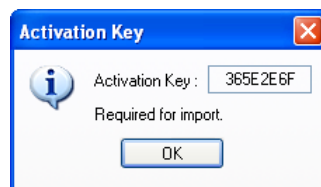

4. The definition is saved in a user-defined function block file (.udf).

### 6-5-6 Importing User-defined Function Blocks

User-defined function blocks from other project files can be imported.

- 1,2,3... 1. Right-click *User-defined Function Blocks* in the Project Window and select **Import**.

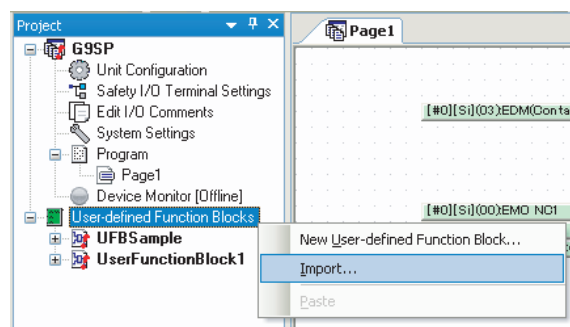

2. Select the user-defined function block file (.udf) to import and click the **Open** Button.



3. The **Input Authentication** Dialog Box will be displayed.  
Select the activation key of the user-defined function block to import and click the **OK** Button.  
You can also import the user-defined function block by entering the password.



4. The user-defined function block will be imported and displayed in the Project Window.



**SECTION 7**

**Communications with a Standard PLC Using an Option Board**

This section describes how to perform communications with a Standard PLC through an RS-232C Option Board or Ethernet Option Board.

7-1	Functionality for All Option Board's .....	94
7-1-1	Features.....	94
7-1-2	Application Examples.....	94
7-1-3	Transmission/Reception Data.....	96
7-2	RS-232C Serial Communications.....	105
7-2-1	Communications Format .....	105
7-2-2	Application Example .....	106
7-3	Ethernet Communications.....	112
7-3-1	Communications Format .....	112
7-3-2	Application Example .....	114

## 7-1 Functionality for All Option Board's

The G9SP-series Controller communicate with a Standard PLC through an RS-232C Serial Communications Board (CP1W-CIF01) or an Ethernet Communications Board (CP1W-CIF41).

This section provides examples of connections with an OMRON PLC. It gives the communications specifications and provides examples of applications for Option Board communications. Examples of connections to a PLC from another manufacturer are described in the *G9SP Host Connection Manual* (Cat. No. Z924).

### 7-1-1 Features

This section describes the features of the G9SP-series Controller's Option Board communications.

#### RS-232C Serial Communications and Ethernet Communications

Select from two types of communications according to the application. The use of no-protocol RS-232C serial communications and Ethernet UDP/IP enables communications with both non-OMRON Standard PLCs and OMRON PLCs. Communications with OMRON PLCs can be performed using the FINS/UDP protocol.

#### Easy Connection

Settings at the G9SP-series Controller are not required to use RS-232C serial communications. Only TCP/IP settings are required to use Ethernet communications. In addition, connection at the Standard PLC can be easily made by following the sample ladder programming and the setting examples in the following descriptions.

#### Wide Variety of Monitor Data

Monitoring can be performed for operation status with detailed information on any errors that occur in the G9SP-series Controller. In particular, for Safety I/O terminals, you can check the cause of an error, such as a short-circuit or ground fault to 24 V, rather than simply the number of the terminal at which the error occurred.

#### Input Data to G9SP-series Controller Program

Data received by the G9SP-series Controller can be used in the program.

### 7-1-2 Application Examples

#### Monitoring for Correct Operation of G9SP-series Controller

You can monitor whether the G9SP-series Controller is operating correctly by using the G9SP-series Controller's Unit Normal Operating Flag and Present Error Information. The Unit Normal Operating Flag turns ON when the Unit is operating in RUN Mode and no errors have occurred. When this flag is OFF, an error has probably occurred. Therefore, check the Present Error Information to identify the error in the G9SP-series Controller.

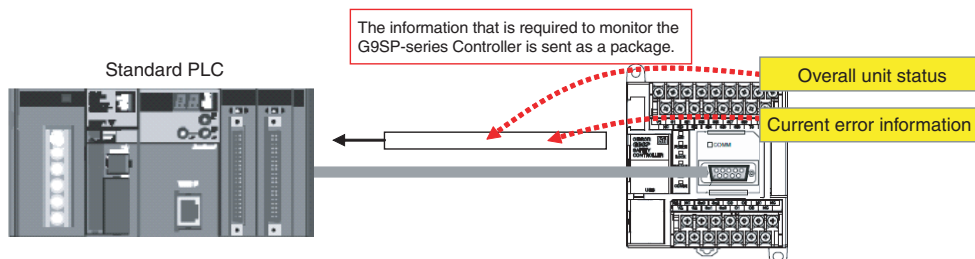

### Monitoring Safety I/O Terminal Status

You can monitor the status of the G9SP-series Controller's Safety I/O terminals by using the G9SP-series Controller's Safety I/O Terminal Data Flags, Safety I/O Terminal Status Flags, and Safety I/O Terminal Error Cause. A Safety I/O Terminal Data Flag indicates the ON/OFF status of the terminal, and a Safety I/O Terminal Status Flag indicates whether an error has occurred at the terminal (OFF when an error has occurred).

When an error has occurred, you can investigate the cause of the error by using the Safety I/O Terminal Error Cause. For example, the information will change as follows if an error occurs at Safety Output terminal So0.

Normal			Error Occurred		
Information on So0	Value	Meaning	Information on So0	Value	Meaning
Safety Output Terminal Data Flag	1	ON	Safety Output Terminal Data Flag	0	OFF
Safety Output Terminal Status Flag	1	Normal	Safety Output Terminal Status Flag	0	Error
Safety Output Terminal Error Cause	0	No error	Safety Output Terminal Error Cause	3	Short circuit to low

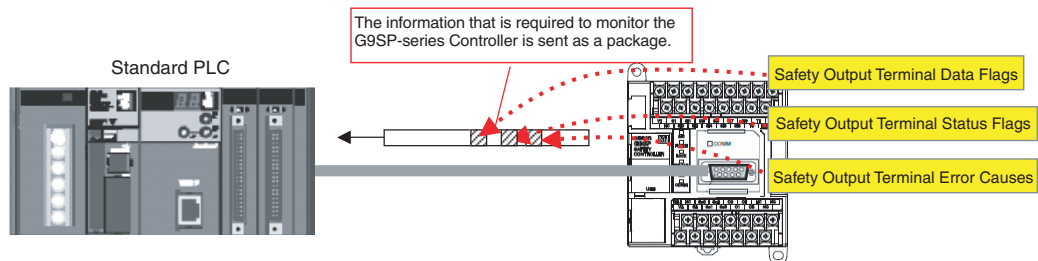

### Sending Operation Instructions to the G9SP-series Controller

Values can be written from a Standard PLC to the program of a G9SP-series Controller by using the communications data received by the G9SP-series Controller. This can be used in applications such as sending operation instructions to the safety system from a Standard PLC.

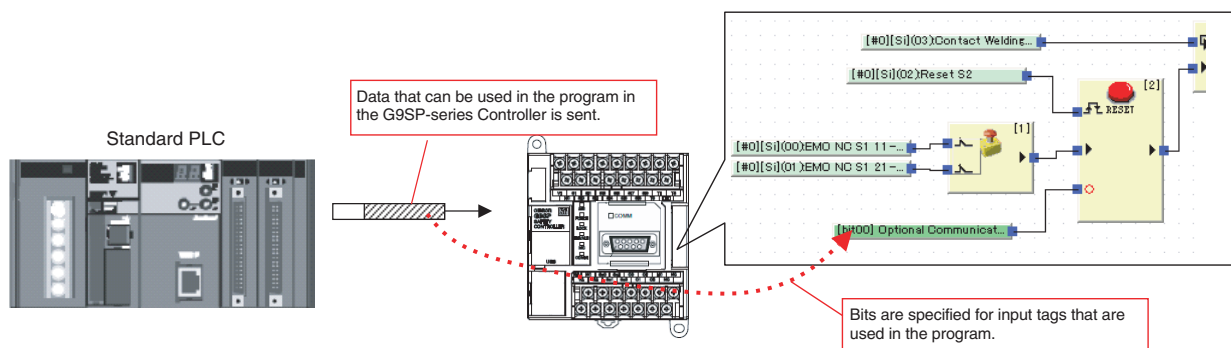

### 7-1-3 Transmission/Reception Data

This section describes the data that can be sent and received by the G9SP-series Controller. There is no difference in data specifications for RS-232C serial communications and Ethernet communications.

#### Reception Data (Standard PLC to G9SP-series Controller)

The format of the data component sent from a Standard PLC to the G9SP-series Controller is shown below.

+0	Optional Communications Reception Data	4 bytes
+4	Echo-back	2 bytes

#### Optional Communications Reception Data

	Bit 7	Bit 6	Bit 5	Bit 4	Bit 3	Bit 2	Bit 1	Bit 0
+0	Bit 07	Bit 06	Bit 05	Bit 04	Bit 03	Bit 02	Bit 01	Bit 00
+1	Bit 15	Bit 14	Bit 13	Bit 12	Bit 11	Bit 10	Bit 09	Bit 08
+2	Bit 23	Bit 22	Bit 21	Bit 20	Bit 19	Bit 18	Bit 17	Bit 16
+3	Bit 31	Bit 30	Bit 29	Bit 28	Bit 27	Bit 26	Bit 25	Bit 24

These 32 bits of data can be used in the program of the G9SP-series Controller. The data is displayed as *Optional Communications Reception Data* in the I/O Tag List.

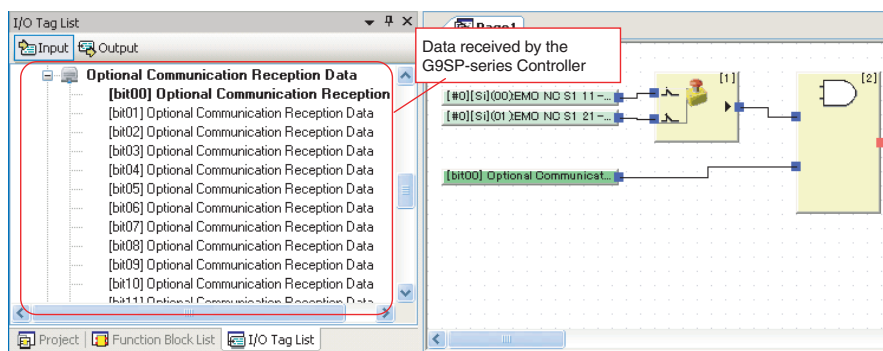

#### Echo-back

	Bit 7	Bit 6	Bit 5	Bit 4	Bit 3	Bit 2	Bit 1	Bit 0
+0	Echo-back	Reserved						
+1	Reserved							

The echo-back is used to check that communications have been established with the G9SP-series Controller. The G9SP-series Controller returns the echo-back value unchanged to the Standard PLC.

**Transmission Data (G9SP-series Controller to Standard PLC)**

The format of the data component sent to the PLC from the G9SP-series Controller is shown below.

+0	Optional Communications Transmission Data	4 bytes
+4	Safety Input Terminal Data Flags	6 bytes
+10	Safety Output Terminal Data Flags	4 bytes
+14	Safety Input Terminal Status Flags	6 bytes
+20	Safety Output Terminal Status Flags	4 bytes
+24	Safety Input Terminal Error Causes	24 bytes
+48	Safety Output Terminal Error Causes	16 bytes
+64	Reserved	2 bytes
+66	Unit Status and Echo-back	2 bytes
+68	Configuration ID	2 bytes
+70	Unit Conduction Time	4 bytes
+74	Reserved	20 bytes
+94	Present Error Information	12 bytes
+106	Error Log Count	1 byte
+107	Operation Log Count	1 byte
+108	Error Log	40 bytes
+148	Operation Log	40 bytes

**Optional Communications Transmission Data**

	Bit 7	Bit 6	Bit 5	Bit 4	Bit 3	Bit 2	Bit 1	Bit 0
+0	Bit 07	Bit 06	Bit 05	Bit 04	Bit 03	Bit 02	Bit 01	Bit 00
+1	Bit 15	Bit 14	Bit 13	Bit 12	Bit 11	Bit 10	Bit 09	Bit 08
+2	Bit 23	Bit 22	Bit 21	Bit 20	Bit 19	Bit 18	Bit 17	Bit 16
+3	Bit 31	Bit 30	Bit 29	Bit 28	Bit 27	Bit 26	Bit 25	Bit 24

These 32 bits of data can be used in the program of the G9SP-series Controller. The data is displayed as *Optional Communication Transmission Data* in the I/O Tag List.

**Safety Input Terminal Data Flags**

	Bit 7	Bit 6	Bit 5	Bit 4	Bit 3	Bit 2	Bit 1	Bit 0
+0	Si 07	Si 06	Si 05	Si 04	Si 03	Si 02	Si 01	Si 00
+1	Si 15	Si 14	Si 13	Si 12	Si 11	Si 10	Si 09	Si 08
+2	Reserved				Si 19	Si 18	Si 17	Si 16
+3	Reserved							
+4	Reserved							
+5	Reserved							

The flags show the ON/OFF values after self-diagnosis for the Safety Input terminals.

0: Input terminal OFF or error. 1: Input terminal ON.

**Safety Output Terminal Data Flags**

	Bit 7	Bit 6	Bit 5	Bit 4	Bit 3	Bit 2	Bit 1	Bit 0
+0	So 07	So 06	So 05	So 04	So 03	So 02	So 01	So 00
+1	So 15	So 14	So 13	So 12	So 11	So 10	So 09	So 08
+2	Reserved							
+3	Reserved							

The flags show the ON/OFF values monitored for Safety Output terminals.

0: Output terminal OFF.                      1: Output terminal ON.

**Safety Input Terminal Status Flags**

	Bit 7	Bit 6	Bit 5	Bit 4	Bit 3	Bit 2	Bit 1	Bit 0
+0	Si 07	Si 06	Si 05	Si 04	Si 03	Si 02	Si 01	Si 00
+1	Si 15	Si 14	Si 13	Si 12	Si 11	Si 10	Si 09	Si 08
+2	Reserved				Si 19	Si 18	Si 17	Si 16
+3	Reserved							
+4	Reserved							
+5	Reserved							

These flags are the normal status flags for self-diagnosis of the Safety Input terminals. They are used to monitor for Safety Input terminal errors, such as disconnected lines, ground fault, and short-circuit.

0: Error.    1: Normal operation (no error).

**Safety Output Terminal Status Flags**

	Bit 7	Bit 6	Bit 5	Bit 4	Bit 3	Bit 2	Bit 1	Bit 0
+0	So 07	So 06	So 05	So 04	So 03	So 02	So 01	So 00
+1	So 15	So 14	So 13	So 12	So 11	So 10	So 09	So 08
+2	Reserved							
+3	Reserved							

These flags are the normal status flags for self-diagnosis of the Safety Output terminals. They are used to monitor for Safety Output terminal errors, such as disconnected lines, ground fault, and short-circuit.

0: Error.    1: Normal operation (no error).



**Safety Input Terminal Error Causes**

	Bit 7	Bit 6	Bit 5	Bit 4	Bit 3	Bit 2	Bit 1	Bit 0
+0	Si 01				Si 00			
+1	Si 03				Si 02			
+2	Si 05				Si 04			
+3	Si 07				Si 06			
+4	Si 09				Si 08			
+5	Si 11				Si 10			
+6	Si 13				Si 12			
+7	Si 15				Si 14			
+8	Si 17				Si 16			
+9	Si 19				Si 18			
+10	Reserved							
---	---				---			
+23	Reserved							

This information provides details on the errors detected using self-diagnosis of the Safety Input terminals.

- 0: No error
- 1: Invalid configuration
- 2: External test signal failure
- 3: Internal circuit error
- 4: Discrepancy error
- 5: Failure of the associated dual-channel input

**Safety Output Terminal Error Causes**

	Bit 7	Bit 6	Bit 5	Bit 4	Bit 3	Bit 2	Bit 1	Bit 0
+0	So 01				So 00			
+1	So 03				So 02			
+2	So 05				So 04			
+3	So 07				So 06			
+4	So 09				So 08			
+5	So 11				So 10			
+6	So 13				So 12			
+7	So 15				So 14			
+8	So 17				So 16			
+9	So 19				So 18			
+10	Reserved							
---	---				---			
+15	Reserved							

This information provides details on the errors detected using self-diagnosis of the Safety Output terminals.

- 0: No error
- 1: Invalid configuration
- 2: Overcurrent detection
- 3: Short circuit detection
- 4: Stuck-at-high detection
- 5: Failure of the associated dual-channel output
- 6: Internal circuit error
- 8: Dual channel violation

**Unit Status and Echo-back**

	Bit 7	Bit 6	Bit 5	Bit 4	Bit 3	Bit 2	Bit 1	Bit 0
+0	Echo-back	Reserved	Reserved	Reserved	Reserved	Reserved	Reserved	Unit Normal Operating Flag
+1	Reserved	Reserved	Function Block Error Flag	Reserved	Reserved	Safety I/O Terminal Error Flag	Output Power Supply Error Flag	Reserved

These flags indicate the overall status of the G9SP-series Controller.

Status name	Meaning
Unit Normal Operating Flag	0: Error occurred or program stopped. 1: Normal status (no error) and program being executed.
Output Power Supply Error Flag	0: Output power supply voltage normal. 1: Output power supply voltage error or power supply OFF.
Safety I/O Terminal Error Flag	0: No error in Safety I/O terminals. 1: Error in Safety I/O terminals.
Function Block Error Flag	0: No error in any function block. 1: Error in a function block.

■ **Echo-back**

This is the echo-back value received from a Standard PLC.

**Configuration ID**

	Bit 7	Bit 6	Bit 5	Bit 4	Bit 3	Bit 2	Bit 1	Bit 0
+0	Configuration ID rightmost byte							
+1	Configuration ID leftmost byte							

**Unit Conduction Time**

	Bit 7	Bit 6	Bit 5	Bit 4	Bit 3	Bit 2	Bit 1	Bit 0
+0	Unit Conduction Time, first byte (rightmost byte)							
+1	Unit Conduction Time, second byte							
+2	Unit Conduction Time, third byte (leftmost byte)							
+3	Reserved							

This is the total time that the G9SP-series Controller has been ON and operating normally. The Unit Conduction Time is updated and saved every six minutes. The time is given in minutes.

For example, if the G9SP-series Controller has been ON for 100 days, 12 hours, and 12 minutes,  $100 \times 24 \times 60 + 12 \times 60 + 12 = 144,732$  (minutes) = 02355C hex (minutes). This data is stored as follows:

+0	5C
+1	35
+2	02
+3	00 (reserved)

**Present Error Information**

	Bit 7	Bit 6	Bit 5	Bit 4	Bit 3	Bit 2	Bit 1	Bit 0
+0	Error Information Map 0							
+1	Error Information Map 1							
---	---							
+11	Error Information Map 11							

The details of errors occurring in the G9SP-series Controller are displayed using a bit maps. Multiple bits turn ON if multiple errors have occurred. Refer to subsequent pages for error details and corresponding bit maps.

**Error Log Count**

	Bit 7	Bit 6	Bit 5	Bit 4	Bit 3	Bit 2	Bit 1	Bit 0
+0	Error Log Count							

This is the number of errors registered in the error log (0 to 10). Refer to 10-1-3 *Error Log* for information on the error log count.

**Operation Log Count**

	Bit 7	Bit 6	Bit 5	Bit 4	Bit 3	Bit 2	Bit 1	Bit 0
+0	Operation Log Count							

This is the number of operations registered in the log (0 to 10). Refer to 10-1-4 *Operation Log* for information on the operation log count.

**Error Log**

	Bit 7	Bit 6	Bit 5	Bit 4	Bit 3	Bit 2	Bit 1	Bit 0
+0	Error record 1 (most recent) error code							
+1	Error record 1 (most recent) Unit Conduction Time third byte at error							
+2	Error record 1 (most recent) Unit Conduction Time second byte at error							
+3	Error record 1 (most recent) Unit Conduction Time first byte at error							
---	---							
+36	Error record 10 (oldest) error code							
+37	Error record 10 (oldest) Unit Conduction Time third byte at error							
+38	Error record 10 (oldest) Unit Conduction Time second byte at error							
+39	Error record 10 (oldest) Unit Conduction Time first byte at error							

This is a log of recorded errors. The error details are given using the following error codes. The Unit Conduction Time is also stored when an error occurs.

■ Error Codes

Error code (hex)	Error description	Bit map in present error information	
		Map No.	Bit No.
05	Force mode timeout	Error Information Map 0	4
07	Invalid configuration	Error Information Map 0	6
08	System failure	Error Information Map 0	7
11	External test signal failure at Safety Input	Error Information Map 2	0
12	Internal circuit error at Safety Input	Error Information Map 2	1
13	Discrepancy error at Safety Input	Error Information Map 2	2
15	Overload detected at Test Output	Error Information Map 2	4
17	Stuck-at-high detected at Test Output	Error Information Map 2	6
18	Under current detected using Muting Lamp	Error Information Map 2	7
19	Over current detected at Safety Output	Error Information Map 3	0
1A	Short circuit detected at Safety Output	Error Information Map 3	1
1B	Stuck-at-high detected at Safety Output	Error Information Map 3	2
1C	Dual channel violation at Safety Output	Error Information Map 3	3
1D	Internal circuit error at Safety Output	Error Information Map 3	4
22	Output PS voltage low	Error Information Map 4	1
25	Output PS OFF circuit error	Error Information Map 4	4
26	Internal circuit error at Test Output	Error Information Map 4	5
33	Function block status error	Error Information Map 6	2
39	Internal NVS access error	Error Information Map 7	0
3A	Unsupported expansion I/O unit	Error Information Map 7	1
3B	Expansion I/O unit maximum connection number exceeded	Error Information Map 7	2
3C	Expansion I/O unit configuration mismatch	Error Information Map 7	3
3D	Expansion I/O bus error	Error Information Map 7	4
3E	Unsupported option board	Error Information Map 7	5
3F	Option board communications error, communications timeout	Error Information Map 7	6
40	Option board communications error, not mounted	Error Information Map 7	7
42	Memory cassette not inserted or incorrect memory cassette	Error Information Map 8	1
43	Memory cassette removed or access error	Error Information Map 8	2
44	Internal NVS access error during execution of memory cassette functions	Error Information Map 8	3
45	Restore model information mismatch	Error Information Map 8	4
46	Device password mismatch between restore memory cassette and unit	Error Information Map 8	5
47	Restore prohibit error	Error Information Map 8	6
48	Incorrect configuration data at restore	Error Information Map 8	7
49	Unconfigured unit at backup	Error Information Map 9	0
4A	Unlocked unit at backup error	Error Information Map 9	1

This section provides examples of values for present errors and the error log when the following errors occur.

Sequence of occurrence	Error description	Unit Conduction Time at error	Error status
1	Unsupported Option Board	0 day, 0 hours, 6 minutes = 000006 hex (minutes)	Cleared
2	Safety Input terminal error detected in dual-channel monitoring	100 days, 12 hours, 12 minutes = 02355C hex (minutes)	Error occurred
3	Output power supply voltage error	100 days, 12 hours, 18 minutes = 023562 hex (minutes)	Error occurred

Present Error		Value	Error Log		Value	
+0	Error Information Map 0	00 hex	+0	Record 1	Unit Conduction Time at error	22 hex
+1	Error Information Map 1	00 hex	+1			02 hex
+2	Error Information Map 2	04 hex	+2			35 hex
+3	Error Information Map 3	00 hex	+3			62 hex
+4	Error Information Map 4	02 hex	+4	Record 2	Error code	13 hex
+5	Error Information Map 5	00 hex	+5		Unit Conduction Time at error	02 hex
+6	Error Information Map 6	00 hex	+6			35 hex
+7	Error Information Map 7	00 hex	+7			5C hex
+8	Error Information Map 8	00 hex	+8	Record 3	Error code	3E hex
+9	Error Information Map 9	00 hex	+9		Unit Conduction Time at error	00 hex
+10	Error Information Map 10	00 hex	+10			00 hex
+11	Error Information Map 11	00 hex	+11			06 hex
			+12	Record 4 and higher		00 hex
			---			00 hex
			+39			00 hex

**Operation Log**

	Bit 7	Bit 6	Bit 5	Bit 4	Bit 3	Bit 2	Bit 1	Bit 0
+0	Operation record 1 (most recent) operation code							
+1	Operation record 1 (most recent) Unit Conduction Time third byte at operation							
+2	Operation record 1 (most recent) Unit Conduction Time second byte at operation							
+3	Operation record 1 (most recent) Unit Conduction Time first byte at operation							
---	---							
+36	Operation record 10 (oldest) operation code							
+37	Operation record 10 (oldest) Unit Conduction Time third byte at operation							
+38	Operation record 10 (oldest) Unit Conduction Time second byte at operation							
+39	Operation record 10 (oldest) Unit Conduction Time first byte at operation							

This is a log of recorded operations. The operation details are given using the following operation codes.

■ Operation Codes

Operation code (hex)	Operation description
01	Power ON or emulating cycling power
02	Out of box reset
04	Download
05	Lock/Unlock
06	Change Mode
07	Start/stop of force mode
08	Change device password
09	Clear error log
0A	Backup to Memory Cassette
0B	Restore from Memory Cassette

**Note** Refer to 7-2 *RS-232C Serial Communications* and 7-3 *Ethernet Communications* for examples of storing data to the memory of a Standard PLC.

## 7-2 RS-232C Serial Communications

This section provides a description and example of connection to an OMRON Standard PLC. No-protocol communications are used for connection with an OMRON Standard PLC.

### 7-2-1 Communications Format

#### Command Format (Standard PLC to G9SP-series Controller)

+0	Always 40 hex	1 byte
+1	Always 00 hex	1 byte
+2	Always 00 hex	1 byte
+3	Always 0F hex	1 byte
+4	Always 4B hex	1 byte
+5	Always 03 hex	1 byte
+6	Always 4D hex	1 byte
+7	Always 00 hex	1 byte
+8	Always 01 hex	1 byte
+9	Data	6 bytes
+15	Checksum (H)	2 bytes
+16	Checksum (L)	
+17	Always 2A hex	1 byte
+18	Always 0D hex	1 byte

Parameter	Description
Data	Refer to <i>Reception Data (Standard PLC to G9SP-series Controller)</i> in 7-1-3 <i>Transmission/Reception Data</i> .
Checksum	Checksum for bytes +0 to +16.

#### Response Format (G9SP-series Controller to Standard PLC)

+0	Always 40 hex	1 byte
+1	Response length (HL): Always 00 hex.	1 byte
+2	Response length (LH): Always 00 hex.	1 byte
+3	Response length (LL)	1 byte
+4	End code (H)	2 bytes
+5	End code (L)	
+6	Service code	1 byte
+7	Data	188 bytes
+195	Checksum (H)	2 bytes
+196	Checksum (L)	
+197	Always 2A hex	1 byte
+198	Always 0D hex	1 byte

Parameter	Description
Response length (LL)	Normal response: C3 hex Error response: 09 hex
End code	Correct command format: 0000 hex Incorrect command format, in which case there is no subsequent data: Not 0000 hex
Service code	Normal response: CB hex Error response: 94 hex
Data	Normal response: Refer to <i>Transmission Data (G9SP-series Controller to Standard PLC)</i> in 7-1-3 <i>Transmission/Reception Data</i> Error response: Two bytes of reserved data
Checksum	Checksum for bytes +0 to +194.

## 7-2-2 Application Example

### System Configuration

This section uses the following example to describe how to access a G9SP-series Controller by performing serial communications through a RS-232C Serial Communications Board (CP1W-CIF01) from a Standard PLC.

OMRON Standard PLC (See note.)

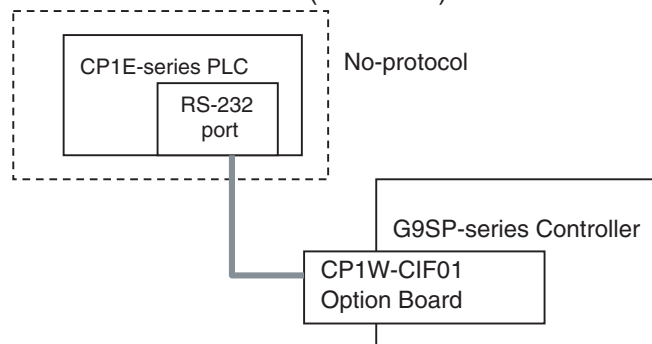

**Note** This example uses the following OMRON Standard PLC.

Product	Model/version
CPU Unit (Standard PLC)	CP1E-N40DR-A
Support Software (for setup and creating ladder programs)	CX-Programmer Ver. 9.10

### G9SP-series Controller Settings

Settings are not required. Make the communications settings in the OMRON Standard PLC to match the serial communications specifications of the G9SP-series Controller.



**OMRON PLC Settings**

Set serial port 1 as given below in the PLC Setup using the CX-Programmer.

Parameter	Description	Set value for this example
Baud rate	Serial port baud rate setting	9600, 8, 1, E
Mode	Communications protocol	RS-232C (no-protocol)
Start code	Send/receive data start code	0x0040
End code	Send/receive data end code	Reception bytes: 256

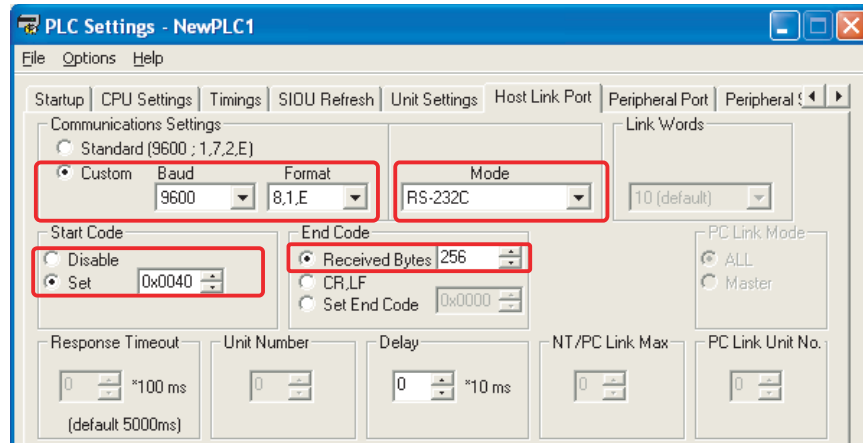

**Communications Cable**

Use the following cable connections to connect to an OMRON CP1E-series PLC as a Standard PLC.

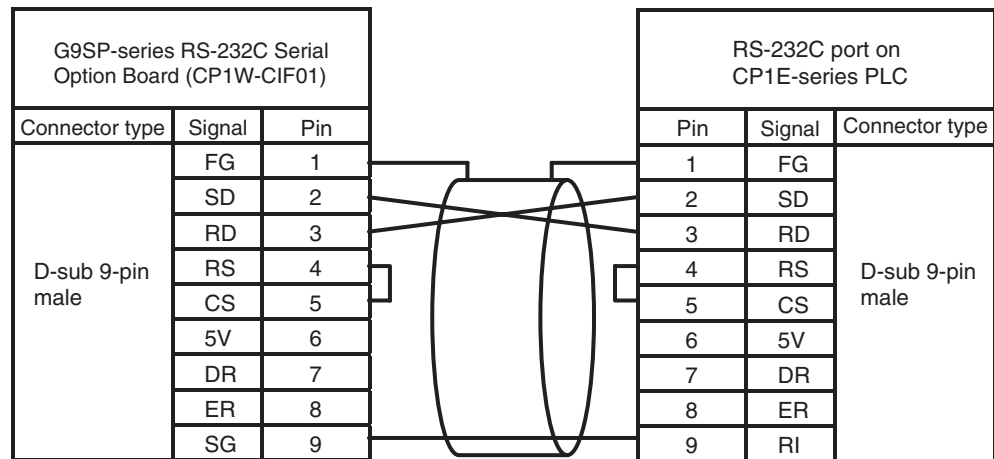

**Sample Ladder Programming for OMRON PLC**

This section provides an example of programming to monitor Safety Input terminal data of a G9SP-series Controller from an OMRON Standard PLC.

**RS-232C Serial Communications Sequence**

The G9SP-series Controller returns a response to the command sent from the Standard PLC.

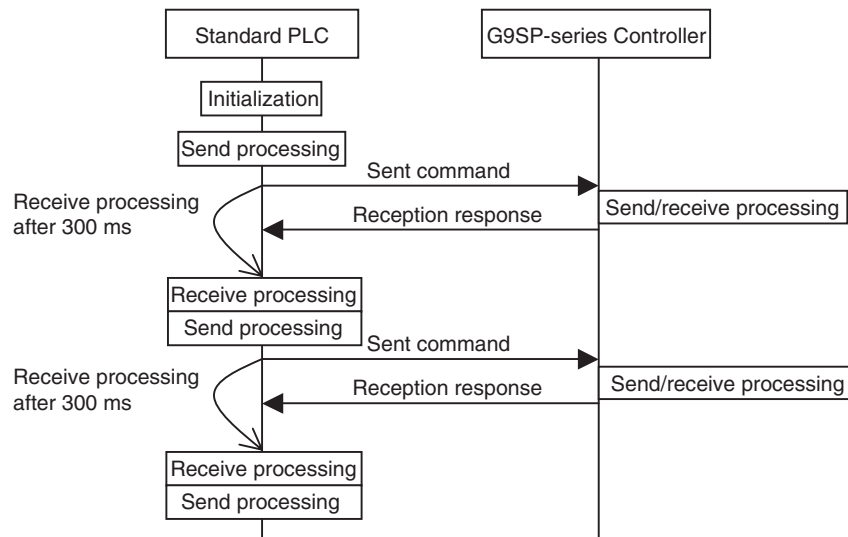

**OMRON PLC Memory Allocations**

Start address	End address	Contents	Description
D100	D108	RS-232C send command	Data sent by the Standard PLC to the G9SP-series Controller
D200	D298	RS-232C reception response	Data received by the Standard PLC from the G9SP-series Controller
D323		Reception size work area	Work area for RS-232C communications. Used to temporarily save the size of received data and to calculate the checksum
D300	D333	Checksum calculation work area	
CIO 100	CIO 101	G9SP communications reception data (written to G9SP-series Controller)	Data written to G9SP-series Controller from Standard PLC. Stored in the communications reception data of the G9SP-series Controller. (Refer to 7-1-3 Transmission/Reception Data.)
CIO 200	CIO 201	G9SP communications transmission data (read from the G9SP-series Controller)	Communications data sent from the G9SP-series Controller is read. (Refer to 7-1-3 Transmission/Reception Data.)
CIO 202	CIO 204	G9SP Safety Input terminal data (read from the G9SP-series Controller)	Safety Input terminal data of the G9SP-series Controller is read. (Refer to 7-1-3 Transmission/Reception Data.)

■ **G9SP Communications Reception Data**

	15					8					7					0				
CIO 100	Bit 15	Bit 14	Bit 13	Bit 12	Bit 11	Bit 10	Bit 09	Bit 08	Bit 07	Bit 06	Bit 05	Bit 04	Bit 03	Bit 02	Bit 01	Bit 00				
CIO 101	Bit 31	Bit 30	Bit 29	Bit 28	Bit 27	Bit 26	Bit 25	Bit 24	Bit 23	Bit 22	Bit 21	Bit 20	Bit 19	Bit 18	Bit 17	Bit 16				

■ **G9SP Communications Transmission Data**

	15					8					7					0				
CIO 200	Bit 15	Bit 14	Bit 13	Bit 12	Bit 11	Bit 10	Bit 09	Bit 08	Bit 07	Bit 06	Bit 05	Bit 04	Bit 03	Bit 02	Bit 01	Bit 00				
CIO 201	Bit 31	Bit 30	Bit 29	Bit 28	Bit 27	Bit 26	Bit 25	Bit 24	Bit 23	Bit 22	Bit 21	Bit 20	Bit 19	Bit 18	Bit 17	Bit 16				

■ **G9SP Safety Input Terminal Data**

	15					8					7					0				
CIO 202	Bit 15	Bit 14	Bit 13	Bit 12	Bit 11	Bit 10	Bit 09	Bit 08	Bit 07	Bit 06	Bit 05	Bit 04	Bit 03	Bit 02	Bit 01	Bit 00				
CIO 203	Reserved												Bit 19	Bit 18	Bit 17	Bit 16				
CIO 204	Reserved																			

Byte swapping (i.e., SWAP instruction) of data for each channel is required when the above data stored in the CIO Area is sent to or received from the G9SP-series Controller.

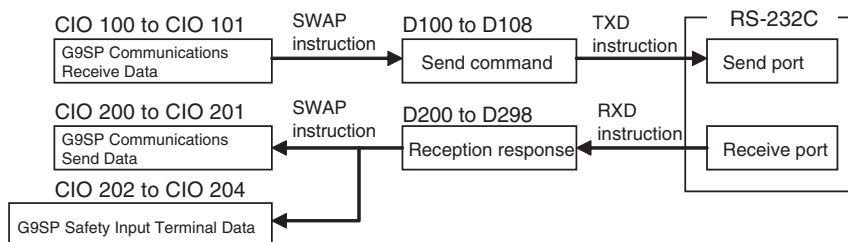

Sample Ladder Programming

■ From Initial Settings to Cyclic Send/Receive

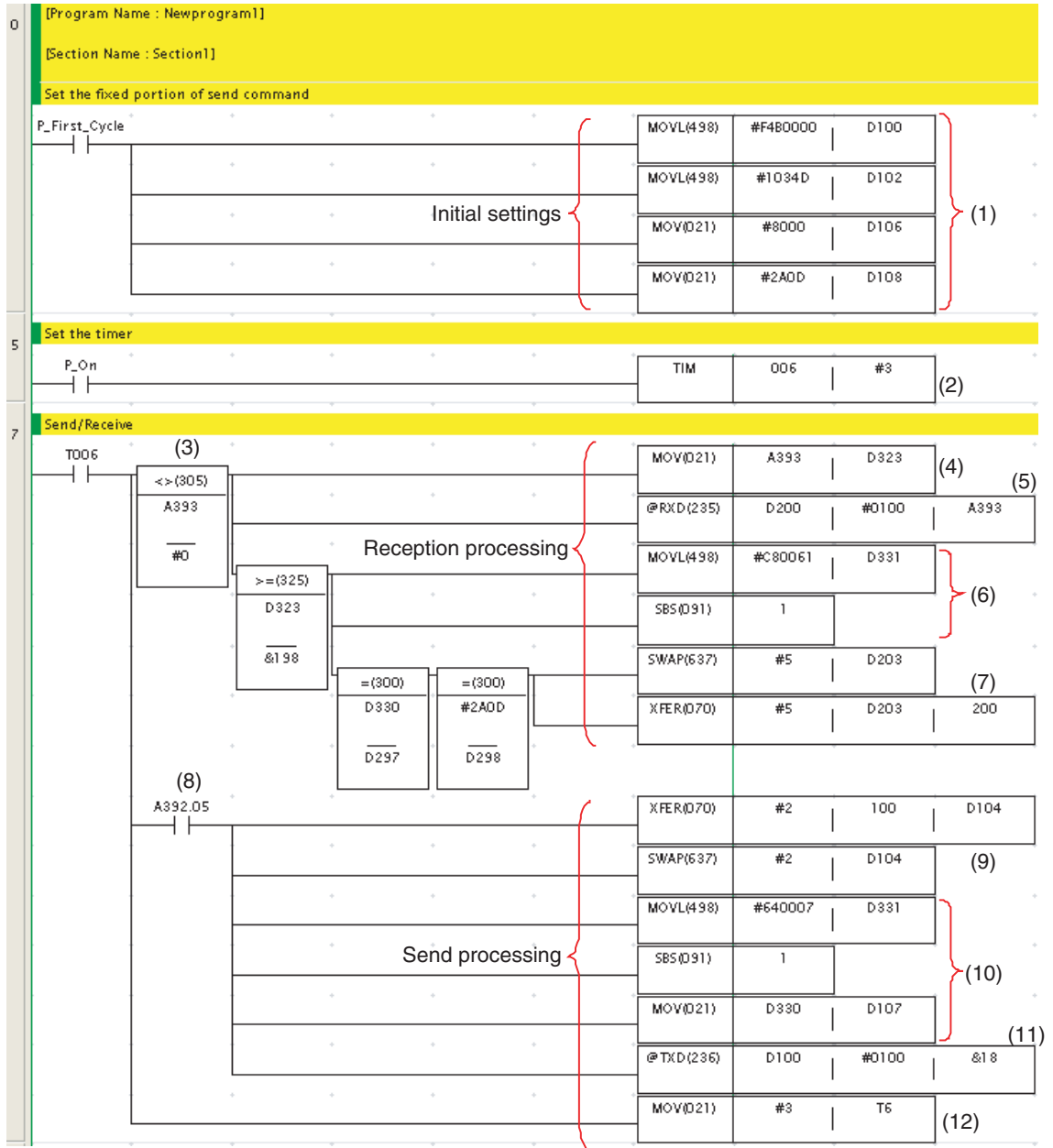

■ Checksum Calculation Subroutine

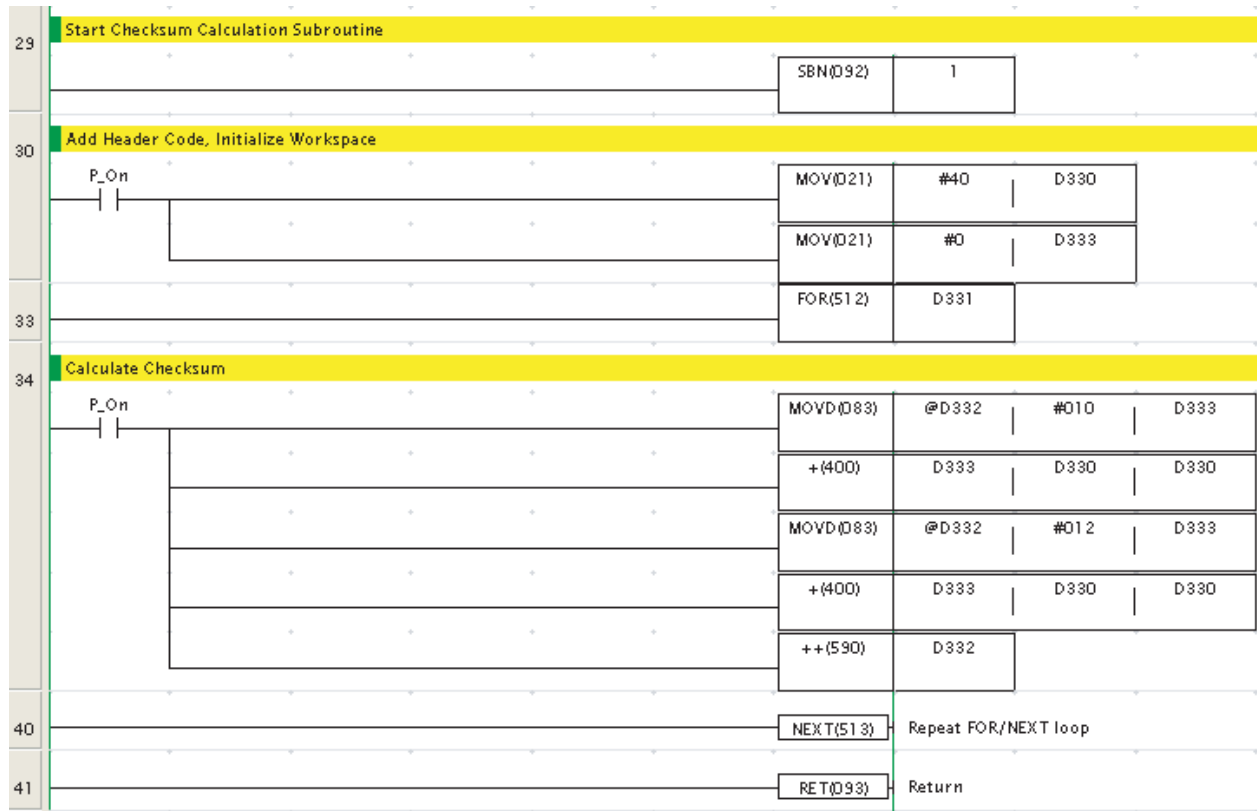

Step	Description
1	The fixed portion of the send command is set. This processing is performed once at startup. <b>Note</b> The start code at the beginning of the command format does not need to be set here. The value that is set in the PLC Setup will be sent.
2	A communications refresh timer of 300 ms is started. This performs the first sending after 300 ms.
3	Once 300 ms has elapsed, the RS-232C reception size (A393) is checked, and receive processing is performed if data has been received. A send command from the Standard PLC is initially required, and so reception processing is performed after completing the first send.
4	The RS-232C reception size is temporarily stored in D323 in the work area.
5	The reception response is read to D200 and following words from the RS-232C receive port.
6	The checksum calculation subroutine given above is called, and the checksum of the reception response is calculated.
7	The checksum of the reception response and the end code are checked, and the G9SP Communications Transmission Data is copied to CIO 200 and CIO 201 and G9SP Safety Input Terminal Data is copied to CIO 202 to CIO 204.
8	The system checks whether the RS-232C send port status is ready to send.
9	If sending is possible, G9SP communications reception data is set to the send command from CIO 100.
10	The checksum calculation subroutine given above is called, and the checksum of the send command is calculated.
11	The send command is transferred to the RS-232C send port, which enables sending to the G9SP-series Controller.
12	The timer is restarted and the next receive processing is performed after 300 ms.

## 7-3 Ethernet Communications

This section provides a description and example of connection to an OMRON Standard PLC. Connection can be performed to an OMRON Standard PLC using the FINS/UDP protocol.

**Note** Only CP1W-CIF41 Ethernet Option Boards with unit version 2.0 or later can be used. If another Option Board is used, the G9SP-series Controller will detect an Unsupported Option Board Error (the MS indicator will flash red).

### 7-3-1 Communications Format

#### Command Format (Standard PLC to G9SP-series Controller)

+0	Always 80 hex	1 byte
+1	Always 00 hex	1 byte
+2	Always 02 hex	1 byte
+3	Always 00 hex	1 byte
+4	FINS node address of G9SP-series Controller	1 byte
+5	Always 00 hex	1 byte
+6	Always 00 hex	1 byte
+7	FINS node address of Standard PLC	1 byte
+8	Unit number of Communications Unit in Standard PLC	1 byte
+9	Service ID	1 byte
+10	Always 28 hex	1 byte
+11	Always 01 hex	1 byte
+12	Always 00 hex	1 byte
+13	Always 4B hex	1 byte
+14	Always 03 hex	1 byte
+15	Always 4D hex	1 byte
+16	Always 00 hex	1 byte
+17	Always 01 hex	1 byte
+18	Data	6 bytes

Parameter	Description
FINS node address of G9SP-series Controller	Set the FINS node address that was set for the G9SP-series Controller. Refer to <i>G9SP-series Controller Settings</i> in 7-2-2 <i>Application Example</i> .
FINS node address of Standard PLC	Set the FINS node address that was set for the Standard PLC. Refer to <i>G9SP-series Controller Settings</i> in 7-2-2 <i>Application Example</i> .
Unit number of Communications Unit in Standard PLC	Specify the unit number that is set in the Communications Unit.
Service ID	Specify any value between 00 and FF hex.
Data	Refer to <i>Reception Data (Standard PLC to G9SP-series Controller)</i> in 7-1-3 <i>Transmission/Reception Data</i> .

**Response Format (G9SP-series Controller to Standard PLC)**

+0	Always C0 hex	1 byte
+1	Always 00 hex	1 byte
+2	Always 02 hex	1 byte
+3	Always 00 hex	1 byte
+4	FINS node address of Standard PLC	1 byte
+5	Always 00 hex	1 byte
+6	Always 00 hex	1 byte
+7	FINS node address of G9SP-series Controller	1 byte
+8	Unit number of Communications Unit in Standard PLC	1 byte
+9	Service ID	1 byte
+10	Always 28 hex	1 byte
+11	Always 01 hex	1 byte
+12	End code (H)	2 bytes
+13	End code (L)	
+14	Number of receive bytes (H)	2 bytes
+15	Number of receive bytes (L)	
+16	Always 00 hex	1 byte
+17	Service code	1 byte
+18	Data	188 bytes

Parameter	Description
FINS node address of Standard PLC	The FINS node address that was set for the Standard PLC is stored.
FINS node address of G9SP-series Controller	The FINS node address that was set for the G9SP-series Controller is stored.
Unit number of Communications Unit in Standard PLC	Set the unit number that is set in the Communications Unit.
Service ID	The service ID that was set in the command format is stored.
End code	Normal command format: 0000 hex Error command format, in which case there is no subsequent data: Not 0000 hex
Number of receive bytes	Normal command format: 00BE hex Error command format: 0004 hex
Service code	Normal response: CB hex Error response: 94 hex
Data	Normal response: Refer to <i>Transmission Data (G9SP-series Controller to Standard PLC)</i> in 7-1-3 <i>Transmission/Reception Data</i> Error response: Two bytes of reserved data

## 7-3-2 Application Example

### System Configuration

This section uses the following example to describe how to access the G9SP-series Controller from a Standard PLC by performing Ethernet communications through an Ethernet Communications Board (CP1W-CIF41).

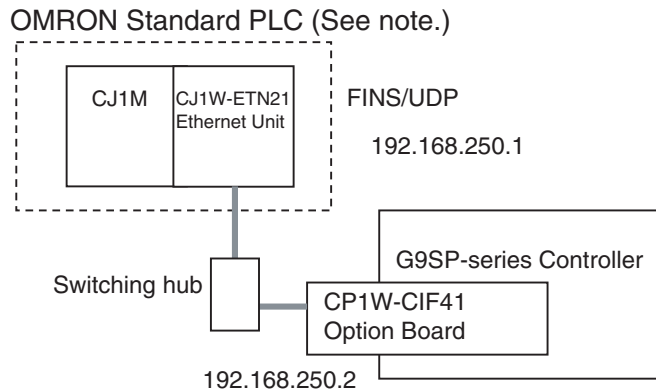

**Note** This example uses the following OMRON Standard PLC.

Product	Model/version
CPU Unit (Standard PLC)	CJ1M-CPU11
Ethernet Communications Unit	CJ1W-ETN21
Switching hub	W4S1-05B
Support Software (for setup and creating ladder programs)	CX-Programmer Ver. 9.10

### G9SP-series Controller Settings

Make the settings for TCP/IP in the system settings of the G9SP Configurator. These settings are set in the G9SP-series Controller and Ethernet Option Board when the configuration data is downloaded.

Parameter	Description	Set value for this example
IP address	IP address of Ethernet Option Board. Default value: 192.168.250.1	192.168.250.2
Subnet mask	Subnet mask of Ethernet Option Board. Default value: 255.255.255.0	No change is required.
Default gateway	Set the IP address of the default gateway. Default value: 0.0.0.0 (IP routing not supported)	No change is required.
FINS node address	Set the FINS node address of the Ethernet Option Board. If automatic setting is specified, a value that matches the rightmost byte of the IP address is stored. Default value: Automatic (matching the rightmost byte of the IP address) Setting range: 1 to 254	No change is required.



Parameter	Description	Set value for this example
FINS/UDP port	Specify the UDP port number that is specified in the FINS communications service. The UDP port number is a number used by UDP to identify the application layer (here, the FINS communications service). Default value: 0 (9600) Setting range: 0 to 65535. When set to 0, the FINS/UDP port number is 9600.	No change is required.
IP address table	Set the table that defines correspondence between the FINS node address and IP address at the Standard PLC. Set the IP address table when IP routing is used.	No change is required.

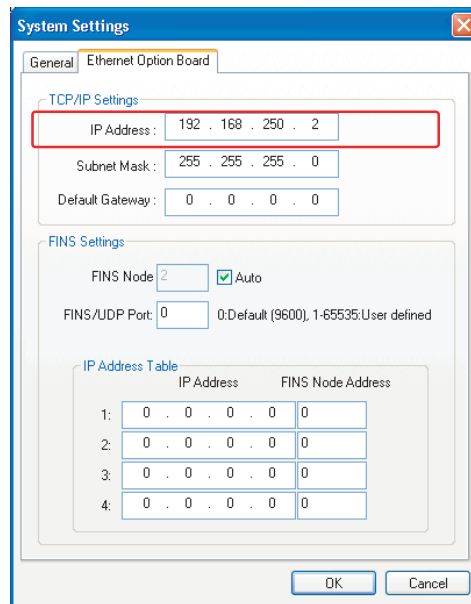

**OMRON PLC Settings**

Set the Ethernet port as shown below in the PLC Setup using the CX-Programmer.

Parameter	Description	Set value for this example
IP address	IP address of the CJ1W-ETN21	192.168.250.1
Subnet mask	Subnet mask of the CJ1W-ETN21	255.255.255.0

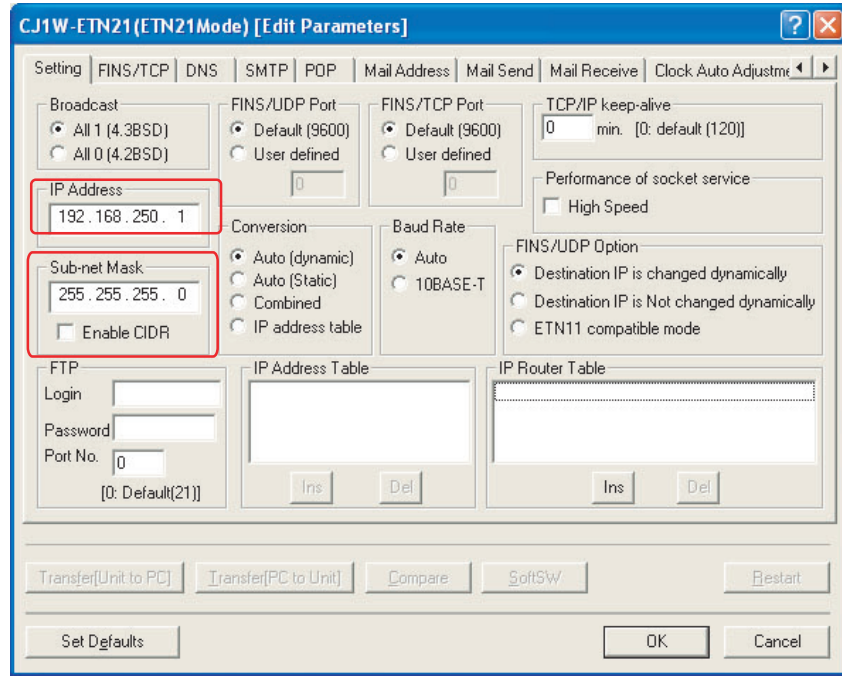

**Sample Ladder Programming for OMRON PLC**

This section provides an example of programming to monitor Safety Input terminal data of a G9SP-series Controller from an OMRON Standard PLC.

**Ethernet Communications Sequence**

The G9SP-series Controller returns a response to the command sent from the Standard PLC.

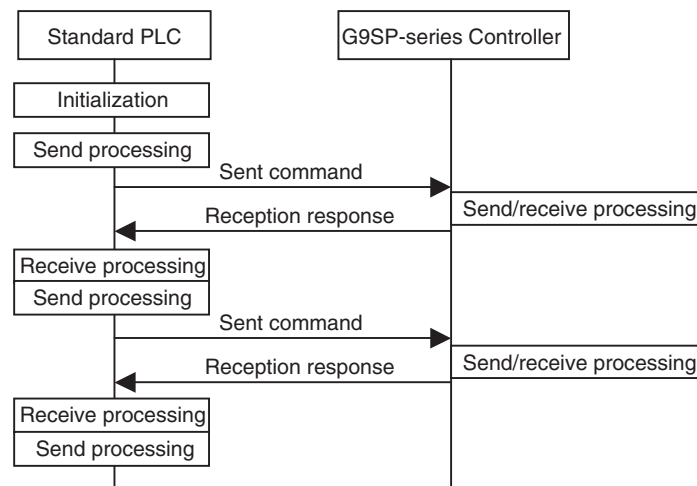

**OMRON PLC Memory Allocations**

Start address	End address	Contents	Description
D100	D108	Ethernet send command	Data sent by the Standard PLC to the G9SP-series Controller
D200	D298	Ethernet reception response	Data received by the Standard PLC from the G9SP-series Controller
D300	D305	CMND instruction control data	Control data for the CMND instruction is stored.
CIO 100	CIO 101	G9SP communications reception data (written to G9SP-series Controller)	Data written to G9SP-series Controller from Standard PLC. Stored in the communications reception data of the G9SP-series Controller. (Refer to 7-1-3 Transmission/Reception Data.)
CIO 200	CIO 201	G9SP communications transmission data (read from the G9SP-series Controller)	Communications data sent from the G9SP-series Controller is read. (Refer to 7-1-3 Transmission/Reception Data.)
CIO 202	CIO 204	G9SP Safety Input terminal data (read from the G9SP-series Controller)	Safety Input terminal data of the G9SP-series Controller is read. (Refer to 7-1-3 Transmission/Reception Data.)

■ **G9SP Communications Reception Data**

	15					8					7					0				
CIO 100	Bit 15	Bit 14	Bit 13	Bit 12	Bit 11	Bit 10	Bit 09	Bit 08	Bit 07	Bit 06	Bit 05	Bit 04	Bit 03	Bit 02	Bit 01	Bit 00				
CIO 101	Bit 31	Bit 30	Bit 29	Bit 28	Bit 27	Bit 26	Bit 25	Bit 24	Bit 23	Bit 22	Bit 21	Bit 20	Bit 19	Bit 18	Bit 17	Bit 16				

■ **G9SP Communications Transmission Data**

	15					8					7					0				
CIO 200	Bit 15	Bit 14	Bit 13	Bit 12	Bit 11	Bit 10	Bit 09	Bit 08	Bit 07	Bit 06	Bit 05	Bit 04	Bit 03	Bit 02	Bit 01	Bit 00				
CIO 201	Bit 31	Bit 30	Bit 29	Bit 28	Bit 27	Bit 26	Bit 25	Bit 24	Bit 23	Bit 22	Bit 21	Bit 20	Bit 19	Bit 18	Bit 17	Bit 16				

■ **G9SP Safety Input Terminal Data**

	15					8					7					0				
CIO 202	Bit 15	Bit 14	Bit 13	Bit 12	Bit 11	Bit 10	Bit 09	Bit 08	Bit 07	Bit 06	Bit 05	Bit 04	Bit 03	Bit 02	Bit 01	Bit 00				
CIO 203	Reserved												Bit 19	Bit 18	Bit 17	Bit 16				
CIO 204	Reserved																			

Byte swapping (i.e., SWAP instruction) of data for each channel is required when the above data stored in the CIO Area is sent to or received from the G9SP-series Controller.

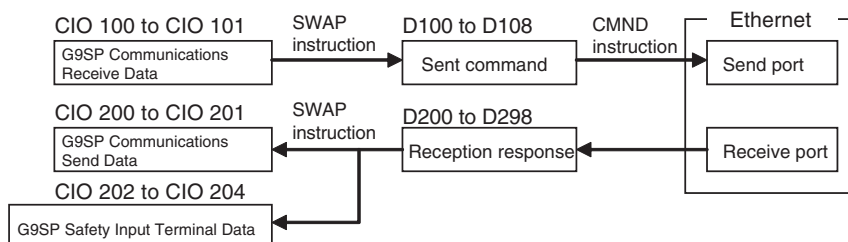

Sample Ladder Programming

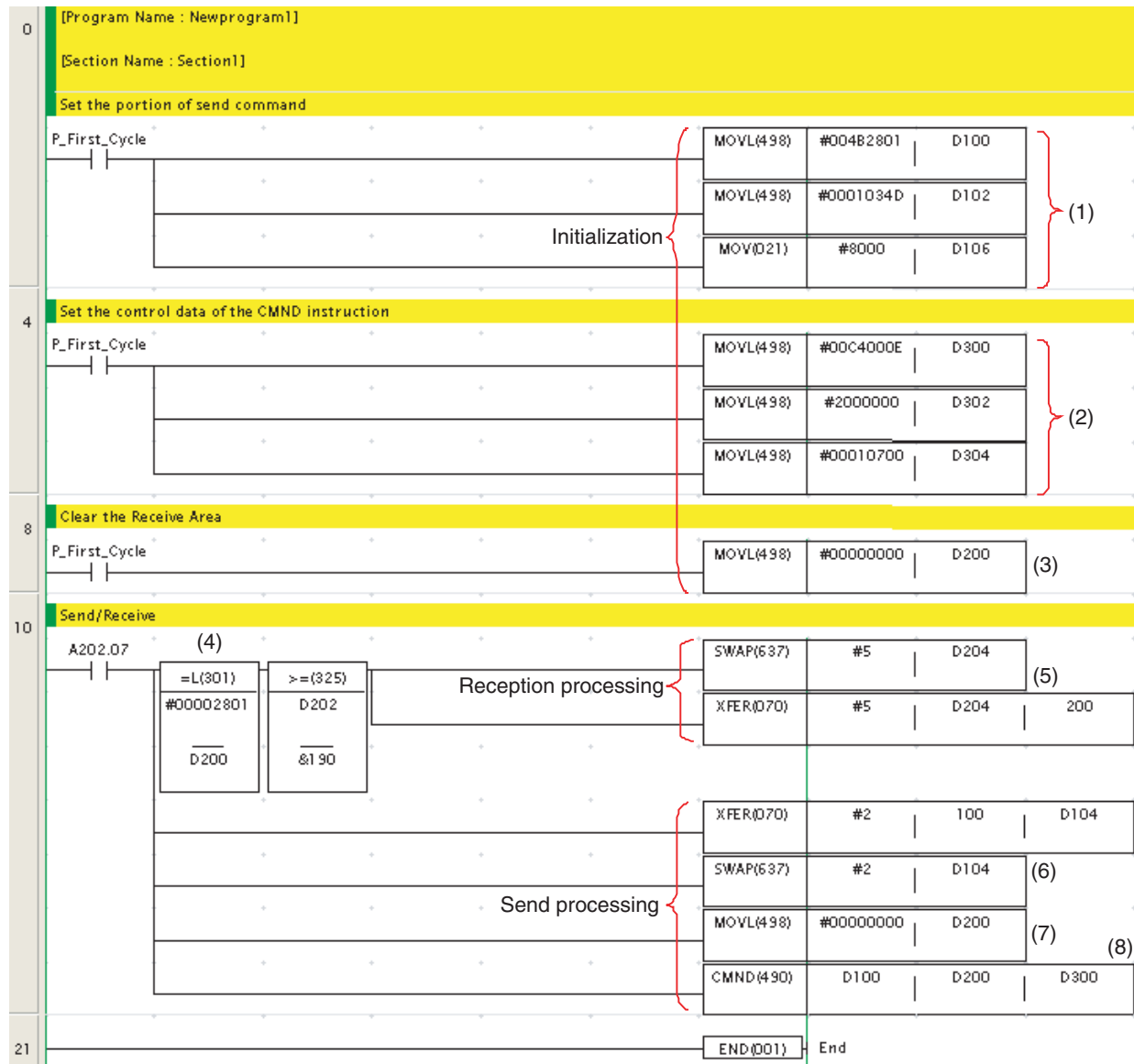

Step	Description
1	The fixed portion of the send command is set. This processing is performed once at startup.
2	Set the control data of the CMND instruction.
3	Clear the receive area in preparation for the first reception.
4	Once the data has been stored in the cleared receive area, check the size, and then start receive processing.
5	From the response, copy the G9SP Communications Transmission Data to CIO 200 and CIO 201 and the G9SP Safety Input Terminal Data to CIO 202 to CIO 204.
6	Once receive processing has been completed, set G9SP Communications Reception Data to the send command from CIO 100.
7	Clear the receive area in preparation for the next reception.
8	The send command is sent to the Ethernet send port, which enables sending to the G9SP-series Controller.

# SECTION 8

## Connecting Online and Downloading to the G9SP-series Controller

This section describes how to connect the G9SP-series Controller online to the computer and download the configuration data to the G9SP-series Controller.

8-1	Overview . . . . .	120
8-2	Downloading Configuration Data to the G9SP-series Controller and Verification	121
8-2-1	Connecting Online . . . . .	121
8-2-2	Downloading to G9SP-series Controller . . . . .	121
8-2-3	Verifying the Configuration Data . . . . .	122
8-3	Uploading Data from the G9SP-series Controller . . . . .	123
8-4	Resetting the G9SP-series Controller . . . . .	124
8-5	Setting a Device Password . . . . .	125

## 8-1 Overview

The configuration data that was created in *SECTION 6 Creating Configuration Data* is downloaded to the G9SP-series Controller. The G9SP-series Controller is then changed to RUN Mode so that the operation of the G9SP System can be verified.

The G9SP Configurator is connected online to the G9SP-series Controller to download the data, change to RUN Mode, and verify operation.

### **Basic Procedure to Prepare for Operation**

Basically, preparations for operation with the G9SP-series Controller are performed with the following procedure.

1. Connect the G9SP Configurator online to the G9SP-series Controller.
2. Download the configuration data to the G9SP-series Controller.
3. Verify the configuration data.
4. Change to RUN Mode. (Refer to *SECTION 9 Operation and Operating Modes*.)
5. Check operating status and debugging. (Refer to *SECTION 10 Checking Operating Status and Debugging*.)
6. Perform safety validation testing (user testing). (Refer to *SECTION 10 Checking Operating Status and Debugging*.)
7. Lock the configuration data. (Refer to *SECTION 9 Operation and Operating Modes*.)

This section describes steps 1 to 3, as well as the following online operations.

#### ■ **Uploading Data from the G9SP-series Controller**

The final configuration data can be read from the G9SP-series Controller.

#### ■ **Resetting**

The G9SP-series Controller can be restarted or the configuration data can be deleted and the G9SP-series Controller returned to the default status.

#### ■ **Setting a Device Password**

A Device Password can be set to prevent unapproved access to the G9SP-series Controller, including changes to the configuration data and changing the modes.

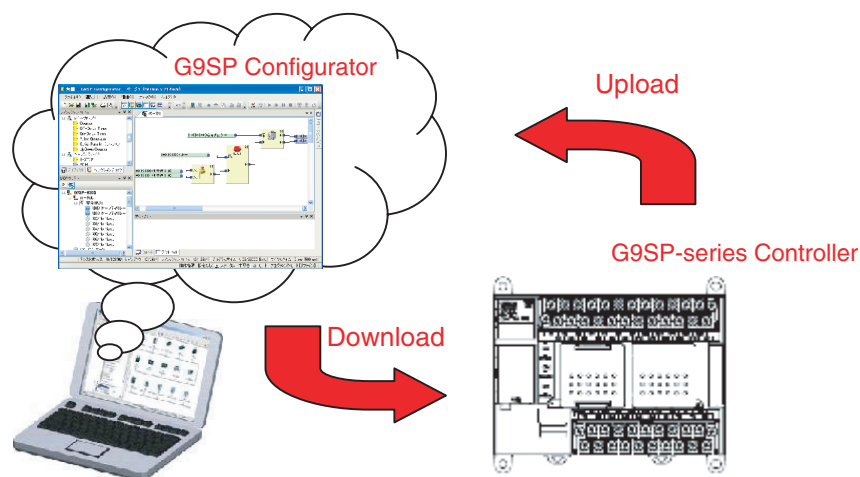

## 8-2 Downloading Configuration Data to the G9SP-series Controller and Verification

This section provides the procedure to place the G9SP Configurator online and download configuration data to the G9SP-series Controller.

### 8-2-1 Connecting Online

#### Procedure

When an online connection is established, communications between the G9SP Configurator and G9SP-series Controller will start.

- 1,2,3... 1. Click the Connect Icon (  ).



2. If the  icon changes as shown below, communications have been started.



### 8-2-2 Downloading to G9SP-series Controller

#### Procedure

After the online connection has been established, there are two ways to download configuration data to the G9SP-series Controller, as shown below.

- 1,2,3... 1. Click the Download Icon (  ).



2. Input the Device Password when prompted. If a device password is not set, do not input anything.
3. If a display appears saying that the download was successful, the download was completed normally.



#### Precautions for Correct Use

The configuration data cannot be downloaded while a Memory Cassette is inserted in the G9SP-series Controller. If necessary, remove the Memory Cassette, restart the G9SP-series Controller, and then download the data.

### 8-2-3 Verifying the Configuration Data

After the download has been completed, a verification is performed to check that the configuration data that was created has been correctly downloaded to the G9SP-series Controller. If the verification confirms that the configuration is correct, a report created from data uploaded from the G9SP-series Controller will be displayed.

Verified configurations will be indicated by *Verified* displayed at the lower right center on the G9SP Configurator.



#### Precautions for Safe Use

Be sure to use the report that is displayed after the verification has finished to check that the configuration that was created matches the configuration that was downloaded.

### Verification Procedure

- 1,2,3... 1. Click the Verify Icon (  ).



2. A verification report will be created if a message appears saying that no differences were found in the parameters.
3. Check the contents of the report, and then click the **Save** Button.
4. A message will ask if it is OK to mark the device for a verified configuration. Click the **Yes** Button, and the icon will change to *Verified*.



#### Additional Information

- To continue by checking I/O wiring or operating status, refer to the following sections.  
 Checking I/O wiring → 10-3 *Debugging in Force Mode*.  
 Checking operating status → 9-2 *Changing the Operating Mode*.
- After verifying project files for which safety validation testing (user testing) was performed, you can also lock the configuration data. Refer to 9-3 *Configuration Lock and Automatic Operation* for information on locking the configuration data.



## 8-3 Uploading Data from the G9SP-series Controller

The final configuration data in the G9SP-series Controller can be uploaded and restored to the G9SP Configurator.

### Procedure

- 1,2,3... 1. Connect online and then click the Upload Icon (  ).



2. If a parameter password has been set for the configuration data in the G9SP-series Controller, a dialog box to input the password will appear after reading the data has been completed. If this dialog box appears, enter the parameter password.

This step is not required if a parameter password has not been set.

3. If the upload is completed successfully, the configuration data will be displayed on the G9SP Configurator. If the parameter password that was entered in step 2 is not correct, the data will be uploaded, but operation will be restricted.



### Additional Information

---

A parameter password can be set to prevent reproducing the configuration data uploaded from the G9SP-series Controller so that programming know-how is not disclosed. (Refer to *6-3 Designing Device Security*.)

---

## 8-4 Resetting the G9SP-series Controller

The G9SP Configurator can reset the G9SP-series Controller in the following two ways. A password is required to execute the reset.

### Reset Types

Reset type	Configuration data	MS indicator	Error log/operation log	Unit Conduction Time
Emulate cycling power	Settings before the reset are retained.	Same as before reset.	Log before the reset is retained.	Values before reset are retained.
Return to the out-of-box configuration, and then emulate cycling power. (Initialize all data.)	Initialization (Default)	Flashing red and green. (Waiting for configuration.)	Log before the reset is retained.	Values before reset are retained.

The configuration data includes hardware settings, such as I/O terminal settings as well as the program and system settings.

The G9SP-series Controller stores this data in nonvolatile memory. Some information, however, cannot be changed once it is set without resetting the G9SP-series Controller. Select *Return to the out-of-box configuration, and then emulate cycling power* to return the information to the default parameter settings.

### Reset Type and Controller Status

Depending on the reset type and the G9SP-series Controller status, resetting might not be possible. Refer to *9-3 Configuration Lock and Automatic Operation* for information on locking the configuration.

Reset type	G9SP-series Controller status	
	Configuration lock - LOCK indicator lit yellow.	Configuration lock - LOCK indicator flashing yellow or not lit.
Emulate cycling power	Able to reset	Able to reset
Return to the out-of-box configuration, and then emulate cycling power	Unable to reset	Able to reset

### Procedure for Resetting

- 1,2,3... 1. Go online and select *Reset* from the Communication Menu.
2. In the Device Reset Window, input the reset type and the Device Password.
3. If a display appears saying that the reset has been completed, the G9SP-series Controller has been reset.

## 8-5 Setting a Device Password

The G9SP-series Controller can record a Device Password in nonvolatile memory. The Device Password can be used to prevent unauthorized or unintentional access to the G9SP-series Controller from a person other than a user (i.e., a safety manager).

No Device Password is set by default; the user must register one. Use the G9SP Configurator to set or change the Device Password for the G9SP-series Controller.

### Scope of Access Control

The following operations require the user to enter a Device Password. The G9SP-series Controller will not perform the following operations unless the password is correct.

- Downloading the configuration
- Locking or unlocking the configuration
- Executing the Controller's reset service
- Changing the operating mode
- Changing the password

### Lost Device Password

Contact your OMRON representative if you lose the password that is set in the G9SP-series Controller. For details, refer to *Appendix B Using the Password Recovery Tool*.

### Procedure for Setting Device Password

- 1,2,3...
1. Go online and select **Change Device Password** from the Communication Menu.
  2. In the Change Password Window shown below, input the current password and the new password.

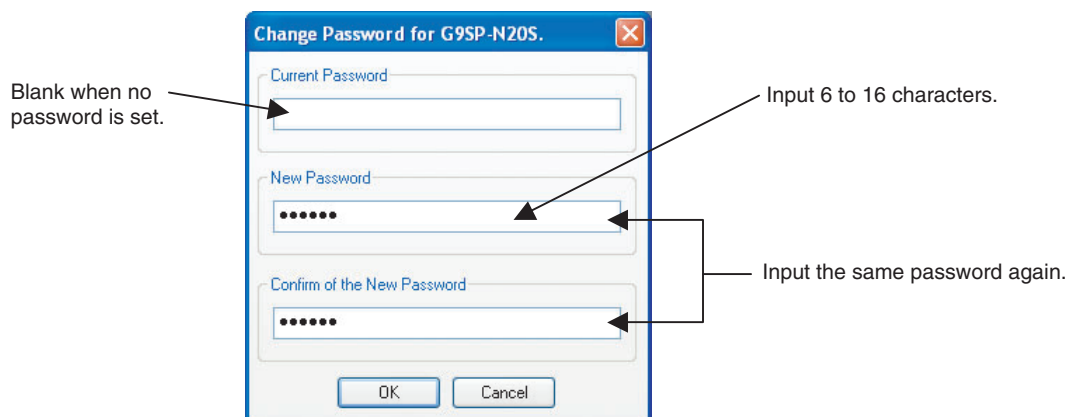

### **Additional Information**

For details on the Device Password, refer to *6-3 Designing Device Security*.



**SECTION 9**  
**Operation and Operating Modes**

This section describes how to switch the G9SP-series Controllers to RUN Mode.

9-1	G9SP-series Controller Operating Modes. . . . .	128
9-2	Changing the Operating Mode . . . . .	130
9-3	Configuration Lock and Automatic Operation . . . . .	131
9-4	Changing the Configuration Data . . . . .	133
9-5	Operation for Power Supply Interruptions . . . . .	134
9-5-1	Operation for Voltage Drop . . . . .	134

## 9-1 G9SP-series Controller Operating Modes

### Overview of Operating Modes

The G9SP-series Controller supports the operating modes listed in the following table. The operating mode can be confirmed by checking the MS and MC indicators on the front of the G9SP-series Controller or by using the Device Monitor of the G9SP Configurator. (Refer to *10-1 Monitoring Devices*).

Operating mode	Description	MS indicator	MC indicator
RUN Mode	All functions are supported, including the program.	Lit green	OFF
IDLE Mode	Initialization has been completed, and the G9SP-series Controller is waiting to move to RUN Mode.	Flashing green	OFF
CONFIGURING Mode	Waiting for the configuration to be downloaded.	Flashing green/red	OFF
ABORT Mode	A minor error occurred. The G9SP-series Controller goes into this mode in the following cases. The power supply must be cycled or a reset performed from the G9SP Configurator to return to RUN Mode. 1. An unsupported Expansion I/O Unit is connected. 2. More than two Expansion I/O Units are connected. 3. An unsupported Option Board is connected.	Flashing red	OFF
Memory Cassette Mode	Data is being backed up to a Memory Cassette or restored from a Memory Cassette.	OFF	Flashing or lit yellow
Critical Error (system failure)	A critical error has occurred. The G9SP-series Controller stops all operations and goes into the safe state.	Lit red	OFF
Initialization	Self-diagnosis is being performed to ensure safety functions.	Flashing green/red	OFF



#### Additional Information

The G9SP-series Controller will start in Memory Cassette Mode at any of the following times:

- When an out-of-box G9SP-series Controller is started with a Memory Cassette inserted
- When a Memory Cassette in the G9SP-series Controller contains configuration data that is different from the data in the G9SP-series Controller
- When the G9SP-series Controller is started with pin 4 on the DIP switch turned ON

## Functions Supported in Each Operating Mode

The following table shows the status of each Controller operating mode, and the operations that are supported from the G9SP Configurator in each mode.

Operating mode	Safety functions		Standard functions		Operations from G9SP Configurator														
	Program execution	Logical I/O control	USB communications	Option Board communications	Configuration download	Configuration lock/unlock	Reset	Device password changes	Online monitoring	Force-setting/resetting									
RUN Mode	Executed	I/O refreshed	Supported	Supported	Supported (See note 3.)	Supported	Supported	Supported	Supported	Supported									
IDLE Mode	Stopped										Safe state	Not supported	Not supported	Not supported	Not supported	Not supported	Not supported		
CONFIGURING Mode		Not supported																Supported/Not supported	Not supported
ABORT Mode					Not supported	Not supported													
Memory Cassette Mode		Stopped									Stopped	Not supported	Not supported	Not supported	Not supported	Not supported			
Critical Error (system failure)	Not supported		Not supported	Not supported	Not supported	Not supported													
Initialization							Not supported	Not supported	Not supported	Not supported							Not supported		

### Note

- (1) The safe state means the following:
  - Safety Output terminals are OFF.
- (2) Force-setting and force-resetting can be performed only if the configuration is unlocked.
- (3) The configuration can be downloaded only when a Memory Cassette is not inserted.

## 9-2 Changing the Operating Mode

### Moving between Operating Modes

The following diagram shows mode changes after initialization has been completed at startup.

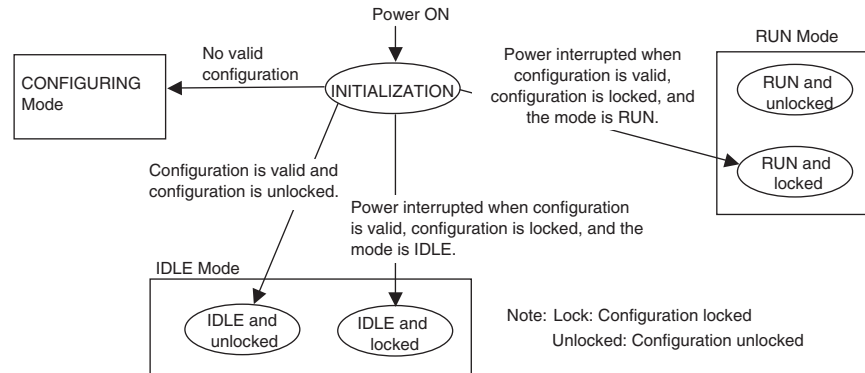

The following diagram shows mode changes for RUN Mode, IDLE Mode, and CONFIGURING Mode.

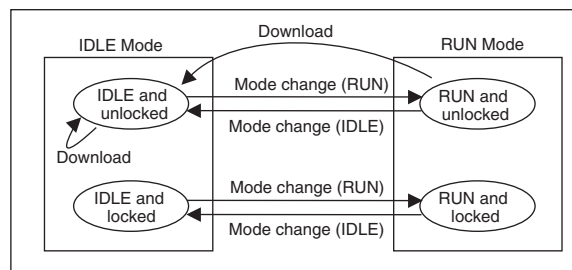

### Procedure for Changing Modes

After the configuration data for the G9SP-series Controller has been downloaded, start program execution by changing the mode using the G9SP Configurator.

1,2,3...

1. Go online and then click the Mode Change (RUN)  Icon.

To return to IDLE Mode, click the Mode Change (IDLE)  Icon,



2. Enter the Device Password when prompted.
3. When the mode has been changed, a message saying that the mode has been changed successfully will be displayed. Confirm that the MS indicator on the G9SP-series Controller is lit green.



## 9-3 Configuration Lock and Automatic Operation

### Configuration Lock

The configuration data that was saved in the G9SP-series Controller can be locked to protect the data after it has been downloaded, verified, and safety validation testing (user testing) has been performed. Once the configuration is locked, the configuration cannot be changed until it is unlocked.

The following occurs when the configuration lock is set.

- The LOCK indicator on the front face of the G9SP-series Controller will light yellow when the data is locked. (When unlocked, the indicator will flash yellow.)
- On the G9SP Configurator, the *Verified [Locked]* is displayed.



\* After the data has been locked, the lock icon will turn yellow if the configuration is changed.

### Configuration Lock Procedure

- 1,2,3... 1. Go online and then click the Configuration Lock  Icon.



2. Input the Device Password when prompted. If a device password is not set, do not input anything.
3. The LOCK indicator on the front of the G9SP-series Controller will light yellow if the configuration is locked successfully. A mark that indicates the locked status will be displayed on the G9SP Configurator.



#### Precautions for Correct Use

The configuration data must be verified before it can be locked. Confirm that “Verified” is displayed on the G9SP Configurator.

### Starting Operating Mode Using Automatic Operation

To protect the user, the G9SP-series Controller will always start in IDLE Mode if safety validation testing (user testing) has not been completed.

After safety validation testing has been completed, the G9SP-series Controller will start in RUN Mode if the following conditions are met. In that case, it will not be necessary to change the mode from the G9SP Configurator.

- The configuration is locked.
- The power was turned OFF after changing to RUN Mode.



#### Precautions for Correct Use

Even if the configuration is locked, the G9SP-series Controller will not start in RUN Mode the next time if the power is turned OFF while in IDLE Mode. Be sure to turn OFF the power while in RUN Mode.

### Unlocking the Configuration

- 1,2,3... 1. Go online and then click the Configuration Unlock  Icon.



2. Input the Device Password when prompted. If a device password is not set, do not input anything.
3. The LOCK indicator on the front of the G9SP-series Controller will light yellow if the configuration is locked successfully. A mark that indicates the unlocked status will be displayed on the G9SP Configurator.

## 9-4 Changing the Configuration Data

This section describes how to change the G9SP-series Controller configuration data after the configuration has been downloaded or after operation has been started.

### **Procedure for Changing the Configuration**

To change the G9SP-series Controller configuration data, first carefully check system safety and then unlock the configuration data. The procedure for changing the configuration is as follows:

- 1,2,3...**
1. Check the system safety.
  2. Change the G9SP-series Controller's operating mode from RUN to IDLE.
  3. Unlock the G9SP-series Controller configuration data.
  4. Download the configuration data to the G9SP-series Controller.
  5. Verify the configuration data.
  6. Change the G9SP-series Controller's operating mode from IDLE to RUN.
  7. Perform safety validation testing (user testing).
  8. Lock the configuration data.



### **Precautions for Safe Use**

---

After changing the G9SP-series Controller's configuration data, confirm that the safety functions are functioning properly before starting operation.

---

## 9-5 Operation for Power Supply Interruptions

### 9-5-1 Operation for Voltage Drop

The G9SP-series Controller monitors the power supply voltage to ensure safe operation. If a voltage over the upper limit or under the lower limit is detected, the following operations will be performed.

#### **Operation for Voltage Errors in Internal Circuit Power Supply**

If a voltage error occurs in the internal circuit power supply, the G9SP-series Controller will stop operation and turn OFF the outputs. The G9SP-series Controller will restart operation when the power supply voltage returns to normal.

#### **Operation for Voltage Errors in Output Circuit Power Supply**

If an error occurs in the output power supply, the G9SP-series Controller will continue operation, but it will stop refreshing outputs. The OUT PWR indicator on the G9SP-series Controller or the I/O power supply monitor can be used to see if the output power supply voltage is being supplied correctly.

#### **Checking Method 1: Using the G9SP Configurator for Monitoring**

Refer to *10-1-3 Error Log* and *10-1-4 Operation Log*.

#### **Checking Method 2: Using the Safety Output Power Supply Error Flag via Option Board Communications**

Refer to *SECTION 7 Communications with a Standard PLC Using an Option Board*.

#### **Checking Method 3: Using the Safety Output Power Supply Error Flag (I/O Tag) in the Program**

Refer to the *G9SP-M□□□ Safety Controller Instructions Reference Manual* (Cat. No. Z923).

**SECTION 10**  
**Checking Operating Status and Debugging**

This section describes how to use a computer to monitor the G9SP-series Controller and how to debug the program by using Force Mode.

10-1	Monitoring Devices . . . . .	136
10-1-1	Device Monitor . . . . .	136
10-1-2	Monitoring Status . . . . .	137
10-1-3	Error Log . . . . .	138
10-1-4	Operation Log . . . . .	139
10-2	Monitoring Programs . . . . .	140
10-2-1	Program Monitor . . . . .	140
10-2-2	Watch Window . . . . .	141
10-3	Debugging in Force Mode . . . . .	143
10-3-1	Force Mode . . . . .	143
10-4	Safety Validation and Preparations for Operation . . . . .	146
10-4-1	Performing Safety Validation Testing (User Testing) . . . . .	146
10-4-2	Backing Up Data to the Memory Cassette . . . . .	146
10-4-3	Outputting and Saving Reports . . . . .	146

# 10-1 Monitoring Devices

The G9SP Configurator can be used for online monitoring of the G9SP-series Controller's operating status, error log, and operation log.

## 10-1-1 Device Monitor

The G9SP Configurator can be used to monitor the G9SP-series Controller simply by connecting the computer online to the G9SP-series Controller.

If an error occurs in the G9SP-series Controller when the G9SP Configurator is online, a red icon (●) will be displayed on the Device Monitor Window to indicate the error. You can double-click the circle to troubleshoot the error.

### Procedure

Go online and then double-click Device Monitor in the Project Window.

### Window Description

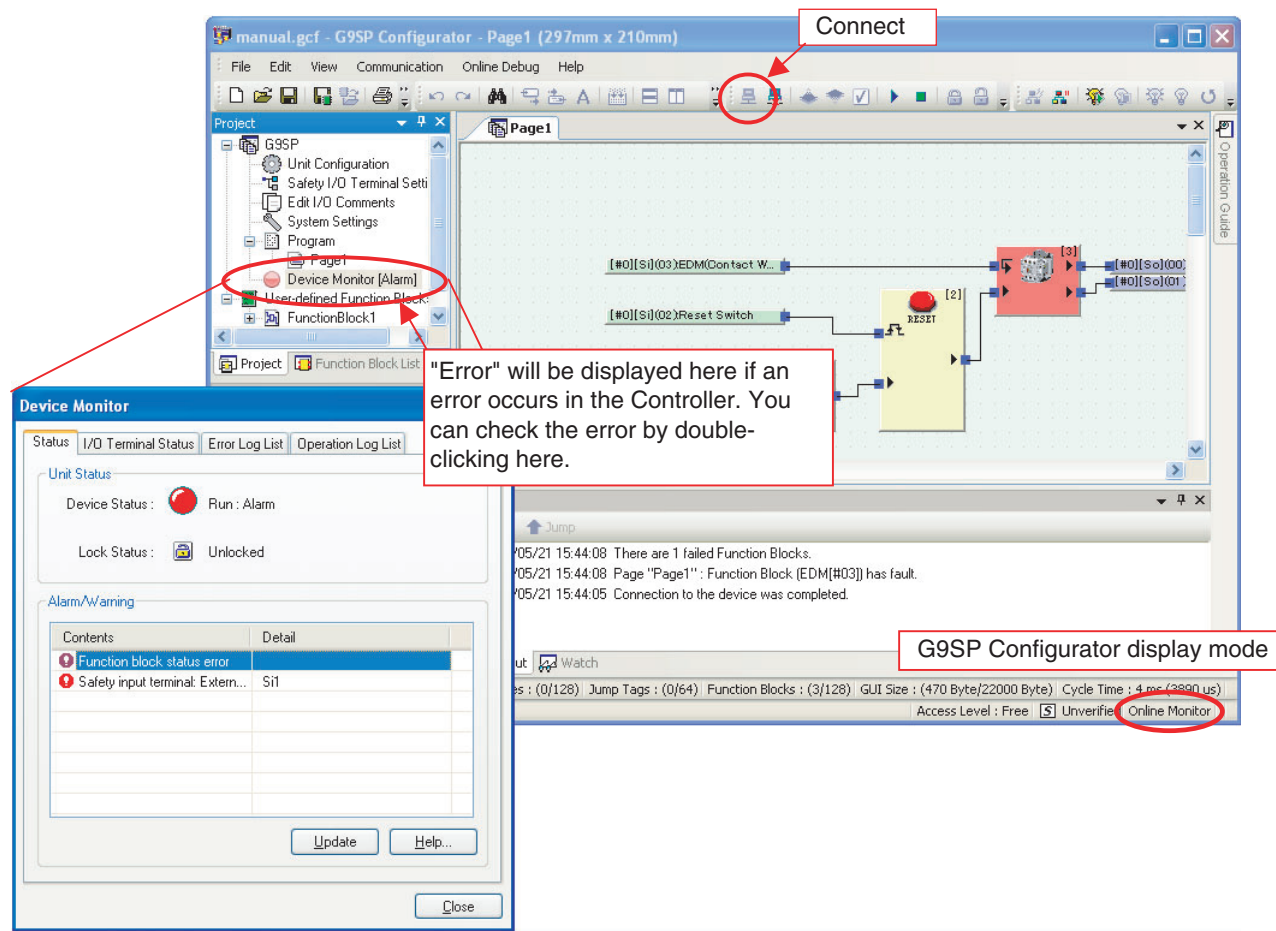

Device Monitor

The following status is displayed in the Device Monitor Window.

Display element	Description
● (gray)	Offline The G9SP Configurator is not online with the G9SP-series Controller.
● (white)	Configuring: Normal Memory Cassette: Normal The G9SP-series Controller is waiting to be configured or data is being backed up or restored with a Memory Cassette.
● (green)	IDLE: Normal The G9SP-series Controller is in IDLE Mode.
● (blue)	RUN: Normal The G9SP-series Controller is in RUN Mode.
● (red)	Alarm An error has occurred in the G9SP-series Controller.

10-1-2 Monitoring Status

G9SP-series Controller’s operating modes and current errors can be checked.

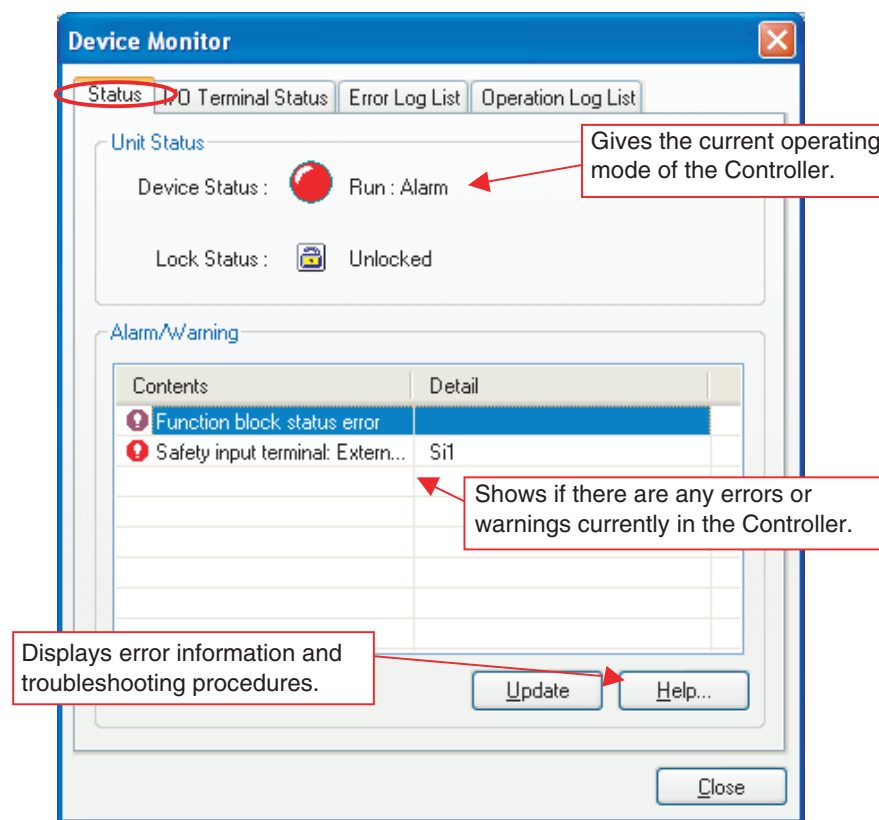

### 10-1-3 Error Log

Past and present G9SP-series Controller errors can be checked. Up to ten errors are stored in the nonvolatile memory in the G9SP-series Controller. They are still retained even when the power is turned OFF and back ON. When more than 10 records are stored, the oldest records are deleted.

The screenshot shows the 'Device Monitor' window with the 'Error Log List' tab selected. The window title is 'Device Monitor'. At the top, there are tabs for 'Status', 'I/O Terminal Status', 'Error Log List', and 'Operation Log List'. Below the tabs, it displays 'Unit Conduction Time : 0 days 5 hours 42 minutes'. A table lists error records with columns 'Time' and 'Content'. The table contains six entries, each starting with a red error icon and a timestamp. To the right of the table, there are two vertical arrows: an upward arrow labeled 'Newer' and a downward arrow labeled 'Older'. Below the table, there are four buttons: 'Update', 'Clear', 'Save...', and 'Help...'. A 'Close' button is at the bottom right. Several red callout boxes with arrows point to specific elements: one points to the 'Time' column with the text 'Displays the unit ON time when the error occurred.'; another points to the 'Content' column with 'Displays the contents of the error.'; a third points to the 'Clear' button with 'Clears all errors from the error log.'; a fourth points to the 'Save...' button with 'Used to save the error log in a CSV-format file.'; and a fifth points to the 'Update' button with 'The error log is not updated when the Error Log List Tab Page is displayed. Always click the **Update** Button.'



#### Precautions for Correct Use

Details on the error can be displayed by clicking the **Help** Button. This information is also provided in *SECTION 13 Troubleshooting* of this manual. Refer to one of these and remove the cause of the error.



#### Additional Information

- The Unit Conduction Time is the total time that the G9SP-series Controller has been operating normally with the power ON. The time is saved every six minutes.
- The error log list is not updated by moving between tabs (i.e., opening another tab page and then again opening the Error Log List Tab Page). To update the display, you must click **Update** Button.



### 10-1-4 Operation Log

Operations that have been performed in the G9SP-series Controller can be checked in the operation log. Up to 10 operations are stored in the nonvolatile memory in the G9SP-series Controller. They are still retained even when the power is turned OFF and back ON. When more than 10 records are stored, the oldest records are deleted.

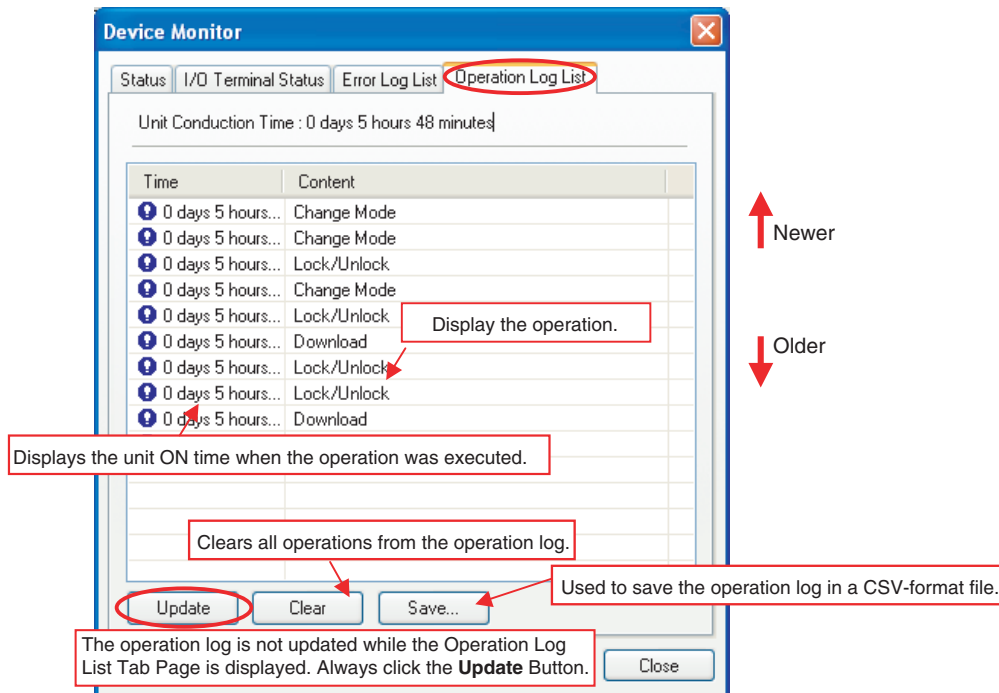

#### Stored Operations

The following operations are stored in the operation log list.

Stored operation	Description
Power ON or emulating cycling power	The G9SP-series Controller was turned ON or reset from the G9SP Configurator.
Out of box reset	The G9SP-series Controller was reset to the default settings.
Download	The configuration data was downloaded from the G9SP Configurator.
Lock/Unlock	The configuration was locked or unlocked from the G9SP Configurator.
Change Mode	The operating mode was changed from the G9SP Configurator.
Start/stop of force mode	Force Mode was started or ended from the G9SP Configurator.
Change device password	The Device Password was changed from the G9SP Configurator.
Clear error log	The error log was cleared from the G9SP Configurator.
Backup to Memory Cassette	The configuration data was backed up from the G9SP-series Controller to the Memory Cassette.
Restore from Memory Cassette	Configuration data was restored from the Memory Cassette to the G9SP-series Controller.



#### Precautions for Correct Use

Only operations that are completed successfully are saved in the operation log list.

## 10-2 Monitoring Programs

### 10-2-1 Program Monitor

The G9SP Configurator can be used to graphically monitor program execution in the G9SP-series Controller.

#### Procedure

- 1,2,3... 1. Go online and then click the Program Monitor Icon .
2. The background of the Program Window will change to light blue and "On-line Monitor" will be displayed at the lower right of the window.

#### Window Description

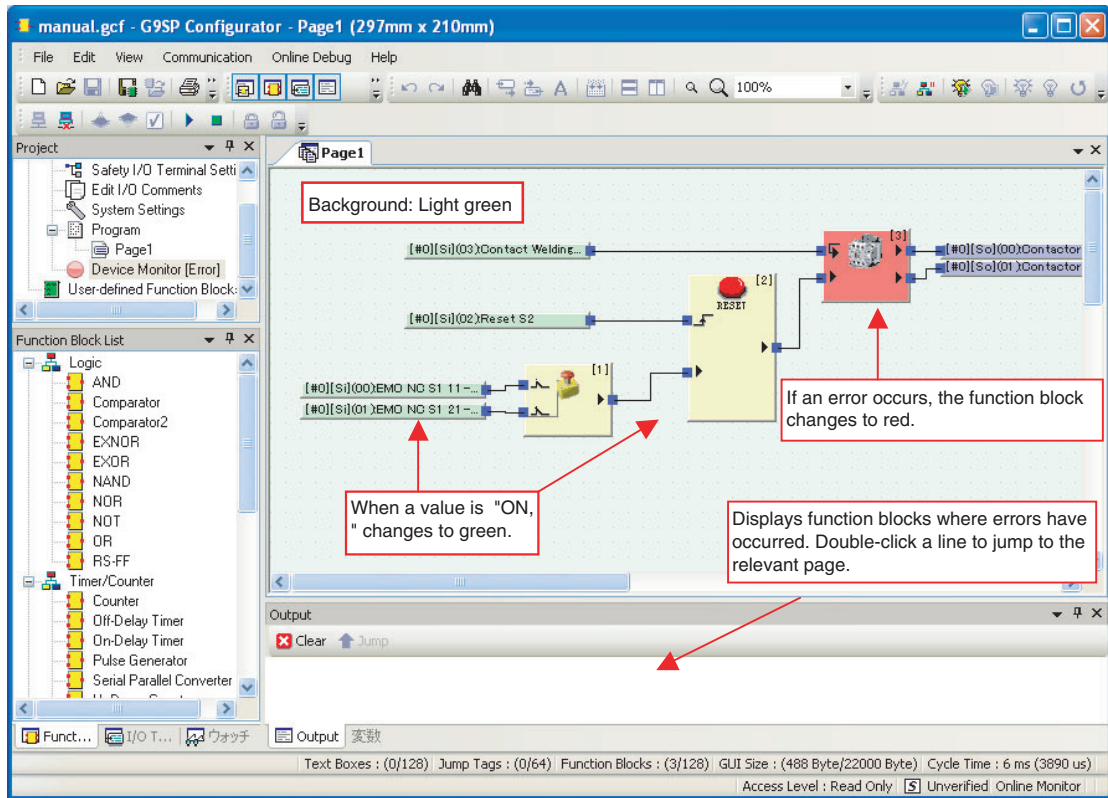

#### Additional Information

- The display of function blocks with errors in the Output Window can be updated by selecting **Search Failed Function Blocks** from the Online Debug Menu.
- The program and configuration data, such as the system settings, cannot be changed while monitoring the program. End program monitoring to change them.

### 10-2-2 Watch Window

The Watch Window of the G9SP-series Controller can be used to increase the efficiency of debugging.

#### Monitoring I/O Tag Values

You can register any I/O tags to the Watch Window to monitor the ON/OFF status in the Watch Window. This is convenient for monitoring changes in the values of I/O tags that are located on different pages, as shown below.

#### Example: Simultaneously Monitoring I/O Tags on Different Pages

To check the value of an output tag on page 2 when an input tag on page 1 changes, the output tag can be registered to the Watch Window so that the status of both tags can be monitored while displaying page 1.

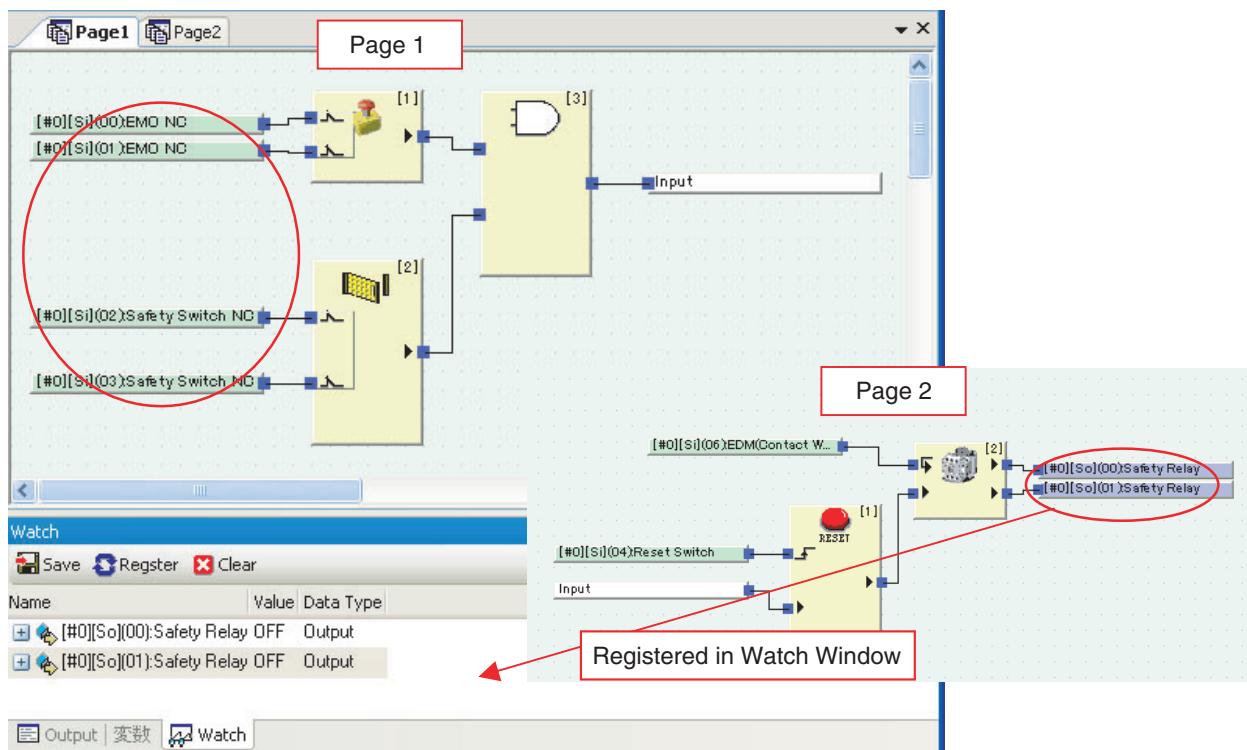

#### Analysis Displays for Related I/O Tags

With the G9SP Configurator, the I/O tags that are related to I/O tags that are registered to the Watch Window can be analyzed. As shown in the following example, input tags related to an output tag are displayed, and then the output can be checked to make sure it turns OFF when one of the input tags turns OFF.

**Example: Confirming an Output to See If It Turns OFF Correctly**

The output tag to be checked is registered to the Watch Window and then a tree hierarchy is opened for the output tag. The related input tags are displayed in a list and can be turned ON and OFF to monitor the corresponding changes in the output tag. This enables effective monitoring to help prevent omitting items that need to be checked.

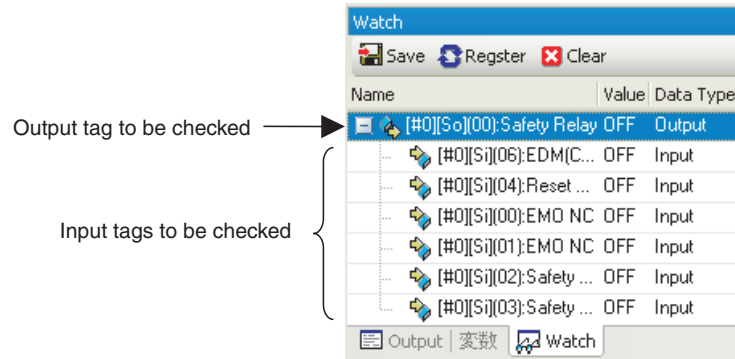
**Registering and Deleting I/O Tags in the Watch Window****Registering Individual I/O Tags**

Right-click the I/O tag in the Program Window or I/O Tag List Window and select **Register to Watch Window**.

**Registering All I/O Tags in Use**

Click the **Register** Button in the Watch Window.

**Deleting Individual I/O Tags**

Right-click an I/O tag in the Watch Window and select **Clear**.

**Deleting All I/O Tags from the Watch List**

Click the **Clear** Button in the Watch Window.

**Additional Information**

You can save all of the I/O tags in the Watch Window and the list of related I/O tags in a CSV-format file. This can be used to provide shutoff conditions for the Safety Output devices that are being used.

## 10-3 Debugging in Force Mode

I/O tags can be force-set and force-reset in the Program Monitor Window. When an I/O tag is force-set or force-reset, the I/O status used in the program is turned ON or OFF regardless of the actual ON/OFF status of the I/O terminals or communications data. This can be used to check the wiring of outputs and check operation of the G9SP-series Controller even when communications are not yet connected to enable efficient debugging.



### Precautions for Correct Use

- Force-setting and force-resetting can be performed only when the configuration data of the G9SP-series Controller is unlocked.
- Program execution is stopped and the G9SP-series Controller enters the IDLE Mode when Force Mode is ended or Force Mode times out.

**WARNING** Outputs may operate, possibly resulting in serious injury. Take sufficient safety measures before force-setting or force-resetting tags in the program.

### 10-3-1 Force Mode

It is necessary to change the G9SP-series Controller to Force Mode to force-set or force-reset I/O.

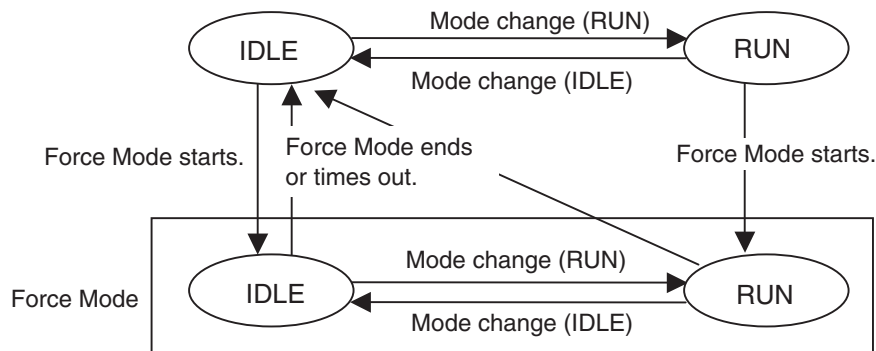

#### Starting Force Mode

You must input the Device Password to change to Force Mode. Force Mode can be entered only when the configuration data in the G9SP-series Controller is unlocked.

#### Monitoring Force Mode Time

A limit can be set for the time that the G9SP-series Controller will continue in Force Mode. The duration time is specified when Force Mode is started or restarted. The upper limit of the duration time is 24 hours. The G9SP-series Controller will end Force Mode if the specified duration time elapses.

### Ending Force Mode

There are three ways to end Force Mode.

#### Ending Force Mode with the G9SP Configurator

- Program execution is stopped and the G9SP-series Controller enters the normal IDLE Mode when Force Mode is ended or Force Mode times out.
- The I/O that were force-set or force-reset are returned to the actual values when Force Mode ends.

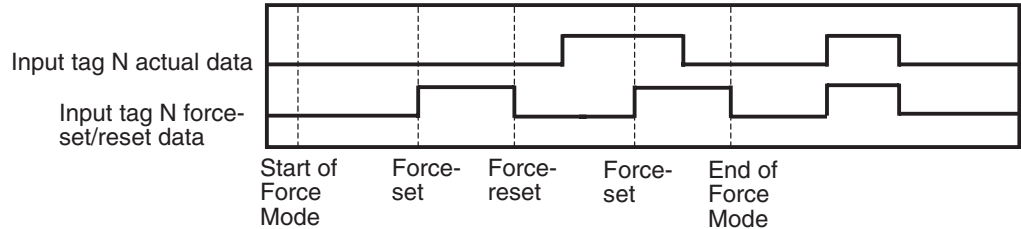

#### Elapse of Force Mode Duration Time

- Program execution is stopped and the G9SP-series Controller enters the IDLE Mode when the Force Mode Duration Time expires.
- The I/O that were force-set or force-reset are returned to the actual values when Force Mode ends.

#### Changing Controller to a Mode Other Than IDLE or RUN

The mode will be changed by downloading, resetting, turning OFF the power supply. The Force Mode will continue, however, if a change is made between IDLE Mode and RUN Mode.

### Force Mode at Startup

If the power supply is turned OFF while the G9SP-series Controller is in Force Mode, the G9SP-series Controller will start the next time in a normal mode. Start the Force Mode again if required.

### Procedure and Windows

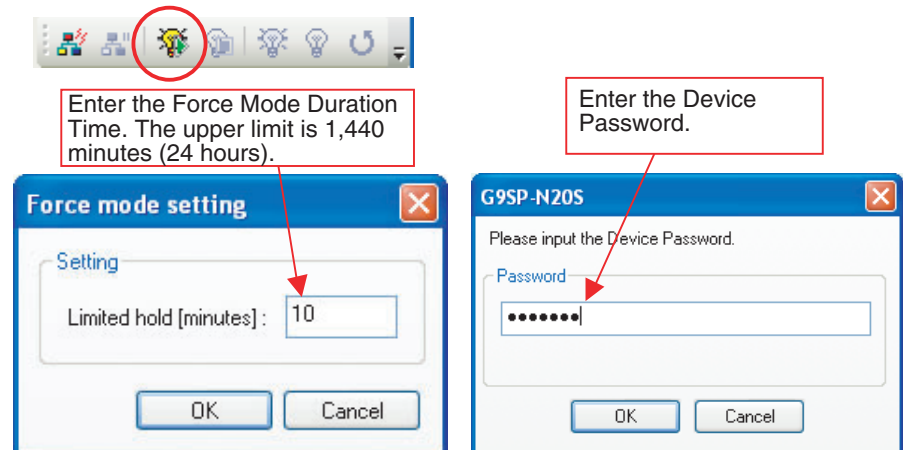

- 1,2,3... 1. Starting Force Mode

Press the  (Start/Restart Force Mode) Button in the Program Monitoring Window. Enter the Device Password and duration time in the following dialog box. The background in the Program Window will change to orange and “Force Mode” will be displayed at the lower right of the window.



2. Force-setting/resetting I/O Tags

Right-click the desired I/O tag and then select one of the following buttons.

Button	Operation	Description
	Force-set	The output will be turned ON regardless of the actual ON/OFF status.
	Force-reset	The output will be turned OFF regardless of the actual ON/OFF status.
	Reverse status	Reverses the current ON/OFF status.
---	Cancel forced status	The force-set or force-reset status will be cleared and the output will return to the actual ON/OFF status.

**Closing the Program Monitor While Continuing in Force Mode**

You can close the Program Monitor while continuing in Force Mode.

**Procedure**

Close the Program Monitor. The force-set and force-reset status of the I/O tags that has been set until that point will be held.

**Procedure for Restarting**

Once the Program Monitor Window has been closed, the right to perform force-set or force-reset I/O tags will be lost. To force-set or force-reset I/O tags again, click the  (Start/Restart Force Mode) Button, and then enter the Device Password and duration time. You will be able to obtain the right to force-set or force-reset I/O tags with the force-set or force-reset status that was saved.

**Extending the Duration Time for Force Mode**

Click the  (Start/Restart Force Mode) Button to extend the duration time for Force Mode.

## 10-4 Safety Validation and Preparations for Operation

The following operations are performed after checking G9SP-series Controller operation and completing debugging and before starting actual operation.

1. Performing safety validation testing (user testing)
2. Backing up data to the Memory Cassette
3. Printing and saving a report

### 10-4-1 Performing Safety Validation Testing (User Testing)

Safety validation testing is performed to confirm that all of the Safety Functions of the entire system containing the G9SP-series Controller are operating correctly. After completing safety validation testing, the configuration is locked to protect it from unintentional changes.



---

#### Additional Information

Locking the configuration enables automatic operation of the G9SP-series Controller in RUN Mode. Refer to *9-3 Configuration Lock and Automatic Operation* for details.

---

 **WARNING** Serious injury may possibly occur due to loss of required safety functions. Perform user testing and confirm that all of the G9SP-series Controller's configuration data and operation is correct before starting system operation.

### 10-4-2 Backing Up Data to the Memory Cassette

After the configuration data is locked, it is backed up to a Memory Cassette. Refer to *SECTION 11 Backup and Restore Data Using Memory Cassette* for Memory Cassette functions, details, and procedures.



---

#### Additional Information

- Memory Cassettes can be used to greatly reduce the work required in replacing a G9SP-series Controller. We recommend that you use Memory Cassettes.
  - Configuration data must be locked before it can be backed up to a Memory Cassette.
- 

### 10-4-3 Outputting and Saving Reports

After the configuration data has been completed, it can be checked in a report, which can be printed or saved as required. Refer to *6-2-5 Displaying and Printing Reports* for the procedures.



**SECTION 11**  
**Backup and Restore Data Using Memory Cassette**

This section describes how to use Memory Cassettes.

11-1 Overview . . . . .	148
11-1-1 Memory Cassette Operations . . . . .	148
11-1-2 Application Example . . . . .	148
11-2 Backing Up Data to the Memory Cassette . . . . .	150
11-3 Restoring Data to G9SP-series Controller . . . . .	152
11-4 Checking Configuration Data Using Indicators . . . . .	155

## 11-1 Overview

The maintenance efficiency of the G9SP-series Controller can be improved by using an optional CP1W-ME05M Memory Cassette.

### 11-1-1 Memory Cassette Operations

With the G9SP-series Controller, configuration data can be backed up from the G9SP-series Controller to the Memory Cassette and settings can be restored to the G9SP-series Controller from the Memory Cassette without using a computer.

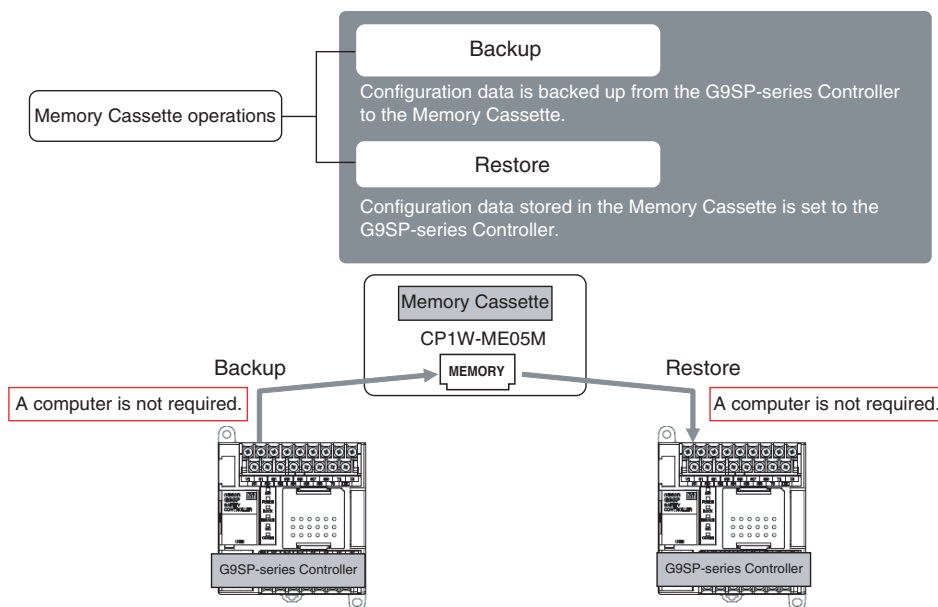

### 11-1-2 Application Example

The operations of the G9SP-series Controller's Memory Cassette can be used for the following applications.

#### Replacement of the G9SP-series Controller Due to Failure

If replacing the G9SP-series Controller is required due to failure during operation, the configuration data can be set (i.e., restored) to the replacement G9SP-series Controller without using a computer. Once restoring the data has been completed, the replacement G9SP-series Controller will automatically start to operate in the same way as the previous Controller.

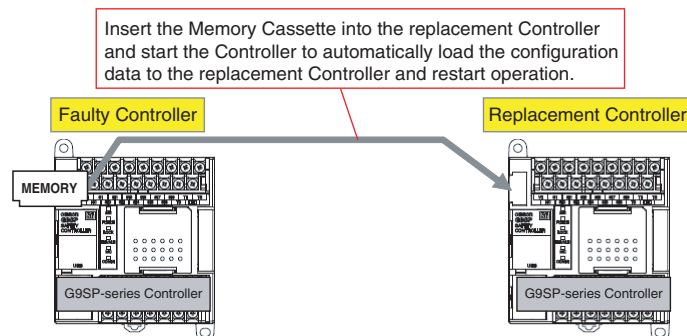

\* The configuration data must be backed up in the Memory Cassette in advance.

### Updating G9SP-series Controller's Configuration Data at Version Upgrade of Existing Equipment

If updating the G9SP-series Controller's configuration data is required due to a version upgrade of existing equipment, the new configuration data can be set (i.e., restored) without using a computer. Once restoring has been completed and updating has been performed, the G9SP-series Controller will automatically start to operate in the same way as before updating.

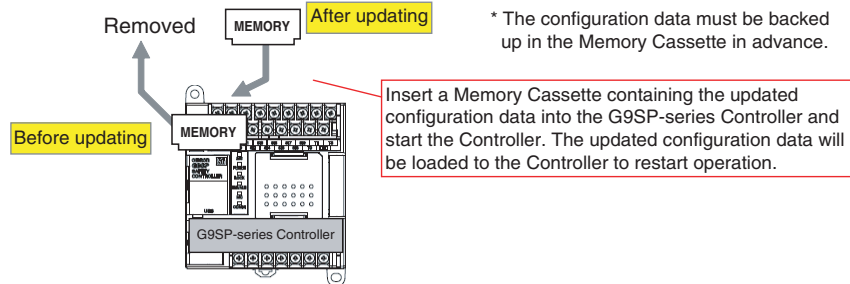

### Copying G9SP-series Controller Data for Mass Production of Equipment with Identical Contents

Identical settings can be easily made to multiple G9SP-series Controllers using one Memory Cassette when mass production of identical equipment is performed. Once restoring has been completed, the G9SP-series Controller will automatically start to operate when the power supply is turned ON.

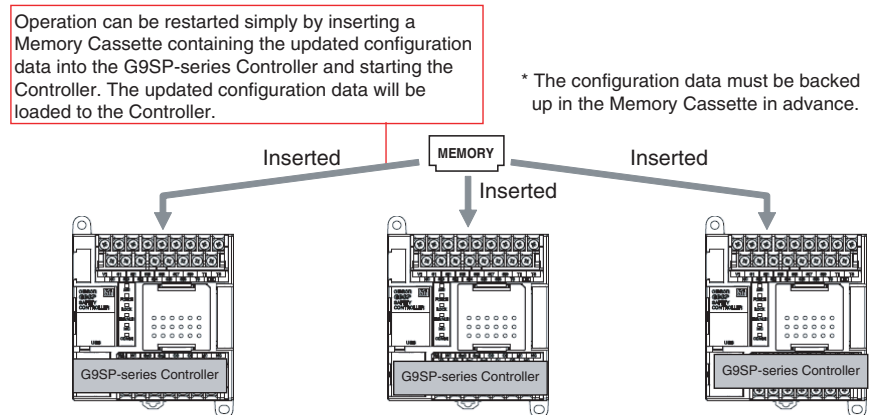

#### Precautions for Safe Use

Once restoring data has been completed using the Memory Cassette, the G9SP-series Controller will automatically start to operate. Be sure to always turn OFF the power supply to power lines and check system safety before restoring data with a Memory Cassette.



#### Precautions for Correct Use

Make sure the power supply of the G9SP-series Controller is OFF when inserting or removing the Memory Cassette. Inserting or removing the Memory Cassette while the power is being supplied may cause failure of the G9SP-series Controller.

## 11-2 Backing Up Data to the Memory Cassette

This section describes the conditions and procedures for backup.

### Conditions

The following conditions must be satisfied to perform backup.

- The configuration data of the G9SP-series Controller must be locked.  
To ensure safety after restoring, it is necessary to use configuration data for which safety validation testing (i.e., user testing) has been completed.

### Procedure

- 1,2,3...
1. Turn OFF the power supply to the G9SP-series Controller, and then insert the Memory Cassette.
  2. Turn ON DIP switch pin 4 on the front of the G9SP-series Controller, and then turn ON the power supply to the G9SP-series Controller.
  3. The G9SP-series Controller will start using the following indicators.

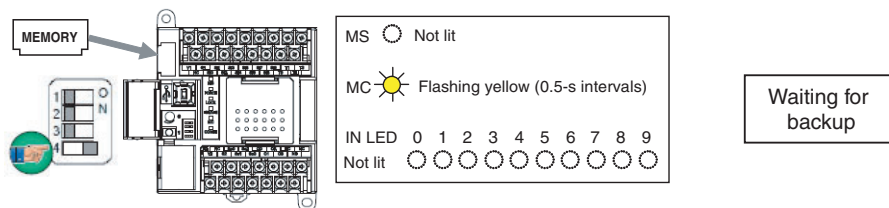

4. In this status, press the Push Switch on the front of the G9SP-series Controller for at least 1 s to start backup. During backup, the Safety Input terminal indicators will sequentially light from right to left in yellow.

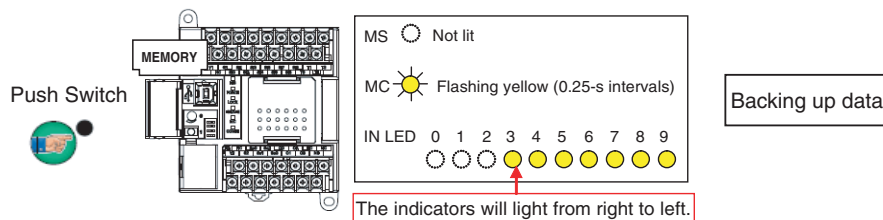

5. The following indicators will light when backup has been completed. At this point, the ID of the backup configuration will be sequentially lit on the Safety I/O terminal indicators. This ID is called the configuration ID and consists of a four-digit decimal number to identify the configuration data. For details, refer to 11-4 Checking Configuration Data Using Indicators.

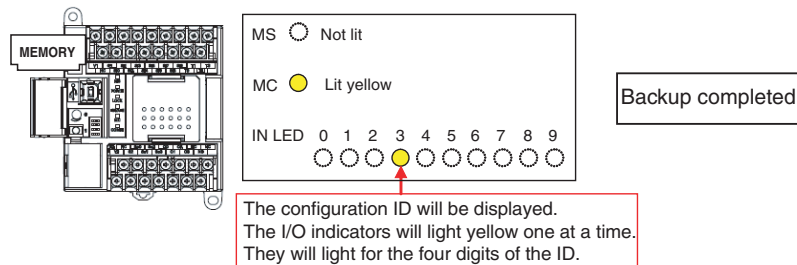

This completes the backup procedure. To return to the normal operating mode, turn OFF DIP switch pin 4, and then cycle the power supply to the G9SP-series Controller.

If an error occurs during the backup operation, the ERR/ALM indicator will light red, and the terminal number will light red on the Safety Input terminal indicators to indicate the error details. Refer to 13-2 Error Details and Measures to remove the error.

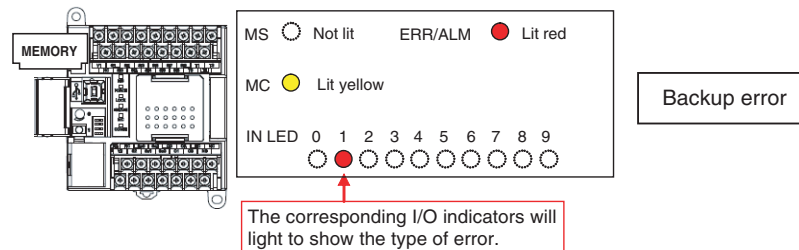

### Precautions for Correct Use

- Backing up data to the Memory Cassette can be performed only when the G9SP-series Controller's configuration data is locked. Conduct a safety confirmation test (i.e., user test) and lock the configuration data before performing the backup.
- Complete backup in advance, before using the G9SP-series Controller if the Memory Cassette is going to be used for efficient replacement of the G9SP-series Controller in the event of failure. Backup may not be performed correctly after failure of the G9SP-series Controller.
- Performing a backup overwrites the data on the Memory Cassette. Be sure to confirm that the Memory Cassette contains no required data before performing backup.

### Note

- (1) Formatting the Memory Cassette is not required.
- (2) The contents of the Memory Cassette can be checked by verifying the configuration ID to prevent setting incorrect configuration data when restoring data to the G9SP-series Controller is performed from the Memory Cassette. To enable performing this verification, record the configuration ID when performing backup.

## 11-3 Restoring Data to G9SP-series Controller

This section describes the conditions and procedures for restoring data.

### Conditions

The following conditions must be satisfied to restore data.

- Backup of Correct Data on a Memory Cassette  
The configuration data must be backed up on a Memory Cassette in advance.
- Device Password Match  
If a device password is set, the device password set for the G9SP-series Controller must match the device password that is backed up on the Memory Cassette. A device password is not set in the default settings.
- Prohibit Restore Setting Disabled  
The restore prohibition setting made for the G9SP-series Controller must be disabled. Restore prohibition is enabled in the default settings.
- Model Information (Model and Unit Version) Match  
The model information in the configuration data stored on the Memory Cassette must match the model information in the G9SP-series Controller.

### What Is Restore Prohibition?

This setting enables prohibiting restoring data using a Memory Cassette to prevent incorrect or improper restoration for equipment at the work site. If the prohibit restore setting is enabled, a computer will be required to update the configuration data. Be sure to set this setting correctly.

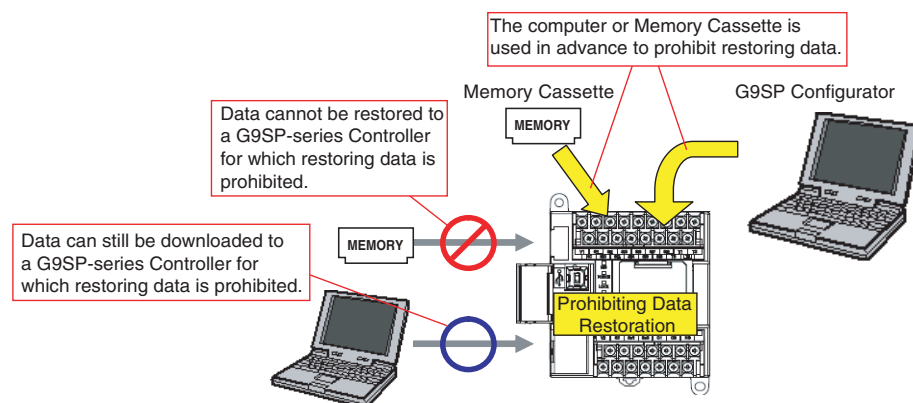

The prohibit restore setting is made in the system settings from the G9SP Configurator. For the setting procedure, refer to *SECTION 6 Creating Configuration Data*.

**Procedure**

- 1,2,3...
1. Turn OFF the power supply to the G9SP-series Controller, and then insert the Memory Cassette.
  2. Turn OFF DIP switch pin 4 on the front of the G9SP-series Controller, and then turn ON the power supply to the G9SP-series Controller.

The system will start in restore standby status at step 3 if the configuration data stored in the Memory Cassette does not match the configuration data stored in the G9SP-series Controller.

3. After startup, the ID of the configuration data on the Memory Cassette will light sequentially on the Safety Input terminal indicators of the G9SP-series Controller.

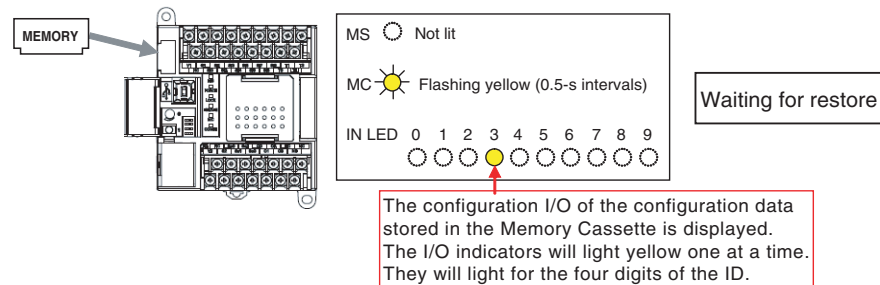

4. Once the display configuration ID has been verified and it is confirmed that the intended configuration data has been stored in the Memory Cassette, press the Push Switch on the front of the G9SP-series Controller for at least 1 s to start restoring data. During the restore operation, the Safety Input terminal indicators will be sequentially lit from left to right in yellow.

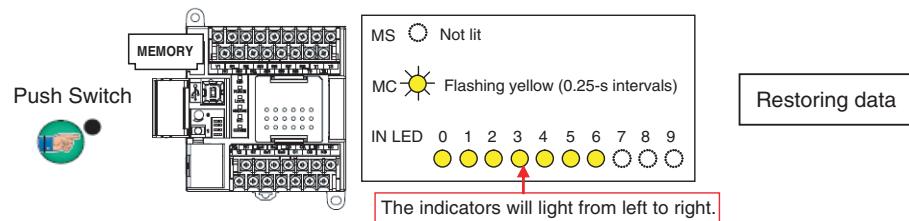

5. Once the restore operation has been completed, the G9SP-series Controller will restart and operate in RUN Mode with the configuration locked.

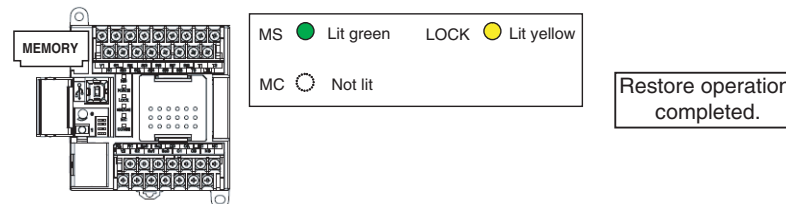

If an error occurs during the restore operation, the ERR/ALM indicator will light red, and a terminal number will light red to indicate the error details on the Safety Input terminal indicators. Refer to 13-2 Error Details and Measures to remove the error.

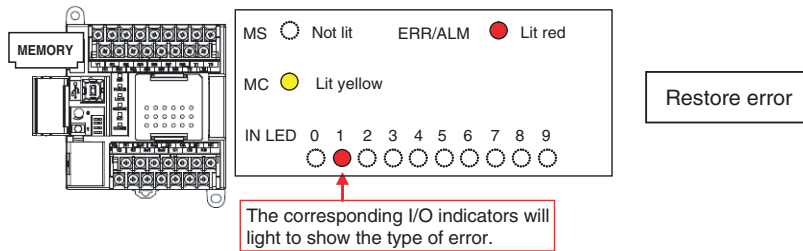

### Precautions for Correct Use

Operation will always start in restore waiting status when startup is performed with the Memory Cassette inserted into the G9SP-series Controller using the default settings. Make sure the Memory Cassette is not inserted when downloading the configuration data from a computer.

Verification of the configuration ID is performed to prevent restoring incorrect configuration data.

**⚠ WARNING** Serious injury may possibly occur due to loss of required safety functions. Once the data has been restored from the Memory Cassette, check that the configuration data of the G9SP-series Controller is correct in that it operates properly and carry out the validation testing (User Testing).



## 11-4 Checking Configuration Data Using Indicators

An ID can be displayed on the I/O indicators of the G9SP-series Controller to identify the configuration data. This is used to check the configuration data in present operation or to check configuration data on the Memory Cassette before restoring data.

### What Is a Configuration ID?

The configuration ID is a 4-digit decimal code that is generated from the configuration data created on the G9SP Configurator. Data is generated from settings not related to safety, such as function block placement information and I/O comments, in addition to safety-related settings, such as Safety I/O terminal settings and programming. Therefore, the configuration ID is a different value even when there have been changes in safety-related settings or changes that do not affect operation of the G9SP-series Controller, such as changes in function block assignment.

### What Is a Safety Signature?

This is a code that is generated from the safety-related settings made with the G9SP Configurator. It is used to check if there has been a change that will affect the operation of the G9SP-series Controller.

Code	Contents
Signature code	This is a four-digit hexadecimal code generated from safety-related settings.
Signature date	This is the time when the safety-related settings were made using the G9SP Configurator.

### Checking with the G9SP Configurator

- 1,2,3... 1. Right-click the unit name in the Project Window and select **Property**.
2. Click the **Signature** Tab.

### Checking the Configuration ID

The section describes how to check the configuration ID.

#### Checking the Configuration Data in Present Operation

- 1,2,3... 1. Press the Push Switch for at least 1 s on the front of the G9SP-series Controller when it is operating in IDLE Mode or RUN Mode.
2. After 1 s, the configuration ID will be displayed on the Safety Input terminal indicators of the G9SP-series Controller.

#### Checking the Configuration Data Stored on the Memory Cassette

Refer to step 3 in 11-3 Restoring Data to G9SP-series Controller.



**SECTION 12**  
**Maintenance and Inspections**

This section describes the inspections for G9SP-series Controller and precautions when replacing the G9SP-series Controller.

12-1 Inspections .....	158
12-2 G9SP-series Controller Replacement Precautions .....	159

## 12-1 Inspections

Daily or periodic inspections are required in order to maintain the G9SP-series Controller functions in good operating condition. In this section, the G9SP-series Controller is referred to as simply the “Controller.”

- Confirm that the Controller is being used within the specifications.
- Confirm that the Controller is mounted and wired correctly.
- Check the safety functions in order to maintain their operating reliability at a constant level.
- Use the error log to check for non-fatal errors.

### ■ Periodic Inspection Points

No.	Item	Inspection	Criteria	Action
1	Source power supply	Check for voltage fluctuations at the power supply terminals.	The voltage must be within the allowable voltage fluctuation range. (Refer to <i>SECTION 2 Part Names and Specifications.</i> )	Use a voltage tester to check the power supply at the terminals. Take necessary steps to bring voltage fluctuations within limits.
2	Ambient environment	Check the ambient temperature. (Inside the control panel if the Controller is in a control panel.)	0 to 55°C (Refer to <i>SECTION 2 Part Names and Specifications.</i> )	Use a thermometer to check the temperature and ensure that the ambient temperature remains within the allowed range of 0 to 55°C.
		Check the ambient humidity. (Inside the control panel if the Controller is in a control panel.)	10% to 95% (with no condensation.) (Refer to <i>SECTION 2 Part Names and Specifications.</i> )	Use a hygrometer to check the humidity and ensure that the ambient humidity remains between 10% and 95%. Make sure that condensation does not occur due to rapid changes in temperature.
		Check that the Controller is not in direct sunlight.	Not in direct sunlight	Protect the Controller if necessary.
		Check for accumulation of dirt, dust, salt, metal filings, etc.	No accumulation	Clean and protect the Controller if necessary.
		Check for water, oil, or chemical sprays hitting the Controller.	No spray on the Controller	Clean and protect the Controller if necessary.
		Check for corrosive or flammable gases in the area of the Controller.	No corrosive or flammable gases	Check by smell or use a gas sensor.
		Check the level of vibration or shock applied to the Controller.	Vibration and shock must be within specifications. (Refer to <i>SECTION 2 Part Names and Specifications.</i> )	Install cushioning or shock absorbing material if necessary.
		Check for noise sources near the Controller.	No significant noise sources (Refer to <i>SECTION 2 Part Names and Specifications.</i> )	Either separate the Controller and noise source or protect the Controller.
3	Installation and wiring	Check that all terminal blocks between Units are inserted and locked fully.	No looseness (Refer to <i>SECTION 4 Installation and Wiring.</i> )	Press the terminal block on completely and lock them with the screws.
		Check that cable connectors are fully inserted and locked.	No looseness (Refer to <i>SECTION 4 Installation and Wiring.</i> )	Press the connectors on completely and lock them.
		Check for loose screws in external wiring.	No looseness	Tighten loose screws with a Phillips screwdriver.
4	Performing safety validation testing (user testing)	Make sure that all safety functions are operating correctly.	The safety functions must be operating as intended.	Remove any errors and then recheck the operation of all safety functions.

## 12-2 G9SP-series Controller Replacement Precautions

When replacing a Controller after discovering a problem during inspection, pay attention to the following points.

- Do not attempt to disassemble, repair, or modify the Units in any way. Doing so may impair the original safety functions.
- Make sure that safety can be assured when replacing the Unit.
- To prevent electric shock or unexpected operation, always turn OFF the power before replacing the Unit.
- After replacing the Unit, check the new Unit to make sure that there are no errors.



### Precautions for Safe Use

After replacing a Controller, reset the program and all configuration data required for restarting the user program and confirm that the safety functions are operating normally before starting this operation.

## Making Settings and Wiring the New Unit

### Replacing and Wiring the Unit

Remove the faulty Unit and mount and wire the new Unit.

Refer to *SECTION 4 Installation and Wiring*.

## Downloading Configuration Data and Checking Operation

### Operation Using the G9SP Configurator

Download the configuration data to the new Controller and check the operation of the safety system.

Refer to *SECTION 8 Connecting Online and Downloading to the G9SP-series Controller*.

Refer to *SECTION 9 Operation and Operating Modes*.

### Operation Using a Memory Cassette

Insert the Memory Cassette in the new Controller, restore the configuration data, and check the operation of the safety system.

Refer to *SECTION 11 Backup and Restore Data Using Memory Cassette*.



This section describes how to troubleshoot problems that may occur with the G9SP-series Controller.

13-1	Overview of Troubleshooting . . . . .	162
13-1-1	Errors and Remedies . . . . .	162
13-1-2	Checking the Indicators . . . . .	162
13-1-3	Identifying Errors . . . . .	164
13-2	Error Details and Measures . . . . .	165
13-2-1	Fatal Errors . . . . .	165
13-2-2	Non-fatal Errors . . . . .	167

# 13-1 Overview of Troubleshooting

This section describes how to troubleshoot errors that occur in the G9SP-series Controller.

## 13-1-1 Errors and Remedies

Use the following procedure when an error occurs.

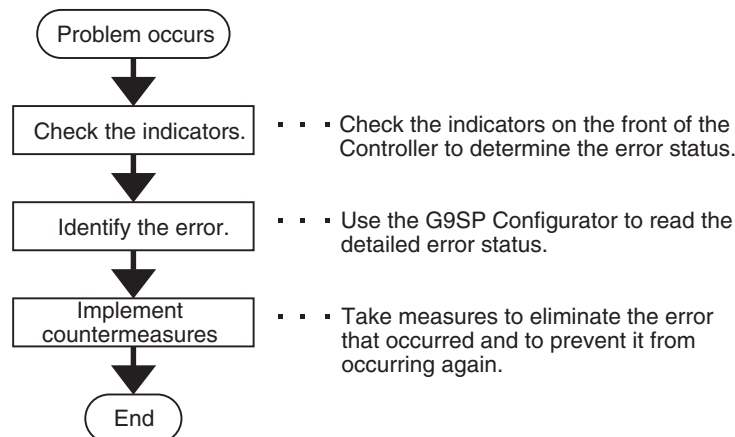

## 13-1-2 Checking the Indicators

The type of error that occurred can be determined by checking the indicators on the front of the G9SP-series Controller.

MS		FORCE	LOCK	ERR/ALM	MC	COMM	OUT PWR	I/O		Status
Green	Red	Yellow	Yellow	Red	Yellow	Yellow	Green	Yellow	Red	
<b>Normal operating status</b>										
⊗	●	---	⊗	●	●	---	---	---	---	Normal operating status after completing user testing
⊗	●	---	⊗	●	●	---	---	---	---	Normal operating status during user testing
⊗	●	---	---	●	●	---	---	---	---	Operating status is normal, but the Safety Output does not turn ON.
<b>Stopped but no error detected</b>										
●	●	---	---	●	●	---	---	---	---	Internal power not supplied
⊗	●	---	---	●	●	---	---	---	---	Stopped in IDLE Mode
⊗	⊗	---	---	●	●	---	---	---	---	Stopped in CONFIGURATION Mode
●	●	---	---	●	⊗	---	---	---	---	Memory Cassette operation in progress (backup/restore)
<b>Fatal error detected</b>										
●	⊗	---	---	---	---	---	---	---	---	Critical status: System error detected
●	⊗	---	---	⊗	---	---	---	---	---	Abort status: Minor error detected
●	●	---	---	⊗	⊗	---	---	---	⊗	Error detected in Memory Cassette operation (backup/restore)
<b>Non-fatal error detected</b>										
---	---	---	---	⊗	---	---	---	---	---	Non-fatal error detected



● : Not lit ◐ : Flashing ○ : Lit ---: Not relevant

**Normal Operating Status**

In this status, the G9SP-series Controller is executing programming and operating normally. Operating status is divided into the following two states. For details, refer to *9-3 Configuration Lock and Automatic Operation*.

Status	Action
Normal operating status after completing user testing	User testing has been completed, and normal operation is being performed in automatic operating mode. No particular measures are required.
Normal operating status during user testing	User testing has not been completed, and so operation is being performed with the configuration unlocked. The present operation is normal, but the system will start in IDLE Mode at the next startup. Change the operating mode from the G9SP Configurator at every startup until user testing has been completed.
Operating status is normal, but the Safety Output does not turn ON.	The following causes are possible. If none of the actions corrects the problem, the Unit may be faulty. In that case, replace the Unit. <ol style="list-style-type: none"> <li>1. Check to see if the output tag is ON. Use the program monitor to see if the output tag is displayed in green, indicating that it is ON.</li> <li>2. Check to see if the Safety Output terminal is set. Open the Safety I/O terminal settings to check the setting.</li> <li>3. Either 24 V is not being applied to other Safety Output terminals or Standard Output terminals or the power supply positive terminal is not connected. If this occurs, the output power supply OFF test will fail, so the Safety Output will not turn ON for safety reasons. Check the wiring and cycle the output power supply.</li> </ol>

**Stopped But No Error Detected**

The G9SP-series Controller is not executing programming and operation is stopped. However, no particular error has been detected in this status, and so observe the following points to perform operation.

Status	Action
Internal power not supplied	Check the following before supplying the rated power. <ul style="list-style-type: none"> <li>• Is the power supply voltage within the specifications?</li> <li>• Is the wiring correct or connected properly?</li> </ul> The Unit may have failed if the measured voltage at terminal V1/G1 is normal. In that case, replace the Unit.
Stopped in IDLE Mode	<ol style="list-style-type: none"> <li>1. Change the operating mode using the G9SP Configurator (<i>9-2 Changing the Operating Mode</i>).</li> <li>2. Refer to <i>9-3 Configuration Lock and Automatic Operation</i> if the system starts in IDLE Mode when it was previously operated in RUN Mode.</li> <li>3. The mode will change from RUN Mode to IDLE Mode when the Force Mode times out. Take suitable measures, such as starting Force Mode again.</li> </ol>

Status	Action
Stopped in CONFIGURATION Mode	Configuration data has not been downloaded to the G9SP-series Controller. Refer to <i>SECTION 8 Connecting Online and Downloading to the G9SP-series Controller</i> , and download the configuration data.
Memory Cassette operation in progress (backup/restore)	The G9SP-series Controller will start by performing a Memory Cassette operation if it is started under any of the following conditions. Refer to <i>SECTION 11 Backup and Restore Data Using Memory Cassette</i> , and take suitable measures. <ul style="list-style-type: none"> <li>• The G9SP-series Controller is in default status (i.e., waiting for configuration) and a Memory Cassette is inserted.</li> <li>• Or, the data stored on the inserted Memory Cassette is different from the configuration data in the G9SP-series Controller.</li> <li>• Or, DIP switch pin 4 is ON.</li> </ul>

**Fatal Error Detected**

The G9SP-series Controller has detected an error that prevents operation, and so the program is not executed and operation is stopped. Take the following measures.

Status	Action
Critical status: System error detected	A fatal error has occurred (e.g., hardware failure or assert error). If this occurs again after the power supply is cycled, hardware failure is probable. Replace the G9SP-series Controller.
Abort status: Minor error detected	A minor error (e.g., unsupported Unit mounted) from which recovery is possible has occurred. Check the following, confirm proper system configuration, and then cycle the power supply. <ol style="list-style-type: none"> <li>1. Is an unsupported Expansion I/O Unit mounted?</li> <li>2. Are three or more Expansion I/O Units mounted?</li> <li>3. Is an unsupported Option Board mounted? (In particular, only unit version 2.0 or later of the CP1W-CIF41 Ethernet Option Board is supported.)</li> </ol>
Error detected in Memory Cassette operation (backup/restore)	An error has been detected in a backup or restore operation using the Memory Cassette. Refer to <i>13-2-1 Fatal Errors</i> to remove the error.

**Non-fatal Error Detected**

The G9SP-series Controller has detected an error for which operation can continue. Refer to *13-2 Error Details and Measures* to remove the error.

**13-1-3 Identifying Errors**

Next, read the details of the error using the G9SP Configurator or Option Board communications.

**Reading Error Details with the G9SP Configurator**

Check the present errors or error log using the procedures given in *10-1-1 Device Monitor*.

**Reading Error Details with Option Board Communications**

Check the present errors or error log using the procedures given in *SECTION 7 Communications with a Standard PLC Using an Option Board*.

## 13-2 Error Details and Measures

This section describes how to troubleshoot errors that occur in the G9SP-series Controller.

### 13-2-1 Fatal Errors

#### System Errors

Error name	Probable cause	Action
System failure	1. A hardware error has been detected in hardware self-diagnosis. 2. A memory error due to, for example, a software error has been detected.	Cycle the power supply. If the error occurs again, replace the Unit.
Internal NVS access error	An error has been detected when writing the internal NVS.	Cycle the power supply. If the error occurs again, replace the Unit.

#### Unit Configuration Errors

Error name	Probable cause	Action
Unsupported Expansion I/O Unit	The G9SP-series Controller was started with an unsupported Expansion I/O Unit connected.	With the power supply OFF, adjust the system to the proper Unit configuration, and then turn ON the power supply again.
Expansion I/O Unit maximum connection number exceeded	The G9SP-series Controller was started with three or more Expansion I/O Units connected.	With the power supply OFF, adjust the system to the proper Unit configuration, and then turn ON the power supply again.
Unsupported Option Board	The G9SP-series Controller was started with an unsupported Option Board mounted. (In particular, only unit version 2.0 or later of the CP1W-CIF41 Ethernet Option Board is supported.)	With the power supply OFF, adjust the system to the proper Unit configuration, and then turn ON the power supply again.

#### Force-set/reset Errors

Error name	Probable cause	Action
Force Mode timeout	The Force Mode has timed out and program execution has stopped.	---

#### Memory Cassette Errors

The G9SP-series Controller may perform a Memory Cassette operation if it is started with a Memory Cassette inserted or with DIP switch pin 4 set to ON. If an error is detected in that status, the ERR/ALM indicator will light red, and the terminal number will light red on the Safety Input terminal indicators to indicate error details.

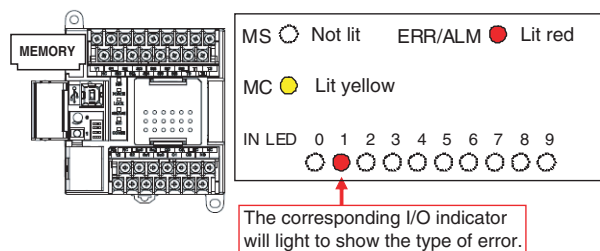

Error name	I/O LED	Probable cause	Action
Memory Cassette not inserted or incorrect Memory Cassette	Si1 lit red	<ol style="list-style-type: none"> <li>Backup was started with a Memory Cassette not inserted or not inserted securely.</li> <li>The G9SP-series Controller was started in Restore Mode with a Memory Cassette formatted using the CP1□ or a Memory Cassette containing incorrectly formatted data.</li> </ol>	<p>Restoring Data:</p> <ol style="list-style-type: none"> <li>With the power supply OFF, insert a Memory Cassette securely, and then turn ON the power supply again.</li> <li>With the power supply OFF, insert the correct Memory Cassette, and then turn ON the power supply again.</li> </ol> <p>If the error occurs again after this measure is taken, replace the Memory Cassette or the G9SP-series Controller.</p> <p>Not Restoring Data:</p> <p>The G9SP-series Controller will attempt to restore data if it is waiting for configuration (i.e., default status) or the configuration data that is held does not match data on the Memory Cassette. If restoring the data is not required, remove the Memory Cassette and cycle the power supply.</p>
Memory Cassette removed or access error	Si2 lit red	<ol style="list-style-type: none"> <li>The Memory Cassette was removed during execution of a Memory Cassette operation.</li> <li>Hardware error in G9SP-series Controller or Memory Cassette</li> </ol>	With the power supply OFF, insert the Memory Cassette again, and then turn ON the power supply again. If the error occurs again, replace the G9SP-series Controller or Memory Cassette.
Internal NVS access error during execution of Memory Cassette functions	Si3 lit red	Controller hardware failure	Cycle the power supply. If the error occurs again, replace the Unit.
Model information (model and unit version) mismatch	Si4 lit red	The model information in the configuration data stored on the Memory Cassette does not match the model information in the G9SP-series Controller.	With the power supply OFF, insert the correct Memory Cassette, and then turn ON the power supply again.
Device password mismatch between restore Memory Cassette and unit	Si5 lit red	The Device Password stored in the Memory Cassette does not match the Device Password in the G9SP-series Controller.	With the power supply OFF, insert the correct Memory Cassette, and then turn ON the power supply again.
Restore prohibit error	Si6 lit red	An attempt was made to restore data to a G9SP-series Controller for which restore prohibition has been set.	Using the G9SP Configurator, 1) overwrite the configuration data or 2) reset to the default settings, and then insert the Memory Cassette again and cycle the power supply.
Incorrect configuration data at restore	Si7 lit red	Incorrect data was detected when checking the configuration data stored in the Memory Cassette.	With the power supply OFF, insert the correct Memory Cassette, and then turn ON the power supply again.
Unconfigured Unit at backup	Si8 lit red	The G9SP-series Controller contains no configuration data, and so backup to the Memory Cassette cannot be performed.	---
Unlocked unit at backup error	Si9 lit red	The Controller's configuration data is not locked, and so backup to the Memory Cassette cannot be performed.	---



### Additional Information

Errors related to the Memory Cassette are not saved in the error log in the G9SP-series Controller's internal nonvolatile memory. Read and check the error before cycling the power supply.

### 13-2-2 Non-fatal Errors

#### Expansion I/O Unit Errors

Error name	Probable cause	Action
Expansion I/O Unit configuration mismatch	The system started with a configuration different from configuration set using the G9SP Configurator.	With the power supply OFF, adjust the system to the proper Unit configuration, and then turn ON the power supply again.
Expansion I/O bus error	Failure occurred when refreshing the Expansion I/O Unit. (The failure was the result of Expansion I/O Unit failure, improper contact, or noise interference.)	With the power supply OFF, check the connection to the Expansion I/O Unit. If the error occurs again, replace the Expansion I/O Unit or take measures against noise.

#### Program Execution Errors

Error name	Probable cause	Action
Function block status error	A logic error was detected in function block execution.	Refer to the <i>G9SP-N□□□ Safety Controller Instructions Reference Manual</i> (Cat. No. Z923).

#### Option Board Communications Errors

Error name	Probable cause	Action
Option Board communications error, communications timeout	A timeout was detected in communications through the Option Board. (This includes disconnected communications cable, Option Board failure, improper contact, noise interference, communications partner failure, or communications partner status change.)	With the power supply OFF, check the connection to the Option Board. If the error occurs again, replace the Option Board, take measures against noise, or check the remote connection.
Option Board communications error, not mounted	The Option Board became loose after startup.	With the power supply OFF, check the connection to the Option Board, and then turn ON the power supply again.

#### Safety I/O Function Errors

If an error is detected in the self-diagnosis functions of Safety Input terminals, the ERR/ALM indicator on the G9SP-series Controller will flash red, and the relevant Safety I/O terminal indicator will light red or flash red.

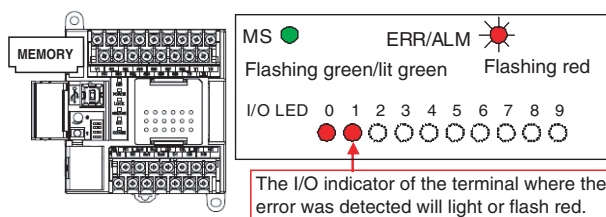

**Output Power Supply Errors**

<b>Error name</b>	<b>Probable cause</b>	<b>Action</b>
Output PS voltage low	The correct output power is not being supplied.	Check the following before supplying the rated power. <ul style="list-style-type: none"> <li>• Is the power supply voltage within the specifications?</li> <li>• Is the wiring correct or connected properly?</li> <li>• Either 24 V is not being applied to the Safety Output terminals or the power supply positive terminal is not connected.</li> </ul> The Unit may have failed if the measured voltage at terminal V2/G2 is normal. In that case, replace the Unit.
Output PS OFF circuit error	An error has been detected in the output power supply OFF test.	

**Safety Input Terminal Errors**

<b>Error name</b>	<b>Probable cause</b>	<b>Action</b>
External test signal failure at Safety Input	An error was detected in evaluation of Safety Input terminals. <ol style="list-style-type: none"> <li>1. Contact of input signal lines to positive side of power supply lines.</li> <li>2. Short-circuit between input signal lines.</li> <li>3. Failure of externally connected device.</li> </ol>	1./2. Check the external wiring. 3. Replace the externally connected device.
Internal circuit error at Safety Input	An error was detected in the internal circuits.	Cycle the power supply. If the error occurs again, replace the Unit.
Discrepancy error at Safety Input	An error was detected in discrepancy evaluation of Safety Input terminals. <ol style="list-style-type: none"> <li>1. Input signal line ground fault or disconnection.</li> <li>2. Failure of connected device.</li> <li>3. Incorrect set value for discrepancy time.</li> </ol>	1. Check the external wiring. 2. Replace the externally connected device. 3. Review the discrepancy time.

**Test Output Terminal Errors**

<b>Error name</b>	<b>Probable cause</b>	<b>Action</b>
Overload detected at Test Output	<ol style="list-style-type: none"> <li>1. Output signal line ground fault</li> <li>2. Failure of externally connected device.</li> </ol>	<ol style="list-style-type: none"> <li>1. Check the external wiring.</li> <li>2. Replace the externally connected device.</li> </ol>
Stuck-at-high detected at Test Output	<ol style="list-style-type: none"> <li>1. Contact of output signal lines to positive side of power supply lines.</li> <li>2. Internal circuit failure</li> </ol>	<ol style="list-style-type: none"> <li>1. Check the external wiring.</li> <li>2. Cycle the power supply. If the error occurs again, replace the Unit.</li> </ol>
Undercurrent detected using Mut-ing Lamp	<ol style="list-style-type: none"> <li>1. Output signal line disconnection.</li> <li>2. Failure of externally connected device.</li> </ol>	<ol style="list-style-type: none"> <li>1. Check the external wiring.</li> <li>2. Replace the externally connected device.</li> </ol>
Internal circuit error at Test Output	An error was detected in the internal circuits.	Cycle the power supply. If the error occurs again, replace the Unit.

**Safety Output Terminal Errors**

<b>Error name</b>	<b>Probable cause</b>	<b>Action</b>
Overcurrent detected at Safety Output	Failure of an externally connected device was detected.	Replace the externally connected device.
Short circuit detected at Safety Output	A ground fault in output signal lines was detected.	Check the external wiring.
Stuck-at-high detected at Safety Output	<ol style="list-style-type: none"> <li>1. Contact of output signal lines to positive side of power supply lines.</li> <li>2. Internal circuit failure</li> <li>3. Output power supply outside of specifications.</li> </ol>	<ol style="list-style-type: none"> <li>1. Check the external wiring.</li> <li>2. Cycle the power supply. If the error occurs again, replace the Unit.</li> <li>3. Check the output power supply.</li> </ol>
Dual channel violation at Safety Output	Programming error	Correct the program so that the same data is output when the Safety Output terminals are set to Dual-channel Mode.
Internal circuit error at Safety Output	An error was detected in the internal circuits.	Cycle the power supply. If the error occurs again, replace the Unit.

# Appendix A

## Application Templates

### Emergency Stop Pushbutton Application

Safety category/PL	Safety device	Stop category	Reset
Equivalent to 4/PLe.	Emergency stop pushbutton	0	Manual

#### Application Overview

Motor M stops when emergency stop pushbutton S1 is pressed.

#### Wiring Example

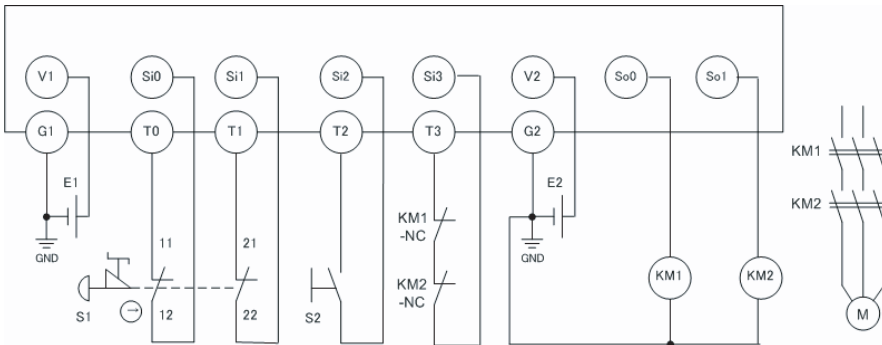

E1 and E2: 24-VDC power supplies  
 S1: Emergency stop pushbutton  
 S2: Reset switch  
 KM1 and KM2: Contactors  
 M: Motor

**Note** Refer to *SECTION 2 Part Names and Specifications* for the terminal arrangement.

#### Timing Chart

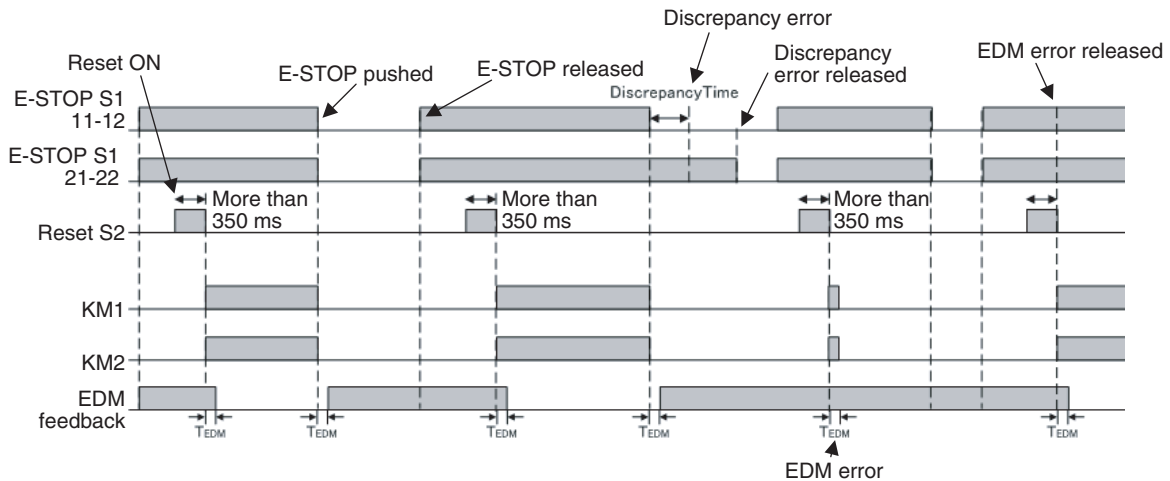

### Safety I/O Terminal Settings

**Input Terminals**

Ter...	Name of settings	I/O Comment	Test Source
S0	Emergency Stop S...	EMO NC S1 11-12	T0
S1		EMO NC S1 21-22	T1
S2	Reset Switch	Reset S2	T2
S3	EDM(Contact Weld...	Feedback KM1_KM2...	T3

**Output Terminals**

Ter...	Name of settings	I/O Comment
So0	2 Safety Relays w/ welding...	contactor KM1
So1		contactor KM2

### Program

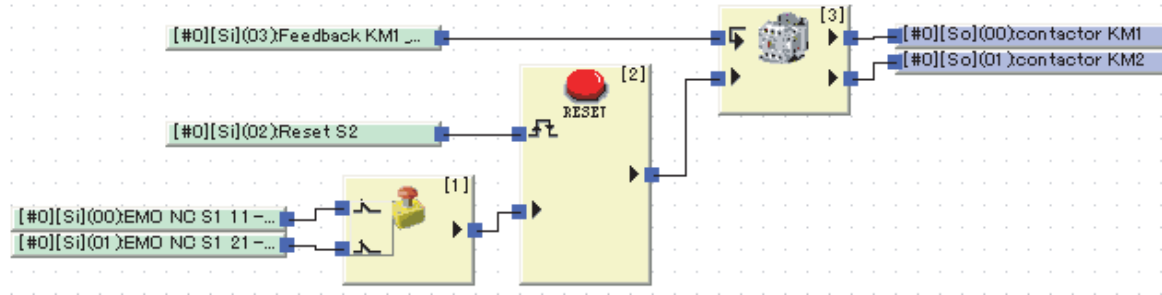

#### Precautions for Safe Use

Perform a function test every six months to detect contact welding failures on contactors.

It is the user's responsibility to make sure that the entire system complies with standards.

For safety reasons, two electrical switching elements and two mechanical actuators are always necessary to detect electrical faults and mechanical faults.



### Safety Door Application 1

Safety category/PL	Safety device	Stop category	Reset
Equivalent to 4/PLe.	Safety limit switch	0	Auto

#### Application Overview

Motor M stops when safety gate 1 (S1, S2) is opened.

#### Wiring Example

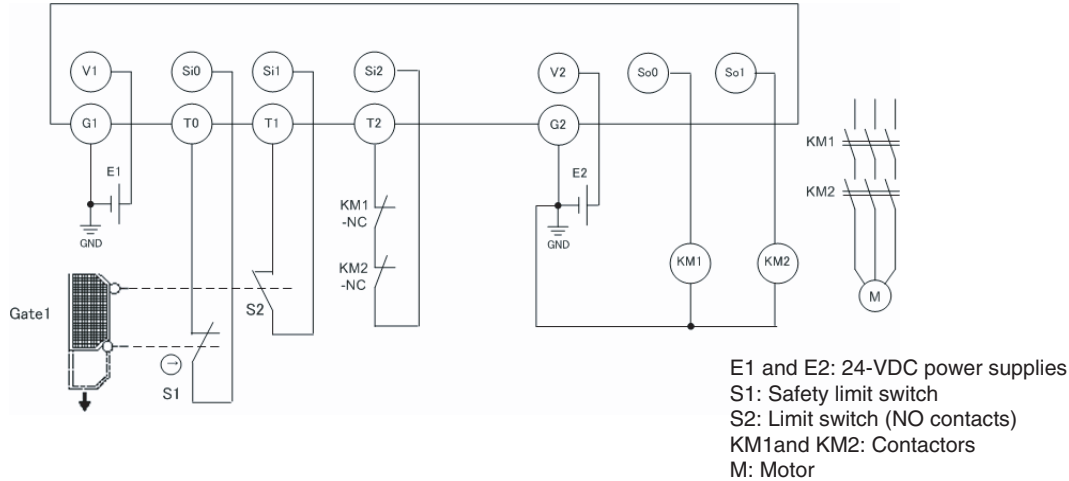

**Note** Refer to SECTION 2 Part Names and Specifications for the terminal arrangement.

#### Timing Chart

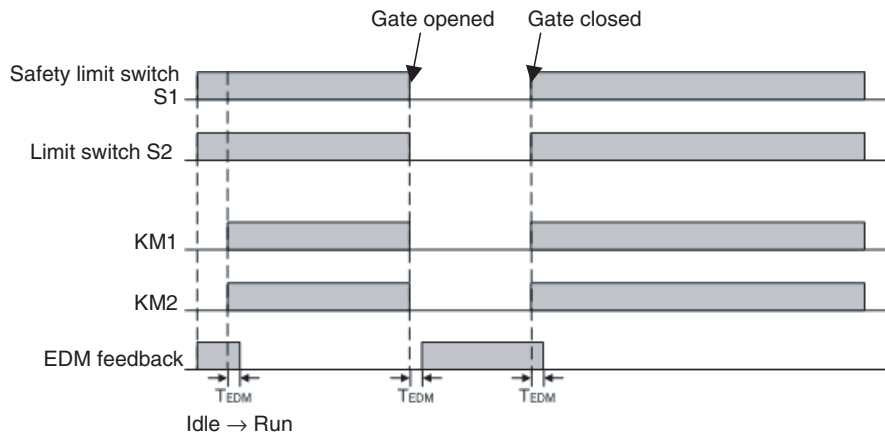

#### Safety I/O Terminal Settings

##### Input Terminals

Ter...	Name of settings	I/O Comment	Test Source
Si0	Safety Switch(2NC)	Door SW NC S1	T0
Si1		Door SW NC S2	T1
Si2	EDM(Contact Wel...	Feedback KM1_KM2...	T2

##### Output Terminals

Ter...	Name of settings	I/O Comment
So0	2 Safety Relays w/ welding ...	contactor KM1
So1		contactor KM2

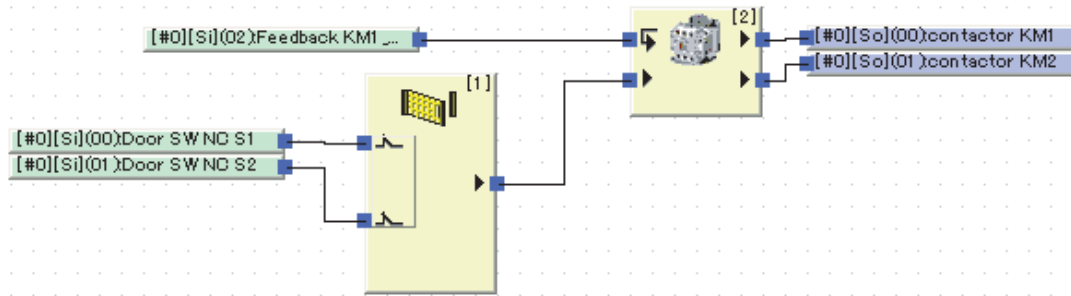
**Program****Precautions for Safe Use**

Perform a function test every six months to detect contact welding failures on contactors.

It is the user's responsibility to make sure that the entire system complies with standards.

For safety reasons, two electrical switching elements and two mechanical actuators are always necessary to detect electrical faults and mechanical faults.

### Safety Door Application 2

Safety category/PL	Safety device	Stop category	Reset
Equivalent to 4/PLe.	Safety limit switches 1 and 2	0	Auto
	Emergency stop pushbutton	0	Manual

#### Application Overview

M1 stops when safety gate 1 (S3, S4) is opened.  
 M2 stops when safety gate 2 (S5, S6) is opened.  
 Both M1 and M2 stop when the emergency stop pushbutton S1 is pressed.

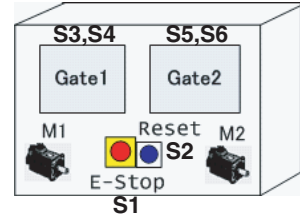

#### Wiring Example

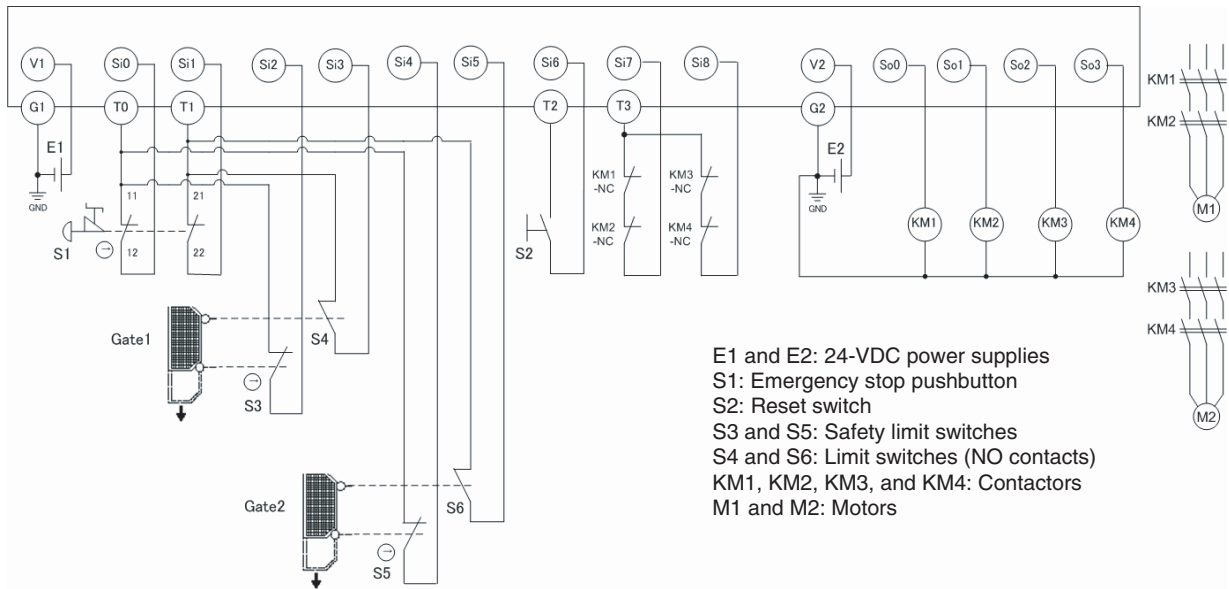

**Note** Refer to *SECTION 2 Part Names and Specifications* for the terminal arrangement.

#### Timing Chart

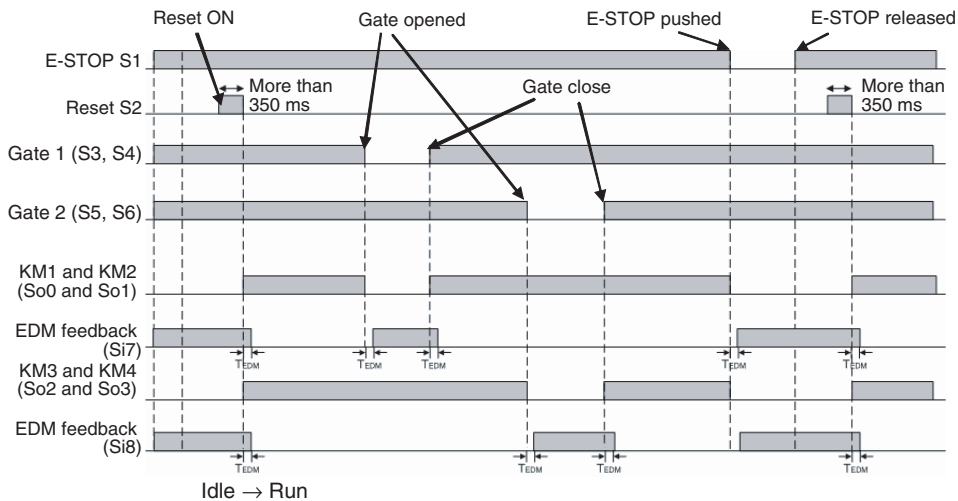

### Safety I/O Terminal Settings

**Input Terminals**

Ter...	Name of settings	I/O Comment	Test Source
Si0	Emergency Stop Sw...	EMO NC S1 11-12	T0
Si1		EMO NC S1 21-22	T1
Si2	Safety Switch(2NC)	Door SW NC S3	T0
Si3		Door SW NC S4	T1
Si4	Safety Switch(2NC)	Door SW NC S5	T0
Si5		Door SW NC S6	T1
Si6	Reset Switch	Reset S2	T2
Si7	EDM(Contact Weldi...	Feedback KM1_KM...	T3
Si8	EDM(Contact Weldi...	Feedback KM3_KM...	T3

**Output Terminals**

Ter...	Name of settings	I/O Comment
So0	2 Safety Relays w/ welding ...	contactor KM1
So1		contactor KM2
So2	2 Safety Relays w/ welding ...	contactor KM3
So3		contactor KM4

### Program

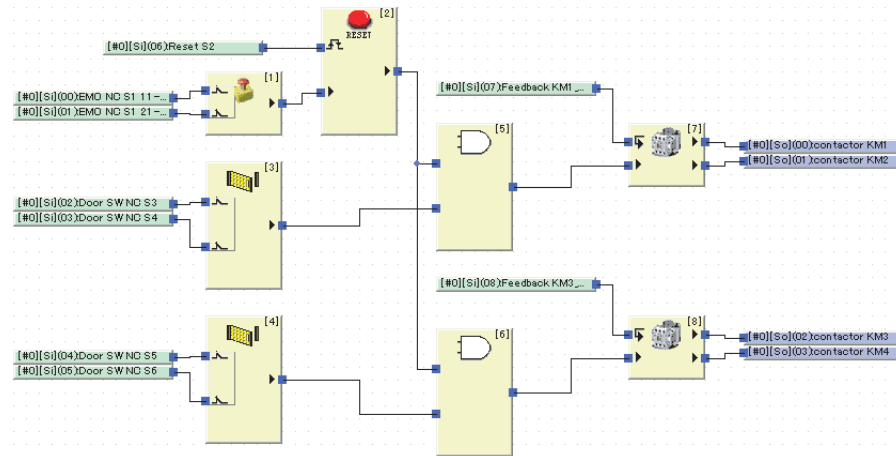

#### Precautions for Safe Use

Perform a function test every six months to detect contact welding failures on contactors. It is the user's responsibility to make sure that the entire system complies with standards. For safety reasons, two electrical switching elements and two mechanical actuators are always necessary to detect electrical faults and mechanical faults.

### Safety Light Current Application 1

Safety category/PL	Safety device	Stop category	Reset
Equivalent to 4/PLe.	<ul style="list-style-type: none"> <li>Emergency stop pushbutton</li> <li>Safety light curtain 1 (to detect human bodies)</li> <li>Safety light curtain 2 (to detect hazards)</li> </ul>	0	Manual

#### Application Overview

The output goes OFF when light is intercepted for both safety light curtain 1 (S2) and safety light curtain 2 (S3) simultaneously.

The output also goes OFF when emergency stop pushbutton S1 is pressed.

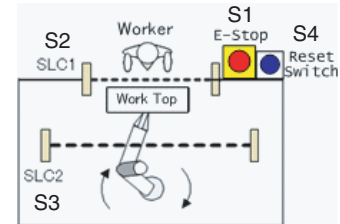

#### Wiring Example

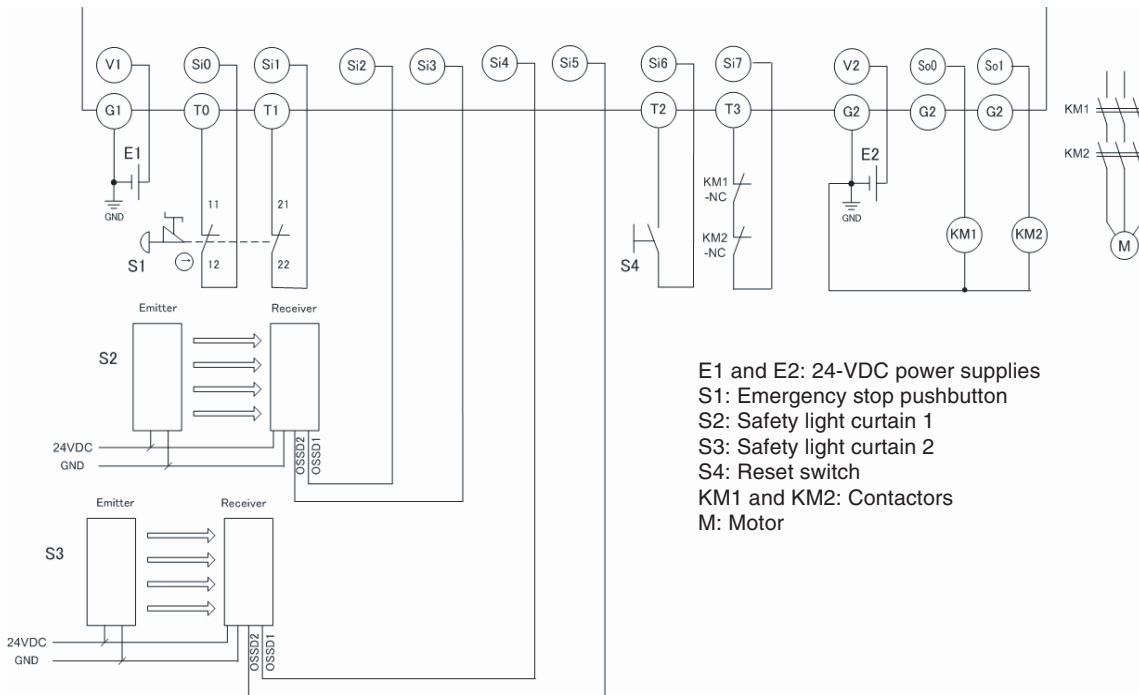

**Note** Refer to SECTION 2 Part Names and Specifications for the terminal arrangement.

### Timing Chart

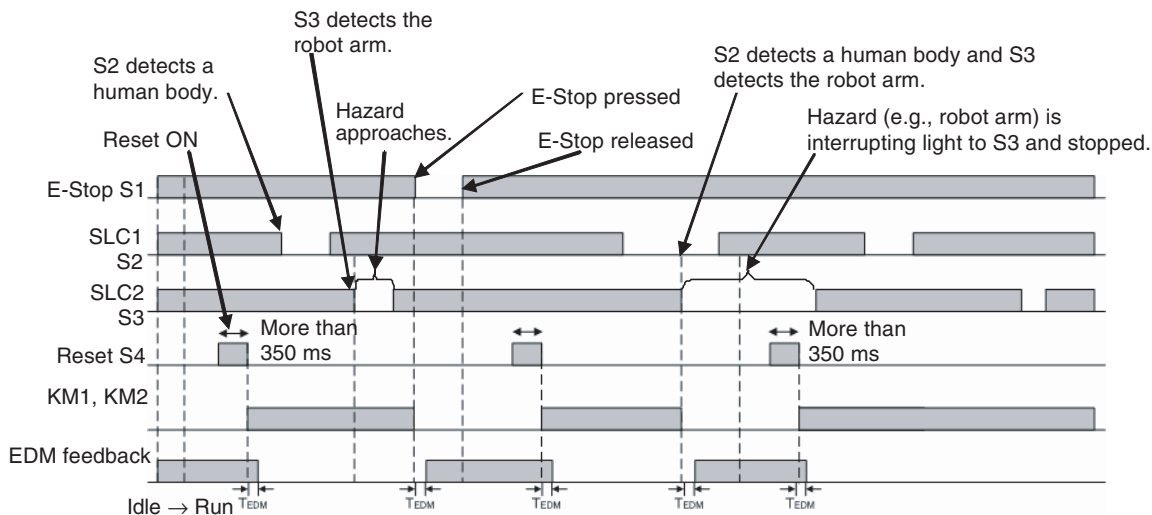

### Safety I/O Terminal Settings

Input Terminals

Ter...	Name of settings	I/O Comment	Test Source
S10	Emergency Stop S...	EMO NC S1 11-12	T0
S11		EMO NC S1 21-22	T1
S12	Light Curtain	SLC1 S2	
S13		SLC1 S2	
S14	Light Curtain	SLC2 S3	
S15		SLC2 S3	
S16	Reset Switch	Reset S4	T2
S17	EDM(Contact Wel...	Feedback KM1_KM2...	T3

Output Terminals

Ter...	Name of settings	I/O Comment
So0	2 Safety Relays w/ welding ...	contactor KM1
So1		contactor KM2

### Program

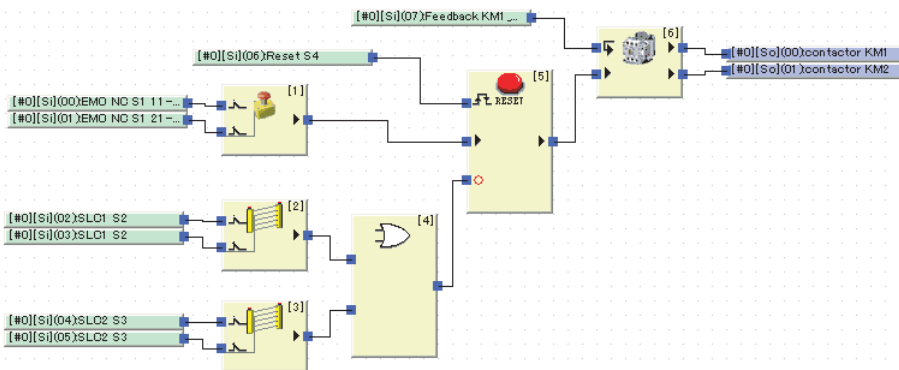

#### Precautions for Safe Use

Perform a function test every six months to detect contact welding failures on contactors. It is the user's responsibility to make sure that the entire system complies with standards. For safety reasons, two electrical switching elements and two mechanical actuators are always necessary to detect electrical faults and mechanical faults.

### Safety Light Curtain Application 2

Safety category/PL	Safety device	Stop category	Reset
Equivalent to 4/PLe.	<ul style="list-style-type: none"> <li>• Emergency stop pushbutton</li> <li>• Safety light curtain (to detect human bodies)</li> <li>• Safety limit switch (to detect hazards)</li> </ul>	0	Manual

#### Application Overview

The output goes OFF when light is intercepted for the safety light curtain and the safety limit switch turns OFF simultaneously.

The output also goes OFF when emergency pushbutton S1 is pressed.

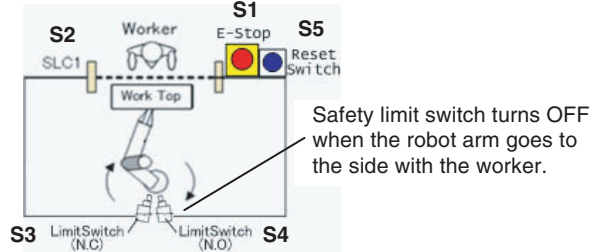

#### Wiring Example

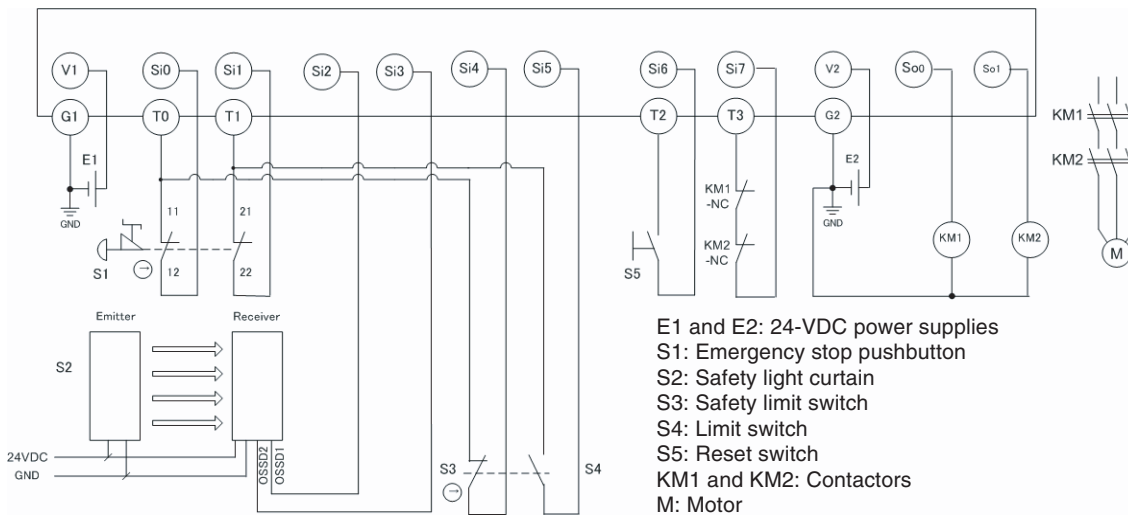

**Note** Refer to SECTION 2 Part Names and Specifications for the terminal arrangement.

### Timing Chart

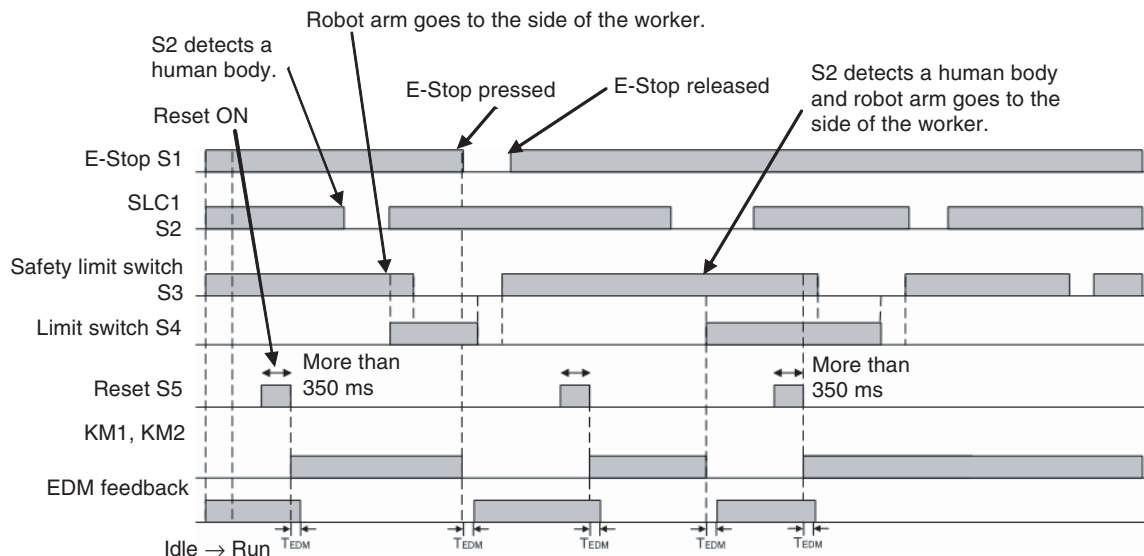

### Safety I/O Terminal Settings

Input Terminals

Ter...	Name of settings	I/O Comment	Test Source
S10	Emergency Stop S...	EMO NC S1 11-12	T0
S11		EMO NC S1 21-22	T1
S12	Light Curtain	SLC1 S2	
S13		SLC1 S2	
S14	Safety Switch(1NC/...	Limit SW NC S3	T0
S15		Limit SW NC S4	T1
S16	Reset Switch	Reset S5	T2
S17	EDM(Contact Weldi...	Feedback KM1_KM2...	T3

Output Terminals

Ter...	Name of settings	I/O Comment
So0	2 Safety Relays w/ welding ...	contactort KM1
So1		contactort KM2

### Program

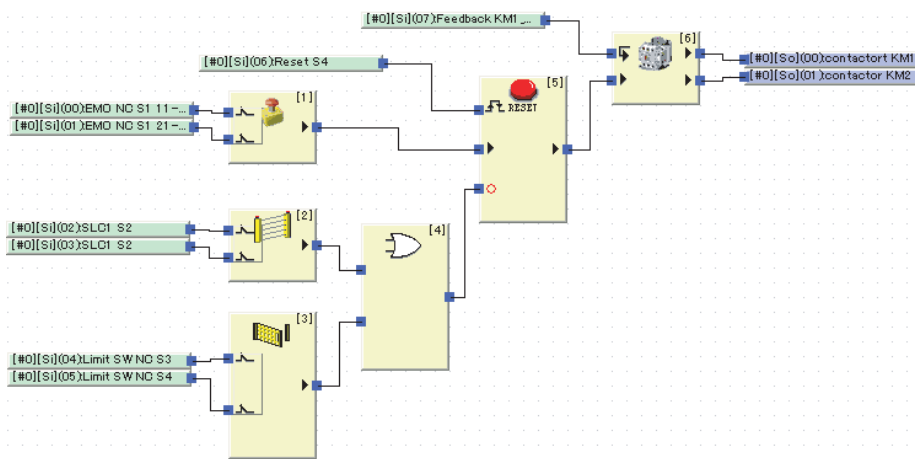

#### Precautions for Safe Use

Perform a function test every six months to detect contact welding failures on contactors. It is the user's responsibility to make sure that the entire system complies with standards. For safety reasons, two electrical switching elements and two mechanical actuators are always necessary to detect electrical faults and mechanical faults.



## Application for Safety Door Switch with Magnetic Lock and User Mode Switch

Safety category/PL	Safety device	Stop category	Reset
Equivalent to 4/PLe.	<ul style="list-style-type: none"> <li>Emergency stop pushbutton</li> <li>Safety door switch with magnetic lock (mechanical lock type)</li> <li>User mode switch</li> </ul>	0	Manual

### Application Overview

When the user mode is normal operation, the safety gate (S2, S3) cannot be opened. The outputs will be turned OFF by switching to maintenance mode, and after 5 s it will be possible to open the safety gate. The outputs also go OFF when emergency pushbutton S1 is pressed.

### Wiring Example

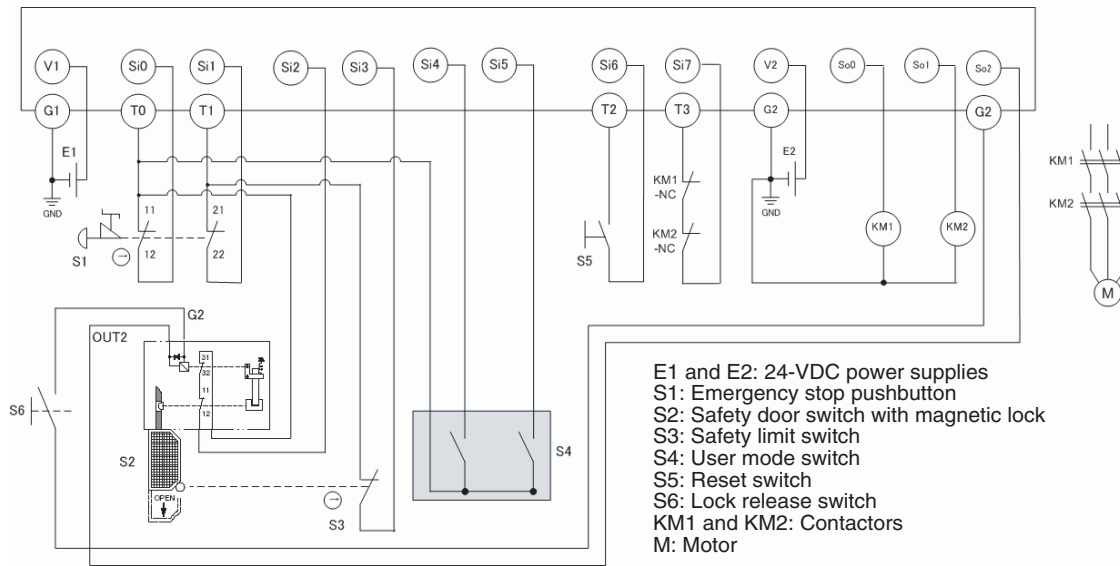

**Note** Refer to *SECTION 2 Part Names and Specifications* for the terminal arrangement.

### Timing Chart

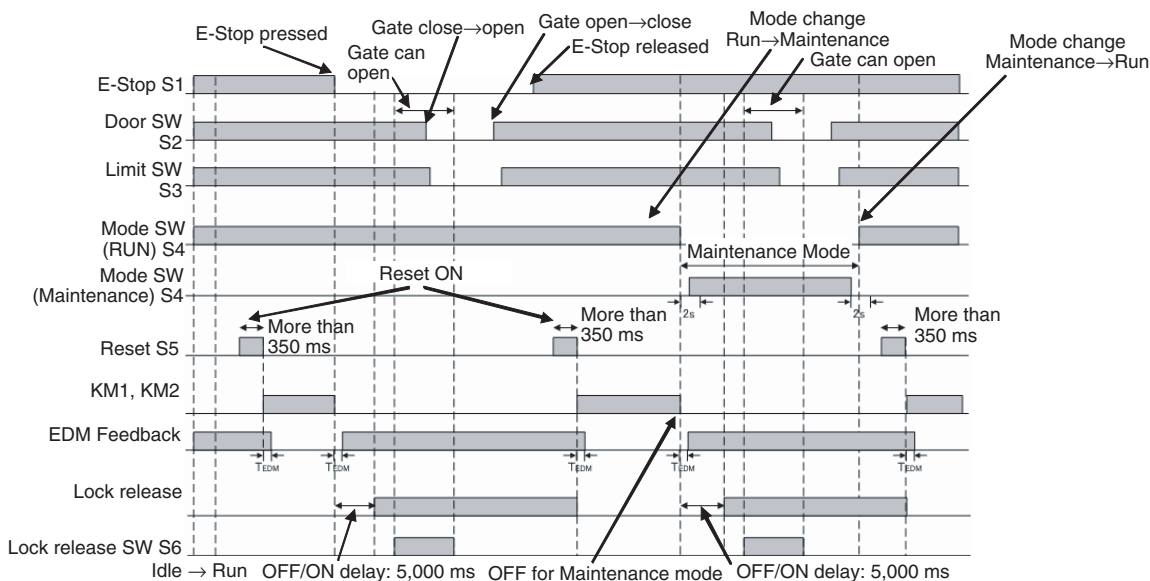

### Safety I/O Terminal Settings

**Input Terminals**

Ter...	Name of settings	I/O Comment	Test Source
Si0	Emergency Stop S...	EMO NC S1 11-12	T0
Si1		EMO NC S1 21-22	T1
Si2	Safety Switch(2NC)	Door SW NC S2	T0
Si3		Door SW NC S3	T1
Si4	Single Contact(1NC)	Mode SW S4-RUN ...	T0
Si5	Single Contact(1NC)	Mode SW S4-Mainte...	T0
Si6	Reset Switch	Reset S5	T2
Si7	EDM(Contact Weld...	Feedback KM1_KM2...	T3

**Output Terminals**

Ter...	Name of settings	I/O Comment
So0	2 Safety Relays w/ welding ...	contactor KM1
So1		contactor KM2
So2	Single Safety PNP Output w...	Door Lock Release

### Program

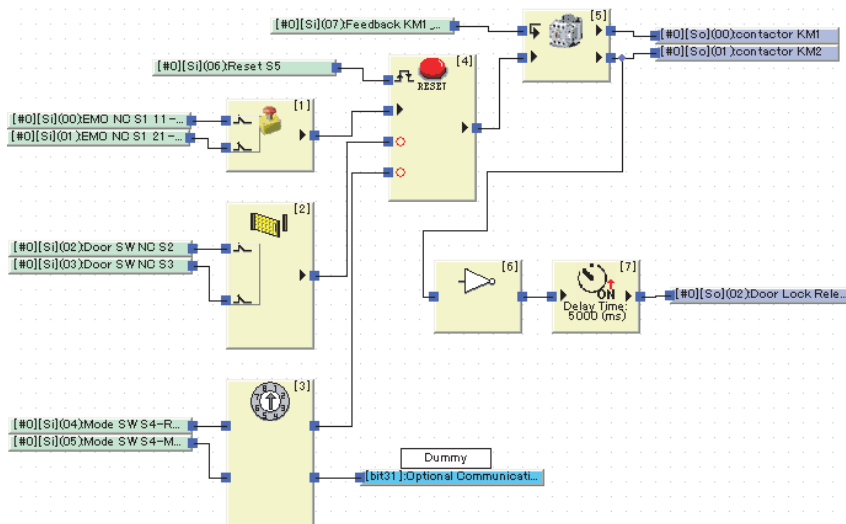

### Precautions for Safe Use

Perform a function test every six months to detect contact welding failures on contactors. It is the user's responsibility to make sure that the entire system complies with standards. For safety reasons, two electrical switching elements and two mechanical actuators are always necessary to detect electrical faults and mechanical faults.

### D40A Non-Contact Switch Application

Safety category/PL	Safety device	Stop category	Reset
Equivalent to 3/PLd.	<ul style="list-style-type: none"> <li>Emergency stop pushbutton</li> <li>D40A Non-contact Switch</li> </ul>	0	Manual

#### Application Overview

Motor M stops when emergency stop pushbutton S1 is pressed.

Motor M is stopped by opening the connection with the safety door (D40A No-contact Switch) at S2.

#### Wiring Example

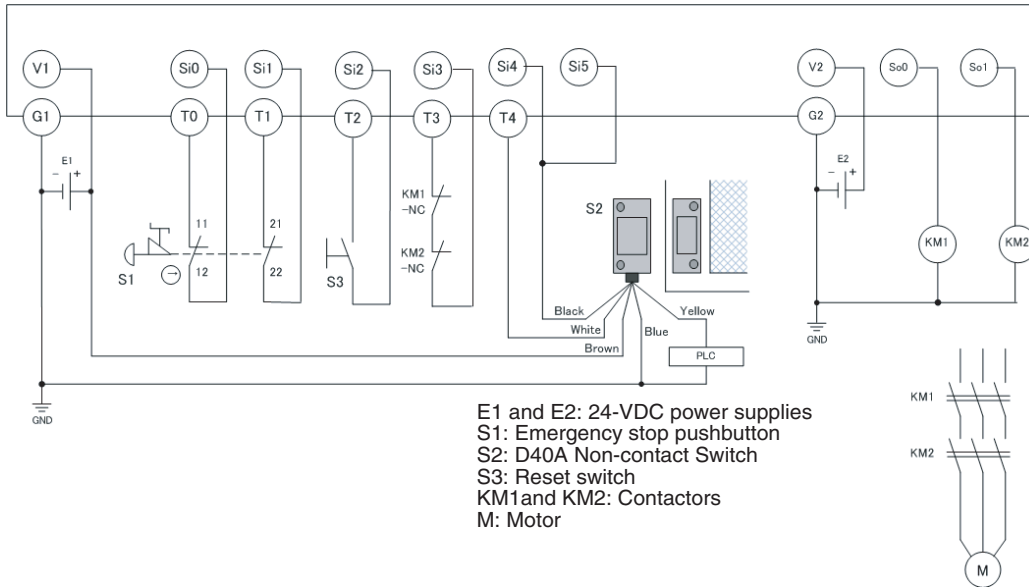

**Note** Refer to SECTION 2 Part Names and Specifications for the terminal arrangement.

#### Timing Chart

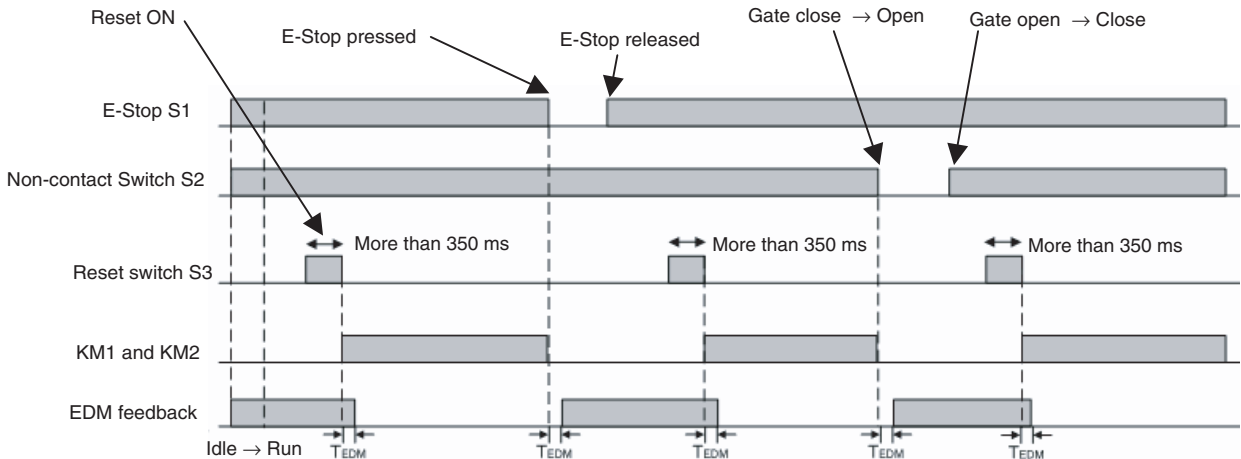

### Safety I/O Terminal Settings

**Input Terminals**

Ter...	Name of settings	I/O Comment	Test Source
Si0	Emergency Stop Sw...	EMO NC S1 11-12	T0
Si1		EMO NC S1 21-22	T1
Si2	Reset Switch	Reset S3	T2
Si3	EDM(Contact Weldi...	Feedback KM1_KM2	T3
Si4	Non-contact Switch	Non-contact Switch...	T4
Si5		Non-contact Switch...	T4

**Output Terminals**

Ter...	Name of settings	I/O Comment
So0	2 Safety Relays w/ welding ...	contactor KM1
So1		contactor KM2

### Program

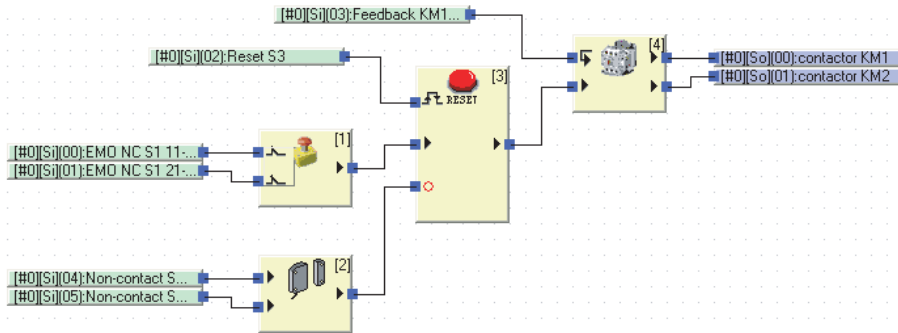

#### Precautions for Safe Use

Perform a function test every six months to detect contact welding failures on contactors. It is the user's responsibility to make sure that the entire system complies with standards. For safety reasons, two electrical switching elements and two mechanical actuators are always necessary to detect electrical faults and mechanical faults.

### D40Z Non-Contact Switch Application

Safety category/PL	Safety device	Stop category	Reset
Equivalent to 4/PLe.	<ul style="list-style-type: none"> <li>Emergency stop pushbutton</li> <li>D40Z Non-contact Switch</li> </ul>	0	Manual

#### Application Overview

Motor M stops when emergency stop pushbutton S1 is pressed.

Motor M is stopped by opening the connection with the safety door (D40Z No-contact Switch) at S2.

#### Wiring Example

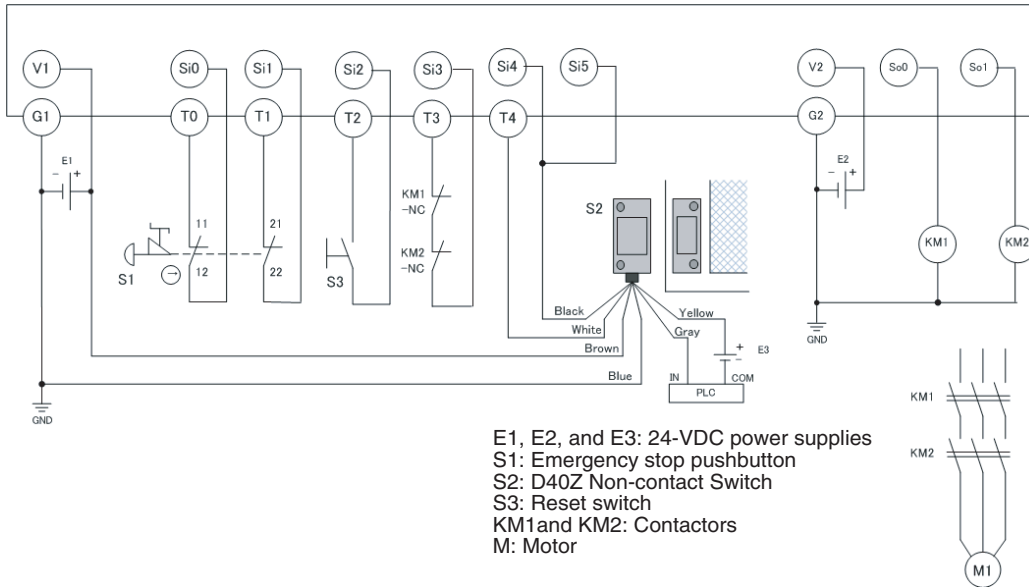

**Note** Refer to SECTION 2 Part Names and Specifications for the terminal arrangement.

#### Timing Chart

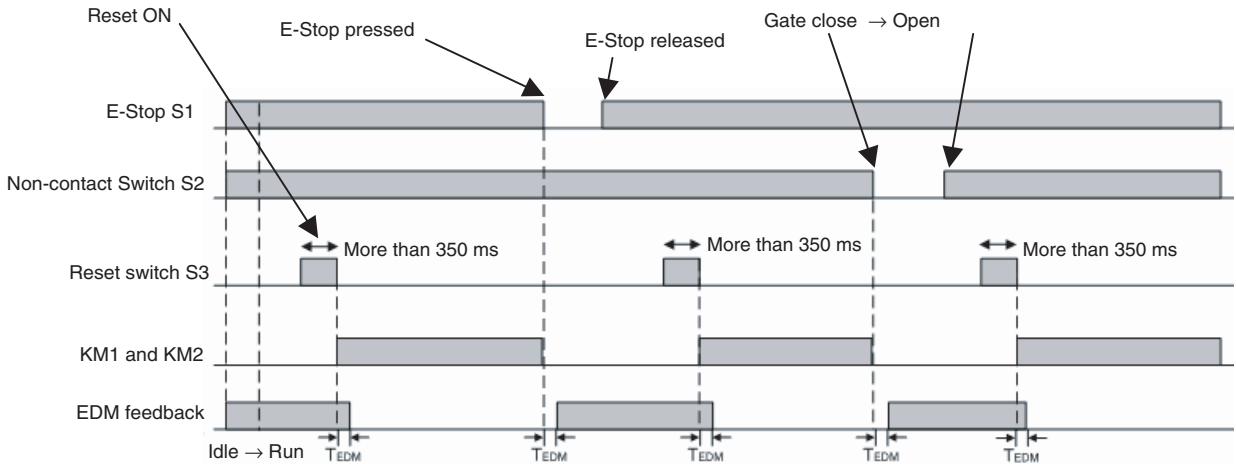

### Safety I/O Terminal Settings

Input Terminals

Ter...	Name of settings	I/O Comment	Test Source
Si0	Emergency Stop Sw...	EMO NC S1 11-12	T0
Si1		EMO NC S1 21-22	T1
Si2	Reset Switch	Reset S3	T2
Si3	EDM(Contact Weldi...	Feedback KM1_KM2	T3
Si4	Non-contact Switch	Non-contact Switch...	T4
Si5		Non-contact Switch...	T4

Output Terminals

Ter...	Name of settings	I/O Comment
So0	2 Safety Relays w/ welding ...	contactor KM1
So1		contactor KM2

### Program

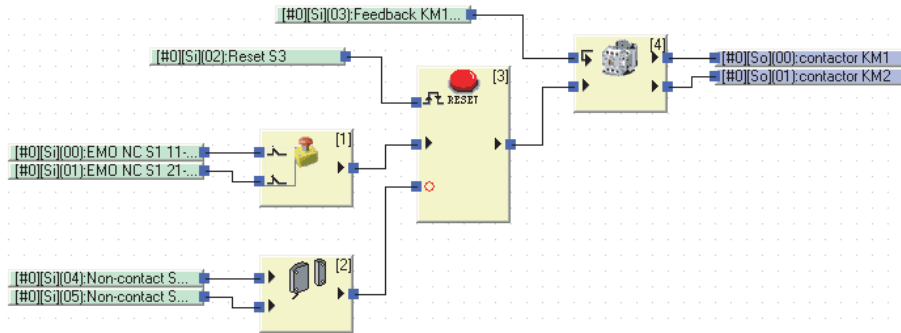

#### Precautions for Safe Use

Perform a function test every six months to detect contact welding failures on contactors. It is the user's responsibility to make sure that the entire system complies with standards. For safety reasons, two electrical switching elements and two mechanical actuators are always necessary to detect electrical faults and mechanical faults.

# Appendix B

## Using the Password Recovery Tool

If the device password set in the G9SP-series Controller is lost, use the Password Recovery Tool to reset the password and to return to the state without any password setting (default settings).

Use the following procedure to reset a device password.

1. Prepare the computer for connecting to the G9SP-series Controller via the USB port.
2. Select **Program - OMRON G9SP Configurator - Password Recovery Tool** (when using the default program folder names) from the Start Menu.
3. The Password Recovery Tool will start. Click the **Connect to Device** Button to connect online to the G9SP-series Controller.

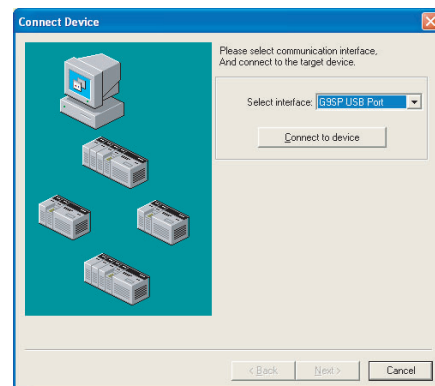

4. The necessary information for resetting the password will be displayed as shown at the right. The information is required when inquiring from the Support Center. Print the information by outputting to a text file and or copying to another application using the clipboard.

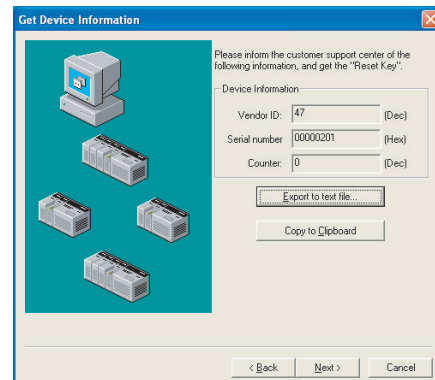

5. Click the **Next** Button to display the Reset Key Enter Window. Enter the Reset Key obtained from the Support Center and click the **Reset** Button.

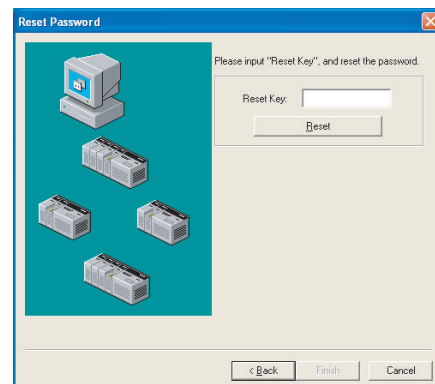

6. If the password is successfully reset, a message will appear saying that the password has been initialized. The device will be returned to the state without any password setting (default setting). Click the **OK** Button to close the dialog box. Click the **Finish** Button in the Password Recovery Tool Window to exit.





# Appendix C

## Calculated Values of PFD and PFH

Calculated values of PFD and PFH of the G9SP-series Controller are given in the following tables. These values must be calculated for the overall devices within the system to comply with the SIL level required for application.

### Meaning of PFD and PFH

PFD	PFD stands for “probability of failure on demand.” PFD expresses the average probability of failure of a system or device when it is demanded. This value is used to calculate the safety integrity level (SIL) of a safety system.
PFH	PFH stands for “probability of failure per hour.” PFH expresses the probability of failure per hour for a system or device. This value is used to calculate the safety integrity level (SIL) of a safety system.

### Calculated PFD Values

Proof test interval (years)	PFD		
	G9SP-N10S	G9SP-N10D	G9SP-N20S
0.25	8.86E-08	1.13E-07	9.71E-08
0.5	1.74E-07	2.22E-07	1.90E-07
1	3.44E-07	4.39E-07	3.77E-07
2	6.85E-07	8.75E-07	7.51E-07
5	1.71E-06	2.19E-06	1.88E-06
10	3.44E-06	4.40E-06	3.77E-06
20	6.94E-06	8.91E-06	7.62E-06

### Calculated PFH Values

PFH		
G9SP-N10S	G9SP-N10D	G9SP-N20S
7.80E-11	9.96E-11	8.55E-11



# Index

## B

backing up data, 150  
building program, 75

## C

configuration ID, 155  
configuration lock, 131  
configuration unlock, 132  
cycle time, 47, 76

## D

Device Monitor, 136  
device password, 78, 125  
diagnosis, 25, 33  
discrepancy time, 26  
dual channel evaluation, 26  
Dual Channel Mode, 33

## E

error log, 138

## F

Force Mode, 143  
force-set/force-reset, 143

## I

I/O comments, 72, 74  
I/O tags, 74  
input filters, 28

## J

Jump tag, 75

## M

Memory Cassette operations, 148

## O

OFF delay, 28  
ON delay, 28  
operation log, 139

## P

pages, 75  
parameter password, 78  
PFD/PFH, 187

## R

reaction time, 47  
reports, 77  
resetting, 124  
restore prohibition, 152  
restoring data, 152  
returning to the out-of-box configuration, 124

## S

Safety Input terminals, 72  
Safety Output terminals, 72  
safety response performance, 47  
safety signature, 155  
safety validation testing, 146  
single/dual setting, 26, 33  
system settings, 76

## T

Test Mode, 26  
test pulse evaluation, 25, 32  
test source, 25

## U

Unit Conduction Time, 138  
unit configuration, 71  
user testing, 146  
user-defined function blocks, 75

**V**

verification, 122

**W**

Watch Window, 141

## Revision History

A manual revision code appears as a suffix to the catalog number on lower left corners of the front and back covers of the manual.

Cat. No. Z922-E1-02



Revision code

The following table outlines the changes made to the manual during each revision. Page numbers refer to the previous version.

Revision code	Date	Revised content
01	June 2010	Original production
02	September 2010	Added D40Z No-contact Switch, added descriptions, and corrected mistakes.

---

---

*Revision History*

---

---



**OMRON Corporation** Industrial Automation Company  
Tokyo, JAPAN

Contact: [www.ia.omron.com](http://www.ia.omron.com)

**Regional Headquarters**

**OMRON EUROPE B.V.**

Wegalaan 67-69-2132 JD Hoofddorp  
The Netherlands

Tel: (31)2356-81-300/Fax: (31)2356-81-388

**OMRON SCIENTIFIC TECHNOLOGIES INC.**

6550 Dumbarton Circle, Fremont  
CA 94555-3605 U.S.A.

Tel: (1) 510-608-3400/Fax: (1) 510-744-1442

**OMRON ASIA PACIFIC PTE. LTD.**

No. 438A Alexandra Road # 05-05/08 (Lobby 2),  
Alexandra Technopark,  
Singapore 119967

Tel: (65) 6835-3011/Fax: (65) 6835-2711

**OMRON (CHINA) CO., LTD.**

Room 2211, Bank of China Tower,  
200 Yin Cheng Zhong Road,  
PuDong New Area, Shanghai, 200120, China  
Tel: (86) 21-5037-2222/Fax: (86) 21-5037-2200

**Authorized Distributor:**

© OMRON Corporation 2010 All Rights Reserved.  
In the interest of product improvement,  
specifications are subject to change without notice.

**Cat. No. Z922-E1-02**

Printed in Japan  
0910