

SGDH-□

# Sigma-II servo drive

**The ideal servo family for motion control. Fast response, high speed, and high accuracy.**

- Online autotuning with 10 levels of rigidity
- Peak torque 300% of nominal during 3 seconds
- Automatic motor recognition
- Analogue control for speed and torque
- Pulse train control for positioning
- Optional units offer network connectivity and flexible system architecture
- Smooth operation
- Oscilloscope available via software tool
- Windows based configuration and commissioning software



**Ratings**

- 230 VAC Single-phase 30 W to 1.5 kW (4.77 Nm)
- 400 VAC Three-phase 450 W to 55 kW (350 Nm)

**System configuration**

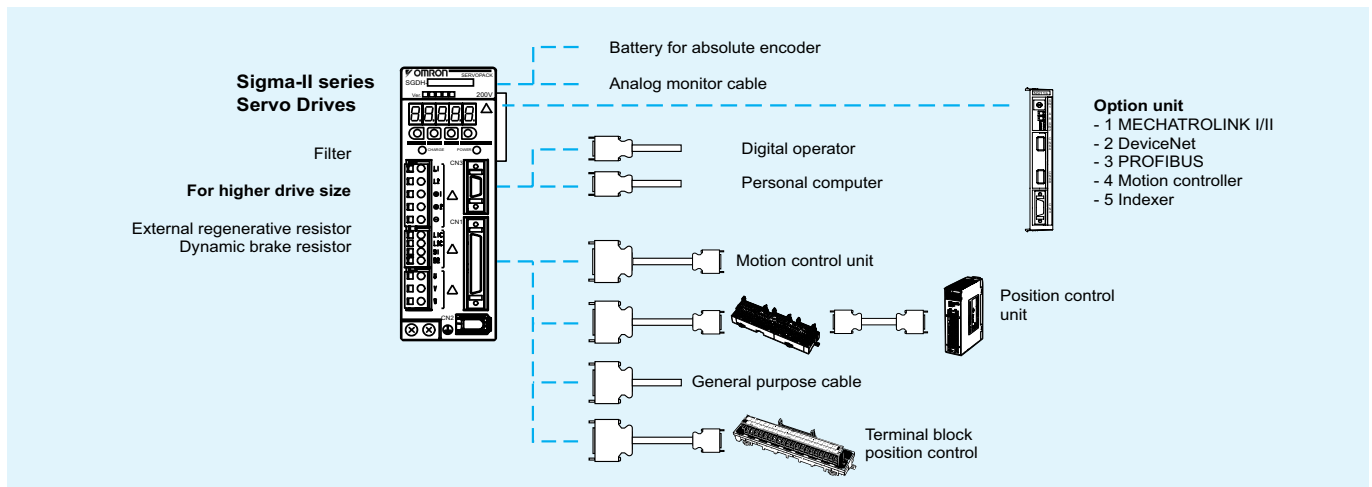



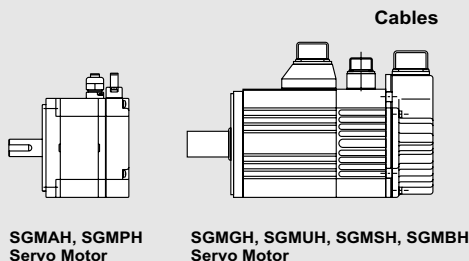



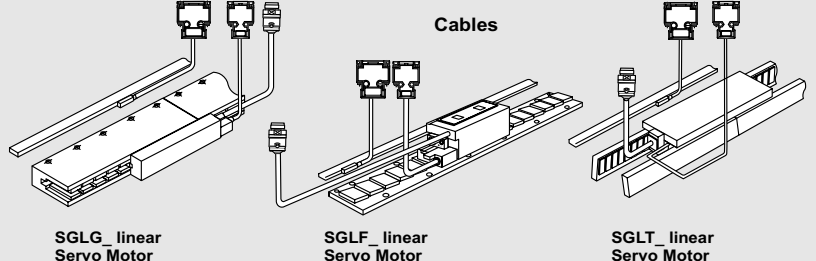

(Refer to chapter Sigma-II rotary motors)



(Refer to chapter Sigma-II linear motors)



Servo motor supported

Servo motor			
Family	Voltage	Models rated torque	Remarks
SGMAH (3000 min <sup>-1</sup> ) 	230 V	0.0955 Nm to 2.39 Nm	Refer to the Sigma-II rotary motors chapter for details
	400 V	0.955 Nm to 2.07 Nm	
SGMPH (3000 min <sup>-1</sup> ) 	230 V	0.318 Nm to 4.77 Nm	Refer to the Sigma-II rotary motors chapter for details
	400 V	0.637 Nm to 4.77 Nm	
SGMGH (1500 min <sup>-1</sup> ) 	400 V	2.84 Nm to 95.4 Nm	Refer to the Sigma-II Rrotary motors chapter for details
SGMSH (3000 min <sup>-1</sup> ) 	400 V	3.18 Nm to 15.8 Nm	Refer to the Sigma-II Rrotary motors chapter for details
SGMUH (6000 min <sup>-1</sup> ) 	400 V	1.59 Nm to 6.3 Nm	Refer to the Sigma-II rotary motors chapter for details
SGMBH (1500 min <sup>-1</sup> ) 	400 V	140 Nm to 350 Nm	Refer to the Sigma-II rotary motors chapter for details
SGLGW Linear motors 	230 V	12.5 N to 325 N	Refer to the Sigma linear motors chapter for details
SGLFW Linear motors 	230 V	25 N to 560 N	Refer to the Sigma linear motors chapter for details
	400 V	80 N to 2250 N	
SGLTW Linear motors 	400 V	300 N to 2000 N	Refer to the Sigma linear motors chapter for details

Type designation

Servo drive

**SGDH - 04 A E - S - OY**

Sigma-II servo drive

Capacity

A3	30 W	15	1.5 kW	2B	22 kW
A5	50 W	20	2.0 kW	3Z	30 kW
01	100 W	30	3.0 kW	3G	37 kW
02	200 W	50	5.0 kW	4E	45 kW
04	400 W	60	6.0 kW	5E	55 kW
05	500 W	75	7.5 kW		
08	750 W	1A	11 kW		
10	1.0 kW	1E	15 kW		

Phase

Blank	Three-phase (0.5 to 55kW) Single-phase (30 to 400W)
S	Single-phase (750W/1.5kW)

Model

E: speed, torque, position

Source voltage

A: 230 V

D: 400 V

Servo drive specifications

Single-phase, 230 V

Servo drive type		SGDH-□	A3AE-OY	A5AE-OY	01AE-OY	02AE-OY	04AE-OY	08AE-S-OY	15AE-S-OY	
Applicable servo motor	SGMAH-□	A3A□	A5A□	01A□	02A□	04A□	08A□	-		
	SGMPH-□	-	-	01A□	02A□	04A□	08A□	15A□		
Max. applicable motor capacity	W	30	50	100	200	400	750	1500		
Continuous output current	Arms	0.44	0.64	0.91	2.1	2.8	5.7	11.6		
Max. output current	Arms	1.3	2.0	2.8	6.5	8.5	13.9	28		
Input power	Main circuit	For single-phase, 200 to 230 VAC + 10 to -15%						220 to 230 VAC		
Supply	Control circuit	For single-phase, 200 to 230 VAC + 10 to -15%						+10 to -15% (50/60 Hz)		
Control method		Single phase full-wave rectification / IGBT / PWM / sine-wave current drive method								
Feedback		Serial encoder (incremental/absolute value)								
Conditions	Usage/storage temperature	0 to +55 °C / -20 to 85 °C								
	Usage/storage humidity	90%RH or less (non-condensing)								
	Altitude	1000m or less above sea level								
	Vibration/shock resistance	4.9 m/s <sup>2</sup> / 19.6 m/s <sup>2</sup>								
Configuration		Base mounted								
Approx. weight	Kg	0.8				1.1		1.7		3.8

Three-phase, 400 V (up to 15 kW)

Servo drive type		SGDH-□	05DE-OY	10DE-OY	15DE-OY	20DE-OY	30DE-OY	50DE-OY	60DE-OY	75DE-OY	1ADE-OY	1EDE-OY
Applicable servo motor	SGMGH-□	05D□	09D□	13D□	20D□	30D□	44D□	55D□	75D□	1AD□	1ED□	-
	SGMSH-□	-	10D□	15D□	20D□	30D□	40D□/50D□	-	-	-	-	-
	SGMUH-□	-	10D□	15D□	-	30D□	40D□	-	-	-	-	-
Max. applicable motor capacity	kW	0.45	1.0	1.5	2.0	3.0	5.0	6.0	7.5	11	15	-
Continuous output current	Arms	1.9	3.5	5.4	8.4	11.9	16.5	20.8	25.4	28.1	37.2	-
Max. output current	Arms	5.5	8.5	14	20	28	40.5	55	65	70	85	-
Input power	Main circuit	For three-phase, 380 to 480 VAC + 10 to -15% (50/60Hz)										
Supply	Control circuit	24 VDC+ 15%										
Control method		Three phase full-wave rectification / IGBT / PWM / sine-wave current drive method										
Feedback		Serial encoder (incremental/absolute)										
Conditions	Usage/storage temperature	0 to +55 °C / -20 to +85 °C										
	Usage/storage humidity	90%RH or less (non-condensing)										
	Altitude	1000 m or less above sea level										
	Vibration/shock resistance	4.9 m/s <sup>2</sup> / 19.6 m/s <sup>2</sup>										
Configuration		Base mounted										
Approx. weight	Kg	2.8			3.8		5.5		13.5		22	

Three-phase, 400 V (from 22 kW to 55 kW)

Servo drive type		SGDH-□	2BDE	3ZDE	3GDE	4EDE	5EDE
Applicable servo motor	SGMBH-□	2BD□A	3ZD□A	3GD□A	4ED□A	5ED□A	-
Max. applicable motor capacity	kW	22	30	37	45	55	-
Continuous output current	Arms	58	80	100	127	150	-
Max. output current	Arms	120	170	210	260	310	-
Input power	Main circuit	For three-phase, 380 to 480 VAC + 10 to -15% (50/60 Hz)					
Supply	Control circuit	24 VDC+ 15%					
Control method		Three phase full-wave rectification / IGBT / PWM / sine-wave current drive method					
Feedback		Serial encoder (incremental/absolute)					
Conditions	Usage/storage temperature	0 to +55 °C / -20 to +85 °C					
	Usage/storage humidity	90%RH or less (non-condensing)					
	Altitude	1000 m or less above sea level					
	Vibration/shock resistance	4.9 m/s <sup>2</sup> / 19.6 m/s <sup>2</sup>					
Configuration		Base mounted					
Approx. weight	Kg	40			60		65

General specifications

Speed/torque control mode	Performance	Speed control range		
		Speed variance	Load variance	1:5000
Input signal	Torque control accuracy (reproducibility)	Voltage variance	Rated voltage ±10%:0% (at rated speed)	
		Temperature variance	25 ±25 °C: ±0.1 % max (at rated speed)	
		Frequency characteristics	400 Hz (at J <sub>L</sub> = J <sub>M</sub> up to 15 kW drives), 100 Hz (at J <sub>L</sub> = J <sub>M</sub> from 22 kW to 55 kW drives)	
		Soft start time setting	0 to 10 s (acceleration, deceleration can each be set.)	
	Speed reference input	Reference voltage	±6 VDC (forward motor rotation if positive reference) at rated speed: set at delivery Variable setting range: ±2 to ±10 VDC at rated speed/ max. input voltage: ±12 V	
		Input impedance	Approx. 14 kΩ	
		Circuit time constant	Approx. 47 μs	
		Torque reference input	Reference voltage	±3 VDC (forward rotation if positive reference) at rated speed: set at delivery Variable setting range ±1 to ±10 VDC at rated torque reference
Input impedance	Approx. 14 KΩ			
Circuit time constant	Approx. 47 μs			

Position control mode	Bias setting		0 to 450 min <sup>-1</sup> (setting resolution: 1 min <sup>-1</sup> )
	Feed forward compensation		0 to 100% (setting resolution: 1%)
	Position completed width setting		0 to 250 command units (setting resolution: 1 command unit)
Input signal	Command pulse	Input pulse type	Sign + pulse train, 90° phase displacement 2-phase pulse (A-phase+ B-phase) or CCW/CW pulse train
		Input pulse form	Line driver (+5 V level) , open collector (+5 V or +12 level)
	Control signal	Input pulse frequency	0 to 500 Kpps (200 Kpps max. at open collector)
		Clear signal (input pulse is same as reference pulse)	
I/O signal	Position signal output		A-phase, B.phase, C-phase, (S-phase): line driver output S-phase is for absolute encoder only.
	Sequence input signal		Servo ON, P control (or control mode switching, zero clamp, command pulse inhibit), forward/reverse run prohibit, alarm reset, forward/reverse current limit (or internal speed switching)
	Sequence output signal		Servo alarm, alarm codes (3-bit output): CN1 output terminal is fixed It is possible to output three types of signal form incl.: positioning complete (speed agree), motor rotation, servo ready, current limit, speed limit, brake release, warning, NEAR, and zero point pulse signal
Integrated functions	Communications	Interface	Digital operator (hand- held type), RS-422 port for PCs, etc. (RS-232C ports under some conditions)
		1:N communications	N may equal up to 14 when an RS-422A port is used
		Axis address setting	Set by user setting
		Functions	Status display, user constant setting monitor display, alarm traceback display, JOG run/autotuning operations, and graphing functions for speed/torque command signal, etc
	Automatic load inertia detection		Automatic motor parameter setting. One parameter rigidity setting.
Dynamic brake (DB)		Operates during main power OFF, servo alarm, servo OFF or overtravel	
Regenerative processing		Internal resistor included in models from 500 W to 5 kW. Regenerative resistor externally mounted (option).	
Overtravel (OT) prevention function		DB stop, deceleration stop or coast to stop during P-OT, N-OT operation	
Encoder divider function		Optional division possible	
Electronic gearing		0,01< A/B<100	
Internal speed setting function		3 speeds may be set internally	
Protective functions		Overcurrent, overvoltage, insufficient voltage, overload, main circuit sensor error, heatsink overheat, power phase loss, overflow, overspeed, encoder error, runaway, CPU error, parameter error, etc.	
Analog monitor functions for supervision		Integrates analog monitor connectors for supervision of the speed and torque reference signals, etc.	
Display functions		CHARGE, POWER, 7-segments LEDx5 (integrated digital operator function)	
Others		Reverse connection, zero search, automatic motor discrimination function, and DC reactor connection terminal for high frequency power suppression function (except: 6 to 15 kW)	

I/O specifications

I/O signals (CN1) - input signals

Pin No.	Signal name	Function					
40	Common	/S-ON Servo ON: Turns ON the servo motor when the gate block in the inverter is released.					
41	Common	/P-CON Function selected by parameter.					
		Proportional control reference	Switches the speed control loop from PI (proportional/integral) to P (proportional) control when ON.				
		Direction reference	With the internal set speed selected: switch the rotation direction.				
		Control mode switching	<table border="0"> <tr> <td>Position ↔ speed</td> <td rowspan="3">} Enables control mode switching</td> </tr> <tr> <td>Position ↔ torque</td> </tr> <tr> <td>Torque ↔ speed</td> </tr> </table>	Position ↔ speed	} Enables control mode switching	Position ↔ torque	Torque ↔ speed
		Position ↔ speed	} Enables control mode switching				
Position ↔ torque							
Torque ↔ speed							
Zero-clamp reference	Speed control with zero-clamp function: reference speed is zero when ON.						
Reference pulse block	Position control with reference pulse stop: stops reference pulse input when ON.						
42	P-OT	Forward run prohibited					
43	N-OT	Reverse run prohibited					
45	Common	/P-CL Function selected by parameter.					
46		/N-CL	Forward external torque limit ON				
			Reverse external torque limit ON				
		Internal speed switching	With the internal set speed selected: switches the internal speed settings.				
44	/ALM-RST	Alarm reset: releases the servo alarm state.					
47	+24VIN	Control power supply input for sequence signals: users must provide the +24 V power supply. Allowable voltage fluctuation range: 11 to 25 V					
4 (2)	SEN	Initial data request signal when using an absolute encoder.					
21	BAT (+)	Connecting pin for the absolute encoder backup battery.					
22	BAT (-)	Do not connect when a battery is connected to the host controller.					
5 (6)	Speed	V-REF Speed reference input: ±2 to ±10 V/rated motor speed (input gain can be modified using a parameter.)					
9 (10)	Torque	T-REF Torque reference input: ±1 to ±10 V/rated motor torque (input gain can be modified using a parameter.)					
7	Position	PULS Reference pulse input					
8		/PULS	Input mode is set from the following pulses.				
11		SIGN	Sign + pulse string				
12		/SIGN	CCW/CW pulse				
15	Position	CLR	Two-phase pulse (90° phase differential)				
14		/CLR					
3	Position	PL1	Positional error pulse clear input: clears the positional error pulse during position control.				
13		PL2					
18		PL3					
			+12 V pull-up power is supplied when PULS, SIGN, and CLR reference signals are open-collector outputs (+12 V power supply is built into the SERVOPACK).				

- Note:**
1. Pin numbers in parentheses ( ) indicate signal grounds.
  2. The functions allocated to /S-ON, /P-CON, P-OT, N-OT, /ALM-RST, /P-CL, and /N-CL input signals can be changed by using the parameters.
  3. The voltage input range for speed and torque references is a maximum of ±12 V.

I/O signals (CN1) - output signals

Pin No.	Signal Name	Function		
31 32	Common	ALM+ ALM-	Servo alarm: Turns OFF when an error is detected.	
27 28		/TGON+ /TGON-	Detection during servo motor rotation: detects when the servo motor is rotating at a speed higher than the motor speed setting. Detection speed can be set by using the parameters.	
29 30		/S-RDY+ /S-RDY-	Servo ready: ON if there is no servo alarm when the control/main circuit power supply is turned ON.	
33 (1) 34		PAO /PAO	Phase-A signal Converted two-phase pulse (phases A and B) encoder output Signal and zero-point pulse (phase C) signal: RS-422 or the equivalent (proper line receiver is SN75175 manufactured by Texas Instruments or the equivalent corresponding to MC3486.)	
35 36		PBO /PBO		Phase-B signal
19 20		PCO /PCO		Phase-C signal
48 49		PSO /PSO	Phase-S signal	With an absolute encoder: outputs serial data corresponding to the number of revolutions (RS-422 or the equivalent)
37 38 39 (1)		ALO1 ALO2 ALO3	Alarm code output: Outputs 3-bit alarm codes. Open-collector: 30 V and 20 mA rating maximum	
Shell		FG	Connected to frame ground if the shield wire of the I/O signal cable is connected to the connector shell.	
25 26		Speed	/V-CMP+ /V-CMP-	Speed coincidence (output in speed control mode): detects whether the motor speed is within the setting range and if it matches the reference speed value.
25 26	Position	/COIN+ /COIN-	Positioning completed (output in position control mode): turns ON when the number of positional error pulses reaches the value set. The setting is the number of positional error pulses set in reference units (input pulse units defined by the electronic gear).	
-	Reserved	/CLT /VLT /BK /WARN /NEAR	Reserved terminals The functions allocated to /TGON, /S-RDY, and /V-CMP (/COIN) can be changed by using the parameters. /CLT, /VLT, /BK, /WARN, and /NEAR signals can also be changed.	
16 17 23 24 50		-	Terminals not used Do not connect relays to these terminals.	

**Note:** 1. Pin numbers in parentheses ( ) indicate signal grounds.

2. The functions allocated to /TGON, /S-RDY, and /V-CMP (/COIN) can be changed by using the parameters. /CLT, /VLT, /BK, /WARN, and /NEAR signals can also be changed.

Terminal specifications (all drives)

Symbol	Name	Function		
L1, L2 or L1, L2, L3 or L1/R, L2/S, L3/T	Main circuit AC input terminal	AC power input terminals for the main circuit		
U V W	Servo motor connection terminal	Red White Blue	Terminals for outputs to the servo motor.	
L1C, L2C		Control power input terminal		AC power input terminals for the control circuit.
⊕		Frame ground		Ground terminal. Ground to a maximum of 100 Ω. (class 3)
B1, B2 or B1, B2, B3	Main circuit DC output terminal	Up to 5 kW: Connect an external regenerative resistor if regenerative energy is high. From 5.5 kW to 55 kW: There is no internal regenerative resistor. Be sure to connect an external regenerative resistor unit.		
⊕1, ⊕2	DC reactor connection terminal for suppressing power supply harmonic waves	Normally, short ⊕1 and ⊕2. If a countermeasure against power supply harmonic waves is needed, connect a DC reactor between ⊕1 and ⊕2.		
⊕	Main circuit DC output terminal (positive)	Normally, not connected. This terminal exists on the servo drives with a capacity of 6.0 kW or higher only.		
⊖	Main circuit DC output terminal (negative)	Normally, not connected.		

Terminal specifications (from 22 kW to 55 kW)

Symbol	Name	Function
DC24P, DC24N	Control power supply input terminal	24 VDC
DU, DV, DW	DB resistor unit, DB contactor connection terminal	Connects DB resistor unit or DB contactor.
DBON, DB24	DB resistor unit connection terminal	For 37 to 55 kW, connects to DBON and DB24 terminals or DB resistor unit.
480 V, 460 V, 440 V, 400 V, 380 V, 0 V	Control power Supply input Terminal	Connect to the terminal whose voltage is close to the power supply voltage.

Encoder connector (CN2)

Pin No.	Signal Name	Function
1	E5V	Encoder power supply + 5 V
2	E0V	Encoder power supply ground
3	BAT+	Battery + (used only with absolute encoder)
4	BAT-	Battery - (used only with absolute encoder)
5	S+	Encoder serial signal input
6	S-	Encoder serial signal input

Operation

Operating functions

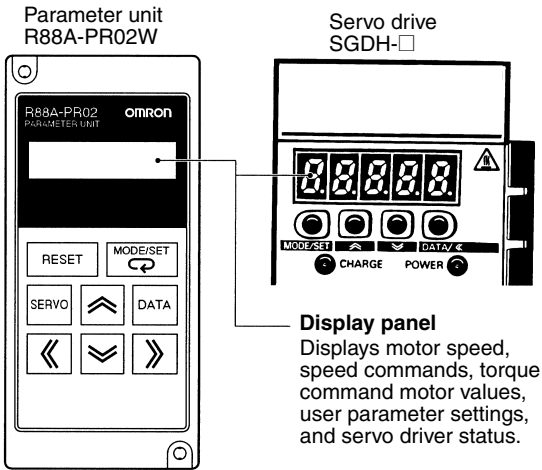

Changing modes

To change modes, press the MODE/SET key.

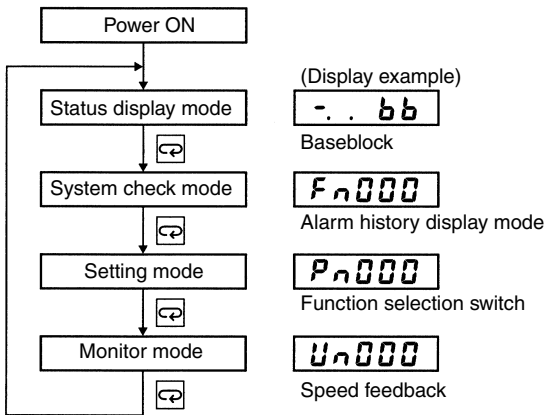

Status display mode

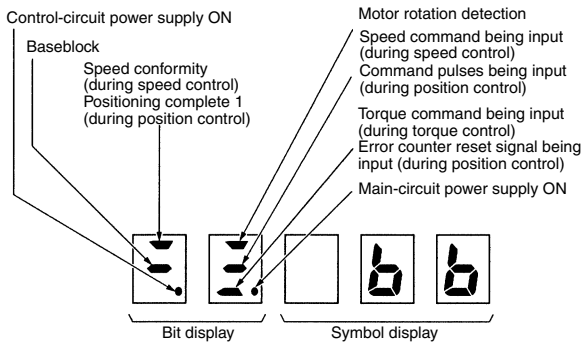

Symbol	Status
bb	Baseblock (motor OFF)
run	Operating
For	Forward rotation prohibited (forward overtravel)
Rev	Reverse rotation prohibited (reverse overtravel)
RD	Alarm display

Unit keys

R88A-PR02W	SGDH-□	Function
RESET	MODE/SET + MODE/SET	Resets an alarm.
MODE/SET	MODE/SET	Switches between status display mode, system check mode, setting mode, and monitor mode. Used as a data setting key while in setting mode.
SERVO	MODE/SET	Turns the servo ON or OFF while jog operations are being performed.
DATA	DATA/◀	Switches between parameter display and data display, and records data.
▲	▲	Increments parameter settings. Used as a forward rotation start key during jog operation.
▼	▼	Decrements parameter settings. Used as a reverse rotation start key during jog operation.
◀	◀	Selects the digit whose setting is to be changed. When selected, the digit flashes.
▶	▶	

Mode details

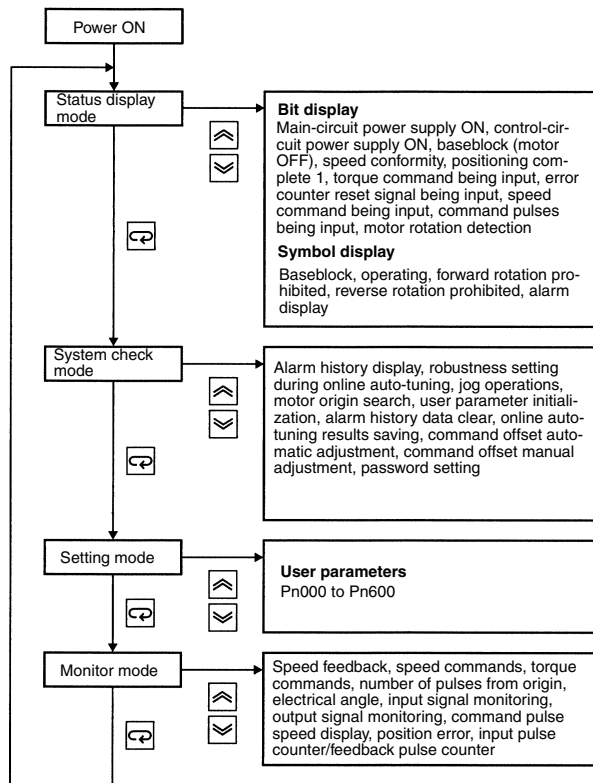

Dimensions

Servo drives

SGDH-A3AE-OY to -02AE-OY (230 V, 30 to 200 W)

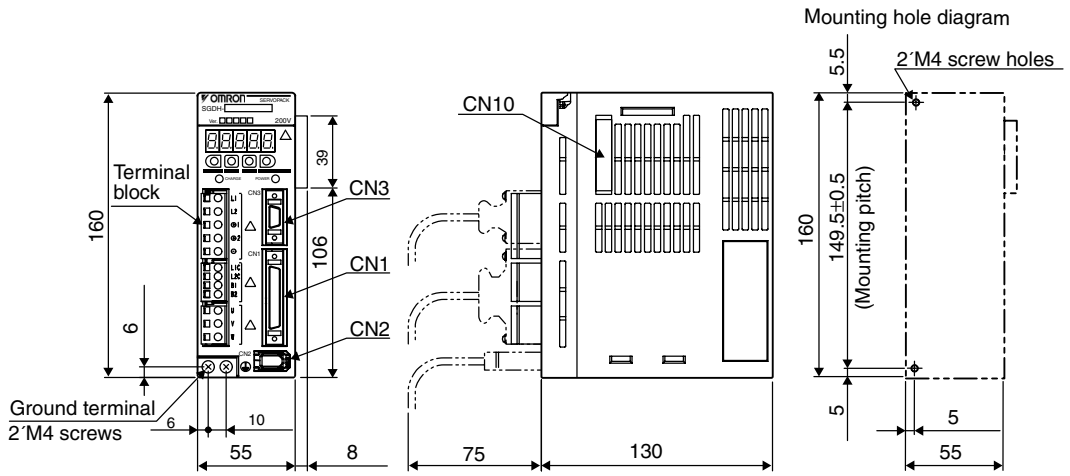

SGDH-04AE-OY (230 V, 400 W)

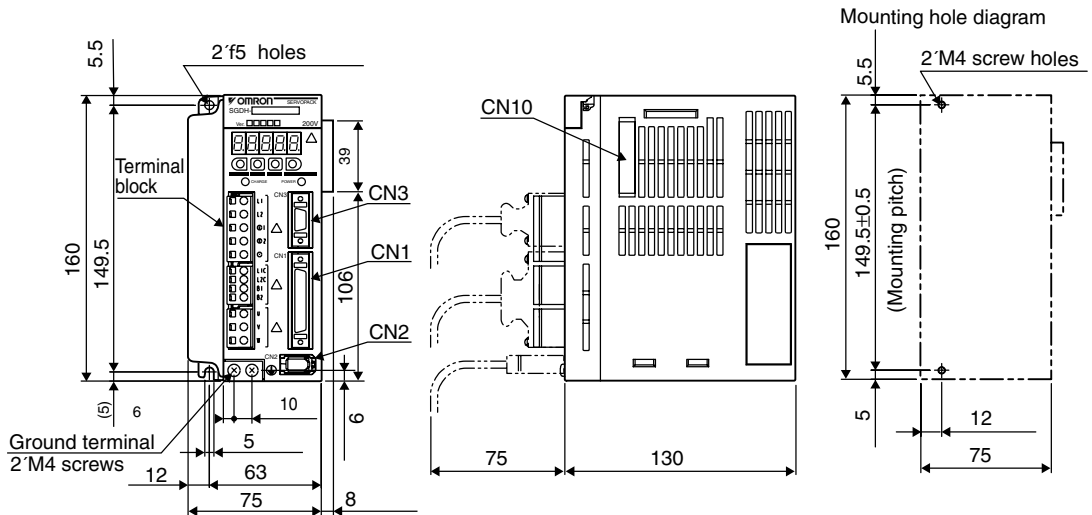

SGDH-08AE-S-OY (230 V, 750 W)

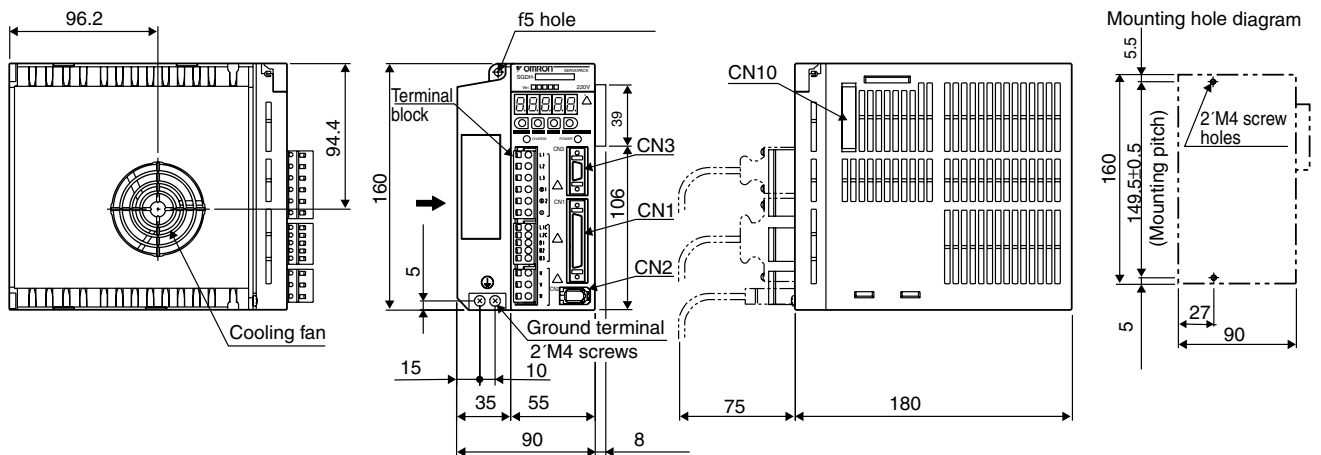



SGDH-05DE-OY to -15DE-OY (400 V, 0.5 to 1.5 kW)

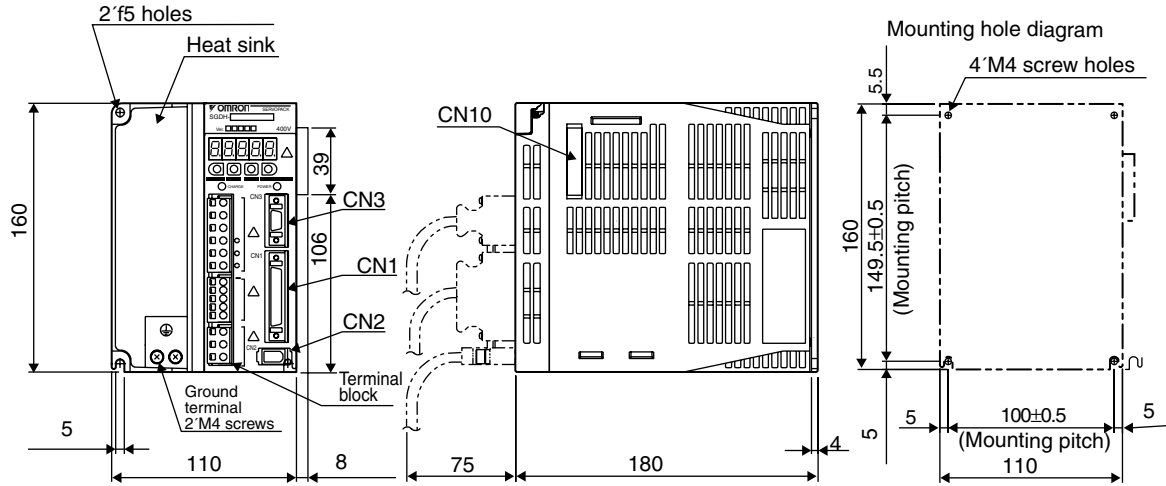

SGDH-15AE-S (230 V, 1.5 kW)

SGDH-20/30DE-OY (400 V, 2/3 kW)

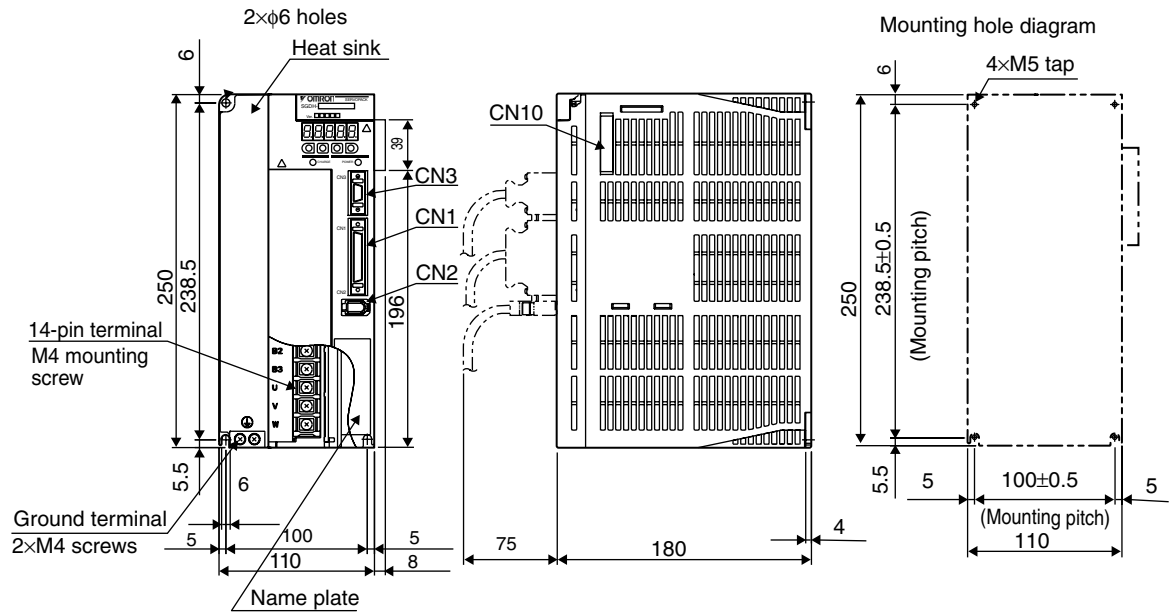



SGDH-50DE-OY (400 V, 5 kW)

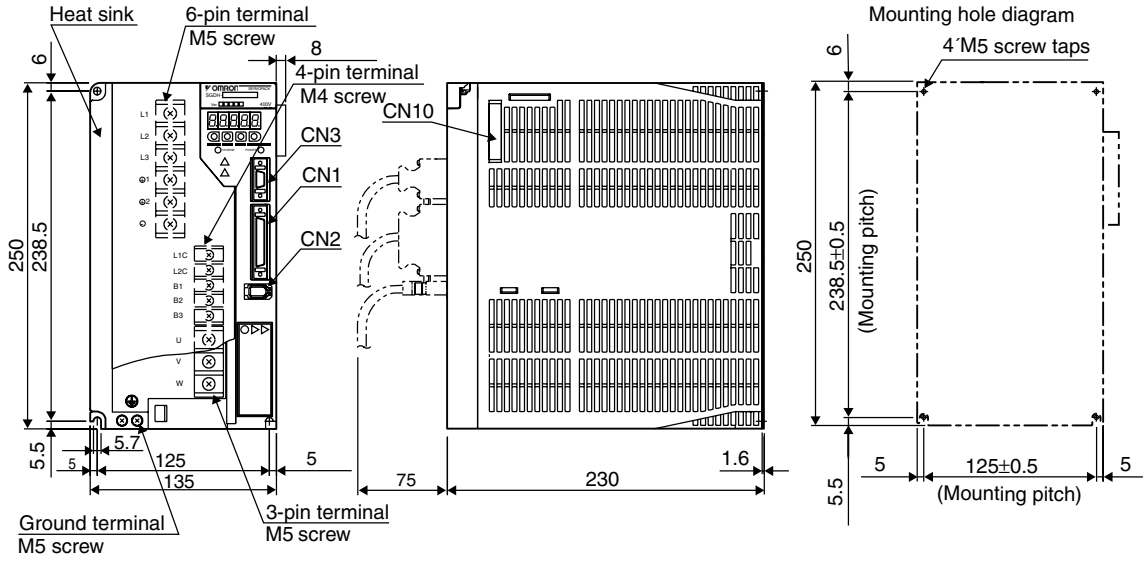

SGDH-60/75DE-OY (400 V, 6/7.5 kW)

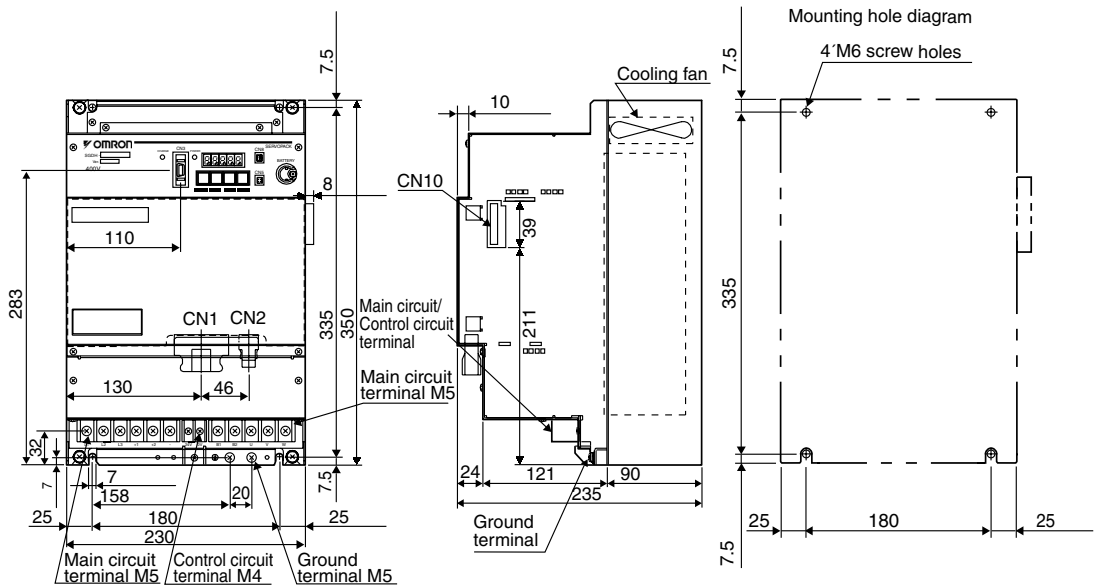

SGDH-1A/1EDE-OY (400 V, 11/15 kW)

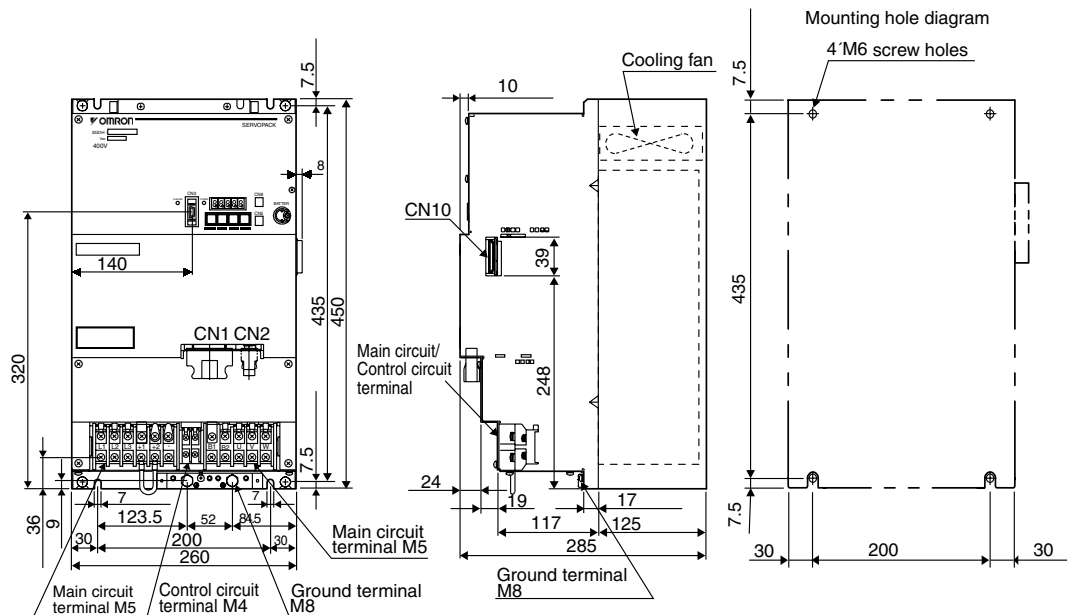

SGDH-2BDE (400 V, 22 kW)

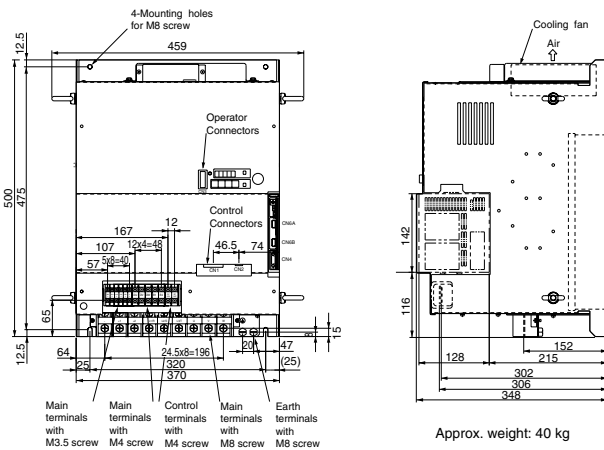

SGDH-3ZDE (400 V, 30 kW)

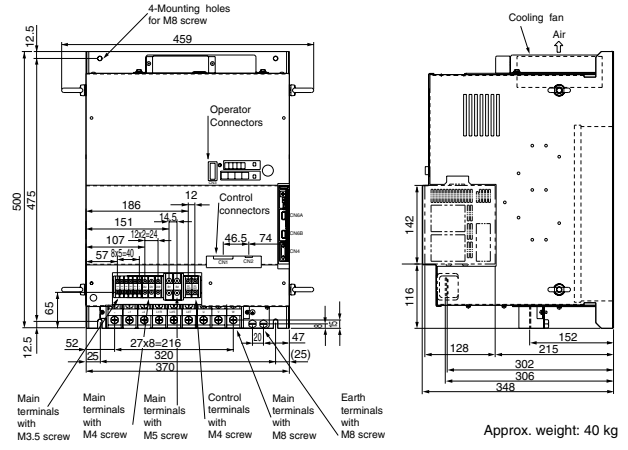

SGDH-3GDE (400 V, 37 kW)

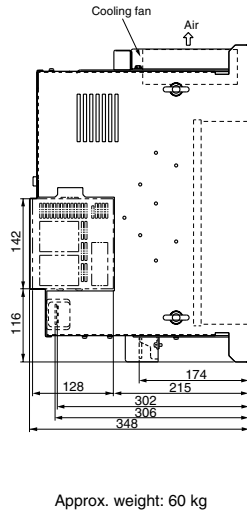
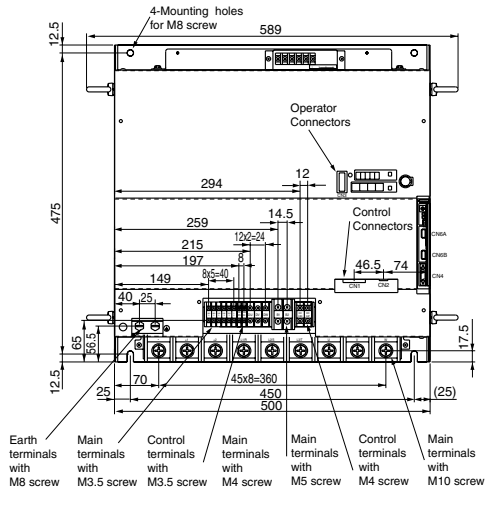

SGDH-4EDE / -5EDE (400 V, 45/55 kW)

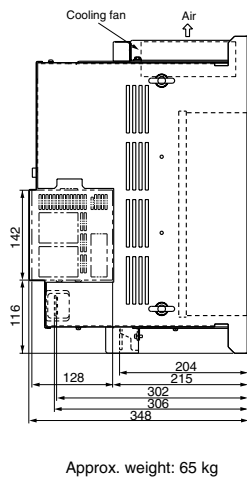
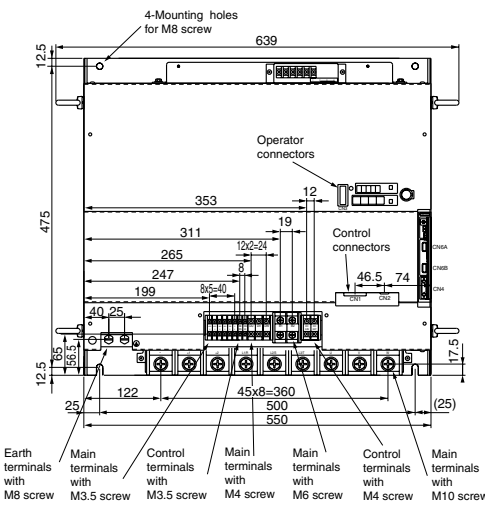

Filters

R88A-FIW104-SE

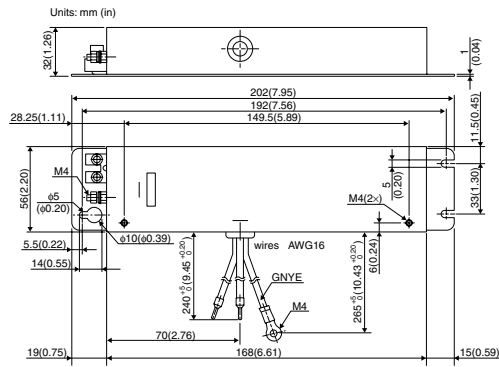

R88A-FIW107-SE, R88A-FIW115-SE

Model	R88A-FIW107-SE	R88A-FIW115-SE
Dimensions in mm	A 75	90
	B 240 <sup>+5</sup>	300 <sup>+5</sup>
	C 50	60
	D 12	15
	E 1	1.2

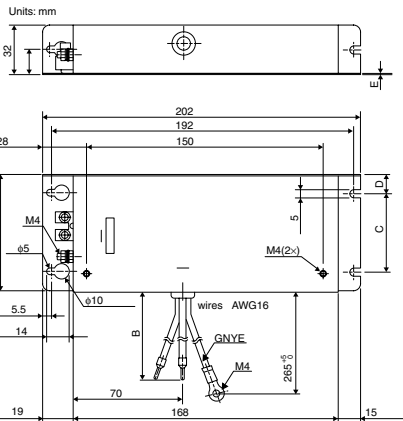

R88A-FIW125-SE

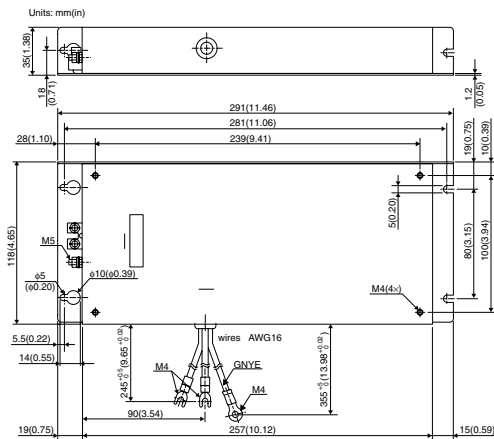

R88A-FIW4006-SE, R88A-FIW4010-SE

Model	R88A-FIW4006-SE	R88A-FIW4010-SE
Dimensions in mm (in)	A 32 (1.26)	35 (1.38)
	B 16 (0.63)	18 (0.71)
	C 202 (7.95)	291 (11.46)
	D 192 (7.56)	281 (11.06)
	E 150 (5.91)	239 (9.41)
	F 300 (11.81)	270 (10.63)
	G 70 (2.76)	90 (3.54)
	H 168 (6.61)	257 (10.12)

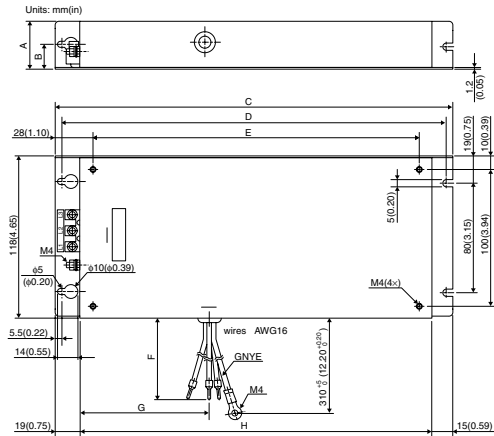

R88A-FIW4020-SE

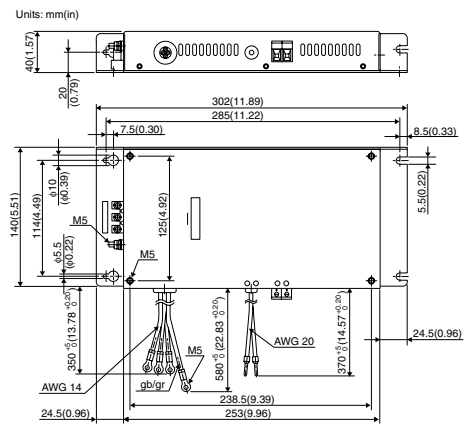

R88A-FIW4030-SE

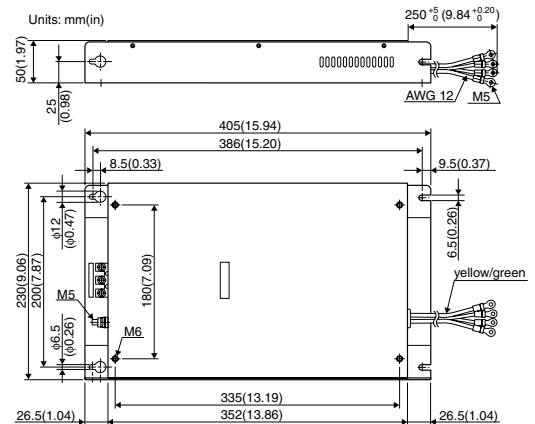

## Filters

### R88A-FIW4055-SE

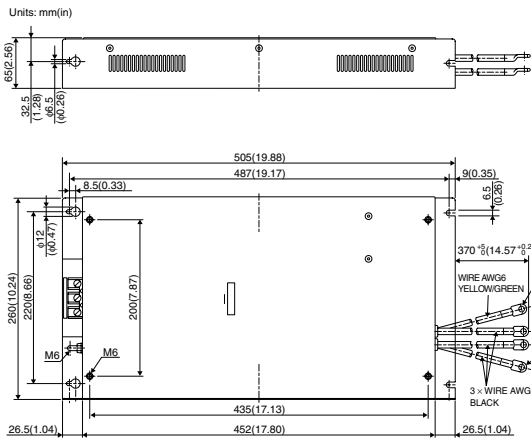

### FN359-250-99

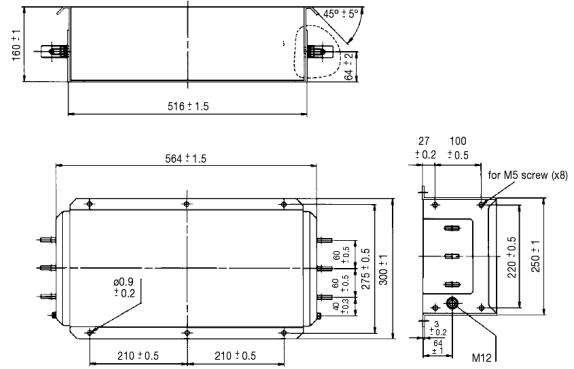

### FN258-180-07

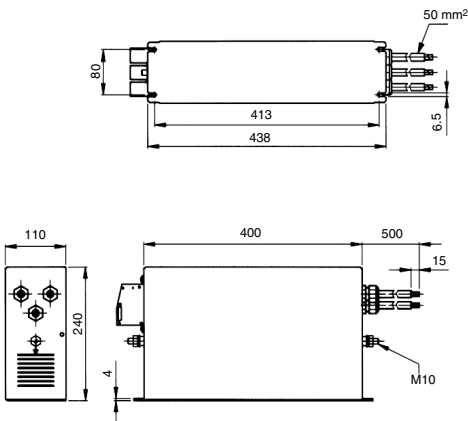

## Digital operator

### JUSP-OP02A-2

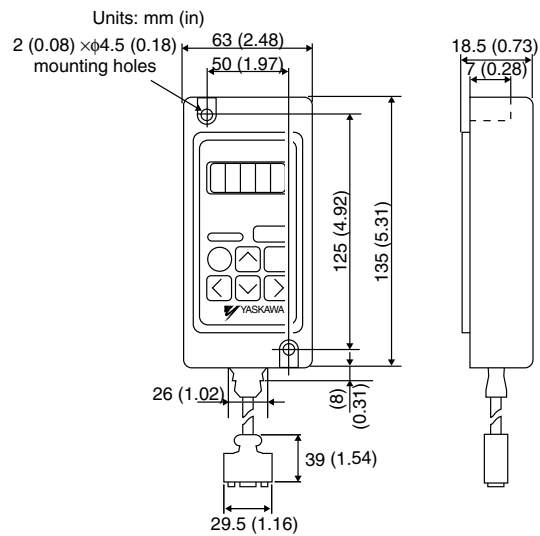

## Regenerative resistor units

Model	W	H	D	M1	M2	Approx. weight kg
JUSP-RA18	220	350	92	180	335	4
JUSP-RA19	300	350	95	250	335	7
JUSP-RA12	259	500	348	200	485	14
JUSP-RA13	259	500	348	200	485	14
JUSP-RA14	484	500	348	425	485	20
JUSP-RA15	484	500	348	425	485	21.5
JUSP-RA16	484	500	348	425	485	23.5

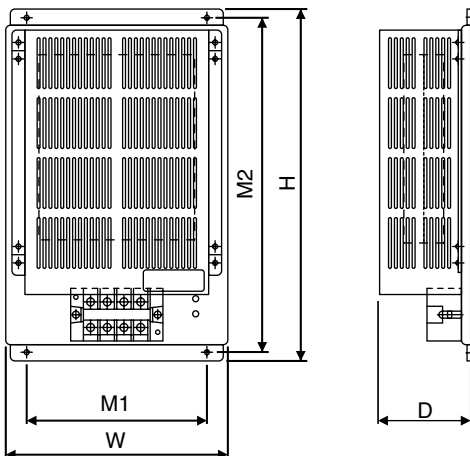

## DB resistor units

Model	H	M2	Approx. weight kg
JUSP-DB03	400	385	5
JUSP-DB04	400	385	6
JUSP-DB05	400	385	6
JUSP-DB06	490	475	7

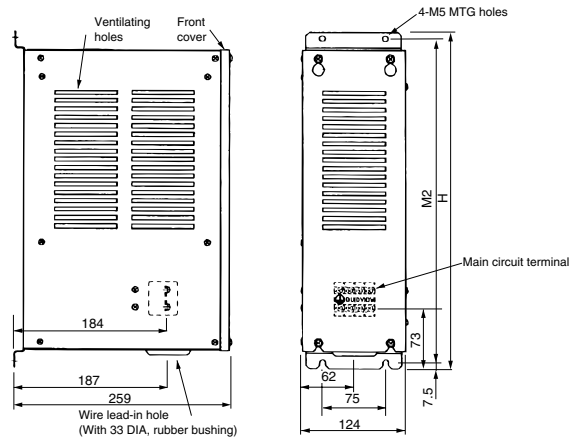

Installation

Single-phase, 230 VAC

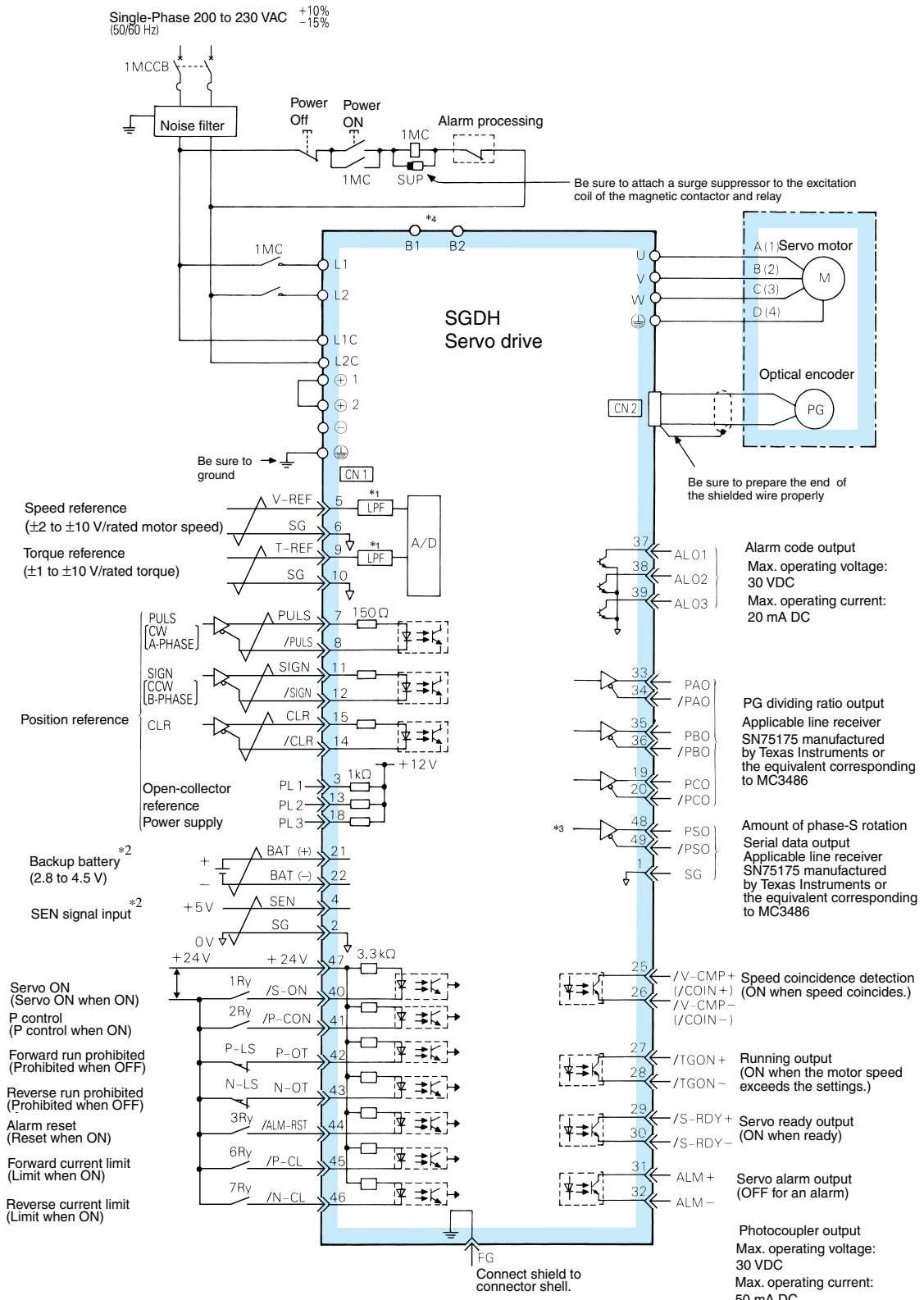

\*1 The time constant for the primary filter is 47 μs.  
 \*2 Connect when using an absolute encoder.  
 \*3 Used only with an absolute encoder.  
 \*4 Regenerative resistor can be connected between B1 and B2.  
 \*5 For types SGDH-08AE-S-OY and SGDH-15AE-S-OY, voltage is 220 to 230 VAC (+10% -15%).  
 \*6 TI stands for Texas Instruments Inc.

Three-phase, 400 VAC (up to 15 kW)

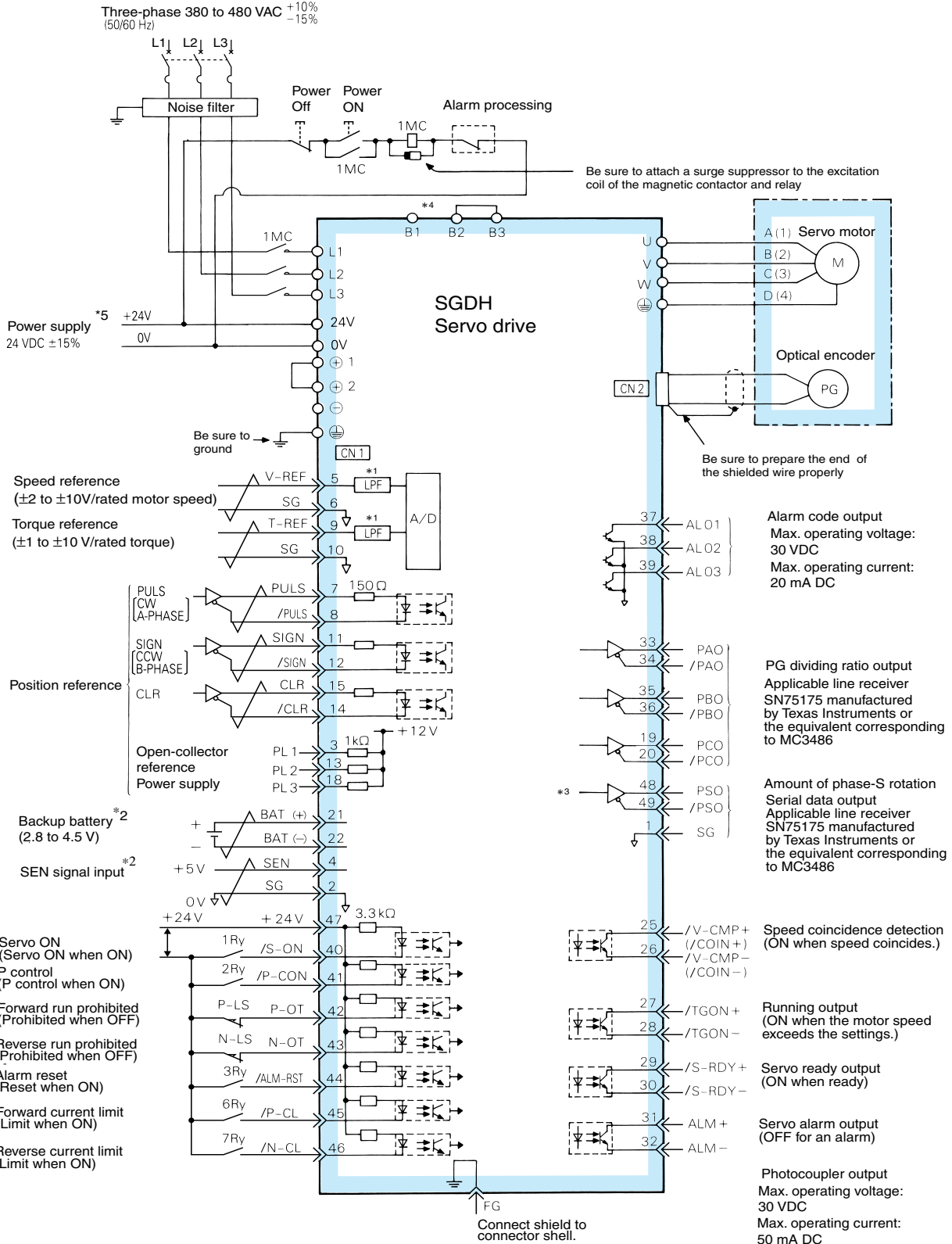

\*1 The time constant for the primary filter is 47  $\mu$ s.

\*2 Connect when using an absolute encoder.

\*3 Used only with an absolute encoder.

\*4 For using an external regenerative resistor, connect it between B1 and B2.  
(Be sure to connect a regenerative resistor unit to Servo Drive of 6/7.5/11/15 kW)

\*5 It is the user's responsibility to obtain 24 VDC power supply.

\*6 TI stands for Texas Instruments Inc.

Three-phase, 400 VAC (from 22 kW to 55 kW)

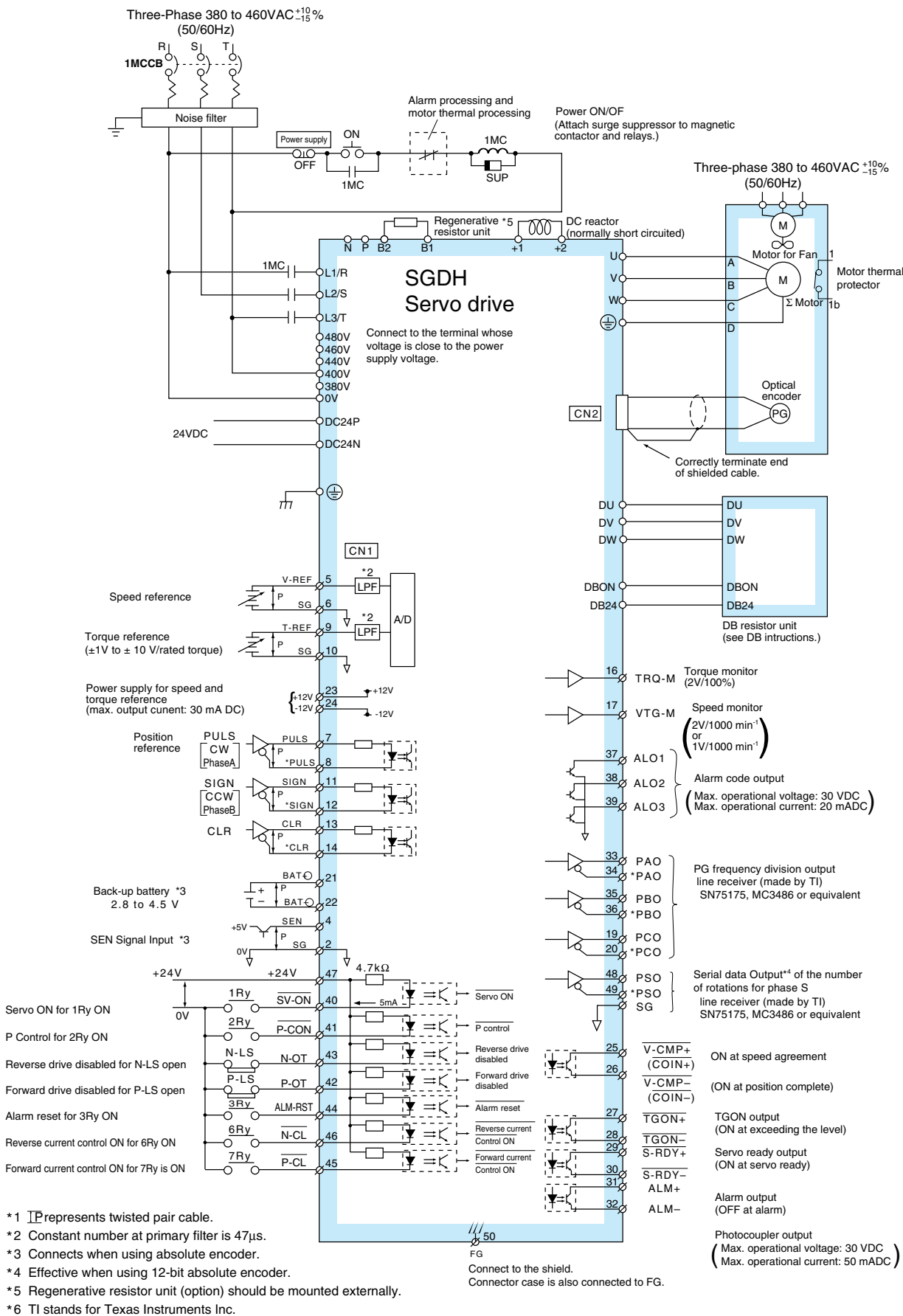



Ordering information

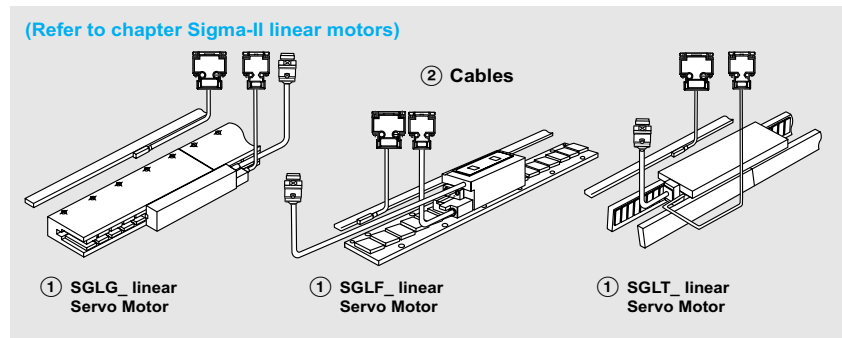
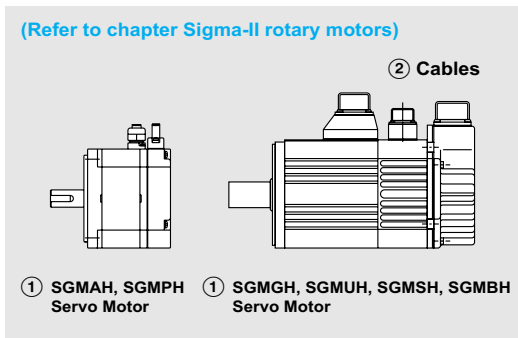
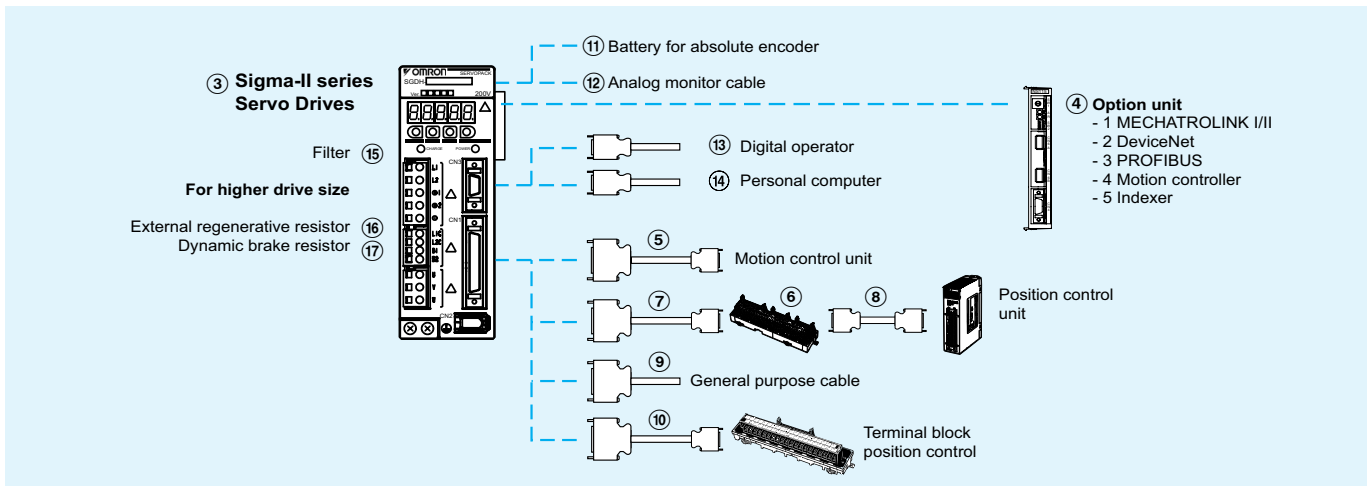

Note: The symbols ①②③④⑤... show the recommended sequence to select the components in a Sigma-II servo system

Servo motors, power & encoder cables

Note: ①② Refer to the servo motors chapter for detailed motor specifications and selection

Servo drives

Symbol	Specifications	Model	Compatible rotary servo motors ①	Compatible linear motors ①	
③	1 phase 200 VAC	30 W	SGDH-A3AE-OY	SGMAH-A3A□	
		50 W	SGDH-A5AE-OY	SGMAH-A5D□	
		100 W	SGDH-01AE-OY	SGMAH-01A□, SGMPH-01A□	SGLGW-30A050□
		200 W	SGDH-02AE-OY	SGMAH-02A□, SGMPH-02A□	SGLGW-30A080□, SGLGW-40A140□
		400 W	SGDH-04AE-OY	SGMAH-04A□, SGMPH-04A□	SGLFW-20A□, SGLFW-35A120□, SGLGW-40A253A□, SGLGW-60A140□
		750 W	SGDH-08AE-S-OY	SGMAH-08A□, SGMPH-08A□	SGLGW-40A365A□, SGLGW-60A253A□
		1500 W	SGDH-15AE-S-OY	SGMPH-15A□	SGLFW-35A230□, SGLFW-50A200□, SGLGW-60A365A□
		3 phase 400 VAC	0.5 kW	SGDH-05DE-OY	SGMGH-05D□, SGMAH-03D□, SGMPH-02D□/04D□
	1.0 kW	SGDH-10DE-OY	SGMGH-09D□, SGM SH/UH-10D□, SGMAH-07D□, SGMPH-08D□	SGLFW-50D200□, SGLTW-35D170□, SGLTW-50D170□	
	1.5 kW	SGDH-15DE-OY	SGMGH-13D□, SGM SH/UH-15D□, SGMPH-15D□	SGLFW-50D380□, SGLFW-1ZD200□	
	2 kW	SGDH-20DE-OY	SGMGH-20D□, SGM SH-20D□	SGLFW-1ED380□, SGLTW-35D320□, SGLTW-50D320□	
	3 kW	SGDH-30DE-OY	SGMGH-30D□, SGM SH/UH-30D□	SGLFW-1ZD380□, SGLFW-1ED560□, SGLTW-40D400□	
	5 kW	SGDH-50DE-OY	SGMGH-44D□, SGM SH/UH-40D□, SGM SH-50D□	SGLTW-40D60□, SGLTW-80D400□	
	6 kW	SGDH-60DE-OY	SGMGH-55D□	-	
	7.5 kW	SGDH-75DE-OY	SGMGH-75D□	SGLTW-80D600□	
	11 kW	SGDH-1ADE-OY	SGMGH-1AD□	-	
	15 kW	SGDH-1EDE-OY	SGMGH-1ED□	-	
	22 kW	SGDH-2BDE	SGMBH-2BD□	-	
	30 kW	SGDH-3ZDE	SGMBH-3ZD□	-	
	37 kW	SGDH-3GDE	SGMBH-3GD□	-	
	45 kW	SGDH-4EDE	SGMBH-4ED□	-	
55 kW	SGDH-5EDE	SGMBH-5ED□	-		

**Option units (for CN10)**

Symbol	Name	Model
④	1.5 axis advanced motion controller with host link interface	R88A-MCW151-E
	1.5 axis advanced motion controller with DeviceNet interface	R88A-MCW151-DRT-E
	MECHATROLINK-I interface unit	JUSP-NS100
	MECHATROLINK-II interface unit	JUSP-NS115
	DeviceNet interface unit with positioning functionality	JUSP-NS300
	PROFIBUS-DP interface unit with positioning functionality	JUSP-NS500
	Indexer unit. Versatile point-to-point positioning	JUSP-NS600

**Note:** ④ Refer to the servo drive option unit chapter for detailed specifications and selection

**Control cables (for CN1)**

Symbol	Description	Connect to		Model
⑤	Control cable (1 axis)	Motion control units CS1W-MC221 CS1W-MC421 C200H-MC221	1 m	R88A-CPW001M1
			2 m	R88A-CPW002M1
			3 m	R88A-CPW003M1
			5 m	R88A-CPW005M1
	Control cable (2 axis)	Motion control units CS1W-MC221 CS1W-MC421 C200H-MC221	1 m	R88A-CPW001M2
			2 m	R88A-CPW002M2
			3 m	R88A-CPW003M2
			5 m	R88A-CPW005M2
	Terminal block (4 axes)	Motion control unit C200HW-MC402-E	-	R88A-TC04-E
	Servo drive connecting cable (1 axis)		1 m	R88A-CMUK001J3-E2
PLC unit control cables (4 axes)	1 m		R88A-CMX001S-E	
	1 m	R88A-CMX001J1-E		
⑥	Servo relay unit	CS1W-NC1□3, CJ1W-NC1□3, or C200HW-NC113 Position control unit		XW2B-20J6-1B (1 axis)
				XW2B-40J6-2B (2 axes)
		CS1W-NC2□3/4□3, CJ1W-NC2□3/4□3, or C200HW-NC213/413 position control unit		XW2B-20J6-3B (1 axis)
				XW2B-20J6-8A (1 axis)
				XW2B-40J6-9A (2 axes)
⑦	Cable to servo drive	Servo relay units XW2B-□0J6-□B	1 m	XW2Z-100J-B4
			2 m	XW2Z-200J-B4
⑧	Position control unit connecting cable	C200H-NC112	0.5 m	XW2Z-050J-A1
			1 m	XW2Z-100J-A1
		C200H-NC211	0.5 m	XW2Z-050J-A2
			1 m	XW2Z-100J-A2
		CQM1-CPU43-V1 and CQM1H-PLB21	0.5 m	XW2Z-050J-A3
			1 m	XW2Z-100J-A3
		CS1W-NC113 and C200HW-NC113	0.5 m	XW2Z-050J-A6
			1 m	XW2Z-100J-A6
		CS1W-NC213/413 and C200HW-NC213/413	0.5 m	XW2Z-050J-A7
			1 m	XW2Z-100J-A7
		CS1W-NC133	0.5 m	XW2Z-050J-A10
			1 m	XW2Z-100J-A10
		CS1W-NC233/433	0.5 m	XW2Z-050J-A11
			1 m	XW2Z-100J-A11
		CJ1W-NC113	0.5 m	XW2Z-050J-A14
			1 m	XW2Z-100J-A14
		CJ1W-NC213/413	0.5 m	XW2Z-050J-A15
			1 m	XW2Z-100J-A15
CJ1W-NC133	0.5 m	XW2Z-050J-A18		
	1 m	XW2Z-100J-A18		
CJ1W-NC233/433	0.5 m	XW2Z-050J-A19		
	1 m	XW2Z-100J-A19		
CJ1M-CPU22/23	0.5 m	XW2Z-050J-A27		
	1 m	XW2Z-100J-A27		
⑨	Control cable	For general purpose controllers	1 m	R88A-CPW001S or JZSP-CKI01-1
			2 m	R88A-CPW002S or JZSP-CKI01-1
⑩	Relay terminal block cable	General purpose controller	1 m	R88A-CTW001N
			2 m	R88A-CTW002N
	Relay terminal block		-	XW2B-50G5

## Battery backup for absolute encoder (for CN8)

Symbol	Name	Model
⑪	Battery for 30 W to 5 kW drives	JZSP-BA01
	Battery for 6 kW to 15 kW drives	JZSP-BA01-1

## Cable (for CN5)

Symbol	Name	Model
⑫	Analog monitor cable	R88A-CMW001S or DE9404559

## Filters

Symbol	Applicable servo drive	Filter model	Rated current	Rated voltage
⑮	SGDH-A3AE-OY,SGDH-A5AE-OY, SGDH-01AE-OY,SGDH-02AE-OY	R88A-FIW104-SE	4 A	250 VAC single-phase
	SGDH-04AE-OY	R88A-FIW107-SE	7A	
	SGDH-08AE-S-OY	R88A-FIW115-SE	15 A	
	SGDH-15AE-S-OY	R88A-FIW125-SE	25 A	
	400 VAC three-phase	SGDH-05DE-OY,SGDH-10DE-OY, SGDH-15DE-OY	R88A-FIW4006-SE	6 A
		SGDH-20DE-OY,SGDH-30DE-OY	R88A-FIW4010-SE	10 A
		SGDH-50DE-OY	R88A-FIW4020-SE	20 A
		SGDH-60DE-OY,SGDH-75DE-OY	R88A-FIW4030-SE	30 A
		SGDH-1ADE-OY,SGDH-1EDE-OY	R88A-FIW4055-SE	55 A
		SGDH-2BDE,SGDH-3ZDE,SGDH-3GDE	FN258-180-07	180 A
		SGDH-4EDE,SGDH-5EDE	FN359-250-99	250 A

## Options (for CN3)

Symbol	Name	Model
⑬	Parameter unit with cable	JUSP-OP02A-2 or R88A-PR02W
		R88A-CCW002P2 or JZSP-CMS02
⑭	Computer connecting cable	R88A-CCW002P2 or JZSP-CMS02

## External regenerative resistor

Symbol	Applicable servo drive	Regenerative resistor unit model	Specifications
⑯	SGDH-60DE-OY to -75DE-OY	JUSP-RA18	18 Ω , 880 W
	SGDH-1ADE-OY to -1EDE-OY	JUSP-RA19	14.25 Ω , 1760 W
	SGDH-2BDE	JUSP-RA12	9 Ω , 3600 W
	SGDH-3ZDE	JUSP-RA13	6.7 Ω , 3600 W
	SGDH-3GDE	JUSP-RA14	5 Ω , 4800 W
	SGDH-4EDE	JUSP-RA15	4 Ω , 6000 W
	SGDH-5EDE	JUSP-RA16	3.8 Ω , 7200 W

## DB resistor units

Symbol	Servo drive model	Regenerative resistor unit model	Specifications. Star wiring
⑰	SGDH-2BDE,SGDH-3ZDE	JUSP-DB03	180 W, 0.8 Ω
	SGDH-3GDE	JUSP-DB04	180 W, 0.8 Ω
	SGDH-4EDE	JUSP-DB05	180 W, 0.8 Ω
	SGDH-5EDE	JUSP-DB06	300 W, 0.8 Ω

## Connectors

Specification	Model
Control I/O connector (for CN1)	R88A-CNU11C or JZSP-CKI9
Sigma-II drive encoder connector (for CN2)	JZSP-CMP9-1
Communications connector (for CN3)	R7A-CNA01R
Hypertac power connector IP67 (for 200 V motors SGMAH/PH-□□A□□□□D-OY)	SPOC-06K-FSDN169
Hypertac power connector IP67 (for 400 V motors SGMAH/PH-□□D□□□□D-OY)	LPRA-06B-FRBN170
Hypertac encoder connector IP67 (for motors SGMAH/PH-□□□□□□□D-OY)	SPOC-17H-FRON169
Military power connector IP67 (for 400 V motors SGMGH-(05/10/13)D□, SGMSh-(10/15/20)D□, SGMUH-(10/15)D□)) (for SGMbH-□ fan)	MS3108E18-10S
Military power connector IP67 (for 400 V motors SGMGH-(20/30/44)D□, SGMSh-(30/40/50)D□, SGMUH-(30/40)D□)	MS3108E22-22S
Military power connector IP67 (for 400 V motors SGMGH-(55/75/1A/1E)D□)	MS3108E32-17S
Military brake connector IP67 (for 400 V servo motors SGMGH-□, SGMSh-□, SGMUH-□)	MS3108E10SL-3S
Military encoder connector IP67 (for motors SGMGH-□, SGMSh-□, SGMUH-□, SGMbH-□)	MS3108E20-29S

## Computer software

Specifications	Model
Configuration and monitoring software tool for servo drives and inverters. (CX-drive version 1.11 or higher)	CX-drive
Complete OMRON software package including CX-drive. (CX-One version 1.1 or higher)	CX-One

ALL DIMENSIONS SHOWN ARE IN MILLIMETERS.  
To convert millimeters into inches, multiply by 0.03937. To convert grams into ounces, multiply by 0.03527.