

CJ1W-NC□8□ - NC EtherCAT

Position control unit

Motion controllers

Multi-axis point-to-point positioning controller over EtherCAT

- Position control units with 2, 4, 8 or 16 axes.
- NC_82 models support up to 64 additional nodes: inverters, vision systems and distributed I/Os.
- Linear and circular interpolation.
- Linear and infinite axes management.
- Programming languages: ladder and function blocks. Certified PLCopen motion control function blocks.
- The unit can perform various operation sequences in the memory operation data.
- CX-Programmer software for unit setup, EtherCAT network configuration and PLC programming.



System configuration

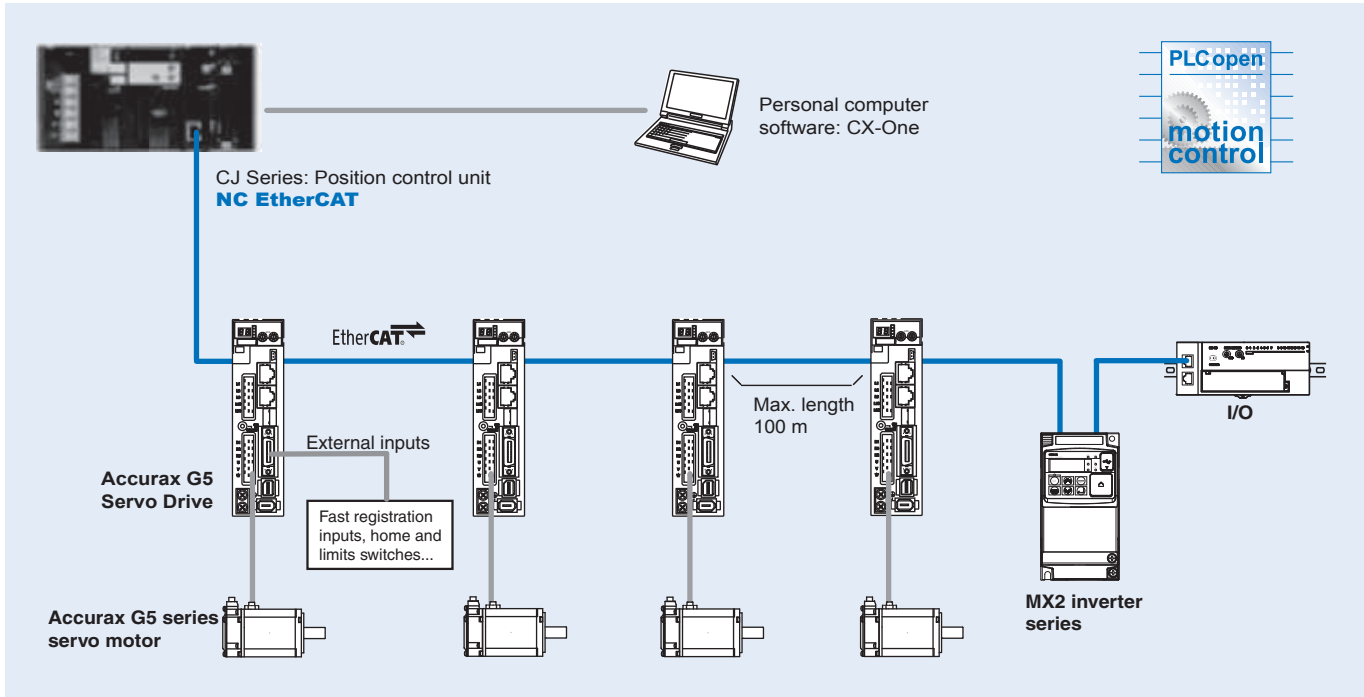

Specifications

Position control unit

Model	CJ1W-NC281	CJ1W-NC481	CJ1W-NC881	CJ1W-NCF81	CJ1W-NC482	CJ1W-NC882	CJ1W-NCF82
Classification	CJ-series CPU bus unit						
Applicable PLCs	CJ-series V. 3.0 or later in order to use function blocks						
Possible unit number settings	0 to F						
number of units per PLC	10 units per Rack, 16 units in total (with expansion racks)						
Control method	EtherCAT commands (CoE)						
Controlled servo drives	Accurax G5 servo drives with EtherCAT built-in						
Controlled axes	2	4	8	16	4 + 64 nodes for remote I/O ^{*1}	8 + 64 nodes for remote I/O ^{*1}	16 + 64 nodes for remote I/O ^{*1}
Virtual axes	-	-	-	-	When a physical axis is disabled, it will operate as virtual axis.		
Node address setting range	1 to 2	1 to 4	1 to 8	1 to 16	1 to 4 and 17 to 80 ^{*2}	1 to 8 and 17 to 80 ^{*2}	1 to 16 and 17 to 80 ^{*2}
I/O allocations	Common operating memory area	Words allocated in CPU bus unit area: 25 words					
	Axis operating memory area	Allocated in one of the following areas (user-specified): CIO, WR, DM, or EM area. Number of words allocated: 43 words for each node (2+12 output words, 13+16 input words)					
	Memory operation memory areas	Allocated in one of the following areas (user-specified): CIO, WR, DM, or EM area Number of words allocated: 7 words for each task (3 output words, 4 input words)					
	I/O memory areas	-	-	-	-	Allocated in one of the following areas (user-specified): CIO, WR, DM, or EM area. Number of words: 1,300 words maximum (640 output words, 640 input words, 20 communication status words).	
Control command range	Position command range	-2,147,483,648 to 2,147,483,647 (command units)					
	Speed command range for position control	1 to 2,147,483,647 (command units/s)					
Control functions	Positioning functions	Memory operation or direct operation					
	Linear interpolation	Up to 2 axes	Up to 4 axes				
	Circular interpolation	Up to 2 axes					
	Origin determination	<ul style="list-style-type: none"> • Origin search: establishes the origin using the specified search method. • Present position preset: changes the present position to a specified position to establish the origin. • Origin return: returns the axis from any position to the established origin. • Absolute encoder origin: establishes the origin using a servo motor that has an absolute encoder. 					
	Jogging	Outputs a fixed speed in the CW or CCW direction.					
	Interrupt feeding	Performs positioning by moving the axis a fixed amount when an external interrupt input is received while the axis is moving.					
	Stop functions	Deceleration stop and emergency stop.					
Auxiliary functions	Acceleration/deceleration curves	Sets either a trapezoidal (linear) curve or an S-curve (moving average).					
	Torque limit	Restricts the torque upper limit during position control.					
	Overrides	Multiplies the axis command speed by a specified ratio during operation. Axis setting: 0.01% to 500%					
	Servo parameter transfer	Reads and writes the servo drive parameters from the ladder program in the CPU unit.					
	Monitoring function	Monitors the control status of the servo drive's command coordinate positions, feedback position, current speed, torque, etc.					
	Software limits	Sets forward and reverse software limits for axis operation. Can be set for each axis.					
	Backlash compensation	Compensates for the amount of play in the mechanical system according to a set value.					
	Deviation counter reset	The position deviation in the servo drive's deviation counter can be reset to 0 (unit version 1.3 or later).					
	Teaching	This function can be used to record the present position into specified position data after moving to the desired position, e.g., by using jogging.					
EtherCAT master port	Drive Profile ^{*3}	CSP mode (CiA402 DriveProfile),			CSP, CSV, CST modes (CiA402 DriveProfile) ^{*4}		
	Communications cycle	250 us, 500 us, 1ms or 2 ms depending on the number of slaves connected and slaves specifications.					
	Communications standard	IEC 61158 Type 12					
	Physical layer	100Base-TX (IEEE802.3)					
	Connector	RJ45 connector x 1					
	Communications media	Category 5 or higher (recommended: cable with double, aluminum tape and braided shielding)					
	Communications distance	Distance between nodes: 100 m max.					
Topology	Daisy chain only.						
Programming methods	Standard ladder	Directly over NC unit memory area					
	Function blocks	Using standard PLCopen motion control function blocks					
	Sequence functions	The unit can perform various operation sequences in the memory operation data without affecting the ladder programming in the CPU. For continuous positioning and speed changes. 4 tasks x 500 steps					
Applicable standards	Conforms to cULus and EC Directives.						
Internal current consumption	460 mA or less at 5 VDC						
Weight	110 g						

Notes: *1 Support for 64 I/O, inverter and vision system device nodes.
*2 Node address 17 to 80 are reserved for remote I/O slaves.
*3 This profile is used when the unit is connected to the Accurax G5 servo drive.
*4 The CSV and CST modes are supported only with NC_82 unit version 1.3 or higher combined with CJ2H-CPU ver. 1.4 or higher.



Nomenclature

CJ1W-NC□8□ - position control unit

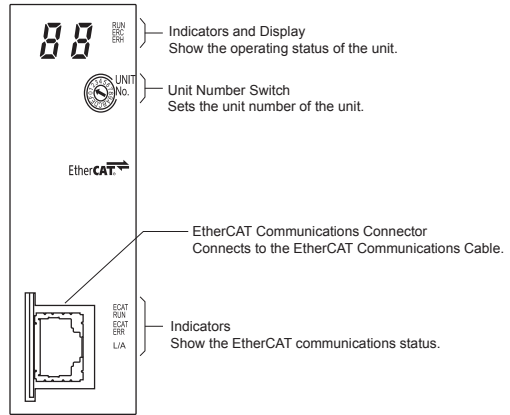
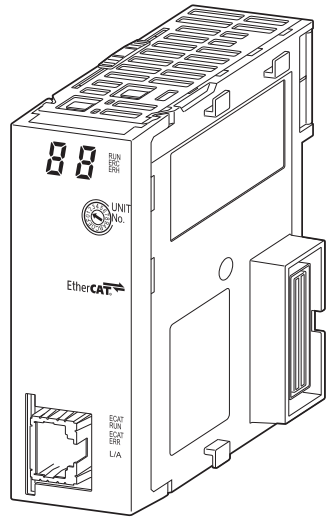

Dimensions

CJ1W-NC□8□ - position control unit

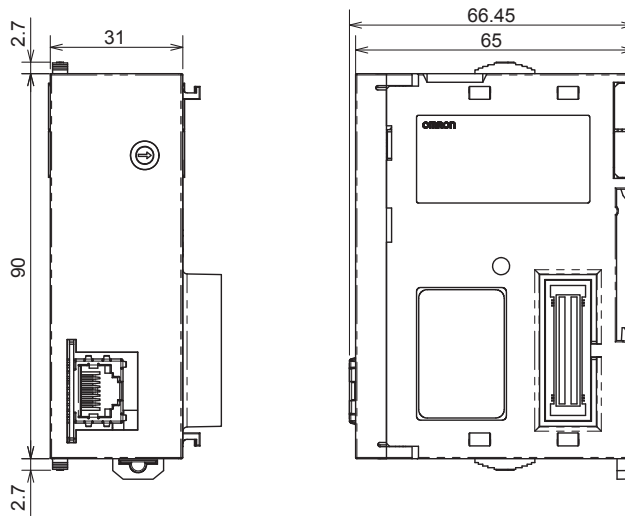

Ordering information

Position controller unit

Name	Model
Position controller unit - EtherCAT - 16 axes + 64 nodes for remote I/O	CJ1W-NCF82
Position controller unit - EtherCAT - 8 axes + 64 nodes for remote I/O	CJ1W-NC882
Position controller unit - EtherCAT - 4 axes + 64 nodes for remote I/O	CJ1W-NC482
Position controller unit - EtherCAT - 16 axes	CJ1W-NCF81
Position controller unit - EtherCAT - 8 axes	CJ1W-NC881
Position controller unit - EtherCAT - 4 axes	CJ1W-NC481
Position controller unit - EtherCAT - 2 axes	CJ1W-NC281

EtherCAT related devices

Servo system & frequency inverter

Name	Model
Accurax G5 servo drive EtherCAT built-in	R88D-KN□□□-ECT
MX2 inverter with EtherCAT option board	Frequency inverter 3G3MX2-A□
	EtherCAT option board 3G3AX-MX2-ECT

Note: Refer to servo system and frequency inverter sections for detailed specs and ordering information.

GX-Series I/O Blocks

Name		Model
16 NPN inputs	24 VDC, 6 mA, 1-wire connection, expandable	GX-ID1611
16 PNP inputs	24 VDC, 6 mA, 1-wire connection, expandable	GX-ID1621
16 NPN outputs	24 VDC, 500 mA, 1-wire connection, expandable	GX-OD1611
16 PNP outputs	24 VDC, 500 mA, 1-wire connection, expandable	GX-OD1621
8 inputs and 8 outputs, NPN	24 VDC, 6 mA input, 500 mA output, 1-wire connection	GX-MD1611
8 inputs and 8 outputs, PNP	24 VDC, 6 mA input, 500 mA output, 1-wire connection	GX-MD1621
16 NPN inputs	24 VDC, 6 mA, 3-wire connection	GX-ID1612
16 PNP inputs	24 VDC, 6 mA, 3-wire connection	GX-ID1622
16 NPN outputs	24 VDC, 500 mA, 3-wire connection	GX-OD1612
16 PNP outputs	24 VDC, 500 mA, 3-wire connection	GX-OD1622
8 inputs and 8 outputs, NPN	24 VDC, 6 mA input, 500 mA output, 3-wire connection	GX-MD1612
8 inputs and 8 outputs, PNP	24 VDC, 6 mA input, 500 mA output, 3-wire connection	GX-MD1622
16 relay outputs	250 VAC, 2 A, 1-wire connection, expandable	GX-OC1601
4 analogue inputs, current/voltage	±10 V, 0-10 V, 0-5 V, 1-5 V, 4-20 mA	GX-AD0471
2 analogue outputs, current/voltage	±10 V, 0-10 V, 0-5 V, 1-5 V, 4-20 mA	GX-DA0271
2 encoder open collector inputs	500 kHz Open collector input	GX-EC0211
2 encoder line-driver inputs	4 MHz Line driver input	GX-EC0241

Note: Refer to Automation systems catalogue for detailed specs and ordering information.

Vision system

Name	Specification	Model
Vision system with EtherCAT interface	NPN	FZM1-350-ECT
	PNP	FZM1-355-ECT

Note: Refer to vision system documentation for detailed specs and ordering information.

Computer software

Specifications	Model
CX-One version 4 or higher	CX-One
CX-Programmer version 9.12 or higher	CX-Programmer

ALL DIMENSIONS SHOWN ARE IN MILLIMETERS.
To convert millimeters into inches, multiply by 0.03937. To convert grams into ounces, multiply by 0.03527.