

# SMARTSLICE

Intelligence, point by point



» Reduce engineering time

» Increase your efficiency

» Reduce machine downtime

## SmartSlice: Intelligence at I/O level

*In automated production, high availability is absolutely critical to stay efficient. Smart control systems that can help your process stay up are always a worthwhile investment. To help increase your efficiency, Omron is continually improving the communications, flexibility and intelligence of its devices while maintaining the scalability, reliability and backwards compatibility that have become distinguishing features of its range of products.*

Omron's SmartSlice is a modular remote I/O system full of patented, smart features – making it the most intelligent and easy-to-use remote I/O system currently available. SmartSlice will allow you to minimise engineering, troubleshooting and maintenance in your machine, line or plant, resulting in significantly reduced downtime.

### **Cost-efficient operation**

Fast installation, easy configuration, reduced wiring, efficient use of cabinet space and built-in diagnostics all combine to make SmartSlice a key element of Omron's cost-efficient control solution. Furthermore, its high degree of modularity means it can be tailored to meet your specific requirements; you install just the right amount of I/O needed for each application.

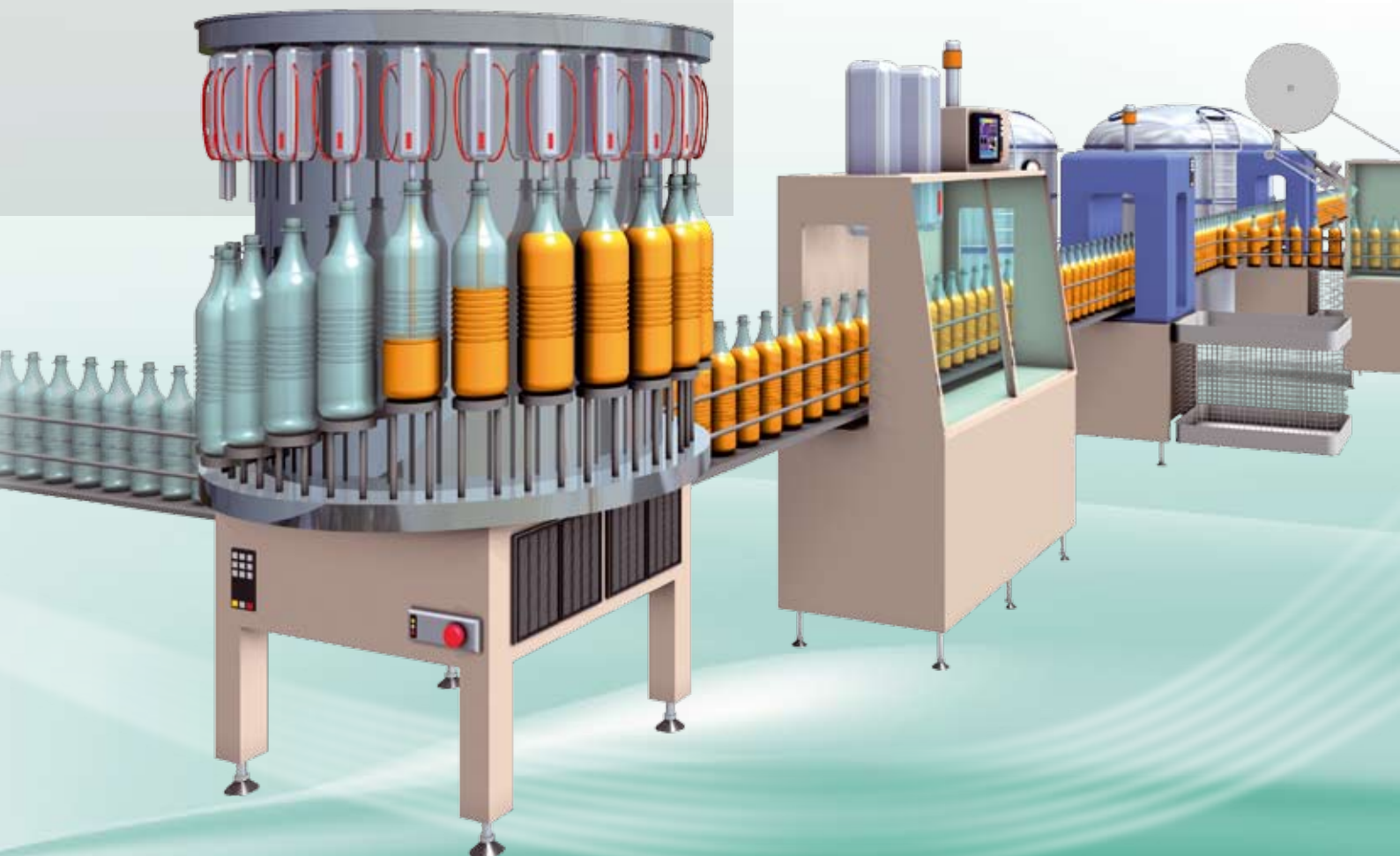

# Smart networking through global standards

SmartSlice connects to any control system via established open communication standards such as DeviceNet and Profibus-DP, and up-to-date technologies like ProfiNet-IO and CompoNet. You can adapt to local preferences, with Omron's global support.

## PROFINET-IO



The benefits of Ethernet communication with the reliability and convenience of proven field networks. Offering real-time capability, yet as easy to configure as conventional bus systems thanks to DTM technology. Built-in switches allow line, star or even ring topology thanks to integrated support for the MRP redundancy protocol.

## PROFIBUS



Choose Profibus-DP for data rates up to 12 Mbit/s, or long-distance communication up to 1200 m per segment. Fast cyclic data exchange can be combined with DPV1 acyclic messaging for parameter setting. Setup is easy thanks to the latest FDT/DTM technology.

## DEVICENET



Choose DeviceNet for plug-and-work operation on Omron PLC systems; no setup is required. DeviceNet also allows you to tune performance to your needs. With a choice of communication methods – cyclic, polled or change-of-state – each slave can communicate in the way best suited for the application.

## CompoNet



Ease of use and versatility are the keywords for this fast CIP-based network for I/O components. Basic set-up is plug-and-play, yet it offers full access to device parameters. Flexibility in network layout caters for a wide range of applications, from high-speed in-machine use, to wide-spread free-topology systems for warehouse applications.



## MECHATROLINK-II

Connect Remote I/Os to Trajexia, Omron's advanced motion controller. This modular motion system can connect to servo drives and inverters using MECHATROLINK II, an open standard for motion control networking.



# Smart functions you can rely on

## Maintenance data logging minimises downtime

All SmartSlice I/O units autonomously collect and store the information that will help you plan machine maintenance. Timely detection of reduced performance will minimise unplanned downtime and keep machine performance fast and reliable.

Each unit remembers its last maintenance date: maintenance personnel can check per unit if there have been any replacements or repairs. A descriptive comment can be entered per node, per unit, even per I/O point. This can help you troubleshoot a machine without having to know PLC-internal tag names or programs. All communication that is required passes through multiple network layers without any special PLC programming to gather or store the data.

## Early-warning system prevents breakdowns

Every SmartSlice unit has its own built-in early-warning functions, enabling you to schedule maintenance and prevent breakdowns. Warnings include:



Supply voltage out of safe range – e.g. due to damaged cable or poor connection.



Preset maintenance interval exceeded – which can be a time interval or a target number of operations, to indicate that an inspection of (electro)mechanical parts is required.



Maximum allowed delay between two I/O signals is exceeded – to indicate that wear or lack of lubrication is causing a machine to work slower than intended.

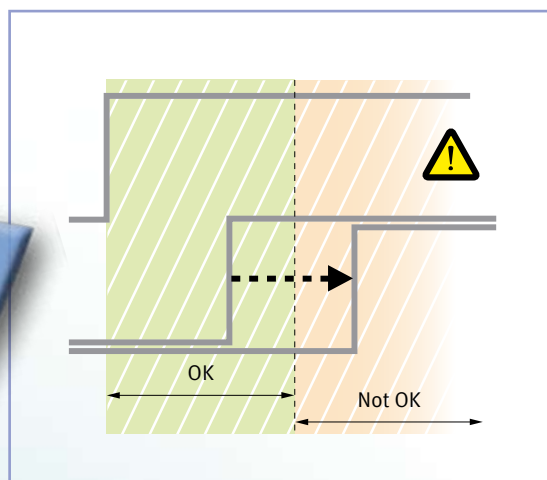

These warnings would be useless if you cannot easily find the underlying cause. Therefore, there are several convenient ways to access the information, with little or no PLC programming:

- Directly from the network maintenance view of CX-One
- By using Smart Active Parts on the NS-series HMIs
- By using predefined Function Blocks in the PLC.



### An integral component of Smart Platform

The SmartSlice remote I/O series was developed as a part of Omron's Smart Platform. Designed to make machine automation easy, Smart Platform provides seamless, drag-and-drop integration of all automation components in your machine. From sensor to controller, from HMI to drive, all devices are accessible through one connection using a single software suite, CX-One. Moreover, built-in distributed intelligence in Omron devices means that you spend less time in programming and troubleshooting.

### The Smart Platform concept is built around three key elements:

- **One software**  
*for your complete machine*
- **One connection**  
*to reach all your devices*
- **One minute**  
*to achieve what took you hours*



### Smart I/O to reduce your programming effort

SmartSlice analogue I/O units will also help you reduce PLC programming. Many useful functions are already built in, and only require some settings to match your application's characteristics. Some examples:

- Analogue value scaling takes place in the unit. Your PLC program and HMI will only see data in engineering units. No conversion is required, so programs will be shorter and easier to understand.
- Up to four alarm levels can be set per signal. Alarm settings are stored in the SmartSlice unit, and backed up in the

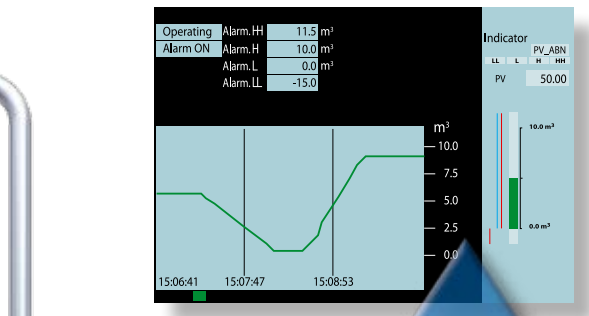
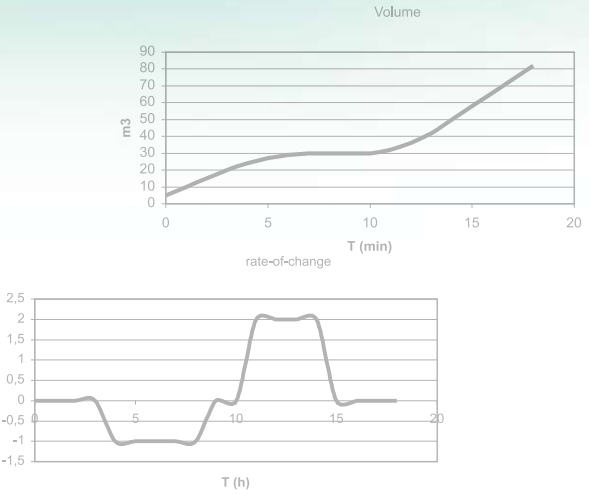

interface unit. This allows true hot-swapping, without having to set up the replacement unit.

- Time-based calculations on analogue data can be complex in a PLC. SmartSlice analogue inputs have built-in integration and rate-of-change calculation. Integration calculates a volume based on analogue flow measurement; rate-of-change calculation can be used to warn you that an analogue value is changing faster or slower than expected. This can help detect situations such as leakage, wear, or abnormal load.

# Smart and compact design

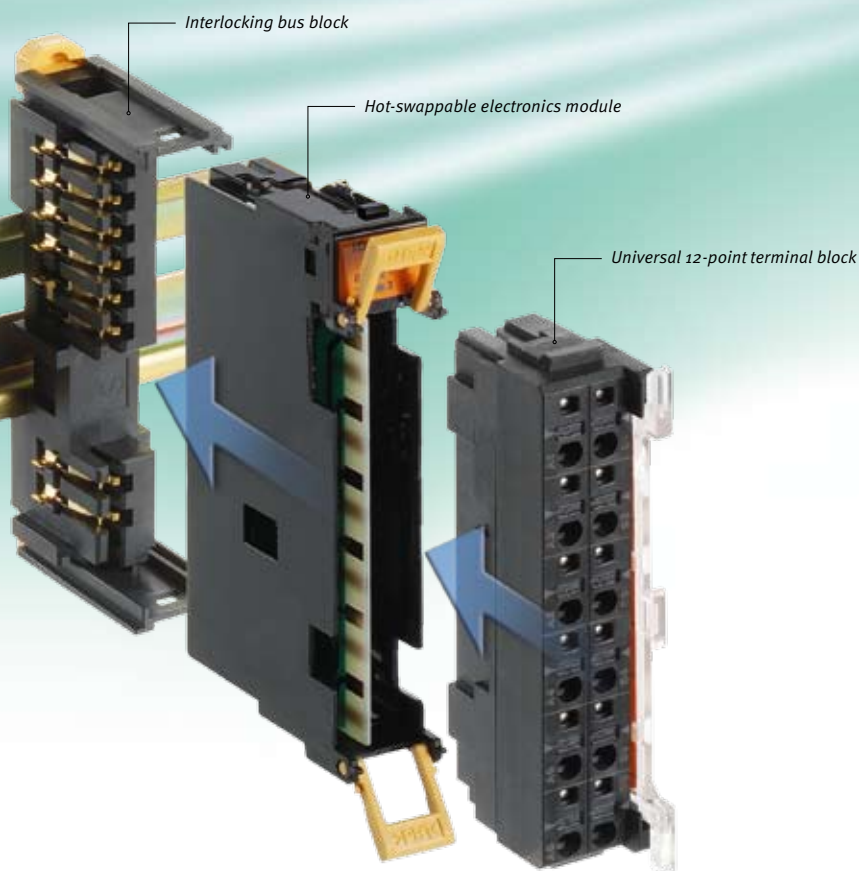

## Highly compact

More compact than any other modular I/O system – with a height of only 80 mm – SmartSlice takes up very little space in your control cabinet. With a 3-wire input connection there is no need for additional power distribution rails; all your field wiring, including sensor power supply, can be directly connected to the units.

## Reliable 3-piece construction

All SmartSlice modules have a 3-piece construction. Interlocking bus blocks build the backplane of the system. The electronics module and removable terminal block plug into the backplane, enabling you to:

- Replace electronic modules while the bus structure and field wiring stay intact. During hot-swapping, all other I/O units continue to operate.
- Detach I/O terminals for pre-wiring, maintenance or testing.

All contact surfaces between the electronics module and connectors are gold-plated for 100% reliable connections.



## Easy push-in wiring for quick installation

The SmartSlice terminal blocks provide fast and reliable screwless clamp connections. The 'push-in' design allows tool-less insertion of terminated wires. Each individual connection is equipped with a test point to help verification of connections during commissioning and troubleshooting. Each terminal block has a pull-out label holder showing the terminal assignment of the unit.

# The smart way to configure

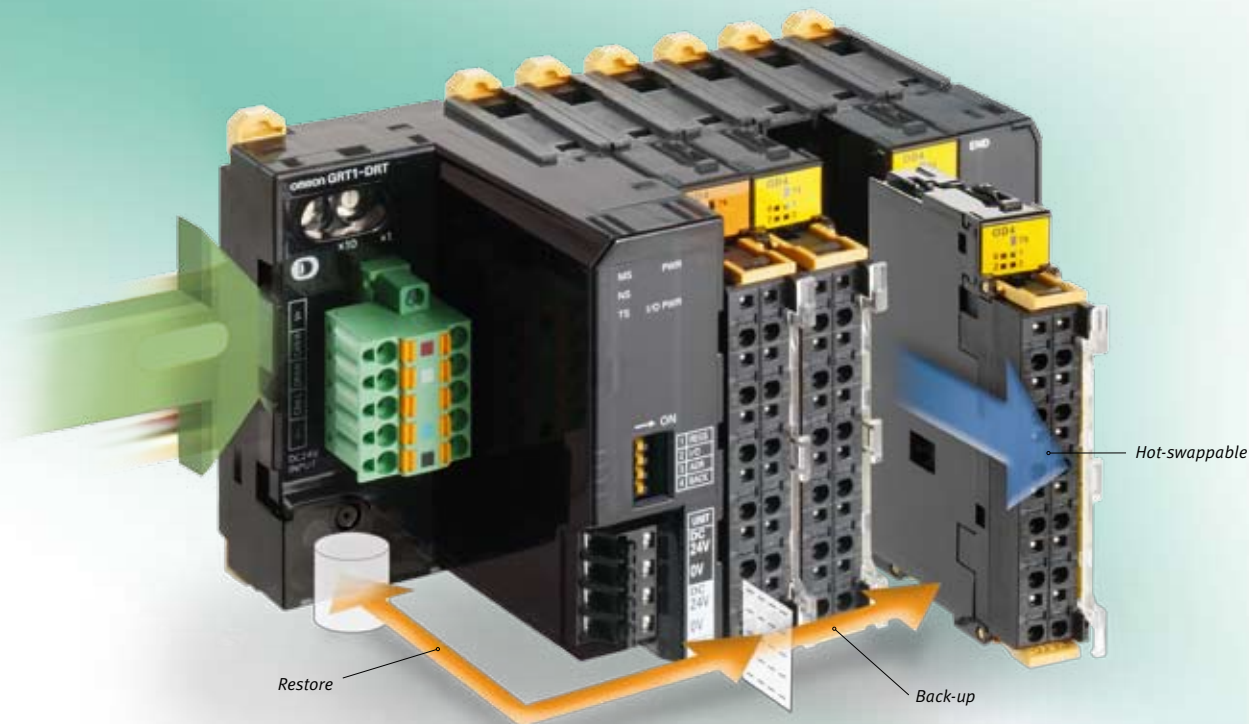

## Fast backup and restore

With all the intelligence and advanced functions in SmartSlice units, backup and recovery of settings are important to support fast maintenance and repair of your machine. These functions are therefore also tool-less in SmartSlice. All I/O unit data can be backed up in the bus interface unit at the flick of a switch. Recovery is even simpler; after hot-swapping a unit, all settings are automatically loaded.

## Tool-less replacement

Communication units for most networks are automatically reconfigured by the master unit upon replacement. For PROFINET, a special endplate is available that stores essential communication settings. This makes it possible to also replace PROFINET communication units on-site without having to connect a configuration tool. Ideal for maintenance in far-away places.

## Easy to setup and maintain

When used with Omron DeviceNet and CompoNet Master Units, no configuration is required at all. Simply set a bus address and connect. After startup, the I/O configuration can be stored with a single switch to make sure any incorrect change of units is detected. Configuration of the ProfiNet IO and Profibus is also easier than you expect; thanks to state-of-the-art FDT/DTM\* configuration tools, setting up a SmartSlice station will just take a minute. Integration in existing systems is never a problem; besides FDT/DTM, conventional configuration by GSD (ML) file is also supported.

Configuration tools for all supported networks are included in CX-One, Omron's unique all-in-one software suite for configuration, programming and monitoring of a complete automation system, from sensor to drive, from HMI to PLC. Transparent message routing built into Omron devices makes sure that you can reach them all through a single connection. Device status and preventive maintenance data are therefore always accessible.

## Variations are welcome

Production of modular machines suited to customer-specific demands requires flexibility in I/O count. SmartSlice allows virtual I/O units to be inserted in the configuration, so that the PLC program can remain the same for all machine variations.



\* FDT (Field Device Tool) technology standardizes the communication interface between field devices and application software. It is independent from the communication protocol and the software environment of either the device or the host system. A DTM (Device Type Manager) is a plug-in using this standard interface to add a device-specific user interface and communication channel to any FDT-based software tool. The combination FDT/DTM allows any device to be accessed from any host system through any protocol.

# SmartSlice

## The smartest modular I/O system

OMRON's SmartSlice I/O system is compact, intelligent and easy. When used with OMRON's CS1/CJ1 DeviceNet or CompoNet master units, no configuration tool is required. By using built-in functions such as pre-scaling, totalising, differentiation and alarming in analog I/O units, PLC programming can be minimised. Preventive maintenance data collected by all I/O units can be accessed using CX-Integrator or NS-series Smart Active Parts.

- Most compact in the market (84 mm high)
- Easy set-up, backup and restore functions
- Diagnostics and preventive maintenance data at I/O level
- Detachable terminal blocks allow hot-swapping without re-wiring
- 3-wire I/O connection with 'push-in' technology, no screw-driver required

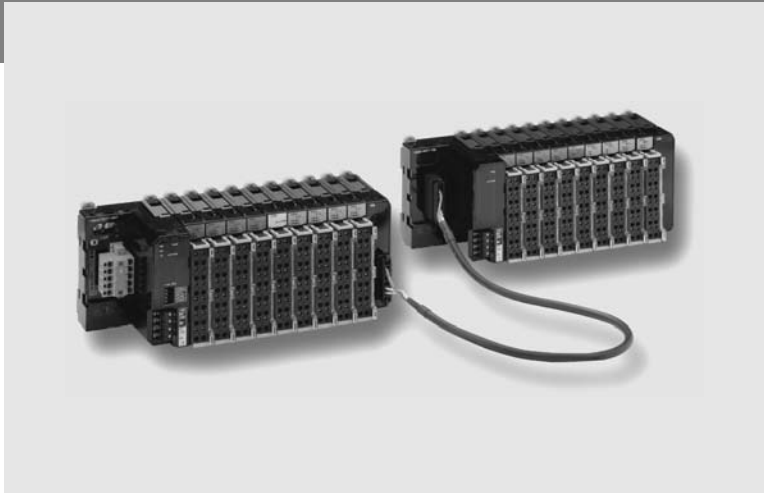

## System Configuration

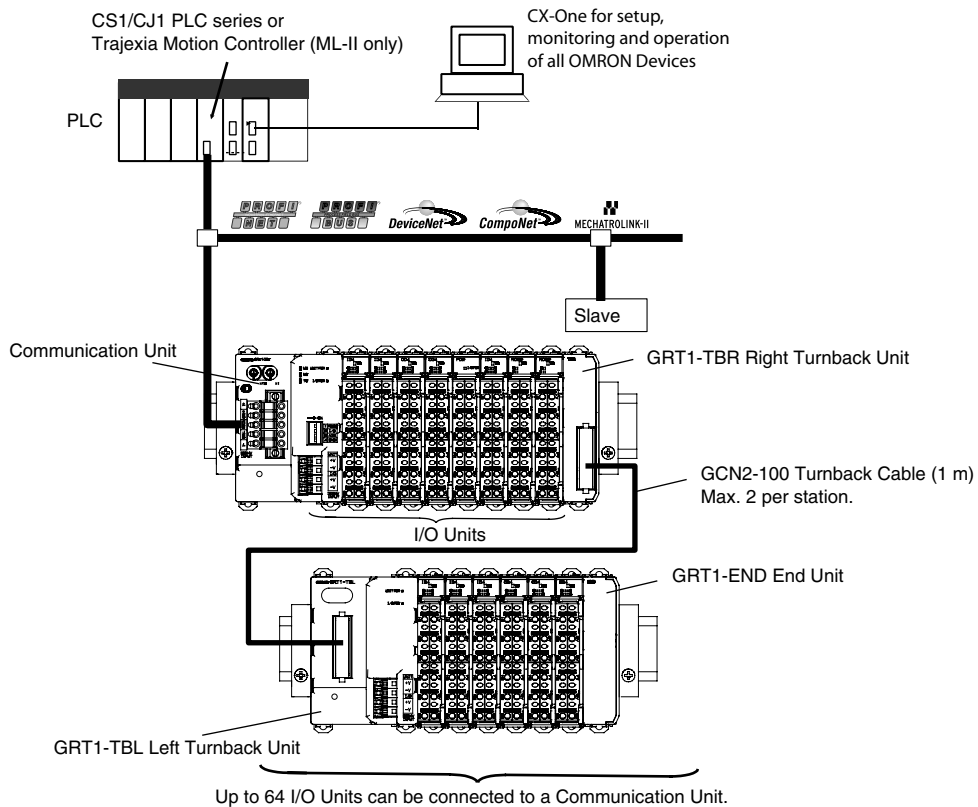



## Specifications

### General Specifications

Common SmartSlice Specifications	
Unit power supply voltage	24 VDC (20.4 to 26.4 VDC)
I/O power supply voltage	24 VDC (20.4 to 26.4 VDC)
I/O connection	Screwless push-in technology
Noise immunity	Conforms to IEC61000-4-4, 2.0 kV (power supply line)
Vibration resistance	10 to 60 Hz: 0.7 mm double amplitude 60 to 150 Hz: 50 m/s <sup>2</sup>
Shock resistance	150 m/s <sup>2</sup> , 3 times in each direction
Dielectric strength	500 VAC (between isolated circuits)
Insulation resistance	20 MΩ min. (between isolated circuits)
Ambient operating temperature	-10 to 55°C (with no icing or condensation)
Ambient operating humidity	25% to 85%
Operating environment	No corrosive gases
Ambient storage temperature	-25 to 65°C (with no icing or condensation)
Mounting	35 mm DIN rail

### Communication Units

Model name	GRT1-PNT	GRT1-PRT	GRT1-DRT	GRT1-CRT	GRT1-ML2
Network Specification	PROFINET-IO	PROFIBUS-DPV1	DeviceNet	CompoNet	MECHATROLINK-II for Trajexia
Network connector	2 x RJ45, built-in switch with support for MRP redundancy.	9-pin D-Sub	Open-style DeviceNet connector, dual screwless push-in dual connections.	4-pin CompoNet	2 x ML-II
Network interface power supply	Internal		External, 11 to 25 VDC, 22 mA	Internal	
Number of I/O points	1,024 inputs and outputs max. (128 bytes each)			32 bytes input + 32 bytes output max.	1,024 inputs and outputs max. (128 bytes each)
Number of connectable Units	64 SmartSlice I/O Units max.				
I/O power supply	24 VDC, 4 A max.				
Status flags	1 word for Communications Unit status flags				
Parameter backup and restore	up to 2 KB of data per I/O Unit.				

### Power Feed and Distribution Units

#### GRT1-PD2

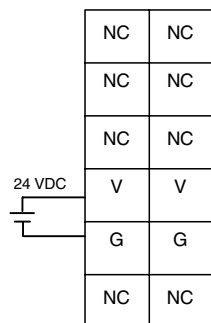

#### GRT1-PD2G

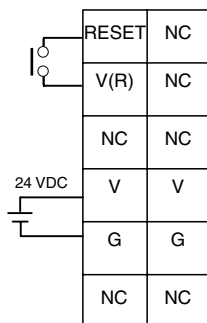

#### GRT1-PD8

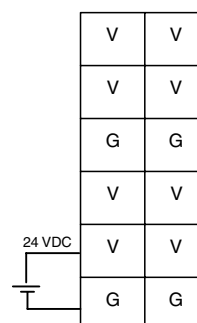

#### GRT1-PD8-1

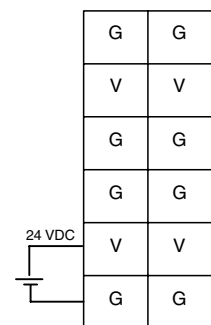

#### GRT1-PC8

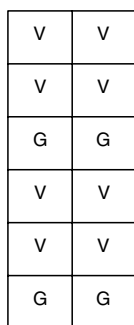

#### GRT1-PC8-1

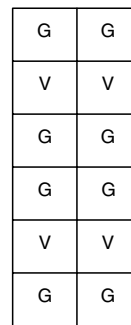

Digital Input Units

Model name	GRT1-ID4	GRT1-ID4-1	GRT1-ID8	GRT1-ID8-1
Signal type	DC input (for sinking outputs, NPN type)	DC input (for sourcing outputs, PNP type)	DC input (for sinking outputs, NPN type)	DC input (for sourcing outputs, PNP type)
Number of input points	4 inputs		8 inputs	
Power terminals	4 x V (24 V) + 4 x G (0 V)		4 x G (0 V)	4 x V (24 V)
ON voltage	15 VDC min.			
ON current	6 mA max./point (at 24 VDC)		4 mA max./point (at 24 VDC)	
OFF voltage	5 VDC max.			
OFF current	1 mA max.			
ON delay / OFF delay	1.5 ms max.			

Model name	GRT1-IA4-1	GRT1-IA4-2
Signal type	AC input, 110 V	AC input, 230 V
Number of input points	4 inputs	
Power terminals	None	
Input voltage	100 to 120 VAC -15% to +10%, 50/60 Hz	200 to 240 VAC -15% to +10%, 50/60 Hz
ON voltage	70 VAC min.	120 VAC min.
ON current	4 mA min.	
OFF voltage	20 VAC max.	
OFF current	2 mA max.	
ON delay / OFF delay	10 ms max./55 ms max.	10 ms max./40 ms max.

GRT1-ID4 (NPN)

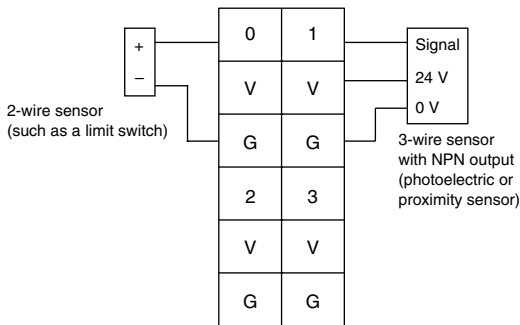

GRT1-ID4 -1 (PNP)

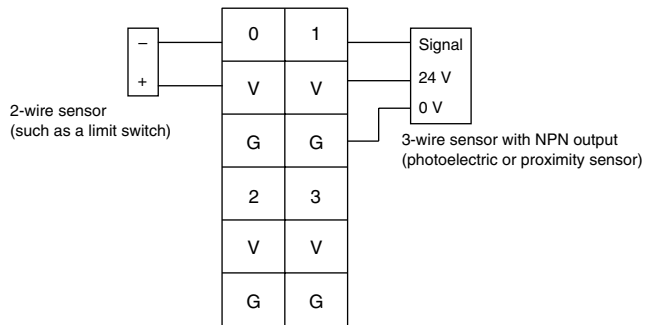

GRT1-IA4-1/GRT1-IA4-2

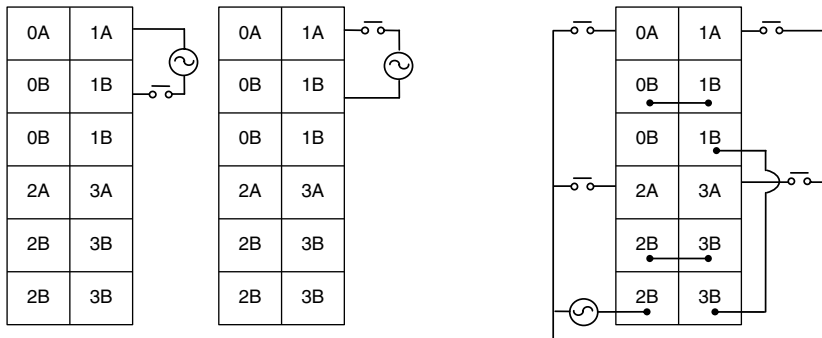

Note: No common signal for inputs.

Note: Common signal for four inputs.

GRT1-ID8 (NPN)

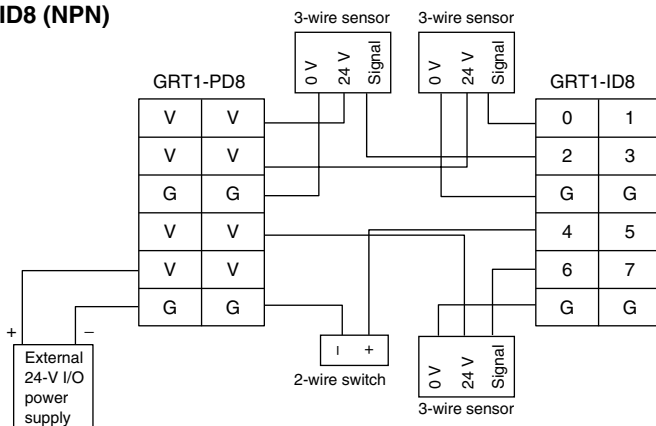

GRT1-ID8-1 (PNP)

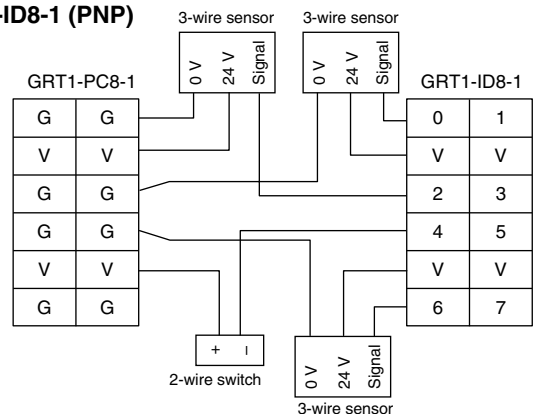

**Digital Output Units**

Model name	GRT1-OD4	GRT1-OD4-1	GRT1-OD4G-1	GRT1-OD4G-3
Signal type	Transistor output (NPN type, sinking)	Transistor output (PNP type, sourcing)	Transistor output (PNP type, sourcing), with short-circuit protection	
Number of output points	4 outputs			
Power terminals	4 x V (24 V)	4 x G (0 V)	4 x V (24 V) + 4 x G (0 V)	
Rated voltage	24 VDC (20.4 to 26.4 VDC)			24 V I/O power supply via the front terminal of the unit.
Rated output current	500 mA max./point			from 4 x 2.0 A at 30 °C to 4 x 1.0 A at 55 °C
Residual voltage	1.2 VDC max. (at 500 mA)			1.2 VDC max. (at 2 A)
Leakage current	0.1 mA max.			
ON delay / Off delay	0.5 / 1.5 ms max.			

Model name	GRT1-OD8	GRT1-OD8-1	GRT1-OD8G-1	GRT1-ROS2
Signal type	Transistor output (NPN type, sinking)	Transistor output (PNP type, sourcing)	Transistor output (PNP type, sourcing), with short-circuit protection	Relay output (normally open)
Number of output points	8 outputs			2 outputs (with 2 terminals per connection)
Power terminals	4 x V (24 V)	4 x G (0 V)	n.a.	
Rated voltage	24 VDC (20.4 to 26.4 VDC)			250 VAC / 24 VDC
Rated output current	500 mA max./point			2 A (min. 1 mA @ 5 VDC)
Residual voltage	1.2 VDC max. (at 500 mA)			-
Leakage current	0.1 mA max.			-
ON delay / Off delay	0.5 / 1.5 ms max.			15 ms max.
Mechanical life expectancy	-			20,000,000 times min.
Electrical life expectancy	-			100,000 times min.

**GRT1-OD4**

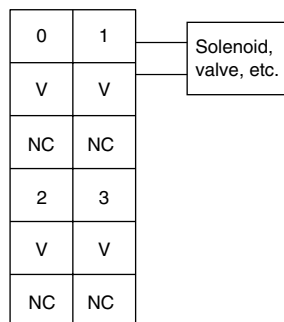

**GRT1-OD4-1**

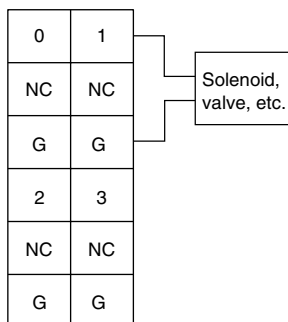

**GRT1-OD4G-1 (PNP)**

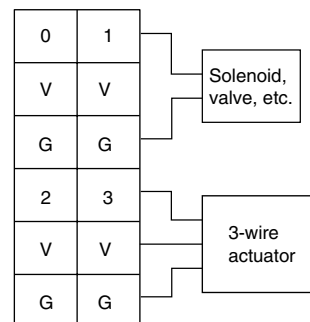

**GRT1-OD8 (NPN)**

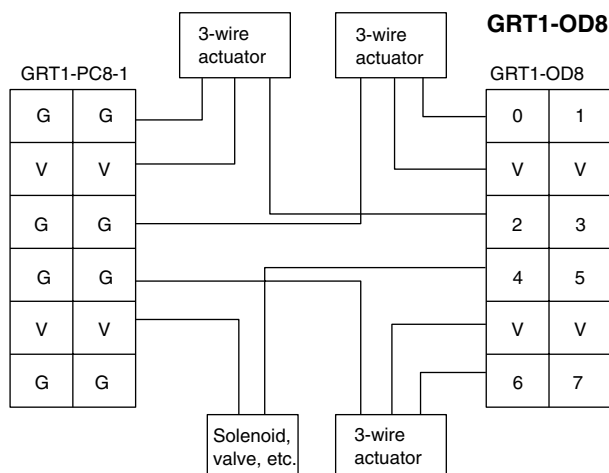

**GRT1-OD4G-3 (PNP)**

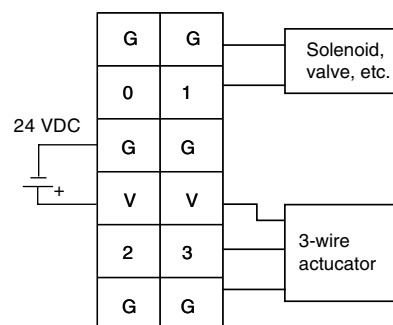

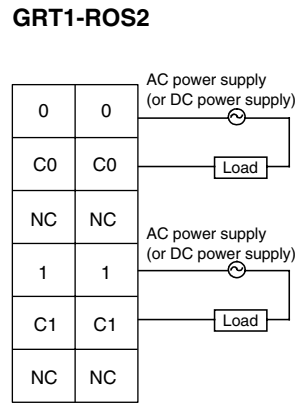
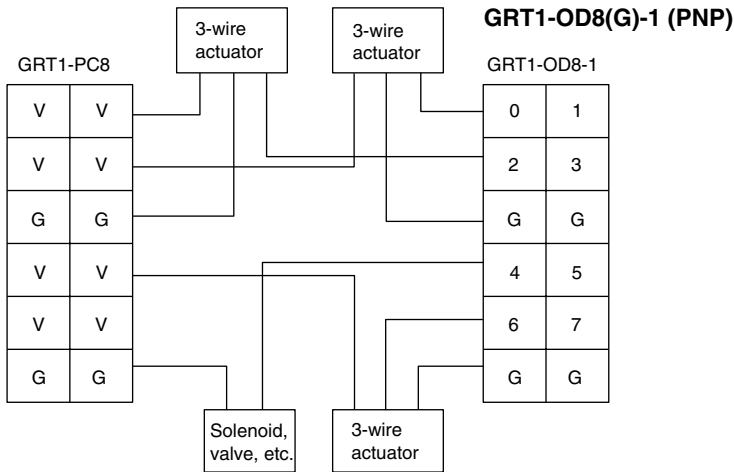

**Pulse I/O Units**

Model name	GRT1-CT1	GRT1-CT1-1	GRT1-CP1-L
Counter input	A/B incremental encoder, or pulse/direction, or pulse up/down	A/B incremental encoder, or pulse/direction, or pulse up/down	A/B/Z incremental encoder, or pulse/direction/reset
Counter signal type	24 VDC, NPN type	24 VDC, PNP type	24 VDC, PNP type, or RS422 Line driver levels
Max. frequency	60 kHz		100 kHz
Counter range	32 bit double signed integer		
Comparison values	1 range (2 comparison values)		2 independent ranges
Control Input	IN0, DC input (NPN type)   IN0, DC input (PNP type)		
Control Input functions	Capture, Preset, Reset		Capture, Preset, Reset, Z enable
Control Outputs	OUT0, Transistor Output (NPN, sinking)	OUT0, Transistor Output (PNP, sourcing)	OUT0, OUT1, Transistor Output (PNP, sourcing)
Control Output functions	Range comparison, manual override		
Additional functions	On-the-fly reconfiguration, Frequency measurement		

**GRT1-CT1(-1)**

GRT1-CT1 (NPN)		GRT1-CT1-1 (PNP)	
A	OUT	A	OUT
B	V	B	N.C.
Z/IN	N.C.	Z/IN	G
N.C.	N.C.	N.C.	N.C.
V	V	V	V
G	G	G	G

**GRT1-CP1-L**

24-V rotary encoder (all DIP switch pins ON)		Line driver rotary encoder (all DIP switch pins OFF)	
A	N.C.	A+	A-
B	N.C.	B+	B-
Z	N.C.	Z+	Z-
IN	OUT0	IN	OUT0
V	OUT1	V	OUT1
G	G	G	G

Analog I/O Units

Model name	GRT1-AD2	GRT1-DA2V	GRT1-DA2C
Signal type	Analog Input: 0-20mA, 4-20mA, ±10V, 0-10V, 0-5V, 1-5V	Analog Output: ±10V, 0-10V, 0-5V, 1-5V	Analog Output: 0-20mA, 4-20mA,
Number of points	2 inputs		
Resolution	1/6000 full scale		
Conversion time	2ms / 2points		

Model name	GRT1-TS2P	GRT1-TS2PK	GRT1-TS2T
Signal type	Temperature input, Pt100, (2-wire, 3-wire)	Temperature input, Pt1000, (2-wire, 3-wire)	Thermocouple, R, S, K, J, T, E, B, N, L, U, W, or PL2
Number of points	2 inputs		
Indication range	-200 to +200 °C / -200 to +850 °C		Depends on thremocouple type
Accuracy	±0.3% of PV or ±0.8 °C* (whichever is larger) ±1 digit max. * (or ±0.5 °C for -200 °C to +200 °C input range)		±2°C ±1 digit max. Mounting restrictions apply. See Operation Manual W455
Resolution	0.1 °C, 16-bit signed integer, or 0.01 °C, 32-bit signed double integer		
Conversion time	250 ms / 2 points		

GRT1-AD2

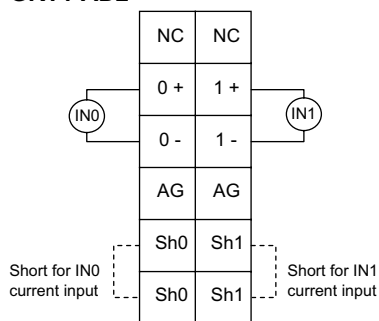

GRT1-DA2V

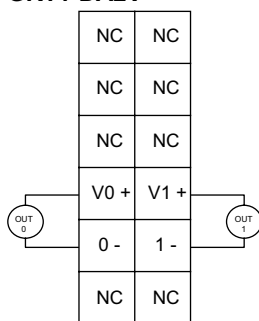

GRT1-DA2C

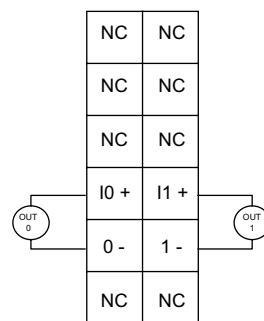

GRT1-TS2P/PK (2-wire)

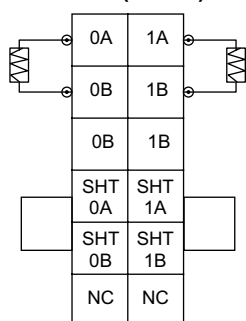

GRT1-TS2P/PK (3-wire)

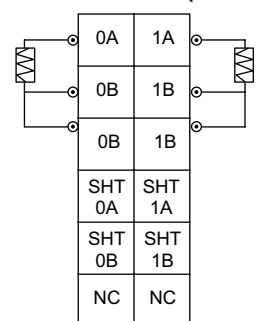

GRT1-TS2T

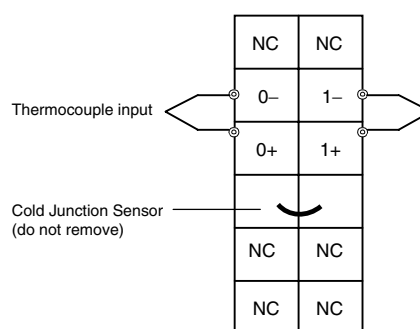

Dimensions

I/O-units

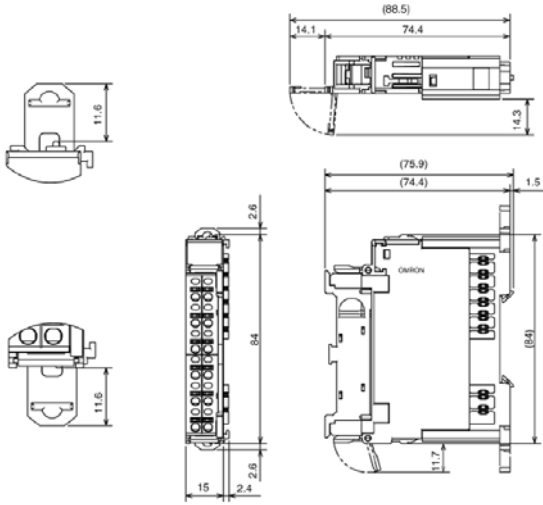

Communication Units

- GRT1-CRT
- GRT1-DRT
- GRT1-ML2
- GRT1-PNT
- GRT1-PRT
- GRT1-TBL

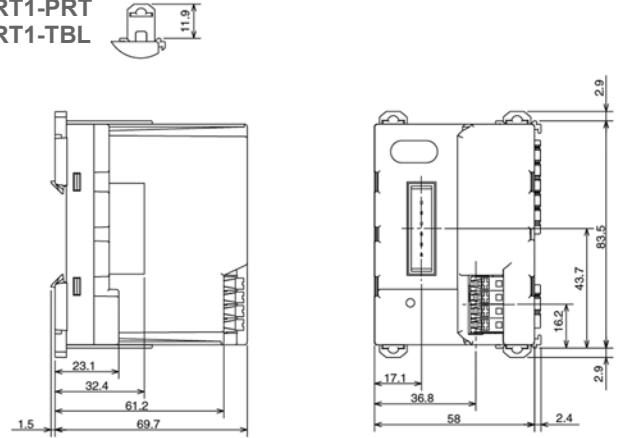

End units

- GRT1-END
- GRT1-END-M
- GRT1-TBR

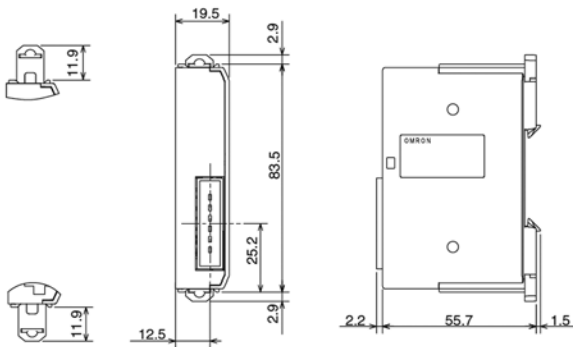

Ordering Information

Communication Units

Function	Specification		Model code
DeviceNet interface unit	For up to 64 I/O units	84x58x70	GRT1-DRT
CompoNet interface unit	For up to 64 I/O units (limited to 32 byte in + 32 byte out)	84x58x70	GRT1-CRT
PROFIBUS-DP interface unit	For up to 64 I/O units	84x58x70	GRT1-PRT
PROFINET-IO interface unit	For up to 64 I/O units	84x58x70	GRT1-PNT <sup>1</sup>
MECHATROLINK-II interface unit	For up to 64 I/O units (slave to Trajexia motion controller)	84x58x70	GRT1-ML2
End plate	One unit required per bus interface	84x20x58	GRT1-END
End plate with memory function	Supports toolless replacement of PROFINET-IO interface unit	84x20x58	GRT1-END-M <sup>1</sup>

<sup>1</sup> Available 09-2008

## Ordering Information

### I/O units

Function	Specification		Model code
4 NPN inputs	24 VDC, 6 mA, 3-wire connection	84x15x74	GRT1-ID4
4 PNP inputs	24 VDC, 6 mA, 3-wire connection	84x15x74	GRT1-ID4-1
8 NPN inputs	24 VDC, 4 mA, 1-wire connection + 4xG	84x15x74	GRT1-ID8
8 PNP inputs	24 VDC, 4 mA, 1-wire connection + 4xV	84x15x74	GRT1-ID8-1
4 AC inputs	110 VAC, 2-wire connection	84x15x74	GRT1-IA4-1
4 AC inputs	230 VAC, 2-wire connection	84x15x74	GRT1-IA4-2
4 NPN outputs	24 VDC, 500 mA, 2-wire connection	84x15x74	GRT1-OD4
4 PNP outputs	24 VDC, 500 mA, 2-wire connection	84x15x74	GRT1-OD4-1
4 PNP outputs with short-circuit protection	24 VDC, 500 mA, 3-wire connection	84x15x74	GRT1-OD4G-1
4 PNP outputs with short-circuit protection	24 VDC, 2 A, 2-wire connection	84x15x74	GRT1-OD4G-3
8 NPN outputs	24 VDC, 500 mA, 1-wire connection + 4xV	84x15x74	GRT1-OD8
8 PNP outputs	24 VDC, 500 mA, 1-wire connection + 4xG	84x15x74	GRT1-OD8-1
8 PNP outputs with short-circuit protection	24 VDC, 500 mA, 1-wire connection + 4xG	84x15x74	GRT1-OD8G-1
2 relay outputs	240 VAC, 2A, normally-open contacts	84x15x74	GRT1-ROS2
60 kHz Counter unit, NPN	A+B encoder inputs + 1 Z/control input + 1 output (NPN-type)	84x15x74	GRT1-CT1
60 kHz Counter unit, PNP	A+B encoder inputs + 1 Z/control input + 1 output (PNP-type)	84x15x74	GRT1-CT1-1
100 kHz Counter / Positioner unit	A+B+Z encoder inputs (line driver or 24 V selectable) + 1 control input + 2 outputs (PNP-type)	84x15x74	GRT1-CP1-L
2 analog inputs, current/voltage	±10 V, 0-10 V, 0-5 V, 1-5 V, 0-20 mA, 4-20 mA	84x15x74	GRT1-AD2
2 analog outputs, voltage	±10 V, 0-10 V, 0-5 V, 1-5 V	84x15x74	GRT1-DA2V
2 analog outputs, current	0-20 mA, 4-20 mA	84x15x74	GRT1-DA2C
2 Pt100 inputs	Pt100, 2-wire or 3-wire connection	84x15x74	GRT1-TS2P
2 Pt1000 inputs	Pt1000, 2-wire or 3-wire connection	84x15x74	GRT1-TS2PK
2 Thermocouple inputs	Types B, E, J, K, N, R, S, T, U, W, PL2, with cold junction compensation	84x15x74	GRT1-TS2T

### Other units

Function		Model code
I/O power feed unit, separates power supply between groups of I/O units	84x15x74	GRT1-PD2
I/O power feed unit with electronic overload protection, separates power supply between groups of I/O units	84x15x74	GRT1-PD2G
I/O power feed and distribution unit, separates power supply between groups of I/O units, 8xV + 4xG	84x15x74	GRT1-PD8
I/O power feed and distribution unit, separates power supply between groups of I/O units, 4xV + 8xG	84x15x74	GRT1-PD8-1
I/O power connection unit, 8xV + 4xG	84x15x74	GRT1-PC8
I/O power connection unit, 4xV + 8xG	84x15x74	GRT1-PC8-1
Turnback Unit, right-hand side	84x20x58	GRT1-TBR
Turnback Unit, left-hand side	84x58x70	GRT1-TBL
Turnback cable, one meter	1 m	GCN2-100

### Accessories

Function	Model code
Replacement front connectors, pack of 5 pcs.	GRT1-BT1-5
PROFIBUS-DP connector, 9-pin D-sub	PROFIBUS Connector 839550
PROFIBUS-DP connector, 9-pin D-sub, with bus termination	PROFIBUS Term. Conn. 846086
CompoNet screw terminal connector (order per 10 pcs)	DCN4-TB4
CompoNet branch line connector (order per 10 pcs)	DCN4-BR4
CompoNet Y-connector (order per 10 pcs)	DCN4-MD4

### Master Units

Function	Model code
PROFINET-IO Controller for CJ1-series PLCs	CJ1W-PNT21 <sup>1</sup>
PROFIBUS-DP Master Unit for CS1-series PLCs	CS1W-PRM21
PROFIBUS-DP Master Unit for CJ1-series PLCs	CJ1W-PRM21
DeviceNet Master Unit for CS1-series PLCs	CS1W-DRM21-V1
DeviceNet Master Unit for CJ1-series PLCs	CJ1W-DRM21
CompoNet Master Unit for CS1-series PLCs	CS1W-CRM21
CompoNet Master Unit for CJ1-series PLCs	CJ1W-CRM21
MECHATROLINK-II Master Unit for Trajexia (4 stations max.)	TJ1-ML04
MECHATROLINK-II Master Unit for Trajexia (16 stations max.)	TJ1-ML16
HMI with PLC and DeviceNet Master	NSJxx-T□□□□-G5D
HMI with PLC and PROFIBUS-DP Master	NSJxx-T□□□□-G5P

<sup>1</sup> Available 09-2008

### Software

Function	Model code
CX-One, Omron's integrated software for programming and configuration of all control system components, including PLCs, remote I/O, HMI, servo drives, inverters, temperature controllers and advanced sensors.	CX-ONE-AL□□ C-E □□ = number of licenses (01, 03, 10)

**OMRON EUROPE B.V.** Wegalaan 67-69, NL-2132 JD, Hoofddorp, The Netherlands. Tel: +31 (0) 23 568 13 00 Fax: +31 (0) 23 568 13 88 [www.industrial.omron.eu](http://www.industrial.omron.eu)

**Austria**

Tel: +43 (0) 2236 377 800  
[www.industrial.omron.at](http://www.industrial.omron.at)

**Belgium**

Tel: +32 (0) 2 466 24 80  
[www.industrial.omron.be](http://www.industrial.omron.be)

**Czech Republic**

Tel: +420 234 602 602  
[www.industrial.omron.cz](http://www.industrial.omron.cz)

**Denmark**

Tel: +45 43 44 00 11  
[www.industrial.omron.dk](http://www.industrial.omron.dk)

**Finland**

Tel: +358 (0) 207 464 200  
[www.industrial.omron.fi](http://www.industrial.omron.fi)

**France**

Tel: +33 (0) 1 56 63 70 00  
[www.industrial.omron.fr](http://www.industrial.omron.fr)

**Germany**

Tel: +49 (0) 2173 680 00  
[www.industrial.omron.de](http://www.industrial.omron.de)

**Hungary**

Tel: +36 1 399 30 50  
[www.industrial.omron.hu](http://www.industrial.omron.hu)

**Italy**

Tel: +39 02 326 81  
[www.industrial.omron.it](http://www.industrial.omron.it)

**Middle East & Africa**

Tel: +31 (0) 23 568 11 00  
[www.industrial.omron.eu](http://www.industrial.omron.eu)

**Netherlands**

Tel: +31 (0) 23 568 11 00  
[www.industrial.omron.nl](http://www.industrial.omron.nl)

**Norway**

Tel: +47 (0) 22 65 75 00  
[www.industrial.omron.no](http://www.industrial.omron.no)

**Poland**

Tel: +48 (0) 22 645 78 60  
[www.industrial.omron.pl](http://www.industrial.omron.pl)

**Portugal**

Tel: +351 21 942 94 00  
[www.industrial.omron.pt](http://www.industrial.omron.pt)

**Russia**

Tel: +7 495 648 94 50  
[www.industrial.omron.ru](http://www.industrial.omron.ru)

**Spain**

Tel: +34 913 777 900  
[www.industrial.omron.es](http://www.industrial.omron.es)

**Sweden**

Tel: +46 (0) 8 632 35 00  
[www.industrial.omron.se](http://www.industrial.omron.se)

**Switzerland**

Tel: +41 (0) 41 748 13 13  
[www.industrial.omron.ch](http://www.industrial.omron.ch)

**Turkey**

Tel: +90 216 474 00 40  
[www.industrial.omron.com.tr](http://www.industrial.omron.com.tr)

**United Kingdom**

Tel: +44 (0) 870 752 08 61  
[www.industrial.omron.co.uk](http://www.industrial.omron.co.uk)

**More Omron representatives**  
[www.industrial.omron.eu](http://www.industrial.omron.eu)

*Authorised Distributor:*

**Control Systems**

• Programmable logic controllers • Human-machine interfaces • Remote I/O

**Motion & Drives**

• Motion controllers • Servo systems • Inverters

**Control Components**

• Temperature controllers • Power supplies • Timers • Counters • Programmable relays  
• Digital panel indicators • Electromechanical relays • Monitoring products • Solid-state relays  
• Limit switches • Pushbutton switches • Low voltage switch gear

**Sensing & Safety**

• Photoelectric sensors • Inductive sensors • Capacitive & pressure sensors • Cable connectors  
• Displacement & width-measuring sensors • Vision systems • Safety networks • Safety sensors  
• Safety units/relay units • Safety door/guard lock switches