



# MX2 DeviceNet Option Board

Born to drive machines

Model: 3G3AX-MX2-DRT-E

## USER'S MANUAL



**OMRON**

## **Notice:**

OMRON products are manufactured for use according to proper procedures by a qualified operator and only for the purposes described in this manual.

The following conventions are used to indicate and classify precautions in this manual. Always heed the information provided with them. Failure to heed precautions can result in injury to people or damage to property.

## **OMRON Product References**

All OMRON products are capitalized in this manual. The word "Unit" is also capitalized when it refers to an OMRON product, regardless of whether or not it appears in the proper name of the product.

## **Trademarks and Copyrights**

DeviceNet is trademark of Open DeviceNet Vendor Association, Inc.

Other product names and company names in this manual are trademarks or registered trademarks of their respective companies.

The copyright of the 3G3AX-MX2-DRT-E Option Board belongs to OMRON Corporation.

## **Intended Audience**

This manual is intended for the following personnel, who must also have knowledge of electrical systems (an electrical engineer or the equivalent).

- Personnel in charge of installing FA systems.
- Personnel in charge of designing FA systems.
- Personnel in charge of managing FA systems and facilities.
- Personnel in charge of maintaining FA systems.

## **© OMRON, 2010**

All rights reserved. No part of this publication may be reproduced, stored in a retrieval system, or transmitted, in any form, or by any means, mechanical, electronic, photocopying, recording, or otherwise, without the prior written permission of OMRON.

No patent liability is assumed with respect to the use of the information contained herein. Moreover, because OMRON is constantly striving to improve its high-quality products, the information contained in this manual is subject to change without notice. Every precaution has been taken in the preparation of this manual. Nevertheless, OMRON assumes no responsibility for errors or omissions. Neither is any liability assumed for damages resulting from the use of the information contained in this publication.

## About this Manual

This manual describes the 3G3AX-MX2-DRT-E DeviceNet Option Board for OMRON's MX2-A□ Inverter. It also describes how to install and operate the Unit.

Please read this manual carefully so that you understand the information provided before installing or using the 3G3AX-MX2-DRT-E Option Board. Start with the precautions in the following section. They describe the operating environment and application safety measures which must be observed prior to and when using the 3G3AX-MX2-DRT-E Option Board.

Please be sure to read the related user manuals to use the 3G3AX-MX2-DRT-E Option Board safely and properly. Be sure you are using the most current version of the manual:

Manual	Contents	Cat No.
MX2 User's Manual	Describes the installation and operation of the MX2-A□ Inverter	I570
DeviceNet Operation Manual	Describes the configuration and construction of a DeviceNet network, including installation procedures and specifications for cables, connectors, and other connection devices, as well as information on functions, operating procedures, and applications.	W267
DeviceNet CS/CJ Series Units Operation Manual	Describes the models, specifications, functions, operating procedures, and applications of CS-series and CJ-series DeviceNet Master Units.	W380

# Warranty and Limitations of Liability

## WARRANTY

OMRON's exclusive warranty is that the products are free from defects in materials and workmanship for a period of one year (or other period if specified) from date of sale by OMRON.

OMRON MAKES NO WARRANTY OR REPRESENTATION, EXPRESS OR IMPLIED, REGARDING NONINFRINGEMENT, MERCHANTABILITY, OR FITNESS FOR PARTICULAR PURPOSE OF THE PRODUCTS. ANY BUYER OR USER ACKNOWLEDGES THAT THE BUYER OR USER ALONE HAS DETERMINED THAT THE PRODUCTS WILL SUITABLY MEET THE REQUIREMENTS OF THEIR INTENDED USE. OMRON DISCLAIMS ALL OTHER WARRANTIES, EXPRESS OR IMPLIED.

## LIMITATIONS OF LIABILITY

OMRON SHALL NOT BE RESPONSIBLE FOR SPECIAL, INDIRECT, OR CONSEQUENTIAL DAMAGES, LOSS OF PROFITS OR COMMERCIAL LOSS IN ANY WAY CONNECTED WITH THE PRODUCTS, WHETHER SUCH CLAIM IS BASED ON CONTRACT, WARRANTY, NEGLIGENCE, OR STRICT LIABILITY.

In no event shall the responsibility of OMRON for any act exceed the individual price of the product on which liability is asserted.

IN NO EVENT SHALL OMRON BE RESPONSIBLE FOR WARRANTY, REPAIR, OR OTHER CLAIMS REGARDING THE PRODUCTS UNLESS OMRON'S ANALYSIS CONFIRMS THAT THE PRODUCTS WERE PROPERLY HANDLED, STORED, INSTALLED, AND MAINTAINED AND NOT SUBJECT TO CONTAMINATION, ABUSE, MISUSE, OR INAPPROPRIATE MODIFICATION OR REPAIR.

# Application Considerations

## SUITABILITY FOR USE

OMRON shall not be responsible for conformity with any standards, codes, or regulations that apply to the combination of products in the customer's application or use of the products.

At the customer's request, OMRON will provide applicable third party certification documents identifying ratings and limitations of use that apply to the products. This information by itself is not sufficient for a complete determination of the suitability of the products in combination with the end product, machine, system, or other application or use.

The following are some examples of applications for which particular attention must be given. This is not intended to be an exhaustive list of all possible uses of the products, nor is it intended to imply that the uses listed may be suitable for the products:

- o Outdoor use, uses involving potential chemical contamination or electrical interference, or conditions or uses not described in this manual.
- o Nuclear energy control systems, combustion systems, railroad systems, aviation systems, medical equipment, amusement machines, vehicles, safety equipment, and installations subject to separate industry or government regulations.
- o Systems, machines, and equipment that could present a risk to life or property.

Please know and observe all prohibitions of use applicable to the products.

NEVER USE THE PRODUCTS FOR AN APPLICATION INVOLVING SERIOUS RISK TO LIFE OR PROPERTY WITHOUT ENSURING THAT THE SYSTEM AS A WHOLE HAS BEEN DESIGNED TO ADDRESS THE RISKS, AND THAT THE OMRON PRODUCTS ARE PROPERLY RATED AND INSTALLED FOR THE INTENDED USE WITHIN THE OVERALL EQUIPMENT OR SYSTEM.

## ***Disclaimers***

### **PROGRAMMABLE PRODUCTS**

OMRON shall not be responsible for the user's programming of a programmable product, or any consequence thereof.

### **CHANGE IN SPECIFICATIONS**

Product specifications and accessories may be changed at any time based on improvements and other reasons. It is our practice to change model numbers when published ratings or features are changed, or when significant construction changes are made. However, some specifications of the products may be changed without any notice. When in doubt, special model numbers may be assigned to fix or establish key specifications for your application on your request. Please consult with your OMRON representative at any time to confirm actual specifications of purchased products.

### **DIMENSIONS AND WEIGHTS**

Dimensions and weights are nominal and are not to be used for manufacturing purposes, even when tolerances are shown.

### **PERFORMANCE DATA**

Performance data given in this manual is provided as a guide for the user in determining suitability and does not constitute a warranty. It may represent the result of OMRON's test conditions, and the users must correlate it to actual application requirements. Actual performance is subject to the OMRON Warranty and Limitations of Liability.

### **ERRORS AND OMISSIONS**

The information in this manual has been carefully checked and is believed to be accurate; however, no responsibility is assumed for clerical, typographical, or proof-reading errors, or omissions.



# Table of contents

<b>Safety Messages</b> .....	<b>ix</b>
1 Hazardous High Voltage .....	ix
2 General Precautions - Read These First! .....	x
3 Installation Precautions .....	xi
4 Configuration Precautions .....	xi
5 Application Precautions .....	xii
6 Operating Environment Precautions .....	xiii
7 Handling, Storage and Disposal .....	xiii
8 Compliance with EC Directives .....	xiii
<b>SECTION 1</b>	
<b>Getting Started</b> .....	<b>1</b>
1-1 Introduction .....	1
1-2 Option Board Specifications .....	3
1-3 Introduction to DeviceNet .....	4
<b>SECTION 2</b>	
<b>Option Board Mounting and Installation</b> .....	<b>7</b>
2-1 Orientation to Option Board Features .....	7
2-2 Basic System Description .....	9
2-3 Step-by-Step Basic Installation .....	9
<b>SECTION 3</b>	
<b>Configuring Drive Parameters and Option Board</b> .....	<b>15</b>
3-1 Installation of EDS files .....	15
3-2 Configuring the Option Board .....	15
3-3 Configuring the Network .....	18
<b>SECTION 4</b>	
<b>Operations and Monitoring</b> .....	<b>21</b>
4-1 Setting up inverter .....	21
4-2 Operating the Motor .....	22
4-3 .....	Overrid-
ing Inverter inputs .....	23
4-4 Controlling Inverter Torque .....	23
4-5 Faults and Trips .....	25
4-6 Accessing Parameters .....	26
4-7 Flexible Format .....	27
4-8 Limitations Caused by Inverter Mode and Rating Selection .....	30
4-9 Monitoring additional Inverter status using COS .....	30
<b>SECTION 5</b>	
<b>Troubleshooting and Maintenance</b> .....	<b>33</b>
5-1 Troubleshooting Using the LED Indicators .....	33
5-2 Other Error Causes and Error Procedures .....	37
5-3 Maintenance and Inspection .....	38
<b>APPENDIX A</b>	
<b>Glossary</b> .....	<b>41</b>

**APPENDIX B**

<b>Assembly Specification</b> .....	<b>43</b>
B-1 Basic Speed Control IO (20/70) .....	43
B-2 Extended Speed Control IO (21/71) .....	44
B-3 Extended Speed and Torque Control IO (123/173) .....	45
B-4 Special IO (100/150) .....	47
B-5 Extended Control IO (101/151/153) .....	48
B-6 Extended Speed and Acceleration Control IO (110/111) .....	51

**APPENDIX C**

<b>General Object Specification</b> .....	<b>55</b>
C-1 Identity Object (Class 0x01) .....	55
C-2 Message Router Object (Class 0x02) .....	56
C-3 DeviceNet Object (Class 0x03) .....	56
C-4 Assembly Object (Class 0x04) .....	58
C-5 Connection Object (Class 0x05) .....	59
C-6 Discrete Input Point Object (Class 0x08) .....	63
C-7 Discrete Output Point Object (Class 0x09) .....	63
C-8 Unit Parameter Object (Class 0x94) .....	64

**APPENDIX D**

<b>AC Drive Object Specification</b> .....	<b>65</b>
D-1 Motor Data Object (Class 0x28) .....	65
D-2 Control Supervisor Object (Class 0x29) .....	66
D-3 AC/DC Drive Object (Class 0x2A) .....	69

**APPENDIX E**

<b>DeviceNet Explicit Messages</b> .....	<b>71</b>
E-1 Basic Format of Explicit Messages .....	71
E-2 Function Code Object (Class 0x65) .....	73
E-3 Modbus Register Object (Class 0x64) .....	75
E-4 Explicit Message Error Codes .....	77

**APPENDIX F**

<b>Flexible Format</b> .....	<b>79</b>
<b>Table index</b> .....	<b>81</b>
<b>Revision history</b> .....	<b>83</b>





# Safety Messages

For the best results with the MX2-A□ Inverter, carefully read this manual and all of the warning labels attached to the Inverter before installing and operating it, and follow the instructions exactly. Keep this manual handy for quick reference.

## Definitions and Symbols

A safety instruction (message) includes a "Safety Alert Symbol" and a signal word or phrase such as WARNING or CAUTION. Each signal word has the following meaning:

-  **HIGH VOLTAGE** Indicates a potentially hazardous situation which, if not avoided, could result in electric shock. It calls your attention to items or operations that could be dangerous to you and other persons operating this equipment.  
Read the message and follow the instructions carefully.
-  **WARNING** Indicates a potentially hazardous situation which, if not avoided, could result in death or serious injury. Additionally, there may be severe property damage.
-  **Caution** Indicates a potentially hazardous situation, which, if not avoided, may result in minor or moderate injury, or property damage.
- Step 1** Indicates a step in a series of action steps required to accomplish a goal. The number of the step will be contained in the step symbol.
- Note** Notes indicate an area or subject of special merit, emphasizing either the product's capability or common errors in operation or maintenance.
- Tip** Tips give a special instruction that can save time or provide other benefits while installing or using the product. The tip calls attention to an idea that may not be obvious if you are a first-time user of the product.

## 1 Hazardous High Voltage

-  **HIGH VOLTAGE** Motor control equipment and electronic controllers are connected to hazardous line voltages. When servicing drives and electronic controllers, there may be exposed components with housing or protrusions at or above line potential. Extreme care should be taken to protect against shock.
- Stand on an insulating pad and make it a habit to use only one hand when checking components. Always work with another person in case an emergency occurs. Disconnect power before checking controllers or performing maintenance. Be sure equipment is properly grounded. Wear safety glasses whenever working on electronic controllers or rotating machinery.

## **2 General Precautions - Read These First!**

 **WARNING** Failure to read and understand the information provided in this manual may result in personal injury or death, damage to the product, or product failure. Please read each section in its entirety and be sure you understand the information provided in the section and related sections before attempting any of the procedures or operations given.

 **WARNING** This equipment should be installed, adjusted, and serviced by qualified electrical maintenance personnel familiar with the construction and operation of the equipment and the hazards involved. Failure to observe this precaution could result in bodily injury.

 **WARNING** Wiring, maintenance or inspection must be performed by authorized personnel. Not doing so may result in electrical shock or fire.

 **WARNING** Hazard of electrical shock! Disconnect incoming power before working on the OMRON 3G3AX-MX2-DRT-E DeviceNet Option Board or the MX2-A□ Inverter.

 **HIGH VOLTAGE** Turn the power supply OFF and wait for the time specified on the Option Board front cover before performing wiring, maintenance or inspection. Not doing so may result in electrical shock.

The OMRON 3G3AX-MX2-DRT-E DeviceNet Option Board is attached to an MX2-A□ Inverter. Dangerous voltage exists until the MX2-A□ Inverter power light is OFF.

 **HIGH VOLTAGE** Do not touch the conductive parts such as the internal PCB, terminals or connector while power is being supplied. Doing so may result in electrical shock.

 **WARNING** Do not attempt to take an Option Board apart or touch any internal parts while the power is being supplied. Doing so may result in electric shock.

 **WARNING** Do not attempt to disassemble, repair, or modify an Option Board. Any attempt to do so may result in malfunction, fire, or electric shock.

 **WARNING** Provide emergency stop circuits, interlock circuits, limit circuits and similar safety measures in external circuits (NOT in the Option Board). This ensures safety in the system if an abnormality occurs due to malfunction of the Option Board or another external factor affecting the Option Board operation. Not doing so may result in serious accidents.

 **WARNING** Fail-safe measures must be taken by the customer to ensure safety in the event of incorrect, missing, or abnormal signals caused by broken signal lines, momentary power interruptions, or other causes. Not doing so may result in serious accidents.

 **Caution** Do not touch the Inverter during power on, and immediately after power off. Hot surface may cause injury.

-  **Caution** The product will be used to control an adjustable speed drive connected to high voltage sources and rotating machinery that is inherently dangerous if not operated safely. Interlock all energy sources, hazardous locations, and guards in order to restrict the exposure of personnel to hazards. The adjustable speed drive may start the motor without warning. Signs on the equipment installation must be posted to this effect. A familiarity with auto-restart settings is a requirement when controlling adjustable speed drives. Failure of external or ancillary components may cause intermittent system operation, i.e., the system may start the motor without warning or may not stop on command. Improperly designed or improperly installed system interlocks and permissives may render a motor unable to start or stop on command.

### 3 Installation Precautions

-  **WARNING** Always connect the grounding cable to one of the ground terminals of the MX2-A□ Inverter. Failure to abide could lead to serious or possibly fatal injury.

-  **Caution** Failure to observe these precautions could lead to faulty operation of the Option Board or the Inverter, or could damage either of the two. Always read these precautions.

- Install external breakers and take other safety measures against short-circuits in external wiring. Not observing this may result in burning.
- Be sure that all cable connector screws are tightened to the torque specified in the relevant manuals. Incorrect tightening torque may result in malfunction.
- Do not allow metal clippings to enter either Option Board or Inverter when wiring or installing the unit.
- Follow the network configuration and wiring instructions provided in the DeviceNet Operation Manual (Cat. No. W267):
  - Wire the DeviceNet cables and connectors correctly. Incorrect wiring may result in burning.
  - Always connect a Terminating Resistor at the prescribed locations of the DeviceNet network to ensure the quality of the transmission path. Do not apply termination anywhere else.
- Be sure that the Option Board is mounted correctly. Improper mounting may result in malfunction.
- Disconnect the grounding cable when performing withstand-voltage tests. Not disconnecting the grounding cable may result in burning.

### 4 Configuration Precautions

-  **Caution** Failure to observe these precautions could lead to unexpected operation of the Option Board or the Inverter. Always read these precautions.

- Check the network related Inverter settings regarding DeviceNet node address and DeviceNet remote I/O allocation. Not doing so may result in unexpected operation.
- When replacing an Inverter be sure that all Inverter settings of the Inverter being replaced are restored to the replacement.
- Restoring parameters stored in the remote operator also restores the DeviceNet node address. Always check the node address and other network related Inverter settings after restore.

## 5 Application Precautions

 **WARNING** Before using the product under conditions which are not described in the manual or applying the product to nuclear control systems, railroad systems, aviation systems, vehicles, combustion systems, medical equipment, amusement machines, safety equipment, and other systems, machines, and equipment that may have a serious influence on lives and property if used improperly, consult your OMRON representative.

 **WARNING** It is extremely important that the Unit is used for its specified purpose and under the specified conditions, especially in applications that can directly or indirectly affect human life. You must consult your OMRON representative before using it in a system in the above-mentioned applications.

 **WARNING** Failure to observe these precautions could lead to serious or possibly fatal injury. Always read these precautions.

- Check any user program in the system that acts as a DeviceNet Master before actually running it. Not checking the program may result in unexpected operation.
- For safe operation clear the run command via DeviceNet as soon as a trip condition is detected.
- In the event the Inverter is in a Trip state, be sure to investigate the cause of this Trip state thoroughly before clearing the Trip. Not checking the cause may result in unexpected operation.

 **Caution** Failure to observe these precautions could lead to faulty operation of the Option Board or the Inverter, or could damage to either of the two. Always read these precautions.

- Check the Inverter settings for proper Inverter behaviour before actually operating the Inverter remotely via the DeviceNet network.
- Check the Inverter's EzSQ program and its interaction with the DeviceNet Master before actually running it on the Inverter. Not checking the program may result in unexpected operation.
- Confirm that no adverse effect will occur at the moment the DeviceNet Master stops communicating with the Inverter or at the moment the DeviceNet Master has not yet started communicating to the Inverter.
- Confirm that no adverse effect will occur in the Inverter before force-setting/force-resetting any bit in the system that acts as a DeviceNet Master.

## 6 Operating Environment Precautions

 **Caution** Do not operate the MX2-A□ Inverter with a mounted 3G3AX-MX2-DRT-E Option Board in the following locations (doing so may result in malfunction, electric shock or burning):

- Locations subject to direct sunlight
- Locations subject to temperatures or humidity outside the range specified in the specifications
- Locations subject to condensation as the result of severe changes in temperature
- Locations subject to corrosive or flammable gases
- Locations subject to dust (especially iron dust) or salts
- Locations subject to exposure to water, oil, or chemicals
- Locations subject to shock or vibration

 **Caution** Take appropriate and sufficient countermeasures when installing systems in the following locations (doing so may result in malfunction):

- Locations subject to static electricity or other forms of noise
- Locations subject to strong electromagnetic fields
- Locations subject to possible exposure to radioactivity
- Locations close to power supplies

 **Caution** The operating environment of the MX2-A□ Inverter with a mounted 3G3AX-MX2-DRT-E Option Board can have a large effect on the longevity and reliability of the system. Improper operating environments can lead to malfunction, failure, and other unforeseeable problems with the system. Make sure that the operating environment is within the specified conditions at installation and remains within the specified conditions during the life of the system.

## 7 Handling, Storage and Disposal

 **Caution** Failure to observe these precautions could lead to faulty operation of or damage to the Option Board. Always read these precautions.

- Before touching the Option Board or Inverter, be sure to first touch a grounded metallic object in order to discharge any static built-up. Not doing so may result in malfunction or damage.
- When transporting or storing the 3G3AX-MX2-DRT-E Option Board, keep the product within the specified storage temperature range.

 **Caution** Never dispose electrical components by incineration. Contact your state environmental agency for details on disposal of electrical components and packaging in your area.

## 8 Compliance with EC Directives

This product complies with EC Directives when mounted to an MX2-A□ Inverter with the grounding cable connected.



# SECTION 1

## Getting Started

### 1-1 Introduction

#### 1-1-1 Main Features

The 3G3AX-MX2-DRT-E allows controlling, monitoring and parameterization of an MX2-A□ Inverter via a DeviceNet network. The 3G3AX-MX2-DRT-E serves as a gateway that passes communicated register values from the DeviceNet network to the MX2-A□ Inverter and vice versa. The 3G3AX-MX2-DRT-E adheres to the DeviceNet / CIP AC Drive profile.

The following functions are available via DeviceNet communication by installing the 3G3AX-MX2-DRT-E:

##### Cyclic Data Exchange

The DeviceNet Master and 3G3AX-MX2-DRT-E can exchange data via a DeviceNet Remote I/O connection:

- Output data (from DeviceNet Master to 3G3AX-MX2-DRT-E):  
E.g. Run/stop, Reference frequency and Fault reset.
- Input data (from 3G3AX-MX2-DRT-E to DeviceNet Master):  
E.g. Inverter status, Output frequency and Output current, etc.

##### Inverter Parameter Access

The DeviceNet Master can read and write parameter data via the 3G3AX-MX2-DRT-E using the explicit message communication.

The inverter parameters are accessible in multiple ways:

- Access based on Function code
- Access based on the Modbus register address

Several AC Drive profile attributes can also be accessed using the explicit message mechanism.

##### Simplified Start-up

The 3G3AX-MX2-DRT-E can be set up easily, just by wiring the Unit, setting the DeviceNet node address (P192) and the default connection path (P046) and restarting the unit. The Unit's configuration is read automatically when the power is turned ON or after a reset. It is not necessary to make any settings with a special Programming Device.

##### Simplified Replacement

All parameters required by the 3G3AX-MX2-DRT-E are stored in the MX2-A□ Inverter. The 3G3AX-MX2-DRT-E can be replaced, requiring no re-configuration.

##### Automatic Baud Rate Recognition

The 3G3AX-MX2-DRT-E automatically detects the Master's communication baud rate, and no user configuration is required.

##### Note

If the DeviceNet Master Unit's baud rate changes, reset the Master Unit and be sure to turn OFF and ON or reset the 3G3AX-MX2-DRT-E and other connected Slave Units to detect the new baud rate.

## 1-1-2 Inverter Support

The 3G3AX-MX2-DRT-E Option Board supports the MX2-A□ Inverter with minimum revision of AAAA. An MX2-A□ Inverter that supports the 3G3AX-MX2-DRT-E Option Board can be recognised from the Inverter type label. Please check that your Inverter type label displays revision characters in the bottom right corner where the is displayed in this illustration.

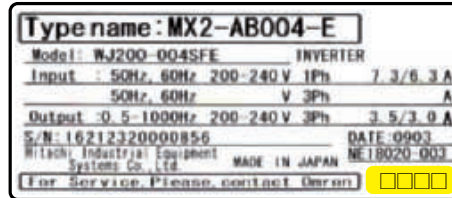

Please note if these characters are absent, your Inverter does not support the 3G3AX-MX2-DRT-E, so please contact your local OMRON representative.

## 1-1-3 Inverter Safety (ISO 13849-1)

An MX2-A□ Inverter provides a Gate Suppress function to perform a safe stop according to the EN60204-1, stop category 0. The 3G3AX-MX2-DRT-E Option Board has been designed not to interfere with this safety function.

**Note** The 3G3AX-MX2-DRT-E is not a safety device and does not implement any safety protocols.



## 1-2 Option Board Specifications

Table 1 Option Board Specification

Item		Specification
<b>Installation</b>	Unit type	MX2 Series Option Board
	Model	3G3AX-MX2-DRT-E
	Dimensions (W x H x D)	68 x 58 x 45 mm
	Weight	170g (typical)
<b>Environment</b>	Ambient operating temperature	-10 to 55°C (no icing or condensation)
	Ambient operating humidity	20 to 90%RH
	Ambient storage temperature	-20 to 65°C (no icing or condensation)
	Vibration resistance	5.9m/s <sup>2</sup> (0.6G) at 10...55Hz
	Dielectric strength	500 VAC (between isolated circuits)
	Conformance to EMC and Electrical safety standards	EN61800-3: 2004 (2004/108/EC) Second environment, Category C3
		EN61800-5-1: 2007 (2006/95/EC) SELV
Enclosure rating	IP 20	
<b>DeviceNet Interface</b>	Communications protocol	DeviceNet
	Certification	DeviceNet Conformance Tested
	DeviceNet Profile	AC Drive (0x02)
	Supported connections	Remote I/O: Master-Slave connection
		Poll
		Bit-Strobe
		COS
		Cyclic
Explicit Messages	Conform to DeviceNet specifications	
Communications power supply	11 to 25 VDC	
Unit device address range	MAC ID 0 to 63, set with inverter parameter P192	
Baud rates supported	125, 250 or 500 kbps. Automatically detecting baud rate of Master Unit	
<b>DeviceNet Configuration</b>	Default Connection path	Supported, set with inverter parameter P046
	Supported Assemblies	Basic Remote IO (Output assembly 20, Input assembly 70) Extended Speed IO (21, 71) Extended Speed and Torque Control (123, 173) Special IO (100, 150) Extended Control IO (101, 151) Extended Control IO and Multi function IO monitor (101, 153) Flexible Format (139, 159) Extended Speed and Acceleration Control (110, 111) In case the DeviceNet master is configured using user allocation, only the input / output pairs can be configured.
		EDS file

**Note 1** The derated- or ambient operating temperature of the MX2 Inverter takes precedence over that of the Option Board.

**Note 2** In case the 3G3AX-MX2-DRT-E is connected to the MX2-A□ Inverter, it is not supported to connect any external devices to the RS485 (Modbus) interface and the RJ45 port (Optional operator port) of the inverter.

The required EDS file for the option board depends on the model of the MX2-A□ inverter.

Table 2 Device List

MX2-A□ Model name	Name of EDS file	Product Code
MX2-AB001-E	3G3AX-MX2-DRT-AB001_A2001-E.eds	1880
MX2-A2001-E		
MX2-AB002-E	3G3AX-MX2-DRT-AB002_A2002-E.eds	1881
MX2-A2002-E		
MX2-AB004-E	3G3AX-MX2-DRT-AB004_A2004-E.eds	1882
MX2-A2004-E		
MX2-AB007-E	3G3AX-MX2-DRT-AB007_A2007-E.eds	1884
MX2-A2007-E		
MX2-AB015-E	3G3AX-MX2-DRT-AB015_A2015-E.eds	1886
MX2-A2015-E		
MX2-AB022-E	3G3AX-MX2-DRT-AB022_A2022-E.eds	1887
MX2-A2022-E		
MX2-A2037-E	3G3AX-MX2-DRT-A2037-E.eds	1889
MX2-A2055-E	3G3AX-MX2-DRT-A2055-E.eds	1891
MX2-A2075-E	3G3AX-MX2-DRT-A2075-E.eds	1892
MX2-A2110-E	3G3AX-MX2-DRT-A2110-E.eds	1893
MX2-A2150-E	3G3AX-MX2-DRT-A2150-E.eds	1894
MX2-A4004-E	3G3AX-MX2-DRT-A4004-E.eds	1902
MX2-A4007-E	3G3AX-MX2-DRT-A4007-E.eds	1904
MX2-A4015-E	3G3AX-MX2-DRT-A4015-E.eds	1906
MX2-A4022-E	3G3AX-MX2-DRT-A4022-E.eds	1907
MX2-A4030-E	3G3AX-MX2-DRT-A4030-E.eds	1908
MX2-A4040-E	3G3AX-MX2-DRT-A4040-E.eds	1910
MX2-A4055-E	3G3AX-MX2-DRT-A4055-E.eds	1911
MX2-A4075-E	3G3AX-MX2-DRT-A4075-E.eds	1912
MX2-A4110-E	3G3AX-MX2-DRT-A4110-E.eds	1913
MX2-A4150-E	3G3AX-MX2-DRT-A4150-E.eds	1914

## 1-3 Introduction to DeviceNet

### 1-3-1 Overview of DeviceNet

DeviceNet is a multi-bit, multi-vendor network that combines control and monitoring on a machine/line-control level and that conforms to DeviceNet open field network specifications. DeviceNet is a member of a family of networks that implements the Common Industrial Protocol (CIP) at its upper layers.

Two types of communications are supported to provide a single point of connection for both control and configuration:

1. Time-critical control remote I/O communications that automatically transfer between the Master Unit/CPU Unit and the remote Slave Units, and
2. Explicit message communications that read/write messages, control operation, or perform other functions to the Slave Units. Message communications are achieved by executing specific instructions from the program in the CPU Unit to which the Master Unit is mounted.

### **1-3-2 What is the AC Drive profile**

Within DeviceNet/CIP standard, multiple device profiles have been defined. Therefore the devices which adhere to a certain device profile are compatible and replaceable in a multi-vendor environment.

The AC Drive device profile (profile code 0x02) supplements the DeviceNet/CIP standard. It defines a unified behaviour and technique to access Inverter and drive device data. All drives supporting the AC Drive profile respond the same way to control instructions.



# SECTION 2

## Option Board Mounting and Installation

### 2-1 Orientation to Option Board Features

#### 2-1-1 Unpacking and Inspection

Take a few moments to unpack your new 3G3AX-MX2-DRT-E Option Board and perform these steps:

1. Look for any damage that may have occurred during transportation.
2. Verify the contents of the box:

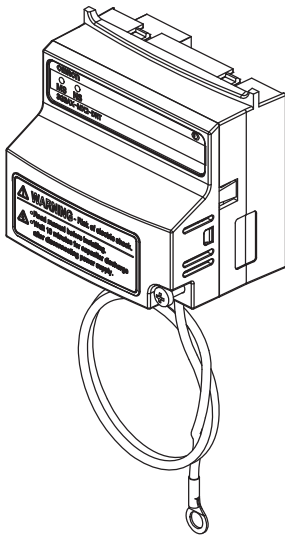

Option Board with Grounding Cable and DeviceNet connector

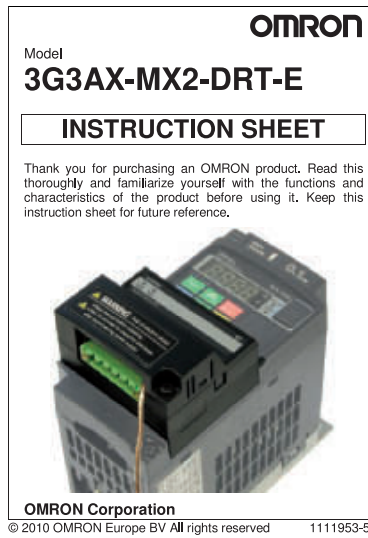

Instruction Sheet



Warning Labels

3. Inspect the markings on the Option Board. Make sure it matches the product part number you ordered.

### 2-1-2 Main Physical Features

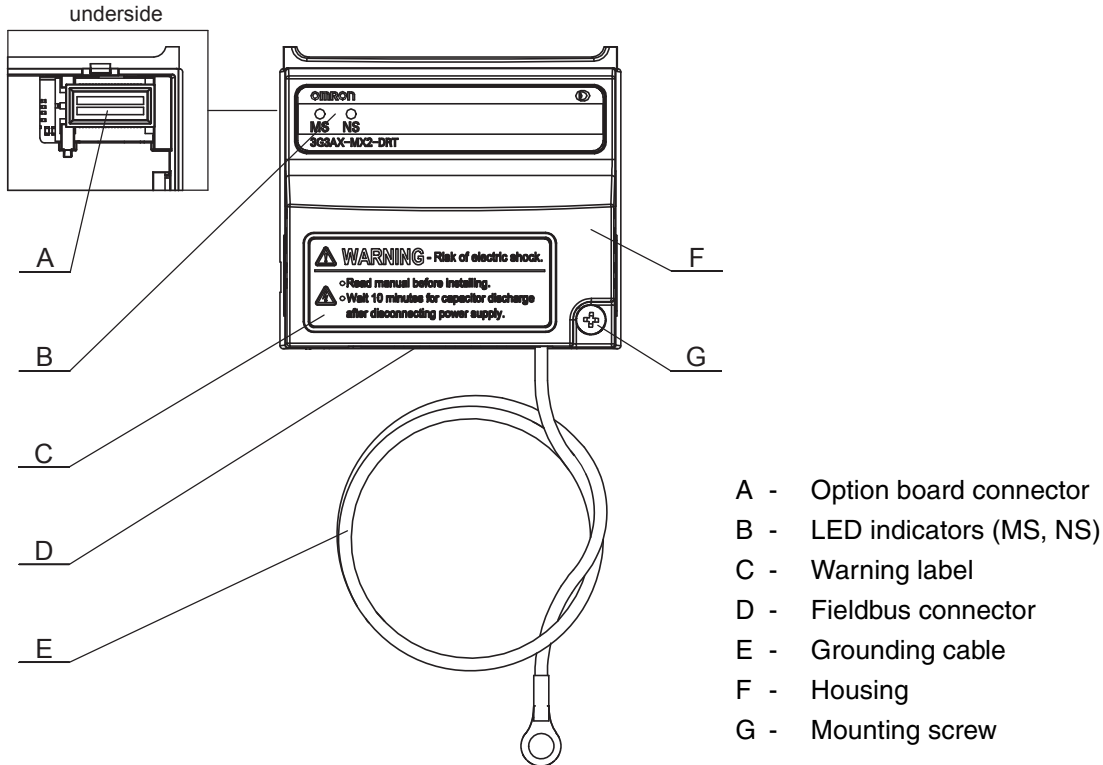

The LED indicators (B) allow easy diagnosis. An attached grounding cable (E) is sized to reach the ground terminals on all MX2-A□ Inverter models. A feature in the housing (F) will retain the mounting screw (G) when the Option Board is not mounted to the Inverter. The orientation of the Fieldbus connector (D) allows unstrained connection and removal of the DeviceNet connector. Please pay special attention to the Option Board connector: It must be properly connected with the Inverter when the Option Board is mounted.

### 2-1-3 LED Indicators

The LED indicators on the front indicate the operational mode and status of the Option Board and the network.

Table 3 LED Indicators

Indicator	Colour	Status	Meaning
MS (Module status)		Not lit	<ul style="list-style-type: none"> <li>Power is not supplied to the Option Board</li> <li>Option Board is being reset</li> </ul>
	Green	Lit	Normal operation
	Red	Lit	Unrecoverable fault: <ul style="list-style-type: none"> <li>Option Board hardware error</li> <li>Unsupported Inverter version</li> </ul>
		Flashing	Recoverable fault: <ul style="list-style-type: none"> <li>Network power is OFF</li> <li>Node address changed</li> <li>Illegal Flexible configuration</li> <li>Option Board parameters out of range or cannot be read</li> <li>Option Board detects consecutive communication errors</li> </ul>

Table 3 LED Indicators (continued)

Indicator	Colour	Status	Meaning
NS (Network status)		Not lit	<ul style="list-style-type: none"> <li>Power not supplied (check Module Status LED)</li> <li>Network power is OFF or DeviceNet connector unplugged</li> <li>Checking for node address duplication (intermediate state)</li> </ul>
	Green	Lit	Network is operating normally (communications established)
		Flashing	Network is operating normally, but communications have not been established.
	Red	Lit	Option Board detects network communication not possible due to Communications error: <ul style="list-style-type: none"> <li>Node address duplication</li> <li>Bus-off error</li> </ul>
Flashing		Option board detects communication lost. One or more Connections are in time-out state.	

**Note** Refer to section 5-1 for Troubleshooting using the LED indicators on page 33.

## 2-2 Basic System Description

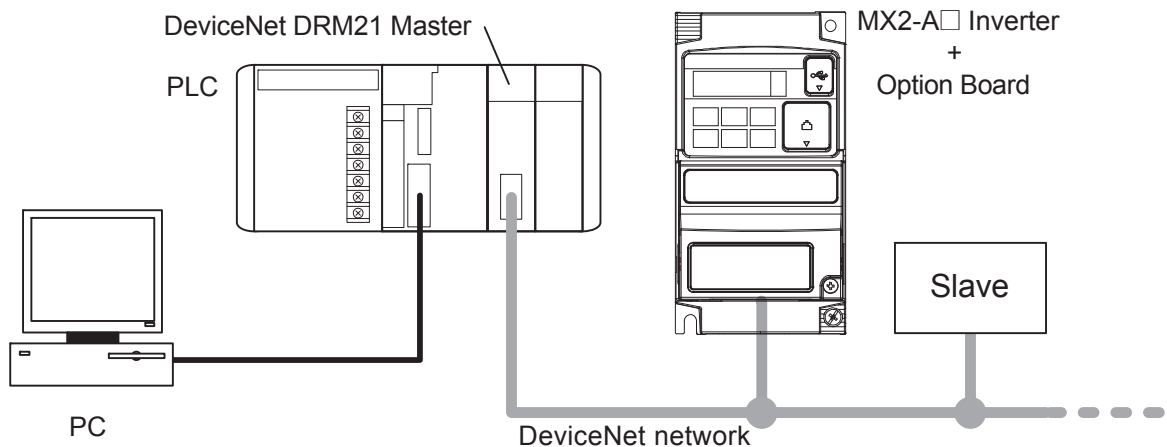

The Option Board connects to the Master via a DeviceNet network cable. Inverter I/O data is generally shared with the Master's I/O memory through the DeviceNet network. Every DeviceNet communication cycle, Inverter I/O data is collected by the Option Board and exchanged with the Master. The PC (personal computer) allows you to configure, monitor, program, diagnose and operate the system.

## 2-3 Step-by-Step Basic Installation

### 2-3-1 Option Board Mounting

**⚠ HIGH VOLTAGE**

Always switch OFF the mains power supply to the Inverter before removing any covers. Wait for the time specified on the Inverter front cover for the capacitors to discharge. Not doing so may result in electrical shock.

**Step 1** Loosen the screw of the option board cover, remove the cover and put the cover aside.

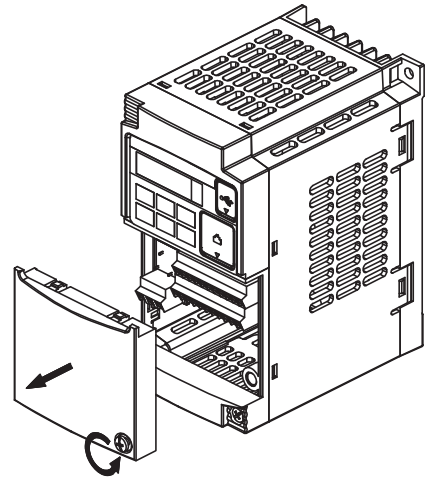

**Step 2** For Inverters up to 4.0 kW only: loosen the screws of the terminal block cover and remove the cover to enable access to the chassis ground terminal screws.

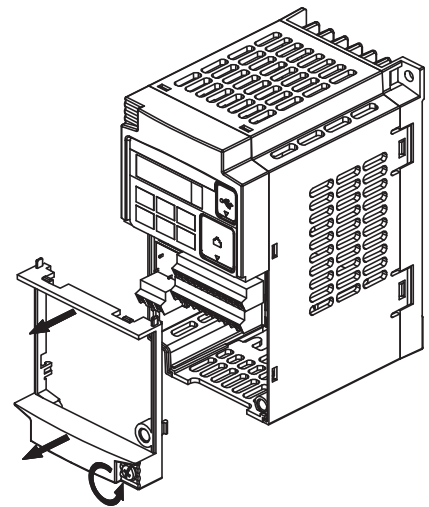

**Step 3** Secure the Option Board grounding cable to the MX2-A□ Inverter with a mounting screw.

1-phase 200 V 0.1 - 2.2 kW  
 3-phase 200 V 0.1 - 3.7 kW  
 3-phase 400 V 0.4 - 4.0 kW

3-phase 200 V 5.5 - 15 kW  
 3-phase 400 V 5.5 - 15 kW

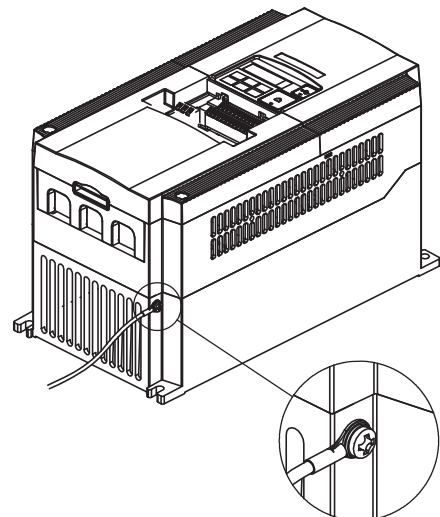
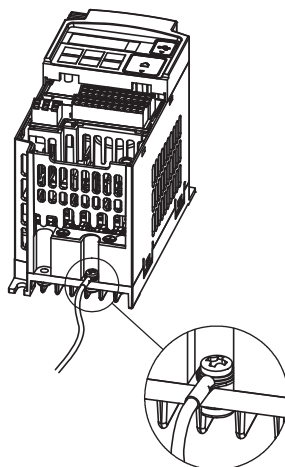



**Step 4** If removed in Step 2, mount the terminal cover again and tighten the screw(s).

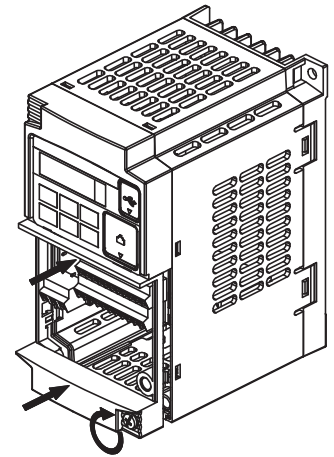

**Step 5** Push the Option Board into the previous location of the option board cover until it clicks into place

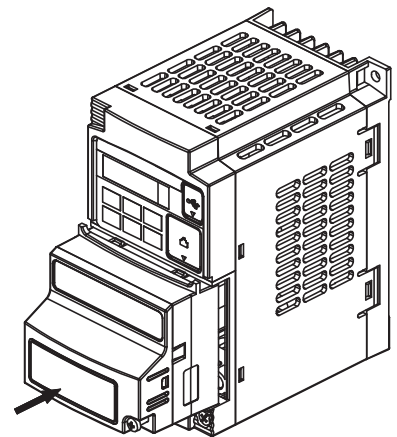

**Step 6** Press down on the indicated corner of the Option Board housing to ensure proper connection of the Option Board connector

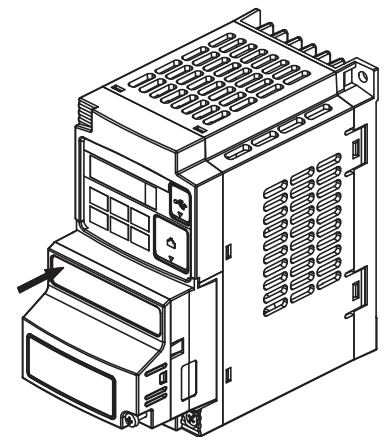

**Step 7** Check that there is no gap between the top edges of the Option Board and the Inverter casing.

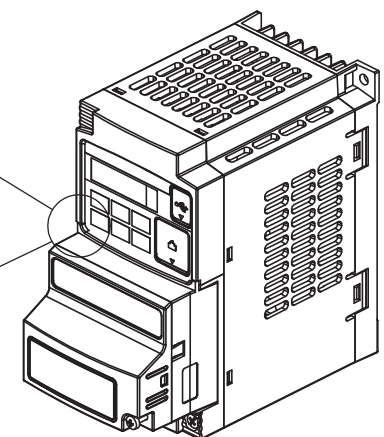
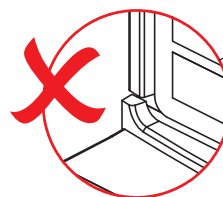
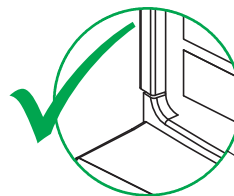

**Step 8** Secure the Option Board in place with the mounting screw (do not over-tighten).

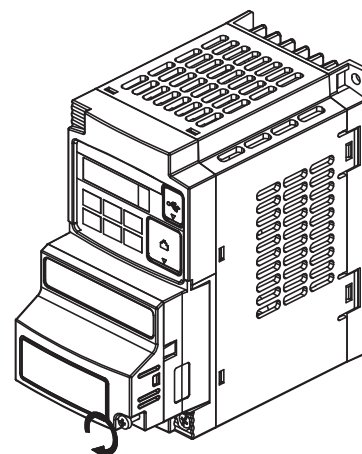

**Step 9** Select the right warning language from the warning label sheet and replace the English warning if appropriate.

**Note 1** Refer to section 2-1-3 in the MX2 User's Manual (Cat. No. I570) for operations related to assembly and disassembly of the MX2-A□ Inverter:

**Note 2** Some Inverter models do not include a screw for the grounding cable. Please supply the recommended screw, lock-washer and washer to attach the grounding cable.

Table 4 Ground cable screw selection

Inverter models	Grounding Cable Attachment Screw
3-phase 200 V 5.5 – 7.5 kW	M4 x 6
3-phase 400 V 5.5 – 7.5 kW	
3-phase 200 V 11 – 15 kW	M5 x 6
3-phase 400 V 11 – 15 kW	

**Note 3** Illustrations are only provided for one Inverter size. The instructions however are generic, and may be followed for all Inverter sizes. Make use of the MX2-A□ Inverter manual.

**⚠ HIGH VOLTAGE** Never operate the Inverter with the terminal block cover or backing plate removed.

**⚠ WARNING** Always connect the grounding cable to one of the ground terminals of the MX2-A□ Inverter. Failure to abide could lead to serious or possibly fatal injury.

**⚠ WARNING** Provide emergency stop circuits, interlock circuits, limit circuits and similar safety measures in external circuits (NOT in the Option Board). This ensures safety in the system if an abnormality occurs due to malfunction of the Option Board or another external factor affecting the Option Board operation. Not doing so may result in serious accidents.

**⚠ Caution** Never touch the heat sink during or just after operation; it can be very hot.

**⚠ Caution** Be sure that the Option Board is mounted correctly. Improper mounting may result in malfunction.

**⚠ Caution** Be sure that all cable connector screws are tightened to the torque specified in the relevant manuals. Incorrect tightening torque may result in malfunction.

## 2-3-2 Installation Environment Clearance

Please adhere to the requirements of section 2-3-2 in the MX2 User's manual (Cat. No. I570) on "Installation Environment clearance". In addition to this, provide sufficient clearance to allow connection and removal of the DeviceNet connector. No unnecessary strain should be placed on the DeviceNet cable or connector that could be transferred to the Option Board.

## 2-3-3 DeviceNet network connector

The Option board is supplied with a multi-drop DeviceNet connector with colour coded lines. Connect the DeviceNet network's communications cable to the DeviceNet communications connector. No termination is provided inside the Option Board.

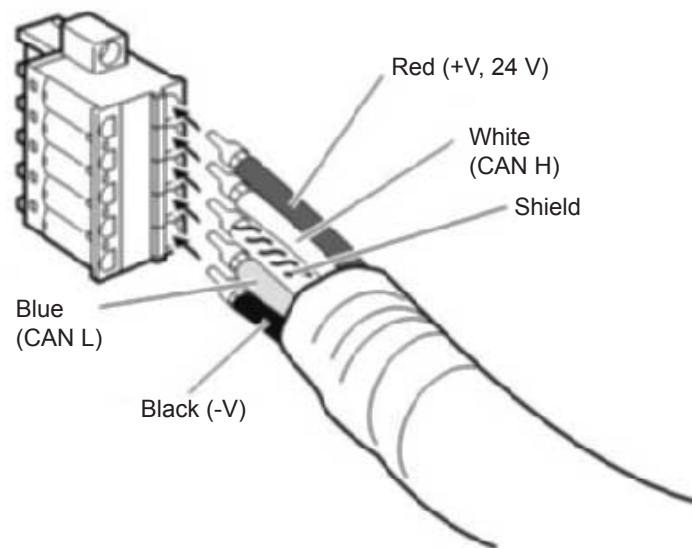

Table 5 DeviceNet connector signals

Colour	Signal	Description
Red	+V	Communications power supply (24VDC)
White	CAN H	Communications data lines (high)
-	Shield	Cable shielding
Blue	CAN L	Communications data lines (low)
Black	-V	Communications power supply (0VDC)

- Note 1** Make sure that there are 121-Ω terminators connected at both ends of the trunk line. Connect 121-Ω terminators if the wrong resistance is being used.
- Note 2** Connect cable shielding to the connectors on both ends of the cable.
- Note 3** Refer to Section 2-3 of DeviceNet Operation manual (Cat. No. W267) for details about cables and connectors.

**Caution** In a DeviceNet system, use DeviceNet cables that conform to the DeviceNet specifications.

### 2-3-4 Option Board Dimensions

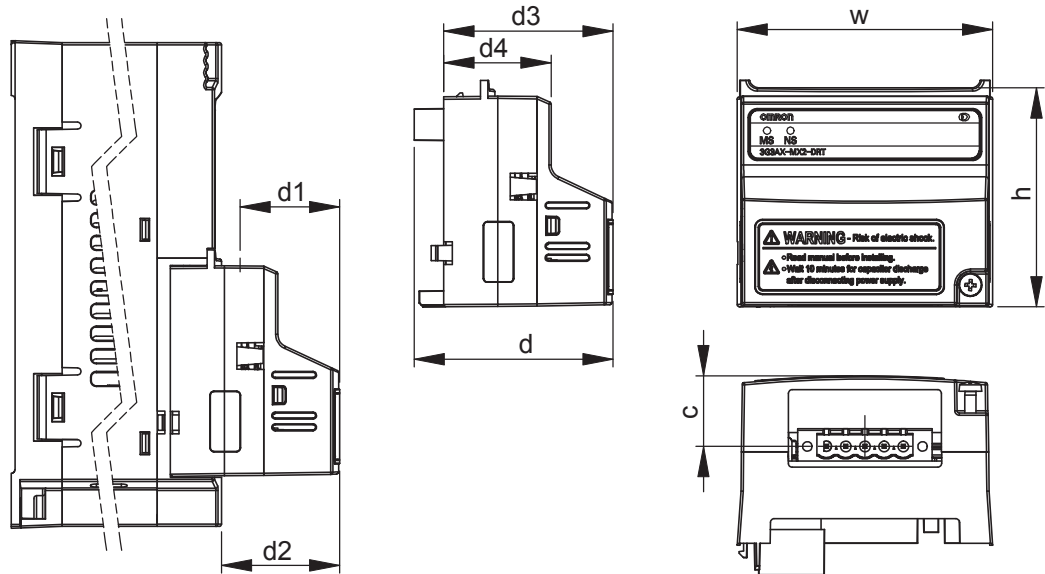

Table 6 Option Board Dimensions

Item	Dimension
h	57.9 mm
w	67.6 mm

Item	Dimension
c	18.7 mm
d	52.6 mm
d1 <sup>1</sup>	26.4 mm

Item	Dimension
d2	31.3 mm
d3	44.8 mm
d4	28.4 mm

1. Dimension d1 gives the increase in MX2-A□ Inverter dimension D when the Option Board is fitted. Please refer to section 2-3 of the MX2 User's manual (Cat. No. I570).

# SECTION 3

## Configuring Drive Parameters and Option Board

### 3-1 Installation of EDS files

For each of the MX2 Inverter models, a specific EDS file exists for the Option Board. The EDS files contain specific parameter data (default, ranges) depending on the model. Perform the following steps to install the EDS files prior to configure the network.

- Step 1** Download the EDS files named *3G3AX-MX2-DRT-□-E.eds* for the 3G3AX-MX2-DRT-E Option Board via the Omron website (<http://industrial.omron.eu>).
- Step 2** Install / add these EDS files to the DeviceNet Master Unit configuration program used to configure your DeviceNet master.

### 3-2 Configuring the Option Board

All Option Board parameters are stored in the MX2-A□ Inverter. This allows for easy replacement of the Option Board without the need to re-configure. After connecting the Option Board to an MX2-A□ Inverter for the first time however, proceed with the following steps:

- Step 3** Set the DeviceNet node number / MAC ID by configuring inverter parameter P192. Use either the Inverter keypad or any other method of configuring the inverter parameters. See note 1.

*Table 7 Configuration of Node Number*

Param	Description	Setting
P192	DeviceNet Node Address	0 to 63 (default: 63)

- Step 4** When using the automatic / fixed allocation mechanism of the DeviceNet Master Unit (see next section), choose the required Output and Input assembly pair using inverter parameter P046 Default Connection Path.

*Table 8 Default Connection Path*

P046 value	Description	Assembly nr (Hex)	
		Output	Input
0	Basic Speed IO	20	70
1	Extended Speed IO (default)	21	71
2	Extended Speed and Torque Control	123	173
3	Special IO	100	150
4	Extended Control IO	101	151
5	Extended Control IO and Multi Function IO Monitor	101	153
6	Flexible Format	139	159
7	Extended Speed and Acceleration Control	110	111

- Step 5** It is recommended to set C102 = 3 to prevent the Inverter reset input and Stop/reset button from interfering with Option Board during operation. Setting C102 to another value causes the Option Board to reset when a trip condition is cleared. See the MX2 User's manual (Cat. No. I570) for details on this parameter.

*Table 9 Configuration of Inverter Reset Mode Selection*

Param	Description	Setting
C102	Reset mode selection	Set to 3 "Resetting only trip" (recommended setting)

**Step 6** Inverter registers P044, P045 and P048 configure the DeviceNet network-related parameters. Adjust these to configure required action in case a fieldbus network IDLE mode behaviour and/or a fieldbus failure occurs.

Table 10 Configuration of DeviceNet Parameters

Param	Description	Setting
P044	Network Error Timer	Communication watchdog timer while running. <b>Note</b> additional to DeviceNet inactivity / watchdog timer. 0 to 9999 in 0.1 s unit. Set to 0 to disable.
P045	Action on Network Error	Set to 0 for inverter trip (Default) Set to 1 for deceleration and trip Set to 2 for no action Set to 3 for stop due to free-run Set to 4 for deceleration and stop
P048	Action on Network Idle Mode	Set to 0 for inverter trip (Default) Set to 1 for deceleration and trip Set to 2 for no action Set to 3 for stop due to free-run Set to 4 for deceleration and stop

**Step 7** Registers A001 and A002 are used by the Inverter to adjust the frequency source and control source. If the second motor parameter set is used, registers A201 and A202 also have to be set. Adjust these in accordance with the following table:

Table 11 Configuration of Source Selection Parameters

Param	Description	Setting
A001	Motor 1 Frequency Source	For option board as source: Set to 4 "Option Board input" for all assemblies except Flexible format (P046 is not 6) Set to 3 "Modbus network input" in case of Flexible format (P046 is 6)
A002	Motor 1 Run Command Source	

**Step 8** Registers P033, P036, C021, C022 and C026 are used by the Inverter to adjust some Inverter function sources. If required, adjust these in accordance with the following table:

Table 12 Configuration of Other Selection Parameter

Param	Description	Setting
P033	Torque Command Source	For option board as source: Set to 6 "Option Board input" for all assemblies except Flexible format (P046 is not 6) Set to 3 "Digital Operator input" for Flexible format (P046 is 6)
P036	Torque Bias Mode	For option board as source: Set to 5 "Option Board input" for all assemblies except Flexible format (P046 is not 6) Set to 3 "Digital Operator input" for Flexible format (P046 is 6)
C021	Output Terminal 11 Source	Set to 63 for option board as source
C022	Output Terminal 12 Source	Set to 63 for option board as source
C026	Alarm Relay Source	Set to 63 for option board as source (optional)

**Step 9** The Flexible format (assembly 139/159) gives you the freedom to select any Inverter Modbus register for Cyclic Data Exchange. Inverter registers P160 – P179 are used to configure and map the exchanged Modbus registers. Please refer to *APPENDIX F Flexible Format* on page 79 for more detail.

Table 13 Configuration of Flexible Mapping

Param	Description	Setting
P160	Output Register 1 contents	Modbus register mapped into flexible output word 1
P161	Output Register 2 contents	Modbus register mapped into flexible output word 2
P162	Output Register 3 contents	Modbus register mapped into flexible output word 3
P163	Output Register 4 contents	Modbus register mapped into flexible output word 4
P164	Output Register 5 contents	Modbus register mapped into flexible output word 5
P165	Output Register 6 contents	Modbus register mapped into flexible output word 6
P166	Output Register 7 contents	Modbus register mapped into flexible output word 7
P167	Output Register 8 contents	Modbus register mapped into flexible output word 8
P168	Output Register 9 contents	Modbus register mapped into flexible output word 9
P169	Output Register 10 contents	Modbus register mapped into flexible output word 10
P170	Input Register 1 contents	Modbus register mapped into flexible input word 1
P171	Input Register 2 contents	Modbus register mapped into flexible input word 2
P172	Input Register 3 contents	Modbus register mapped into flexible input word 3
P173	Input Register 4 contents	Modbus register mapped into flexible input word 4
P174	Input Register 5 contents	Modbus register mapped into flexible input word 5
P175	Input Register 6 contents	Modbus register mapped into flexible input word 6
P176	Input Register 7 contents	Modbus register mapped into flexible input word 7
P177	Input Register 8 contents	Modbus register mapped into flexible input word 8
P178	Input Register 9 contents	Modbus register mapped into flexible input word 9
P179	Input Register 10 contents	Modbus register mapped into flexible input word 10

**Step 10** Restart the MX2-A□ Inverter for the changes to take effect. See note 1 and 2.

**Note 1** Alternative ways for configuring inverter parameters and resetting the inverter are use the OMRON CX-Drive tool, use CX-Integrator with the unit’s EDS file (see *SECTION 4 Operations and Monitoring* on page 21), or use Explicit messages to access the parameters directly (refer to *APPENDIX E DeviceNet Explicit Messages* on page 71).

**Note 2** When restarting the MX2-A□ Inverter, wait for the Inverter power indicator to go out before switching on again. Note the time to wait may vary depending on the Inverter model.

**Note 3** Some DeviceNet Master Units in market may send Idle messages during specific events (start-up, PLC program mode, etc). In this case, consider to put Action to Network Idle Mode (P048) to value 2 (no action).

 **Caution** Check the network related Inverter settings regarding DeviceNet node address and other settings. Not doing so may result in unexpected operation.

The EDS file contains the access data for most of the Inverter's parameters. This enables DeviceNet configurators such as CX-Integrator to configure the Inverter.

The defaults of the parameters have been selected specifically for the Option Board and not necessarily the same as the Inverter parameter's default value.

Please note that the write access of the Inverter parameters may depend on the Inverter mode. Also make sure the Inverter is not in trip state before downloading the parameters.

 **WARNING** During the parameter initialisation (Inverter parameter b180), operating the Inverter is not prevented automatically and doing so may lead to unpredicted behaviour.

Be sure to not operate the Inverter and do not write any Inverter parameter during the parameter initialisation by Option Board or any other interface.

## 3-3 Configuring the Network

The slaves will be allocated data in the I/O Memory of the Master Unit or CPU Unit the Master Unit is mounted to. They are allocated using one of the following methods:

1. Fixed allocations
2. User-set allocations

For details about configuring the OMRON CJ1W-DRM21 and CS1W-DRM21 Master Unit's using CX-Integrator as configurator software, refer to DeviceNet Unit Operation Manual (Cat. No. W380).

### Fixed Allocation Steps

**Step 1** Turn ON the communications, inverter(s), and Master Unit or PLC power supplies.

**Step 2** Confirm the Option Board's node number (inverter parameter P192) and Default Connection Path (inverter parameter P046) are set properly. See explanation in previous section.

**Step 3** Perform the Fixed allocation sequence as defined for the Master Unit.

**Step 4** Once the network is re-started with the new settings, check that the Option Board LED indicators indicate proper operation: If everything is correctly configured, both the MS (Module Status) LED and the NS (Network Status) LED will be Green. Please refer to section 5-1 *Troubleshooting Using the LED Indicators* for troubleshooting any configuration errors if the LED indicators are displaying a different pattern.

**Tip** In case of any errors during configuring the network, please refer to *SECTION 5 Troubleshooting and Maintenance*.



For the fixed allocations, the configuration can be done without the DeviceNet configurator. The output and input data of the slaves are allocated strictly in order of node address in the areas. The Master Unit will check the Default connection path of the actual Slave to select which assemblies will be used for the configuration.

**User-set Allocation Steps** The following steps are based on configuration of the OMRON CJ1W-DRM21 Master Unit using CX-Integrator tool.

- Step 1** Connect CX-Integrator to the network through a serial line or other interface.
- Step 2** Turn ON the communications, inverter(s), and Master Unit or PLC power supplies.
- Step 3** Open the Configurator and perform the User-set allocation sequence as defined for the Master Unit.
- Step 4** Create network topology by either
- offline operation adding Master Unit and Slaves or
  - uploading connected network.

Be sure to match the project's Slave node numbers with the actual numbers of the Unit's (as set with inverter parameter P192).

- Step 5** In the Master Unit's Edit Device Parameter window (General tab), register the Device List for the connected Devices.
- Step 6** Use the Advanced setting for the Slave to select the connection and assemblies required. See note.

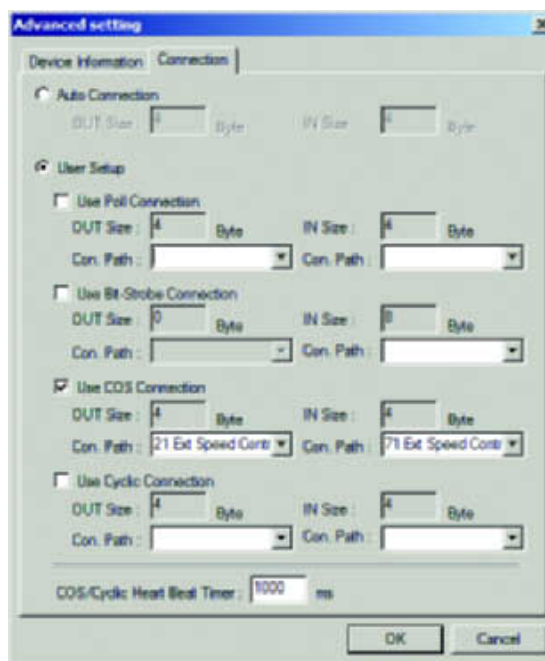

- Step 7** Go to the I/O allocation (IN/OUT) tabs to allocate the IO assemblies of the Slaves to PLC memory.
- Step 8** Save and download the configuration to your DeviceNet Master Unit.
- Step 9** Once the network is re-started with the new settings, check that the Option Board LED indicators indicate proper operation: If everything is correctly configured, both the MS (Module Status) LED and the NS (Network Status) LED will be Green. Please refer to section 5-1 *Troubleshooting Using the LED Indicators* for troubleshooting any configuration errors if the LED indicators are displaying a different pattern.

- Note 1** For a particular connection type (Poll, COS, Cyclic), only one of the pre-defined pairs as listed for the Default Connection Path (P046) can be configured. Please note in case a non-matching pair is selected, no error is generated. For either the input or output assembly, the matching pair will be configured.
- Note 2** Third party masters may require to set the inverter parameter P046 Default Connection Path corresponding to the User-set selection.
- Note 3** When using only COS or Cyclic connection, be sure to put the Network Error Timer P044 in the Inverter higher than the COS/Cyclic Heart beat timer.
- Tip** In case of any errors during configuring the network, please refer to *SECTION 5 Troubleshooting and Maintenance*.

For the user-set allocation, the DeviceNet configurator is used. The output and input data assemblies of the slaves can be allocated freely to the Master Units IO blocks. Also specific connection variants (Poll, Bit-Strobe, COS, Cyclic) can be selected based on the settings in the EDS file.

# SECTION 4

## Operations and Monitoring

This section provides some common usage examples to help you get started.

### 4-1 Setting up inverter

Unless otherwise specified, all usage examples make use of the Extended Speed IO format as the default connection path (Refer to section 3-1 *Installation of EDS files, Step 2*). Prepare the Inverter and Option Board before starting with the usage examples:

- Step 1** Initialize the Inverter mode to Std. IM by first setting b171 = 1 and then b180 = 1 (Refer to MX2 User's manual (Cat. No. I570) section 3-6-24).
- Step 2** Set the Inverter rating to CT (constant torque) by setting b049 = 0 (Refer to the MX2 User's manual section 3-2-5).
- Step 3** Configure the Option Board and Network as explained in sections 3-1 *Installation of EDS files* and 3-2 *Configuring the Option Board* with Extended Speed IO (Output assembly 21, Input assembly 71). There are two options:
  - When using Fixed allocation method of configuring the master, select P046 = 1.
  - When using User-set allocation, select the two Extended Speed IO assemblies.

If you configured everything correctly, your output and input I/O words should contain the following data:

Table 14 Extended Speed I/O Output Words

Word	Bit Allocation							
	7	6	5	4	3	2	1	0
	15	14	13	12	11	10	9	8
<b>Instance ID 21: Extended Speed Control Output</b>								
n	-	REF	CTR	-	-	RST	REV	FWD
	-	-	-	-	-	-	-	-
n + 1	Rotational Speed Reference (default [0.01 Hz])							
	Rotational Speed Reference							

Bit	Name	Description
FWD	Forward/Stop	0: Stop 1: Forward
REV	Reverse/Stop	0: Stop 1: Reverse
RST	Fault Reset	Reset Fault/Trip condition on transition from 0 to 1
CTR	NetCtrl	Run command selection. 0: Setting of A002 1: Network controlled
REF	NetRef	Speed reference selection. 0: Setting of A001 1: Network controlled

Table 15 Extended Speed I/O Input Words

Word	Bit Allocation							
	7	6	5	4	3	2	1	0
	15	14	13	12	11	10	9	8
<b>Instance ID 71: Extended Speed Control Input</b>								
n	ARF	RFN	CFN	RDY	DRR	DFR	WR	FLT
	Drive Status (see below)							
n + 1	Rotational Speed Monitor (default [0.01 Hz])							
	Rotational Speed Monitor							

Bit	Name	Description
FLT	Fault	0: Normal 1: Fault/Trip
WR	Warning	0: Normal 1: Warning
DFR	During forward run	0: Stop/reverse 1: During forward run
DRR	During reverse run	0: Stop/forward 1: During reverse run
RDY	Inverter ready	0: Inverter not ready 1: Inverter ready
CFN	Ctrl from Net	Run command input selection 0: Local 1: DeviceNet reference
RFN	Ref from Net	Speed reference input selection 0: Local 1: DeviceNet reference
ARF	At reference	0: Accel/decel phase 1: At reference

Drive Status	
Value	Description
1	Startup
2	Not ready
3	Ready
4	Enabled
5	Stopping
6	Fault/Trip Stop
7	Faulted/Tripped

**Caution** Check the Inverter settings for proper Inverter behaviour before actually operating the Inverter remotely via the network.

The product will be used to control an adjustable speed drive connected to high voltage sources and rotating machinery that is inherently dangerous if not operated safely. Interlock all energy sources, hazardous locations, and guards in order to restrict the exposure of personnel to hazards. The adjustable speed drive may start the motor without warning.

Signs on the equipment installation must be posted to this effect. A familiarity with auto-restart settings is a requirement when controlling adjustable speed drives. Failure of external or ancillary components may cause intermittent system operation, i.e., the system may start the motor without warning or may not stop on command. Improperly designed or improperly installed system interlocks and permissions may render a motor unable to start or stop on command.

## 4-2 Operating the Motor

### 4-2-1 Starting the Motor

**Step 1** Set A001 = 4 and A002 = 4 so that the Inverter can be controlled using the DeviceNet Option Board.

**Note** The net control (CTR) and net reference (REF) override bits in the 1<sup>st</sup> output word can be used to override A001 and A002. When these bits are set, it has the same effect as temporarily setting A001 = 4 and A002 = 4. Clearing these bits removes the override, and the Inverter sources are once again determined by these registers. Please note in case the inverter has version AAAA, override is not supported for A002 = 2.

**Step 2** Set F002 and F003 for adjusting the acceleration and deceleration time of the motor. Refer to MX2 User's manual (Cat. No. I570) section B-4.

**Step 3** Set the Rotation Speed Reference (see Appendix B) of the Inverter in the 2<sup>nd</sup> I/O output word to 10.00 Hz.

**Step 4** Set the FWD bit to put the Inverter in run mode. The RUN indicator on the Inverter should light up at this point. If this is not the case, check your source selection (please refer to section 3-2 step 5).

The motor accelerates until it reaches the desired frequency. Notice that the ARF bit is set once the inverter has reached the desired Rotation Speed Reference.

### 4-2-2 Changing Direction

**Step 5** Clear the FWD bit and set the REV bit.

The motor decelerates stops and then accelerates in the opposite direction. ARF bit clears as soon as the Rotation Speed Reference is changed. Once the new Rotation Speed Reference is reached, ARF bit is set again.

### 4-2-3 Stopping the Motor – Decelerated stop

**Step 6** Clear the run bits (FWD or REV) to bring the motor to a controlled (decelerated) stop.

The motor decelerates, and comes to a stop. ARF bit clears as soon as the run bit is cleared.

Before continuing set Rotation Speed Reference to 0 Hz.

**Note** The motor can also be brought to a stop by setting Rotation Speed Reference to 0 Hz and leaving the run bits set. The Inverter will however stay in run mode once the motor has reached 0 Hz.

## 4-2-4 Stopping the Motor – Free-running

An alternative to Clear the run bits (FWD or REV) to bring the motor to a controlled (decelerated) stop of step 6 is a free-run stop. The Inverter stops controlling the motor, and the motor coasts to a stop. Set C001 = 11 (FRS: free-run stop) to assign intelligent input terminal 1 as free-run stop enable. Restart the Inverter or reset the Option Board for the new settings to take effect. Set the terminal input 1 to ON to enable free-run stop. During a free-run stop, Rotation Speed Monitor immediately drops to 0 and ARF bit is cleared.

## 4-2-5 Changing Speed Reference and Speed Monitor Scaling

Rotational Speed Reference and Rotational Speed Monitor are word registers. The scaling of these values depend on the inverter's Motor poles setting P049:

1. In case P049 has non-zero value, the Unit is RPM.
2. In case P049 is set to zero, the Unit depends on the inverter mode. If the inverter is in High Frequency (HF) mode, the Unit is 0.1 Hz. The unit will be 0.01 Hz in other modes.

For the second option (Unit is either 0.1 Hz or 0.01 Hz), the maximum frequency which can be set is 400.00 Hz. Please refer to MX2 User's manual (Cat. No. I570) for instructions about inverter modes and parameter P049.

## 4-3 Overriding Inverter inputs

By using the Option Boards input override functionality, the Inverter Intelligent Terminal Functions can be controlled from the network.

The following example explains how to make use of the Option Board to override the input function Free Run Stop (FRS) using the IO data.

- Step 1** Configure the Option Board and Network as explained in sections 3-1 *Installation of EDS files* on page 15 and 3-2 *Configuring the Option Board* on page 15 with Extended Control IO and Multi-function IO monitor (Output assembly 101, Input assembly 151). There are two options:
- When using Fixed allocation method of configuring the Master, select P046 = 4.
  - When using User-set allocation, select the Extended Control IO and Multi-function IO monitor assemblies.
- Step 2** Set C003 = 11 (FRS: Free Run Stop) to assign intelligent input terminal 3.
- Step 3** The output words of assembly 101 contain the CI3 bit (see table 16), which overrides input terminal 3. Set this bit to enable the free run stop.

Please note that as an alternative to override inputs using this assembly with bits CI3 to CI7, also the explicit message writing the Discrete Input Point Object (0x08) can be used. Please refer to *APPENDIX B Assembly Specification* on page 43 and *APPENDIX E DeviceNet Explicit Messages* on page 71).

## 4-4 Controlling Inverter Torque

In addition to Speed control, the MX2-A□ Inverter allows direct control of the motor torque.

-  **Caution** Before following this example, disconnect your motor from any load to prevent injury or damage to property.

The following example explains how to make use of the Option Board to control the motor torque:

**Step 1** Configure the Option Board and Network as explained in sections 3-1 *Installation of EDS files* and 3-2 *Configuring the Option Board* with Control IO and Multi function IO monitor (Output assembly 101, Input assembly 151). There are two options:

- When using Fixed allocation method of configuring the master, select P046 = 4.
- When using User-set allocation, select the two Extended Control IO and Multi-function IO monitor assemblies.

**Step 2** Set C003 = 52 (ATR: permission of torque command input) to assign intelligent input terminal 3 as torque enable. See also section 4-3 *Overriding Inverter inputs*

**Step 3** Set parameter A044=3 to enable Sensorless Vector Control (SLV).

**Step 4** Set parameter P033=6 to assign Torque command input selection to Option Board.

**Step 5** Restart the Inverter or reset the Option Board for the new settings to take effect.

**Note** The Inverter will only allow setting of torque related registers if it is configured to operate with CT rating in Std. IM mode.

Your input and output process areas should now have the following layout:

Table 16 Extended Speed Torque I/O Output Words

Word	Bit Allocation							
	7	6	5	4	3	2	1	0
	15	14	13	12	11	10	9	8
<b>Instance ID 123: Extended Speed and Torque Control Output</b>								
n	-	CI7	CTR	CI5	CI4	CI3	REV	FWD
	CO2	CO1	CR	-	-	-	RST	FFL
n + 1	Rotational Speed Reference (default [0.01 Hz])							
	Rotational Speed Reference							
n + 2	Torque Reference [1 %]							
	Torque Reference							
n + 3	Torque Compensation Bias [1 %]							
	Torque Compensation Bias							

Bit	Name	Description
FWD	Forward/Stop	0: Stop 1: Forward
REV	Reverse/Stop	0: Stop 1: Reverse
RST	Fault Reset	Reset Fault/Trip condition on transition from 0 to 1
FFL	Force Fault	Force external fault/trip from network
CI3 to CI7	Control/Override Input	0: Reset 1: Set override for Multi Function input 3 to 7.
CO1, CO2, CR	Set (Relay) Output	0: Reset 1: Set Multi Function 1 to 2 or Relay Output (CR).

Table 17 Extended Speed Torque I/O Input Words

Word	Bit Allocation							
	7	6	5	4	3	2	1	0
	15	14	13	12	11	10	9	8
<b>Instance ID 71: Extended Speed Control Input</b>								
n	FLT	WR	RDY	ARF	-	DRR	DZS	DFR
	-	-	MO2	MO1	MR	CFN	-	-
n + 1	Rotational Speed Monitor (default [0.01 Hz])							
	Rotational Speed Monitor							
n + 2	Torque actual [1 %]							
	Torque actual							
n + 3	Output current monitor [0.1 A]							
	Output current monitor							
n + 4	-	MI7	MI6	MI5	MI4	MI3	MI2	MI1
	-	-	-	-	-	-	-	-

Bit	Name	Description
DFR	During forward run	0: Stop/reverse 1: During forward run
DZS	During zero speed	0: Non-zero speed 1: During zero speed
DRR	During reverse run	0: Stop/forward 1: During reverse run
ARF	At reference	0: Accel/decel phase 1: At reference
RDY	Inverter ready	0: Inverter not ready 1: Inverter ready
WR	Warning	0: Normal 1: Warning
FLT	Fault	0: Normal 1: Fault/Trip
CFN	Control from net	Run command input selection (0: local, 1: DeviceNet)
MO1, MO2, MR	Monitor (Relay) outputs	0: OFF 1: ON

**Step 6** Set the maximum allowable output frequency in torque mode by configuring P039 and P040 for the forward- and reverse run directions. Be careful to select safe limits for your test setup.

- Step 7** Set the Rotation Speed Reference (see *APPENDIX B Assembly Specification* on page 43) of the Inverter in the 2<sup>nd</sup> I/O output word to 10.00 Hz.
- Step 8** Set the Torque Reference of the Inverter in the 3<sup>rd</sup> I/O output word to 20%.
- Step 9** Set the FWD bit to put the Inverter in run mode. The motor will accelerate to a constant forward output frequency.
- Step 10** Override the input terminal 3 (CI3) to enable torque command input.  
The motor either accelerates or decelerates depending on the load. The output frequency is limited by the P039 setting. The output torque is given by d012.
- Step 11** To change the torque command direction, clear the FWD bit and set the REV bit.  
The motor decelerates and accelerates in the opposite direction. The output frequency is limited by the P040 setting.
- Note** As an alternative for the overriding of input terminal 3 from the network at step 10, also the physical input terminal can be used.

## **4-5 Faults and Trips**

### **4-5-1 External Trip**

You may want to trip the Inverter from your PLC program. Not all assemblies support setting the external trip by using a bit in IO Data. Basically there are two options:

- Select an assembly which support this trip set in the output data.
- Using explicit message to set the Force Fault/Trip attribute in the Control Supervisor Object ( Class 29 Hex, Instance 01 Hex, Attribute 11 Hex).

The two Extended Control IO assemblies (Output 101, Input 151) contains the FFL (Force Fault/Trip) bit and can be used for this feature.

- Step 1** Follow the instructions sections *3-1 Installation of EDS files* and *3-2 Configuring the Option Board* to configure the assemblies.
- Step 2** Set bit 8 (FFL) of the first word of the output data to trip the Inverter.  
The alternative is to use the explicit message mechanism to generate the external trip. Please refer to *APPENDIX E DeviceNet Explicit Messages* example 3 for a description how to do this.

### **4-5-2 Clearing a Trip**

When the inverter trips due to a fault condition first analyse the trip cause as explained in section *5-1 Troubleshooting Using the LED Indicators* on page 33 or section *5-3 Maintenance and Inspection* on page 38.

Notice that the FLT bit is set (present in all output assemblies) when the Inverter trips.



**WARNING**

In the event the Inverter is in a Trip state, be sure to investigate the cause of this Trip state thoroughly before clearing the Trip. Not checking the cause may result in unexpected operation.

- Step 1** Please clear the FWD and REV bits in your PLC program when a rising edge is detected on FLT.
- Step 2** Set the RST bit of the output assembly to clear the trip.

**⚠ WARNING** Always clear the run bits FWD and REV in your PLC program on the rising edge of the FLT bit. Not doing so may result in the motor starting unexpectedly when the trip is cleared via DeviceNet or the „Stop/reset“ button on the Inverter

## 4-6 Accessing Parameters

DeviceNet explicit messages sent from the Master Unit to the 3G3AX-MX2-DRT-E Unit can be used to access any parameter from the Unit or the MX2-A□ Inverter. Please refer to the *APPENDIX E DeviceNet Explicit Messages* on page 71 for details and examples.

Refer to the DeviceNet Master Units Operation manual (Cat. No. W380) for details on how to send the explicit messages to the 3G3AX-MX2-DRT-E. Below are examples for usage of the OMRON CJ1W-DRM21 Master Unit with the FINS Explicit Message Send command (2801).

### 4-6-1 Accessing General (AC Drive Profile) Objects

Reading the value of MX2-A□ inverter input terminal [4].

Command:

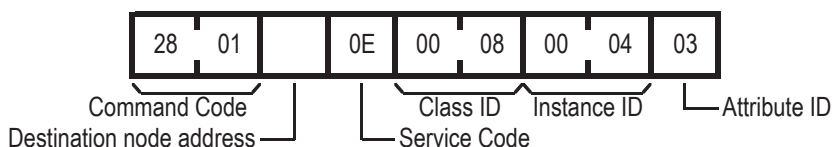

Response:

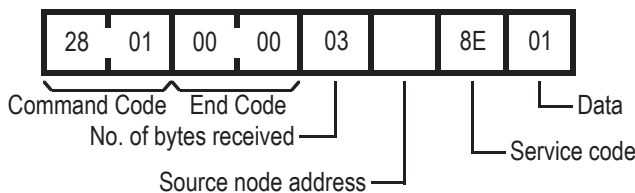

The value of input terminal [4] is ON.

### 4-6-2 Accessing Inverter parameter using Function Code Object

Writing the value of the acceleration time (F002) to 3.00 seconds (012C Hex). The parameter F002 corresponds to address 5002 (138A Hex). Please note the swapping of the data following CIP data type encoding.

Command:

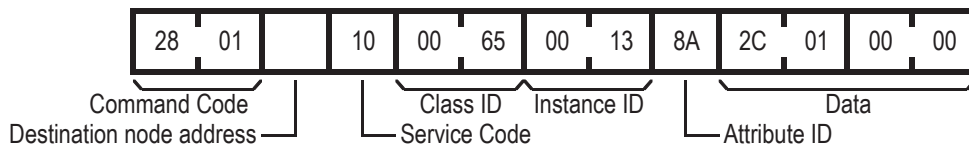

Response:

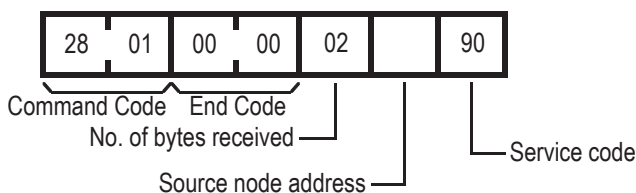



## 4-7 Flexible Format

The Flexible format lets you operate the Inverter using the Modbus registers directly. Parameters P160 to P169 and P170 to P179 can be used to map Modbus registers into the cyclically exchanged IO data. User parameters P160 to P169 configure the output data words where parameters P170 to P179 configure the input data words.

Please refer to the *APPENDIX F Flexible Format* on page 79 for details on the flexible mode.

### 4-7-1 Typical Configuration

- Step 1** Configure the Option Board and Network as explained in sections 3-1 *Installation of EDS files* and 3-2 *Configuring the Option Board*.
- Step 2** Set parameters P160 to 1F01h to map coil data 0 as the first output word.
- Step 3** Set parameters P161 and P162 to 0001h and 0002h to map the Modbus frequency reference (F001) as the 2<sup>nd</sup> and 3<sup>rd</sup> output words.
- Step 4** Set parameter P170 to 0005h to map Inverter status C as the first input word.
- Step 5** Set parameter P171 to 1E01h to map coil data 1 (coil no 0010h to 001Fh) into the second input word.
- Step 6** Set parameters P172 and P173 to 1001h and 1002h to map the Modbus frequency monitor (d001) as the third and fourth input word.
- Step 7** Restart the Inverter or reset the Option Board for the new settings to take effect.

If you configured everything correctly, your output and input words should have the following mapping:



Table 21 Flex Mode Input Area with Motor Running Forward

Word offset	+0	+1	+2	+3	+4	+5	+6	+7	+8	+9
Register	Invstat C	Coil data 1	d001 (1001h/1002h)		-	-	-	-	-	-
Value	dec	3	26	+1000		0	0	0	0	0
	hex	0003	001A	0000	03E8	0000	0000	0000	0000	0000

Bit	15	14	13	12	11	10	9	8	7	6	5	4	3	2	1	0
Name	ONT	RNT	TRQ	UV	-	OTQ	FA3	AL	OD	OL	FA2	FA1	RUN	-	Rdy	Dir
Value	0	0	0	0	0	0	0	0	0	0	0	1	1	0	1	0

- Step 11** Set Dir to reverse the direction of the motor. The motor decelerates, stops and then accelerates in the opposite direction. The FA1 bit clears as soon as the reference frequency is changed. Once the new reference frequency is reached, the FA1 bit is once again set.
- Step 12** Clear the Opr bit to stop the motor. The motor decelerates and comes to a halt.

### 4-7-3 Faults and Trips

User trips can be generated by setting the EXT bit in coil data 0. You must always immediately clear the Opr bit in your PLC program when the Unit indicates it is in Trip status (for example when AL bit is set ON). If the Opr bit is set when the trip condition is cleared, the Inverter will immediately start running!

**⚠ WARNING** Always clear the Opr bit in your PLC program when the AL bit is set ON by the Inverter. Not doing so may result in the motor starting unexpectedly when the trip is cleared.

Set and clear the RS bit in coil data 0 to clear a trip.

**⚠ WARNING** Always clear the RS bit after setting it. Not doing so will result in new trip conditions automatically being cleared.

## 4-8 Limitations Caused by Inverter Mode and Rating Selection

The Inverter mode and rating selection directly affects several aspects of the Option Board usage. Refer to the MX2 User's manual section 3-6-24. The following table lists the most common consequences of the various Inverter modes and ratings:

Table 22 Limitations Caused by Inverter Mode and Rating Selection

Inverter Mode and Rating	Standard Induction Motor		High Frequency	Permanent Magnet
	Constant Torque	Variable Torque		
<b>d060</b>	<b>0 (1-C)</b>	<b>1 (1-v)</b>	<b>2 (H-1)</b>	<b>3 (P)</b>
Rotational speed scaling	0.01 Hz		0.1 Hz	0.01 Hz
Torque-related registers	Available	Not available (see note 1)		

**Note 1** The Inverter will trip due to a cyclic mapping fault if you use torque-related registers in the process area when not available.

## 4-9 Monitoring additional Inverter status using COS

Typically the default DeviceNet Poll connection is used for controlling and monitoring the main functions of the Inverter. For specific monitoring of Inverter states, a second connection Change of State (COS) can be added. We will use the Flexible format for this connection.

The following steps are based on configuration of the OMRON CJ1W-DRM21 Master Unit using CX-Integrator tool. The configuration must be done using the user-set allocation method.

**Step 1** Configure the Option Board and Network as explained in sections 3-1 *Installation of EDS files* and 3-2 *Configuring the Option Board*. Use the Advanced Setting for the Slave to select both the Poll connection as the specific COS connections.

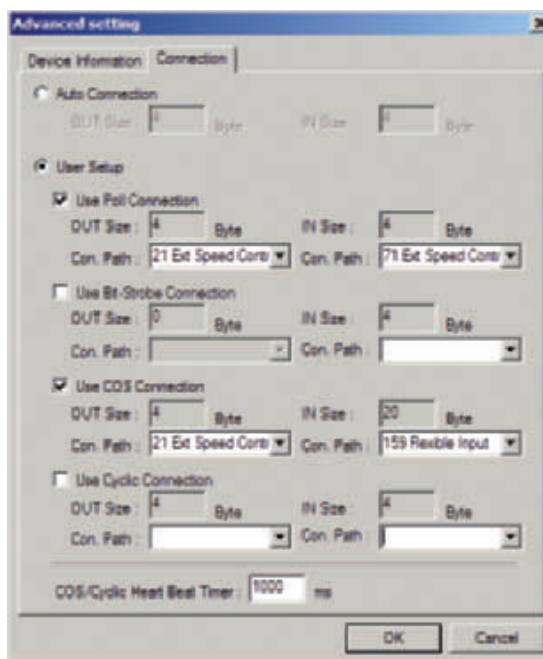

**Note 1** The output assembly of the COS connection is the same as for the Poll connection, in this case assembly 21 Extended Speed Control.

**Note 2** The default length of the 159 Flexible input is 20 bytes, you can change this as explained in the next step.

**Step 2** To change the specific size of the assembly, select the I/O Allocation Tab and modify the size in the Edit I/O Allocate window according the input data size.

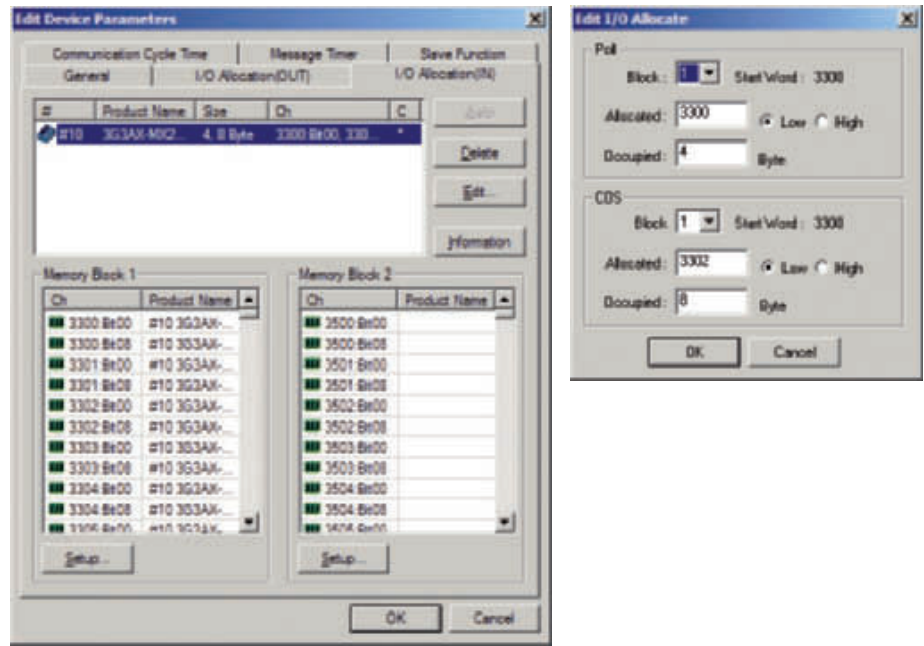

**Step 3** Set the Flexible format parameter P170 to P179 to the Modbus address required. For example:

Table 23 COS Parameters

Parameter	Allocated Modbus register	Value
P170	Trip cause of current Inverter trip	0012 Hex
P171	d002: Output current monitor	1003 Hex
P172	d012: Torque monitor	1010 Hex
P173	d013: Output voltage monitor	1011 Hex

Note the other parameters P160 to P169 and P174 to P179 are zero.

**Step 4** Download the configuration to the Master Unit and also restart the Inverter to apply the new values of the parameters.

The resulting configuration will have additional monitoring of inverter status specifically to the application’s requirements. Please note that for the COS also Bit-Strobe can be used as an alternative.



# SECTION 5

## Troubleshooting and Maintenance

### 5-1 Troubleshooting Using the LED Indicators

The two bi-color LED indicators on the Option Board provide information on the Option Board mode and status and the network status.

When an error occurs, the Option Board trips the Inverter so that an error code is displayed on the four-digit display of the Inverter. Use the error code to help troubleshoot the error.

In the following sections typical LED indicator and four-digit Inverter display patterns are provided to assist in troubleshooting. To show the status of the indicators, the following conventions are used:

- MS      OFF
- MS      RED
- MS      GREEN
- MS      Flashing
- MS      Not important (Ignore)
- MS      Inverter error code
- 000      Not important (Ignore)

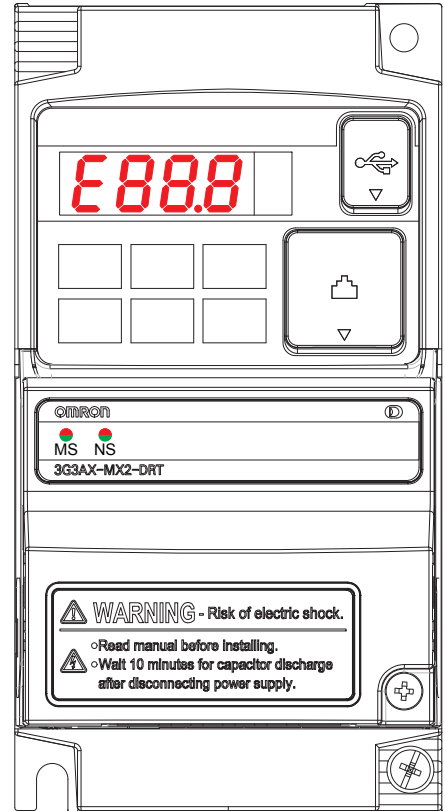

**Tip** Do not clear the trip before you are finished troubleshooting an error. When you clear the trip, the error code is cleared from the four-digit display. You may therefore lose the error information before you are able to start troubleshooting. Checking data in trip history is still an option in this case.

#### 5-1-1 Option Board or Inverter Errors







During the Initialization process the MS and NS indicator shortly blink GREEN and RED to show correct operation of the indicator. Once the initialization has been completed correctly, the MS indicator will lit GREEN and the NS indicator will be OFF. The table below shows the indicator and display patterns caused by Option Board or Inverter Errors.

Table 24 Option Board or Inverter Errors

Display & Indicators	Possible Cause(s)	Corrective Action
	The Inverter does not power up.	Follow the instruction provided in the MX2 User's manual (Cat. No. I570) section 6-1-4 to troubleshoot.
	The Option Board connector is damaged	Replace the Option Board.
	The Inverter RS input is ON	Switch the Inverter RS input OFF.

Table 24 Option Board or Inverter Errors

Display & Indicators	Possible Cause(s)	Corrective Action
	The Option Board encountered a fatal error during Power-on	Check that the Option Board is mounted properly and restart the Option Board. If the problem persists, replace the Option Board.
	The Inverter does not support a 3G3AX-MX2-DRT-E (Refer to section 5-1-2 Configuration Errors)	Replace the Inverter with a later version.
	The Option Board connector is damaged	Replace the Option Board.
	The Option Board encountered a fatal error during Operation.	Check that the option is mounted properly and restart the Option Board. If the problem persists, replace the Option Board
	The Inverter is tripped with the Force external Fault/Trip through the fieldbus.	Clear the FFL Force external fault bit and reset the trip.
	The Inverter detected a fatal error in the operation of the Option Board.	Check that the option is mounted properly and restart the Option Board. If the problem persists, replace the Option Board



### 5-1-2 Configuration Errors



If the Option Board is correctly configured, the MS indicator will lit GREEN. The table below shows the indicator and display patterns caused by configuration errors.

Table 25 Configuration Errors

Display & Indicators	Possible Cause(s)	Corrective Action
	One of the configuration parameters P160 – P179 has been rejected by the Inverter.	Check (and correct) the following items: STEP I: <ul style="list-style-type: none"> <li>Is one of the parameters P160 – P179 specifying a Modbus register that does not exist?</li> <li>If one of the parameters P160 – P169 is specifying a double-word Modbus register: Are both the low- and high-words specified in sequence by two consecutive parameters?</li> <li>If one of the parameters P170 – P179 is specifying a double-word Modbus register: Are both the high- and low-words specified in sequence by two consecutive parameters?</li> <li>Is a specific Modbus register specified twice in the output parameter registers P160 – P169?</li> <li>Is one of the output parameters P160 – P169 specifying a Modbus register that is read only? (A register is read-only if it has an 'R' in the 'R/W' column in section B-4-2 of the MX2 User's manual (Cat. No. I570).)</li> <li>Is one of the output parameters P160 – P169 specifying a Modbus register of which the parameter is not run-mode editable? (A parameter is not run-mode editable if it has an 'x' in the 'Run Mode Edit' column in section 3 of the MX2 User's manual.)</li> </ul> STEP II: Restart the system by one of the following method <ul style="list-style-type: none"> <li>Power OFF and ON</li> <li>Press the stop button on the Operator panel.</li> <li>Use the RS function of the intelligent input terminal.</li> </ul> Recovery via the fieldbus: <ul style="list-style-type: none"> <li>Use Modbus Class Object to set the Trip reset coil (04h) in coil register 0x1F01.</li> </ul>
	Your Inverter settings are not compatible with this version of the 3G3AX-MX2-DRT-E.	<ul style="list-style-type: none"> <li>Check P046 value in range [0..7] and restart unit.</li> <li>Reset the Inverter to factory defaults. If the problem persists, contact your local OMRON representative for assistance.</li> </ul>

### 5-1-3 DeviceNet Errors





If the DeviceNet master is correctly configured and there are no wiring errors, the NS indicator will lit GREEN. The table below shows the indicator patterns caused by configuration DeviceNet errors.

Table 26 DeviceNet Errors

Display & Indicators	Possible Cause(s)	Corrective Action
	Waiting for connection	-
	Device Node address (P192) does not match current online address of the Unit.	Restart the Unit.
	The DeviceNet master cannot communicate with the Option Board because the node address is already is use.	Check (and correct) the following items: Does the Master Unit or any other slave device on the DeviceNet network also have the same node address?

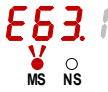
Table 26 DeviceNet Errors

Display & Indicators	Possible Cause(s)	Corrective Action
	The Option Board detects: communication idle or communication timeout during RUN mode (P044).	Check (and correct) the following items: Is the DeviceNet master sending IDLE messages? Check P048 to select the Action on Network Idle.  Increase the value of P044, the timeout value. (COS/Cyclic connections require the P044 time-out to be set to a value larger than the heart-beat timer).
	Network power failure.	Check (and correct) the following items: Are the correct pins wired on the DeviceNet connector? Are there any short circuits or line interruptions? Is the correct power supplied (between 11 and 25V)?
	Critical link failure. The Option Board detects too many communication errors. (CAN bus off.)	Check (and correct) the following items: Are the correct pins wired on the DeviceNet connector? Are there any short circuits or line interruptions? Is the ground cable of the option board connected with a ground terminal of the MX2 Inverter? Are the MX2 installation guidelines to comply with EMC recommendations properly implemented (refer to MX2 User's manual (Cat. No. I570) section D-1)? Are you using the correct cable type? If you have branches from the DeviceNet cable main line: Are any of these branches too long? Are the terminators mounted on both ends of the trunk only? Is noise interference excessive?
	Connection time-out. The Option Board detects communication lost.	Check (and correct) the following items: Are the correct pins wired on the DeviceNet connector? Are there any short circuits or line interruptions?

### 5-1-4 Commissioning Mode



When using one of the OMRON tools during commissioning time, the 3G3AX-MX2-DRT-E can be set into commissioning mode. A clear indication will be given by the tool.

Commissioning mode is NOT an error, but it can influence normal system operation. During commissioning mode, Inverter parameter access takes priority over cyclic data exchange. Accessing Inverter parameters will therefore delay cyclic data exchange causing unexpected latencies.

**Caution** Make sure that commissioning mode is disabled before operating the system.

## 5-2 Other Error Causes and Error Procedures

This section explains about errors which are not shown as specific LED indicator states.

Table 27 Other errors

Error event	Possible cause and procedure
Within CX-Integrator, the download or upload of the parameters of the Unit fail.	The Inverter may have limited write access to the parameters based on the Inverter mode selected. The Inverter may be in Trip state, which prevents parameters to be downloaded. Check the proper Inverter mode and state before attempting downloading again.
Explicit message access of the parameters (using Function Code object or Modbus Register object) fail.	The Inverter may have limited write access to the parameters based on the Inverter mode selected. The Inverter may be in Trip state, which prevents parameters to be downloaded. Check the proper Inverter mode and state before attempting downloading again.

## 5-3 Maintenance and Inspection

### 5-3-1 Replacing the Option Board

**⚠ HIGH VOLTAGE** Always Switch OFF the mains power supply to the Inverter before removing the Option Board. Wait for the time specified on the Inverter front cover for the capacitors to discharge. Not doing so may result in electrical shock.

**Step 1** Loosen the faulty Option Board mounting screw.

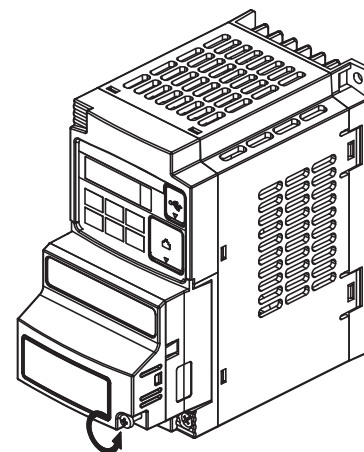

**Step 2** Pull the faulty Option Board straight out of the Inverter while pushing down on the indicated sides to release the snap-fits.

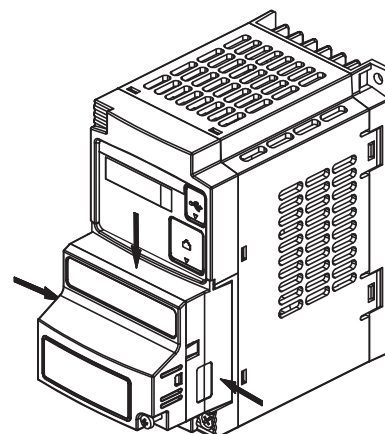

**Step 3** For Inverters up to 4.0 kW only: loosen the screw(s) of the terminal block cover and remove the cover to enable access to the chassis ground terminal screws.

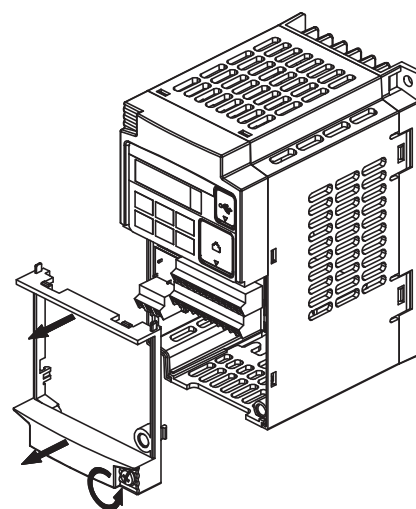

**Step 4** Unscrew and remove the faulty Option Board grounding cable. Keep the screw and washers, but set the faulty Option Board aside.

1-phase 200 V 0.1 - 2.2 kW  
 3-phase 200 V 0.1 - 3.7 kW  
 3-phase 400 V 0.4 - 4.0 kW

3-phase 200 V 5.5 - 15 kW  
 3-phase 400 V 5.5 - 15 kW

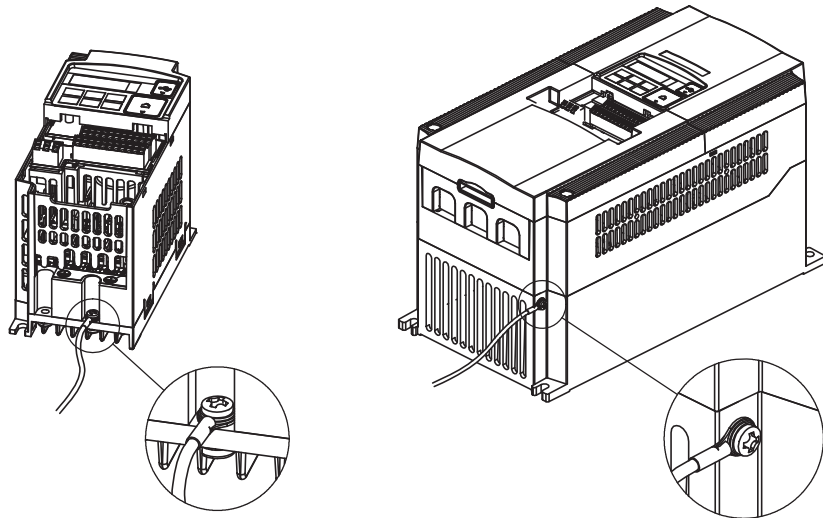

**Step 5** Secure the replacement Option Board grounding cable to the MX2-A Inverter using the mounting screw saved in . Unscrew and remove the faulty Option Board grounding cable. Keep the screw and washers, but set the faulty Option Board aside.

**Step 6** If removed in Step 3, mount the terminal cover again and tighten the screw(s).

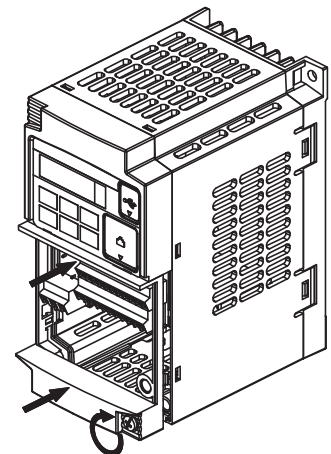

**Step 7** Push the replacement Option Board into Inverter to replace the removed Option Board until it clicks into place

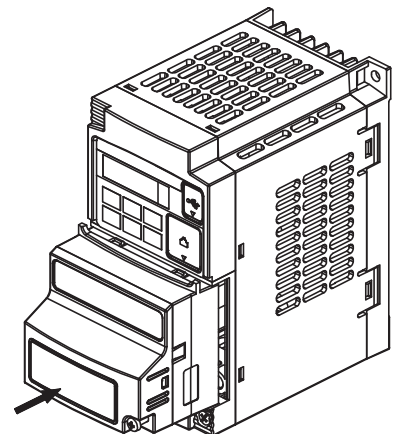

**Step 8** Press down on the indicated corner of the replacement option board housing to ensure proper connection of the option board connector

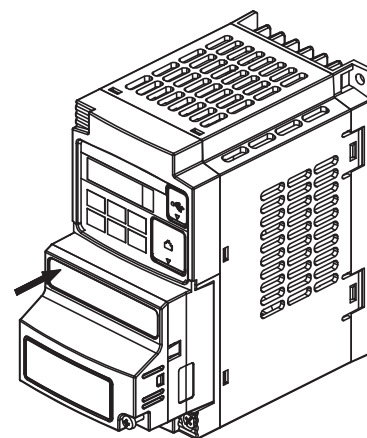

**Step 9** Check that there is no gap between the top edges of the replacement Option Board and the Inverter casing.

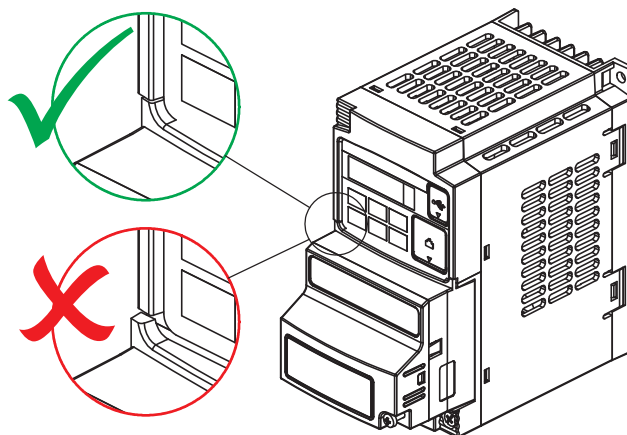

**Step 10** Secure the replacement Option Board in place with the mounting screw (do not over-tighten).

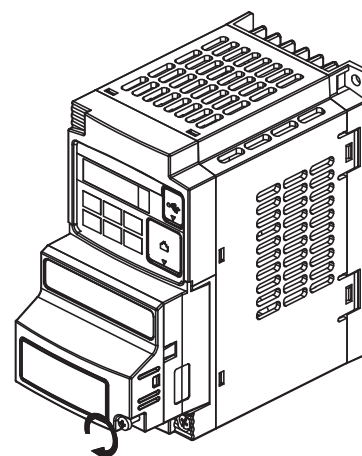

**Caution** When replacing an Inverter be sure that all Inverter settings of the Inverter being replaced are restored to the replacement.

# APPENDIX A

## Glossary

<b>Bit Strobe</b>	In case a Slave unit is configured for bit strobe data exchange, it will send data immediately when it has received a broadcast request (Input only).
<b>Bus off</b>	A bus off condition occurs when an large ragte of errors is detected on the CAN bus by the device. The device can no longer receive or transmit messages on the network. This condition is often caused by noise on the network or incorrect data rate setting.
<b>Change of state (COS)</b>	<p>In case a Slave unit is configured for change of state data exchange, it will send data immediately when its data has changed. This mechanism reduces the network traffic as unchanged data does not need to be transmitted.</p> <p>The mechanism does have a maximum time interval after which unchanged data will be transferred.</p>
<b>Cyclic I/O</b>	In case a Slave unit is configured for cyclic I/O data exchange, it will send data at a fixed user-configurable time interval.
<b>Electronic Data Sheet (EDS) Files</b>	Text files which are used by network configuration tools such as CX-Integrator to configure the system. The configuration consists of DeviceNet network related settings and may contain additional configurable parameters.
<b>Explicit Messaging</b>	Explicit messages are acyclic communication messages used for configuration or monitoring the devices over DeviceNet
<b>Inverter</b>	A device that electronically changes DC to AC current through an alternating process of switching the input to the output, inverted and non-inverted. It contains three inverter circuits to generate 3-phase output to the motor.
<b>Polled I/O</b>	In case a Slave unit is configure for Polled I/O data exchange, it will send data immediately when it has received a request for the data.
<b>Torque</b>	The rotational force exerted by a motor shaft. The units of measurement consist of the distance (radius from shaft center axis) and force (weight) applied at that distance. Units are usually given as pound-feet, ounce-inches, or Newton-meters.
<b>Trip event</b>	An event that causes the inverter to stop operation is called a "trip" event (as in tripping a circuit breaker). The inverter keeps a history log of trip events. They also require an action to clear.





# APPENDIX B

## Assembly Specification

### B-1 Basic Speed Control IO (20/70)

#### Assembly ID 20: Basic Speed Control Output

Table B-1 Basic Speed Control Output - Assembly 20 Allocation

Word	Byte	Bit Allocation							
		Bit 7	Bit 6	Bit 5	Bit 4	Bit 3	Bit 2	Bit 1	Bit 0
n	0	-	-	-	-	-	RST	-	FWD
	1	-	-	-	-	-	-	-	-
n + 1	2	Rotational Speed Reference (Low Byte)							
	3	Rotational Speed Reference (High Byte)							

Table B-2 Basic Speed Control Output - Assembly 20 Description

Name	Description
FWD	Forward run command 0: Stop 1: Forward run
RST	Fault reset Reset fault / trip condition on transition from 0 to 1
Rotational Speed Reference	Reference rotational speed. Unit: [RPM]/[0.1 Hz]/[0.01 Hz].  If Motor poles setting for RPM (inverter parameter P049 is set to zero, the Unit depends on the inverter mode (d060): d060 = 2 (High Frequency mode): Unit is [0.1 Hz] d060 != 2 (High Frequency mode): Unit is [0.01 Hz]

**Note** For safety reasons, the FWD, REV and RST command operation requires a rising edge (0 to 1 transition) after power on and fault/trip reset.

#### Assembly ID 70: Basic Speed Control Input

Table B-3 Basic Speed Control Input - Assembly 70 Allocation

Word	Byte	Bit Allocation							
		Bit 7	Bit 6	Bit 5	Bit 4	Bit 3	Bit 2	Bit 1	Bit 0
n	0	-	-	-	-	-	DFR	-	FLT
	1	-	-	-	-	-	-	-	-
n + 1	2	Rotational Speed Monitor (Low Byte)							
	3	Rotational Speed Monitor (High Byte)							

Table B-4 Basic Speed Control Input - Assembly 70 Description

Name	Description
FLT	Fault 0: Normal 1: Fault/trip
DFR	During forward run 0: Stop/reverse 1: During forward run
Rotational Speed Monitor	Actual rotational speed monitor. Unit: [RPM]/[0.1 Hz]/[0.01 Hz].  If Motor poles setting for RPM (inverter parameter P049 is set to zero, the Unit depends on the inverter mode (d060): d060 = 2 (High Frequency mode): Unit is [0.1 Hz] d060 != 2 (High Frequency mode): Unit is [0.01 Hz]

## B-2 Extended Speed Control IO (21/71)

### Assembly ID 21: Extended Speed Control Output

Table B-5 Extended Speed Control Output - Assembly 21 Allocation

Word	Byte	Bit Allocation							
		Bit 7	Bit 6	Bit 5	Bit 4	Bit 3	Bit 2	Bit 1	Bit 0
n	0	-	REF	CTR	-	-	RST	REV	FWD
	1	-	-	-	-	-	-	-	-
n + 1	2	Rotational Speed Reference (Low Byte)							
	3	Rotational Speed Reference (High Byte)							

Table B-6 Extended Speed Control Output - Assembly 21 Description

Name	Description
FWD	Forward run command 0: Stop 1: Forward run
REV	Reverse run command 0: Stop 1: Reverse run
RST	Fault reset Reset fault / trip condition on transition from 0 to 1
CTR	NetCtrl run command selection 0: Setting of inverter parameter A002 1: Network controlled
REF	NetRef speed reference selection 0: Setting of inverter parameter A001 1: Network controlled
Rotational Speed Reference	Reference rotational speed. Unit: [RPM]/[0.1 Hz]/[0.01 Hz].  If Motor poles setting for RPM (inverter parameter P049 is set to zero, the Unit depends on the inverter mode (d060): d060 = 2 (High Frequency mode): Unit is [0.1 Hz] d060 != 2 (High Frequency mode): Unit is [0.01 Hz]

**Note** For safety reasons, the FWD, REV and RST command operation requires a rising edge (0 to 1 transition) after power on and fault/trip reset.

### Assembly ID 71: Extended Speed Control Input

Table B-7 Extended Speed Control Input - Assembly 71 Allocation

Word	Byte	Bit Allocation							
		Bit 7	Bit 6	Bit 5	Bit 4	Bit 3	Bit 2	Bit 1	Bit 0
n	0	ARF	RFN	CFN	RDY	DRR	DFR	WR	FLT
	1	Drive status							
n + 1	2	Rotational Speed Monitor (Low Byte)							
	3	Rotational Speed Monitor (High Byte)							

Table B-8 Extended Speed Control Input - Assembly 71 Description

Name	Description
FLT	Fault 0: Normal 1: Fault/trip
WR	Warning 0: Normal 1: Warning
DFR	During forward run 0: Stop/reverse 1: During forward run
DRR	During reverse run 0: Stop/forward 1: During reverse run

Table B-8 Extended Speed Control Input - Assembly 71 Description (continued)

Name	Description
RDY	Inverter ready status 0: Inverter not ready 1: Inverter ready
CFN	Ctrl from net: run command input selection 0: Local 1: Devicenet reference
RFN	Ref from net: speed reference input selection 0: Local 1: Devicenet reference
ARF	At reference 0: Acceleration or deceleration phase 1: At reference
Drive Status	Drive Status 1: Startup 2: Not ready 3: Ready 4: Enabled 5: Stopping 6: Fault / trip stop 7: Faulted / tripped
Rotational Speed Monitor	Actual rotational speed monitor. Unit: [RPM]/[0.1 Hz]/[0.01 Hz].  If Motor poles setting for RPM (inverter parameter P049 is set to zero, the Unit depends on the inverter mode (d060): d060 = 2 (High Frequency mode): Unit is [0.1 Hz] d060 != 2 (High Frequency mode): Unit is [0.01 Hz]

### B-3 Extended Speed and Torque Control IO (123/173)

**Assembly ID 123:  
Extended Speed and  
Torque Control Output**

Table B-9 Extended Speed and Torque Control Output - Assembly 123 Allocation

Word	Byte	Bit Allocation							
		Bit 7	Bit 6	Bit 5	Bit 4	Bit 3	Bit 2	Bit 1	Bit 0
n	0	-	REF	CTR	-	-	RST	REV	FWD
	1	-	-	-	-	-	-	-	-
n + 1	2	Rotational Speed Reference (Low Byte)							
	3	Rotational Speed Reference (High Byte)							
n + 2	4	Torque Reference (Low Byte)							
	5	Torque Reference (High Byte)							

Table B-10 Extended Speed and Torque Control Output - Assembly 123 Description

Name	Description
FWD	Forward run command 0: Stop 1: Forward run
REV	Reverse run command 0: Stop 1: Reverse run
RST	Fault reset Reset fault / trip condition on transition from 0 to 1
CTR	NetCtrl run command selection 0: Setting of inverter parameter A002 1: Network controlled
REF	NetRef speed reference selection 0: Setting of inverter parameter A001 1: Network controlled

Table B-10 Extended Speed and Torque Control Output - Assembly 123 Description

Name	Description
Rotational Speed Reference	Reference rotational speed. Unit: [RPM]/[0.1 Hz]/[0.01 Hz].  If Motor poles setting for RPM (inverter parameter P049 is set to zero, the Unit depends on the inverter mode (d060): d060 = 2 (High Frequency mode): Unit is [0.1 Hz] d060 != 2 (High Frequency mode): Unit is [0.01 Hz]
Torque Reference	Reference torque. Unit: [%]

**Note** For safety reasons, the FWD, REV and RST command operation requires a rising edge (0 to 1 transition) after power on and fault/trip reset.

**Assembly ID 173:  
Extended Speed and  
Torque Control Input**

Table B-11 Extended Speed and Torque Control Input - Assembly 173 Allocation

Word	Byte	Bit Allocation							
		Bit 7	Bit 6	Bit 5	Bit 4	Bit 3	Bit 2	Bit 1	Bit 0
n	0	ARF	RFN	CFN	RDY	DRR	DFR	WR	FLT
	1	Drive status							
n + 1	2	Rotational Speed Monitor (Low Byte)							
	3	Rotational Speed Monitor (High Byte)							
n + 2	4	Torque Actual (Low Byte)							
	5	Torque Actual (High Byte)							

Table B-12 Extended Speed and Torque Control Input - Assembly 173 Description

Name	Description
FLT	Fault 0: Normal 1: Fault/trip
WR	Warning 0: Normal 1: Warning
DFR	During forward run 0: Stop/reverse 1: During forward run
DRR	During reverse run 0: Stop/forward 1: During reverse run
RDY	Inverter ready status 0: Inverter not ready 1: Inverter ready
CFN	Ctrl from net: run command input selection 0: Local 1: Devicenet reference
RFN	Ref from net: speed reference input selection 0: Local 1: Devicenet reference
ARF	At reference 0: Acceleration or deceleration phase 1: At reference
Drive Status	Drive Status 1: Startup 2: Not ready 3: Ready 4: Enabled 5: Stopping 6: Fault / trip stop 7: Faulted / tripped

Table B-12 Extended Speed and Torque Control Input - Assembly 173 Description

Name	Description
Rotational Speed Monitor	Actual rotational speed monitor. Unit: [RPM]/[0.1 Hz]/[0.01 Hz].  If Motor poles setting for RPM (inverter parameter P049 is set to zero, the Unit depends on the inverter mode (d060): d060 = 2 (High Frequency mode): Unit is [0.1 Hz] d060 != 2 (High Frequency mode): Unit is [0.01 Hz]
Torque Actual	Actual torque monitor. Unit: [%]

## B-4 Special IO (100/150)

### Assembly ID 100: Special Output

Table B-13 Special Output - Assembly 100 Allocation

Word	Byte	Bit Allocation							
		Bit 7	Bit 6	Bit 5	Bit 4	Bit 3	Bit 2	Bit 1	Bit 0
n	0	Function Code							
	1	-							
n + 1	2	Register Number (Low Byte)							
	3	Register Number (High Byte)							
n + 2	4	Register Data Word 0 (Low Byte)							
	5	Register Data Word 0 (High Byte)							
n + 3	6	Register Data Word 1 (Low Byte)							
	7	Register Data Word 1 (High Byte)							

Table B-14 Special Output - Assembly 100 Description

Name	Description
Function Code	Special IO function code (in Hex): 03 Read single word 10 Write single word 43 Read double word 50 Write double word  Note these codes are not the same as the explicit message service code.
Register Number	The modbus register number corresponding to a specific inverter parameter to be written.
Register Data Word 0 / 1	The data to write to the specified register. Word 0 is the least significant word. Word 1 is the most significant word (zero in case of single word write).

### Assembly ID 150: Special Input

Table B-15 Special Input - Assembly 150 Allocation

Word	Byte	Bit Allocation							
		Bit 7	Bit 6	Bit 5	Bit 4	Bit 3	Bit 2	Bit 1	Bit 0
n	0	Function Code							
	1	-							
n + 1	2	Register Number (Low Byte)							
	3	Register Number (High Byte)							
n + 2	4	Register Data Word 0 (Low Byte)							
	5	Register Data Word 0 (High Byte)							
n + 3	6	Register Data Word 1 (Low Byte)							
	7	Register Data Word 1 (High Byte)							

Table B-16 Special Input - Assembly 150 Description

Word	Byte	Write success	Read success	Failure
n	0	0x10 / 0x50	0x03 / 0x43	Function code OR'ed with 0x80
	1	-	-	-
n + 1	2	Register Number (Low Byte)		
	3	Register Number (High Byte)		
n + 2	4	-	Register Data Word 0 (Low Byte)	Fault code
	5	-	Register Data Word 0 (High Byte)	-
n + 3	6	-	Register Data Word 1 (Low Byte)	-
	7	-	Register Data Word 1 (High Byte)	-

The error codes for the Special IO operation are listed here below.

Table B-17 Special Input - Assembly 150 Errors

Fault code	Name	Description
01 Hex	Function code error	A code other than 03 / 10 / 43 or 50 Hex has been set as function code.
02 Hex	Register number error	The specified register number does not exist.
04 Hex	Slave device failure	Option inverter communication failure
21 Hex	Data setting error	An upper or lower limit for the write data setting range was exceeded
22 Hex	Writing mode error	The inverter is in the wrong mode
23 Hex	Register size error.	Used 2 bytes read/write on 4 bytes register or 4 bytes read/write on 2 bytes register

## B-5 Extended Control IO (101/151/153)

### Assembly ID 101: Extended Control Output

Table B-18 Extended Control Output - Assembly 101 Allocation

Word	Byte	Bit Allocation							
		Bit 7	Bit 6	Bit 5	Bit 4	Bit 3	Bit 2	Bit 1	Bit 0
n	0	-	CI7	CI6	CI5	CI4	CI3	REV	FWD
	1	CO2	CO1	CR	-	-	-	RST	FFL
n + 1	2	Rotational Speed Reference (Low Byte)							
	3	Rotational Speed Reference (High Byte)							
n + 2	4	Torque Reference (Low Byte)							
	5	Torque Reference (High Byte)							
n + 3	6	Torque Compensation Bias (Low Byte)							
	7	Torque Compensation Bias (High Byte)							

Table B-19 Extended Control Output - Assembly 101 Description

Name	Description
FWD	Forward run command 0: Stop 1: Forward run
REV	Reverse run command 0: Stop 1: Reverse run
CI3 - CI7	Control / override for multi function input terminal [3] to [7] 0: Reset 1: Override input

Table B-19 Extended Control Output - Assembly 101 Description (continued)

Name	Description
FFL	Force external fault/trip Set external fault / trip state on transition from 0 to 1
RST	Fault reset Reset fault / trip condition on transition from 0 to 1
C01, C02, CR	Set (relay) output 0: Reset 1: Set multi function output [1] to [2] or relay output (CR)
Rotational Speed Reference	Reference rotational speed. Unit: [RPM]/[0.1 Hz]/[0.01 Hz].  If Motor poles setting for RPM (inverter parameter P049 is set to zero, the Unit depends on the inverter mode (d060): d060 = 2 (High Frequency mode): Unit is [0.1 Hz] d060 != 2 (High Frequency mode): Unit is [0.01 Hz]
Torque Reference	Reference torque. Unit [%]
Torque Compensation Bias	Compensation bias torque. Unit: [%]

**Note** For safety reasons, the FWD, REV and RST command operation requires a rising edge (0 to 1 transition) after power on and fault/trip reset.

**Assembly ID 151:  
Extended Control Input**

Table B-20 Extended Control Input - Assembly 151 Allocation

Word	Byte	Bit Allocation							
		Bit 7	Bit 6	Bit 5	Bit 4	Bit 3	Bit 2	Bit 1	Bit 0
n	0	FLT	WR	RDY	ARF	-	DRR	DZS	DFR
	1	-	-	MO2	MO1	MR	CFN	-	-
n + 1	2	Rotational Speed Monitor (Low Byte)							
	3	Rotational Speed Monitor (High Byte)							
n + 2	4	Torque Actual (Low Byte)							
	5	Torque Actual (High Byte)							
n + 3	6	Output Current Monitor (Low Byte)							
	7	Output Current Monitor (High Byte)							

Table B-21 Extended Control Input - Assembly 151 Description

Name	Description
DFR	During forward run 0: Stop/reverse 1: During forward run
DZS	During zero speed 0: Non-zero speed 1: During zero speed
DRR	During reverse run 0: Stop/forward 1: During reverse run
ARF	At reference 0: Acceleration or deceleration phase 1: At reference
RDY	Inverter ready status 0: Inverter not ready 1: Inverter ready
WR	Warning 0: Normal 1: Warning
FLT	Fault 0: Normal 1: Fault/trip

Table B-21 Extended Control Input - Assembly 151 Description (continued)

Name	Description
CFN	Ctrl from net: run command input selection 0: Local 1: Devicenet reference
MO1, MO2, MR	Monitor (relay) outputs 0: OFF 1: ON
Rotational Speed Monitor	Actual rotational speed monitor. Unit: [RPM]/[0.1 Hz]/[0.01 Hz].  If Motor poles setting for RPM (inverter parameter P049 is set to zero, the Unit depends on the inverter mode (d060): d060 = 2 (High Frequency mode): Unit is [0.1 Hz] d060 != 2 (High Frequency mode): Unit is [0.01 Hz]
Torque Actual	Actual torque monitor. Unit: [%]
Output current monitor	Output current monitor. Unit: [0.1 A]

**Assembly ID 153:  
Extended Control + Multi  
Function Input**

Table B-22 Extended Control + Multi Function Input - Assembly 153 Allocation

Word	Byte	Bit Allocation							
		Bit 7	Bit 6	Bit 5	Bit 4	Bit 3	Bit 2	Bit 1	Bit 0
n	0	FLT	WR	RDY	ARF	-	DRR	DZS	DFR
	1	-	-	MO2	MO1	MR	CFN	-	-
n + 1	2	Rotational Speed Monitor (Low Byte)							
	3	Rotational Speed Monitor (High Byte)							
n + 2	4	Torque Actual (Low Byte)							
	5	Torque Actual (High Byte)							
n + 3	6	Output Current Monitor (Low Byte)							
	7	Output Current Monitor (High Byte)							
n + 4	8	-	MI7	MI6	MI5	MI4	MI3	MI2	MI1

Table B-23 Extended Control + Multi Function Input - Assembly 153 Description

Name	Description
DFR	During forward run 0: Stop/reverse 1: During forward run
DZS	During zero speed 0: Non-zero speed 1: During zero speed
DRR	During reverse run 0: Stop/forward 1: During reverse run
ARF	At reference 0: Acceleration or deceleration phase 1: At reference
RDY	Inverter ready status 0: Inverter not ready 1: Inverter ready
WR	Warning 0: Normal 1: Warning
FLT	Fault 0: Normal 1: Fault/trip
CFN	Ctrl from net: run command input selection 0: Local 1: Devicenet reference



Table B-23 Extended Control + Multi Function Input - Assembly 153 Description

Name	Description
MO1, MO2, MR	Monitor (relay) outputs 0: OFF 1: ON
Rotational Speed Monitor	Actual rotational speed monitor. Unit: [RPM]/[0.1 Hz]/[0.01 Hz].  If Motor poles setting for RPM (inverter parameter P049 is set to zero, the Unit depends on the inverter mode (d060): d060 = 2 (High Frequency mode): Unit is [0.1 Hz] d060 != 2 (High Frequency mode): Unit is [0.01 Hz]
Torque Actual	Actual torque monitor. Unit: [%]
Output current monitor	Output current monitor. Unit: [0.1 A]
MI1 to MI7	Monitor multi function inputs [1] to [7] 0: OFF 1: ON

## B-6 Extended Speed and Acceleration Control IO (110/111)

Assembly ID 110:  
Extended Speed and Acceleration Control Output

Table B-24 Extended Speed and Acceleration Control Output - Assembly 110 Allocation

Word	Byte	Bit Allocation							
		Bit 7	Bit 6	Bit 5	Bit 4	Bit 3	Bit 2	Bit 1	Bit 0
n	0	-	REF	CTR	-	FRS	RST	REV	FWD
	1	-	-	-	-	-	-	-	-
n + 1	2	Rotational Speed Reference (Low Byte)							
	3	Rotational Speed Reference (High Byte)							
n + 2	4	Acceleration Time (Low Byte)							
	5	Acceleration Time (High Byte)							
n + 3	6	Deceleration Time (Low Byte)							
	7	Deceleration Time (High Byte)							

Table B-25 Extended Speed and Acceleration Control Output - Assembly 110 Description

Name	Description
FWD	Forward run command 0: Stop 1: Forward run
REV	Reverse run command 0: Stop 1: Reverse run
RST	Fault reset Reset fault / trip condition on transition from 0 to 1
FRS	Activate Free run stop (coasting) 0: No action 1: Free run stop
CTR	NetCtrl run command selection 0: Setting of inverter parameter A002 1: Network controlled
REF	NetRef speed and acceleration/deceleration reference selection 0: Setting of inverter parameters A001, F002 and F003 1: Network controlled
Rotational Speed Reference	Reference rotational speed. Unit: [RPM]/[0.1 Hz]/[0.01 Hz].  If Motor poles setting for RPM (inverter parameter P049 is set to zero, the Unit depends on the inverter mode (d060): d060 = 2 (High Frequency mode): Unit is [0.1 Hz] d060 != 2 (High Frequency mode): Unit is [0.01 Hz]

Table B-25 Extended Speed and Acceleration Control Output - Assembly 110 Description (continued)

Name	Description
Acceleration time	Reference acceleration time. Unit: [0.1 s] Range of setting [0.1 to 3600.0] Be sure to set the REF bit to control the acceleration or deceleration time using this assembly. Otherwise the F002 and F003 will be used independent of parameter A001.
Deceleration time	Reference deceleration time. Unit: [0.1 s] Range of setting [0.1 to 3600.0] Be sure to set the REF bit to control the acceleration or deceleration time using this assembly. Otherwise the F002 and F003 will be used independent of parameter A001.

**Note** For safety reasons, the FWD, REV and RST command operation requires a rising edge (0 to 1 transition) after power on and fault/trip reset.

**Assembly ID 111:  
Extended Speed and  
Acceleration Control Input**

Table B-26 Extended Speed and Acceleration Control Input - Assembly 111 Allocation

Word	Byte	Bit Allocation							
		Bit 7	Bit 6	Bit 5	Bit 4	Bit 3	Bit 2	Bit 1	Bit 0
n	0	MI3	MI2	MI1	ARF	-	FLT	DRR	DFR
	1	Drive status							
n + 1	2	Rotational Speed Monitor (Low Byte)							
	3	Rotational Speed Monitor (High Byte)							
n + 2	4	Output Current Monitor (Low Byte)							
	5	Output Current Monitor (High Byte)							
n + 3	6	Trip Cause							
	7	RFN	CFN	-	-	MI7	MI6	MI5	MI4

Table B-27 Extended Speed and Acceleration Control Input - Assembly 111 Description

Name	Description
DFR	During forward run 0: Stop/reverse 1: During forward run
DRR	During reverse run 0: Stop/forward 1: During reverse run
FLT	Fault 0: Normal 1: Fault/trip
ARF	At reference 0: Acceleration or deceleration phase 1: At reference
MI1 to MI7	Monitor multi function inputs [1] to [7] 0: OFF 1: ON
CFN	Ctrl from net: run command input selection 0: Local 1: Devicenet reference
RFN	Ref from net: speed reference input selection 0: Local 1: Devicenet reference

Table B-27 *Extended Speed and Acceleration Control Input - Assembly 111*  
 Description (continued)

Name	Description
Drive Status	Drive Status 1: Startup 2: Not ready 3: Ready 4: Enabled 5: Stopping 6: Fault / trip stop 7: Faulted / tripped
Rotational Speed Monitor	Actual rotational speed monitor. Unit: [RPM]/[0.1 Hz]/[0.01 Hz].  If Motor poles setting for RPM (inverter parameter P049 is set to zero, the Unit depends on the inverter mode (d060): d060 = 2 (High Frequency mode): Unit is [0.1 Hz] d060 != 2 (High Frequency mode): Unit is [0.01 Hz]
Output current monitor	Output current monitor. Unit: [0.1 A]
Trip Cause	Returns direct trip cause. Value 1 to 99 decimal correspond to trip E01 to E99.



# APPENDIX C

## General Object Specification

### C-1 Identity Object (Class 0x01)

Supported Service Codes Table C-1 Identity Object - Supported Service Codes

Service Code No. (hex)	Service
0E	Get attribute single
05	Reset (return to initial status)

#### Object Details

Table C-2 Identity Object - Object Details

Instance (hex)	Attribute (hex)	Name	Content	Setting range	Default	Get	Set	Size
01	01	Vendor ID	Indicates the manufacturer's ID	----	47 (OMRON Corporation)	Yes	No	UINT
	02	Device Type	Indicates the DeviceNet profile classification	----	2 (AC Drive)	Yes	No	UINT
	03	Product Code	Product code depending on the MX2-A□ inverter model. See note.	----	Depending on inverter	Yes	No	UINT
	04	Revision	Indicates overall software revision for DeviceNet Option Board and Inverter  Note this attribute depends on both the Option Board and the Inverter. Be sure to match the correct EDS file to this revision for configuration.	----	Depending on unit	Yes	No	WORD
	05	Status	Indicates communications status for DeviceNet Option board  Bit allocation: 0: Always ON 8: Minor Recoverable Fault 9: Minor Unrecoverable Fault 10: Major Recoverable Fault 11: Major Unrecoverable Fault	----	0 Hex	Yes	No	UINT
	06	Serial Number	Indicates the serial number of the DeviceNet Option board	----	Unique for each unit	Yes	No	LONG
	07	Product Name	Product name depending on the MX2-A□ inverter model. See note.	----	Depending on inverter	Yes	No	UINT
	09	Configuration Consistency Value	Indicates the consistency value which is incremented if an inverter parameter is changed and stored to EEPROM through the Option Board interface.  Please note changes using the other Inverter interfaces (Serial, Digital operator) will not influence this attribute.  Writing to EEPROM save (Modbus address 0900 Hex, class 64 Hex, instance 09 Hex, attribute 0 Hex) will also increment this value.	----	0 Hex	Yes	No	UINT
	65	Firmware Revision Option Board	Indicates software version of the DeviceNet Option board.	----	Depending on unit	Yes	No	WORD

**Note** The product code and the product name depend on the MX2-A□ of inverter being used, as shown in the following table]

Table C-3 Model List

MX2-A□ Model Name	Product Name	Product Code (Dec)	EDS File
MX2-AB001-E, MX2-A2001-E	3G3AX-MX2-DRT-AB001_A2001-E	1880	3G3AX-MX2-DRT-AB001_A2001-E.eds
MX2-AB002-E, MX2-A2002-E	3G3AX-MX2-DRT-AB002_A2002-E	1881	3G3AX-MX2-DRT-AB002_A2002-E.eds
MX2-AB004-E, MX2-A2004-E	3G3AX-MX2-DRT-AB004_A2004-E	1882	3G3AX-MX2-DRT-AB004_A2004-E.eds
MX2-AB007-E, MX2-A2007-E	3G3AX-MX2-DRT-AB007_A2007-E	1884	3G3AX-MX2-DRT-AB007_A2007-E.eds
MX2-AB015-E, MX2-A2015-E	3G3AX-MX2-DRT-AB015_A2015-E	1886	3G3AX-MX2-DRT-AB015_A2015-E.eds
MX2-AB022-E, MX2-A2022-E	3G3AX-MX2-DRT-AB022_A2022-E	1887	3G3AX-MX2-DRT-AB022_A2022-E.eds
MX2-A2037-E	3G3AX-MX2-DRT-A2037-E	1889	3G3AX-MX2-DRT-A2037-E.eds
MX2-A2055-E	3G3AX-MX2-DRT-A2055-E	1891	3G3AX-MX2-DRT-A2055-E.eds
MX2-A2075-E	3G3AX-MX2-DRT-A2075-E	1892	3G3AX-MX2-DRT-A2075-E.eds
MX2-A2110-E	3G3AX-MX2-DRT-A2110-E	1893	3G3AX-MX2-DRT-A2110-E.eds
MX2-A2150-E	3G3AX-MX2-DRT-A2150-E	1894	3G3AX-MX2-DRT-A2150-E.eds
MX2-A4004-E	3G3AX-MX2-DRT-A4004-E	1902	3G3AX-MX2-DRT-A4004-E.eds
MX2-A4007-E	3G3AX-MX2-DRT-A4007-E	1904	3G3AX-MX2-DRT-A4007-E.eds
MX2-A4015-E	3G3AX-MX2-DRT-A4015-E	1906	3G3AX-MX2-DRT-A4015-E.eds
MX2-A4022-E	3G3AX-MX2-DRT-A4022-E	1907	3G3AX-MX2-DRT-A4022-E.eds
MX2-A4030-E	3G3AX-MX2-DRT-A4030-E	1908	3G3AX-MX2-DRT-A4030-E.eds
MX2-A4040-E	3G3AX-MX2-DRT-A4040-E	1910	3G3AX-MX2-DRT-A4040-E.eds
MX2-A4055-E	3G3AX-MX2-DRT-A4055-E	1911	3G3AX-MX2-DRT-A4055-E.eds
MX2-A4075-E	3G3AX-MX2-DRT-A4075-E	1912	3G3AX-MX2-DRT-A4075-E.eds
MX2-A4110-E	3G3AX-MX2-DRT-A4110-E	1913	3G3AX-MX2-DRT-A4110-E.eds
MX2-A4150-E	3G3AX-MX2-DRT-A4150-E	1914	3G3AX-MX2-DRT-A4150-E.eds

## C-2 Message Router Object (Class 0x02)

**Object Details** No vendor specific attributes are supported.

## C-3 DeviceNet Object (Class 0x03)

**Supported Service Codes** Table C-4 DeviceNet Object - Supported Service Codes

Service Code No. (hex)	Service
0E	Get attribute single
10	Set attribute single

**Object Details**

Table C-5 DeviceNet Object - Object Details

Instance (hex)	Attribute (hex)	Name	Content	Setting range	Default	Get	Set	Size
01	01	MAC ID	Node address of option board	0-63	63	Yes	Yes	USINT
	02	Baud rate	Baud rate of option board: 0: 125 kbit/s 1: 250 kbit/s 2: 500 kbit/s	0-2	0	Yes	No	UINT
	03	BOI	BOI Bus-Off interruption	----	0	Yes	No	BOOL
	04	Bus-Off Counter	Number of Bus-Off detection	----	0	Yes	No	USINT
	05	Allocation Information	DeviceNet communication connection information	----	0	Yes	No	WORD
	06	MAC ID Switch Changed	Node address changed after power-on or reset	----	0	Yes	No	BOOL
	08	MAC ID Switch Value	Node address setting actual value	----	63	Yes	No	UINT

## C-4 Assembly Object (Class 0x04)

### Supported Service Codes

Table C-6 Assembly Object - Supported Service Codes

Service Code No. (hex)	Service
0E	Get attribute single
10	Set attribute single

### Object Details

Table C-7 Assembly Object - Object Details

Instance (hex)	Attribute (hex)	Name	Content	Setting range	Default	Get	Set	Size
14	03	Remote I/O Data	Data same as Basic Speed IO (Output)	----	00 00 00 00	Yes	Yes	BYTE x 4
15	03	Remote I/O Data	Data same as Extended Speed IO (Output)	----	00 00 00 00	Yes	Yes	BYTE x 4
46	03	Remote I/O Data	Data same as Basic Speed IO (Input)	----	00 00 00 00	Yes	No	BYTE x 4
47	03	Remote I/O Data	Data same as Extended Speed IO (Input)	----	00 00 00 00	Yes	No	BYTE x 4
64	03	Remote I/O Data	Data same as Special IO (Output)	----	00 00 00 00 00 00 00 00	Yes	Yes	BYTE x 8
65	03	Remote I/O Data	Data same as Extended Control IO (Output)	----	00 00 00 00 00 00 00 00	Yes	Yes	BYTE x 8
6E	03	Remote I/O Data	Data same as Extended Speed and Acceleration Control (Output)	----	00 00 00 00 00 00 00 00	Yes	Yes	BYTE x 8
6F	03	Remote I/O Data	Data same as Extended Speed and Acceleration Control (Input)	----	00 00 00 00 00 00 00 00	Yes	No	BYTE x 8
7B	03	Remote I/O Data	Data same as Extended Speed and Torque Control (Output)	----	00 00 00 00 00 00	Yes	Yes	BYTE x 6
8B	03	Remote I/O Data	Flexible IO (Output)	----	00 00 00 00 00 00 00 00 00 00 00 00 00 00 00 00 00 00 00 00	Yes	Yes	BYTE x 20 max (see note 2)
96	03	Remote I/O Data	Data same as Special IO (Input)	----	00 00 00 00 00 00 00 00	Yes	No	BYTE x 8
97	03	Remote I/O Data	Data same as Extended Control IO (Input)	----	00 00 00 00 00 00 00 00	Yes	No	BYTE x 8
99	03	Remote I/O Data	Data same as Extended Control IO and Multi-Function monitor (Input)	----	00 00 00 00 00 00 00 00 00	Yes	No	BYTE x 9
9F	03	Remote I/O Data	Flexible IO (Input)	----	00 00 00 00 00 00 00 00 00 00 00 00 00 00 00 00 00 00 00 00	Yes	No	BYTE x 20 max (see note 2)

**Note 1** The data allocation of the assembly in this objects are the same as defined in Appendix B.

**Note 2** The size of the Flexible IO assemblies are depending on the actual configuration.



## C-5 Connection Object (Class 0x05)

### Supported Service Codes

Table C-8 Connection Object - Supported Service Codes

Service Code No. (hex)	Service
0E	Get attribute single
10	Set attribute single

### Object Details

Table C-9 Connection Object - Object Details

Instance (hex)	Attribute (hex)	Name	Content	Setting range	Default	Get	Set	Size
01 Explicit	01	State	Status of the instance	----	3	Yes	No	USINT
	02	Instance type	Type of the instance	----	0	Yes	No	USINT
	03	TransportClass_Trigger	Defines behaviour of the connection	----	83 Hex	Yes	No	BYTE
	04	DeviceNet_Produced_Connection_ID	Label indicating communication ID as set by DeviceNet master Unit.	----	----	Yes	No	UINT
	05	DeviceNet_Consumed_Connection_ID	Label indicating communication ID as set by DeviceNet master Unit.	----	----	Yes	No	UINT
	06	Initial Comm characteristics	Indicates the communication configuration for the DeviceNet master Unit.	----	21 Hex	Yes	No	BYTE
	07	Produced connection size	Indicates the maximum number of bytes for transmission.	----	260	Yes	No	UINT
	08	Consumed connection size	Indicates the maximum number of bytes for reception.	----	260	Yes	No	UINT
	09	Expected packet rate	Indicates the length of the internal processing timeout when a communication request is received (incremented by 10 ms units)	0 - 65535	0	Yes	Yes	UINT
	0C	Watchdog timeout action	Indicates the action for internal processing timeout related to communications. 00: Retain timeout status (until reset or cleared) 01: Cut connection automatically 02: Operate again with same connection as is	----	1	Yes	Yes	USINT
	0D	Produced connection path length	Number of bytes for produced connection path. No data for explicit messages	----	0	Yes	No	UINT
	0E	Produced connection path	Specifies the application object for produced connection path. No data for explicit messages	----	Empty	Yes	No	ARRAY
	0F	Consumed connection path length	Number of bytes for consumed connection path. No data for explicit messages	----	0	Yes	No	UINT
	10	Consumed connection path	Specifies the application object for consumed connection path. No data for explicit messages	----	Empty	Yes	No	ARRAY
11	Production inhibit time	Specifies the production inhibit timer value.	----	0	Yes	No	UINT	
12	Connection timeout multiplier	Specifies the multiplier for the connection timeout event.	----	Fixed to 4	Yes	No	USINT	

Table C-9 Connection Object - Object Details (continued)

Instance (hex)	Attribute (hex)	Name	Content	Setting range	Default	Get	Set	Size
02 Polled I/O	01	State	Status of the instance	----	----	Yes	No	USINT
	02	Instance type	Type of the instance	----	1	Yes	No	USINT
	03	TransportClass_Trigger	Defines behaviour of the connection	----	82 Hex	Yes	No	BYTE
	04	DeviceNet_Produced_Connection_ID	Label indicating communication ID as set by DeviceNet master Unit	----	----	Yes	No	UINT
	05	DeviceNet_Consumed_Connection_ID	Label indicating communication ID as set by DeviceNet master Unit	----	----	Yes	No	UINT
	06	Initial Comm characteristics	Indicates the communication configuration for the DeviceNet master Unit	----	01 Hex	Yes	No	BYTE
	07	Produced connection size	Indicates the maximum number of bytes for transmission	----	Depending on assembly configured	Yes	No	UINT
	08	Consumed connection size	Indicates the maximum number of bytes for reception	----	Depending on assembly configured	Yes	No	UINT
	09	Expected packet rate	Indicates the length of the internal processing timeout when a communication request is received. Unit is ms, value is set as multiple of 10 ms.	0 - 65535	0	Yes	Yes	UINT
	0C	Watchdog timeout action	Indicates the action for internal processing timeout related to communications. 00: Retain timeout status (until reset or cleared)	----	0	Yes	No	USINT
	0D	Produced connection path length	Number of bytes for produced connection path	----	3	Yes	No	UINT
	0E	Produced connection path	Specifies the application object for produced connection path	----	Depending on Default Connection Path	Yes	No	ARRAY
	0F	Consumed connection path length	Number of bytes for consumed connection path	----	3	Yes	No	UINT
	10	Consumed connection path	Specifies the application object for consumed connection path	----	Depending on Default Connection Path	Yes	No	ARRAY
11	Production inhibit time	Specifies the production inhibit timer value.	----	0	Yes	No	UINT	
12	Connection timeout multiplier	Specifies the multiplier for the connection timeout event.	----	Fixed to 4	Yes	No	USINT	

Table C-9 Connection Object - Object Details (continued)

Instance (hex)	Attribute (hex)	Name	Content	Setting range	Default	Get	Set	Size
03 Bit- Strobe	01	State	Status of the instance	----	----	Yes	No	USINT
	02	Instance type	Type of the instance	----	1	Yes	No	USINT
	03	TransportClass_Trigger	Defines behaviour of the connection	----	82 Hex	Yes	No	BYTE
	04	DeviceNet_Produced_Connection_ID	Label indicating communication ID as set by DeviceNet master Unit	----	----	Yes	No	UINT
	05	DeviceNet_Consumed_Connection_ID	Label indicating communication ID as set by DeviceNet master Unit	----	----	Yes	No	UINT
	06	Initial Comm characteristics	Indicates the communication configuration for the DeviceNet master Unit	----	02 Hex	Yes	No	BYTE
	07	Produced connection size	Indicates the maximum number of bytes for transmission	----	Depending on assembly configured	Yes	No	UINT
	08	Consumed connection size	Indicates the maximum number of bytes for reception	----	0	Yes	No	UINT
	09	Expected packet rate	Indicates the length of the internal processing timeout when a communication request is received. Unit is ms, value is set as multiple of 10 ms.	0 - 65535	0	Yes	Yes	UINT
	0C	Watchdog timeout action	Indicates the action for internal processing timeout related to communications. 00: Retain timeout status (until reset or cleared)	----	0	Yes	No	USINT
	0D	Produced connection path length	Number of bytes for produced connection path	----	3	Yes	No	UINT
	0E	Produced connection path	Specifies the application object for produced connection path	----	Default: Flexible IO (Input) 62 39 46	Yes	No	ARRAY
	0F	Consumed connection path length	Number of bytes for consumed connection path	----	0	Yes	No	UINT
	10	Consumed connection path	Specifies the application object for consumed connection path	----	----	Yes	No	ARRAY
11	Production inhibit time	Specifies the production inhibit timer value.	----	0	Yes	No	UINT	
12	Connection timeout multiplier	Specifies the multiplier for the connection timeout event.	----	Fixed to 4	Yes	No	USINT	

Table C-9 Connection Object - Object Details (continued)

Instance (hex)	Attribute (hex)	Name	Content	Setting range	Default	Get	Set	Size
04 Change OfState Cyclic I/O	01	State	Status of the instance	----	----	Yes	No	USINT
	02	Instance type	Type of the instance	----	1	Yes	No	USINT
	03	TransportClass_Trigger	Defines behaviour of the connection	----	82 Hex	Yes	No	BYTE
	04	DeviceNet_Produced_Connection_ID	Label indicating communication ID as set by DeviceNet master Unit	----	----	Yes	No	UINT
	05	DeviceNet_Consumed_Connection_ID	Label indicating communication ID as set by DeviceNet master Unit	----	----	Yes	No	UINT
	06	Initial Comm characteristics	Indicates the communication configuration for the DeviceNet master Unit	----	01 Hex	Yes	No	BYTE
	07	Produced connection size	Indicates the maximum number of bytes for transmission	----	Depending on assembly configured	Yes	No	UINT
	08	Consumed connection size	Indicates the maximum number of bytes for reception	----	0	Yes	No	UINT
	09	Expected packet rate	Indicates the length of the internal processing timeout when a communication request is received. Unit is ms, value is set as multiple of 10 ms.	0 - 65535	0	Yes	Yes	UINT
	0C	Watchdog timeout action	Indicates the action for internal processing timeout related to communications. 00: Retain timeout status (until reset or cleared)	----	0	Yes	No	USINT
	0D	Produced connection path length	Number of bytes for produced connection path	----	3	Yes	No	UINT
	0E	Produced connection path	Specifies the application object for produced connection path	----	Default: Flexible IO (Input) 62 39 46	Yes	No	ARRAY
	0F	Consumed connection path length	Number of bytes for consumed connection path	----	4	Yes	No	UINT
	10	Consumed connection path	Specifies the application object for consumed connection path	----	Acknowledge Handler Object 20 2B 24 01	Yes	No	ARRAY
11	Production inhibit time	Specifies the production inhibit timer value.	----	0	Yes	Yes	UINT	
12	Connection timeout multiplier	Specifies the multiplier for the connection timeout event.	----	Fixed to 4	Yes	No	USINT	

## C-6 Discrete Input Point Object (Class 0x08)

**Supported Service Codes** *Table C-10 Discrete Input Point Object - Supported Service Codes*

Service Code No. (hex)	Service
0E	Get attribute single
10	Set attribute single

### Object Details

*Table C-11 Discrete Input Point Object - Object Details*

Instance (hex)	Attribute (hex)	Name	Content	Setting range	Default	Get	Set	Size
01 to 07 (See Note)	03	Value	Read input point value 0: Off 1: On	----	----	Yes	No	BOOL
	69	Override	Override input point value 0: Off 1: On	----	----	Yes	Yes	BOOL

**Note** The instance 1 to 7 correspond to the MX2-A□ inverter input terminal [1] to [7].

## C-7 Discrete Output Point Object (Class 0x09)

**Supported Service Codes** *Table C-12 Discrete Output Point Object - Supported Service Codes*

Service Code No. (hex)	Service
0E	Get attribute single
10	Set attribute single

### Object Details

*Table C-13 Discrete Output Point Object - Object Details*

Instance (hex)	Attribute (hex)	Name	Content	Setting range	Default	Get	Set	Size
01 to 03 (See note)	03	Value	Control the output point value 0: Off 1: On	----	----	Yes	Yes	BOOL

**Note** The instance 1 to 3 correspond to the MX2-A□ inverter output terminals respectively output [11], output [12] and alarm relay contacts (AL0,1,2).

## C-8 Unit Parameter Object (Class 0x94)

### Supported Service Codes

Table C-14 Unit Parameter Object - Supported Service Codes

Service Code No. (hex)	Service
0E	Get attribute single
10	Set attribute single

### Object Details

Table C-15 Unit Parameter Object - Object Details

Instance (hex)	Attribute (hex)	Name	Content	Setting range	Default	Get	Set	Size
01	64	Default Connection Path	<p>Selection of the default connection path. Actual value is read and written to inverter parameter P046.</p> <p>Please refer to <i>SECTION 3 Configuring Drive Parameters and Option Board</i> for details on P046.</p>	0 - 7	1	Yes	Yes	USINT

# APPENDIX D

## AC Drive Object Specification

### D-1 Motor Data Object (Class 0x28)

#### Supported Service Codes

Table D-1 Motor Data Object - Supported Service Codes

Service Code No. (hex)	Service
0E	Get attribute single
10	Set attribute single

#### Object Details

Table D-2 Motor Data Object - Object Details

Instance (hex)	Attribute (hex)	Name	Content	Setting range	Default	Get	Set	Size
01	03	Motor Type	Depends on the motor control mode which is selected for the inverter. The motor control mode can be read by inverter parameter d060.  Get values: 3: PM synchronous motor (d060 = 3) 7: Squirrel cage induction motor (d060 != 3)  Set values: 3: in case inverter control mode is not in this mode, the inverter will be set to PM synchronous mode (d060 = 3). 7: in case inverter control mode is PM synchronous mode (d060 = 3), the inverter will be set to ND mode (d060 = 1).  See note	----	7	Yes	Yes	US INT
	06	Rated Current	Motor rated current. Unit: [0.1 A]	----	Depend- ing on inverter type	Yes	Yes	UINT
	07	Rated Voltage	Motor rated voltage. Unit: [V]  Set: Only defined set of values as indicated for inverter parameter A082 (AVR voltage select) are accepted.	----	Depend- ing on inverter type	Yes	Yes	UINT
	08	Rated Power	Motor rated power. Unit: [W]  Set: Only defined set of values as indicated for inverter parameter H003 (Squirrel cage induction motor) or H103 (PM Synchronous mode) are accepted.	----	Depend- ing on inverter type	Yes	Yes	UINT
	09	Rated Frequency	Motor rated frequency. Unit: [Hz].	300 - MaxSpeed	50	Yes	Yes	UINT
	11	MaxSpeed	Maximum allowed motor speed. Unit: [RPM]	Depending on motor control mode	50	Yes	Yes	UINT
	12	PoleCount	Number of poles in the motor. (speed conversion only)  Only even number of poles are valid.	0 - 38	0	Yes	Yes	UINT

**Note** A change of the Motor Type value will cause an inverter and DeviceNet option board reset. This is equivalent to setting inverter parameters b171 (Inverter mode selection) and b180 (Parameter initialisation trigger).

## D-2 Control Supervisor Object (Class 0x29)

### Supported Service Codes

Table D-3 Control Supervisor Object - Supported Service Codes

Service Code No. (hex)	Service
0E	Get attribute single
10	Set attribute single

### Object Details

Table D-4 Control Supervisor Object - Object Details

Instance (hex)	Attribute (hex)	Name	Content	Setting range	Default	Get	Set	Size
01	03	Run1	Run Forward 0: Stop 1: Run Forward	----	0	Yes	Yes	BOOL
	04	Run2	Run Reverse 0: Stop 1: Run Reverse	----	0	Yes	Yes	BOOL
	05	Net Ctrl	Run command input is set 0: Setting of inverter parameter A002 1: DeviceNet reference	----	0	Yes	Yes	BOOL
	06	State	Drive status. See Appendix B for details.	----	----	Yes	No	UINT
	07	Running1	Forward Running 0: Stop 1: Forward Running	----	----	Yes	No	BOOL
	08	Running2	Reverse Running 0: Stop 1: Reverse Running	----	----	Yes	No	BOOL
	09	Ready	Inverter ready 0: Not ready 1: Ready	----	----	Yes	No	UINT
	0A	Faulted	Inverter fault / trip 0: No inverter fault / trip 1: Inverter fault / trip	----	----	Yes	No	BOOL
	0B	Warning	Inverter warning 0: No inverter warning 1: Inverter warning	----	----	Yes	No	BOOL
	0C	Fault Rst	Reset fault / trip state of inverter when written to 1.	----	0	Yes	Yes	BOOL
	0D	Fault Code	Current fault / trip state code. See note.	----	----	Yes	No	UINT
	0F	Ctrl From Net	Run command input selection 0: Setting of A002 1: DeviceNet controlled	----	----	Yes	No	BOOL
	10	Net Fault Mode	Inverter action on network error 0: Inverter fault / trip and stop (P045 = 1) 1: Ignore (P045 = 2) 2: Vendor specific.	----	2	Yes	Yes	UINT
	11	Force Fault	Force external fault / trip state for inverter on rising edge.	----	0	Yes	Yes	BOOL
	12	Force Status	Status external fault forced 0: Fault not forced 1: Fault forced	----	0	Yes	No	BOOL
	14	Net Idle Mode	Inverter action on network idle mode 0: Stop (P048 = 4) 1: Ignore (P048 = 2) 2: Vendor specific.	----	2	Yes	Yes	USINT
01	64	Drive State Detail	Drive State Detail value: 0: Stopping 1: Running 2: Jogging 3: Free running (coasting) 4: Direct current DC braking 5: Pickup (Decelerated stop) 7: During pickup (Retry) 8: Waiting (Retry) 10: Trip condition 11: Under-voltage condition	----	----	Yes	No	USINT
	65	Trip Cause	Returns direct trip cause (E01 to E99)	----	----	Yes	No	USINT
	66	Free Run	Activate Free run stop (coasting) 0: No action 1: Free run stop	----	0	Yes	Yes	BOOL



**Note** The following table shows the conversion between the MX2 Error or Trip code and the CIP Fault and Warning codes.

Table D-5 Error Code Conversion

MX2 Error/Trip code		CIP Fault and Warning Code	
Code	Name	Code	Name
E01	Over-current event while at constant speed	2200	Current Inside the Device
E02	Over-current event during deceleration	2214	Overcurrent during Slowdown
E03	Over-current event during acceleration	2213	Overcurrent during Startup
E04	Over-current event during other conditions	2200	Current Inside the Device
E05	Overload protection	2220	Continuous Overcurrent
E06	Braking resistor overload protection	7112	Brake Chopper overcurrent
E07	Over-voltage protection	3210	Overvoltage inside the device
E08	EEPROM error	6320	Parameter Error
E09	Under-voltage error	3220	Undervoltage inside the Device
E10	Current detection error	5210	Measurement Circuit
E11	CPU error	6100	Internal Software
E12	External trip	9000	External Malfunction
E13	USP	9000	External Malfunction
E14	Ground fault	2120	Short to Earth
E15	Input over-voltage	3110	Mains overvoltage
E16	Momentary electricity failure protection	3120	Mains undervoltage
E20	Temperature error with cooling fan frequency lowering	4000	Temperature
E21	Inverter thermal trip	4200	Device Temperature
E22	CPU error	5000	Device Hardware
E24	Phase Failure	3130	Phase Failure
E25	Main circuit error	5410	Output Stages
E30	Driver error	5400	Power section
E35	Thermistor	7300	Sensor
E36	Braking error	9000	External Malfunction
E37	Safe Stop	9000	External Malfunction
E38	Low-speed overload protection	2221	Continuous Overcurrent no 1
E40	Operator connection	5300	Operator control circuit
E41	Modbus communication error	7500	Communication
E43	EzSQ invalid instruction	6200	User Software
E44	EzSQ nesting count error	6200	User Software
E45	EzSQ instruction error	6200	User Software
E50 ...59	EzSQ user trip (0 to 9)	6200	User Software
E60	Option error (inverter communications error)	7510	Serial Interface No 1
E61	Option error (Duplicated MAC ID)	7510	Serial Interface No 1
E62	Option error (External trip)	7510	Serial Interface No 1
E63	DRT/CRT Communication lost / idle	7510	Serial Interface No 1
E64	Illegal flexible mapping	6320	Parameter error
E65 ...68	Option error (reserved)	7510	Serial Interface No 1

Table D-5 Error Code Conversion (continued)

MX2 Error/Trip code		CIP Fault and Warning Code	
Code	Name	Code	Name
E69	Option error (inverter communication lost error)	7510	Serial Interface No 1
E80	Encoder disconnection	7305	Incremental Encoder 1 Defective
E81	Excessive speed	8401	Velocity following error
E82	Positioning error	8500	Position
E83	Position control range error	8501	Position Following Error

## D-3 AC/DC Drive Object (Class 0x2A)

### Supported Service Codes

Table D-6 AC/DC Drive Object - Supported Service Codes

Service Code No. (hex)	Service
0E	Get attribute single
10	Set attribute single

### Object Details

Table D-7 AC/DC Drive Object - Object Details

Instance (hex)	Attribute (hex)	Name	Content	Setting range	Default	Get	Set	Size
1	03	At Reference	Status indication for at reference 0: Stopped, accelerating or decelerating 1: At reference	----	----	Yes	No	BOOL
	04	Net Ref	Speed reference selection 0: Setting of inverter parameter A002 1: Network controlled	0 - 1	0	Yes	Yes	BOOL
	06	Drive Mode	Fixed to value: 0: Vendor specific mode	0	0	Yes	Yes	USINT
	07	Speed Actual	Actual rotational speed monitor. Unit: [RPM]/[0.1 Hz]/[0.01 Hz].  If Motor poles setting for RPM (inverter parameter P049 is set to zero, the Unit depends on the inverter mode (d060): d060 = 2 (High Frequency mode): Unit is [0.1 Hz] d060 != 2 (High Frequency mode): Unit is [0.01 Hz]	----	----	Yes	No	INT
	08	Speed Ref	Reference rotational speed. Unit: [RPM]/[0.1 Hz]/[0.01 Hz].  If Motor poles setting for RPM (inverter parameter P049 is set to zero, the Unit depends on the inverter mode (d060): d060 = 2 (High Frequency mode): Unit is [0.1 Hz] d060 != 2 (High Frequency mode): Unit is [0.01 Hz]	0 - Max Speed	0	Yes	Yes	INT
	09	Current Actual	Output current monitor. Unit: [0.1 A]	----	----	Yes	No	INT
	0F	Power Actual	Output power monitor. Unit: [W]	----	----	Yes	No	INT
	11	Output Voltage	Output voltage monitor. Unit: [V]	----	----	Yes	No	INT
	12	Accel Time	Acceleration time. Unit: [ms]	10 - 3600000	10000	Yes	Yes	UINT
	13	Decel Time	Deceleration time. Unit: [ms]	10 - 3600000	10000	Yes	Yes	UINT
	1D	Ref From Net	Speed reference input selection monitor: 0: Local 1: Network reference	0 - 1	0	Yes	Yes	BOOL
	77	Torque Actual Rel	Actual torque monitor. Unit: [%]	----	----	Yes	Yes	INT
	78	Torque Ref Rel	Reference torque. Unit [%]	0 - 200	0	Yes	Yes	INT
	79	Torque Compensation Bias Rel	Compensation bias torque. Unit: [%]	-200 - 200	0	Yes	Yes	INT
7A	At Zero Speed	Status indication at zero speed 0: Non-zero speed 1: Zero speed	----	----	Yes	No	BOOL	



# APPENDIX E

## DeviceNet Explicit Messages

### E-1 Basic Format of Explicit Messages

The basic format of each command and response is shown below.

Command:

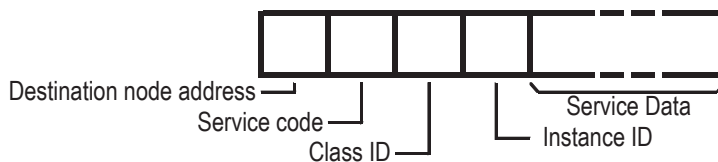

Response:

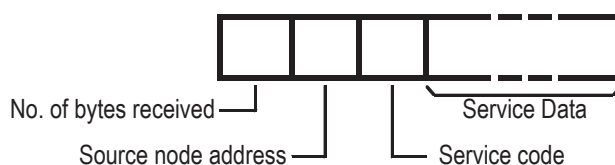

Service codes supported by the Unit are

Table E-1 Service Codes

Service	Read	Write	Reset
Command	0E Hex	10 Hex	05 Hex
Normal response	8E Hex	90 Hex	85 Hex

#### Example 1: Reset the Unit

Command:

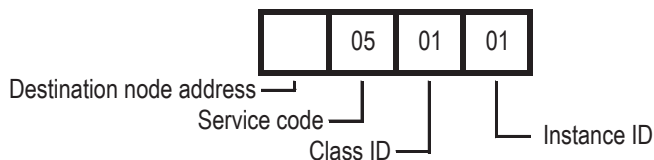

Response:

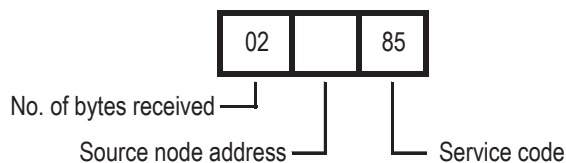

#### Example 2: Reading USINT Object Trip Cause

Parameter: Class 29 Hex, Instance 01 Hex, Attribute 65 Hex

Command:

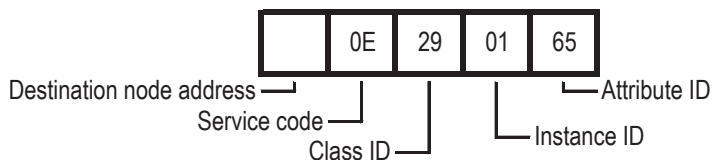

Response:

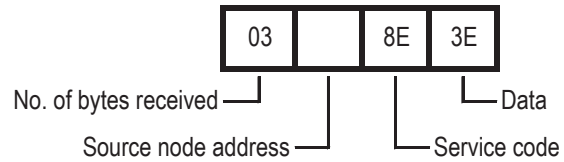

The latest trip of the inverter has been caused by E62 (value 3E Hex). This is Force fault/trip from the option board.

**Example 3:  
Writing BOOL Object  
ForceFault/Trip**

Parameter:Class 29 Hex, Instance 01 Hex, Attribute 11 Hex

Command:

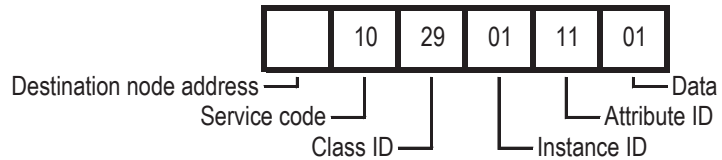

Response:

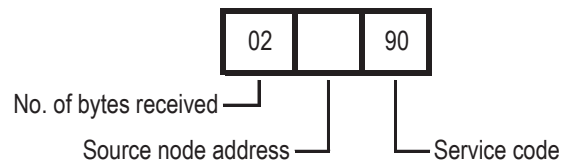

**Example 4:  
Read INT SpeedActual**

Parameter:Class 2A Hex, Instance 01 Hex, Attribute 07 Hex

Command:

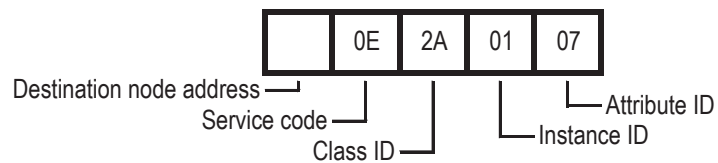

Response:

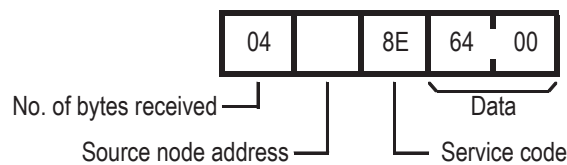

The actual speed is read as 10.0 Hz (0064 Hex). Please note the swapping of the data following CIP data type encoding.

## E-2 Function Code Object (Class 0x65)

### E-2-1 Supported Service Codes

Table E-2 Function Code Object (Class 0x65) Supported Service Codes

Service Code No. (hex)	Service
0E	Get attribute single
10	Set attribute single

### E-2-2 Supported Instance and Attribute Codes

The inverter parameter Function code are mapped to the object's instance and attributes.

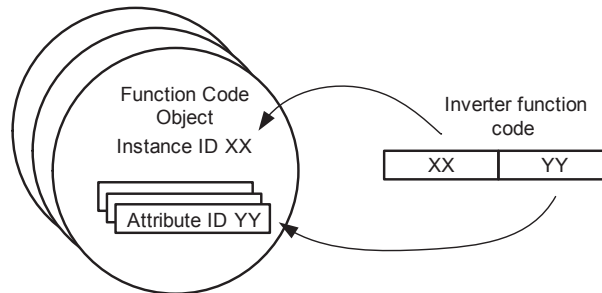

The instance and attribute are calculated using a sequence number of the function group (A = 0, B = 1, etc) \* 1000 plus the function code value. The resulting value is allocated to the instance (high byte) and attribute (low byte).

Table E-3 Function Code Object (Class 0x65) Supported Instance and Attribute Codes

Function Code	Decimal base	Decimal range	Hexadecimal range
A001 - A999	0	1 - 999	0001 - 03E7
b001 - b999	1000	1000 - 1999	03E9 - 07CF
C001 - C999	2000	2001 - 2999	07D1 - 0BB7
d001 - d999	3000	3001 - 3999	0BB9 - 0F9F
F001 - F999	5000	5001 - 5999	1389 - 176F
H001 - H999	7000	7001 - 7999	1B59 - 1F3F
P001 - P999	15000	15001 - 15999	3A99 - 3E7F
U001 - U999	20000	20001 - 20999	4E21 - 5207

- Note 1** Please refer to Appendix B of the MX2 User's Manual (Cat. No. I570) for details about Function code references and data sizes.
- Note 2** All data written by Function Code or Modbus Register object are stored temporary in the memory of the inverter. Be sure to execute the ENTER command at the end of writing sequence to store the value in EEPROM.
- Note 3** Function code F001 can not be written using the Function code object. The Function code B127 has a data size of 2 words (different from the Modbus register size of 1 word).

The ENTER command is executed by:

- enable the EEPROM write mode (write 01 Hex to Modbus address 0902 Hex)
- write to EEPROM (write 01 Hex to Modbus address 0900 Hex)

Both operation can be performed by using Modbus Register Object Class.

**Example 1:  
Reading single word  
Function Code**

Parameter:d005 Intelligent input terminal status  
Command:

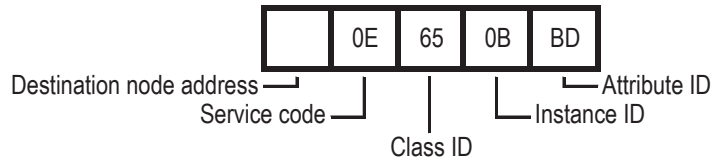

Response:

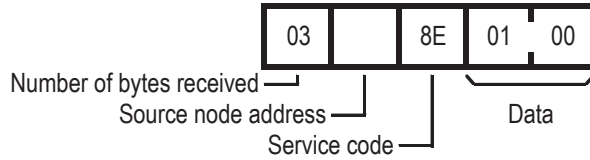

The instance and attribute are determined as value 3 (d) \* 1000 + 005 equals 3005 or 0BBD Hex. The response shows input 1 has been set. Please note the swapping of the data following CIP data type encoding.

**Example 2:  
Writing double word  
Function Code**

Parameter:P060 Multistage position 0 (value 128000, 01F400 Hex)  
Command:

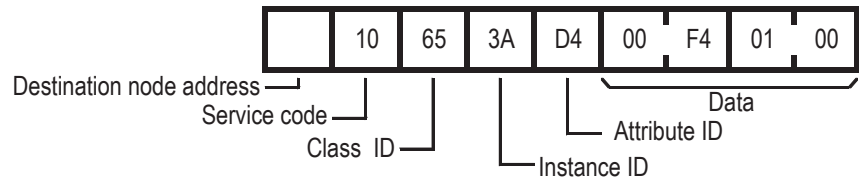

Response:

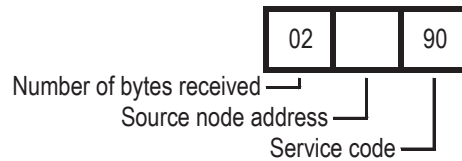

The instance and attribute are determined as value 15 (P) \* 1000 + 060 equals 15060 or 3AD4 Hex. Please note the swapping of the data following CIP data type encoding to set decimal value 128000.



## E-3 Modbus Register Object (Class 0x64)

### E-3-1 Supported Service Codes

Table E-4 Modbus Register Object (0x64) Supported Service Codes

Service Code No. (hex)	Service
0E	Get attribute single
10	Set attribute single

### E-3-2 Supported Instance and Attribute Codes

For this Object, the corresponding Modbus register of the inverter parameter are mapped to the object's instance and attribute.

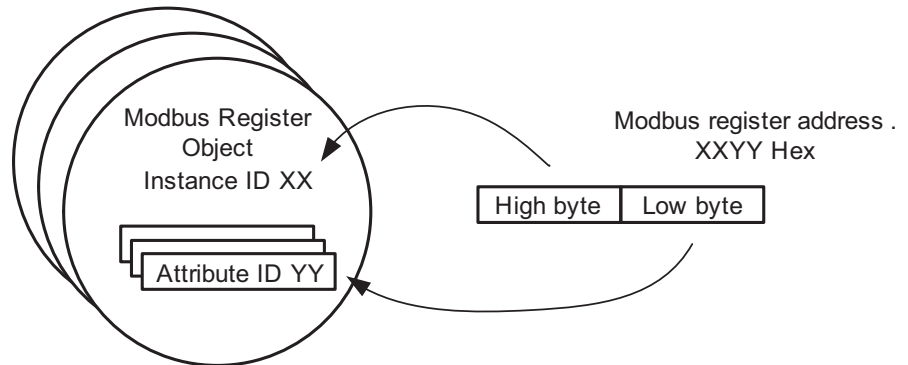

In case of the Modbus Address XXYY Hex, the instance of the object is mapped to XX and the attribute is mapped to YY.

**Note 1** Please refer to Appendix B of the MX2 User's Manual (Cat. No. I570) for details about Modbus registers and data sizes.

**Note 2** All data written by Function Code or Modbus Register object are stored temporary in the memory of the inverter. Be sure to execute the ENTER command at the end of writing sequence to store the value in EEPROM.

The ENTER command is executed by:

- enable the EEPROM write mode (write 01 Hex to Modbus address 0902 Hex)
- write to EEPROM (write 01 Hex to Modbus address 0900 Hex)

Both operation can be performed by using Modbus Register Object Class.

**Example 1:  
Reading single word  
Modbus register**

Parameter:Coil data 1 (address 1E01 Hex)  
Command:

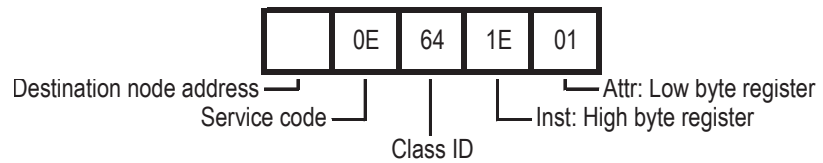

Response:

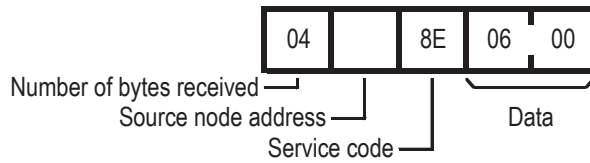

Please note the swapping of the data following CIP data type encoding.

**Example 2:  
Writing single word  
Modbus register**

Parameter:EEPROM Save parameter 0900 Hex (value 1 Hex)  
Command:

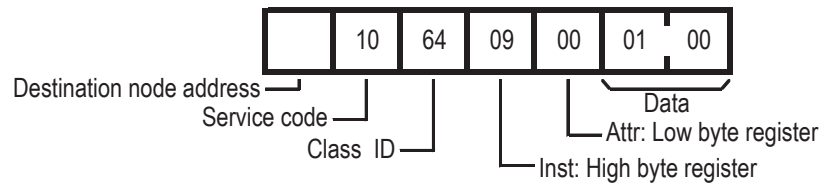

Response:

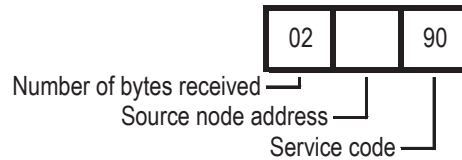

## E-4 Explicit Message Error Codes

When an error response has been returned for the executed explicit message, this response will have the following format.

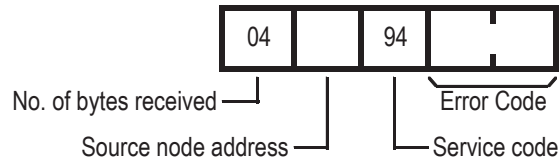

Within the frame, one of the following error codes will be included.

Table E-5 Error Response

Response Code	Error Name	Cause
02□□	Resource unavailable	An internal communication error between Option Board and Inverter
08□□	Service not supported	The service code is incorrect.
09□□	Invalid attribute value	The specified attribute / inverter parameter value is not supported. The data written is outside range.
0C□□	Object state conflict	The specified command cannot be executed due to an internal error.
0E□□	Attribute not settable	An attribute ID supported only for reading has been executed for a write service code.
10□□	Device state conflict	The specified command cannot be executed in this inverter mode.
13□□	Not enough data	The data is smaller than the specified size (accessing only high word of double word).
14□□	Attribute not supported	The attribute or inverter parameter does not exist.
15□□	Too much data	The data is larger than the specified size (accessing single word with double word data).
16□□	Object does not exist	The specified Instance ID is not supported.
1F□□	Vendor specific	This code is returned in case of an Inverter error.
20□□	Invalid parameter	The specified operation command data is not supported.



# APPENDIX F

## Flexible Format

The Flexible Format implements I/O data exchange that supports direct mapping of MX2-A□ Inverter Modbus registers in the I/O area. The Flexible Format provides

1. User configurable allocation of the IO Data to any Modbus register
2. Flexibility to set the size of the IO data to only transfer the necessary data, minimising fieldbus traffic.

This offers fieldbus- and profile-independent control of the MX2-A□ Inverter. The exchanged registers are configured by setting Inverter registers P160 – P179 to the appropriate Inverter Modbus addresses.

**Note** The MX2-A□ Inverter places some restrictions on the Modbus register selection.

- For a Modbus Register to be mapped for output data exchange, it must be both run-mode editable and writable.
- MX2-A□ Inverter parameters may not be accessible depending on the Inverter's mode (High frequency mode, Permanent magnet mode, Torque mode, etc).

**Tip** Refer to section B-4-2 of the MX2 User's manual

**Tip** Refer to section 3-2-3 of the MX2 User's manual

**Tip** The MX2-A□ Inverter parameter B031 (Software Lock Mode) determines the various protection levels. Be sure to set the appropriate value B031 = 10 to be able to set parameter during run-mode.

**Tip** When using Flexible Format, the Inverter is controlled via Modbus registers. Set A001/A201 = 3 and A002/A202 = 3 to make use of the Modbus control registers for typical Flexible Format use.

### Flexible I/O Mapping

Table F-1 Flexible Format I/O Mapping

Word Offset	Content	
	Output Area	Input Area
+0	Modbus register set by P160	Modbus register set by P170
+1	Modbus register set by P161	Modbus register set by P171
+2	Modbus register set by P162	Modbus register set by P172
+3	Modbus register set by P163	Modbus register set by P173
+4	Modbus register set by P164	Modbus register set by P174
+5	Modbus register set by P165	Modbus register set by P175
+6	Modbus register set by P166	Modbus register set by P176
+7	Modbus register set by P167	Modbus register set by P177
+8	Modbus register set by P168	Modbus register set by P178
+9	Modbus register set by P169	Modbus register set by P179

### Flexible I/O Settings

Please consider the following notes when setting the parameters P160 to P179.

**Note 1** The parameters P160 to P179 determine the size of the input and output data. The IO size is determined by the highest non-zero parameter. For example for output: if P164 is the highest non-zero parameter, the output data size will be

5 words.

Both output as input size should have a minimum size of 1 word.

**Note 2** Setting specific parameters in the range to 0 (not at the end), can be used to reserve IO memory. If set to 0 (zero), an output register is ignored and a 0 (zero) is mapped into an input register.

**Note 3** Double-word MX2 registers should be mapped with two modbus registers in sequence: high-word following low-word.  
Mapping only the low word in output data will write zero in the high word of the MX2 register.  
Mapping only the low word in input data is not allowed.

**Note 4** It is not allowed to map the same register more than once in the output area.

**Note 5** An incorrect setting of P160 to 179 will lead to a Major Recoverable Fault (MS blinking Red) and inverter trip state E64. In such case, correct the parameter values and restart (or reset, see *APPENDIX E DeviceNet Explicit Messages*) the Unit.

**Tip** In case the trip state E64 is generated, multiple incorrect settings in range P160 - 179 can have caused this error. If the error persists after some changes: it would be convenient to start with a small configuration which is correct and add a new register one by one (checking by restarting the Unit).

**Tip** Set the following register values:

- P160 = 1F01h: This gives you control over Modbus Coils 0000h through 000Fh using the first output word. These coils implement all the important control functions of the MX2-A□ Inverter.
- P161 = 0001h and P162 = 0002h: This gives you control over the frequency reference using output words 2 and 3.
- P170 = 1E01h: This allows you to monitor Modbus Coils 0010h through 001Fh as the first input word. These coils implement the most important status information of the MX2-A□ Inverter.
- P171 = 1001h and P172 = 1002h: This allows you to monitor the output frequency using input words 2 and 3.

The Modbus coil definitions for the MX2-A□ Inverter are listed in section B-4-1 of the MX2 User's manual (Cat. No. I570).

In case the output data is required to be as small as possible, please consider to only use register 0002h (instead of both 0001h and 0002h) as frequency reference. The resulting configuration is P160 = 1F01h and P161 = 0002h.

## Table index

Table 1	Option Board Specification . . . . .	3
Table 2	Device List. . . . .	4
Table 3	LED Indicators. . . . .	8
Table 4	Ground cable screw selection. . . . .	12
Table 5	DeviceNet connector signals. . . . .	13
Table 6	Option Board Dimensions . . . . .	14
Table 7	Configuration of Node Number . . . . .	15
Table 8	Default Connection Path . . . . .	15
Table 9	Configuration of Inverter Reset Mode Selection . . . . .	15
Table 10	Configuration of DeviceNet Parameters . . . . .	16
Table 11	Configuration of Source Selection Parameters. . . . .	16
Table 12	Configuration of Other Selection Parameter . . . . .	16
Table 13	Configuration of Flexible Mapping. . . . .	17
Table 14	Extended Speed I/O Output Words. . . . .	21
Table 15	Extended Speed I/O Input Words . . . . .	21
Table 16	Extended Speed Torque I/O Output Words . . . . .	24
Table 17	Extended Speed Torque I/O Input Words. . . . .	24
Table 18	Flex Mode Output Area with Typical Configuration. . . . .	28
Table 19	Flex Mode Input Area with Typical Configuration . . . . .	28
Table 20	Flex Mode Output Area with Motor Running Forward. . . . .	28
Table 21	Flex Mode Input Area with Motor Running Forward . . . . .	29
Table 22	Limitations Caused by Inverter Mode and Rating Selection . . . . .	30
Table 23	COS Parameters. . . . .	31
Table 24	Option Board or Inverter Errors. . . . .	33
Table 25	Configuration Errors . . . . .	35
Table 26	DeviceNet Errors. . . . .	35
Table 27	Other errors. . . . .	37
Table B-1	Basic Speed Control Output - Assembly 20 Allocation . . . . .	43
Table B-2	Basic Speed Control Output - Assembly 20 Description. . . . .	43
Table B-3	Basic Speed Control Input - Assembly 70 Allocation . . . . .	43
Table B-4	Basic Speed Control Input - Assembly 70 Description . . . . .	43
Table B-5	Extended Speed Control Output - Assembly 21 Allocation. . . . .	44
Table B-6	Extended Speed Control Output - Assembly 21 Description . . . . .	44
Table B-7	Extended Speed Control Input - Assembly 71 Allocation . . . . .	44
Table B-8	Extended Speed Control Input - Assembly 71 Description . . . . .	44
Table B-9	Extended Speed and Torque Control Output - Assembly 123 Allocation . . . . .	45
Table B-10	Extended Speed and Torque Control Output - Assembly 123 Description. . . . .	45
Table B-11	Extended Speed and Torque Control Input - Assembly 173 Allocation . . . . .	46
Table B-12	Extended Speed and Torque Control Input - Assembly 173 Description . . . . .	46
Table B-13	Special Output - Assembly 100 Allocation . . . . .	47
Table B-14	Special Output - Assembly 100 Description . . . . .	47
Table B-15	Special Input - Assembly 150 Allocation. . . . .	47
Table B-17	Special Input - Assembly 150 Errors. . . . .	48
Table B-16	Special Input - Assembly 150 Description. . . . .	48
Table B-18	Extended Control Output - Assembly 101 Allocation . . . . .	48
Table B-19	Extended Control Output - Assembly 101 Description . . . . .	48
Table B-20	Extended Control Input - Assembly 151 Allocation. . . . .	49
Table B-21	Extended Control Input - Assembly 151 Description. . . . .	49
Table B-22	Extended Control + Multi Function Input - Assembly 153 Allocation . . . . .	50
Table B-23	Extended Control + Multi Function Input - Assembly 153 Description . . . . .	50
Table B-24	Extended Speed and Acceleration Control Output - Assembly 110 Allocation. . . . .	51
Table B-25	Extended Speed and Acceleration Control Output - Assembly 110 Description. . . . .	51
Table B-26	Extended Speed and Acceleration Control Input - Assembly 111 Allocation . . . . .	52
Table B-27	Extended Speed and Acceleration Control Input - Assembly 111 Description . . . . .	52
Table C-1	Identity Object - Supported Service Codes. . . . .	55

Table C-2	Identity Object - Object Details . . . . .	55
Table C-3	Model List . . . . .	56
Table C-4	DeviceNet Object - Supported Service Codes . . . . .	56
Table C-5	DeviceNet Object - Object Details . . . . .	57
Table C-6	Assembly Object - Supported Service Codes . . . . .	58
Table C-7	Assembly Object - Object Details . . . . .	58
Table C-8	Connection Object - Supported Service Codes . . . . .	59
Table C-9	Connection Object - Object Details . . . . .	59
Table C-10	Discrete Input Point Object - Supported Service Codes . . . . .	63
Table C-11	Discrete Input Point Object - Object Details . . . . .	63
Table C-12	Discrete Output Point Object - Supported Service Codes . . . . .	63
Table C-13	Discrete Output Point Object - Object Details . . . . .	63
Table C-14	Unit Parameter Object - Supported Service Codes . . . . .	64
Table C-15	Unit Parameter Object - Object Details . . . . .	64
Table D-1	Motor Data Object - Supported Service Codes . . . . .	65
Table D-2	Motor Data Object - Object Details . . . . .	65
Table D-3	Control Supervisor Object - Supported Service Codes . . . . .	66
Table D-4	Control Supervisor Object - Object Details . . . . .	66
Table D-5	Error Code Conversion . . . . .	67
Table D-6	AC/DC Drive Object - Supported Service Codes . . . . .	69
Table D-7	AC/DC Drive Object - Object Details . . . . .	69
Table E-1	Service Codes . . . . .	71
Table E-2	Function Code Object (Class 0x65) Supported Service Codes . . . . .	73
Table E-3	Function Code Object (Class 0x65) Supported Instance and Attribute Codes . . . . .	73
Table E-4	Modbus Register Object (0x64) Supported Service Codes . . . . .	75
Table E-5	Error Response . . . . .	77
Table F-1	Flexible Format I/O Mapping . . . . .	79



## Revision history

A manual revision code appears as a suffix to the catalog number on the front cover of the manual.

Cat. No. I112E-EN-01

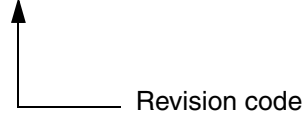

The following table outlines the changes made to the manual during each revision. Page numbers refer to the previous version.

Revision code	Date	Revised content
01	July 2010	Original production