

DeviceNet Communications Unit E5ZN-DRT

Connect the E5ZN Modular Temperature Controller to DeviceNet

- The I/O link function allows setting and monitoring (e.g., of present values) for the E5ZN Modular Temperature Controller to be performed without communications programming.
- Up to 16 E5ZN Modular Temperature Controllers can be connected to one Unit.
- All the parameters for the E5ZN can be uploaded or downloaded in one operation using DeviceNet Configurator.

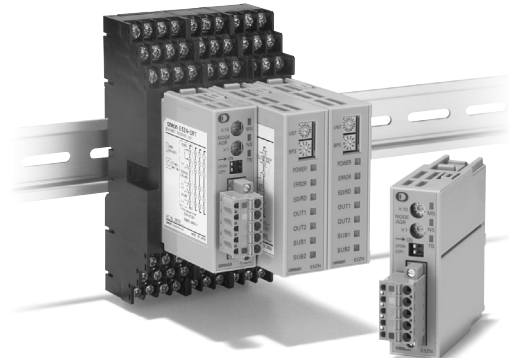

Ordering Information

List of Models

Name	External input power supply voltage	Applicable Temperature Controller	Model
DeviceNet Communications Unit	24 VDC	E5ZN	E5ZN-DRT

Note: A DeviceNet Communications Unit and Terminal Unit are required to connect to DeviceNet. (For details on the Terminal Unit, refer to page 148 or to the E5ZN Catalog (H116-E1-02).) Two End Plates are provided with E5ZN-SCT24S Terminal Units. When mounting to a DIN track, be sure to mount End Plates on both sides.

Specifications

Ratings

Power supply voltage	DeviceNet	24 VDC (for internal circuits)
	External input power supply	24 VDC (for RS-485 communications circuits and Temperature Controllers)
Allowable voltage range	DeviceNet	11 to 25 VDC
	External input power supply	20.4 to 26.4 VDC
Power consumption (See note.)	DeviceNet	Approx. 1.1 W (for a current of 45 mA at 24 VDC)
	External input power supply	Approx. 0.5 W (for a current of 20 mA at 24 VDC)
Connectable Temperature Controllers	E5ZN Series	
Maximum number of connectable Temperature Controllers	16	
Ambient operating temperature	-10 to 55°C (with no icing or condensation)	
Ambient operating humidity	25% to 85%	
Ambient storage temperature	-25 to 65°C (with no icing or condensation)	

Note: The power consumption for the Temperature Controllers is not included.

Temperature Controller

■ Characteristics

Insulation resistance	20 MΩ min. (at 100 VDC)	
Dielectric strength	500 VAC, 50/60 Hz for 1 min between the DIN track and all DeviceNet connector terminals and between the DIN track and all terminal socket terminals	
Vibration resistance	10 to 55 Hz, 10 m/s ² for 2 hrs each in ±X, ±Y, and ±Z directions	
Shock resistance	150 m/s ² , 3 times each in ±X, ±Y, and ±Z directions	
Weight	100 g max.	
Safety standards	cULus508	
	EMS:	Electrostatic Discharge (ESD) EN61006-2, EN61000-4-2 (4 kV/contact, 8 kV/air) Radiated Electromagnetic Fields EN61006-2, EN61000-4-3 (10 V/m) Electrical Fast transients/BURST EN61006-2, EN61000-4-4 (2 kV/DC power-line, 1 kV/Signal-line) Surge Transients EN61006-2, EN61000-4-5 (line to ground : 1 kV/DC power-line : 2 kV/Signal-line line to line : 0.5 kV/DC power-line)
	EMI:	Conducted Disturbances EN61006-2, EN61000-4-6 (10 V) Radiated Emissions (electric field) EN50081-2 Class A

■ Communications (for Temperature Controller Expansion)

Transmission line connection method	RS-485 multipoint
Communications method	RS-485 (2-wire, half-duplex)
Synchronization method	Start-stop synchronization
Baud rate	38,400 bps
Transmission code	ASCII
Data bit length	7 bits
Stop bit length	2 bits
Error detection	Vertical parity (even) BCC (block check character)
Flow control	None
Number of Units that can be connected in parallel	16 Units max. (32 channels)

Connections

■ Terminal Arrangement

E5ZN-DRT

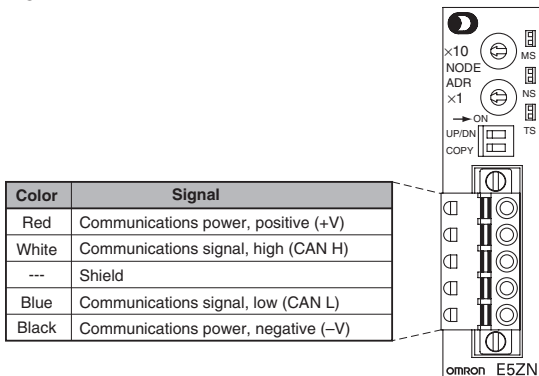

E5ZN-SCT24S

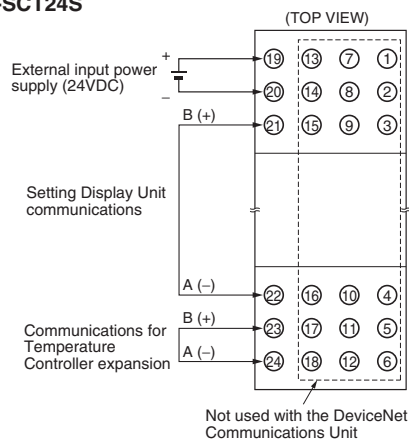

Nomenclature

E5ZN-DRT

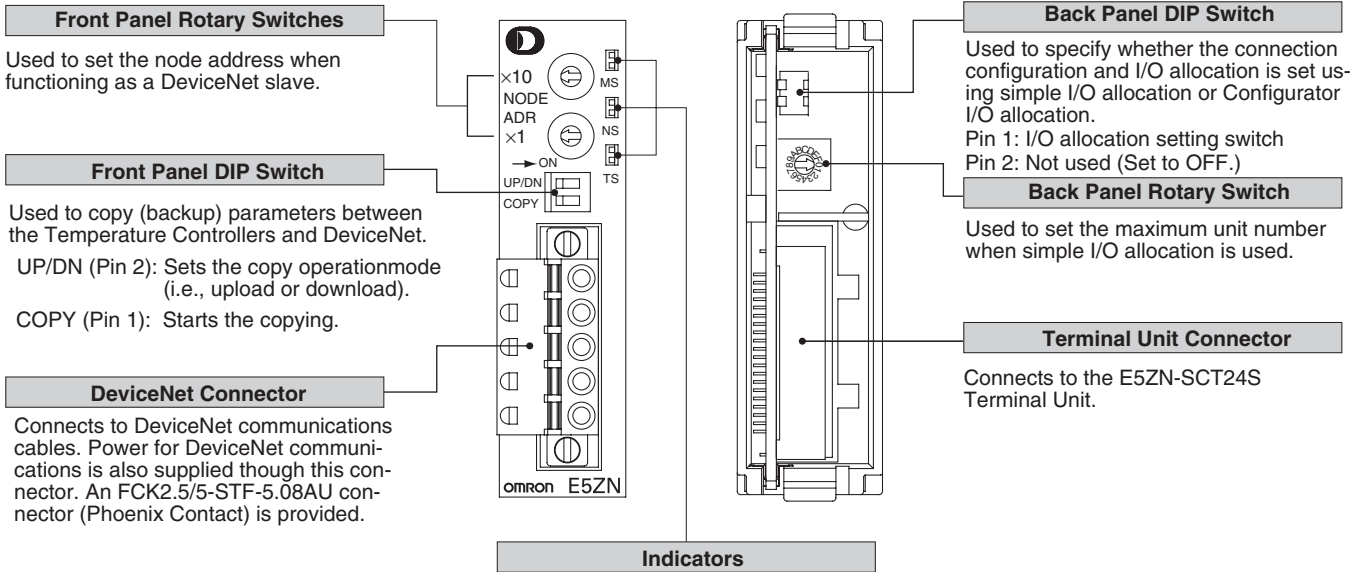

Dimensions

Note: All units are in millimeters unless otherwise indicated.

E5ZN-DRT

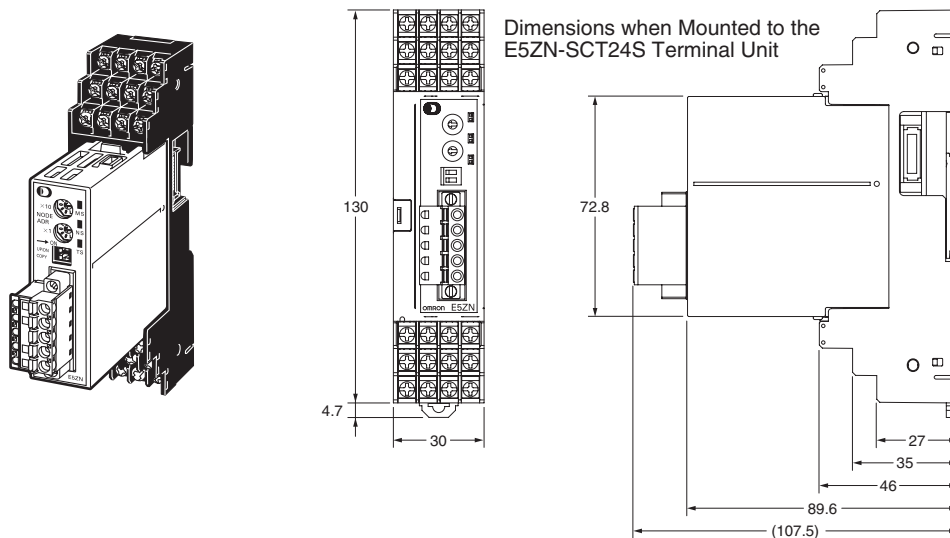

Temperature Controller

E5ZN Modular Temperature Controllers

■ List of Models

Name	Power supply	No. of control points	Control output	Auxiliary output	Functions	Communications functions	Input type (See note 5.)	Model	
Temperature Controller (See note 1.)	24 VDC	2	Voltage output (for SSRs)	Transistor output: 2 pts (sinking)	Heater burnout alarm (See note 3.)	RS-485	Thermocouple	E5ZN-2QNH03TC-FLK	
							Platinum resistance thermometer	E5ZN-2QNH03P-FLK	
							Transistor output: 2 pts (sourcing)	Thermocouple	E5ZN-2QPH03TC-FLK
							Platinum resistance thermometer	E5ZN-2QPH03P-FLK	
			Transistor output	Transistor output: 2 pts (sinking)	Heating or heat/cool control is selectable (See note 4.)		Thermocouple	E5ZN-2TNH03TC-FLK	
							Platinum resistance thermometer	E5ZN-2TNH03P-FLK	
							Transistor output: 2 pts (sourcing)	Thermocouple	E5ZN-2TPH03TC-FLK
							Platinum resistance thermometer	E5ZN-2TPH03P-FLK	
			Analog output (current output) (See note 2.)	Transfer output (linear voltage output) (See note 2.)	Event input: 1 point per Unit		Thermocouple	E5ZN-2CNF03TC-FLK	
								Platinum resistance thermometer	E5ZN-2CNF03P-FLK
								Thermocouple	E5ZN-2CPF03TC-FLK
								Platinum resistance thermometer	E5ZN-2CPF03P-FLK

Note: 1. Terminal Units are required for wiring. Purchase separately.

- When connecting the load of the controlled system, heat control output or cool control output can be allocated to the control output or auxiliary output. When connecting a recording device or Digital Panel Meter, transfer output can be allocated to control output or auxiliary output 3 or 4 of analog output models.
- When using the heater burnout alarm, purchase a Current Transformer (CT) separately.
- When using heating and cooling control functionality, the auxiliary output will be either heating control output or cooling control output.
- Analog input and infrared temperature sensors (ES1A-A) can also be used with thermocouple models.

Name	No. of terminals	Functions	Model
Terminal Unit (Includes bus system without backplane.)	24	Equipped with communications terminals for power supply, communications, and setting devices.	E5ZN-SCT24S-500
	18 (See note 1.)	Not equipped with communications terminals for power supply, communications, and setting devices.	E5ZN-SCT18S-500

Note: 1. When using 2 or more E5ZNs mounted side-by-side, use the E5ZN-SCT18S-500 for the second and subsequent Units. When using E5ZNs separately, be sure to use the E5ZN-SCT24S-500.

- Two End Plates are provided with E5ZN-SCT24S-500 Terminal Units. When mounting to a DIN track, be sure to mount End Plates on both sides.

Setting Display Unit (Order Separately)

Name	Power supply	Model
Setting Display Unit (See note.)	24 VDC	E5ZN-SDL

Note: Purchase sockets for wiring separately.

Warranties, Limitations of Liability

■ WARRANTY

Omron's exclusive warranty is that the products are free from defects in materials and workmanship for a period of one year (or other period if specified) from date of sale by OMRON.

OMRON MAKES NO WARRANTY OR REPRESENTATION, EXPRESS OR IMPLIED, REGARDING NON-INFRINGEMENT, MERCHANTABILITY OR FITNESS FOR PARTICULAR PURPOSE OF THE PRODUCTS. ANY BUYER OR USER ACKNOWLEDGES THAT BUYER OR USER ALONE HAS DETERMINED THAT THE PRODUCTS WILL SUITABLY MEET THE REQUIREMENTS OF THEIR INTENDED USE. OMRON DISCLAIMS ALL OTHER WARRANTIES, EXPRESS OR IMPLIED.

■ LIMITATIONS OF LIABILITY

OMRON SHALL NOT BE RESPONSIBLE FOR SPECIAL, INDIRECT OR CONSEQUENTIAL DAMAGES, LOSS OF PROFITS OR COMMERCIAL LOSS IN ANY WAY CONNECTED WITH THE PRODUCTS, WHETHER SUCH CLAIM IS BASED ON CONTRACT, WARRANTY, NEGLIGENCE OR STRICT LIABILITY.

In no event shall responsibility of Omron for any act exceed the individual price of the product on which liability is asserted.

IN NO EVENT SHALL OMRON BE RESPONSIBLE FOR WARRANTY, REPAIR OR OTHER CLAIMS REGARDING THE PRODUCTS UNLESS OMRON'S ANALYSIS CONFIRMS THAT THE PRODUCTS WERE PROPERLY HANDLED, STORED, INSTALLED AND MAINTAINED AND NOT SUBJECT TO CONTAMINATION, ABUSE, MISUSE, OR INAPPROPRIATE MODIFICATION OR REPAIR.

Application Considerations

■ SUITABILITY FOR USE

OMRON shall not be responsible for conformity with any standards, codes or regulations which apply to the combination of the product in the customer's application or use of the product.

Take all necessary steps to determine the suitability of the product for the systems, machines and equipment with which it will be used.

Know and observe all prohibitions of use applicable to this product.

NEVER USE THE PRODUCT FOR AN APPLICATION INVOLVING SERIOUS RISK TO LIFE OR PROPERTY WITHOUT ENSURING THAT THE SYSTEM AS A WHOLE HAS BEEN DESIGNED TO ADDRESS THE RISKS, AND THAT THE OMRON PRODUCT IS PROPERLY RATED AND INSTALLED FOR THE INTENDED USE WITHIN THE OVERALL EQUIPMENT OR SYSTEM.

Precautions

■ Definition of Precautionary Information

—⚠ WARNING —

Indicates a potentially hazardous situation which, if not avoided, could result in death or serious injury.

—⚠ Caution —

Indicates a potentially hazardous situation which, if not avoided, may result in minor or moderate injury, or property damage.

—⚠ WARNING —

Provide safety measures (such as emergency stop circuits, interlock circuits, and limit circuits) in external circuits in order to ensure safety in the system if an abnormality occurs due to malfunction of the PC or another external factor affecting the PC operation. Not doing so may result in serious accidents.

—⚠ Caution —

Tighten screws to the specified torques given below. Loose screws may result in burning or malfunction.
Connector screws: 0.25 to 0.3 N · m; Terminal screws: 0.40 to 0.56 N · m

Confirm safety at the destination node before transferring a program to another node or changing contents of the I/O memory area. Doing either of these without confirming safety may result in injury.

Execute online edit only after confirming that no adverse effects will be caused by extending the cycle time. Otherwise, the input signals may not be readable.

Do not touch any of the terminals while the power is being supplied. Doing so may result in electric shock.

Do not attempt to take any Unit apart while the power is being supplied. Doing so may result in electric shock.

Do not allow metal fragments or lead wire scraps to fall inside this product. These may cause electric shock, fire, or malfunction.

Notice

Observe the following points to ensure safe operation.

- Set the communications distance to within the range specified in the E5ZN-DRT User's Manual (Cat. No. H119).
- Do not place communications cables close to or parallel to high-voltage lines or power lines.
- Use the communications cables specified in the E5ZN-DRT User's Manual (Cat. No. H119).
- Do not attempt to disassemble, repair, or modify the product.
- Do not drop the product or expose it to excessive shocks or vibrations. Doing so may result in malfunctions.
- Always use the power supply voltage within the specified range.
- Do not pull on the cables or bend the cables beyond their natural limit.
- Confirm that the power is OFF before wiring.
- Be sure to perform wiring for communications lines and power supplies correctly. Be sure to wire to terminals with the correct polarity. Incorrect wiring may result in malfunctions.
- Confirm that the power is OFF before mounting or removing connectors. Mounting or removing connectors with the power ON may result in malfunctions.
- Double-check all wiring and switch settings before turning ON the power supply.

Notice

- Do not use the product in the following locations
 - Locations exposed to direct sunlight
 - Locations subject to intense temperature changes
 - Locations subject to freezing or condensation
 - Locations subject to dust or corrosive gases (in particular, sulfide gas and ammonia gas)
 - Locations subject to exposure to water or oil
 - Locations subject to vibrations or shocks
- Take appropriate and sufficient countermeasures when installing systems in the following locations:
 - Locations subject to static electricity or other forms of noise.
 - Locations subject to strong electromagnetic fields.
 - Locations subject to possible exposure to radioactivity.
 - Locations close to power lines with high voltage or large current.
- Use the product within the specified temperature and humidity ranges.
- Take appropriate measures to ensure that the specified power with the rated voltage and frequency is supplied in places where the power supply is unstable.
- Do not use solvents to clean the product.
- Confirm that the power is OFF before replacing the product.

ALL DIMENSIONS SHOWN ARE IN MILLIMETERS.
--

To convert millimeters into inches, multiply by 0.03937. To convert grams into ounces, multiply by 0.03527.
