

**NT21**

# **Programmable Terminal**

## **Setup Manual**

**OMRON**

# NT21 Programmable Terminal

## Setup Manual

*Produced October 2001*

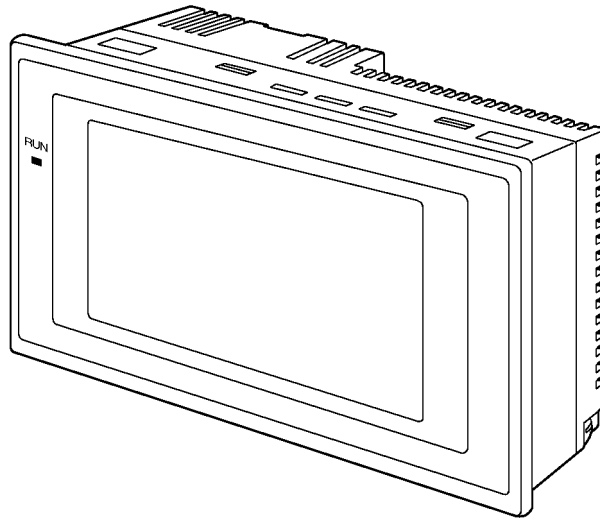

# TABLE OF CONTENTS

<b>PRECAUTIONS</b> .....	<b>xi</b>
1 Intended Audience .....	xii
2 General Precautions .....	xii
3 Safety Precautions .....	xii
<b>SECTION 1</b>	
<b>General</b> .....	<b>1</b>
1-1 Role and Operation of the NT21 .....	2
1-2 Comparison between NT20S and NT21 .....	4
1-3 System Configuration .....	6
1-4 Before Operating .....	7
<b>SECTION 2</b>	
<b>Preparing for Connection</b> .....	<b>9</b>
2-1 Method for Connection to the Host .....	10
2-2 Names and Functions of Parts .....	13
<b>SECTION 3</b>	
<b>Hardware Installation and Connections</b> .....	<b>15</b>
3-1 Installation .....	16
3-2 Connecting Link Adapters .....	18
3-3 Connecting the NT Support Tool .....	28
3-4 Connecting a Bar Code Reader .....	29
3-5 Using a Memory Unit .....	31
<b>SECTION 4</b>	
<b>Connecting to the Host from the RS-232C Port</b> .....	<b>39</b>
4-1 Connecting to the RS-232C Port at the Host .....	40
<b>SECTION 5</b>	
<b>Connecting to the Host from the RS-422A/485 Port</b> ....	<b>67</b>
5-1 Connecting to the Host's RS-422A/485 Port .....	68
5-2 Connecting to the Host's RS-232C Port .....	94
<b>SECTION 6</b>	
<b>System Menu Operation</b> .....	<b>101</b>
6-1 System Menu Operation Flow .....	103
6-2 Starting the NT21 .....	104
6-3 Operation Modes and the System Menu .....	105
6-4 Memory Initialization .....	110
6-5 Operations in the System Installer Mode .....	118
6-6 Transmitting the Screen Data .....	123
6-7 Setting Conditions for Communications with Host by Using Memory Switches .....	125
6-8 Starting Operation .....	133
6-9 System Settings .....	134
6-10 Setting the Bar Code Reader Input Function .....	144
6-11 System Maintenance .....	147
6-12 Programming Console Function .....	165
6-13 Version Display .....	171

# TABLE OF CONTENTS

## SECTION 7

### **Troubleshooting and Maintenance . . . . . 173**

7-1 Troubleshooting . . . . .	174
7-2 Responding to Displayed Error Messages . . . . .	176
7-3 Maintenance of the NT21 . . . . .	183
7-4 Inspection and Cleaning . . . . .	185

### **Appendices**

A Specifications . . . . .	187
B External Dimensions and Mounting Dimensions . . . . .	193
C Transporting and Storing the NT21 . . . . .	195
D Making the Cable . . . . .	197
E Making the Cable for Connecting a Personal Computer . . . . .	199
F Model List . . . . .	201
G Option List . . . . .	207

### **Index . . . . . 209**

### **Revision History . . . . . 213**





## Notice:

OMRON products are manufactured for use according to proper procedures by a qualified operator and only for the purposes described in this manual.

The following conventions are used to indicate and classify precautions in this manual. Always heed the information provided with them. Failure to heed precautions can result in injury to people or damage to property.

 **DANGER** Indicates an imminently hazardous situation which, if not avoided, will result in death or serious injury.

 **WARNING** Indicates a potentially hazardous situation which, if not avoided, could result in death or serious injury.

 **Caution** Indicates a potentially hazardous situation which, if not avoided, may result in minor or moderate injury, or property damage.

## OMRON Product References

All OMRON products are capitalized in this manual. The word “Unit” is also capitalized when it refers to an OMRON product, regardless of whether or not it appears in the proper name of the product.

The abbreviation “Ch,” which appears in some displays and on some OMRON products, often means “word” and is abbreviated “Wd” in documentation in this sense.

The abbreviation “PC” means Programmable Controller and is not used as an abbreviation for anything else.

## Visual Aids

The following headings appear in the left column of the manual to help you locate different types of information.

**Note** Indicates information of particular interest for efficient and convenient operation of the product.

**1, 2, 3...** 1. Indicates lists of one sort or another, such as procedures, checklists, etc.

## © OMRON, 2001

All rights reserved. No part of this publication may be reproduced, stored in a retrieval system, or transmitted, in any form, or by any means, mechanical, electronic, photocopying, recording, or otherwise, without the prior written permission of OMRON.

No patent liability is assumed with respect to the use of the information contained herein. Moreover, because OMRON is constantly striving to improve its high-quality products, the information contained in this manual is subject to change without notice. Every precaution has been taken in the preparation of this manual. Nevertheless, OMRON assumes no responsibility for errors or omissions. Neither is any liability assumed for damages resulting from the use of the information contained in this publication.



## About this Manual:

This manual describes connecting the NT-series NT21 Programmable Terminal to a PC (Programmable Controller) or other host and peripheral devices and the settings required for communications and applications. It includes the sections described below.

Please read this manual carefully and be sure you understand the information provided before attempting to install and operate the Programmable Terminal.

**Section 1** provides fundamental information about the functions and features of the PTs, types of connection, communication methods, etc. This information will enable you to understand the applications of the PTs.

**Section 2** describes the connection methods that are possible with the PTs, and the functions of the parts of PTs, as the required knowledge before connecting to the host and to the peripheral devices.

**Section 3** describes the settings of the PTs and methods for connection to peripheral devices.

**Section 4** describes the method for connecting to the host using the RS-232C port of the PT.

**Section 5** describes the method for connecting to the host using the RS-422A/485 port of the PT.

**Section 6** describes the operation of the System Menu, focusing on the procedure to start the PT. Functions that are convenient when using the PT and those that are useful for system maintenance are also explained here.

**Section 7** describes the action to take when errors occur in the PT, and how to carry out maintenance and inspection to prevent the occurrence of errors.

The **Appendices** provide specifications, dimensions, procedures for transporting and storing the PT, information on cable preparation, information on the relationship between the system program and hardware, and product lists.



**WARNING** Failure to read and understand the information provided in this manual may result in personal injury or death, damage to the product, or product failure. Please read each section in its entirety and be sure you understand the information provided in the section and related sections before attempting any of the procedures or operations given.



## ***Related Manuals:***

Related manuals are listed below.

The □ symbol at the end of the catalog number is the revision number.

### **Connecting and Setting Up the Programmable Terminal**

- NT21 PT Setup Manual (V068-E1-□, this manual)

This manual describes connecting the Programmable Terminals to a host and peripheral devices and settings required for communications and applications.

The functions and actual operating methods for the NT21 are provided in the *Reference Manual* (V069-E1-□).

### **Programmable Terminal Functions and Operation**

- NT21 PT Reference Manual (V069-E1-□)

This manual is used for NT21 PT. It describes screen configurations, part functions, host control methods, and other application information.

PT connection and setup procedures are described in the *NT21 PT Setup Manual* (V068-E1-□).

### **Creating and Transferring Screen Data, and Installing the System Program**

- NT-series Support Tool for Windows Ver. 4.6 Operation Manual (V061-E1-□)

The screens displayed on the NT21 are created with the NT Support Tool and transferred to the PT. This manual describes how to create and transfer screen data. It also describes how to download a system program to a PT using the System Installer.

The NT-series Support Tool for Windows is normally referred to as merely the NT Support Tool.

### **Faulty Display Pixels**

Although the LCD panel has been manufactured with extremely high-level technology, there can sometimes be pixels that will not light or that will be lit constantly. These are characteristic of LCD panels and are not an indication of a faulty display. Please understand that, although we are constantly striving to keep these pixels to a minimum, it is not possible with present technology to eliminate them completely.

# PRECAUTIONS

This section provides general precautions for using the Programmable Terminal.

**The information contained in this section is important for the safe and reliable application of the Programmable Terminal. You must read this section and understand the information contained before attempting to set up or operate a Programmable Terminal.**

1 Intended Audience .....	xii
2 General Precautions .....	xii
3 Safety Precautions .....	xii

## 1 Intended Audience

This manual is intended for the following personnel, who must also have knowledge of electrical systems (an electrical engineer or the equivalent).

- Personnel in charge of introducing FA systems into production facilities.
- Personnel in charge of designing FA systems.
- Personnel in charge of installing and connecting FA systems.
- Personnel in charge of managing FA systems and facilities.

## 2 General Precautions

The user must operate the product according to the performance specifications described in the operation manuals.

Before using the product under conditions that are not described in the manual or applying the product to nuclear control systems, railroad systems, aviation systems, vehicles, combustion systems, medical equipment, amusement machines, safety equipment, and other systems, machines and equipment that may have a serious influence on lives and property if used improperly, consult your OMRON representative.

Make sure that the ratings and performance characteristics of the product are sufficient for the systems, machines, and equipment, and be sure to provide the systems, machines, and equipment with double safety mechanisms.

This manual provides information for using the Programmable Terminal. Be sure to read this manual before attempting to use the software and keep this manual close at hand for reference during operation.

 **WARNING** It is extremely important that Programmable Terminals and related devices be used for the specified purpose and under the specified conditions, especially in applications that can directly or indirectly affect human life. You must consult with your OMRON representative before applying Programmable Terminals to the above-mentioned applications.

 **WARNING** Do not use input functions such as PT touch switches for applications where danger to human life or serious damage is possible, or for emergency switch applications.

## 3 Safety Precautions

Read these safety precautions carefully and make sure you understand them before using the Programmable Terminal so that you can use it safely and correctly.

### Safety Conventions and their Meanings

This operation manual uses the following conventions and symbols to indicate cautions, warnings, and dangers in order to ensure safe use of the NT21.

The cautions, warnings, and dangers shown here contain important information related to safety. The instructions in these cautions, warnings, and dangers must be observed.

The conventions used and their meanings are presented below.

 **WARNING** Indicates information that, if not heeded, could possibly result in loss of life or serious injury.

**Caution** Indicates information that, if not heeded, could result in relatively serious or minor injury, damage to the product, or faulty operation.



**WARNING**

Do not attempt to take the Unit apart and do not touch any internal parts while the power is being supplied. Doing either of these may result in electrical shock.



# SECTION 1

## General

This section provides fundamental information about the functions and features of the PTs, types of connection, communication methods, etc. This information will enable you to understand the applications of the PTs.

1-1	Role and Operation of the NT21 .....	2
1-1-1	Operation of an NT21 at an FA Production Site .....	2
1-1-2	Operations of the NT21 .....	3
1-2	Comparison between NT20S and NT21 .....	4
1-3	System Configuration .....	6
1-3-1	Peripheral Devices That Can Be Connected .....	6
1-3-2	Connecting to the Host .....	7
1-4	Before Operating .....	7

# 1-1 Role and Operation of the NT21

The NT21 is a sophisticated operator interface (Programmable Terminal) that automatically displays information and can also be used for operations when necessary. The following gives a general description of the role and operation of the NT21 for those using a Programmable Terminal (PT) for the first time.

## 1-1-1 Operation of an NT21 at an FA Production Site

### Production Line Status Monitoring

The NT21 displays real-time information about the system and equipment operating status, etc. Its power of expression is enhanced by graphs and other visuals, making the displays easy to understand.

Production Control (3)	
Product	NT21
Today's target	560
Current production	305
Number defective	2
Number repaired	7
% achieved NT21      5%	

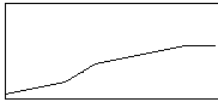

### Directions to Workers on the Shop Floor

The NT21 warns of system or equipment failures and prompts the appropriate remedial action.

Alarm

Assembly line B

Positioning pin

is defective. Line stopped.





Check the following.

1. Defective pin L3
2. Position of dog M2
3. Mounting of photosensor P5

### Panel Switch Functions

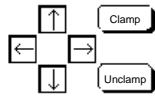
Setting touch switches on the NT21 allows workers to use the NT21 as an operating panel; the results of the operations are transmitted to the host.

Electroplating control

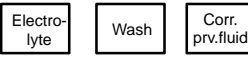
Transport 	Electr. head Wash. head Corr. prv. head 	
		

### 1-1-2 Operations of the NT21

#### Transfers Screen Data

The screen data to be displayed on the NT21 can be created on a personal computer using the NT Support Tool. Connect the NT21 to the personal computer with an RS-232C cable and transfer the screen data to the NT21.

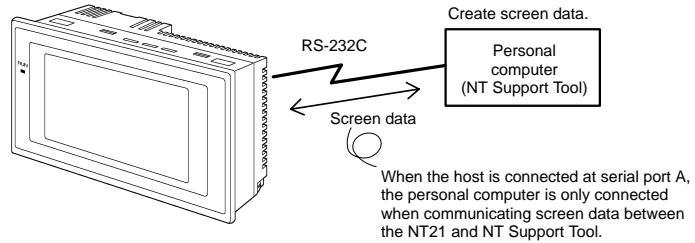

#### Displays Screens

The information to be displayed (screen data) can be created on a computer using the NT Support Tool and stored in the NT21. The screen data can be displayed on the NT21 in response to commands from the host or touch switch operation.

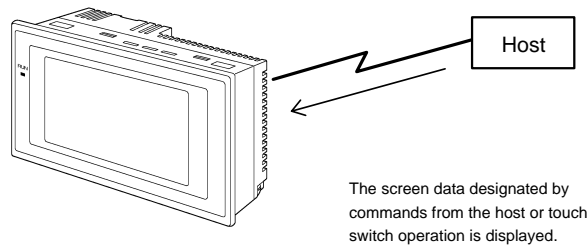

#### Receives Data from a Host

The NT21 can be connected to the host by a Host Link or NT link and receive necessary data from the host.

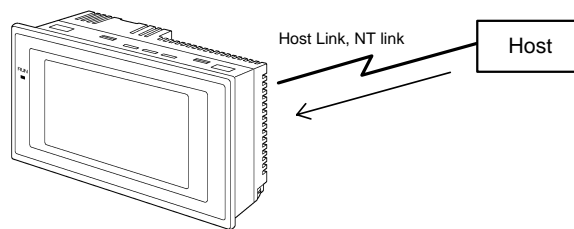

#### Sends Data to a Host

Data inputs (switch ON/OFF statuses, numeric values, character strings) that were input with devices such as touch switches can be transmitted to the host.

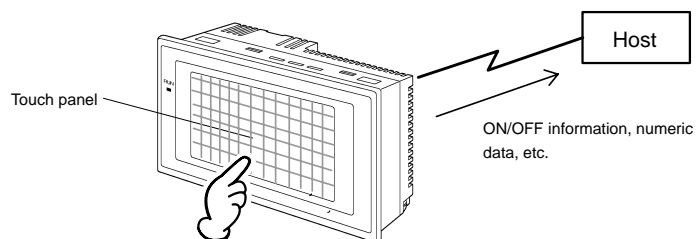

## 1-2 Comparison between NT20S and NT21

Item	NT20S	NT21
NT Support Tool used	NT-ZJCAT1-EV4 or NT-ZA3AT-EV2	NT-ZJCAT1-EV4.6
Effective display area	112 x 56 mm (horizontal x vertical)	117 x 63 mm (horizontal x vertical)
Number of screen dots (resolution)	256 x 128 dots (horizontal x vertical)	260 x 140 dots (horizontal x vertical)
Number of touch switches	12 x 6 dots (horizontal x vertical)	13 x 7 dots (horizontal x vertical)
DIP switch settings	On rear of Unit	None (software settings)
Use of Memory Unit	Not possible	Possible (to transfer system program data and screen data)
RS-232C interface	Connector (9-pin) also used as port for screen data transfer	- Port A connector (also used for screen data transfer, 9-pin) - Port B connector (for host communications only, 9-pin)
Backlight life	10,000 h min.	50,000 h min.
Replacement backlight	NT20S-CFL01	Not replaceable.
Battery backup	Not possible	Possible*1 (numeral/character string memory tables, history data, recipe data, and clock data)
System program data	Pre-installed (cannot be changed)	The system installer and system program data are transferred from the NT Support Tool.
1:N NT Links	Standard	Standard or high-speed
Memory Links	Not possible*2	Possible
Number of user-registered screens	Maximum of 500	Maximum of 3999
Screen data capacity*3 (User program memory)	96 KB	512 KB
Numeral and character string memory tables	Maximum of 128 entries	Maximum of 2,000 entries
Bit memory table	None	Maximum of 1000 bits
Mathematical table	None	256 entries max. Calculations can be executed automatically in the PT.
Image data	None	Maximum of 4,095 (224 in NT20S-compatible mode)
Library data	None	Maximum of 12,288 (896 in NT20S-compatible mode)
Fixed graphics (rectangles, polygons, arcs, sectors, tiling)	None	65,535 per screen including all fixed display elements
Image library display	None	256 per screen max.
Analog meters	None	50 per screen max.
Trend graphs	None	1 per screen max.
Broken-line graphs	None	1 per screen max.
Alarm list/history	None	4 per screen max.
Recipes	None	1 per screen max.
Windows	None	Maximum of 3
Method for storing numeric values (numeral memory data and PT Status Control Area)	Fixed as BCD (binary coded decimal)	Selectable from BCD (binary coded decimal) or binary
PT Status Control Area size	4 words	5 words (partial change of contents) (4 words in NT20S-compatible mode)



Item	NT20S	NT21
PT Status Notify Area size	3 words	2 words (partial change of contents) (3 words in NT20S-compatible mode)
Window Control Area size	None	9 words
Clock Data Area size	None	4 words
Registering continuous screen	Possible	Not possible (Use a screen switchover as a substitute.)
System tenkey	Possible	Not possible (Use the normal tenkey as a substitute.)
Lamp/Touch switch labels	Fixed display (1 line only)	<ul style="list-style-type: none"> <li>- Multiple lines can be displayed</li> <li>- ON/OFF switching is possible</li> <li>- Numeral display is possible</li> <li>- Character string display is possible</li> </ul>
Interlock function	None	Operations can be disabled from the PC by allocating interlock bits to the corresponding touch switch, numeral input, character string input, thumbwheel switch, or recipe.
Programming Console function	Not possible	Possible
Bar code reader connection	Not possible	Possible
High-resolution fonts	Not possible	Possible
Applicable character codes	CP437 (equivalent to English DOS)	CP437 (equivalent to English DOS) or ISO8859/1 (equivalent to English Windows)
Accessible CS/CJ PC data Areas	---	<p>The data Areas listed below can be accessed in addition to the data Areas accessible with the NT30/NT30C.*4</p> <ul style="list-style-type: none"> <li>- EM banks (EM_0 to EM_C)</li> <li>- Timer completion flags (TU)</li> <li>- Counter completion flags (CU)</li> <li>- Work Areas (WR)</li> <li>- Task flags (TK)</li> <li>- HR Area</li> </ul>

\*1: The Battery is optional.

\*2: An RS-232C command system is supported instead (NT20S-ST128 only)

\*3: The capacity of the flash memory that stores image data.

\*4: Only when communicating with a CS/CJ-series PC on a 1:N NT Link. (Access is not possible via a Host Link.)

# 1-3 System Configuration

This section shows the configuration of a system that uses an NT21. For details on product models, refer to *Appendix F Model List* (page 201).

## 1-3-1 Peripheral Devices That Can Be Connected

The following peripheral devices can be connected to an NT21.

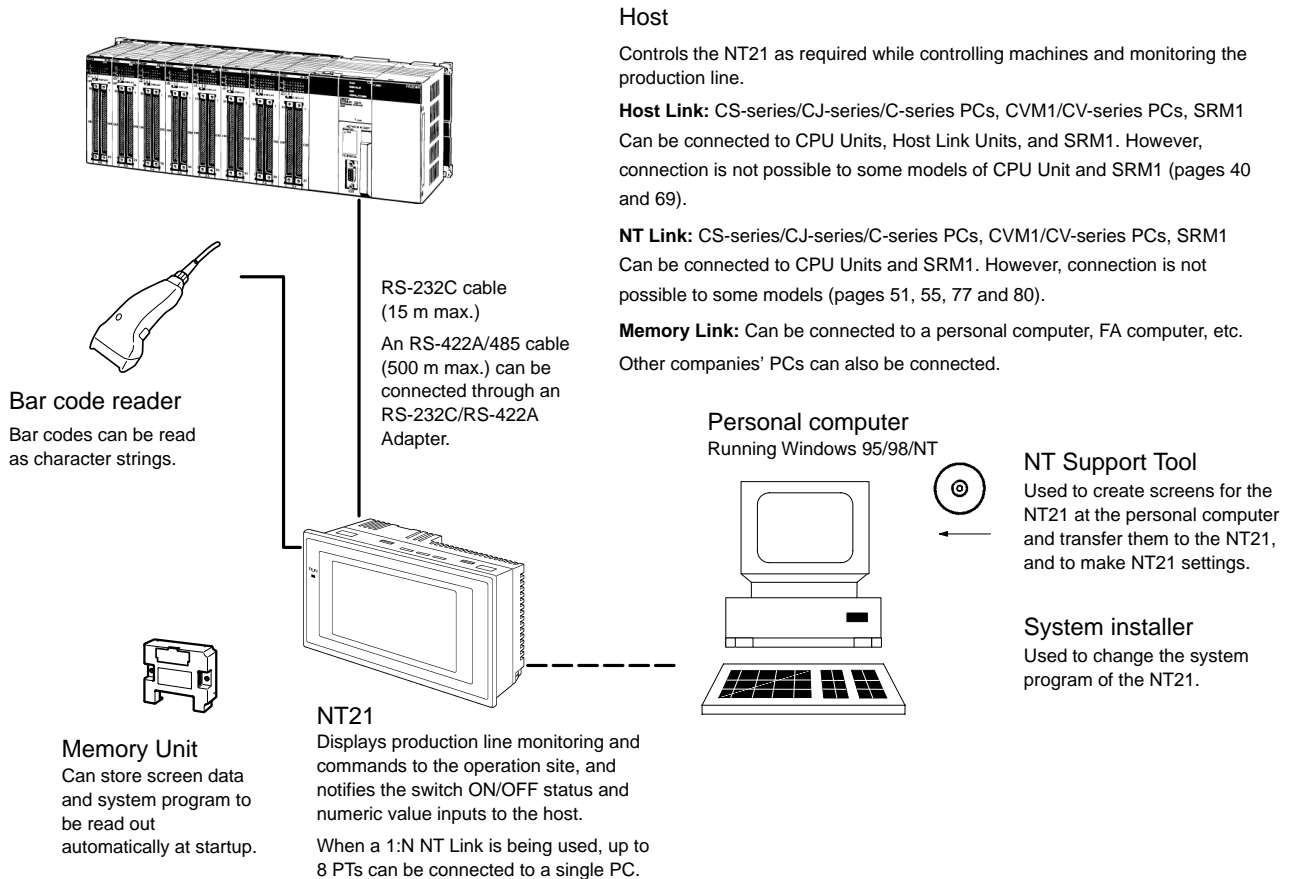

- Bar code reader (page 29)
- Memory Unit (page 31)  
NT-MF261 (made by OMRON)
- NT Support Tool (page 28)  
NT-series Support Tool Version 4.6 for Windows (Made by OMRON)
  - NT-ZJCAT1-EV4.6 (CD-ROM version for IBM PC/AT and compatible computers)
- System installer (page 28)  
System Installer (made by OMRON)  
The System Installer is supplied as a standard accessory with the NT Support Tool (NTZJCAT1-EV4.6).

**Reference:** The following optional devices are available.

Reflection-suppressing Protective Sheets (5)	NT20S-KBA04
Chemical-resistant cover	NT20S-KBA01
Battery	3G2A9-BAT08

### 1-3-2 Connecting to the Host

The NT21 has the following two communication ports.

- Serial port A:  
D-SUB 9-pin connector (female)

For RS-232C only (The NT Support Tool and bar code readers can be connected here, but an NS-AL002 Link Adapter cannot be connected.)

- Serial port B:  
D-SUB 9-pin connector (female)

For RS-232C only (The NT Support Tool and bar code readers cannot be connected here, but an NS-AL002 Link Adapter can be connected.)

The host can be connected at either of these two ports.

## 1-4 Before Operating

Follow the procedure given below to start the system of the NT21.

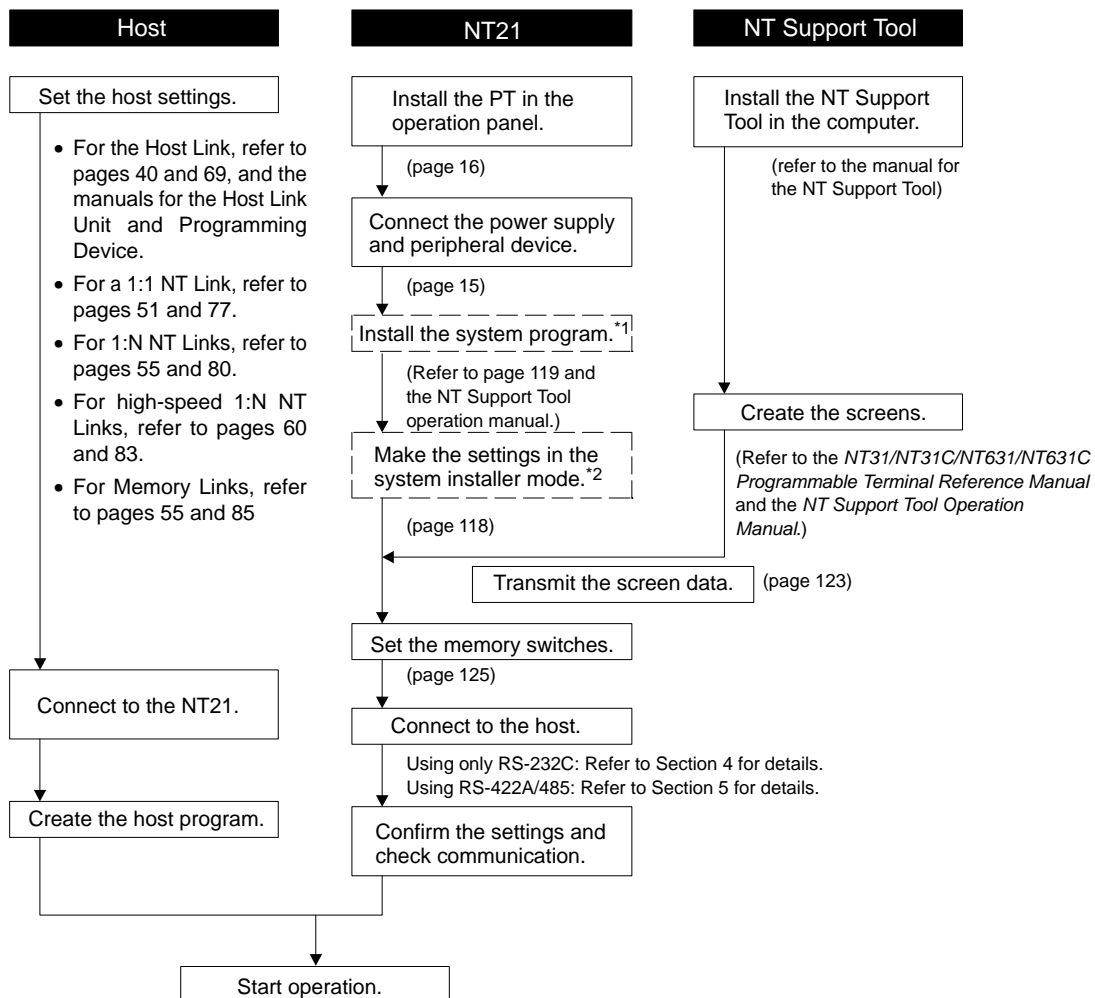

\*1: System program installation is only done in special circumstances, for example when changing the system program, or when recovering the original status of the installed program. This operation is not normally necessary.

\*2: Display of the system menu, and all change operations, can be inhibited. This enables you to prevent the accidental deletion or alteration of screens and settings.

- Reference:**
- For the system program, use the NT21 system program supplied as an accessory with the NT-series Support Tool (NT-ZJCAT1-EV4.6).
  - For the NT Support Tool, use NT-series Support Tool for Windows (Ver. 4.6).
- Refer to the following manuals for the devices and software.

Device or Software	Manual Title	Cat. No.
NT21 NT31/NT31C, NT631/NT631C	Reference Manual	V069-E1-□
System Installer	NT-series Support Tool for Windows (Ver. 4.6) Operation Manual	V061-E1-□
NT Support Tool	NT-series Support Tool for Windows (Ver. 4.6) Operation Manual	V061-E1-□
PC	SYSMAC CPM1 Operation Manual	W262-E1-□
	SYSMAC CPM1A Operation Manual	W317-E1-□
	SYSMAC CPM2A Operation Manual	W352-E1-□
	SYSMAC CPM2C Operation Manual	W356-E1-□
	SYSMAC C200H Operation Manual (for CPU01/03/11) (Programming)	W130-E1-□
	SYSMAC C200H Operation Manual (for CPU21/23/31) (Programming)	W217-E1-□
	SYSMAC C200HS Installation Guide	W236-E1-□
	SYSMAC C200HS Operation Manual (Programming)	W235-E1-□
	SYSMAC C200HX/HG/HE (-Z) Installation Guide	W302-E1-□
	SYSMAC C200HX/HG/HE Operation Manual	W303-E1-□
	SYSMAC C200HX/HG/HE-Z Operation Manual	W322-E1-□
	SYSMAC CQM1/CPM1/CPM1A/SRM1 Programming Manual	W228-E1-□
	SYSMAC CQM1H Operation Manual	W363-E1-□
	SYSMAC CVM1/CV500/CV1000/CV2000/CVM1 Operation Manual: Ladder Diagrams	W202-E1-□
	CS Series Programmable Controllers Operation Manual	W339-E1-□
	CJ Series CJ1G-CPU□□-E Programmable Controllers Operation Manual	W393-E1-□
	CS/CJ Series Programming Manual	W394-E1-□
	CS/CJ Series Serial Communications Boards/Units Operation Manual	W336-E1-□
SYSMAC CQM1H Series Serial Communications Board Operation Manual	W365-E1-□	
CompoBus Master Control Unit	SRM1 (-V2) Operation Manual	W318-E1-□
Programming Tools	SYSMAC Support Software Operation Manual: C-series PCs	W248-E1-□
	SYSMAC Support Software Operation Manual: CVM1 PCs	W249-E1-□
	SYSMAC CPT User Manual and Quick Start Guide	W332-E1-□ W333-E1-□
	CX-Programmer User Manual	-
Host Link Unit/ Serial Communications Board	SYSMAC C Series Host Link Unit System Manual	W143-E1-□
	SYSMAC CVM1/CV Series Host Link Operation Manual	W205-E1-□
	SYSMAC C200HW-COM01 C200HW-COM02-V1 to C200HW-COM06-EV1 Communications Board Operation Manual	W304-E1-□

# SECTION 2

## Preparing for Connection

This section describes the connection methods that are possible with the PTs, and the functions of the parts of PTs, as the required knowledge before connecting to the host and to other devices.

2-1	Method for Connection to the Host .....	10
2-2	Names and Functions of Parts .....	13

## 2-1 Method for Connection to the Host

This section describes the methods for connection to the host used with the NT21, and the relationship between the connection method and the communication method.

### **NT21 Communication Ports and Communication Methods**

The NT21 has two communication ports. Their uses are indicated in the table below.

Communication Port	Usable Communication Methods	Communications
Serial port A	Host Link 1:1 NT Link 1:N NT Link* Memory Link (NT Support Tool connection) (Bar code reader input function)	RS-232C
Serial port B	Host Link 1:1 NT Link 1:N NT Link* Memory Link	RS-232C

\* There are two 1:N NT Link communications rates: standard and high-speed.

### **Communication Methods That Can Be Used with the Host**

The following communication methods can be used with the hosts that can be connected to the NT21.

- RS-232C
- RS-422A
- RS-485

The communications types that are actually supported vary with the host. For details, refer to *Section 4 Connecting to the Host from the RS-232C Port* and *Section 5 Connecting to the Host from the RS-422A/485 Port*.

### **Converting Communication Type with the RS-232C/RS-422A Link Adapter**

An OMRON NT-AL001-E or NS-AL002-E Link Adapter can be used convert from RS-232C communications to either RS-422A or RS-485.

- RS-232C ⇔ RS-422A
- RS-232C ⇔ RS-485

There are two models of Link Adapters available with different features:

- NT-AL001 Link Adapter  
The RS-232C port is insulated from the RS-422A/485 terminals. An RS-232C cable (2 m max.) can be connected to either serial port A or B on the NT21.
- NS-AL002 Link Adapter  
The RS-232C port is **not** insulated from the RS-422A/485 terminals. The NS-AL002 Link Adapter can be connected directly to serial port B on the NT21. (The NS-AL002 cannot be connected directly to serial port A on the NT21.)

**Combinations of Communication Method and Connection Method**

The connection methods that can be used depending on the communication method used and the communications type for communication between the NT21 and the host are indicated in the table below.

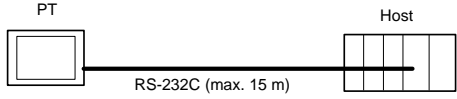
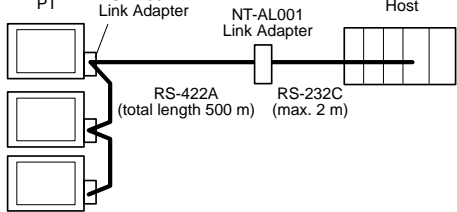
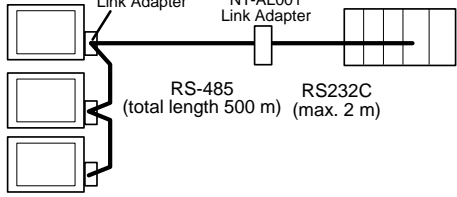
Communication type at Host	Usable Connection Method	Usable Communication Method				Details
		Host Link	1:1 NT Link	1:N NT Link	Memory link	
RS-232C	Direct 1:1 connection 	○	○	○	○	63
RS-232C	1:N connection with RS-422A through Link Adapters 	×	×	○	×	95
RS-232C	1:N connection with RS-485 through Link Adapters 	×	×	○	×	95

○: Connection possible    ×: Connection not possible

**Note** \*An RS-232C Cable (not shown in the diagram) is required when connecting an NT-AL001 Link Adapter to a PT.

Communication type at Host	Usable Connection Method	Usable Communication Method				Details
		Host Link	1:1 NT Link	1:N NT Link	Memory link	
RS-422A	Direct 1:1 connection with RS-422A through a Link Adapter 	○	○	○	○	85
RS-485	Direct 1:1 connection with RS-485 through a Link Adapter 	×	×	○	×	88
RS-422A	1:N connection with RS-422A through Link Adapters 	×	×	○	×	89
RS-485	1:N connection with RS-485 through Link Adapters 	×	×	○	×	92

○: Connection possible    ×: Connection not possible

**Note** \*An RS-232C Cable (not shown in the diagram) is required when connecting an NT-AL001 Link Adapter to a PT.

- The NT-AL001 Link Adapter requires a +5-V, 150 mA power supply at pin 6 of the RS-232C connector. When the NT-AL001 is being connected to the NT21, a 5-V power supply is output from pin 6 of serial port A or B in the NT21. Connect pin 6 of the Link Adapter's RS-232C connector with pin 6 of the NT21's RS-232C connector.  
When the NT-AL001 is being connected to a host and power is not supplied from the host's port, connect an external power supply to pins 6 and 9 of the Link Adapter's RS-232C connector. Connect the +5-V line to pin 6 and the SG line to pin 9.
- Never connect or disconnect cables or Units to an NT-AL001 or NS-AL002 while the power is ON. Be sure to turn OFF the power supply of the NT21 or host before connecting or disconnecting the cables.
- A +5-V power supply is output from pin 6 of serial ports A and B in the NT21. It is possible to use the power from both ports simultaneously, but the maximum capacity is 150 mA max. total. Do not exceed 150 mA total output.
- When using RS-422A or RS-485 communications, it is convenient to use an NS-AL002 Link Adapter and make a direct connection to serial port B of the NT21. However, there is no insulation between the NS-AL002's RS-232C port and RS-422A/RS-485 port.



## 2-2 Names and Functions of Parts

Before starting operation, the names and functions of the parts of the NT21 are described here as a confirmation. A method of hardware settings is also described.

### Front View

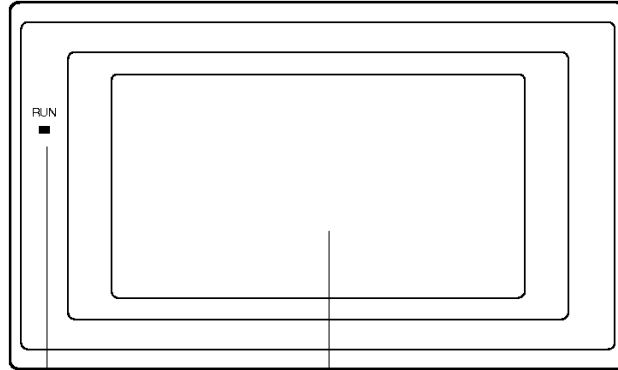

**RUN Indicator**

- Lit in green while the NT21 is in the RUN mode.
- Lit in orange or red when the battery is low (orange in the RUN mode, red in other modes).

**Display**

Monochrome LCD screen with backlight  
The whole area of the screen is a touch panel that works as an input device.

**Reference:** The NT21 comes in two body colors.

NT21	Body Color
NT21-ST121-E	Beige
NT21-ST121B-E	Black

Rear View

Expansion interface connector  
When using an Expansion Interface Unit such as a Memory Unit, connect it here.

Battery cover  
There is a battery holder beneath this cover. The battery is optional (sold separately) and is not installed when the NT21 is shipped.

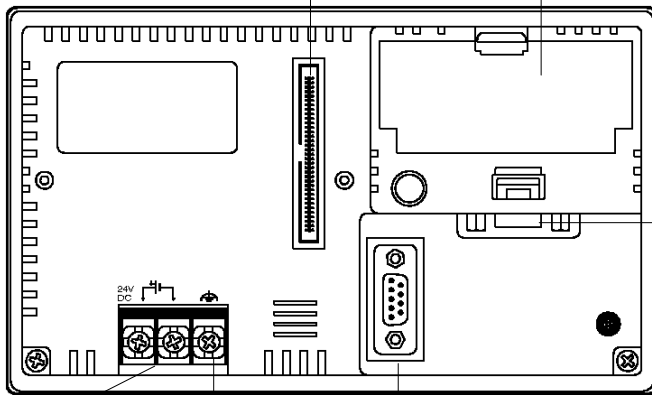

Serial port B connector  
Connect the cable for connection to the host here. An NS-AL002 Link Adapter can be connected directly to this port. This is a 9-pin connector for RS-232C only.

Power input terminals  
Connect the power to the NT21 at these terminals.

GR terminal  
Grounding terminal to prevent malfunction due to noise.

Serial port A connector  
Connect the cable for connection to the host or NT Support Tool here. A bar code reader can also be connected here. This is a 9-pin connector for RS-232C only.

**Note** Before turning the power ON/OFF, confirm system safety, otherwise the system may operate unpredictably.

# SECTION 3

## Hardware Installation and Connections

This section describes the installation of the PTs and methods for connection to other devices.

For details on connecting to the host, refer *Section 4 Connecting to the Host from the RS-232C Port* or *Section 5 Connecting to the Host from the RS-422A/485 Port*.

3-1	Installation	16
3-1-1	Installation Environment	16
3-1-2	Installation in the Operation Panel	16
3-1-3	Power Supply Connection	17
3-1-4	Grounding	18
3-2	Connecting Link Adapters	18
3-2-1	Connecting an NS-AL002 Link Adapter	18
3-2-2	Connecting an NT-AL001 Link Adapter	22
3-3	Connecting the NT Support Tool	28
3-4	Connecting a Bar Code Reader	29
3-4-1	Connection Method	29
3-4-2	Setting a Bar Code Reader	29
3-4-3	Data Format	30
3-5	Using a Memory Unit	31
3-5-1	Installation Method	32
3-5-2	Method of Use	32

**Note** On unpacking the NT21 check the external appearance and confirm that there is no damage. Also confirm that there is no abnormal noise on shaking the PT lightly.

## 3-1 Installation

Install the NT21 in the operation panel and connect the power to the NT21 as described below.

### 3-1-1 Installation Environment

Observe the following points when installing the PT in an operation panel.

- Note**
1. Do not install the NT21 at sites subject to the following conditions. Otherwise the product may malfunction.
    - Severe temperature variations
    - Temperatures or humidities outside the ranges stated in the specifications
    - High humidity, condensation
    - Splashing chemical agents
    - Severe oil splashing
    - Corrosive or flammable gases
    - Strong vibrations or shocks
    - Direct exposure to wind and rain (outdoor sites)
    - Strong ultra-violet irradiation
  2. Take adequate measures to ensure shielding if the NT21 is used at a location subject to any of the following conditions. Otherwise the product may malfunction.
    - Static electricity, or noise from other equipment
    - Strong electromagnetic fields
    - Nearby power cables
    - Potential exposure to radioactivity

### 3-1-2 Installation in the Operation Panel

The NT21 is mounted in an operation panel by embedding it in the panel.

Use the panel fittings and tool (Philips screwdriver) included in the product package and follow the procedure below.

- 1, 2, 3...**
1. Open a hole of the dimensions shown below in the panel and install the NT21 from the front side of the panel.

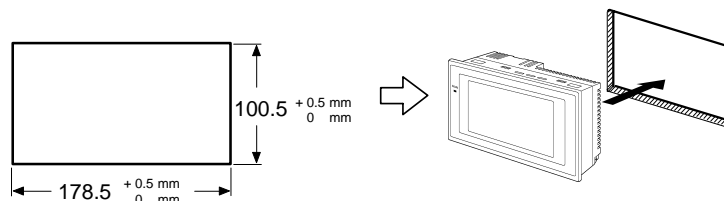

2. Attach the panel fittings at the four positions at top and bottom, shown below, from the rear of the NT21.

Fit the hook of the fitting in the square hole in the body and tighten the screw with the Philips head screwdriver while lightly pulling the fitting.

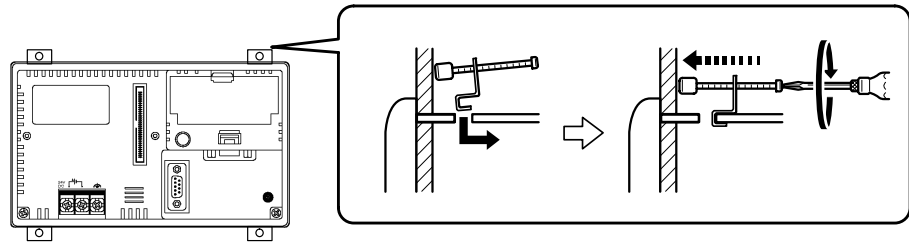

- Note**
1. During work at the panel, do not allow any metal filings or wire strands to enter the NT21. Otherwise, the product may malfunction.
  2. The thickness of applicable operation panel is 1.6 mm to 4.8 mm. All fittings must be tightened uniformly to a torque of 0.5 to 0.6 N·m in order to ensure water- and dust-resistance. Front sheet of NT21 may be warped if the tightening is too strong or not uniformity. The panel must not be soiled or warped, and must be able to support an installation that will remain secure and strong. Otherwise, the product may malfunction.

### 3-1-3 Power Supply Connection

Connect a 24 VDC power supply to the power input terminals.

**Caution** Carefully check the wiring before switching ON the power.

**Caution** Do not connect AC power to the DC terminals. Incorrect wiring may result in burning.

- Note**
1. Depending on how the power is switched ON/OFF, the entire system may stop. Follow the correct procedure when switching the power ON/OFF. Otherwise the system may operate unpredictably.
  2. Use DC power supplies with low voltage fluctuation. An incorrect power supply may result in malfunctions.
  3. Do not perform a dielectric strength test. Otherwise, the product may malfunction.
  4. If complying with EC directives (low voltage directives), use a power supply with reinforced insulation (compliance with EC directives is planned for June 1998).

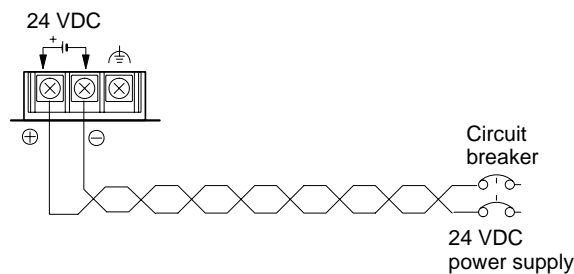

#### Power Supply

The applicable power supply specifications are as follows.

Item	Value
Power supply	24 VDC
Allowable power supply voltage fluctuation range	20.4 VDC to 27.6 VDC (24 VDC ±15%)
Power supply voltage capacity	7 W or more

**Parts Used for Connection**

**Note** For the connection to the power supply terminal block, use stranded wire of 2 mm<sup>2</sup> or greater cross sectional Area (14 AWG stranded wire) and M3.5 size crimp terminals.

Tighten the screws on the terminal block to a torque of 0.8 N·m. Otherwise the product may malfunction.

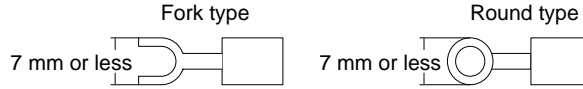

**Recommended Terminals**

Maker	Fork type	Round type	Stranded wire size
Japan Solderless Terminal MFG	2-YS3A	2-3.5	2.0 to 2.63 mm <sup>2</sup> (14 to 13 AWG)
Fuji Terminal	2-YAS3.5	V2-S3.5	
Nichifu Terminal	2Y-3.5	2-3.5	

**3-1-4 Grounding**

The NT21 has a functional ground terminal (⏏).

Carry out wiring under the following conditions.

- 1, 2, 3...
1. In cases where the distance between the NT21 is short and it is assumed that there is no potential difference between grounds, ground as shown in Fig. (a) below.
  2. In cases where there is a potential difference between the grounds of the NT21 and the host, ground as shown in Fig. (b). If there is some distance between the NT21 and host and grounding at a single point is difficult, do not connect the functional ground terminal (⏏) of the NT21.
  3. If the NT21 is installed in the same panel as equipment that generates noise, such as a motor or inverter, do not ground the functional ground terminal (⏏) of the NT21.

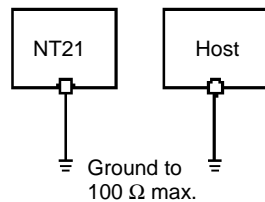

Fig. (a)

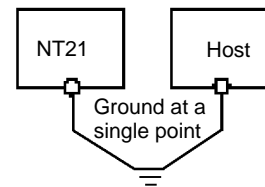

Fig. (b)

**Note** Carry out grounding correctly in order to prevent operating errors due to noise.

**3-2 Connecting Link Adapters**

This section describes the installation of the NT-AL001 and NS-AL002 Link Adapters, including the external dimensions, procedure for mounting and removal, and specifications. Refer to this information when designing the control panel. For further details, refer to the *Instruction Sheet* supplied with the NT-AL001 or NS-AL002.

**3-2-1 Connecting an NS-AL002 Link Adapter**

The NS-AL002 Link Adapter connects directly to the NT21's serial port B and converts RS-232C communications to RS-422A or RS-485. The NT21 supplies

power to the Link Adapter through pin 6 of the RS-232C connector, so an external power supply is not required.

- Note**
1. The RS-232C connector is not insulated from the RS-422A/RS-485 connector within the NS-AL002 Link Adapter.
  2. Always turn OFF the NT21's power supply before installing/removing a Link Adapter or connecting/disconnecting cables.
  3. Do not touch the surface of the printed circuit board or any electronic components with bare hands. Also, always discharge any static electricity by touching a grounded object before installing the Link adapter or connecting cables.

**Dimensions**

The following diagram shows the dimensions of the NS-AL002 Link Adapter. All dimensions are in mm.

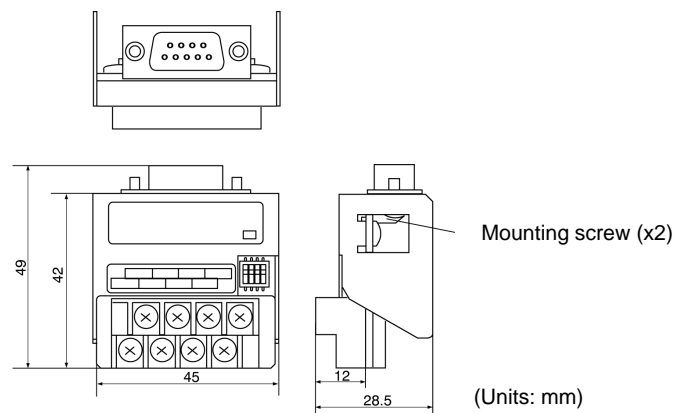

**Installation and Removal**

The NS-AL002 Link Adapter connects directly to serial port B on the NT21. After inserting the D-SUB connectors, tighten the screws on the connectors to secure them. Tighten the D-SUB connector screws to 0.3 N·m and tighten the RS-422A/RS-485 terminal screws to 0.5 N·m.

When removing the cables, loosen the screws and pull out the connectors.

**Specifications**

The following tables list the NS-AL002 Link Adapter's general and communications specifications.

**General Specifications**

Item		Specification
Dimensions		45 × 49 × 28.5 mm (W × H × D)
Weight		50 g max.
Ambient temperature	Operating	0 to 50°C
	Storage	-20 to 60°C
Operating ambient humidity		35% to 85% (with no condensation)
Rated power supply voltage		+5 V ± 10% (through pin 6 of the RS-232C connector)
Rated power supply current		150 mW max.
Operating environment		No corrosive gases
Vibration resistance		Meets the NT21's ratings.
Shock resistance		Meets the NT21's ratings.

**Communications Specifications (RS-422A/485 Interface)**

Item	Specification
Baud rate	115.2k bps max. (depends on the RS-232C baud rate)
Transmission distance	500 m max.
Terminal block configuration	8-terminal detachable terminal block, M3.0
Insulation	Non-insulated (See note.)

**Note** The RS-422A/RS-485 connector is not insulated from the RS-232C connector.

**DIP Switch Settings**

The NS-AL002 Link Adapter has a 4-pin DIP switch that sets the RS-422A/RS-485 communication conditions. Set the DIP switch before connecting the communications cable.

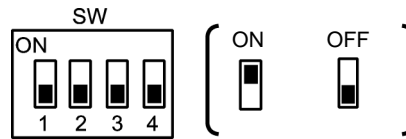

The following table shows the functions of the DIP switch pins. The factory defaults are OFF for all 4 pins.

Pin(s)	Function	ON	OFF
1	Communications mode	RS/CS control	No RS/CS control
2 and 3	Communications method	2-wire (RS-485)	4-wire (RS-232C)
4	Terminating resistance	Terminator ON	Terminator OFF

When using 1:1 NT Link communications, set the communications mode to “No RS/CS control” by turning OFF pin 1.

When using 1:N NT Link communications (standard or high-speed), set the communications mode to “RS/CS control” by turning ON pin 1.

**Pin Allocation**

The Link Adapter has an RS-232C connector and a terminal block for an RS-422A/485 interface connection. The pin arrangements for the RS-232C connector and the RS-422A/485 terminal block are as follows.

**RS-232C Connector**

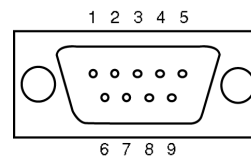

Pin	Signal name	Code	Signal direction (Link Adapter ↔ NT21)
1	Not used	---	---
2	Receive data	RD	Link Adapter ← NT21
3	Send data	SD	Link Adapter → NT21
4	Clear to send (shorted to RS internally)	CS	Link Adapter ← NT21
5	Request to send (shorted to CS internally)	RS	Link Adapter → NT21
6	+5 V (30 mA) input for Link Adapter	+5 V	Link Adapter ← NT21
7 and 8	Not used	---	Pins 7 and 8 are shorted internally



Pin	Signal name	Code	Signal direction (Link Adapter ↔ NT21)
9	Signal ground	SG	---
Connector hood	Function ground	FG	---

**RS-422A/485 Terminal Block**

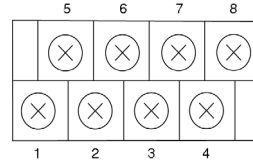

Pin	Signal name	Code	Signal direction (Link Adapter ↔ RS-422A/485 device)
1	Frame ground	FG	Connects to the Unit's functional ground terminal.
2	Receive data (+)	RDB (+)	Link Adapter ← Device
3	Send data (+)	SDB (+)	Link Adapter → Device
4	Request to send (+)	RSB (+)	Link Adapter → Device
5	No contact	NC	---
6	Receive data (-)	RDA (-)	Link Adapter ← Device
7	Send data (-)	SDA (-)	Link Adapter → Device
8	Request to send (-)	RSA (-)	Link Adapter → Device

**Compatible Crimp Terminals**

Use crimp terminals for M3 screws.

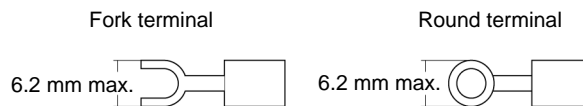

Maker	Style	Model	Compatible wire
J.S.T. Mfg Co., Ltd.	Fork	V1.25-N3A	AWG22 to AWG16 (0.25 to 1.65 mm <sup>2</sup> )
	Round	V1.25-MS3	
Molex	Fork	VSY1.25-3.5L	AWG22 to AWG16 (0.3 to 1.65 mm <sup>2</sup> )
	Round	RAV1.25-3	

**RS-422A/485 Cable Shield Connections**

When using RS-422A or RS-485 cables for long-distance communications, do not ground the shield at both ends of the communications line because large currents can flow through the shield due to the difference in potential at the two grounding points. We recommend grounding the shield at one end, as shown in the following diagram.

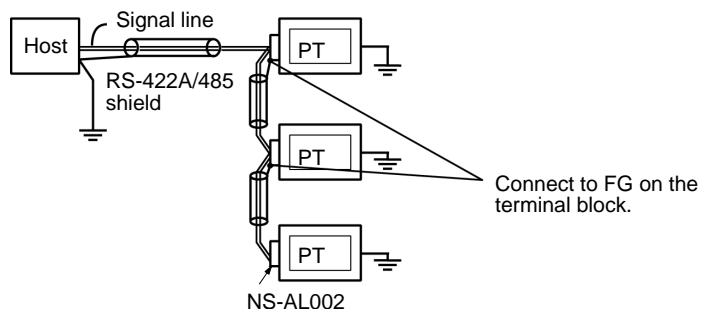

**Block Diagram**

The following diagram shows the internal block diagram of the NS-AL002-E Link Adapter. Refer to this diagram only when wiring custom cables or connecting devices with special interfaces.

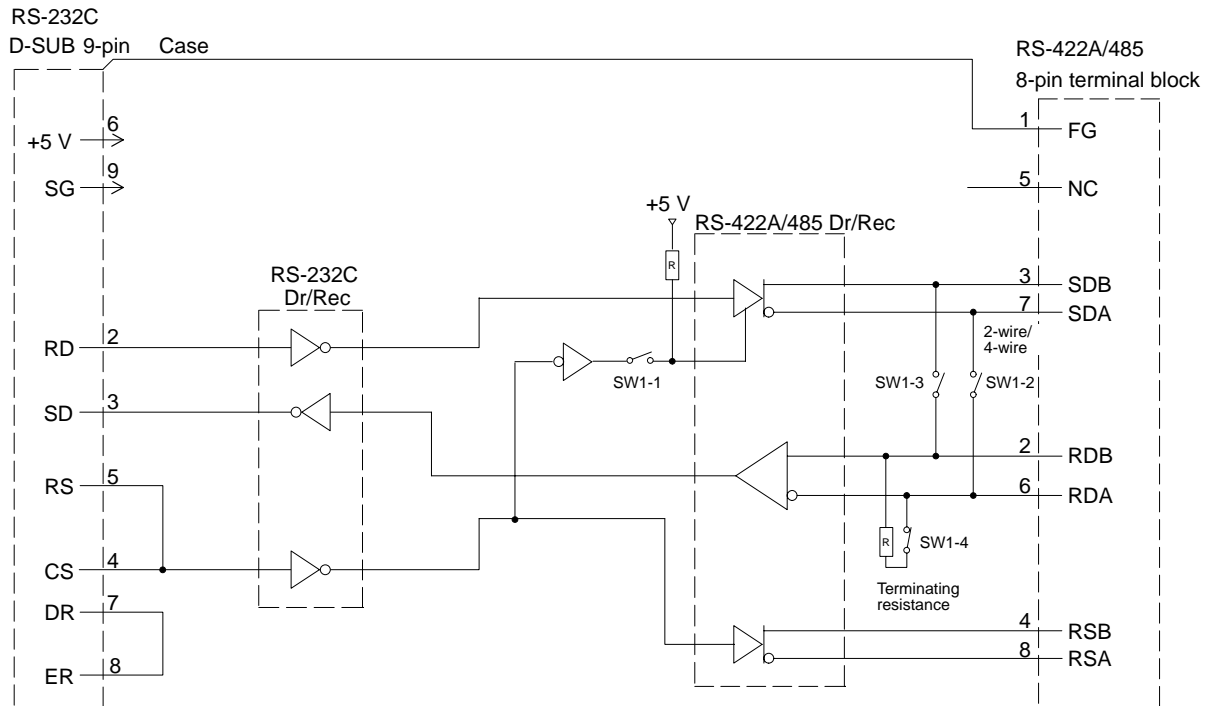

**3-2-2 Connecting an NT-AL001 Link Adapter**

The NS-AL001 Link Adapter connects to serial port A or B of the NT21 with an RS-232C cable and converts the RS-232C communications to RS-422A or RS-485. (Serial ports A and B cannot be used simultaneously.)

The NT21 supplies +5 V power (150 mA max.) to the Link Adapter through pin 6 of the RS-232C connector, so an external power supply is not required.

- Note**
1. The RS-232C connector is not insulated from the RS-422A/RS-485 connector within the NT-AL001 Link Adapter.
  2. Always turn OFF the NT21's power supply before installing/removing a Link Adapter or connecting/disconnecting cables.

**Dimensions**

The following diagram shows the dimensions of the NT-AL001 Link Adapter. All dimensions are in mm.

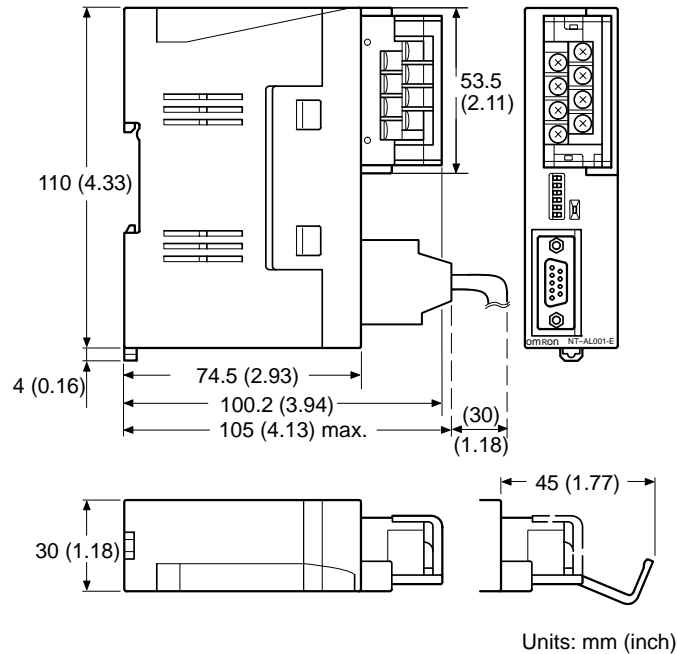

**Dimensions with RS-422A Terminal Block Cover Closed**

30 × 114 × 100.2 mm (W × H × D)

**Dimensions with RS-422A Terminal Block Cover Open**

30 × 114 × 119.5 mm (W × H × D)

**Installation and Removal**

The NT-AL001 Link Adapter can be mounted on a DIN Track or in a control panel. The Link Adapter’s RS-422A terminal block can be removed easily.

**Mounting to a DIN Track**

Latch the hook (a) on the rear of the Link Adapter onto the top edge of the DIN Track, and pivot the Link Adapter downwards (b) as shown in the diagram below.

Next, fit End Plates at the right and left of the Link Adapter to secure it so that it cannot shift laterally.

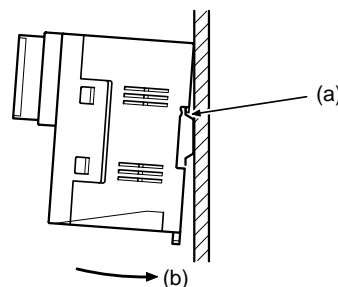

**Removal from a DIN Track**

Remove the End Plates from the right and left of the Link Adapter, insert a flat

blade screwdriver into the catch at the bottom of the Link Adapter, and pull it down to release the catch.

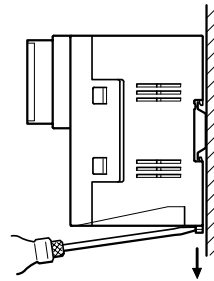

**Mounting to a Control Panel**

The control panel must be at least 2 mm (5/64 inch) thick. Drill two mounting screw holes in a control panel and secure the Link Adapter with screws.

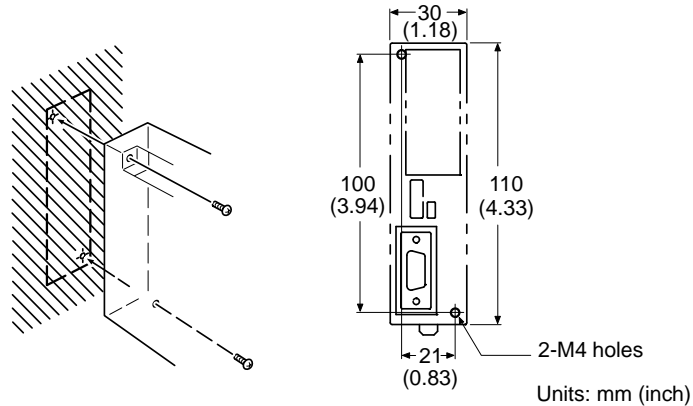

**Note** The control panel must be at least 2 mm (5/64 inch) thick for a secure and strong mount.

**Specifications**

The following tables list the NT-AL001 Link Adapter’s general and communications specifications.

**General Specifications**

Item		Specification
Dimensions		With RS-422A terminal block cover closed: 30 × 114 × 100.2 mm (W × H × D) With RS-422A terminal block cover open: 30 × 114 × 119.5 mm (W × H × D)
Weight		200 g max.
Ambient temperature	Operating	0 to 55°C
	Storage	-20 to 75°C
Operating ambient humidity		10% to 90% (with no condensation)
Rated power supply voltage		+5 V ± 10% (through pin 6 of the RS-232C connector)
Rated power supply current		150 mA max.
Inrush current		0.8 A max.
Insulation resistance		20 MΩ min., measured between the RS-422A terminal signal lines and FG terminal (with a 500 VDC megger)
Dielectric strength		1,500 VAC for 1 minute between the RS-422A terminal signal lines and the FG terminal Leakage current: 10 mA max.
Operating environment		No corrosive gases

Item	Specification
Vibration resistance	Conforms to JIS C0911, 60 minutes each in X, Y, and Z directions
Shock resistance	Conforms to JIS C0912, 147 m/s <sup>2</sup> , 3 times each in X, Y, and Z directions

**Communications Specifications (RS-422A/485 Interface)**

Item	Specification
Baud rate	115.2k bps max.
Transmission distance	2 m max.
Connector	9-pin D-SUB connector (female)

**Communications Specifications (RS-422A/485 Interface)**

Item	Specification
Baud rate	115.2k bps max. (depends on the RS-232C baud rate)
Transmission distance	500 m max.
Terminal block configuration	8-terminal detachable terminal block, M3.0

**DIP Switch Settings**

The NT-AL001 Link Adapter has a 6-pin DIP switch that sets the RS-422A/RS-485 communication conditions. Set the DIP switch before connecting the communications cable.

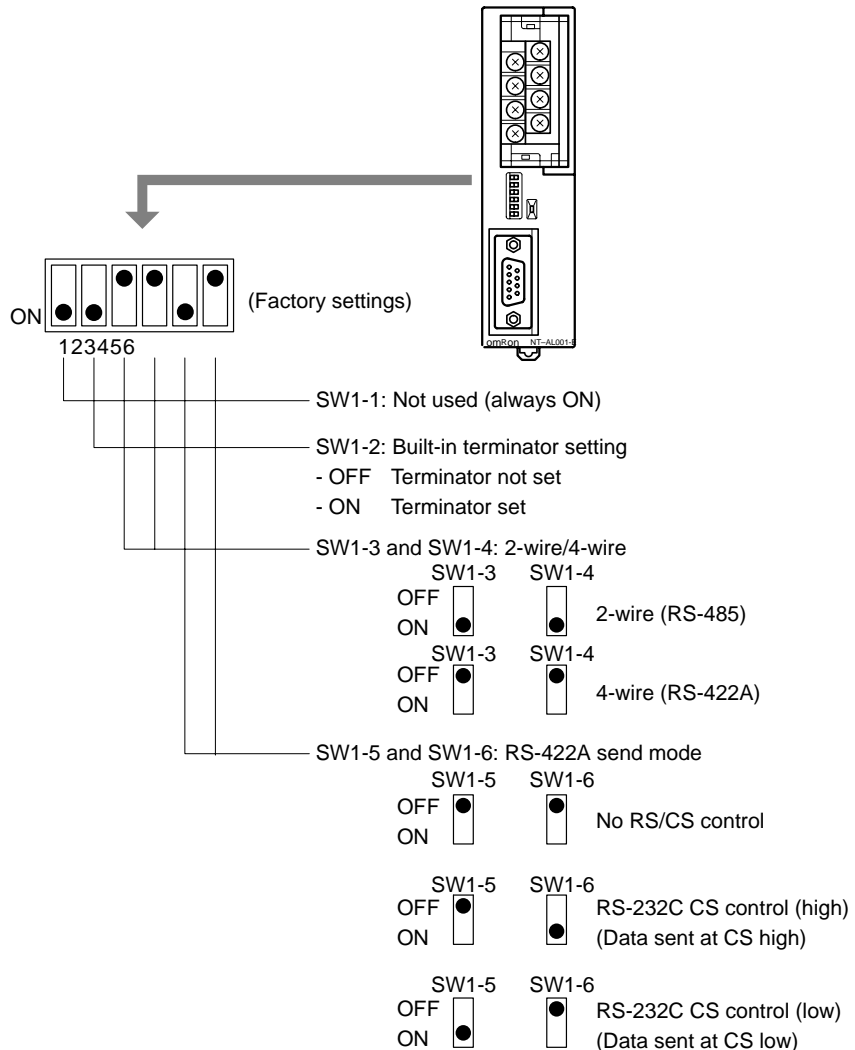

When using Host Link or 1:1 NT Link communications, set the RS-422A send mode to “no RS/CS control” by turn OFF both SW1-5 and SW1-6.

When using 1:N NT Link communications (standard or high-speed), set the communications mode to “RS/CS control” by turning ON either pin SW1-5 or SW1-6.

- Note**
1. Do not turn ON both SW1-5 and SW1-6 at the same time. This may damage internal circuits.
  2. The power supply to the device supplying +5 V must be turned OFF before starting wiring work.
  3. Before connecting the RS-232C cable and turning ON the power to an RS-232C device such as a PT (i.e., turning ON the power to the Link Adapter), check that the cable is wired correctly and that the DIP switch settings are correct. If the power is turned ON and there is a wiring fault, the internal circuits of the Link Adapter or the RS-232C device may be damaged.
  4. When the Link Adapter is connected to a C200HX/HG/HE (-ZE), CQM1H, CS1G/H, CS1G/H-H, or CJ1G model of OMRON PC as an RS-422A device, set pins SW1-5 and SW1-6 as indicated below.

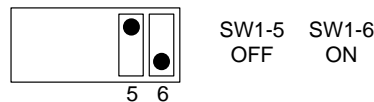

**Terminal Pin Allocation**

The NT-AL001-E Link Adapter has a terminal block for an RS-422A/485 interface connection and a connector for an RS-232C interface connection.

The pin allocations for the RS-422A/485 terminal block and the RS-232C connector are as follows.

**RS-422A/485 Terminal Block**

The CSB and CSA signals are for specialized applications.

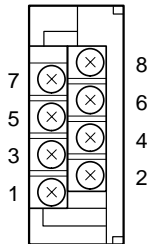

Pin	Signal name	Code	Signal direction (Link Adapter ↔ Device)
8	Request to send (-)	CSA	Link Adapter → RS-422A/485 Device
7	Request to send (+)	CSB	Link Adapter → RS-422A/485 Device
6	Receive data (-)	RDA	Link Adapter ← RS-422A/485 Device
5	Receive data (+)	RDB	Link Adapter ← RS-422A/485 Device
4	Send data (-)	SDA	Link Adapter → RS-422A/485 Device
3	Send data (+)	SDB	Link Adapter → RS-422A/485 Device
2	Signal ground	SG (GND)	---
1	Functional ground		---

**Compatible Crimp Terminals**

Use crimp terminals for M3 screws.

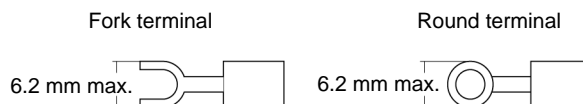

Manufacturer	Style	Model	Compatible wire
J.S.T. Mfg Co., Ltd.	Fork	V1.25-N3A	AWG22 to AWG16 (0.25 to 1.65 mm <sup>2</sup> )
	Round	V1.25-MS3	
Molex	Fork	VSY1.25-3.5L	AWG22 to AWG16 (0.3 to 1.65 mm <sup>2</sup> )
	Round	RAV1.25-3	

**RS-232C Connector**

The connector hood is connected to the RS-422A terminal block's frame ground terminal.

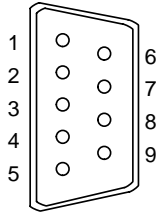

Pin	Signal name	Code	Signal direction (RS-232C Device ↔ Link Adapter)
1	Not used	---	---
2	Send data	SD	RS-232C Device ← Link Adapter
3	Receive data	RD	RS-232C Device → Link Adapter
4	Request to send (shorted to CS internally)	RS	RS-232C Device ← Link Adapter
5	Clear to send (shorted to RS internally)	CS	RS-232C Device → Link Adapter
6	+5 V (150 mA) input for Link Adapter	+5 V	RS-232C Device → Link Adapter
7	Data set ready (shorted to ER internally)	DR	RS-232C Device → Link Adapter
8	Data terminal ready (shorted to DR internally)	ER	RS-232C Device ← Link Adapter
9	Signal ground	SG	---

**Block Diagram**

The following diagram shows the internal block diagram of the NT-AL001-E Link Adapter. Refer to this diagram only when wiring custom cables or connecting devices with special interfaces.

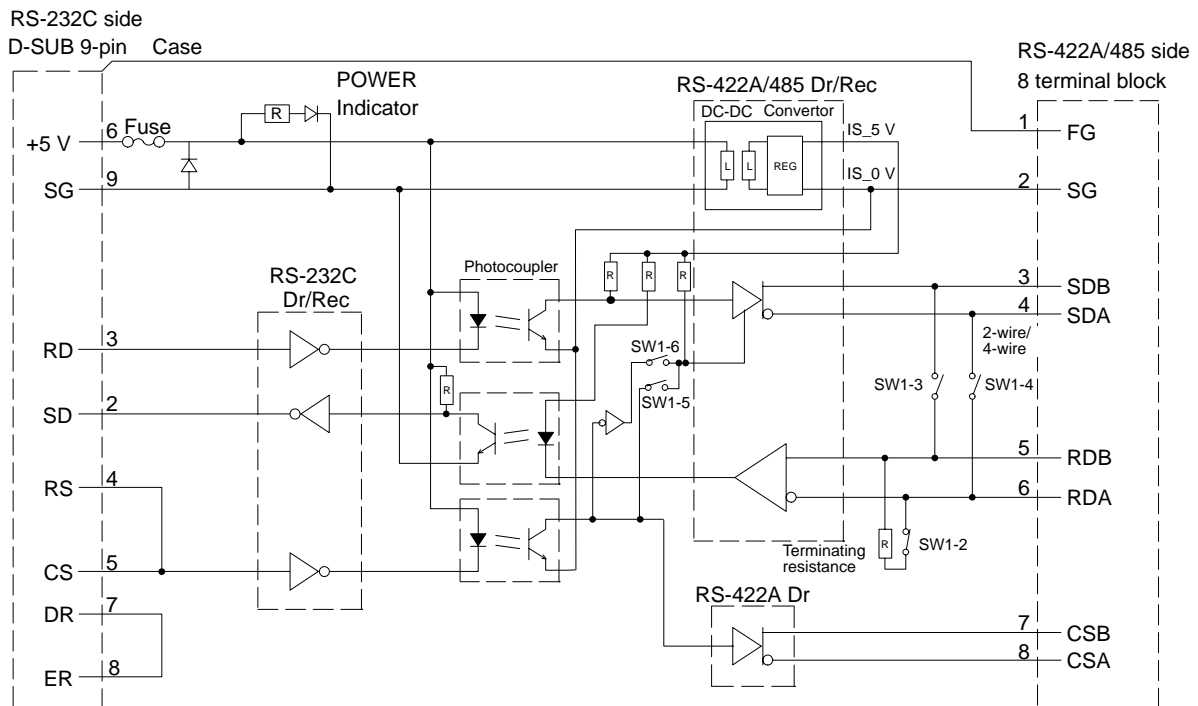

**RS-422A/485 Cable Shield Connections**

When using RS-422A or RS-485 cables for long-distance communications, do not ground the shield at both ends of the communications line because large currents can flow through the shield due to the difference in potential at the two

grounding points. We recommend grounding the shield at one end, as shown in the following diagram.

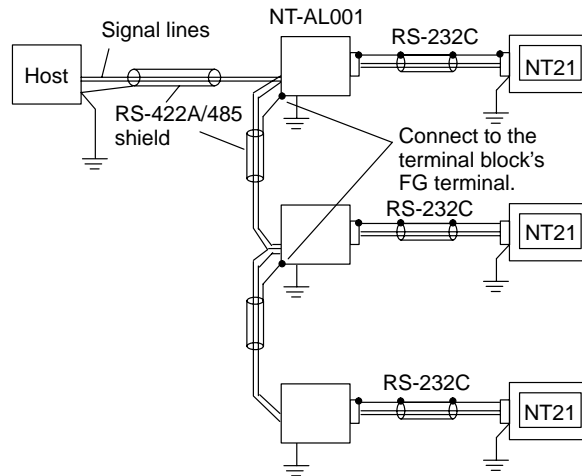

### 3-3 Connecting the NT Support Tool

In order to install the system program in the NT21, or to transmit screen data created with the NT Support Tool to the NT21, the NT21 must be connected to a personal computer with an RS-232C cable.

The NT21 connects with the RS-232C cable from a personal computer at serial port A. When the host is connected at serial port B, the connection with the host can be maintained as it is while the NT21 is connected to the RS-232C cable from a personal computer.

However, when a bar code reader is being used, it must be disconnected, so that the RS-232C cable can be connected, since they both use serial port A.

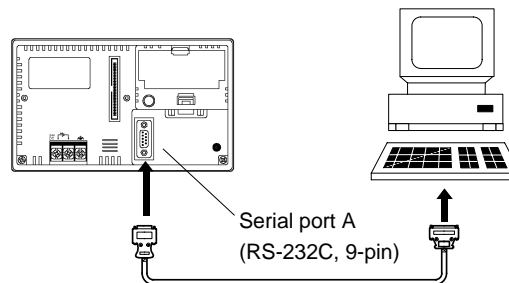

#### **Communication Conditions**

The communication conditions are automatically set when the system installer and NT Support Tool are started.

#### **Recommended Connector Cable**

Use the cable indicated below.

- CV500-CN228 (length: 2 m), made by OMRON (D-SUB 9-pin, male ↔ D-SUB 25-pin, male)
- XW2Z-S001 (conversion cable), made by OMRON (D-SUB 25-pin, female ↔ half pitch 14-pin, male)
- XW2Z-S002 (length: 2 m), made by OMRON (D-SUB 9-pin, male ↔ D-SUB 9-pin, female)

For details on making a connector cable, refer to *Appendix E Making the Cable for Connecting a PC* (page 199).



### 3-4 Connecting a Bar Code Reader

Connecting a bar code reader to the NT21 enables bar code data to be read as character strings into character string input fields, and set in the character string memory table.

In order to use a bar code reader, the Comm. A Method memory switch must be set to Bar-Code Reader.

For details on the method for inputting character strings with a bar code reader, refer to 3-7 *Input of Numeric Values and Character Strings* in the *NT31/NT31C/NT631/NT631C/NT21 Programmable Terminal Reference Manual*.

**Note** Make sure that the power supply to the bar code reader and the power supply to the PT are both OFF before connecting or disconnecting the cable.

#### 3-4-1 Connection Method

Connect the bar code reader to serial port A of the NT21, as shown in the figure below.

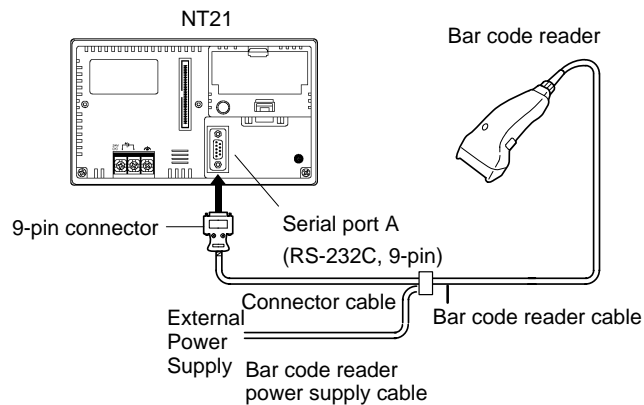

Bar code reader must match the communication setting (3-4-2 *Setting a Bar Code Reader*, page 29) and data format (3-4-3 *Data Format*, page 30) in order to connect to the NT21. Please confirm the specification of the bar code reader before using.

- Reference:**
- The bar code reader must be connected to serial port A. This means that it cannot be connected at the same time as the NT Support Tool. Note also that when a bar code reader is used, the host must be connected at serial port B.
  - Do not use serial port A's +5-V power supply as the bar code reader's power supply. Always supply power from an external power supply.

#### 3-4-2 Setting a Bar Code Reader

After connecting a bar code reader, set the communication conditions and other settings for it by selecting from the system menu.

##### Settings at the NT21

At the NT21, set the communication conditions for communication with the bar code reader by using the memory switches, selecting from the options indicated in the table below. Select from them according to communication conditions that can be set at the bar code reader or other circumstances.

For more detailed information on the actual system menu operations, refer to 6-10 *Setting the Bar Code Reader Input Function* (page 144).

Item	Possible Settings	Default Setting
Data bits	7 or 8 bits	7 bits
Stop bits	1 or 2 bits	2 bits
Parity	None, odd, even	Even

Item	Possible Settings	Default Setting
Baud rate	4800, 9600, 19200 bps	9600 bps
Input Method	Manual, Auto	Manual

**Settings at the Bar Code Reader**

Make the settings shown in the table below at the bar code reader. Make sure that the baud rate, parity, stop bit, and data bit settings match the communication settings made at the NT21. For details on the setting method, refer to the operation manual for the bar code reader used.

Item	Possible Settings
Baud rate	4800, 9600, 19200 bps
Parity	EVEN, ODD, NONE
Stop bits	1 or 2 bits
Data bits	7 or 8 bits
Preamble	STX
Postamble	ETX
RS/CS control	Available
Communication protocol	No-protocol mode
Transmission of number of bar code label digits	Transmission prohibited
Transmission of ID characters	Transmission prohibited
Bar code types	Multi-reading (all types can be read)
Trigger switch setting	Automatic reading mode

**About RS/CS Control**

During bar code reading, the NT21 performs RS/CS control. When the Input Method setting of the NT21 is set to Auto, the RS signal is turned OFF, prohibiting the next input, until the read data is notified to the host.

Because of this, when the Auto setting is made, the next input is not possible until the data is notified to the host.

However, when the setting is Auto and the RS/CS signals of the cable are shorted, RS/CS control is ineffective. Consequently, data input from the bar code reader to the NT21 is updated regardless of whether or not the data is notified to the host.

For details, refer to the operation manual for the bar code reader used.

**3-4-3 Data Format**

The data format for communication when using the bar code input function of the NT21 is shown below.

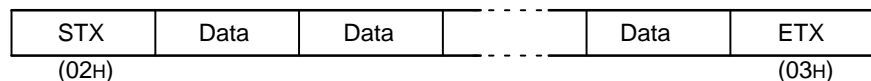

The characters that are effective as data are hexadecimal codes from 20 to 7FH, and the maximum data length is 40 bytes.

Data that does not follow the data format described above is invalidated and discarded.

## 3-5 Using a Memory Unit

This explains how to use a Memory Unit with the NT21. By installing a Memory Unit (NT-MF261) on the NT21, the system program or the screen data in the NT21 can be recorded (backed up) in the Memory Unit.

In addition, the system program or the screen data in the Memory Unit can be automatically read into the NT21 when it starts up. This means that system program and screen data can be changed easily at the operation site without connecting to the NT Support Tool.

The data in the Memory Unit is retained without backup by a battery or other means.

In systems where there are frequent setup changes, by preparing a number of Memory Units in advance and recording screen data in them in accordance with the control performed in each case, the NT21 screen data can be changed simply by installing the Memory Unit, without connecting to the NT Support Tool.

Even if NT21 is replaced, the previous status can be maintained simply by installing the Memory Unit that retains the system program and screen data of the previous NT21.

By using the following combinations, data can be stored (backed up) to a Memory Unit.

- Screen data for two PTs.
- System program for two PTs.
- System program and screen data for one PT.

One Memory Unit can store the screen data for two PTs.

- Note**
1. Make sure that the power supply to the PT is OFF before connecting or disconnecting a Memory Unit. After mounting a Memory Unit, be sure to tighten its two screws. Otherwise the product may malfunction.
  2. During data transmission, do not turn OFF the power supply to the NT21.
  3. Do not touch the PCB (printed circuit board) with bare hands.  
Also, discharge any static electricity by touching a grounded object before connecting or disconnecting a Memory Unit. Static electricity may cause the components to malfunction.

- Reference:**
- When a Memory Unit is mounted, the NT21 cannot be set to the operating status. On completion of data transmission with a Memory Unit, always disconnect the Memory Unit from the NT21 before starting NT21 operation.
  - Memory Units (NT-MF261) can be used in common for the following PT models: NT21 and NT31. One Memory Unit can store screen data for up to two PTs of different models. However, since the data compatibility is not completed among NT21 and NT31 models, an error may occur if an attempt is made to read other PT model's data with an NT21. (The data must be converted using the NT Support Tool.)
  - One Memory Unit can store a system program for up to two PTs of different models. In order to transmit a system program from the Memory Unit to the NT21, the system program must be compatible to the target PT model.
  - The status of memory switch settings and system settings can be recorded to the Memory Unit besides screen data. When the data in the Memory Unit is written into the NT21, make sure that these settings can be adapted to the NT21 used before transmission.

### 3-5-1 Installation Method

Install the Memory Unit (NT-MF261) at the expansion interface connector at the rear of the NT21 as shown in the figure below.

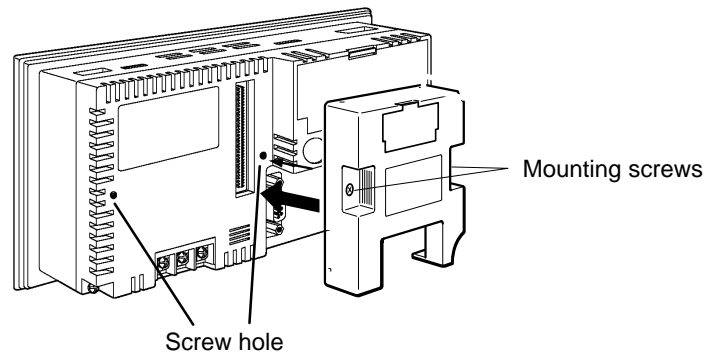

### 3-5-2 Method of Use

As shown in the figure below, a Memory Unit has 2 four-pin DIP switches, and the operation is determined by the DIP switch settings at startup.

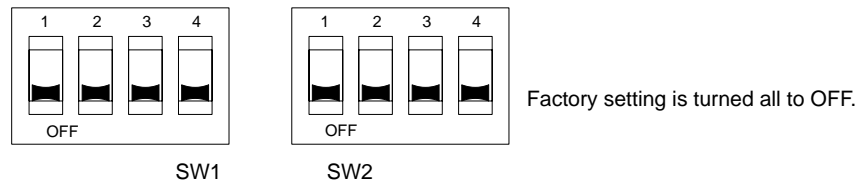

**Note** Always confirm that the power to the NT21 is OFF before setting the DIP switches.

#### DIP Switch Functions

The functions of the DIP switches on the Memory Unit are indicated in the table below.

• SW1

Pin	Function	
SW1-1	Automatic transmission (writing from the Memory Unit to the PT)	OFF: Not executed ON : Executed
SW1-2	Automatic transmission (writing from the PT to the Memory Unit)	OFF: Not executed ON : Executed
SW1-3	Manual transmission (Direction of transmission and bank used selected at the PT touch panel)	OFF: Not executed ON : Executed
SW1-4	Data type to transfer	OFF: Screen data ON : System program

• SW2

Pin	Function	
SW2-1	Disable/enable writing to PT	OFF: Disable ON : Enable
SW2-2	Disable/enable writing to the Memory Unit	OFF: Disable ON : Enable
SW2-3	Area (bank) selection of automatic transmission. *	OFF: Bank 0 ON : Bank 1

Pin	Function	
SW2-4	System/Screen simultaneous transmission	OFF: Disable
		ON : Enable

\* The Memory Unit stores system program or screen data for one PT in each of Areas (bank 0, bank 1). (The total data storage is for two PTs.) SW2-3 sets which of these two banks is used for automatic transmission.

- Reference:**
- In the following cases, a mode setting error occurs.
    - More than one of the SW1-1 to SW1-3 switches are set to ON.
    - None of the SW1-1 to SW1-3 switches are set to ON.
  - In the following case, a protect setting error occurs.  
Transmitting to the write destination has been disabled by the setting for SW2-1 or SW2-2.
  - In the following cases, a data transmission error occurs.
    - An attempt is made to transmit data other than the system program to PT System Program Area.
    - An attempt is made to transmit the system program to PT Screen Data Area.
  - For details on mode setting errors and protect setting errors, refer to *Errors When Using a Memory Unit* (page 36).

**Writing Screen Data to a Memory Unit Using Automatic Transmission (PT to Memory Unit)**

In this mode, system program or the screen data in the NT21 is forcibly written to the Memory Unit irrespective of the setting status of the NT21.

This mode is convenient if the touch panel is broken and touch switch operation is not possible, or if someone unfamiliar with touch switch operation at the operation site is using the system.

- Reference:** When screen data is written to the Memory Unit, the data that has been stored in the specified Area up until that point is lost (if the data is written into only one Bank, the other Bank will not be affected).

**Method of Execution**

Use the following procedure to write the system program or screen data in the NT21 to the Memory Unit by automatic transmission.

- 1, 2, 3...** 1. Check that the power supply to the NT21 is OFF, then set the DIP switches of the Memory Unit as follows after installing Memory Unit to NT21.

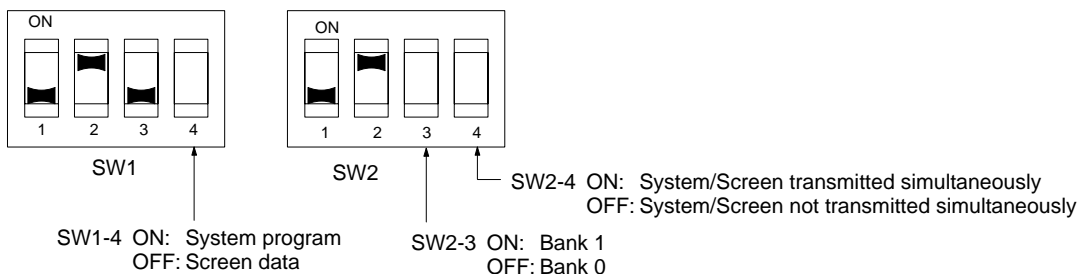

It is not strictly necessary to set SW2-1 to OFF (to disable writing to the PT), but it is recommended to do so to avoid loss of data in the event of operating errors.

- Reference:**
- Setting SW2-4 to ON (System/Screen transmitted simultaneously) disables the setting of SW1-4.
  - Setting SW2-4 to ON (System/Screen transmitted simultaneously) disables the setting of SW2-3, writes the system program into bank 0, and the screen data into bank 1 at all times.

## 2. Switch the NT21 power ON.

The screen data is automatically written into the Memory Unit. The screen data in the NT21 is preserved.

The messages Preparing, Transmitting, Verifying, and Finished are displayed on the screen in accordance with the progress of data writing.

At the same time, the progress of the data writing status is displayed by the means of the number of bytes and blocks (1 bank = 16 block = 1024k byte).

RUN Indicator operates as follows according to the processing status.

Preparing : flashes at intervals of 1 second  
 Transmitting : flashes at intervals of 0.5 second  
 Verifying : flashes at intervals of 0.5 second  
 Finished : lights up

## 3. Switch the NT21 power OFF, remove the Memory Unit.

To operate NT21 continuously, switch the NT21 power back ON.

### Writing Screen Data to the PT Using Automatic Transmission (Memory Unit to PT)

In this mode, the system program or screen data in the Memory Unit is forcibly written to NT21 irrespective of the setting status of the NT21.

Since data transmission by this method is faster than when the NT Support Tool or system installer is used, it can save a lot of time. When transmitting the same system program or screen data to multiple NT21, this mode becomes convenient.

**Reference:** When data is written to the NT21, the data that has been stored up until that point is lost. When the system program is changed, the operation of NT21 also changes.

#### Method of Execution

Use the following procedure to write the screen data in the Memory Unit to the NT21 by automatic transmission.

- 1, 2, 3...** 1. Check that the NT21 power is OFF, then set the DIP switches on the Memory Unit as follows after installing Memory Unit to NT21.

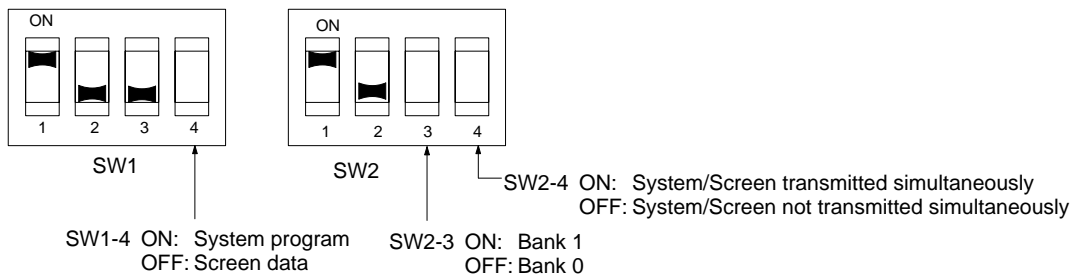

It is not strictly necessary to set SW2-2 to OFF (to disable writing to the Memory Unit), but it is recommended to do so to avoid loss of data in the event of operating errors.

- Reference:**
- Setting SW2-4 to ON (System/Screen transmitted simultaneously) disables the setting of SW1-4.
  - Setting SW2-4 to ON (System/Screen transmitted simultaneously) disables the setting of SW2-3. In this case, the data transmission becomes possible only if the data inside Memory Unit is in either of following combinations.
    - Bank 0: system program, Bank 1: other than system program
    - Bank 0: other than system program, Bank 1: system program
 If the combination is not as listed above, a data transmitting error occurs.
  - When writing the system program into the NT21, the type of system program inside Memory Unit and the PT model must correspond.

2. Switch the NT21 power ON.

The screen data is automatically written into the PT.

The messages Preparing, Transmitting, Verifying and Finished are displayed on the screen in accordance with the progress of data writing.

At the same time, the progress of data writing status is displayed by the means of the number of bytes and blocks (1 bank = 16 block = 1024k byte).

The RUN Indicator operates as follows according to the processing status.

- Preparing : flashes at intervals of 1 second
- Transmitting : flashes at intervals of 0.5 second
- Verifying : flashes at intervals of 0.5 second
- Finished : lights up

3. Switch the NT21 power OFF, remove the Memory Unit.

To operate NT21 continuously, switch the NT21 power back ON.

**Reading and Writing Data by Manual Transmission**

In this method, the direction of transmission and Area of the Memory Unit used are set by touch switch operations at the NT21. Transmission can be executed while checking the settings.

**Reference:** When data is written to the NT21 or Memory Unit, the data that has been stored up until that point is lost.

**Method of Execution**

Use the following procedure to write screen data using manual transmission.

- 1, 2, 3... 1. Check that the NT21 power is OFF, then set the DIP switches on the Memory Unit as follows.

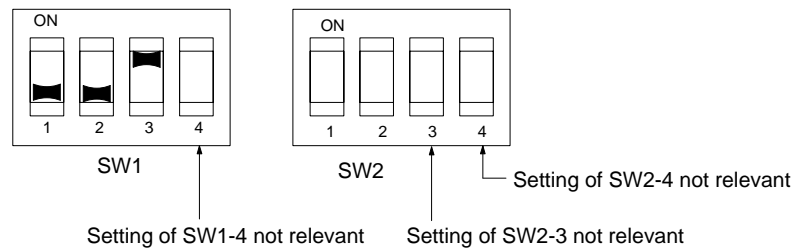

In order to avoid loss of data in the event of operating errors, it is advisable to set SW2-1 and SW2-2 so as to disable writing to the Unit from which the data is to be read.

2. Switch the NT21 power ON.  
Display language select screen appears.
3. Press the Japanese or English touch switches to select the display language.  
The screen shown below is displayed.

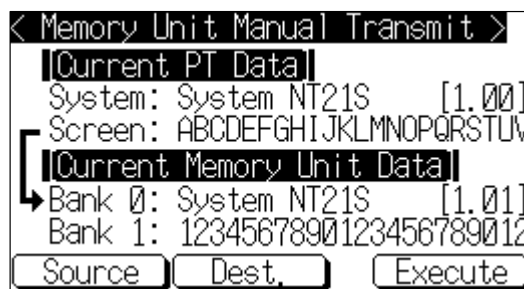

Current PT Screen Data, System

The first line: Compatible PT model for the system program inside PT.

The second line: System program name and Version for the system program inside PT.

(The second line may not be displayed in the kind of system program.)

Current PT Screen Data, Screen

The comment for the screen data in the NT21 is displayed here.

Current Memory Unit Screen Data

- In the case of system program:

The first line: Compatible PT model for the system program inside the Memory Unit.

The second line: System program name and Version for the system program inside the Memory Unit.

(The second line may not be displayed in the system program for some models.)

- In the case of screen data:

The comment for the screen data in the NT21 is displayed here.

The available transmitting destinations are altered depending on the settings of the source of transmitting as described in the table below.

Source	Destination
[PT]screen	→[Memory Unit] Bank 0 → [Memory Unit] Bank 1
[PT]system	
[PT]system/screen	[Memory Unit] Bank 0/1 (fixed)
[Memory Unit] Bank 0	• If system program is selected [PT]system (fixed)
[Memory Unit] Bank 1	• If screen data is selected [PT]screen (fixed)
[Memory Unit] Bank 0/1	[PT]system/screen (fixed)

**Reference:**

- When transmitting the system program and screen data simultaneously from the PT to the Memory Unit, the setting of banks is Bank 0: system program, Bank 1: screen data, and when transmitting them from the Memory Unit to the PT, either of the following combinations must be used.
  - Bank 0: system program, Bank 1: other than system program
  - Bank 0: other than system program, Bank 1: system program
- When writing the system program into the NT21, the type of system program inside Memory Unit and the PT model must correspond.

4. Press Execute.

The data is transmitted.

The messages Preparing, Transmitting, Verifying, and Finished are displayed in accordance with the progress of data transmission. At the same time, the progress of data transmitting status is displayed by the means of the number of bytes and blocks (1 bank = 16 block = 1024k byte).

When the data transmission is operated manually, RUN Indicator remains OFF.

5. Switch the NT21 power OFF, remove the Memory Unit, then switch the NT21 power back ON.

If an error occurs when using the Memory Unit, the NT21 operates as follows.

- The details of the error and remedial action are displayed on the screen.

Each screen has touch switches to change the display language from one to the other. When the manual data transmission is operating, the content of

**Errors When Using a Memory Unit**



error and remedial action are shown with selected language. When the automatic transmission is operating, it is displayed in Japanese.

- The continuous buzzer sounds.
- The RUN Indicator flashes.

If a protect setting error occurs when executing manual transmission, it is possible to return to the Memory Unit manual transmission screen by pressing the OK touch switch, but in the case of other errors, the status described above remains in effect until the NT21 power is turned OFF or reset.

When an error occurs, take remedial action by referring to the table below.

Error	Probable Cause	Remedial Action
Mode setting error	DIP Switch pins SW1-1 to SW1-3 are all OFF, or more than one is ON.	Turn the NT21 power OFF, set the Memory Unit DIP switches correctly, then turn the NT21 power back ON.
Protect setting error (automatic transmission)	Writing to the data write destination has been prohibited by the setting of SW2-1 or SW2-2.	Turn the NT21 power OFF, set the Memory Unit DIP switches correctly, then turn the NT21 power back ON.
Protect setting error (manual transmission)	Writing to the data write destination has been prohibited by the setting of SW2-1 or SW2-2.	Perform either of the following procedures. <ul style="list-style-type: none"> <li>• Press the OK touch switch to return to the Memory Unit manual transmission screen, make the correct settings, then try again.</li> <li>• Turn the NT21 power OFF, correct the DIP switches settings of the Memory Unit, then turn the power back ON.</li> </ul>
Flash memory error	An error occurred during initialization of the NT21 or Memory Unit flash memory, or during write processing.	Turn the NT21 power OFF, then back ON. If the error recurs, the flash memory at the write destination may be faulty. In this case, replace the Unit.
Verify error	An error occurred during verification processing at the flash memory of the NT21 or the Memory Unit.	Turn the NT21 power OFF, then back ON. If the error recurs, the flash memory at the write destination may be faulty. In this case, replace the Unit.
Transmitting data error (The automatic transmission only)	An attempt is made to transmit data other than a system program or the system program of a different PT model into the NT21 as the system program. An attempt is made to write a system program into the NT21 as screen data.	Perform either of the following procedures. <ul style="list-style-type: none"> <li>• Turn the NT21 power OFF, correct the DIP switch settings of the Memory Unit, and then turn the power back ON.</li> <li>• Turn the NT21 power OFF, set the DIP switch settings to the manual transmission, and then check the data inside the Memory Unit.</li> </ul>

# SECTION 4

## Connecting to the Host from the RS-232C Port

This section describes how to connect the host directly to the NT21's RS-232C port.

4-1	Connecting to the RS-232C Port at the Host .....	40
4-1-1	Host Types and Settings .....	40
4-1-2	Connecting Directly between RS-232C Ports .....	63

## 4-1 Connecting to the RS-232C Port at the Host

The method for connecting directly between the RS-232C port of the PT and the RS-232C port of the host is as follows.

The following discussion is focused on the connection method to OMRON PCs (By using the memory link method, a connection can be made to any arbitrary RS-232C device.)

### **Direct Connection between RS-232C Ports with RS-232C Cable (Page 77)**

This is the easiest connection method. Depending on the host to which the connection is to be made, it may be possible to use OMRON cables with connectors.

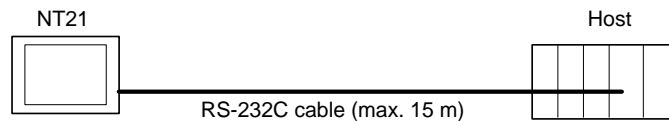

**Reference:** The CS/CJ-series CPU Unit cannot be connected with the 1:1 connection NT link method. Use the 1:N connection NT link method instead of making the 1:1 connection. For details, refer to *Using the 1:N NT Link* (page 55) or *Using the High-speed 1:N NT Link* (page 60).

### 4-1-1 Host Types and Settings

The types of host that can be connected to a PT by using the RS-232C ports of both devices, and the settings to be made at the host, are described here.

#### **Using the Host Link Method**

##### **Compatible Hosts**

Some models and series of OMRON PCs have the Host Link function built in. In the CS-series (including the CS1-H PCs), CJ-series, and CQM1H PCs, the Host Link method can be used by installing a Serial Communications Board or Unit. In addition, some C200HX/HG/HE(-Z)E have an integral CPU Unit that can be connected in the Host Link method by installing a Communication Board. Check the model and series of the PC, the type of installed Serial Communications Board, Serial Communications Unit, or Host Link Unit before making a connection.

The hosts that can be connected to the NT21 by the Host Link method using the RS-232C ports of both Units are indicated in the table below.

PC Series	Units with Built-in Host Link Function	CPU Units Connectable with Host Link Units or Expansion Communication Board	Host Link Unit/ Communication Board	Connectable to
CS Series	CS1G-CPU42/43/44/45-EV1 CS1H-CPU63/64/65/66/67-EV1 CS1G-CPU42H/43H/44H/45H CS1H-CPU63H/64H/65H/66H/67H	CS1G-CPU42/43/44/45-EV1 CS1H-CPU63/64/65/66/67-EV1 CS1G-CPU42H/43H/44H/45H CS1H-CPU63H/64H/65H/66H/67H	CS1W-SCU21 CS1W-SCB21 CS1W-SCB41	CS1G CS1H CS1G-H CS1H-H
CJ Series	CJ1G-CPU44/45	CJ1G-CPU44/45	CJ1W-SCU41	CJ1G
C Series	---	C200HS-CPU01/03/21/23/31/33-E C200HE-CPU11/32/42-E C200HE-CPU11/32/42-ZE C200HG-CPU33/43/53/63-E C200HG-CPU33/43/53/63-ZE C200HX-CPU34/44/54/64-E C200HX-CPU34/44/54/64/65/85-ZE	C200H-LK201-EV1	C200HS C200HE C200HE-Z C200HG C200HG-Z C200HX C200HX-Z
	C200HS-CPU21/23/31/33-E	---	---	C200HS
	C200HE-CPU42-E C200HE-CPU42-ZE	C200HE-CPU32/42-E C200HE-CPU32/42-ZE	C200HW-COM02/04/ 05/06-EV1	C200HE C200HE-Z
	C200HG-CPU43/63-E C200HG-CPU43/63-ZE	C200HG-CPU33/43/53/63-E C200HG-CPU33/43/53/63-ZE		C200HG C200HG-Z
	C200HX-CPU44/64-E C200HX-CPU44/64/65/85-ZE	C200HX-CPU34/44/54/64-E C200HX-CPU34/44/54/64/65/85-ZE		C200HX C200HX-Z
	CPM1-10/20/30CDR-□ +CPM1-CIF01	---	---	CPM1
	CPM1A-10/20/30/40CD□-□ +CPM1-CIF01	---	---	
	CPM2A-30/40/60CD□□-□ +CPM1-CIF01 (Peripheral port connection)	---	---	CPM2A
	CPM2C-10/20□□□□□□-□ (*1)	---	---	CPM2C
	CQM1-CPU21-E CQM1-CPU41/42/43/44-EV1	---	---	CQM1
CQM1H-CPU11/21/51/61 (*2)	CQM1H-CPU51/61	CQM1H-SCB41	CQM1H	
CVM1 Series (*3)	CVM1-CPU01-EV2 CVM1-CPU11-EV2 CVM1-CPU21-EV2	CVM1-CPU01-EV2 CVM1-CPU11-EV2 CVM1-CPU21-EV2	CV500-LK201	CVM1
Compo-Bus/S Master Unit	SRM1-C02-V1	---	---	SRM1

\*1: Use a CPM2C-CN111 or CS1W-CN114/118 Connecting Cable, CPM1-CIF01 RS-232C Adapter, or CPM1-CIF11 RS-422A Adapter to connect.

\*2: The CQM1H-CPU11 does not have a built-in RS-232C port, so connect to the PT at the peripheral port with a CS1W-CN118 Connecting Cable.

\*3: CPU Units of CVM1/CV-series PCs without the suffix -EV□ cannot be connected.

**Settings at the Host**

When using the Host Link method, the settings shown below must be made at the host (depending on the Unit, some of these settings may not be necessary, or settings not shown here may be necessary).

Item	Switch Setting
I/O port	RS-232C
Baud rate	Set the same baud rate as for the NT21. (*1)
Transfer code	ASCII, 7 data bits, 2 stop bits
Parity	Even
1-to-1/1-to-N	1-to-N(*2)

Item	Switch Setting
Command level	Level 1, 2, 3
Unit #	00

- \*1 Set the Host Link baud rate at 9,600 bps or 19,200 bps with the memory switch at the NT21. For details, refer to *Setting the Host Link Method* (page 127).
- \*2 The 1-to-N setting enables BCC (Block Check Character). It is not actually possible to connect more than one NT21 in a single Host Link.

The setting methods for each Unit are described below.

**Connecting to a C-series Host Link Unit**

**C200H/C200HS/C200HE/HG/HX (-Z)E Rack-mounted Unit:  
C200H-LK201-V1**

**Setting the Front Switches**

Set each switch with a flat blade screwdriver so that the values or symbols in the setting value window agree with the following.

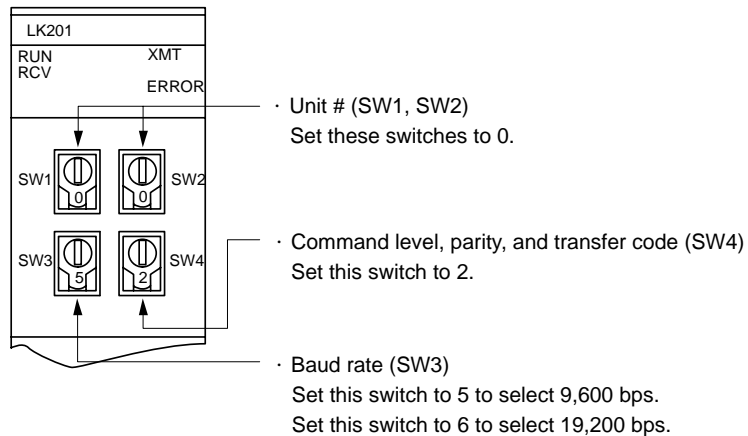

**Setting the Rear Switches**

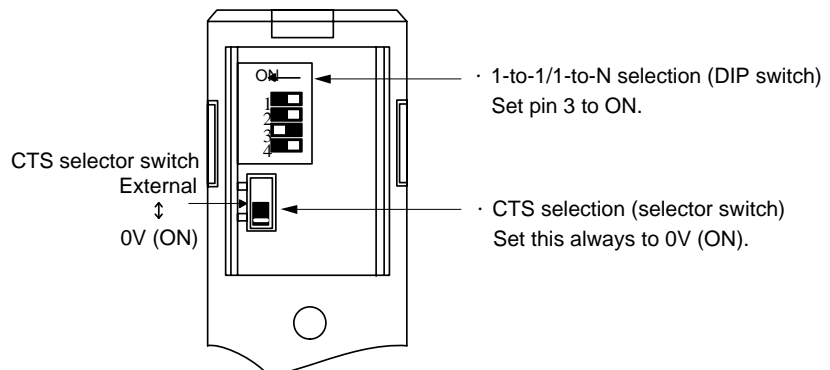

**Connecting to a CVM1/CV-series Host Link Unit**

**CVM1/CV-series Rack-mounted Unit: CV500-LK201**

A CVM1/CV-series Host Link Unit (CV500-LK201) has two connectors (communication ports 1 and 2). Either of these ports can be used for connection to an NT21 by the RS-232C method. However, since the connectors at these ports are of different types, a cable that matches the connector must be prepared.

- Communication port 1  
Communication port 1 is a 25-pin connector for RS-232C use only.
- Communication port 2  
Communication port 2 is a 9-pin connector that allows selection of the RS-232C or RS-422A method. When this port is used with the RS-232C meth-

od, the I/O port selector switch on the front of the Unit must be set to RS-232C (the upper position).

**CPU Bus Unit Settings**

When connecting to a CVM1/CV-series Host Link Unit, set the following communication conditions for the CPU Bus Unit settings.

Item	Setting at Host
Baud rate	Set the same baud rate as set at the NT21 <sup>(*1)</sup>
Transfer code	ASCII, 7 data bits, 2 stop bits
Parity	Even
1-to-1, 1-to-N	1-to-N <sup>(*2)</sup>
Command level	Level 1, 2, 3

- \*1 Set the Host Link baud rate at 9,600 bps or 19,200 bps with the memory switch at the NT21. For details, refer to *Setting the Host Link Method* (page127).
- \*2 The 1-to-N setting enables BCC (Block Check Character). It is not actually possible to connect more than one NT21 in a single Host Link.

Set the CPU Bus Unit settings directly from a Programming Device (e.g., SYSMAC Support Software).

For details on the CPU Bus Unit settings, refer to the *SYSMAC CVM1/CV-series Host Link Unit Operation Manual* (W205-E1-□).

**Setting the Front Switches**

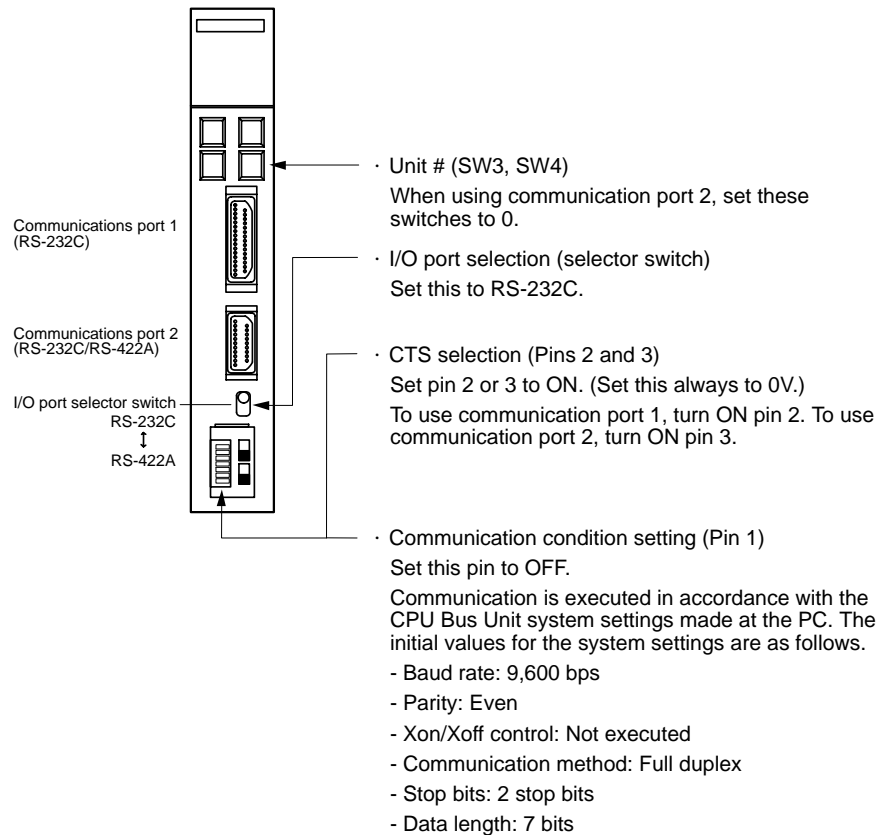

**Connecting to a CS/CJ-series Serial Communications Unit**

**CS/CJ-series Rack-mounted Unit: CS1W-SCU21**

**CJ-series: CJ1W-SCU41 (Port 2 is an RS-232C Port.)**

**Setting the Front Switches**

Set the unit number of the Serial Communications Unit by using the rotary switch

located on the front panel. Set each switch with a flat blade screwdriver so that the values or symbols in the setting value window agree with the following.

CS1W-SCU21

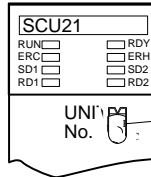

Set the unit number to 0 through F so that it will not duplicate the numbers used in other Units.

CJ1W-SCU41

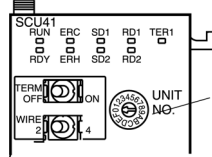

Set the unit number to 0 through F so that it will not duplicate the numbers used in other Units.

**Allocation DM Area Settings for CPU Unit**

Settings are written from the Programming Device (a Programming Console or CX-Programmer) directly into the allocated DM Area (PC Setup) of the CPU Unit. After the settings are written, they become effective by turning the power ON, restarting the Unit, restarting the communication port, or execution of the STUP instruction.

The following table shows the words allocated in the DM Area and the settings.

$$m = DM30000 + 100 \times \text{unit number}$$

Allocated DM word		Value	Settings
Port 1	Port 2		
m	m+10	8000	Host Link mode, 2 stop bits, even parity, data length 7 bits
m+1	m+11	0000	Baud rate 9,600 bps.
		0007	Baud rate 19,200 bps.
m+2	m+12	0000	Transmit delay time 0 ms.
m+3	m+13	0000	No CTS control Unit No.0 for Host Link

**Connecting to a CPU Unit**

**CV-series and CVM1/CV-series (-EV□) CPU Units**

CVM1-CPU01-EV2/CVM1-CPU11-EV2/CVM1-CPU21-EV2

**PC Setup**

When connecting to a CVM1/CV-series CPU Unit, set the following communication conditions for the PC Setup.

Item	Setting at Host
Baud rate	Set the same baud rate as set at the NT21(*1)
Stop bits	2 stop bits
Parity	Even
Data length	ASCII 7 bits
Unit #	00

\*1 Set the Host Link baud rate at 9,600 bps or 19,200 bps with the memory switch at the NT21. For details, refer to *Setting the Host Link Method* (page 127).

Either set PC Setup directly from a Programming Device (e.g., SYSMAC Support Software), or transmit the PC Setup made at a Programming Device to the CPU Unit.

For details on the PC Setup, refer to the *SYSMAC CVM1/CV500/1000/2000 Operation Manual: Ladder Diagrams (W202-E1-□)*.

Setting the Front Switches

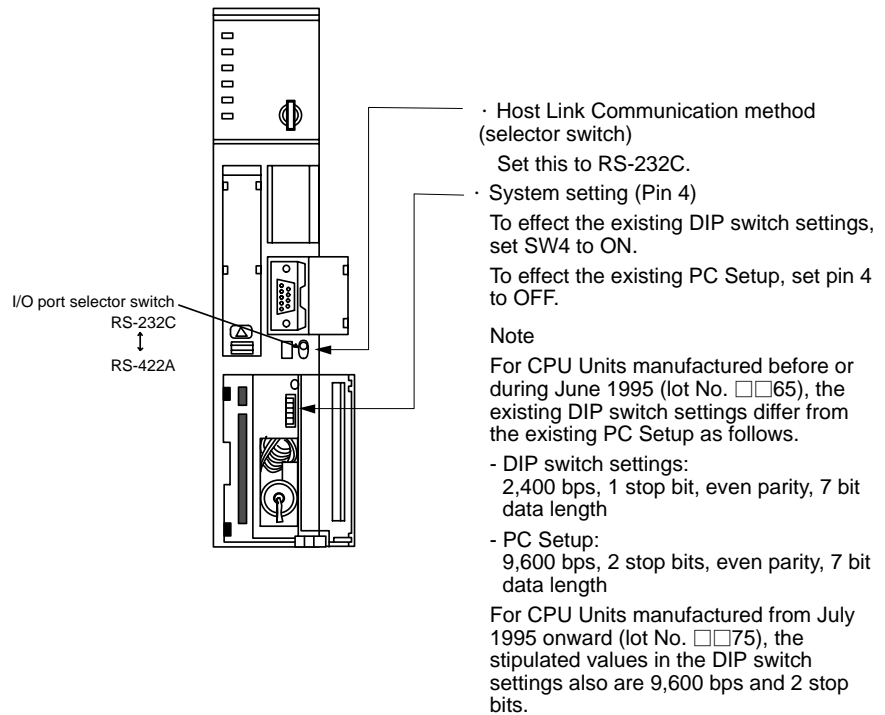

**C-series C200HS, C200HX/HG/HE(-Z)E, CPM1, CPM2A, CPM2C, CQM1, CQM1H CPU Units and SRM1**

The connection method depends upon the model of PC being used, as shown in the following table.

PC model	Connection method
C200HS, CQM1	Connect to the CPU Unit's built-in RS-232C port.
C200HX/HG/HE(-Z)E	<ul style="list-style-type: none"> <li>• Connect to the CPU Unit's built-in RS-232C port.</li> <li>• Connect to one of the RS-232C ports (port A or port B) on a Serial Communications Board.</li> </ul>
CQM1H	<ul style="list-style-type: none"> <li>• Connect to the CPU Unit's built-in RS-232C port.</li> <li>• Connect to the peripheral port through a CS1W-CN118 Connecting Cable.</li> <li>• Connect to the RS-232C port (port 1) on a Serial Communications Board.</li> </ul>
CPM1	Connect to the peripheral port through a CPM1-CIF01 RS-232C Adapter.
CPM2A, SRM1	<ul style="list-style-type: none"> <li>• Connect to the CPU Unit's built-in RS-232C port.</li> <li>• Connect to the peripheral port through a CPM1-CIF01 RS-232C Adapter.</li> </ul>
CPM2C	<p>Connect to the CPU Unit's RS-232C port or the peripheral port through a Connecting Cable (CPM2C-CN111, CS1W-CN118, or CS1W-CN114).</p> <p>(The CPM2C-CN111 splits the Unit's Communication Port into a RS-232C port and a peripheral port. A CPM1-CIF01 RS-232C Adapter is also required to connect to this peripheral port.)</p>



**PC Setup Settings**

When connecting to a C200HS, C200HX/HG/HE(-Z)E, CPM1, CPM2A, CPM2C, CQM1, or CQM1H CPU Unit, or SRM1, set the following communication conditions for the PC Setup.

Item	Setting at Host
Communication mode	Host Link mode
Baud rate	Set the same speed as set at the NT21 <sup>(*1)</sup>
Stop bits	2 stop bits
Parity	Even
Data length	ASCII 7 bits
Unit #	00

\*1 Set the Host Link baud rate at 9,600 bps or 19,200 bps with the memory switch at the NT21. For details, refer to *Settings the Host Link Method* (page127).

Set the PC Setup settings directly from a Programming Device (e.g., the CX-Programmer Support Software).

For details on operations relating to the PC Setup, refer to the manual for the PC which is used.

The PC Setup area word addresses and settings to be made depending on the Unit and port to which the connection is made are shown below.

CPM2A, CPM2C, CQM1H, or SRM1: Peripheral port connection

Word	Writing Value	Settings
DM6650	0001	Host Link mode, no CTS control Communication conditions set by the contents of DM
DM6651	0303	Data length 7 bits, 2 stop bits, even parity, baud rate: 9,600 bps
	0304	Data length 7 bits, 2 stop bits, even parity, baud rate: 19,200 bps
DM6653	0000	Unit # 00

C200HS, C200HX/HG/HE(-Z)E, CPM2A, CPM2C, CQM1, CQM1H (other than the CPU11), or SRM1: Built-in RS-232C port connection

Word	Writing Value	Settings
DM6645	0001	Host Link mode, no CTS control Communication conditions set by the contents of DM
DM6646	0303	Data length 7 bits, 2 stop bits, even parity, baud rate: 9,600 bps
	0304	Data length 7 bits, 2 stop bits, even parity, baud rate: 19,200 bps
DM6648	0000	Unit # 00

C200HX/HG/HE(-Z)E: Serial Communications Board port A

CQM1H: Serial Communications Board port 1

Word	Writing Value	Settings
DM6555	0001	Host Link mode, no CTS control Communication conditions set by the contents of DM
DM6556	0303	Data length 7 bits, 2 stop bits, even parity, baud rate: 9,600 bps
	0304	Data length 7 bits, 2 stop bits, even parity, baud rate: 19,200 bps
DM6558	0000	Unit # 00

C200HX/HG/HE(-Z)E: Serial Communications Board port B

Word	Writing Value	Settings
DM6550	0001	Host Link mode, no CTS control Communication conditions set by the contents of DM
DM6551	0303	Data length 7 bits, 2 stop bits, even parity, baud rate: 9,600 bps
	0304	Data length 7 bits, 2 stop bits, even parity, baud rate: 19,200 bps
DM6553	0000	Unit # 00

CPM1: Peripheral port connection through a CPM1-CIF01 RS-232C Adapter

Word	Writing Value	Settings
DM6650	0001	Host Link mode Communication conditions set by the contents of DM
DM6651	0303	Data length 7 bits, 2 stop bits, even parity, baud rate: 9,600 bps
	0304	Data length 7 bits, 2 stop bits, even parity, baud rate: 19,200 bps
DM6653	0000	Unit # 00

**Connecting to a CPM2C**

The CPM2C PCs do not have the same kind of port connectors found on CS1-series PCs. The CPM2C's communication port handles both RS-232C and peripheral port connections, which are divided internally. Therefore, when using the CPM2C, it is necessary to select RS-232C or peripheral port connections, according to the kind of cable and port (on the cable) used, as shown in the following table. Refer to the *CPM2C Operation Manual* for more details.

Port connecting to PT	PC Setup
RS-232C port (D-Sub 9-pin) of CPM2C-CN111	Built-in RS-232C port settings
Peripheral port of CPM2C-CN111	Peripheral port settings
RS-232C port (D-Sub 9-pin) of CS1W-CN118	Built-in RS-232C port settings
Peripheral port of CS1W-CN114	Peripheral port settings

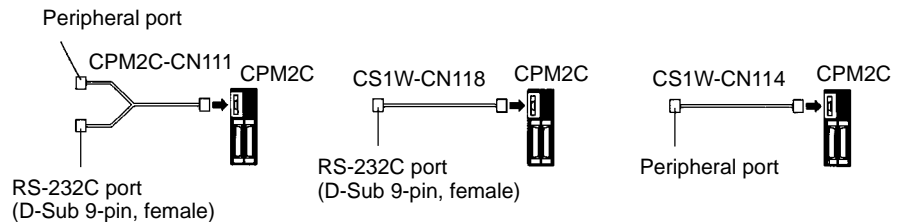

**Setting the DIP Switches of a C200HX/HG/HE(-Z)E, CQM1, or CQM1H**

When using a C200HX/HG/HE(-Z)E, CQM1, or CQM1H, the DIP switches on the front panel must be set as shown below in order to make the settings in the PC Setup (in the DM Area) effective.

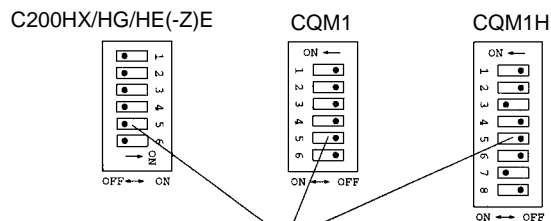

RS-232C port communication condition setting  
Set pin 5 to OFF to make the settings made in PC Setup effective.

When using the CQM1H's built-in peripheral port, turn ON SW7.

**Setting the Switches of a CPM2A**

When using a CPM2A, the switches on the front panel must be set as shown below in order to make the PC Setup settings effective.

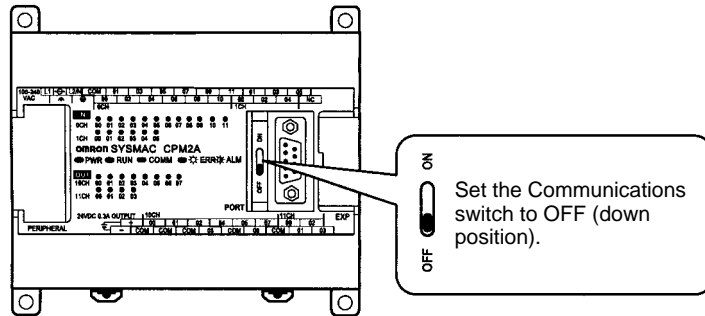

**Setting the Switches of a CPM2C**

When using a CPM2C, the switches on the front panel must be set as shown below in order to make the PC Setup settings effective.

The settings for SW1 and SW2 depend upon the usage of the peripheral port and RS-232C port.

- Connecting PT to peripheral port
- Connecting PT to built-in RS-232C port  
(A device that requires non-standard communications settings is connected to the peripheral port.)

SW1: OFF  
SW2: ON

- Connecting PT to built-in RS-232C port  
(A Programming Console is connected to the peripheral port.)

SW1: OFF  
SW2: OFF

**Setting the Switches on an RS-232C Adapter**

When using a CPM1-CIF01 RS-232C Adapter, set the mode switch as shown in the following diagram.

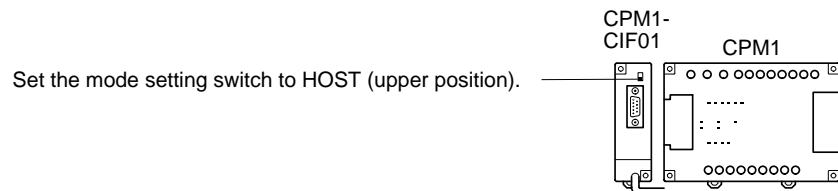

**CS/CJ-series CPU Unit model: CS1G/H-CPU□□-E (-V1)**

**CS1G/H-CPU□□H**

**CJ1G-CPU□□**

Connect to the built-in RS-232C port of the CPU Unit, or the RS-232C port of the Communication Board. Note that the connection to a peripheral port must be made via an RS-232C Adapter (CS1W-CN118) specially designed for connecting to a peripheral port.

**PC Setup**

When connecting to a CS/CJ-series CPU Unit, set the following communication conditions for the PC Setup. Since the settings shown below are the PC default settings for the CPU Unit, no change to the PC Setup is necessary as long as the baud rate is maintained at 9,600 bps.

Item	Setting at Host
Baud rate	Set the same speed as set at the NT21 <sup>(*1)</sup>
Stop bits	2 stop bits
Parity	Even
Data length	ASCII 7 bits
Unit No. for the Host Link	00

\*1 Set the Host Link baud rate at 9,600 bps or 19,200 bps with the memory switch at the NT21. For details, refer to *Settings the Host Link Method* (page 127).  
When the baud rate is set to 19,200 bps, the PC Setup of the CPU Unit need to be changed.

Either set the PC Setup directly from a Programming Device (Programming Console), or transmit the PC Setup made at a Programming Device (CX-Programmer) to the CPU Unit.

For details on PC Setup, refer to the *SYSMAC CS Series Operation Manual* (W339-E1-□) or *SYSMAC CJ Series Operation Manual* (W393-E1-□).

When using the built-in RS-232C port of a CS1G/H, CS1G/H-H, or CJ1G

Word address	Writing Value	Settings
CIO 160	8000	Host Link mode, data length 7 bits, 2 stop bits, even parity
CIO 161	0000	Baud rate: 9,600 bps.
	0007	Baud rate: 19,200 bps.
CIO 166	0000	Unit #00

When using the peripheral port of a CS1G/H, CS1G/H-H, or CJ1G

Word address	Writing Value	Settings
CIO 144	8000	Host Link mode, data length 7 bits, 2 stop bits, even parity
CIO 145	0000	Baud rate: 9,600 bps.
	0007	Baud rate: 19,200 bps.
CIO 150	0000	Unit #00

**Setting the Front Switches**

Set pins 4 and 5 of the CPU Unit DIP switch in accordance with the port that the NT21 is connected to.

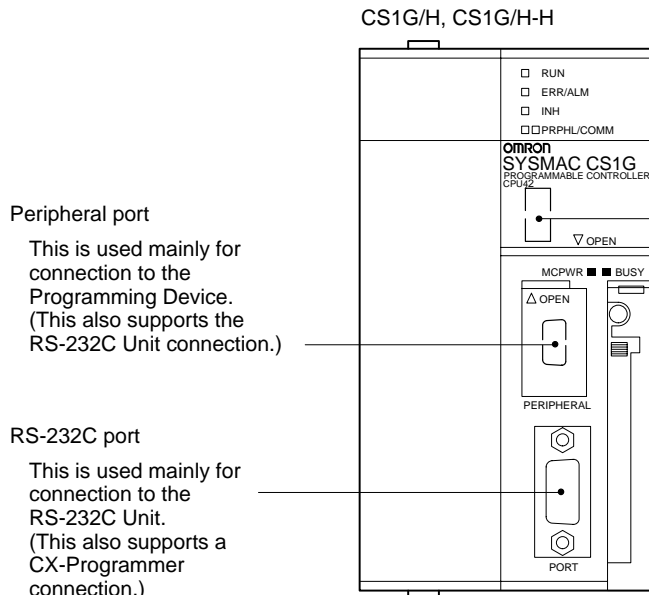

DIP switches (inside the battery storage)

- Set pin 4 to ON (establishing communication in accordance with PC Setup) when connecting the NT21 to the peripheral port.
- Set pin 5 to OFF (establishing communication in accordance with PC Setup) when connecting the NT21 to the RS-232C port.

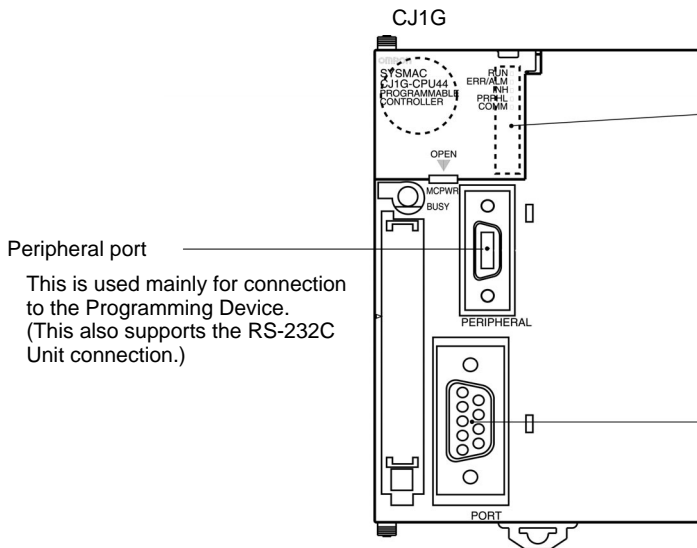

DIP switches (inside the battery storage)

- Set pin 4 to ON (establishing communication in accordance with PC Setup) when connecting the NT21 to the peripheral port.
- Set pin 5 to OFF (establishing communication in accordance with PC Setup) when connecting the NT21 to the RS-232C port.

**Connecting to CS-series Serial Communications Board**

Serial Communications Board equipped with a RS-232C port for CS-series CPU Units: CS1W-SCB41/21

**Allocation DM Area Settings for CPU Unit**

Settings are written from the Programming Device (a Programming Console or CX-Programmer) directly into the allocated DM Area (PC Setup) of the CPU Unit. After the settings are written, they become effective by turning the power ON, restarting the Unit, restarting the communication port, or execution of the STUP instruction.

The following table shows the words allocated in the DM Area and the settings.

Allocated DM word		Value	Settings
Port 1	Port 2		
DM32000	DM32010	8000	Host Link mode, 2 stop bits, even parity, data length 7 bits
DM32001	DM32011	0000	Baud rate 9,600 bps.
		0007	Baud rate 19,200 bps.
DM32002	DM32012	0000	Transmit delay time 0 ms.
DM32003	DM32013	0000	No CTS control Unit No.0 for Host Link

**Using the 1:1 NT Link**

**Compatible Host Units**

Some models and series of OMRON PCs have the 1:1 NT Link function built in. With CQM1H PCs, a Serial Communications Board can be added to provide 1:1 NT Link communications. Some C200HX/HG/HE(-Z)E CPU Units can be connected by the 1:1 NT Link by installing a Communication Board.

Check the model and series of the PC against the model of CPU Unit before making the connections.

The hosts that can be connected to the NT21 by the 1:1 NT Link using the RS-232C ports of both Units are indicated in the table below.

PC Series	CPU Units with Built-in NT Link Function	CPU Units Connectable with Expansion Communication Board <sup>(*)</sup>	Connectable to
C Series	C200HS-CPU21-E, -EC C200HS-CPU23-E C200HS-CPU31-E C200HS-CPU33-E	---	C200HS
	C200HE-CPU42-(Z)E	C200HE-CPU32-(Z)E C200HE-CPU42-(Z)E	C200HE (-Z)E
	C200HG-CPU43-(Z)E C200HG-CPU63-(Z)E	C200HG-CPU33-(Z)E C200HG-CPU43-(Z)E C200HG-CPU53-(Z)E C200HG-CPU63-(Z)E	C200HG (-Z)E
	C200HX-CPU44-(Z)E C200HX-CPU64-(Z)E X200HX-CPU65-ZE C200HX-CPU85-ZE	C200HX-CPU34-(Z)E C200HX-CPU44-(Z)E C200HX-CPU54-(Z)E C200HX-CPU64-(Z)E C200HX-CPU65-ZE C200HX-CPU85-ZE	C200HX (-Z)E
	CPM1-10CDR-□ <sup>(*)2</sup> CPM1-20CDR-□ <sup>(*)2</sup> CPM1-30CDR-□ <sup>(*)2</sup> CPM1A-10CD□-□ <sup>(*)2</sup> CPM1A-20CD□-□ <sup>(*)2</sup> CPM1A-30CD□-□ <sup>(*)2</sup> CPM1A-40CD□-□ <sup>(*)2</sup>	---	CPM1
	CPM2A-30CD□□-□ CPM2A-40CD□□-□ CPM2A-60CD□□-□	---	CPM2A
	CPM2C-10□□□□□□-□ <sup>(*)3</sup> CPM2C-20□□□□□□-□ <sup>(*)3</sup>	---	CPM2C
	CQM1-CPU41-EV1 CQM1-CPU42-EV1 CQM1-CPU43-EV1 CQM1-CPU44-EV1 CQM1-CPU45-EV1	---	CQM1
	CQM1H-CPU21-E CQM1H-CPU51-E CQM1H-CPU61-E	CQM1H-CPU51 <sup>(*)4</sup> CQM1H-CPU61 <sup>(*)4</sup>	CQM1H

PC Series	CPU Units with Built-in NT Link Function	CPU Units Connectable with Expansion Communication Board <sup>(*1)</sup>	Connectable to
CVM1 Series <sup>(*5)</sup>	CVM1-CPU01-EV2 CVM1-CPU11-EV2 CVM1-CPU21-EV2	---	CVM1
CompoBus/S Master Unit	SRM1-C02-V2	---	SRM1

\*1 One of the following Communication Boards is required:  
C200HW-COM02/COM04/COM05/COM06-EV1.

\*2 A CPM1-CIF01 adapter is required.

\*3 Use a CPM2C-CN111 or CS1W-CN114/118 Connecting Cable, CPM1-CIF01 RS-232C Adapter, or CPM1-CIF11 RS-422A Adapter to connect.

\*4 A CQM1H-SCB41 Serial Communications Board is required.

\*5 CPU Units of CVM1/CV-series PCs without the suffix -EV□ cannot be connected.

**Reference:** CS/CJ-series CPU Unit cannot be connected with the 1:1 connection NT link method. Use the 1:N connection NT link method (standard or high-speed) instead of making the 1:1 connection. For details, refer to *Using the 1:N NT Link* (page 55) or *Using the High-speed 1:N NT Link* (page 60).

**Settings at The Host**

The setting methods for each Unit are as follows:

**Connecting to a C-series C200HS, C200HX/HG/HE(-Z)E, CPM1, CPM2A, CPM2C, CQM1, CQM1H, or SRM1**

**PC Setup Settings**

Write the PC Setup (in the DM Area) settings directly from a Programming Device (e.g., SYSMAC Support Software) in accordance with the host model and port.

Host Model	Word	Writing Value	Setting
RS-232C port of C200HS, C200HX/HG/HE(-Z)E, CPM2A, CPM2C, CQM1, CQM1H, SRM1	DM6645	4000	Use 1:1 NT Link
Port A of C200HX/HG/HE(-Z)E <sup>(*1)</sup> Port 1 of CQM1H <sup>(*2)</sup>	DM6555		
Port B of C200HX/HG/HE(-Z)E <sup>(*1)</sup>	DM6550		
CPM1	DM6650		

\*1 RS-232C port of the Communication Board

\*2 RS-232C port of the Serial Communications Board

For details on operations relating to the PC Setup, refer to the manual for the PC that is used.

**Connecting to a CPM2C**

The CPM2C PCs do not have the same kind of port connectors found on CS/CJ-series PCs. The CPM2C's communication port handles both RS-232C and peripheral port connections, which are divided internally. Therefore, when using the CPM2C, it is necessary to select RS-232C or peripheral port connections, according to the kind of cable and port (on the cable) used, as shown in the following table. Refer to the *CPM2C Operation Manual* for more details.

Port connecting to PT	PC Setup
RS-232C port (D-Sub 9-pin) of CPM2C-CN111	Built-in RS-232C port settings
Peripheral port of CPM2C-CN111	Peripheral port settings
RS-232C port (D-Sub 9-pin) of CS1W-CN118	Built-in RS-232C port settings
Peripheral port of CS1W-CN114	Peripheral port settings

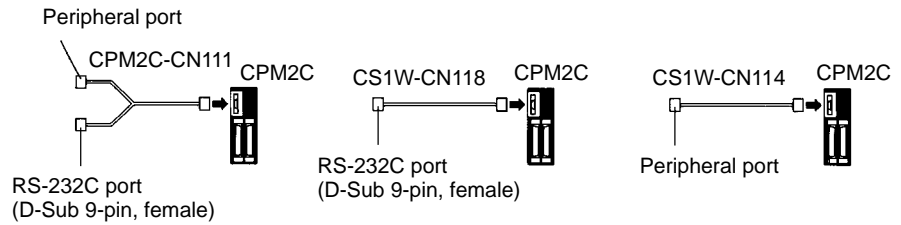

**Setting the DIP Switches on the Front of a C200HX/HG/HE(-Z)E, CQM1, CQM1H**

When using a C200HX/HG/HE(-Z)E, CQM1, or CQM1H, the DIP switches on the front panel must be set as shown below in order to make the settings in the PC Setup (data memory) effective.

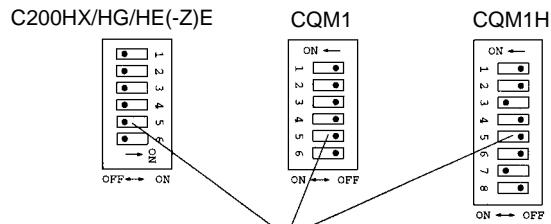

RS-232C port communication condition setting  
Set pin 5 to OFF to make the settings made in PC Setup effective.

**Setting the Switches of a CPM2A**

When using a CPM2A, the switches on the front panel must be set as shown below in order to make the PC Setup settings effective.

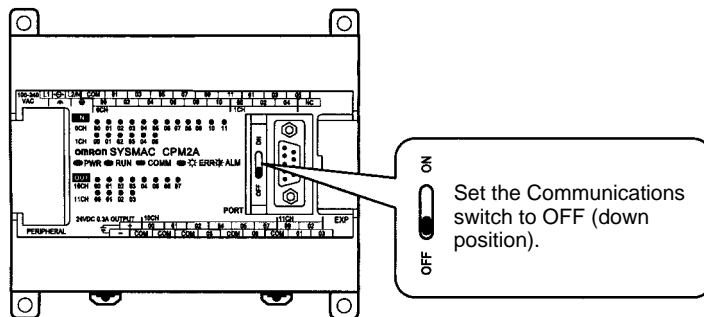



**Setting the Switches of a CPM2C**

When using a CPM2C, the switches on the front panel must be set as shown below in order to make the PC Setup settings effective.

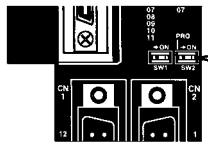

The settings for SW1 and SW2 depend upon the usage of the peripheral port and RS-232C port.

- Connecting PT to peripheral port
- Connecting PT to built-in RS-232C port  
(A device that requires non-standard communications settings is connected to the peripheral port.)

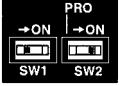

SW1: OFF  
SW2: ON

- Connecting PT to built-in RS-232C port  
(A Programming Console is connected to the peripheral port.)



SW1: OFF  
SW2: OFF

**Setting the Switches on an RS-232C Adapter**

When using a CPM1-CIF01 RS-232C Adapter, set the mode switch as shown in the following diagram.

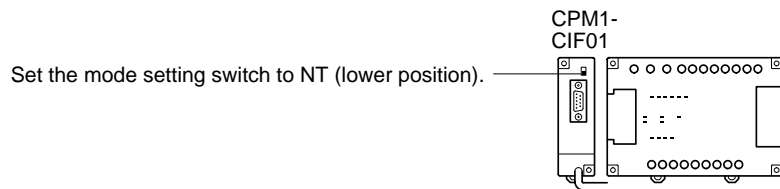

**Connecting to CVM1/CV Series (-EV□)**

Set the DIP switch on the front panel as follows:

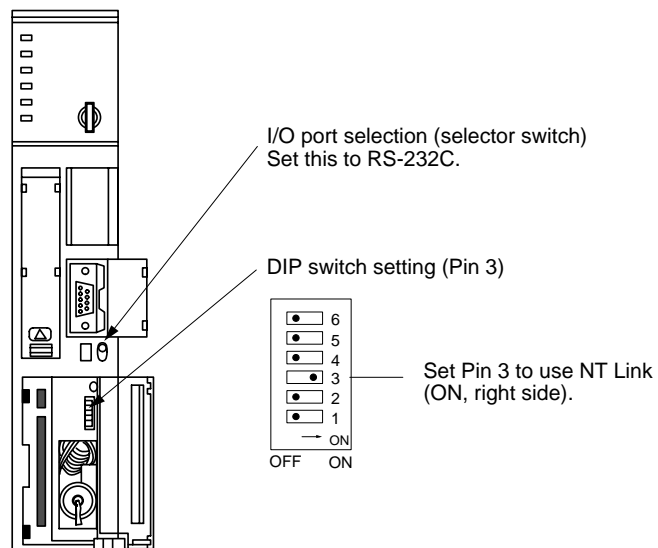

When using a CVM1/CV-series PC, CPU Unit execution processing (execution control 2) in the PC Setup must be set to Simultaneous processing.

## Using the 1:N NT Link

**Compatible Host Units**

The OMRON PCs that can be connected using the 1:N NT Link are the CS-series (CS1G/H or CS1G/H-H), CJ-series CJ1G, C-series C200HX/HG/HE(-Z)E, CQM1H, and SRM1 only. With the CS/CJ-series PCs, it is possible to connect a 1:N NT Link using a CS1W-SCU21 or CJ1W-SCU41 Serial Communications Unit.

Check the model and series of the PC as well as the model of Serial Communications Board or Unit being used before making the connections.

The hosts that can be connected to the NT21 by the 1:N NT Link using the RS-232C ports of both Units are indicated in the table below.

PC Series	CPU Units with Built-in NT Link Function	CPU Units Connectable with Communications Board or Unit <sup>(*1)</sup>	Connectable to
CS Series	CS1G-CPU42/43/44/ 45-EV1	CS1G-CPU42/43/44/ 45-EV1	CS1G CS1H CS1G-H CS1H-H
	CS1H-CPU63/64/65/ 66/67-EV1	CS1H-CPU63/64/65/ 66/67-EV1	
	CS1G-CPU42H/43H/44H/ 45H	CS1G-CPU42H/43H/44H/ 45H <sup>(*1)</sup>	
	CS1H-CPU63H/64H/65H/ 66H/67H	CS1H-CPU63H/64H/65H/ 66H/67H <sup>(*1)</sup>	
CJ Series	CJ1G-CPU44/45	CJ1G-CPU44/45 <sup>(*2)</sup>	CJ1G
C Series	C200HE-CPU42-(Z)E	C200HE-CPU32-(Z)E <sup>(*3)</sup> C200HE-CPU42-(Z)E <sup>(*3)</sup>	C200HE (-Z)E
	C200HG-CPU43-(Z)E C200HG-CPU63-(Z)E	C200HG-CPU33-(Z)E <sup>(*3)</sup> C200HG-CPU43-(Z)E <sup>(*3)</sup> C200HG-CPU53-(Z)E <sup>(*3)</sup> C200HG-CPU63-(Z)E <sup>(*3)</sup>	C200HG (-Z)E
	C200HX-CPU44-(Z)E C200HX-CPU64-(Z)E C200HX-CPU65-ZE C200HX-CPU85-ZE	C200HX-CPU34-(Z)E <sup>(*3)</sup> C200HX-CPU44-(Z)E <sup>(*3)</sup> C200HX-CPU54-(Z)E <sup>(*3)</sup> C200HX-CPU64-(Z)E <sup>(*3)</sup> C200HX-CPU65-ZE <sup>(*3)</sup> C200HX-CPU85-ZE <sup>(*3)</sup>	C200HX (-Z)E
	---	CQM1H-CPU51 <sup>(*4)</sup> CQM1H-CPU61 <sup>(*4)</sup>	CQM1H
CompoBus/S Master Control Unit	SRM1-C02-V2	---	SRM1

\*1 A CS1W-SCB21 or CS1W-SCB41 Serial Communications Board or CS1W-SCU21 Serial Communications Unit is required.

\*2 A CJ1W-SCU41 Serial Communications Unit is required.

\*3 One of the following Communication Boards is required:  
C200HW-COM02/COM04/COM05/COM06 (-EV1)

\*4 A CQM1H-SCB41 Serial Communications Board is required.

**Reference:** The -V1 versions of CS-series PCs and CJ-series PCs support the high-speed 1:N NT Link as well as the standard 1:N NT Link. Furthermore, the high-speed 1:N NT Link can be used in earlier versions of CS-series PCs by installing a new version of Serial Communications Board or Unit. For details, refer to *Using the High-speed 1:N NT Link* (page 60).

**Settings at the Host**

The Settings required for each Unit are described below.

• **Connecting a C-series C200HX/HG/HE(-Z)E, CQM1H, or SRM1**

**PC Setup Settings**

Write the PC Setup (in the DM Area) settings directly from a Programming Device (e.g., SYSMAC Support Software) in accordance with the host model and port.

Connection to	Word	Writing Value	Setting
C200HX/HG/HE(-Z)E, SRM1 Built-in RS-232C port	DM6645	5□00	Use 1:N NT Link □ = largest unit number of the connected PTs (1 to 7) (*3)
C200HX/HG/HE(-Z)E Communication Board port A(*1) CQM1H port 1(*2)	DM6555		
C200HX/HG/HE(-Z)E Communication Board port B(*1)	DM6550		

\*1 RS-232C port on the Communications Board

\*2 RS-232C port on the Serial Communications Board

\*3 When using a C200HE (-Z)E, the maximum PT unit number is 3.

Refer to the PC's operation manual for details on changing PC Setup settings.

**Setting the DIP Switches of a C200HX/HG/HE(-Z)E**

When using a C200HX/HG/HE(-Z)E, the DIP switches on the front panel must be set as shown below in order to make the settings in the PC Setup (in the DM Area) effective.

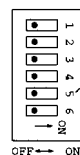

RS-232C port communication condition setting  
Set pin 5 to OFF to make the settings made in PC Setup effective.

**Connecting to CS/CJ-series CPU Units**

CS-series CPU Unit: CS1G/H-CPU□□-E(V1), CS1G/H-CPU□□H

CJ-series CPU Unit: CJ1G-CPU□□

**PC Setup**

When connecting to a CS/CJ-series CPU Unit, set the following communication conditions for the PC Setup, in accordance with the communication port to be used.

When using the built-in RS-232C port of a CS1G/H, CS1G/H-H, or CJ1G

Word	Value	Settings
CIO 160	8200	1:N NT Link mode
CIO 161	0000 to 0009 (*1)	Communications baud rate (standard)
CIO 166	000□	□ = The largest model number of the connected PT (0 – 7)

\*1 Set any value between 0000 and 0009 Hex for the communications baud rate. The same baud rate will be used regardless of the value as long as it is between 0000 and 0009 Hex.

When using the peripheral port of a CS1G/H, CS1G/H-H, or CJ1G

Word	Value	Settings
CIO 144	8200	1:N NT Link mode
CIO 145	0000 to 0009 (*1)	Communications baud rate (standard)
CIO 150	000□	□ = The largest model number of the connected PT (0 – 7)

\*1 Set any value between 0000 and 0009 Hex for the communications baud rate. The same baud rate will be used regardless of the value as long as it is between 0000 and 0009 Hex.

When connecting PTs with model numbers 0 and 2 to 5 to the built-in RS-232C port, for example, set CIO 160 to 8200 Hex, CIO 161 to 0000 Hex and set CIO166 to 0005 Hex.

Either set PC Setup directly from a Programming Device (Programming Console), or transmit the PC Setup made at a Programming Device (CX-Programmer) to the CPU Unit. For details on PC Setup, refer to the *SYSMAC CS Series Operation Manual* (W339-E1-□) or *SYSMAC CJ Series Operation Manual* (W393-E1-□).

**Setting the Front Switches**

Set pins 4 and 5 of the CPU Unit DIP switch in accordance with the port that the NT21 is connected to.

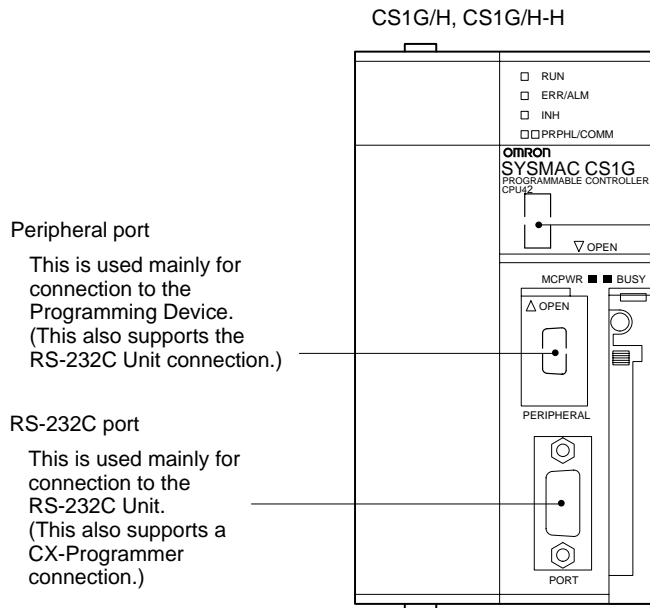

Peripheral port  
This is used mainly for connection to the Programming Device. (This also supports the RS-232C Unit connection.)

RS-232C port  
This is used mainly for connection to the RS-232C Unit. (This also supports a CX-Programmer connection.)

DIP switches (inside the battery storage)

- Set pin 4 to ON (establishing communication in accordance with PC Setup) when connecting the NT21 to the peripheral port.
- Set pin 5 to OFF (establishing communication in accordance with PC Setup) when connecting the NT21 to the RS-232C port.

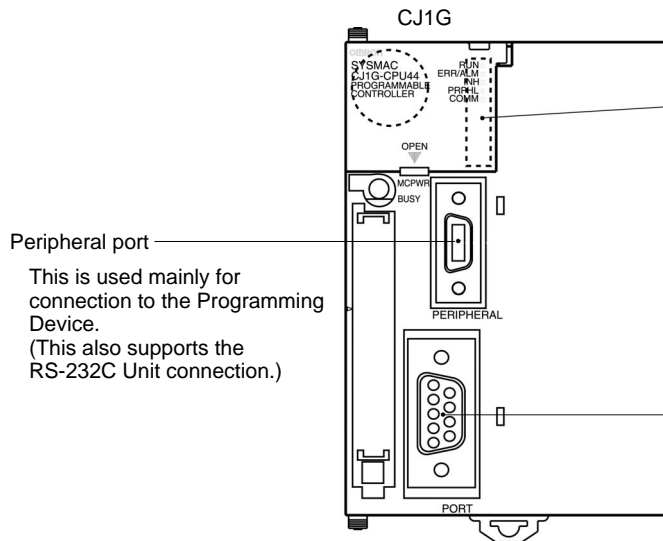

Peripheral port  
This is used mainly for connection to the Programming Device. (This also supports the RS-232C Unit connection.)

DIP switches (inside the battery storage)

- Set pin 4 to ON (establishing communication in accordance with PC Setup) when connecting the NT21 to the peripheral port.
- Set pin 5 to OFF (establishing communication in accordance with PC Setup) when connecting the NT21 to the RS-232C port.

RS-232C port  
This is used mainly for connection to the RS-232C Unit. (This also supports a CX-Programmer connection.)

**Connecting to CS-series Serial Communications Board**

Serial Communications Board equipped with a RS-232C port for CS-series CPU Units: CS1W-SCB41/21

**CPU Unit Allocation DM Area Settings**

Setting is written from the Programming Device (a Programming Console or CX-Programmer) directly into the allocated DM Area (PC Setup) of the CPU Unit. After the setting is written, it becomes effective by turning the power ON, restarting the Unit, restarting the communication port, or execution of the STUP instruction.

The following table shows the words allocated in the DM Area and the settings.

Allocated DM word		Value	Settings
Port 1	Port 2		
DM32000	DM32010	8200	1:N NT Link mode
DM32001	DM32011	0000 to 0009 (*1)	Communications baud rate (standard)
DM32006	DM32016	000□	□ = The largest model number of the connected PT (0 – 7)

\*1 Set any value between 0000 and 0009 Hex for the communications baud rate. The same baud rate will be used regardless of the value as long as it is between 0000 and 0009 Hex.

For example, when connecting PTs with model numbers 3, 4, 5, and 6 to port 1, set DM 32000 to 8200 Hex, DM 32001 to 0000 Hex, and DM 32006 to 0006 Hex.

**Connecting to CS/CJ-series Serial Communications Unit**

A CS-series Rack-mounted Unit: CS1W-SCU21

CJ-series: CJ1W-SCU41 (Port 2 is an RS-232C port.)

**Setting the Front Switches**

Set the unit number of the Serial Communications Unit by using the rotary switch located on the front panel. Set each switch with a flat blade screwdriver so that the values or symbols in the setting value window agree with the following.

CS1W-SCU21

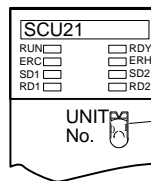

Set the unit number to 0 through F so that it will not duplicate the numbers used in other Units.

CJ1W-SCU41

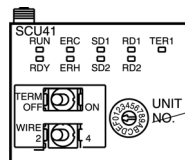

Set the unit number to 0 through F so that it will not duplicate the numbers used in other Units.

**Allocation DM Area Settings for CPU Unit**

Setting is written from the Programming Device (a Programming Console or CX-Programmer) directly into the allocated DM Area (PC Setup) of the CPU Unit. After the setting is written, it becomes effective by turning the power ON, restarting the Unit, restarting the communication port, or execution of the STUP instruction.

The following table shows the words allocated in the DM Area and the settings.

$$m = DM30000 + (100 \times \text{unit number})$$

Allocated DM word		Value	Settings
Port 1	Port 2		
m	m+10	8200	1:N NT Link mode
m+1	m+11	0000 to 0009 (*1)	Communications baud rate (standard)
m+6	m+16	000□	□ = The largest PT model number of the connected PT (0 - 7)

\*1 Set any value between 0000 and 0009 Hex for the communications baud rate. The same baud rate will be used regardless of the value as long as it is between 0000 and 0009 Hex.

**Using the High-speed 1:N NT Links**

**Compatible Host Units**

Only the -V1 versions of the CS1-series CS1G/H, CS1-H-series CS1G/H-H, and CJ-series CJ1G PCs support the high-speed 1:N NT Links directly. Other CS/CJ-series PCs can use the high-speed 1:N NT Links indirectly through a CS1W-SCU21 or CJ1W-SCU41 Serial Communications Unit. (If a Serial Communications Unit is used, even CS1-series Units without the “-V1” suffix can be connected via high-speed 1:N NT Links.)

Be sure to check the model number of the PC and Serial Communications Board/Unit before trying to establish the high-speed 1:N NT Links.

The following table shows which CS1-series PCs can be connected to an NT21 with the high-speed 1:N NT Links.

PC model	CPU Units with Built-in NT Link Function	CPU Units Connectable only through a Serial Communication Board or Unit	Connectable models
CS Series	CS1G-CPU42/43/44/45-EV1 (*1)	CS1G-CPU42/43/44/45-E(V1) (*2)	CS1G
	CS1H-CPU63/64/65/66/67-EV1 (*1)	CS1H-CPU63/64/65/66/67-E(V1) (*2)	CS1H
	CS1G-CPU42H/43H/44H/45H (*1)	CS1G-CPU42H/43H/44H/45H (*2)	CS1G-H
	CS1H-CPU63H/64H/65H/66H/67H (*1)	CS1H-CPU63H/64H/65H/66H/67H (*2)	CS1H-H
CJ Series	CJ1G-CPU44/45	CJ1G-CPU44/45 (*3)	CJ1G

\*1 The direct high-speed 1:N NT Link connection is not supported by CS1-series CPU Units without the -V1 suffix.

\*2 A CS1W-SCB21 or CS1W-SCB41 Serial Communications Board or CS1W-SCU21 Serial Communications Unit is required.

\*3 A CJ1W-SCU41 Serial Communications Unit is required.

**Settings at the Host**

The Settings required for each Unit are described below.

• **Connecting CS/CJ-series CPU Units**

CS-series CPU Unit model: CS1G/H-CPU□□-EV1, CS1G/H-CPU□□H

CJ-series CPU Unit model: CJ1G-CPU□□

**PC Setup**

When connecting to a CS/CJ-series CPU Unit, set the following communication conditions for the PC Setup, in accordance with the communication port to be used.

When using the built-in RS-232C port of a CS1G/H, CS1G/H-H, or CJ1G

Word	Value	Settings
160	8200	1:N NT Link mode
161	000A	Communications baud rate (high-speed)
166	000□	□ = The largest model number of the connected PT (0 – 7)

When using the peripheral port of a CS1G/H, CS1G/H-H, or CJ1G

Word	Value	Settings
144	8200	1:N NT Link mode
145	000A	Communications baud rate (high-speed)
150	000□	□ = The largest model number of the connected PT (0 – 7)

When connecting PTs with model numbers 0, 2, 3, 4, and 5 to the built-in RS-232C port, for example, set CIO 160 to 8200 Hex, CIO 161 to 000A Hex, and CIO166 to 0005 Hex.

Either set PC Setup directly from a Programming Device (Programming Console), or transmit the PC Setup made at a Programming Device (CX-Program-

mer) to the CPU Unit.

For details on PC Setup, refer to the *SYSMAC CS Series Operation Manual* (W339-E1-□) or *SYSMAC CJ Series Operation Manual* (W393-E1-□).

**Reference:** When using the CX-Programmer to set the high-speed 1:N NT Link, set the communications baud rate to 115,200 bps.

**Setting the Front Switches**

Set pins 4 and 5 of the CPU Unit DIP switch in accordance with the port that the NT21 is connected to.

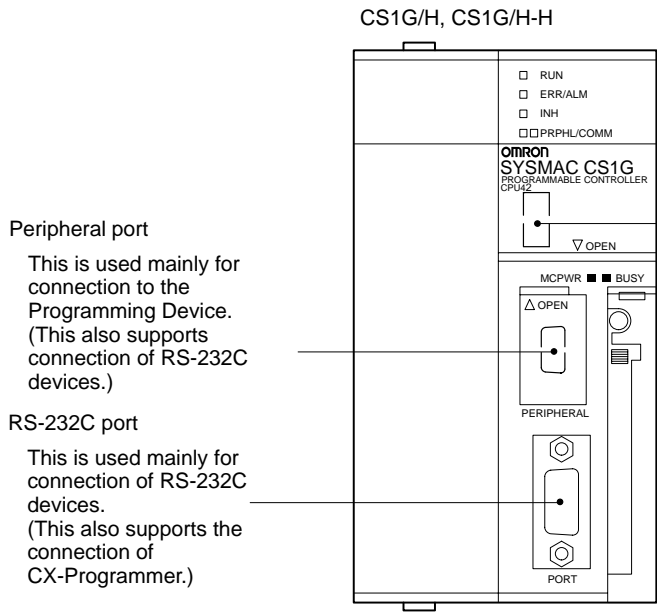

**Peripheral port**  
This is used mainly for connection to the Programming Device. (This also supports connection of RS-232C devices.)

**RS-232C port**  
This is used mainly for connection of RS-232C devices. (This also supports the connection of CX-Programmer.)

- DIP switches (inside the battery storage)
- Set pin 4 to ON (establishing communication in accordance with PC Setup) when connecting the NT21 to the peripheral port.
  - Set pin 5 to OFF (establishing communication in accordance with PC Setup) when connecting the NT21 to the RS-232C port.

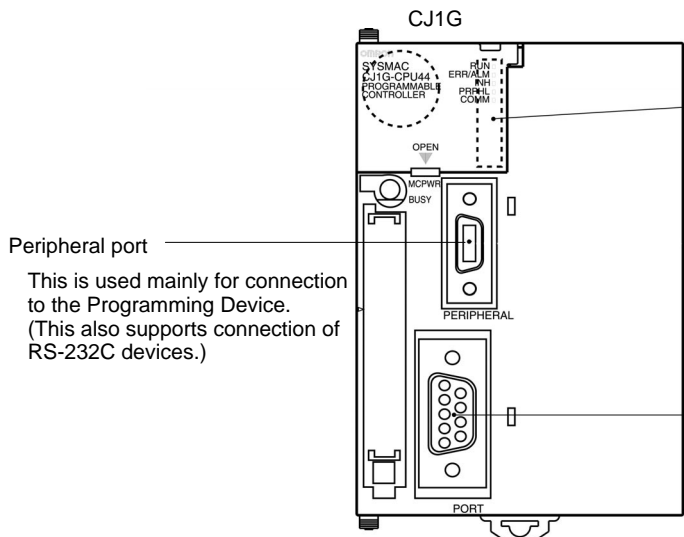

**Peripheral port**  
This is used mainly for connection to the Programming Device. (This also supports connection of RS-232C devices.)

- DIP switches (inside the battery storage)
- Set pin 4 to ON (establishing communication in accordance with PC Setup) when connecting the NT21 to the peripheral port.
  - Set pin 5 to OFF (establishing communication in accordance with PC Setup) when connecting the NT21 to the RS-232C port.

**RS-232C port**  
This is used mainly for connection of RS-232C devices. (This also supports the connection of CX-Programmer.)

**Connecting to a CS-series Serial Communications Board**

Serial Communications Board equipped with a RS-232C port for CS-series CPU Units: CS1W-SCB41/21

**Reference:** Serial Communications Boards and Serial Communications Units with lot number 991220 (12/20/99) and later support the high-speed 1:N NT Link. Boards and Units with earlier lot numbers **cannot** be used.



**CPU Unit Allocation DM Area Settings**

Setting is written from the Programming Device (a Programming Console or CX-Programmer) directly into the allocated DM Area (PC Setup) of the CPU Unit. After the setting is written, it becomes effective by turning the power ON, restarting the Unit, restarting the communication port, or execution of the STUP instruction.

The following table shows the words allocated in the DM Area and the settings.

Allocated DM word		Value	Settings
Port 1	Port 2		
DM32000	DM32010	8200	1:N NT Link mode
DM32001	DM32011	000A	Communications baud rate (high-speed)
DM32006	DM32016	000□	□ = The largest model number of the connected PT (0 – 7)

For example, when connecting PTs with model numbers 3, 4, 5, and 6 to port 1, set DM 32000 to 8200 Hex, DM 32001 to 000A Hex, and DM 32006 to 0006 Hex.

**Connecting to a CS/CJ-series Serial Communications Unit**

A CS-series Rack-mounted Unit: CS1W-SCU21

CJ-series: CJ1W-SCU41 (Port 2 is an RS-232C port.)

**Reference:** Serial Communications Boards and Serial Communications Units with lot number 991220 (12/20/99) and later support the high-speed 1:N NT Link. Boards and Units with earlier lot numbers **cannot** be used.

**Setting the Front Switches**

Set the unit number of the Serial Communications Unit by using the rotary switch located on the front panel. Set each switch with a flat blade screwdriver so that the values or symbols in the setting value window agree with the following.

CS1W-SCU21

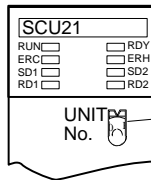

Set the unit number to 0 through F so that it will not duplicate the numbers used in other Units.

CJ1W-SCU41

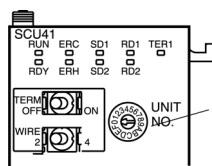

Set the unit number to 0 through F so that it will not duplicate the numbers used in other Units.

**Allocation DM Area Settings for CPU Unit**

Setting is written from the Programming Device (a Programming Console or CX-Programmer) directly into the allocated DM Area (PC Setup) of the CPU Unit. After the setting is written, it becomes effective by turning the power ON, restarting the Unit, restarting the communication port, or execution of the STUP instruction.

The following table shows the words allocated in the DM Area and the settings.

$$\text{Word } m = \text{DM30000} + 100 \times \text{unit number}$$

Allocated DM word		Value	Settings
Port 1	Port 2		
m	m+10	8200	1:N NT Link mode
m+1	m+11	000A	Communications baud rate (high-speed)
m+6	m+16	000□	□ = The largest model number of the connected PT (0 - 7)

**When Using the Memory Link Method**

In the memory link method, the connection can be made to a personal computer with RS-232 and an FA computer, etc.

When connecting to the host in the memory link method, it is necessary to create a program for the memory link at the host side.

The following are the communication conditions that can be used in the memory link method. For the host (a personal computer, an FA computer, etc.), its setting should be compatible to one of the communication conditions listed in the following table. Set the same communication conditions at the NT21 by the memory switch. (page 132).

Item	Settings at the host
Input/Output port	RS-232C
Baud rate	1,200, 2,400, 4,800, 9,600, 19,200, or 38,400 bps.
Data bits	7 bits, 8 bits
Stop bits	1 bits, 2 bits
Parity	None, even, odd
Flow control	None, RS/CS, XON/XOFF

**4-1-2 Connecting Directly between RS-232C Ports**

The method for connection between the RS-232C ports of the NT21 and the host is described here.

**Recommended Connector Cable**

When making the connector cable, as far as possible use the recommended connectors, connector hoods, and cables indicated in the table below. Some Units come supplied with one connector and one connector hood.

Check the required components and prepare them in advance.

Name	Model	Remarks	Delivered with
Connector	XM2A-0901	9-pin Made by OMRON	CS-series CS1G/CS1H, CS1G-H/CS1H-H CJ-series CJ1G C-series CQM1, C200HS, C200HX/HG/HE(-Z)E, CVM1/CV-series CPU Units CV500-LK201
	XM24-2501	25-pin Made by OMRON	CV500-LK201 C200H-LK201-EV1

Name	Model	Remarks	Delivered with
Connector hood	XM2S-0911	9-pin Made by OMRON	C-series CQM1, C200HS, C200HX/HG/HE-(Z)E, CVM1/CV-series CPU Units CV500-LK201
	XM2S-0913	9-pin Made by OMRON	---
	XM2S-0911-E	9-pin Made by OMRON	CS-series CS1G/CS1H, CS1G-H/CS1H-H CJ-series CJ1G
	XM2S-2511	25-pin Made by OMRON	CV500-LK201 C200H-LK201-EV1
Cable	AWG28 × 5P IFVV-SB	Multi-core shielded cable Made by Fujikura, Ltd.	---
	CO-MA-VV-SB 5P × 28AWG	Multi-core shielded cable Made by Hitachi Cable, Ltd.	---

**Note** After connecting a communication cable, always secure it with the screws. Otherwise the cable may disconnect, causing operation to fail.

#### **OMRON Cables with Connectors**

The OMRON cables listed below can be used when connecting with a method other than the memory link method.

Model	Cable Length	Connector Specification
XW2Z-200S	2 m	9-pin ↔ 25 pin
XW2Z-500S	5 m	
XW2Z-200T	2 m	9-pin ↔ 9-pin
XW2Z-500T	5 m	

The OMRON cable listed below can be used when connecting to a personal computer with the memory link method.

Model	Cable Length	Connector Specification
XW2Z-S002	2 m	9-pin ↔ 9 pin

**Note** The cable's tensile load is 30 N. Do not subject it to loads greater than this. Otherwise a discontinuity may occur, causing operation to fail.

#### **Wiring for a Host Link Unit (25-pin) Connection**

Applicable Units: C200H-LK201-EV1  
CV500-LK201 (communication port 1)

Compatible cables with attached connectors:

XW2Z-200S (9-pin ↔ 25-pin, 2 m)

XW2Z-500S (9-pin ↔ 25-pin, 5 m)

CVM1/CV-series Host Link Units (CV500-LK201) have two types of connector; a 25-pin connector (communication port 1), and a 9-pin connector (communica-



Compatible cables with attached connectors:

XW2Z-200T (9-pin ⇔ 9-pin, 2 m)

XW2Z-500T (9-pin ⇔ 9-pin, 5 m)

CPU Units of CVM1/CV-series PCs without the suffix -EV□ cannot be connected by any connection method.

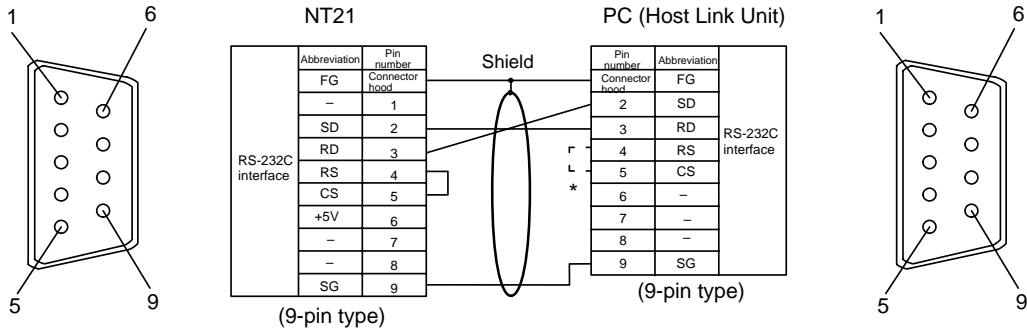

**Wiring for a Memory Link Connection**

Compatible cables with attached connectors:

XW2Z-S002 (9-pin⇔9-pin, 2 m)

Prepare the adapter cable while referring to the following diagram.

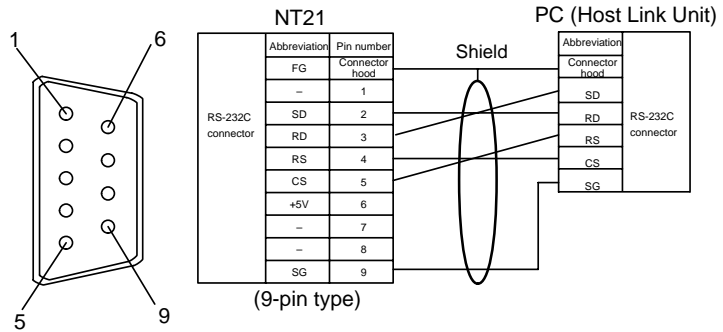

# SECTION 5

## Connecting to the Host from the RS-422A/485 Port

This section describes how to connect to the host using RS-422A/485 cable. Link Adapters convert communication signals between RS-232C cable and RS-422A/RS-485 cable.

5-1	Connecting to the Host's RS-422A/485 Port .....	68
5-1-1	Host Types and Settings .....	69
5-1-2	Direct 1:1 Connection to the Host's RS-422A .....	85
5-1-3	Direct 1:1 Connection to the Host's RS-485 .....	88
5-1-4	1:N Connection to the Host's RS-422A Port .....	89
5-1-5	1:N Connection to the Host's RS-485 Port .....	92
5-1-6	Recommended Connectors, Cables and Crimp Terminals .....	94
5-2	Connecting to the Host's RS-232C Port .....	94
5-2-1	Host Types and Settings .....	95
5-2-2	1:N Connection Using the Host's RS-232C Port .....	95
5-2-3	Recommended Connectors, Cables, and Crimp Terminals .....	99

## 5-1 Connecting to the Host's RS-422A/485 Port

This section explains how to connect to the host's RS-422A/485 port through an RS-422A/485 cable. There are 4 ways to connect through RS-422A/485 cable.

This explanation focuses on connections to OMRON PCs, although any RS-422A device can be connected using the memory link method.

- Method 1

This is a 1:1 connection between the PT's RS-232C port and host's RS-422A terminals (using RS-422A cable) through a Link Adapter. The communications cable can be extended up to 500 m long with this method.

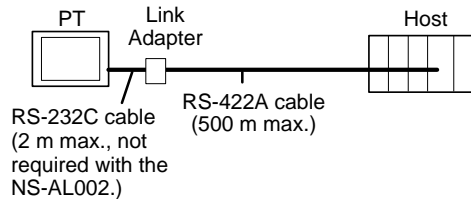

- Method 2

This is a 1:1 connection between the PT's RS-232C port and host's RS-485 terminals (using RS-485 cable) through a Link Adapter. The communications cable can be extended up to 500 m long with this method.

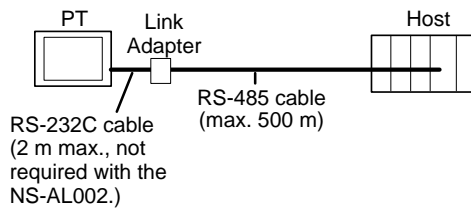

- Method 3

This is a 1:N connection between the RS-232C ports on several PTs and the host's RS-422A terminals (using RS-422A cable) through Link Adapters. The communications cable can be up to 500 m long with this method.

This connection method can only be used with the 1:N NT Link (standard or high-speed).

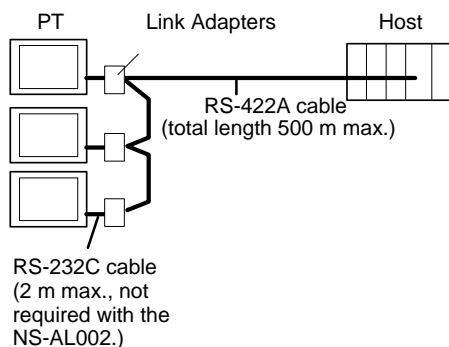

- Method 4

This is a 1:N connection between the RS-232C ports on several PTs and the host's RS-485 terminals (using RS-485 cable) through Link Adapters. The

communications cable can be up to 500 m long with this method. This connection method can only be used with the 1:N NT Link (standard or high-speed).

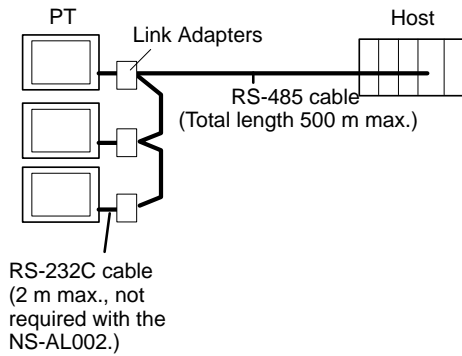

**Note** One end of the wire must always be connected to the host (PC), and there must be no branching. Branching will cause problems such as transmission delays and communication failures.

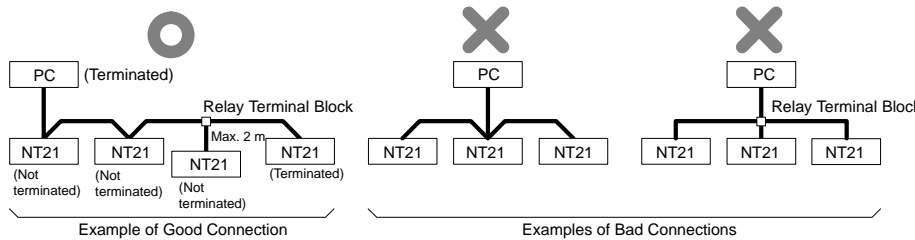

**Reference:** CS/CJ-series CPU Units cannot be connected with the 1:1 connection NT link method. Use the 1:N connection NT link method (standard or high-speed) instead of making the 1:1 connection. For details, refer to *Using the 1:N NT Link Method* (page 80) or *Using the High-speed 1:N NT Link Method* (page 83).

### 5-1-1 Host Types and Settings

This section lists the hosts that have RS-422A ports that can be connected to a PT and describes the settings required at the host.

#### When Using the Host Link Method

##### Compatible Host Units

Some models and series of OMRON PCs have the RS-422A type Host Link function built in. With a CS series, CJ series, and CQM1H Board or Unit, and CQM1H, the Host Link method can be used by installing a Serial Communications Board. In addition, some C200HX/HG/HE(-Z)E devices have an integral CPU Unit that can be connected in the Host Link method by installing a Serial Communications Board.

With the CPM2A and CPM2C, an RS-422A type of 1:1 NT Link can be connected through a CPM1-CIF11 RS-422A Adapter.

Check the model and series of the PC and the type of the installed Board or Unit before making a connection.



The following table lists the Units that are equipped with an RS-422A Host Link function compatible with the NT21.

PC Series	Units with Built-in Host Link Function		CPU Units Connectable with Host Link Units or Expansion Serial Communications Board	Connectable to
	Host Link Unit / Serial Communications Board	CPU Unit		
CS Series	CS1W-SCB41-E	---	CS1G-CPU42/43/44/45-EV1 CS1H-CPU63/64/65/66/67-EV1 CS1G-CPU42H/43H/44H/45H CS1H-CPU63H/64H/65H/66H/67H	CS1G CS1H CS1G-H CS1H-H
CJ Series	CJ1W-SCU41	---	CJ1G-CPU44/45	CJ1G
C Series	C200H-LK202-V1	---	C200HS-CPU01/03/21/23/31/33-E C200HS-CPU01/21-EC C200HE-CPU11/32/42-E C200HE-CPU11/32/42-ZE C200HG-CPU33/43/53/63-E C200HG-CPU33/43/53/63-ZE C200HX-CPU34/44/54/64-E C200HX-CPU34/44/54/64/65/85-ZE	C200HS C200HE C200HE-ZE C200HG C200HG-ZE C200HX C200HX-ZE
	C200HW-COM03/06-EV1	---	C200HE-CPU32/42-E C200HE-CPU32/42-ZE	C200HE C200HE-ZE
			C200HG-CPU33/43/53/63-E C200HG-CPU33/43/53/63-ZE	C200HG C200HG-ZE
			C200HX-CPU34/44/54/64-E C200HX-CPU34/44/54/64/65/85-ZE	C200HX C200HX-ZE
	---	CPM1-10/20/30CDR-□ +CPM1-CIF11	---	CPM1
	---	CPM1A-10/20/30/40CD□-□ +CPM1-CIF11	---	CPM1
	---	CPM2A-30/40/60CD□-□ +CPM1-CIF11 (Peripheral port connection)	---	CPM2A
---	CPM2C-10/20□□□□□□-□ (*1)	---	CPM2C	
	CQM1H-SCB41	---	CQM1H-CPU51/61	CQM1H
CVM1 Series (*2)	CV500-LK201	CVM1-CPU01-EV2 CVM1-CPU11-EV2 CVM1-CPU21-EV2	CVM1-CPU01-EV2 CVM1-CPU11-EV2 CVM1-CPU21-EV2	CVM1
SRM1	---	SRM1-C02-V1+CPM1-CIF11	---	SRM1

\*1: Use a CPM2C-CN111 or CS1W-CN114/118 Connecting Cable, CPM1-CIF01 RS-232C Adapter, or CPM1-CIF11 RS-422A Adapter to connect.

\*2: CPU Units of CVM1/CV-series PCs without the suffix -EV□ cannot be connected.

The Host Link method cannot be used when an NT21 is connected using RS-485. To use the Host Link method, connect by RS-422A.

**Settings at the Host**

When using the RS-422A type Host Link method, the settings shown below must be made at the host (depending on the Unit, some of these settings may not be necessary, or settings not shown here may be necessary).

Item	Setting at Host
I/O port	RS-422A
Baud rate	Set the same baud rate as for the NT21. (*1)
Transfer code	ASCII, 7 data bits, 2 stop bits
Parity	Even
1-to-1/1-to-N	1-to-N(*2)
Command level	Level 1, 2, 3
Unit #	00

- \*1 Set the Host Link baud rate at 9,600 bps or 19,200 bps with the Comm. Speed memory switch at the NT21. For details, refer to *Setting the Host Link Method* (page 125).
- \*2 The 1-to-N setting enables BCC (Block Check Character). It is not actually possible to connect more than one NT21 in a single Host Link.

The setting methods for each model of Unit are described below.

**Connecting to a C-series Host Link Unit**

**C200H/C200HS/C200HE(-Z)E/C200HG(-Z)E/C200HX(-Z)E**

**Rack-mounting model: C200H-LK201-V1**

**Setting the Front Switches**

Set each switch with a flat blade screwdriver so that the values or symbols in the setting value window agree with the following:

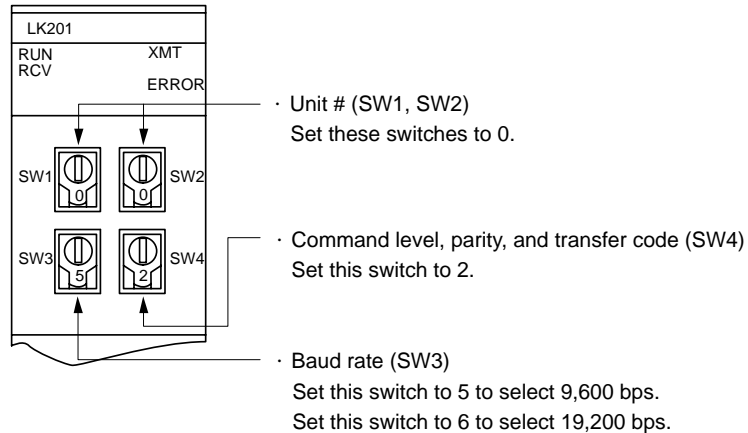

**Setting the Rear Switches**

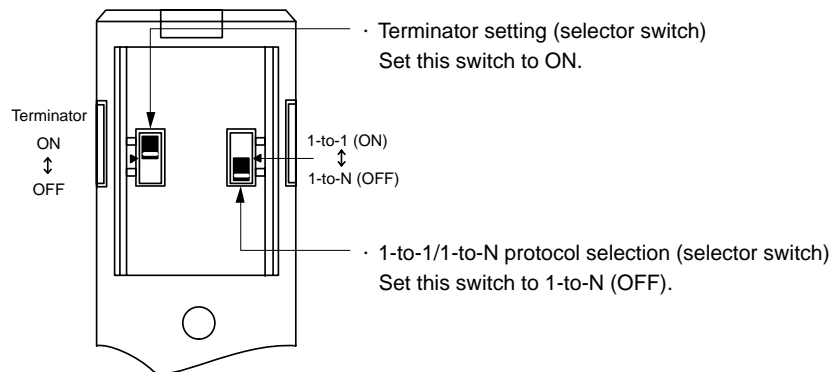

**Connecting to a CVM1/CV-series Host Link Unit**

**CVM1/CV-series Rack-mounting model: CV500-LK201**

A CVM1/CV-series Host Link Unit (CV500-LK201) has two connectors (communication ports 1 and 2). To use the RS-422A type Host Link method, set communication port 2 to RS-422A.

Communication port 2 is a 9-pin connector that allows selection of the RS-232C or RS-422A method. When this port is used with the RS-422A method, the I/O port selector switch on the front of the Unit must be set to RS-422A (the lower position).

**CPU Bus Unit Settings**

When connecting to a CVM1/CV-series Host Link Unit, set the following communication conditions for the CPU Bus Unit settings.

Item	Setting at Host
Baud rate	Set the same speed as for the NT21. (*1)
Transfer code	ASCII, 7 data bits, 2 stop bits

Item	Setting at Host
Parity	Even
1-to-1/1-to-N	1-to-N(*2)
Command level	Level 1, 2, 3

\*1 Set the Host Link baud rate at 9,600 bps or 19,200 bps with the Comm. Speed memory switch at the NT21. For details, refer to *Setting the Host Link Method* (page 125).

\*2 The 1-to-N setting enables BCC (Block Check Character). It is not actually possible to connect more than one NT21 in a single Host Link.

Set the CPU Bus Unit settings directly from a Programming Device (e.g., SYSMAC Support Software).

For details on the CPU Bus Unit settings, refer to the *SYSMAC CVM1/CV-series Host Link Unit Operation Manual* (W205-E1-□).

**Setting the Front Switches**

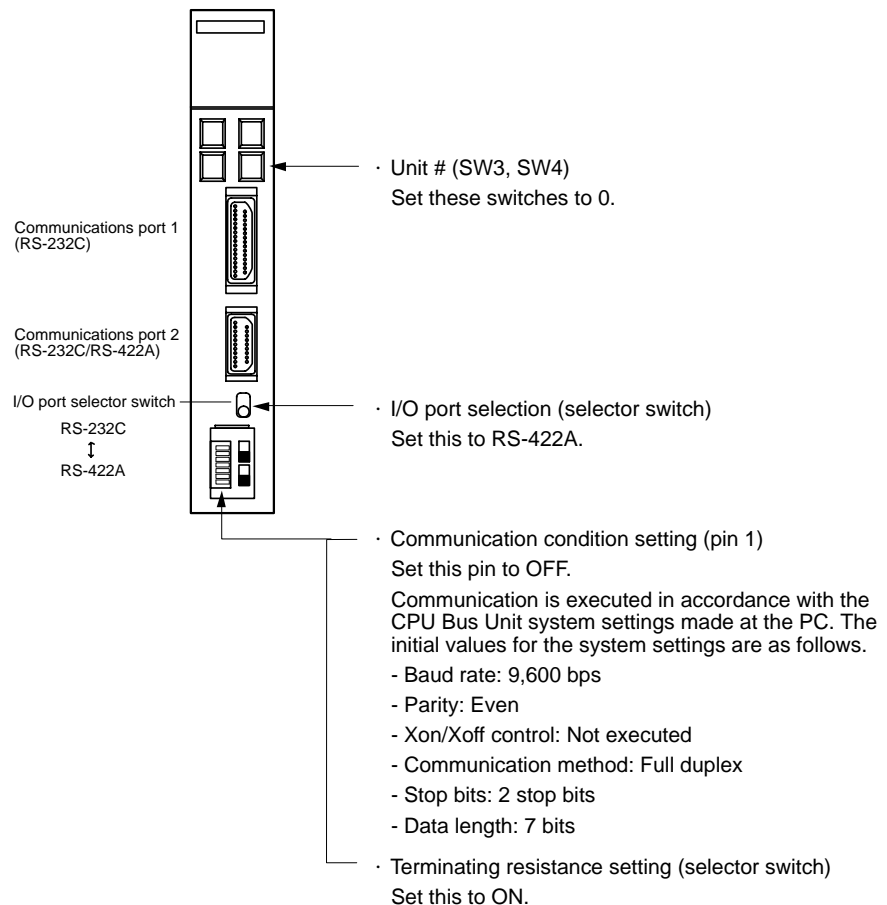

**Connecting to a CJ-series Serial Communications Unit**

**CJ-series: CJ1W-SCU41 (Port 1 is an RS-422A/485 port.)**

**Setting the Front Switches**

Set the unit number of the Serial Communications Unit with the rotary switch on the front of the Unit. Set the unit number with a flat blade screwdriver. Also, set

the communications mode switch to select 4-wire (RS-422A) communications and turn ON the terminator switch to enable the terminating resistance.

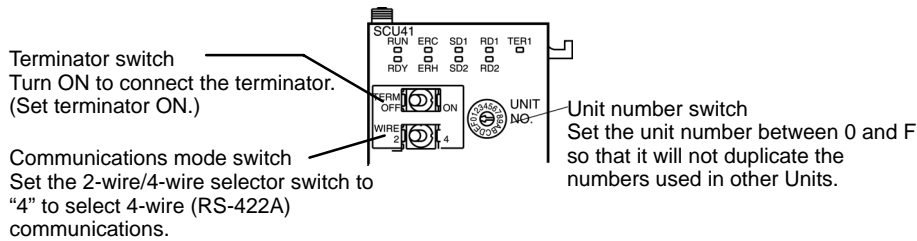

**Allocation DM Area Settings for CPU Unit**

Settings are written from the Programming Device (a Programming Console or CX-Programmer) directly into the allocated DM Area (PC Setup) of the CPU Unit. After the settings are written, they become effective by turning the power ON, restarting the Unit, restarting the communication port, or execution of the STUP instruction.

The following table shows the words allocated in the DM Area and the settings.

$$m = DM30000 + 100 \times \text{unit number}$$

Allocated DM word	Value	Settings
<b>Port 1</b>		
m	8000	Host Link mode, 2 stop bits, even parity, data length 7 bits
m+1	0000	Baud rate 9,600 bps.
	0007	Baud rate 19,200 bps.
m+2	0000	Transmit delay time 0 ms.
m+3	0000	No CTS control Unit No.0 for Host Link

**Connecting to a CPU Unit**

**CVM1/CV-series (-EV□) CPU Units**

CVM1-CPU01-EV2/CVM1-CPU11-EV2/CVM1-CPU21-EV2

**PC Setup**

When connecting to a CVM1/CV-series CPU Unit, set the following communication conditions for the PC Setup.

Item	Setting at Host
Baud rate	Set the same baud rate as for the NT21. (*1)
Stop bits	2 stop bits
Parity	Even
Data length	ASCII 7 bits
Unit #	00

\*1 Set the Host Link baud rate at 9,600 bps or 19,200 bps with the Comm. Speed memory switch at the NT21. For details, refer to *Setting the Host Link Method* (page 125).

Set the PC Setup directly from a Programming Device (e.g., SYSMAC Support Software).

For details on the PC Setup, refer to the *SYSMAC CVM1/CV500/CV1000/CV2000 Operation Manual: Ladder Diagrams (W202-E1-□)*.

**Setting the Front Switches**

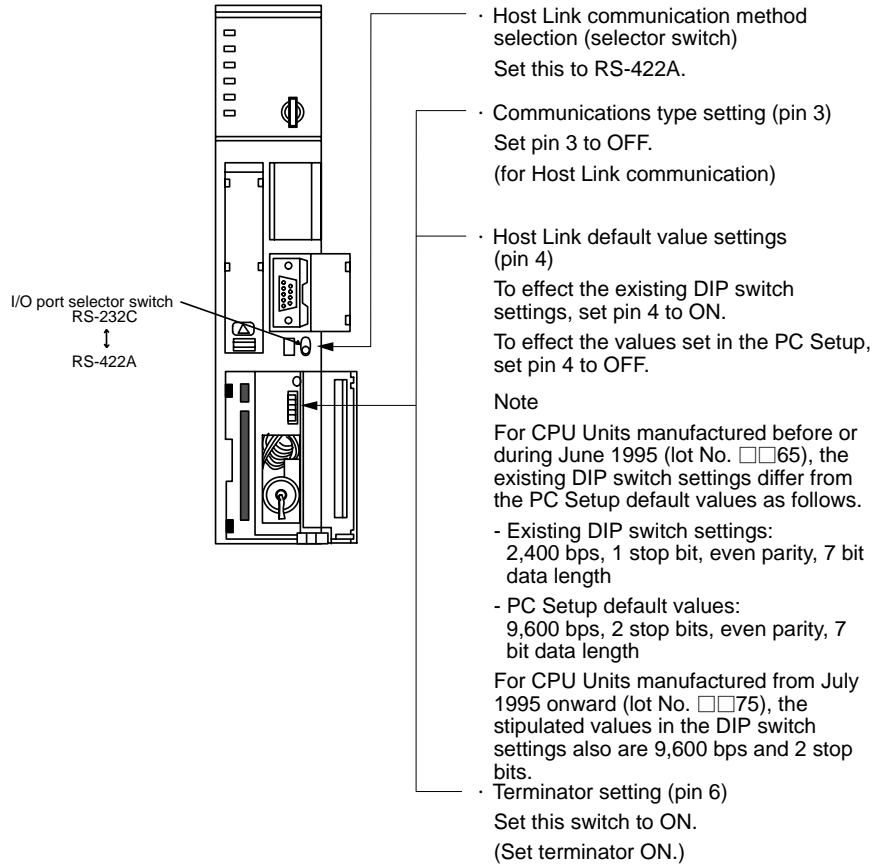

**C200HX/HG/HE(-Z)E, CPM1, CPM2A, CPM2C, CQM1H, or SRM1**

The connection method depends upon the model of PC being used, as shown in the following table.

PC model	Connection method
C200HX/HG/HE(-Z)E	<ul style="list-style-type: none"> <li>• Connect to the RS-422A port (port A) on a Serial Communications Board.</li> </ul>
CQM1H	<ul style="list-style-type: none"> <li>• Connect to the RS-422A port (port 2) on a Serial Communications Board.</li> </ul>
CPM1	<ul style="list-style-type: none"> <li>• Connect to the peripheral port through a CPM1-CIF11 RS-422A Adapter.</li> </ul>
CPM2A, SRM1	<ul style="list-style-type: none"> <li>• Connect to the peripheral port through a CPM1-CIF11 RS-422A Adapter.</li> </ul>
CPM2C	<ul style="list-style-type: none"> <li>• Connect to the peripheral port (on a CPM2C-CN111 or CS1W-CN114 Connecting Cable) through a CPM1-CIF11 RS-422A Adapter.</li> </ul> <p>(The CPM2C-CN111 splits the Unit's Communication Port into a RS-232C port and a peripheral port.)</p>

- Reference:**
- There are no Serial Communications Boards for the C200HX/HG/HE(-Z)E in which port B is the RS-422A port.
  - There are no Serial Communications Boards for the CQM1H in which port 1 is the RS-422A port.

**PC Setup Settings**

When connecting to a C200HX/HG/HE(-Z)E or CPM1, CPM2A, CPM2C,

CQM1H CPU Units or SRM1, set the following communication conditions for the PC Setup.

Item	Setting at Host
I/O port	RS-422A
Communication mode	Host Link mode
Baud rate	Set the same baud rate as for the NT21. (*1)
Stop bits	2 stop bits
Parity	Even
Data length	ASCII 7 bits
Unit #	00

\*1 Set the Host Link baud rate at 9,600 bps or 19,200 bps with the Comm. Speed at the NT21. For details, refer to *Setting the Host Link Method* (page 125).

Set the PC Setup settings directly from a Programming Device (e.g., CX-Programmer).

For details on operations relating to the PC Setup, refer to the manual for the PC that is used.

The PC Setup addresses and settings to be made depending on the Unit to which the connection is made are shown below.

When using port A of the Serial Communications Board of C200HX/HG/HE(-Z)E

Word	Writing Value	Settings
DM6555	0001	Host Link mode, no CTS control Communication conditions set by the contents of DM
DM6556	0303	Data length 7 bits, 2 stop bits, even parity, baud rate: 9,600 bps
	0304	Data length 7 bits, 2 stop bits, even parity, baud rate: 19,200 bps
DM6558	0000	Unit # 00

When using a CPM1, CPM2A, CPM2C, SRM1

Word	Writing Value	Settings
DM6650	0001	Host Link mode, no CTS control Communication conditions set by the contents of DM
DM6651	0303	Data length 7 bits, 2 stop bits, even parity, baud rate: 9,600 bps
	0304	Data length 7 bits, 2 stop bits, even parity, baud rate: 19,200 bps
DM6653	0000	Unit # 00

When using a CQM1H

Word	Writing Value	Settings
DM6550	0001	Host Link mode, no CTS control Communication conditions set by the contents of DM
DM6551	0303	Data length 7 bits, 2 stop bits, even parity, baud rate: 9,600 bps
	0304	Data length 7 bits, 2 stop bits, even parity, baud rate: 19,200 bps
DM6553	0000	Unit # 00

**Connecting to a CPM2C**

Only the CPM2C PCs do not have the same kind of port connectors found on CS/CJ-series PCs. The CPM2C's communication port handles both RS-232C and peripheral port connections, which are divided internally. Therefore, when using the CPM2C, it is necessary to select RS-232C or peripheral port connections, according to the kind of cable and port (on the cable) used, as shown in the following table. Refer to the *CPM2C Operation Manual* for more details.

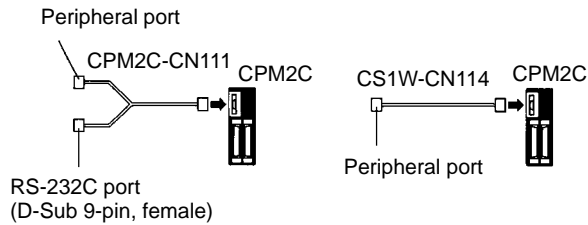

**Setting Switches on a C200HX/HG/HE(-Z)E Serial Communications Board**

Set the switches on a C200HX/HG/HE(-Z)E Serial Communications Board as follows.

- Switch 1: Set to 4 (4-wire, for RS-422A)
- Switch 2: Set to ON for terminator ON (terminating resistance applied)

**Setting Switches on a CQM1H Serial Communications Board**

Set the switches on a CQM1H Serial Communications Board as follows.

- Wire selection (WIRE): Set to 4 (4-wire, for RS-422A)
- Terminator (TERM): Set to ON for termination ON.

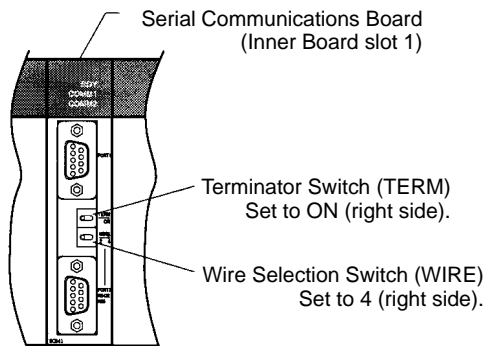

**Setting the Switches on an RS-422A Adapter**



**Connecting to a CS-series Serial Communications Board**

Serial Communications Board with RS-422A/485 port equipped for CS-series CPU Unit Model:

CS1W-SCB41 (The port 2 is RS-422A/485 port.)

Setting the Front Switches

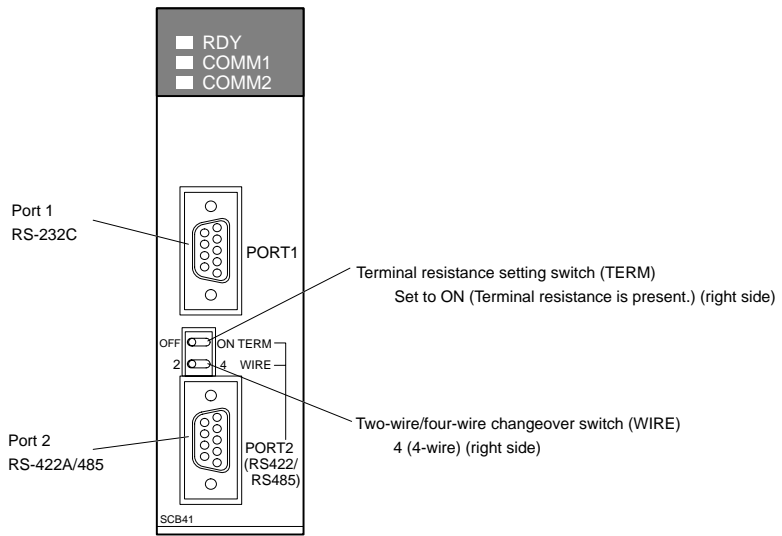

Allocated DM Area Settings for CPU Unit

Settings are written from the Programming Device (a Programming Console or CX-Programmer) directly into the allocated DM Area settings (PC Setup) of the CPU Unit. After the settings are written, they become effective by turning the power ON, restarting the Unit, restarting the communication port, or executing the STUP instruction.

The following table shows the words allocated in the DM Area and the settings.

Allocated DM word	Value	Settings
<b>Port 2</b>		
DM32010	8000	Host Link mode, 2 stop bits, data length 7 bits, even parity,
DM32011	0000	Baud rate 9,600 bps.
	0007	Baud rate 19,200 bps.
DM32012	0000	Transmit delay time 0 ms.
DM32013	0000	No CTS control Unit No.0 for Host Link

Using the 1:1 NT Link Method

Compatible Host Units

Some models and series of OMRON PCs have the RS-422A 1:1 NT Link function built in.

- The C200HX/HG/HE(-Z)E CPU Units can be connected by the RS-422A 1:1 NT Link method by installing a Serial Communications Board.
- The CQM1H CPU Units can be connected by the RS-422A 1:1 NT Link method by installing a Serial Communications Board.

Check the model and series of the PC and the type of installed Serial Communications Board before making connections.



The following table lists the Units that are equipped with an RS-422A 1:1 NT Link function compatible with the NT21.

PC Series	CPU Units with Built-in RS-422A 1:1 NT Link Function	Model Name	
C Series	C200HE-CPU32-(Z)E <sup>(*1)</sup> C200HE-CPU42-(Z)E <sup>(*1)</sup>	C200HE (-Z)E	
	C200HG-CPU33-(Z)E <sup>(*1)</sup> C200HG-CPU43-(Z)E <sup>(*1)</sup> C200HG-CPU53-(Z)E <sup>(*1)</sup> C200HG-CPU63-(Z)E <sup>(*1)</sup>	C200HG (-Z)E	
	C200HX-CPU34-(Z)E <sup>(*1)</sup> C200HX-CPU44-(Z)E <sup>(*1)</sup> C200HX-CPU54-(Z)E <sup>(*1)</sup> C200HX-CPU64-(Z)E <sup>(*1)</sup> C200HX-CPU65-ZE <sup>(*1)</sup> C200HX-CPU85-ZE <sup>(*1)</sup>	C200HX (-Z)E	
	CQM1H-CPU51/61 <sup>(*2)</sup>	CQM1H	
	CVM1 Series <sup>(*3)</sup>	CVM1-CPU01-EV2 CVM1-CPU11-EV2 CVM1-CPU21-EV2	CVM1

\*1 One of the following Serial Communications Boards is required:  
C200HW-COM03-EV1 or C200HW-COM06-EV1.

\*2 A CQM1H-SCB41 Serial Communications Board is required.

\*3 CPU Units of CVM1/CV-series PCs without the suffix -EV□ cannot be connected.

The 1:1 NT Link method cannot be used using RS-485. To use the 1:1 NT Link method, connect by RS-422A.

NT link connection using RS-422A/485 is not possible with the CPM1, CPM2A, and CPM2C.

#### **Settings at the Host**

The setting methods for each model of Unit are described below.

- Connecting to a CVM1/CV-series (-EV□) CPU Units

CVM1-CPU01-EV2/CVM1-CPU11-EV2/CVM1-CPU21-EV2

#### **PC Setup**

When connecting to the CVM1/CV-series CPU Unit by the 1:1 NT Link method, no particular settings are required at the PC Setup.

**Setting the Front Switches**

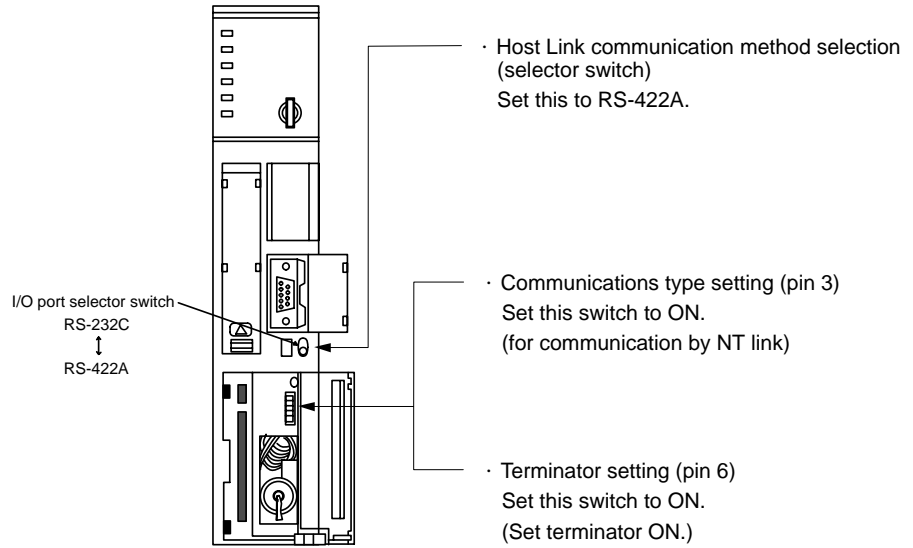

**Connecting to a C-series C200HX/HG/HE(-Z)E or CQM1H**

**PC Setup Settings**

Write the PC Setup (data memory) settings directly from a Programming Device (e.g., CX-Programmer) in accordance with the host model.

Host Model	Word	Writing Value	Setting
Port A of C200HX/HG/HE(-Z)E*1	DM6555	4000	Use 1:1 NT Link
Port 2 of CQM1H*2	DM6550	4000	

\*1 RS-422A port of the Serial Communications Board

\*2 RS-422A port of the Serial Communications Board

For details on operations relating to the PC Setup, refer to the manual for the PC you are using.

**Setting the DIP Switches on a C200HX/HG/HE(-Z)E Serial Communications Board**

Set the switches on a C200HX/HG/HE(-Z)E Serial Communications Board as follows.

Switch 1: Set to 4 (4-wire, for RS-422A)

Switch 2: Set to ON for terminator ON (terminating resistance applied)

**Setting Switches on a CQM1H Serial Communications Board**

Set the switches on a CQM1H Serial Communications Board as follows.

Wire selection (WIRE): Set to 4 (4-wire, for RS-422A)

Terminator (TERM): Set to ON for termination ON.

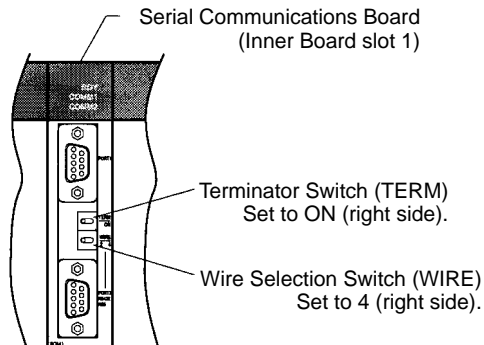

## Using the 1:N NT Link Method

**Compatible Host Units**

The OMRON PCs that can be connected using the RS-422A/485 1:N NT Link are the CS-series (CS1G/H and CS1G/H-H), CJ-series CJ1G, C200HX/HG/HE(-Z)E, and CQM1H models only. A Serial Communications Board/Unit or a Serial Communications Board must be installed to make the connection.

Check the model and series of the PC against the CPU Unit model or Serial Communications Board before making the connections.

The Units that can be connected as hosts to the NT21 by the 1:N NT Link method using a RS-422A/485 port are listed in the following table.

PC Series	CPU Units with Built-in 1:N NT Link Function	CPU Units connectable through a Serial Communications Board	Model
CS Series	---	CS1G-CPU42/43/44/45-E(V1) <sup>(*1)</sup> CS1H-CPU63/64/65/66/67-E(V1) <sup>(*1)</sup> CS1G-CPU42H/43H/44H/45H <sup>(*1)</sup> CS1H-CPU63H/64H/65H/66H/67H <sup>(*1)</sup>	CS1G CS1H CS1G-H CS1H-H
CJ Series	---	CJ1J-CPU44/45 <sup>(*2)</sup>	CJ1G
C Series	---	C200HE-CPU32-(Z)E <sup>(*3)</sup> C200HE-CPU42-(Z)E <sup>(*3)</sup>	C200HE (-Z)E
	---	C200HG-CPU33-(Z)E <sup>(*3)</sup> C200HG-CPU43-(Z)E <sup>(*3)</sup> C200HG-CPU53-(Z)E <sup>(*3)</sup> C200HG-CPU63-(Z)E <sup>(*3)</sup>	C200HG (-Z)E
	---	C200HX-CPU34-(Z)E <sup>(*3)</sup> C200HX-CPU44-(Z)E <sup>(*3)</sup> C200HX-CPU54-(Z)E <sup>(*3)</sup> C200HX-CPU64-(Z)E <sup>(*3)</sup> C200HX-CPU65-ZE <sup>(*3)</sup> C200HX-CPU85-ZE <sup>(*3)</sup>	C200HX (-Z)E
	---	CQM1H-CPU51/61 <sup>(*4)</sup>	CQM1H

\*1 A CS1W-SCB41-E Serial Communications Board is required.

\*2 A CJ1W-SCU41 Serial Communications Unit is required.

\*3 A C200HW-COM03-V1 or C200HW-COM06-V1 Serial Communications Board is required.

\*4 A CQM1H-SCB41 Serial Communications Board is required.

**Settings at the Host****Connecting to a CJ-series Serial Communications Unit****CJ-series: CJ1W-SCU41 (Port 1 is an RS-422A/485 port.)****Setting the Front Switches**

Set the unit number of the Serial Communications Unit with the rotary switch on the front of the Unit. Set the unit number with a flat blade screwdriver. Also, set the communications mode switch to select 2-wire (RS-485) or 4-wire (RS-422A)

communications and set the terminator switch to enable or disable the terminating resistance.

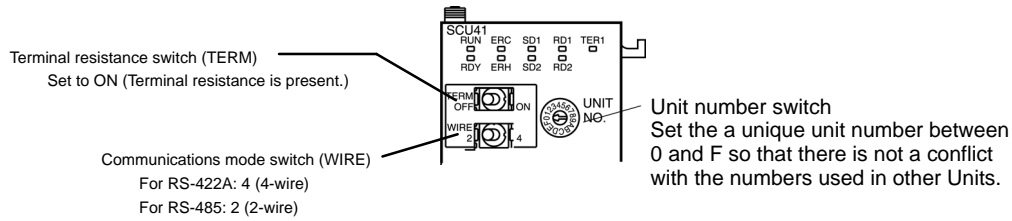

**Allocated DM Area Settings for CPU Unit**

Settings are written from the Programming Device (a Programming Console or CX-Programmer) directly into the allocated DM Area settings (PC Setup) of the CPU Unit. After settings are written, they become effective by turning the power ON, restarting the Unit, restarting the communication port, or executing the STUP instruction.

The following table shows the words allocated in the DM Area and the settings.

Allocated DM word	Writing Value	Settings
Port 1		
DM32000	8200	1:N NT Link mode
DM32001	0000 to 0009 (*1)	Communications baud rate (standard)
DM32006	000□	□ = The largest model number of the connected PTs (0 to 7)

\*1 Set any value between 0000 and 0009 Hex for the communications baud rate. The same baud rate will be used regardless of the value as long as it is between 0000 and 0009 Hex.

For example, when connecting PTs with model numbers 3, 4, 5, and 6 to port 1, set DM 32000 to 8200 Hex, DM 32001 to 0000 Hex, and DM 32006 to 0006 Hex.

**C-series C200HX/HG/HE(-Z)E and CQM1H**

**PC Setup Settings**

Write the communication conditions directly into the PC Setup (data memory) using a Programming Device (e.g., CX-Programmer).

Make the setting indicated in the word shown below.

Host Model	Word	Writing Value	Setting
Port A of a C200HX/HG/HE(-Z)E*1	DM6555	5□00	Use 1:N NT Link □ = largest unit number of the connected PTs (1 to 7)*3
Port 2 of a CQM1H*2	DM6550	5□00	

\*1 The Serial Communications Board's RS-422A/485 port  
 \*2 The Serial Communications Board's RS-422A/485 port  
 \*3 When using C200HE(-Z)E, the maximum PT unit number is 3.

For details on setting the PC Setup settings, refer to the PC's operation manual.

- Reference:**
- There are no Serial Communications Boards for the C200HX/HG/HE(-Z)E in which port B is the RS-422A/485 port.
  - There are no Serial Communications Boards for the CQM1H in which port 1 is the RS-422A/485 port.

**Setting the DIP Switches on a C200HX/HG/HE(-Z)E Serial Communications Board**

Set the switches on a C200HX/HG/HE(-Z)E Serial Communications Board as follows.

Switch 1: Set to 4 (4-wire, for RS-422A), or  
Set to 2 (2-wire, for RS-485)

Switch 2: Set to ON for terminator ON (terminating resistance applied)

**Setting Switches on a CQM1H Serial Communications Board**

Set the switches on a CQM1H Serial Communications Board as follows.

Wire selection (WIRE): Set to 4 (4-wire, for RS-422A)  
or  
Set to 2 (2-wire, for RS-485)

Terminator (TERM): Set to ON for termination ON.

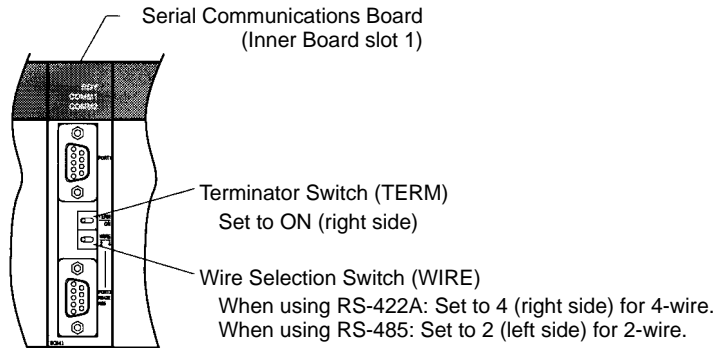

**Connecting to CS-series Serial Communications Board**

Serial Communications Board with RS-422A/485 port equipped for CS-series CPU Unit model:

CS1W-SCB41 (The port 2 is RS-422A/485 port.)

**Setting the Front Switches**

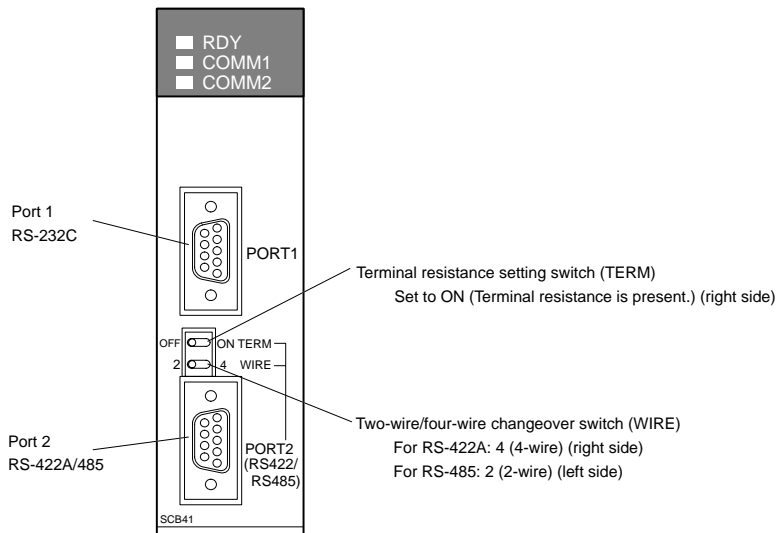

**Allocated DM Area Settings for CPU Unit**

Settings are written from the Programming Device (a Programming Console or CX-Programmer) directly into the allocated DM Area settings (PC Setup) of the CPU Unit. After settings are written, they become effective by turning the power ON, restarting the Unit, restarting the communication port, or executing the STUP instruction.

The following table shows the words allocated in the DM Area and the settings.

Allocated DM word	Value	Settings
Port 2		
DM32010	8200	1:N NT Link mode
DM32011	0000 to 0009 (*1)	Communications baud rate (standard)
DM32016	000□	□ = The largest model number of the connected PTs (0 to 7)

\*1 Set any value between 0000 and 0009 Hex for the communications baud rate. The same baud rate will be used regardless of the value as long as it is between 0000 and 0009 Hex.

For example, when connecting PTs with model numbers 3, 4, 5, and 6 to port 2, set DM 32010 to 8200 Hex, DM 32011 to 0000 Hex, and DM 32016 to 0006 Hex.

**Using the High-speed 1:N NT Link Method**

**Compatible Host Units**

The OMRON PCs that can be connected using the high-speed RS-422A/485 1:N NT Link are the CS-series (CS1G/H and CS1G/H-H), CJ-series CJ1G models only. With the CS-series, a CS1W-SCB41-E Serial Communications Board must be used. With the CJ-series, a CJ1W-SCU41 Serial Communications Unit must be used. (If a Serial Communications Board is used, even CS-series Units without the "-V1" suffix can be connected via high-speed 1:N NT Link.)

Be sure to check the model number of the PC and Board/Unit before trying to establish the high-speed 1:N NT Link.

The following table shows which Units can be connected as hosts to the NT21 with the high-speed 1:N NT Link through the RS-422A/RS-485 port.

PC Series	PCs supporting direct connection to the CPU Unit	PCs supporting connection through a Serial Communications Board/Unit	Connectable models
CS Series	---	CS1G-CPU42/43/44/45-E(V1) (*1) CS1H-CPU63/64/65/66/67-E(V1) (*1) CS1G-CPU42H/43H/44H/45H (*1) CS1H-CPU63H/64H/65H/66H/67H (*1)	CS1G CS1H CS1G-H CS1H-H
CJ Series	---	CJ1G-CPU44/45 (*2)	CJ1G

\*1 A CS1W-SCB41 Serial Communications Board is required.

\*2 A CJ1W-SCU41 Serial Communications Unit is required.

**Settings at the Host**

**Connecting to a CJ-series Serial Communications Unit**

CJ-series: CJ1W-SCU41 (Port 1 is an RS-422A/485 port.)

**Setting the Front Switches**

Set the unit number of the Serial Communications Unit with the rotary switch on the front of the Unit. Set the unit number with a flat blade screwdriver. Also, set the communications mode switch to select 2-wire (RS-485) or 4-wire (RS-422A) communications and set the terminator switch to enable or disable the terminating resistance.

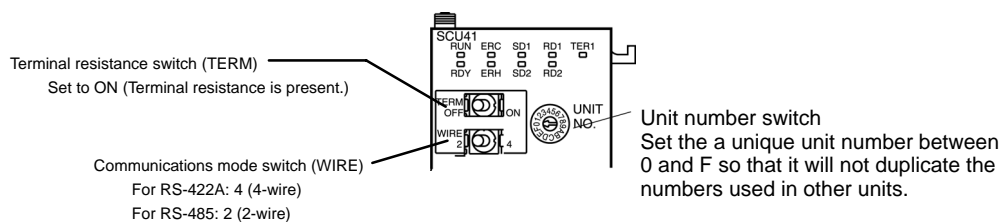

**CPU Unit Allocated DM Area Settings**

Setting is written from the Programming Device (a Programming Console or CX-Programmer) directly into the allocated DM Area settings (PC Setup) of the CPU

Unit. After the settings are written, they become effective by turning the power ON, restarting the Unit, restarting the communication port, or execution of the STUP instruction.

In the following table, the relevant word addresses allocated in the DM Area and settings are shown.

Allocated DM word	Writing Value	Settings
<b>Port 1</b>		
DM32000	8200	1:N NT Link mode
DM32001	000A	Communications baud rate (high-speed)
DM32006	000□	□ = The largest model number of the connected PTs (0 to 7)

For example, when connecting PTs with model numbers 3, 4, 5, and 6 to port 1, set DM 32000 to 8200 Hex, DM 32001 to 000A Hex, and DM 32006 to 0006 Hex.

**Connecting to a CS-series Serial Communications Board**

Serial Communications Board equipped with an RS-422A/485 port for CS-series CPU Units:

CS1W-SCB41 (Port 2 is an RS-422A/485 port.)

**Reference:** Serial Communications Boards and Serial Communications Units with lot number 991220 (12/20/99) and later support the high-speed 1:N NT Link. Boards and Units with earlier lot numbers **cannot** be used.

**Setting the Front Switches**

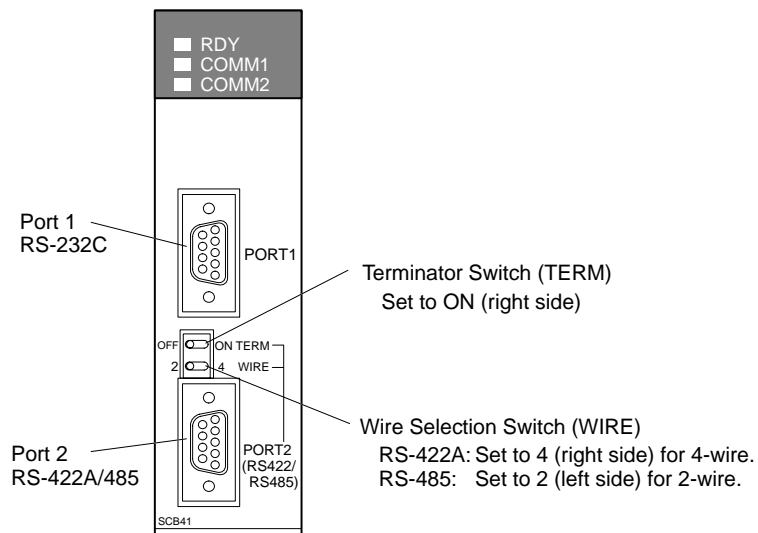

**CPU Unit Allocated DM Area Settings**

Setting is written from the Programming Device (a Programming Console or CX-Programmer) directly into the allocated DM Area settings (PC Setup) of the CPU Unit. After the setting is written, it becomes effective by turning the power ON, restarting the Unit, restarting the communication port, or execution of the STUP instruction.

In the following table, the relevant word addresses allocated in the DM Area and settings are shown.

Allocated DM word	Value	Settings
<b>Port 2</b>		
DM32010	8200	1:N NT Link mode
DM32011	000A	Communications baud rate (high-speed)
DM32016	000□	□ = The largest model number of the connected PTs (0 to 7)

For example, when connecting PTs with model numbers 3, 4, 5, and 6 to port 2, set DM 32010 to 8200 Hex, DM 32011 to 000A Hex, and DM 32016 to 0006 Hex.

**When using the Memory Link Method**

With the memory link method, the connection can be made to a personal computer or FA computer equipped with RS-422A.

When connecting to the host with the memory link method, it is necessary to create a program for the memory link at the host.

The communication conditions that can be used with the memory link method are listed in the following table. For the host (a personal computer, an FA computer, etc.), its setting should be compatible to one of the communication conditions listed in the following table. Set the same communication conditions at the NT21 by the memory switch. (page 132).

Item	Setting at Host
I/O port	RS-422A
Baud rate	1,200, 2,400, 4,800, 9,600, 19,200, or 38,400 bps.
Data bits	7 bits, 8 bits
Stop bits	1 bit, 2 bits
Parity	None, even, odd
Flow control	None, XON/XOFF

**5-1-2 Direct 1:1 Connection to the Host's RS-422A**

This section explains how to connect the NT21's RS-232C port with the host's RS-422A port through a Link Adapter.

A Link Adapter (NT-AL001 or NS-AL002) is required to convert communications methods between the RS-232C and RS-422A formats.

**Connecting the NT21 to the Link Adapter (RS-232C)**

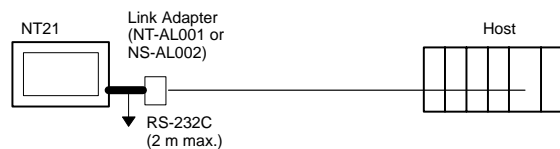

**Compatible Cables with Attached Connectors:**

- XW2Z-070T-1 (9-pin to 9-pin, 0.7 m)
- XW2Z-200T-1 (9-pin to 9-pin, 2 m)

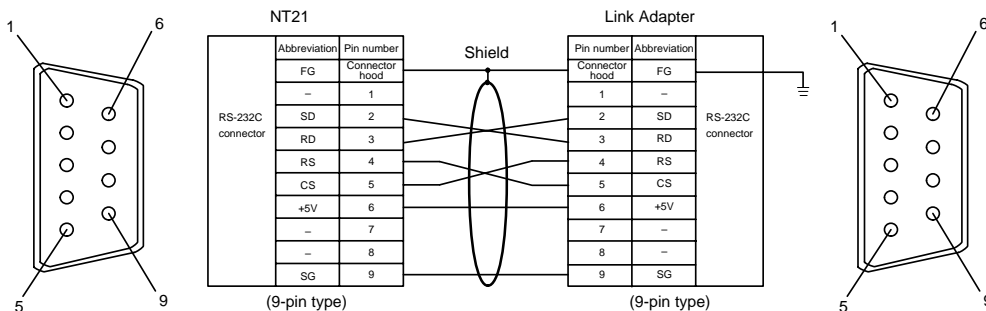





To avoid an FG ground loop, do not connect the functional ground of the Link Adapter to the shielding of the RS-422A cable.

**Wiring to one of the following Serial Communications Boards/Units**

- CS-series CS1G/H(-H) Serial Communications Board
- CJ-series CJ1G Serial Communications Unit
- C-series C200HX/HG/HE(-Z)E Serial Communications Board
- CQM1H Serial Communications Board
- CVM1/CV-series Host Link Unit

Applicable Units:

- |                                    |                   |
|------------------------------------|-------------------|
| CS1G-CPU42-E(V1)                   | CS1G-CPU43-E(V1)  |
| CS1G-CPU44-E(V1)                   | CS1G-CPU45-E(V1)  |
| CS1H-CPU63-E(V1)                   | CS1H-CPU64-E(V1)  |
| CS1H-CPU65-E(V1)                   | CS1H-CPU66-E(V1)  |
| CS1H-CPU67-E(V1)                   |                   |
| CS1G-CPU42H                        | CS1G-CPU43H       |
| CS1G-CPU44H                        | CS1G-CPU45H       |
| CS1H-CPU63H                        | CS1H-CPU64H       |
| CS1H-CPU65H                        | CS1H-CPU66H       |
| CS1H-CPU67H                        |                   |
| CJ1W-SCU41 (communication port 1)  |                   |
| C200HE-CPU32-(Z)E                  | C200HE-CPU42-(Z)E |
| C200HG-CPU33-(Z)E                  | C200HG-CPU43-(Z)E |
| C200HG-CPU53-(Z)E                  | C200HG-CPU63-(Z)E |
| C200HX-CPU34-(Z)E                  | C200HX-CPU44-(Z)E |
| C200HX-CPU54-(Z)E                  | C200HX-CPU64-(Z)E |
| C200HX-CPU65-ZE                    | C200HX-CPU85-ZE   |
| CQM1H-CPU51                        | CQM1H-CPU61       |
| CV500-LK201 (communication port 2) |                   |

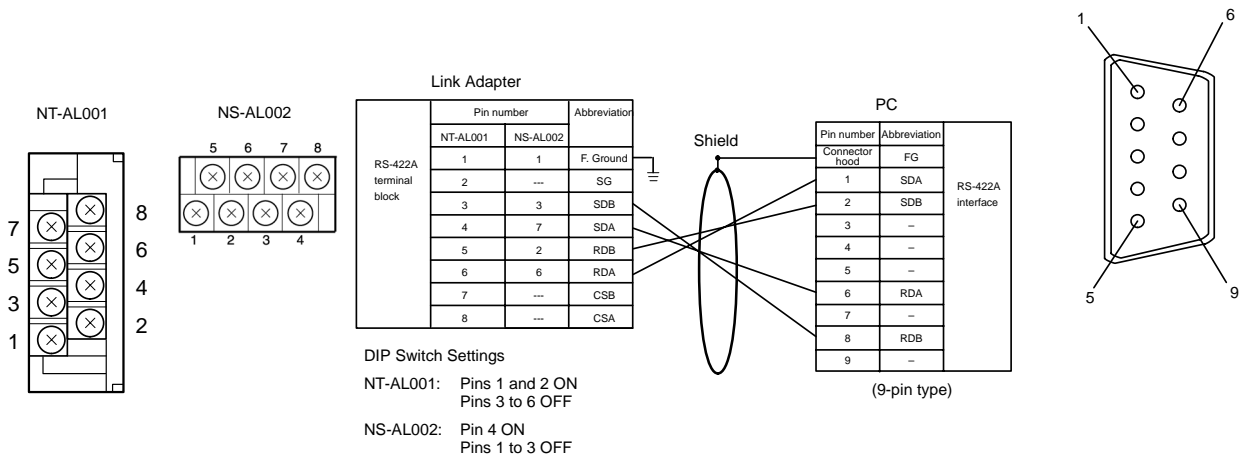

To avoid an FG ground loop, do not connect the functional ground of the Link Adapter to the shielding of the RS-422A cable.

**Wiring to a CVM1/CV-series CPU Unit**

Applicable Units:

- |                |                |
|----------------|----------------|
| CVM1-CPU01-EV□ | CVM1-CPU11-EV□ |
| CVM1-CPU21-EV□ |                |

CVM1/CV-series CPU Units whose model names do not have the suffix -EV□ cannot be connected by any connection method.

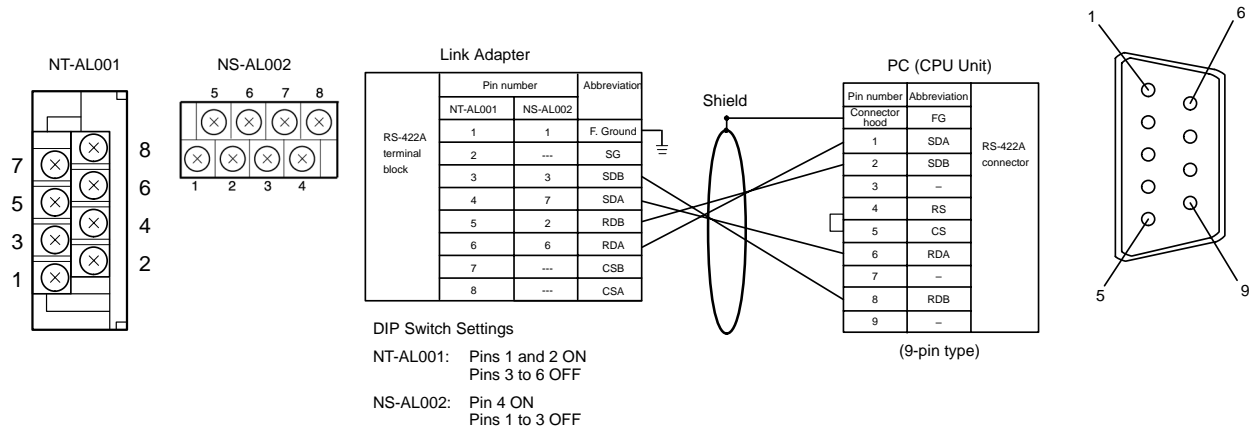

To avoid an FG ground loop, do not connect the functional ground of the Link Adapter to the shielding of the RS-422A cable.

**Wiring a Memory Link Connection**

Prepare the adapter cable while referring to the following diagram.

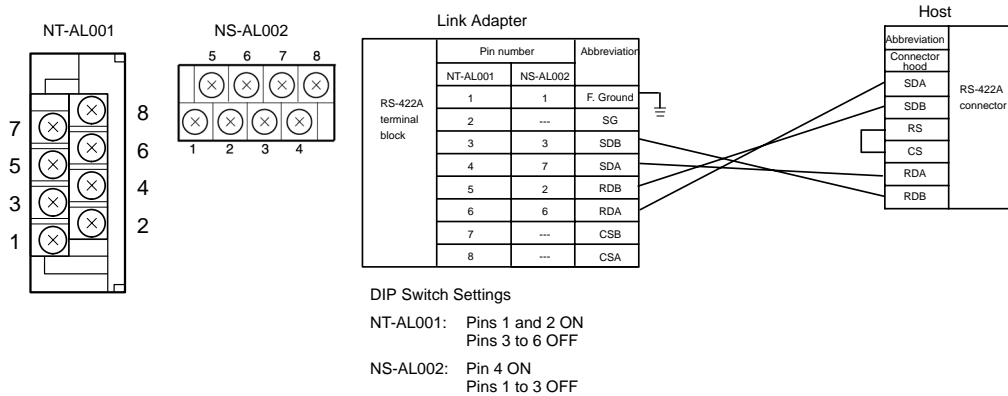

To avoid an FG ground loop, do not connect the functional ground of the Link Adapter to the shielding of the RS-422A cable.

**5-1-3 Direct 1:1 Connection to the Host's RS-485**

This section explains how to connect the NT21's RS-232C port with the host's RS-485 port through a Link Adapter.

A Link Adapter (NT-AL001 or NS-AL002) is required to convert communications methods between the RS-232C and RS-485 formats.

**Reference:** RS-485 can be used between the Link Adapter and host only when the 1:N NT Link method (standard or high-speed) is selected at the host.

**Connecting the NT21 to the Link Adapter (RS-232C)**

The RS-232C connection between the NT21 and Link Adapter is the same whether RS-422A or RS-485 communications are used between the Link Adapter and host. Refer to *Connecting the NT21 to the Link Adapter (RS-232C)* on page 85 for details on the RS-232C connection.

**Connecting the Link Adapter to the Host (RS-485)**

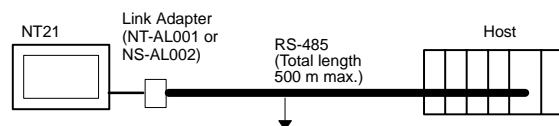

**Wiring to one of the following Serial Communications Boards/Units**

- CS-series CS1G/H(-H) Serial Communications Board
- CJ-series CJ1G Serial Communications Unit
- C-series C200HX/HG/HE(-Z)E Serial Communications Board
- CQM1H Serial Communications Board

Applicable Units:

- |                                   |                   |
|-----------------------------------|-------------------|
| CS1G-CPU42-E(V1)                  | CS1G-CPU43-E(V1)  |
| CS1G-CPU44-E(V1)                  | CS1G-CPU45-E(V1)  |
| CS1H-CPU63-E(V1)                  | CS1H-CPU64-E(V1)  |
| CS1H-CPU65-E(V1)                  | CS1H-CPU66-E(V1)  |
| CS1H-CPU67-E(V1)                  |                   |
| CS1G-CPU42H                       | CS1G-CPU43H       |
| CS1G-CPU44H                       | CS1G-CPU45H       |
| CS1H-CPU63H                       | CS1H-CPU64H       |
| CS1H-CPU65H                       | CS1H-CPU66H       |
| CS1H-CPU67H                       |                   |
| CJ1W-SCU41 (communication port 1) |                   |
| C200HE-CPU32-(Z)E                 | C200HE-CPU42-(Z)E |
| C200HG-CPU33-(Z)E                 | C200HG-CPU43-(Z)E |
| C200HG-CPU53-(Z)E                 | C200HG-CPU63-(Z)E |
| C200HX-CPU34-(Z)E                 | C200HX-CPU44-(Z)E |
| C200HX-CPU54-(Z)E                 | C200HX-CPU64-(Z)E |
| C200HX-CPU65-ZE                   | C200HX-CPU85-ZE   |
| CQM1H-CPU51                       | CQM1H-CPU61       |

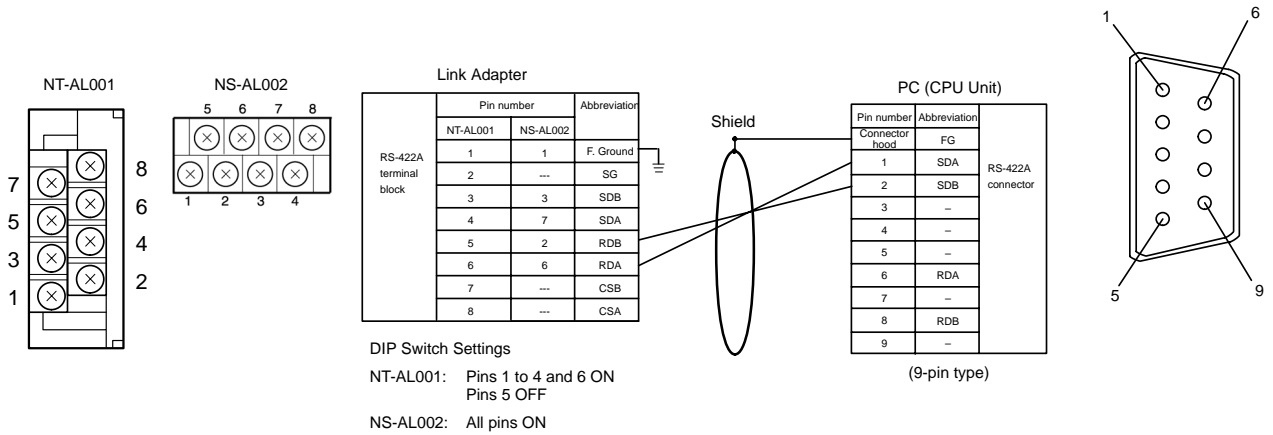

To avoid an FG ground loop, do not connect the functional ground of the Link Adapter to the shielding of the RS-485 cable.

**5-1-4 1:N Connection to the Host's RS-422A Port**

This section explains how to connect the RS-232C ports of two or more NT21s with the host's RS-485 port through Link Adapters.

Link Adapters (NT-AL001 or NS-AL002) are required to convert communications methods between the RS-232C and RS-422A formats.

- Reference:**
- The RS-422A **standard** 1:N NT link method can be used only when the following Boards/Units are installed:
    - CS1W-SCB41 Serial Communications Board in a CS-series CS1G/H(-H)
    - CJ1W-SCU41 Serial Communications Unit in a CJ-series CJ1G Serial Communications Board in a C200HX/HG/HE(-Z)E
    - CQM1H-SCB41 Serial Communications Board in a CQM1H
  - The RS-422A **high-speed** 1:N NT link method can be used only when the following Boards/Units are installed:
    - CS1W-SCB41 Serial Communications Board in a CS-series CS1G/H(-H)
    - CJ1W-SCU41 Serial Communications Unit in a CJ-series CJ1G

**Connecting the NT21s to the Link Adapters (RS-232C)**

The RS-232C connections between the NT21s and Link Adapters in a 1:N configuration are the same as the connection in a 1:1 configuration. Refer to *Connecting the NT21 to the Link Adapter (RS-232C)* on page 85 for details on the RS-232C connections.

**Connecting the Link Adapters between NT21s (RS-422A)**

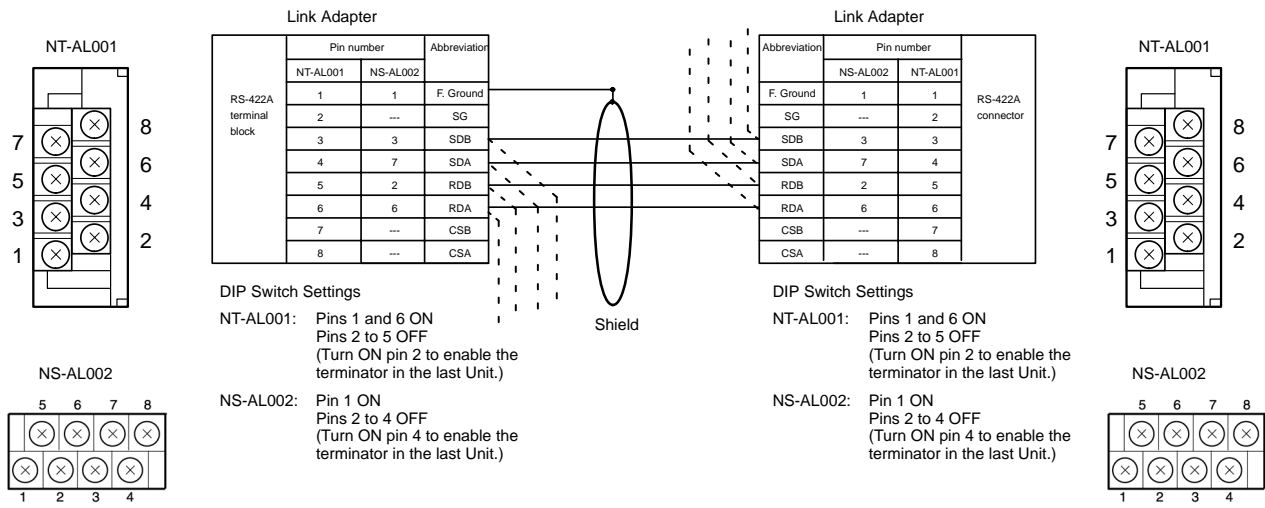
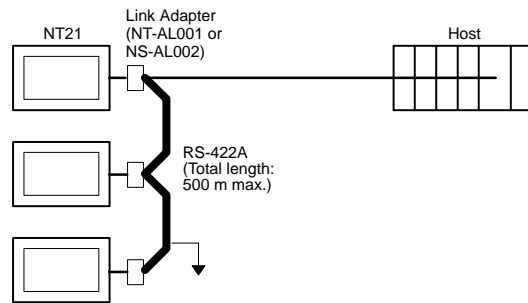

To avoid an FG ground loop, do not connect the functional ground of only one of the Link Adapters to the shielding of the RS-422A cable.

Connecting the Link Adapters to the Host (RS-422A)

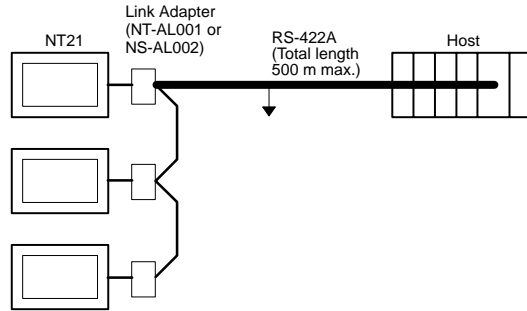

**Wiring to one of the following Serial Communications Boards/Units**

- CS-series CS1G/H(-H) Serial Communications Board
- CJ-series CJ1G Serial Communications Unit
- C-series C200HX/HG/HE(-Z)E Serial Communications Board
- CQM1H Serial Communications Board

Applicable Units:

- |                                   |                   |
|-----------------------------------|-------------------|
| CS1G-CPU42-E(V1)                  | CS1G-CPU43-E(V1)  |
| CS1G-CPU44-E(V1)                  | CS1G-CPU45-E(V1)  |
| CS1H-CPU63-E(V1)                  | CS1H-CPU64-E(V1)  |
| CS1H-CPU65-E(V1)                  | CS1H-CPU66-E(V1)  |
| CS1H-CPU67-E(V1)                  |                   |
| CS1G-CPU42H                       | CS1G-CPU43H       |
| CS1G-CPU44H                       | CS1G-CPU45H       |
| CS1H-CPU63H                       | CS1H-CPU64H       |
| CS1H-CPU65H                       | CS1H-CPU66H       |
| CS1H-CPU67H                       |                   |
| CJ1W-SCU41 (communication port 1) |                   |
| C200HE-CPU32-(Z)E                 | C200HE-CPU42-(Z)E |
| C200HG-CPU33-(Z)E                 | C200HG-CPU43-(Z)E |
| C200HG-CPU53-(Z)E                 | C200HG-CPU63-(Z)E |
| C200HX-CPU34-(Z)E                 | C200HX-CPU44-(Z)E |
| C200HX-CPU54-(Z)E                 | C200HX-CPU64-(Z)E |
| C200HX-CPU65-ZE                   | C200HX-CPU85-ZE   |
| CQM1H-CPU51                       | CQM1H-CPU61       |

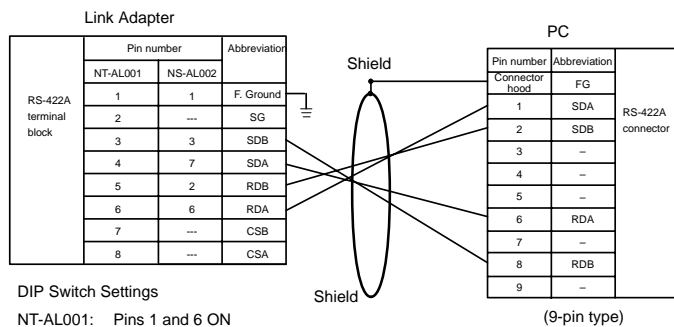
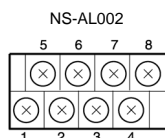
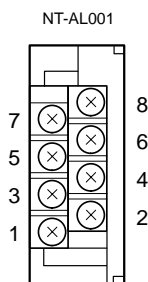

DIP Switch Settings  
 NT-AL001: Pins 1 and 6 ON  
 Pins 2 to 5 OFF  
 NS-AL002: Pin 1 ON  
 Pins 2 to 4 OFF

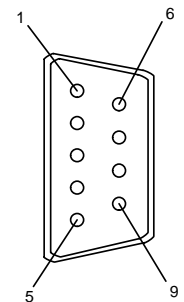

To avoid an FG ground loop, do not connect the functional ground of the Link Adapter to the shielding of the RS-422A cable.

### 5-1-5 1:N Connection to the Host's RS-485 Port

This section explains how to connect the RS-232C ports of two or more NT21s with the host's RS-485 port through Link Adapters.

NS-AL002 Link Adapters are required to convert communications methods between the RS-232C and RS-485 formats.

- Reference:**
- The RS-485 **standard** 1:N NT link method can be used only when the following Boards/Units are installed:
    - CS1W-SCB41 Serial Communications Board in a CS-series CS1G/H(-H)
    - CJ1W-SCU41 Serial Communications Unit in a CJ-series CJ1G Serial Communications Board in a C200HX/HG/HE(-Z)E
    - CQM1H-SCB41 Serial Communications Board in a CQM1H
  - The RS-485 **high-speed** 1:N NT link method can be used only when the following Boards/Units are installed:
    - CS1W-SCB41 Serial Communications Board in a CS-series CS1G/H(-H)
    - CJ1W-SCU41 Serial Communications Unit in a CJ-series CJ1G

#### Connecting the NT21s to the Link Adapters (RS-232C)

The RS-232C connections between the NT21s and Link Adapters in a 1:N configuration is the same as the connection in a 1:1 RS-422A configuration. Refer to *Connecting the NT21 to the Link Adapter (RS-232C)* on page 85 for details on the RS-232C connections.

#### Connecting the Link Adapters between NT21s (RS-485)

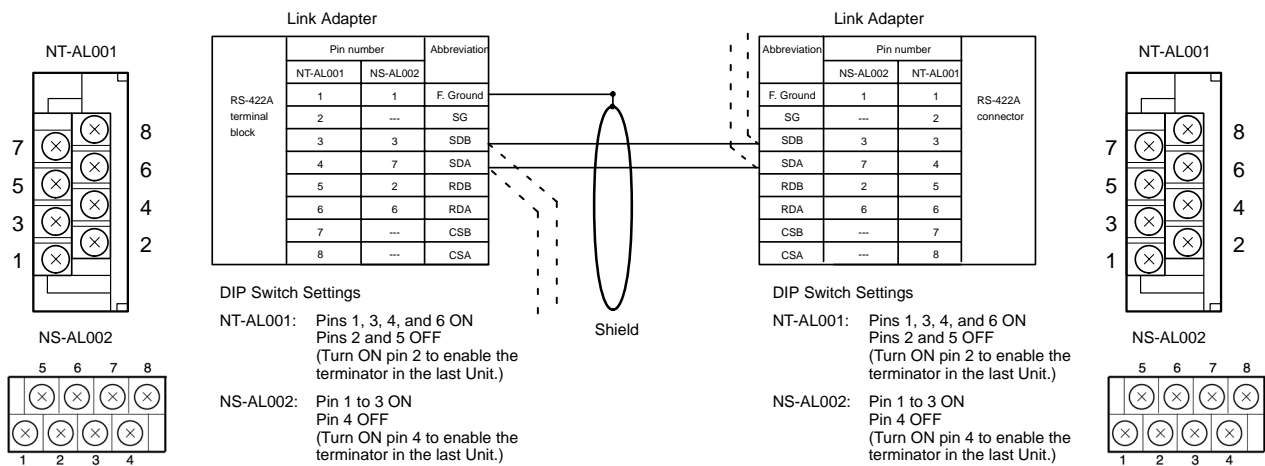
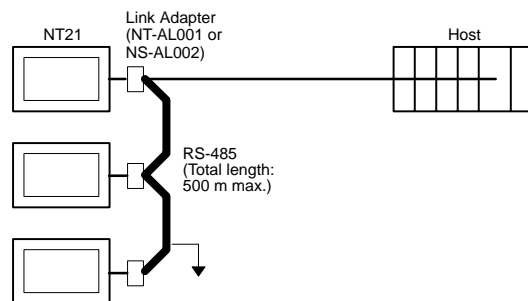

To avoid an FG ground loop, connect the functional ground of only one of the Link Adapters to the shielding of the RS-485 cable.

Connecting the Link Adapter to the Host (RS-485)

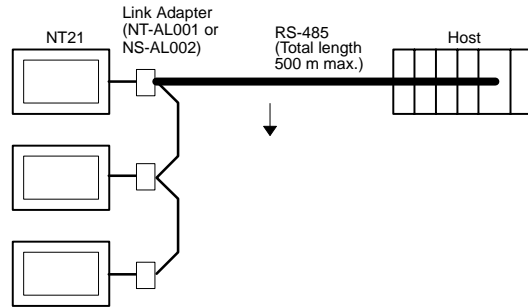

**Wiring to one of the following Serial Communications Boards/Units**

- CS-series CS1G/H(-H) Serial Communications Board
- CJ-series CJ1G Serial Communications Unit
- C-series C200HX/HG/HE(-Z)E Serial Communications Board
- CQM1H Serial Communications Board

Applicable Units:

- |                                   |                   |
|-----------------------------------|-------------------|
| CS1G-CPU42-E(V1)                  | CS1G-CPU43-E(V1)  |
| CS1G-CPU44-E(V1)                  | CS1G-CPU45-E(V1)  |
| CS1H-CPU63-E(V1)                  | CS1H-CPU64-E(V1)  |
| CS1H-CPU65-E(V1)                  | CS1H-CPU66-E(V1)  |
| CS1H-CPU67-E(V1)                  |                   |
| CS1G-CPU42H                       | CS1G-CPU43H       |
| CS1G-CPU44H                       | CS1G-CPU45H       |
| CS1H-CPU63H                       | CS1H-CPU64H       |
| CS1H-CPU65H                       | CS1H-CPU66H       |
| CS1H-CPU67H                       |                   |
| CJ1W-SCU41 (communication port 1) |                   |
| C200HE-CPU32-(Z)E                 | C200HE-CPU42-(Z)E |
| C200HG-CPU33-(Z)E                 | C200HG-CPU43-(Z)E |
| C200HG-CPU53-(Z)E                 | C200HG-CPU63-(Z)E |
| C200HX-CPU34-(Z)E                 | C200HX-CPU44-(Z)E |
| C200HX-CPU54-(Z)E                 | C200HX-CPU64-(Z)E |
| C200HX-CPU65-ZE                   | C200HX-CPU85-ZE   |
| CQM1H-CPU51                       | CQM1H-CPU61       |

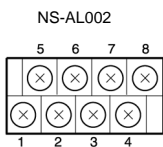
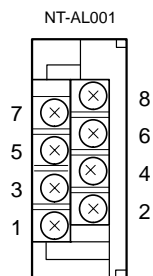

RS-422A terminal block	Pin number		Abbreviation
	NT-AL001	NS-AL002	
1	1	F. Ground	
2	---	SG	
3	3	SDB	
4	7	SDA	
5	2	RDB	
6	6	RDA	
7	---	CSB	
8	---	CSA	

DIP Switch Settings

NT-AL001: Pins 1, 3, 4, and 6 ON  
Pins 2 and 5 OFF

NS-AL002: Pin 1 to 3 ON  
Pin 4 OFF

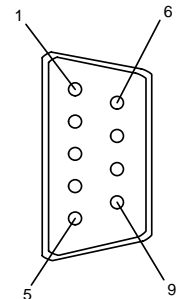
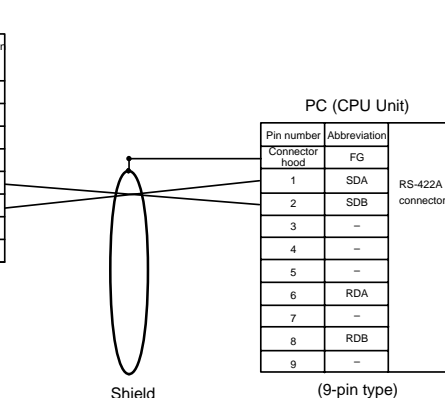



To avoid an FG ground loop, do not connect the functional ground of the Link Adapters to the shielding of the RS-485 cable.

### 5-1-6 Recommended Connectors, Cables and Crimp Terminals

#### Connectors and Cables Recommended for RS-422A/485

When making an RS-422A/485 connecting cable, as far as possible use the recommended parts indicated in the table below. When using the memory link method, however, use a connector that matches with the RS-422A port at the CPU Unit (PC). Some Units come supplied with one connector and connector hood.

Check the required parts and prepare them in advance.

Name	Model	Maker	Remarks
Connector set	XM2S-0911-S003	OMRON	9-pin connector Connector and Connector hood
Connector	XM2A-0901	9-pin connector Made by OMRON	
Connector hood	XM2S-0911	9-pin connector Made by OMRON	
Cable	TKVVBS4P-03	Tachii Electric Wire Co., Ltd.	
Crimp terminals	1.25-N3A (fork type)	Japan Solderless Terminal MFG	Recommended cable size: AWG22 to 18 (0.3 to 0.75 mm <sup>2</sup> )
	Y1.25-3.5L (fork type)	Molex Inc.	

- Note**
1. Always use crimp terminals for wiring.
  2. Before connecting or disconnecting cables between devices, make sure that the power supply to all of the connected devices (NT21, PC, etc.) is OFF.

Examples of applicable terminals

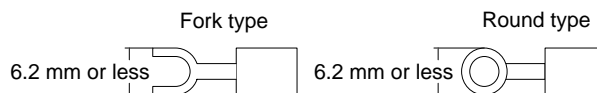

## 5-2 Connecting to the Host's RS-232C Port

This section explains how to connect to the host's RS-232C port through an RS-422A/485 cable. This explanation focuses on connections to OMRON PCs, although any RS-232C device can be connected using the memory link method.

The following diagram shows a 1:N connection between the RS-232C ports on several PTs and the RS-232C port on the host through Link Adapters and RS-422A or RS-485 cable. This connection method can only be used with the 1:N NT Link (standard or high-speed).

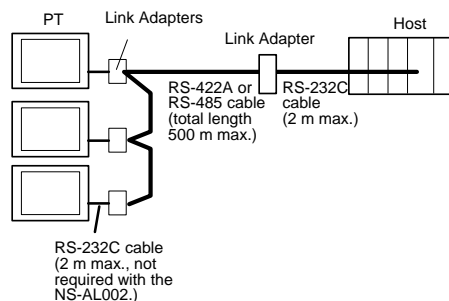

**Note** One end of the wire must always be connected to the host (PC), and there must be no branching. Branching will cause problems such as transmission delays and communications failures.

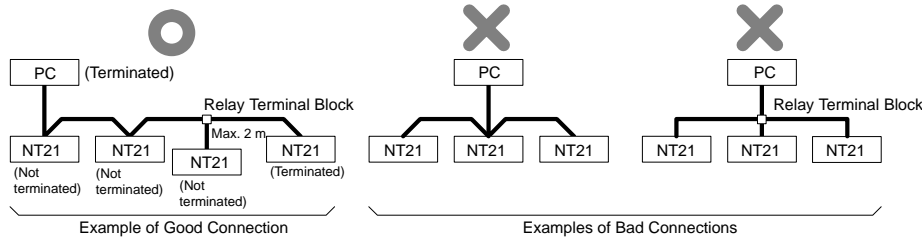

**Reference:** CS/CJ-series CPU Units cannot be connected with the 1:1 connection NT link method. Use the 1:N connection NT Link method (standard or high-speed) instead of making the 1:1 connection. For details, refer to *Using the 1:N NT Link method* (page 55) or *Using the High-speed 1:N NT Link method* (page 60).

### 5-2-1 Host Types and Settings

The usage conditions are the same as they are when both the PT and host are connected through their RS-232C ports.

Refer to the pages listed below for details on the various connection methods, the hosts that can be connected with each method, and the required host settings.

Method	Reference
Host Link	Using the Host Link Method (page 40)
1:1 NT link	Using the 1:1 NT Link method (page 51)
1:N NT link	Using the 1:N NT Link Method (page 55)
High-speed 1:N NT link	Using the High-speed 1:N NT Link Method (page 60)
Memory link	Memory Link Method (page 63)

### 5-2-2 1:N Connection Using the Host's RS-232C Port

This section explains how to connect several NT21 PTs through their RS-232C ports to a single host through its RS-232C port using Link Adapters and RS-422A/485 cable. Link Adapters (NT-AL001 or NS-AL002) are required to convert communication methods between the RS-232C and RS-422A/485 formats.

The following diagram shows a 1:N connection between the RS-232C ports on several PTs and the RS-232C port on the host through Link Adapters and RS-422A or RS-485 cable. NT-AL001, NS-AL002 Link Adapters are required to convert communication methods between RS-232C and RS-422A/485.

#### Connecting the NT21s to the Link Adapters (RS-232C)

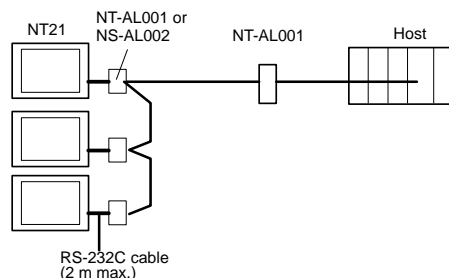

**Compatible Cables with Attached Connectors:**

- XW2Z-070T-1 (9-pin to 9-pin, 0.7 m)
- XW2Z-200T-1 (9-pin to 9-pin, 2 m)

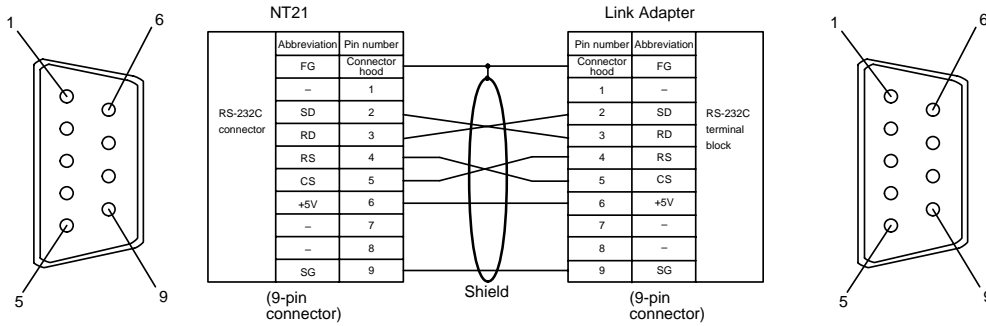

When an NT-AL001 Link Adapter is being used, the RS-232C cable can be connected to either serial port A or B on the NT21.

When an NS-AL002 Link Adapter is being used, the Link Adapter connects directly to serial port B on the NT21, so an RS-232C cable is not required.

**Connecting the NT21-side Link Adapters to the Host-side Link Adapter (RS-422A)**

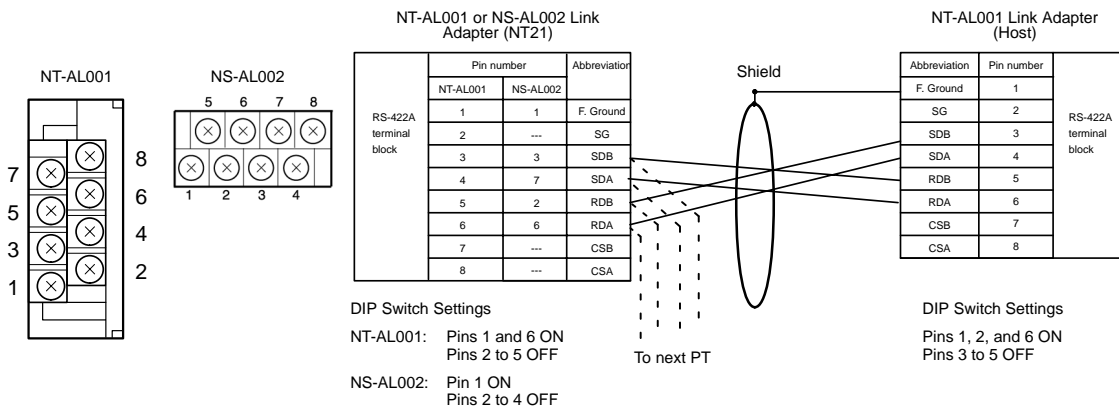
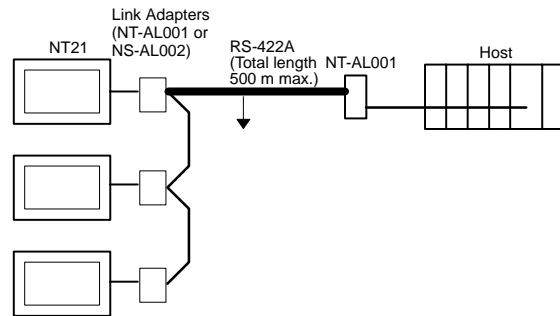

To avoid an FG ground loop, do not connect the functional ground of the Link Adapter at the NT21 to the RS-422A cable shielding.

Connecting the NT21-side Link Adapters to the Host-side Link Adapter (RS-485)

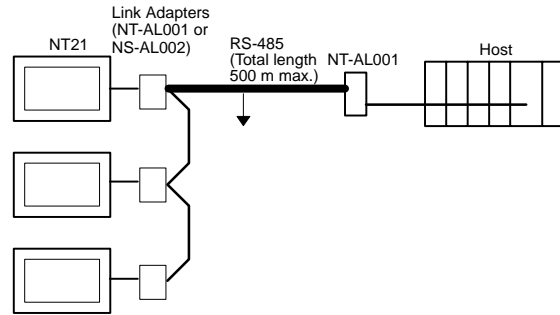

NT-AL001

NS-AL002

RS-422A terminal block	Pin number		Abbreviation
	NT-AL001	NS-AL002	
1	1	1	F. Ground
2	---	---	SG
3	3	3	SDB
4	7	7	SDA
5	2	2	RDB
6	6	6	RDA
7	---	---	CSB
8	---	---	CSA

NT-AL001 Link Adapter (Host)

Abbreviation	Pin number
F. Ground	1
SG	2
SDB	3
SDA	4
RDB	5
RDA	6
CSB	7
CSA	8

DIP Switch Settings  
Pins 1 to 4 and 6 ON  
Pin 5 OFF

Shield

To next PT

To avoid an FG ground loop, do not connect the functional ground of the Link Adapter at the NT21 to the RS-485 cable shielding.

Connecting between the NT21-side Link Adapters (RS-422A)

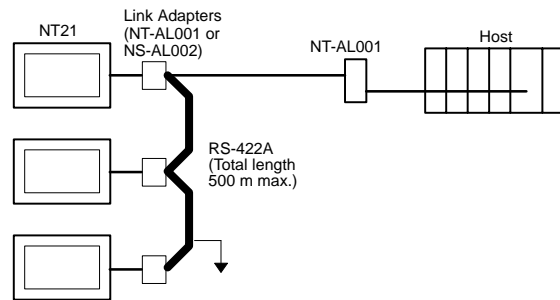

NT-AL001

Link Adapter

RS-422A terminal block	Pin number		Abbreviation
	NT-AL001	NS-AL002	
1	1	1	F. Ground
2	---	---	SG
3	3	3	SDB
4	7	7	SDA
5	2	2	RDB
6	6	6	RDA
7	---	---	CSB
8	---	---	CSA

DIP Switch Settings  
NT-AL001: Pins 1 and 6 ON  
Pins 2 to 5 OFF  
(Turn ON pin 2 to enable the terminator in the last Unit.)  
NS-AL002: Pin 1 ON  
Pins 2 to 4 OFF  
(Turn ON pin 4 to enable the terminator in the last Unit.)

Link Adapter

RS-422A terminal block	Pin number		Abbreviation
	NS-AL002	NT-AL001	
F. Ground	1	1	F. Ground
SG	---	---	SG
SDB	3	3	SDB
SDA	7	7	SDA
RDB	2	2	RDB
RDA	6	6	RDA
CSB	---	---	CSB
CSA	---	---	CSA

DIP Switch Settings  
NT-AL001: Pins 1 and 6 ON  
Pins 2 to 5 OFF  
(Turn ON pin 2 to enable the terminator in the last Unit.)  
NS-AL002: Pin 1 ON  
Pins 2 to 4 OFF  
(Turn ON pin 4 to enable the terminator in the last Unit.)

NT-AL001

NS-AL002

Shield

NS-AL002

To avoid an FG ground loop, connect the functional ground of only one of the Link Adapters at the NT21 to the RS-422A cable shielding.

**Connecting between the NT21-side Link Adapters (RS-485)**

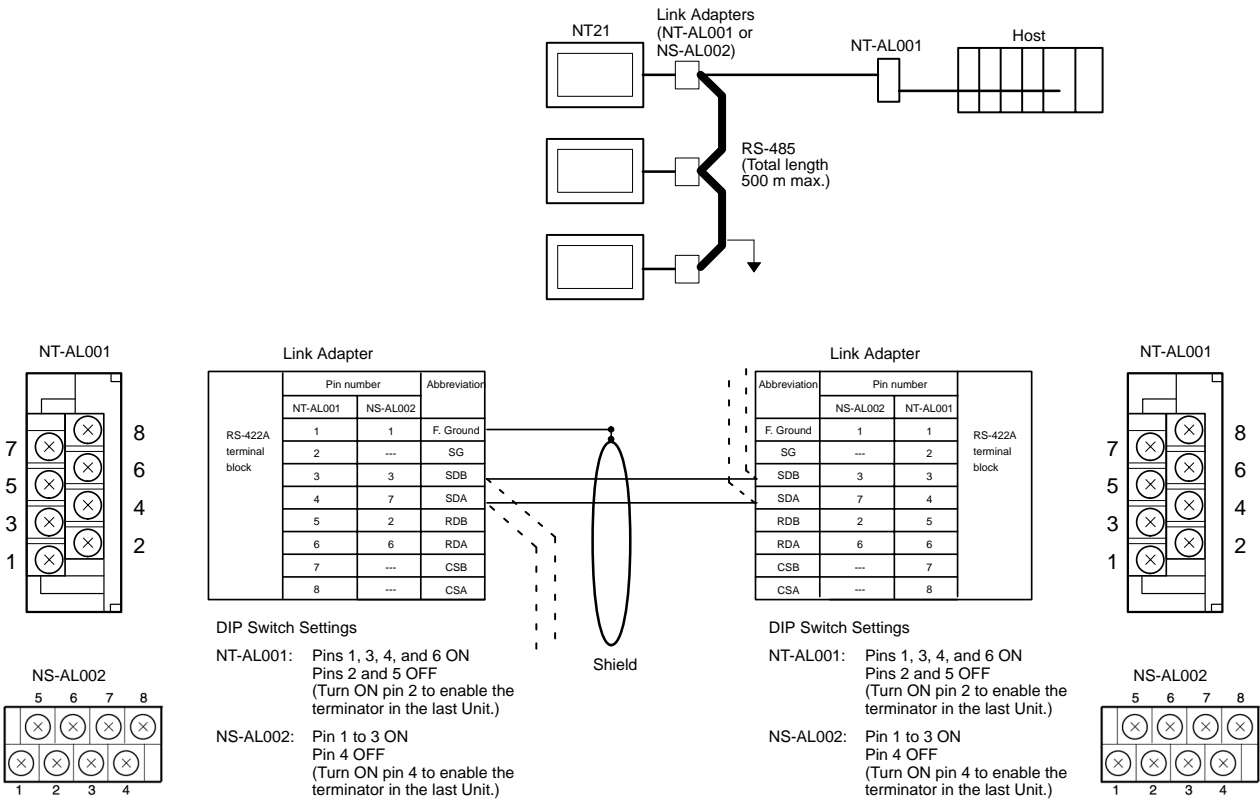

To avoid an FG ground loop, connect the functional ground of only one of the Link Adapters at the NT21 to the RS-485 cable shielding.

**Connecting the Host-side NT-AL001 Link Adapter to the Host (RS-232C)**

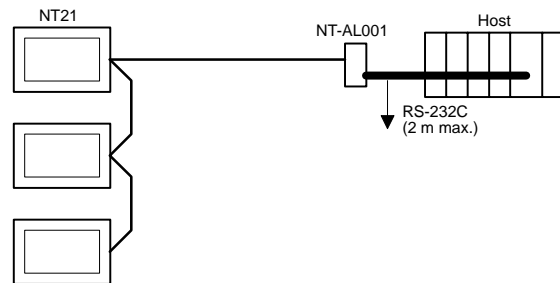

**Wiring to one of the following Serial Communications Boards/Units**

- CS-series CS1G/H(-H) Serial Communications Board
- CJ-series CJ1G Serial Communications Unit
- CQM1H Serial Communications Board
- C-series C200HX/HG/HE(-Z)E Serial Communications Board

Applicable CPU Units:

- |                  |                  |
|------------------|------------------|
| CS1G-CPU42-E(V1) | CS1G-CPU43-E(V1) |
| CS1G-CPU44-E(V1) | CS1G-CPU45-E(V1) |
| CS1H-CPU63-E(V1) | CS1H-CPU64-E(V1) |
| CS1H-CPU65-E(V1) | CS1H-CPU66-E(V1) |
| CS1H-CPU67-E(V1) |                  |
| CS1G-CPU42H      | CS1G-CPU43H      |

CS1G-CPU44H	CS1G-CPU45H
CS1H-CPU63H	CS1H-CPU64H
CS1H-CPU65H	CS1H-CPU66H
CS1H-CPU67H	
CJ1G-CPU44	CJ1G-CPU45
CQM1H-CPU51	CQM1H-CPU61
C200HE-CPU32-(Z)E	C200HE-CPU42-(Z)E
C200HG-CPU33-(Z)E	C200HG-CPU43-(Z)E
C200HG-CPU53-(Z)E	C200HG-CPU63-(Z)E
C200HX-CPU34-(Z)E	C200HX-CPU44-(Z)E
C200HX-CPU54-(Z)E	C200HX-CPU64-(Z)E
C200HX-CPU65-ZE	C200HX-CPU85-ZE

Usable Cables with Attached Connectors:

- For Host Link, 1:1 NT Link, or 1:N NT Link (+5 V power supplied from PC)
  - XW2Z-070T-1 (9-pin to 9-pin, 0.7 m)
  - XW2Z-200T-1 (9-pin to 9-pin, 2 m)
  - SJ46006-102 (9-pin to 9-pin, 1 m)
  - SJ46006-202 (9-pin to 9-pin, 2 m)

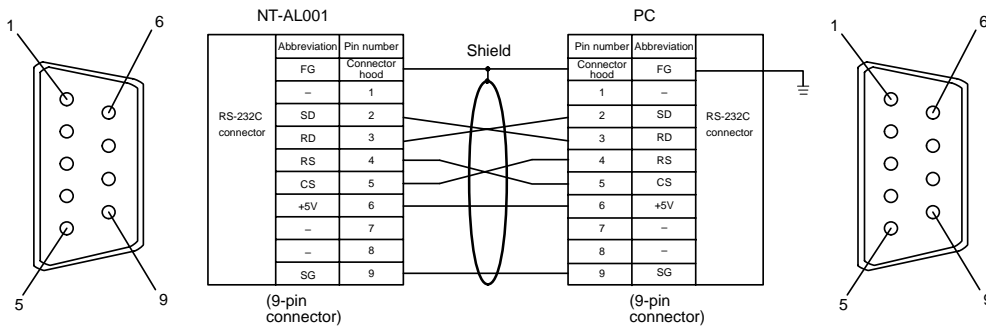

Since the CS1G/H(-H), CJ1G, CQM1H, and C200HX/HG/HE(-Z)E have a +5 V output, no external power supply is required for the NT-AL001.

### 5-2-3 Recommended Connectors, Cables, and Crimp Terminals

#### Connectors and Cables Recommended for RS-232C

When making an RS-232C connecting cable, as far as possible use the recommended parts indicated in the table below. Some Units come supplied with one connector and connector hood.

Check the required parts and prepare them in advance.

Name	Model	Maker	Delivered with
Connector set	XM2S-0911-S003	OMRON	9-pin connector Connector and Connector hood
Connector	XM2A-0901	9-pin connector Made by OMRON	
Connector hood	XM2S-0911	9-pin connector Made by OMRON	
Cable	AWG28 × 5P IFVV-SB	Multi-core shielded cable Made by Fujikura, Ltd.	---
	CO-MA-VV-SB 5P × 28AWG	Multi-core shielded cable Made by Hitachi, Ltd.	---

**Cables with Connectors Made by OMRON**

When connecting an NT-AL001 and a PC, use the OMRON cables with connectors indicated in the table below.

Model	Cable Length	Connector Specification
XW2Z-200S	2 m	9-pin ↔ 25-pin Host Link, 1:1 NT Link
XW2Z-200T	2 m	9-pin ↔ 9-pin Host Link, 1:1 NT Link
SJ45007-102	1 m	9-pin ↔ 9-pin Host Link, 1:1 NT Link
SJ45007-202	2 m	+5 V power supply wire attached (Use when the PC does not have a +5 V output.)
XW2Z-070T-1	0.7 m	9-pin ↔ 9-pin Host Link, 1:1 NT Link, 1:N NT Link
XW2Z-200T-1	2 m	+5 V power supplied from PC (Use when the PC has a +5 V output.)
SJ46006-102	1 m	9-pin ↔ 9-pin Host Link, 1:1 NT Link, 1:N NT Link
SJ46006-202	2 m	+5 V power supplied from PC (Use when the PC has a +5 V output.)

- Note**
1. The maximum tensile load of the recommended cable is 30 N. Do not exceed this load.
  2. After connecting a connecting cable, always tighten the connector screws.

# SECTION 6

## System Menu Operation

This section describes the operation of the System Menu, focusing on the procedure to start the PT. Functions that are convenient when using the PT and those that are useful for system maintenance are also explained here.

6-1	System Menu Operation Flow .....	103
6-2	Starting the NT21 .....	104
6-2-1	Operation at Startup .....	104
6-3	Operation Modes and the System Menu .....	105
6-3-1	Relationships among Modes .....	105
6-3-2	Menu Tree .....	107
6-3-3	Operations with the System Menu .....	108
6-4	Memory Initialization .....	110
6-4-1	Clearing Screen Data .....	110
6-4-2	Initializing Display History Record Data .....	112
6-4-3	Initializing Alarm History Record Data .....	113
6-4-4	Initializing the Memory Tables .....	114
6-4-5	Initializing the Memory Switches .....	116
6-4-6	Initializing the Recipe Tables .....	117
6-5	Operations in the System Installer Mode .....	118
6-5-1	Calling the System Installer Mode .....	118
6-5-2	Clearing/Installing the System Program .....	119
6-5-3	Changing the System Settings .....	120
6-5-4	Clearing Screen Data .....	121
6-6	Transmitting the Screen Data .....	123
6-7	Setting Conditions for Communications with Host by Using Memory Switches .....	125
6-7-1	About Communication Conditions .....	125
6-7-2	Setting the Host Link Method .....	127
6-7-3	Setting the 1:1 NT Link Method .....	129
6-7-4	Setting the 1:N NT Link Method (Standard/High-speed) .....	129
6-7-5	Setting the Memory Link Method .....	132
6-8	Starting Operation .....	133
6-9	System Settings .....	134
6-9-1	Memory Switch Setting Screens .....	134
6-9-2	Setting the Start-up Wait Time .....	136
6-9-3	Setting the Key Press Sound .....	136
6-9-4	Setting the Buzzer Sound .....	137
6-9-5	Setting a Battery Check .....	137
6-9-6	Setting the Screen Saver Timer .....	138
6-9-7	Setting the History Display Method .....	139
6-9-8	Setting the Resume Function (Battery Required) .....	140
6-9-9	Setting the Automatic Reset Function .....	141
6-9-10	Setting the Time-out Interval .....	142
6-9-11	Setting the Retry Count .....	142
6-10	Setting the Bar Code Reader Input Function .....	144
6-11	System Maintenance .....	147
6-11-1	Displaying/Setting the Calendar and Clock .....	147
6-11-2	Checking the PT Setting Status .....	149
6-11-3	Displaying the Display History Record .....	150
6-11-4	Displaying the Alarm History Record .....	151
6-11-5	Checking Screen Data .....	153
6-11-6	Device Check .....	156
6-11-7	Checking Interfaces .....	161



6-12	Programming Console Function .....	165
6-12-1	Compatible Systems .....	167
6-12-2	Connection Method .....	168
6-12-3	Method of Use .....	169
6-13	Version Display .....	171
6-13-1	Method of Use .....	172

## 6-1 System Menu Operation Flow

Follow the procedure below when using the NT21 for the first time or changing the system program.

### Create the Screen Data



Create the data to be displayed on the NT21 by using the NT Support Tool.

For details on creating screen data, refer to the *NT-series Support Tool Ver. 4.6 for Windows Operation Manual (V061-E1-□)*.

### Start Up the NT21 (Display the System Menu) (page 104)



Turn ON the power to the NT21.

If no screen data has been registered, an error message is displayed. In this case, press the OK touch switch on the error message screen to display the System Menu.

If screen data has been registered and the RUN mode is established, perform the appropriate operations on the touch panel to display the System Menu.

### Initialize the Memory (page 110)



If necessary, initialize the memory of the NT21 by operation from the System Menu.

### Transmit the Screen Data (page 123)



Connect the NT Support Tool to the NT21 and transmit the screen data from the NT Support Tool to the NT21.

For details on connecting the NT Support Tool, refer to *3-3 Connecting to the NT Support Tool (page 28)*.

### Set the Memory Switches (pages 125, 134, 144)



Select the System Menu and set the operations of the NT21 — for example the conditions for communication with the host — using the memory switches.

### Start Operation (page 133)



Connect the NT21 to the host and start operation.

### System Maintenance (page 147)

If an error occurs during operation, check the I/Os, settings, etc., by referring to this guide.

#### **Screen Display when Shipping**

The following figure shows the screen display that appears when the PT is shipped. Normal screen data is not installed after inspection, resulting in this message. This message does not indicate mechanical or other problems.

Press the OK Button at the bottom right and follow the messages that appear on the screen.

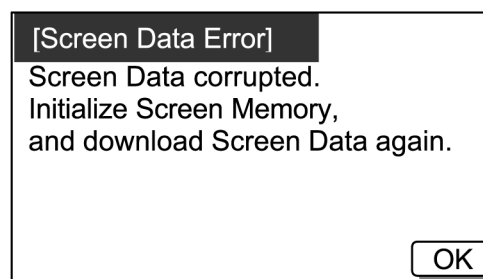

## 6-2 Starting the NT21

After checking that the hardware has been connected correctly, switch on the power to the NT21 to start it up.

This section describes the operation of the NT21 when it is started up.

### 6-2-1 Operation at Startup

The NT21 operates as follows when the power is switched ON.

#### Initial Processing



Self-checking — including a check on the internal memory of the NT21 and a system program check — and the internal processing required for startup, is performed.

If an error occurs during initial processing, an error screen is displayed.

If there is an error in the system program, the system program must be re-installed. For details on the installation procedure, refer to *6-5 Operations in the System Installer Mode* (page 118).

#### Memory Unit Check



Check if a Memory Unit is installed. If a Memory Unit is installed, processing (screen data and system program reading/writing) is executed in accordance with its DIP switch settings (page 31).

#### Screen Data and System Program Checks



If there is an error in the screen data stored in the NT21, an error screen is displayed. Pressing the OK touch switch on the error screen will return the display to that just before the error occurred. It is also possible to display the System Menu from the error screen by pressing two of the four corners of the touch panel simultaneously. If there is an error in the system program, the main menu of the system installer mode is displayed. In this case, reinstall the proper system program.

Initialize the memory or change the settings as required.

#### Start of Communication with the Host



Communication with the host starts in accordance with the communication method set in the system memory of the NT21. During the interval until communication is established, the system initialization screen (screen No. 9000) is displayed.

For details, refer to *6-8 Starting Operation* (page 133).

When communications cannot be established properly, the system initialization screen will remain on. In this case, display the System Menu by pressing two of the four corners of the touch panel simultaneously, and check the settings for the communication conditions for communication with the host again. Also check the communications cables and connections.

#### Operation Start

The RUN mode is established, and operation starts in accordance with the screen data in the NT21.

When changing the settings or checking the statuses, perform the appropriate operation by displaying the System Menu. For details on displaying the System Menu, refer to *6-3-3 Operations with the System Menu* (page 108).

## 6-3 Operation Modes and the System Menu

The NT21 operates in four modes: the RUN, Transmit, Maintenance, and Expansion modes. These modes are selected from the System Menu.

In addition, the NT21 also features the System Installer mode, which is used specifically for installing the system program.

The System Installer mode is selected by operation at the panel when the NT21 power is switched ON.

### 6-3-1 Relationships among Modes

The relationships among the System Menu, each of the operation modes, and the System Installer mode, are indicated in the figure below.

For details on system menu operation, refer to 6-3-3 *Operations with the System Menu* (page 108).

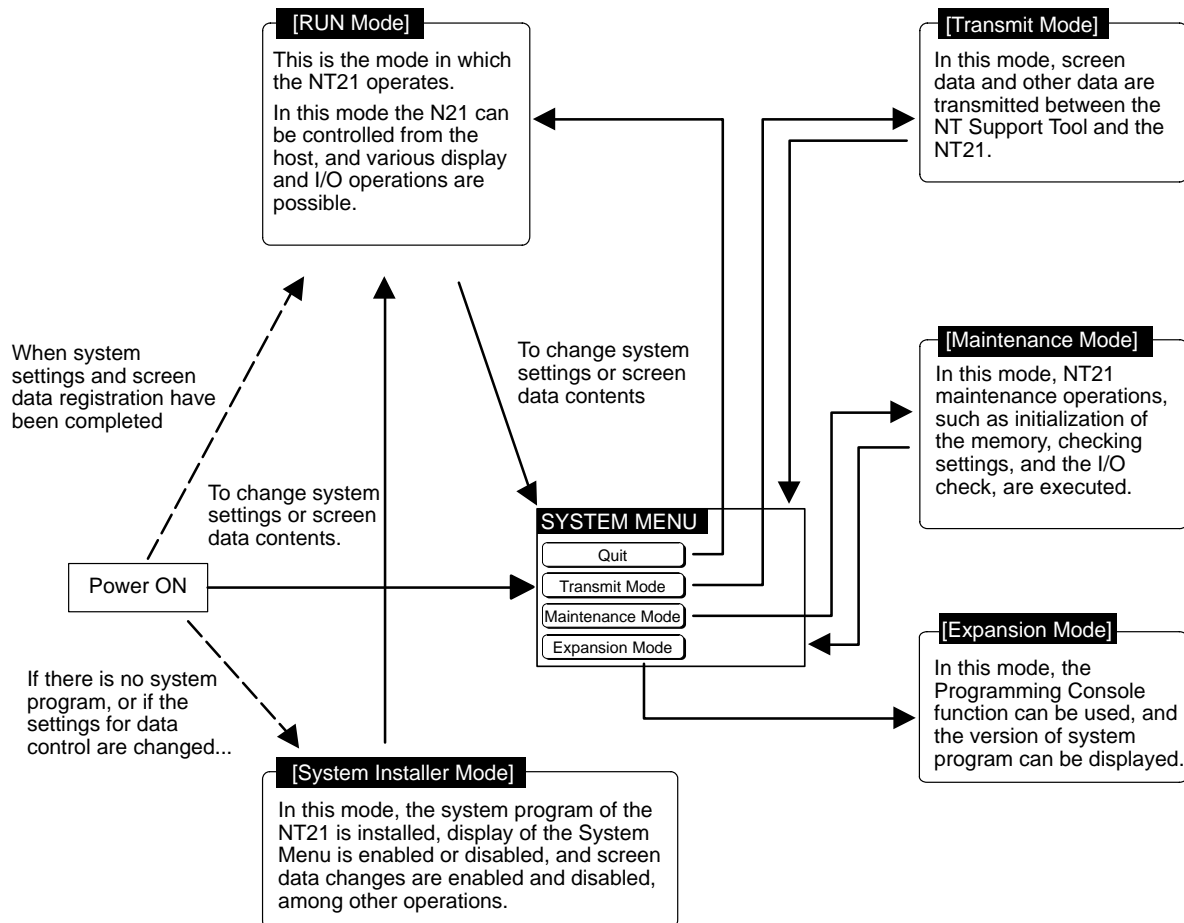

**Items in the System Menu**

The items displayed in the system menu and their functions are as follows.

Menu Item	Function
Quit	Clear the System Menu screen and return to the RUN mode screen.
Transmit Mode	Display the Transmit Mode screen to allow transmission for screen data between the NT Support Tool and the NT21. For details on transmission of screen data, refer to 6-6 <i>Transmitting the Screen Data</i> (page 123).
Maintenance Mode	Display the Maintenance Mode menu to allow system maintenance of the NT21, and various NT21 settings.
Expansion Mode	Display the Expansion Mode menu to perform selection of the expansion functions supported by the NT21. The following expansion functions are supported: <ul style="list-style-type: none"> <li>• Version Display Displays the version of system program, the date it was created, and the PT model. For details, refer to 6-13 <i>Version Display</i>.</li> <li>• Programming Console Function Allows the NT21 to be used as a Programming Console for a CS1G/CS1H, CS1G-H/CS1H-H, CJ1G, CPM1, CPM2A, CPM2C, CQM1, CQM1H, C200HX/HG/HE(-Z), or SRM1. For details, refer to 6-12 <i>Programming Console Function</i>.</li> </ul>

**Functions of the System Installer Mode**

The following functions can be executed in the System Installer mode.

- Setting the display language
- Clearing and installing system programs
- Disabling/enabling display of the System Menu.
- Disabling/enabling writing to the screen data memory
- Clearing screen data

For details on these functions, refer to 6-5 *Operations in the System Installer Mode* (page 118).

### 6-3-2 Menu Tree

The System Menu allows the various functions of the NT21 to be executed by using touch switches displayed on the touch panel. The menu tree, starting from the System Menu, is shown below.

For details on System Menu operations, refer to 6-3-3 *Operations with the System Menu* (page 108).

The menu tree may differ according to the system program installed in the NT21. The menu tree for the system program that is installed in the NT21 on shipment is shown below.

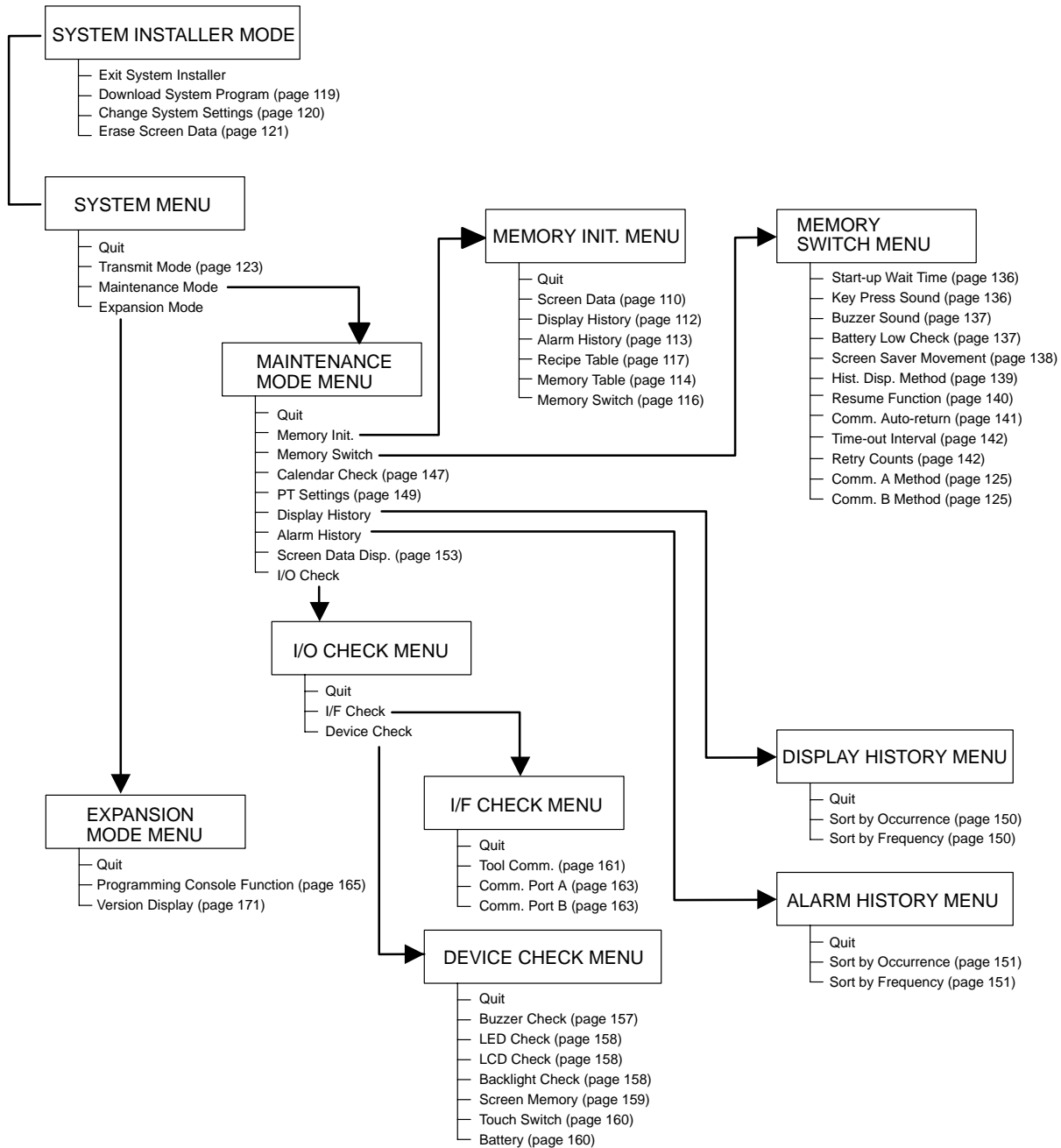

### 6-3-3 Operations with the System Menu

This section describes how to use the menus, including how to call the System Menu, how to call the System Installer mode, and how to select menu items.

#### Calling the System Menu

The System Menu can be displayed by either of the following two methods.

- Touching the corners of the touch panel
- Pressing a touch switch that displays the System Menu

#### Reference:

- If display of the System Menu is prohibited by the setting made in the System Installer mode, the System Menu cannot be displayed (this does not apply if an error has occurred).
- At the same as the System Menu is displayed, the operation of the NT21 stops and the RUN Indicator goes OFF.

#### Touching the Corners of the Touch Panel

When two of the four corners of the touch panel (see the figure below) are touched simultaneously, the System Menu is displayed.

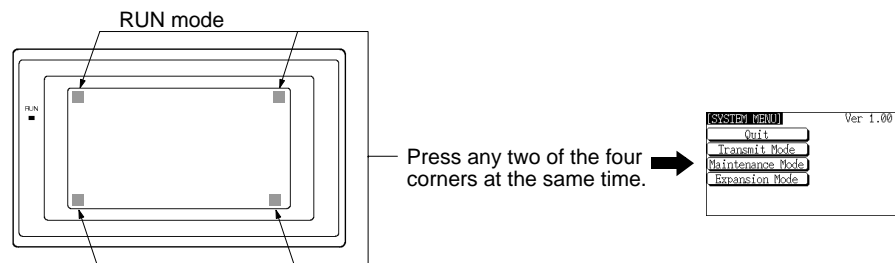

Note that the touch switches used to call the System Menu are not displayed at corners on the screen. If a touch switch displayed in a corner is pressed first, the touch switch will function and the System Menu will not be displayed. In particular, when the touch switch has switch screen function, as a result of screen switch over, it means the corner is not pressed even if it is kept pressing. To successfully call the System Menu, first press a corner where no touch switch is displayed, and then press any other corner regardless of the presence of a touch switch.

- Reference:** With the NT21, the System Menu can be displayed even if the screen has touch switches registered at all four corners.

#### Pressing a Touch Switch That Displays the System Menu

There is a control key that has the function of displaying the System Menu.

By registering a touch switch for the System Menu display ([MENU]) on a screen when creating it, the System Menu can be displayed just by pressing this switch.

#### Selecting Menu Items

The menu items in the System Menu are displayed on the NT21 screen as touch switches. Menu items can be selected simply by pressing them.

**Example:** Displaying the MAINTENANCE MODE MENU screen by pressing Maintenance Mode in the System Menu.

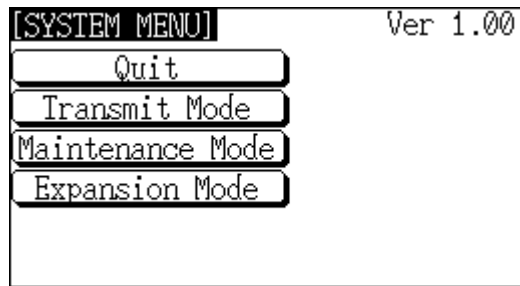

Press Maintenance Mode.

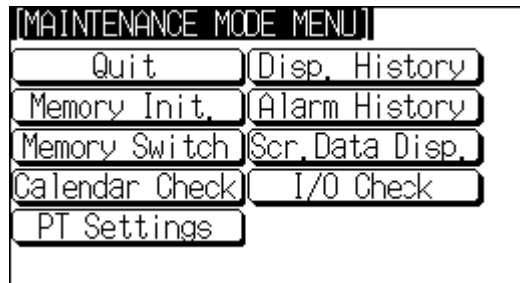

**Returning from the System Menu to the RUN Mode**

Return to the RUN mode by selecting Quit in the System Menu and other menus.

---

**Reference:** The NT21 does not return to the RUN mode automatically if no operations are performed.

---



## 6-4 Memory Initialization

The NT21 has the following initialization functions. Use them as necessary.

- Clearing screen data Page 110
- Initializing memory tables Page 114
- Initializing memory switches Page 116
- Initializing display history record data Page 112
- Initializing alarm history record data Page 113
- Initializing recipe tables Page 117

---

**Reference:** If writing to the screen data memory is prohibited by the System Setting setting in the System Installer mode, memory initialization is not possible.

---

### 6-4-1 Clearing Screen Data

Use this function if the screen data has been corrupted and the NT21 cannot be started up correctly.

This operation clears (initializes) only the screen data and contents of the mathematical table. The memory switch settings, display history data, alarm history record data, and recipe data are retained.

- 
- Reference:**
- When this function is used, all of the screen data contents registered in the NT21 up to that point are cleared. Check that the created screens are backed up at the NT Support Tool before using it.
  - The screen data can be cleared in the System Installer mode too (page 119).
  - The following types of data can be initialized individually.
    - Contents of numeral and character string memory tables (page 113)
    - Memory switch settings (page 114)
    - Display history record data (page 112)
    - Alarm history record data (page 113)
    - Recipe data (page 117)
-

Clear the screen data by following the menu operations from the Maintenance Mode Menu as shown below.

[MAINTENANCE MODE MENU]	
Quit	Disp. History
Memory Init.	Alarm History
Memory Switch	Scr. Data Disp.
Calendar Check	I/O Check
PT Settings	

Select Memory Init..



[MEMORY INIT. MENU]	
Quit	Memory Switch
Screen Data	Recipe Table
Disp. History	
Alarm History	
Memory Table	

Select Screen Data.



<SCREEN DATA ERASURE>	
Erase Screen Data?	
Yes	No

Select Yes.

The screen data is cleared. During clearance, the message Erasing Now... is displayed.

If No is selected, the NT21 returns to the MEMORY INIT. MENU screen without clearing the screen data.

On completion of screen data clearance, the NT21 returns to the MEMORY INIT. MENU screen.

After the screen data has been cleared, if an attempt is made to set the NT21 to the RUN mode before screen data has been transmitted from the NT Support Tool or Memory Unit, an error message will be displayed and the RUN mode will not be established.

## 6-4-2 Initializing Display History Record Data

The display history record function keeps a record of the order of display of the screens displayed during operation, and the number of times each screen is displayed. These records are kept only for screens for which the History attribute has been set.

The maximum number of records is 1024 for sort by occurrence (order of display occurrence) and 255 for sort by frequency (order of the number of times each screen has been displayed).

Use the display history record initialization function to clear the history record data to 0, for example when the screen data has been changed, etc. Also, if Display History (Use Ring Buffer) under History Setting of System in PT Configuration (Tools) has not been checked, no more records will be stored after the maximum number of records has been kept, and therefore the records must be periodically initialized. If Display History (Use Ring Buffer) is checked, when the maximum number of records is reached the oldest record is deleted and the newest data is recorded.

- 
- Reference:**
- The NT21 also allows the display history record data to be initialized by controlling the PT Status Control Area from the host. For details, refer to 2-2-1 *PT Status Control Area* in the *Reference Manual*.
  - If the optional battery is not installed, the display history record data will be initialized when the PT's power is turned OFF.
-

Initialize the display history record data by following the menu operations from the Maintenance Mode Menu as shown below.

[MAINTENANCE MODE MENU]	
Quit	Disp. History
Memory Init.	Alarm History
Memory Switch	Scr. Data Disp.
Calendar Check	I/O Check
PT Settings	

Select Memory Init..



[MEMORY INIT. MENU]	
Quit	Memory Switch
Screen Data	Recipe Table
Disp. History	
Alarm History	
Memory Table	

Select Display History.



<DISPLAY HISTORY INIT.>	
Initialize Display History?	
Yes	No

Select Yes.

The display history record data is initialized. During initialization, the message Initializing is displayed.

If No is selected, the NT21 returns to the MEMORY INIT. MENU screen without initializing the display history record data.

On completion of display history record data initialization, the message Finished is displayed and the NT21 returns to the MEMORY INIT. MENU screen.

### 6-4-3 Initializing Alarm History Record Data

The alarm history record function continually checks the status of host bits that have been designated in advance in the bit memory table, and records the time when any of the bits is set to 1 (comes ON), and the number of times that each bit comes ON.

The maximum number of records is 256 for sort by occurrence (order of error occurrence) and 255 for sort by frequency (order of the number of times each error has occurred).

Use the alarm history record initialization function to reset the alarm history record data to 0, for example when the screen data has been changed, etc. Also, if Alarm History (Use Ring Buffer) under History Setting in the PT Environment Settings – System Settings has not been checked, no more records will be stored after the maximum number of records has been kept, and therefore the records must be periodically initialized. If Alarm History (Use Ring Buffer) is checked, when the maximum number of records is reached the oldest record is deleted and the newest data is recorded.

- Reference:**
- The NT21 also allows the alarm history record data to be initialized by controlling the PT Status Control Area from the host. For details, refer to 2-2-1 PT Status Control Area in the Reference Manual.
  - If the optional battery is not installed, the alarm history record data will be initialized when the PT's power is turned OFF.

Initialize the alarm history record data by following the menu operations from the Maintenance Mode Menu as shown below.

Select Memory Init..



Select Alarm History.



Select Yes.

The alarm history record data is initialized. During initialization, the message Initializing is displayed.

If No is selected, the NT21 returns to the MEMORY INIT. MENU screen without initializing the alarm history record data.

On completion of alarm history record data initialization, the message Finished is displayed and the NT21 returns to the MEMORY INIT. MENU screen.

#### 6-4-4 Initializing the Memory Tables

It is possible to initialize the numeral memory table and character string memory table in the NT21.

When these tables are initialized, the values are returned to those set by the NT Support Tool (they are not cleared).

When the memory tables are initialized, they are returned to their initial values regardless of the setting made for the resume function (page 140).

If ON is set for the Resume Function memory switch, the initial values set with the NT Support Tool will not be recorded in the memory tables unless they are initialized.

- Reference:**
- If the Resume Function memory switch is set to OFF, the memory tables can be initialized just by switching the NT21 power OFF and back ON again (page 140).
  - The bit memory table merely reflects the status of bits at the host and therefore cannot be initialized.
  - If the optional battery is not installed, the memory tables will be initialized when the PT's power goes OFF even if the Resume Function memory switch is ON.

Initialize the memory tables by following the menu operations from the Maintenance Mode Menu as shown below.

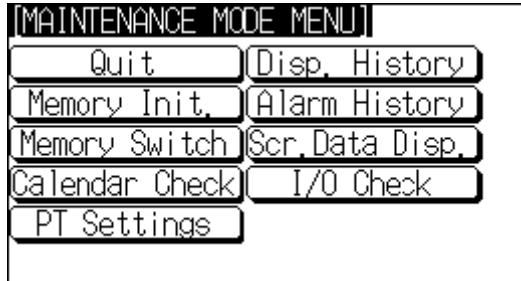

Select Memory Init..

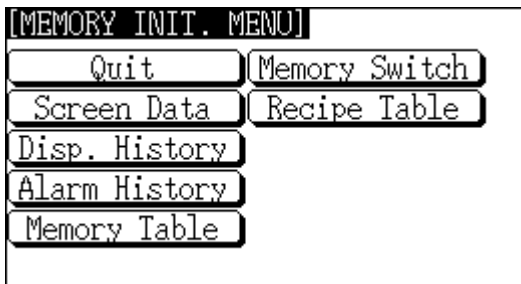

Select Memory Table.

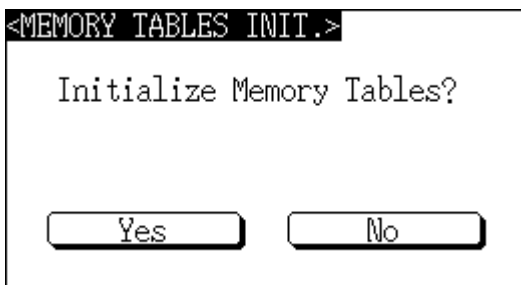

Select Yes.

The memory tables are initialized. During initialization, the message Initializing is displayed.

If No is selected, the NT21 returns to the MEMORY INIT. MENU screen without initializing the memory tables.

On completion of memory table initialization, the message Finished is displayed and the NT21 returns to the MEMORY INIT. MENU screen.

## 6-4-5 Initializing the Memory Switches

Initialization returns all the memory switches of the NT21 to their status on shipment.

Initialize the memory switches by following the menu operations from the Maintenance Mode Menu as shown below.

[MAINTENANCE MODE MENU]	
Quit	Disp. History
Memory Init.	Alarm History
Memory Switch	Scr. Data Disp.
Calendar Check	I/O Check
PT Settings	

Select Memory Init..



[MEMORY INIT. MENU]	
Quit	Memory Switch
Screen Data	Recipe Table
Disp. History	
Alarm History	
Memory Table	

Select Memory Switch.



<MEMORY SWITCHES INIT.>	
Initialize Memory Switches?	
Yes	No

Select Yes.

The memory tables are initialized. During initialization, the message Initializing is displayed.

If No is selected, the NT21 returns to the MEMORY INIT. MENU screen without initializing the memory switches.

On completion of memory switch initialization, the message Finished is displayed and the NT21 returns to the MEMORY INIT. MENU screen.

After initialization, the memory switch statuses are as follows.

Memory Switch	Status
Start-up Wait Time	00
Key Press Sound	ON
Buzzer Sound	OFF
Battery Check	OFF
Screen Saver Movement	Display erased
Screen Saver Start up Time	010
Hist. Disp. Method	From New Data
Resume Function	OFF
Comm. Auto-return	OFF
Time-out Interval	01
Retry Counts	005
Comm. A Method	Host Link (baud rate = 9,600 bps)*
Comm. B Method	None

\* The communication conditions for a bar code reader are initialized as follows:  
Data bits: 7 bits; stop bits: 1 bit; parity: none; flow control: RS/CS.

## 6-4-6 Initializing the Recipe Tables

You can initialize the recipe tables (i.e., all the recipe data) edited in the NT21. Here, "initializing" the recipe tables means to restore the battery backup memory ("recipe data memory") to the values in flash memory at that time. If, after downloading from the NT Support Tool, you do not upload the data even once, initialization will restore the initial values set using the NT Support Tool. The values will not be cleared.

**Reference:** If the optional battery is not installed, the recipe data will be initialized when the PT's power is turned OFF.



Initialize the recipe tables by following the menu operations from the Maintenance Mode Menu as shown below.

```

[MAINTENANCE MODE MENU]
  Quit      Disp. History
Memory Init. Alarm History
Memory Switch Scr. Data Disp.
Calendar Check I/O Check
PT Settings
  
```

Select Memory Init..



```

[MEMORY INIT. MENU]
  Quit      Memory Switch
Screen Data Recipe Table
Disp. History
Alarm History
Memory Table
  
```

Select Recipe Table.



```

<RECIPE TABLE INIT.>
  Initialize Recipe Table?

  Yes      No
  
```

Select Yes.

The recipe tables are initialized. During initialization, the message Initializing is displayed.

If No is selected, the NT21 returns to the MEMORY INIT. MENU screen without initializing the recipe tables.

On completion of memory table initialization, the message Finished is displayed and the NT21 returns to the MEMORY INIT. MENU screen.

## 6-5 Operations in the System Installer Mode

The following functions can be executed in the System Installer mode:

- Clearing/installing the system program (page 119)
- Disabling/enabling display of the System Menu (changing the system settings) (page 120)
- Disabling/enabling writing to the screen data memory (changing the system settings) (page 120)
- Clearing screen data (page 121)

### 6-5-1 Calling the System Installer Mode

If the NT21 has no system program installed, or if the system program is corrupted, the System Installer mode is automatically established when the power is switched ON.

When it is necessary to install the system program or make settings for data management, press and hold the touch switch in the top left corner of the touch panel (size: 9 mm × 9 mm) and turn ON the NT21.

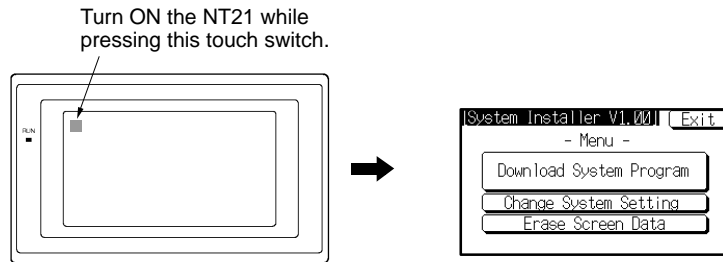

### 6-5-2 Clearing/Installing the System Program

Use this function when the system program of the NT21 has been corrupted, or when installing a new system program.

- Reference:**
- In order to install a system program, the system installer must also be installed at the NT Support Tool. The system installer is an accessory with the NT Support Tool (NT-ZJCAT1-EV5). When installing the NT Support Tool in a personal computer, install the system installer also. For details on the method for installing the system installer at the NT Support Tool side, and the operating procedure, refer to the *NT-series Support Tool Ver. 5 for Windows Operation Manual* (V070-E1-□).
  - When the system program is cleared by mistake, it becomes impossible to use the NT21 at all. Check that the system installer is installed at the NT Support Tool side before deleting the program. However, note that the registered screen data and memory switch settings are retained.
  - The system program in the Memory Unit can be installed automatically by starting the PT with the Memory Unit installed. (Refer to 3-5 *Using a Memory Unit*.)

Clear/install the system program by following the menu operation from the System Installer mode menu shown below.

#### Clearing the System Program

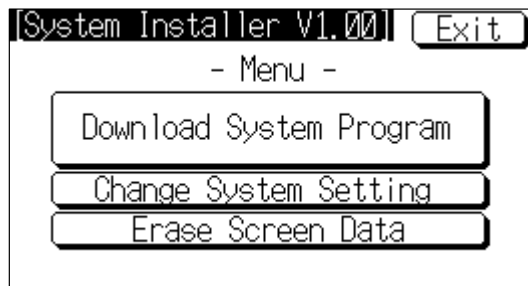

Select Download System Program.

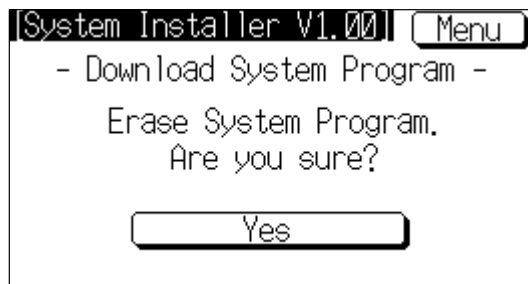

Select Yes.

The system program is cleared. During clearance, the message Erasing ... is displayed.

- If Return to Menu is selected, the NT21 returns to the System Installer mode menu without clearing the system program.
- If clearance fails, a screen asking whether you wish to try again is displayed. On completion of system program clearance, the NT21 enters the standby status for downloading of the system program.

### Downloading the System Program

On normal completion of system program clearance, the standby status for system program downloading is automatically established.



When the NT21 enters this status, transmit the system program from the system installer at the personal computer.

During downloading, the progress of transmission is indicated on the screen.



Select Run System.

If Abort is selected during standby for downloading or during downloading, a screen asking whether you wish to download again is displayed.

When the system program is started, the NT21 starts up normally. If no screen data has been registered, an error message will be displayed indicating that screen data hasn't been registered. Transfer the screen data and proceed.

**Reference:** If the new system program is not downloaded successfully after deleting a system program, it is not possible to use the NT21 at all. After deleting the system program, be sure to download a new one.

### 6-5-3 Changing the System Settings

The NT21 allows the following settings to be made to prevent the screen data and memory switch settings from being changed or deleted by operating errors.

#### **Disabling/enabling System Menu Display**

When System Menu display is disabled by this setting, the System Menu cannot be displayed by touch panel operations or by using the touch switches. However, if an error occurs, the System Menu can be displayed from the error message screen.

#### **Disabling/enabling Writing to the Screen Data Memory**

When writing to the screen data memory is disabled by this setting, it is impossible to use the following System Menu functions. It is possible, however, to clear the screen data in the system installer mode.

- Switching to the Transmit mode
- Displaying the memory switch setting screens
- Checking the screen data memory
- Displaying the initialization menu

Change the system settings by following the menu operation from the System Installer mode menu shown below.

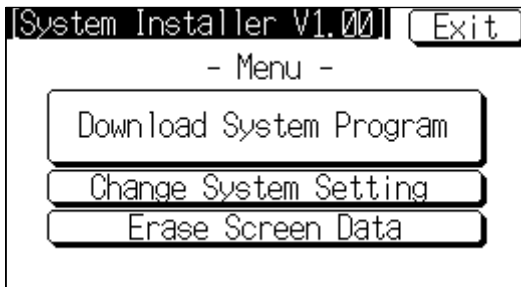

Select Change System Settings.

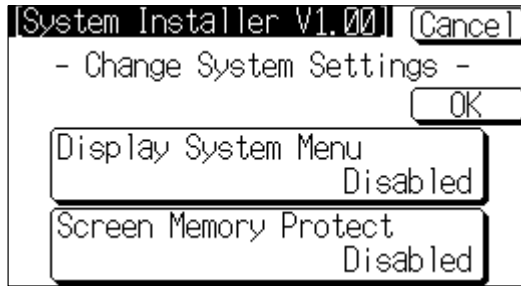

Select Display System Menu or Screen Memory Protect .

Each time either of these items is selected, the setting switches from Disabled to Enabled or vice versa.

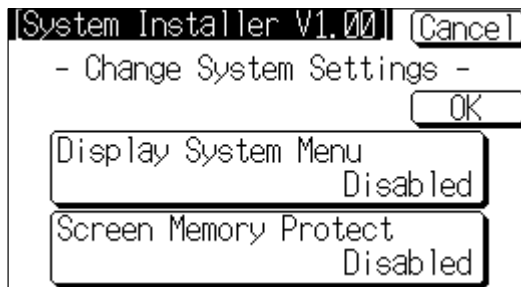

Select OK.

The settings are written to the NT21 while the screen is displayed.

- If Cancel is selected, the NT21 returns to the System Installer mode menu without changing the settings. The settings remain as they were before the operation was started.
- If writing of the settings fails, a screen asking whether you wish to try again is displayed.

After the settings have been written, the System Installer mode menu screen is redisplayed.

### 6-5-4 Clearing Screen Data

If the screen data has been corrupted and the NT21 cannot be started normally, use this function to clear the screen data.

Note that only the screen data is cleared (initialized); the memory switch settings, display history record data, alarm history record data, and recipe data are retained.

- Reference:**
- When this function is used, all of the screen data contents registered in the NT21 up to that point are cleared. Check that the created screens are backed up at the NT Support Tool before using it.
  - The screen data can also be cleared from the System Menu (page 110).
  - If the screen data is cleared in the System Installer mode, the message Screen Data Corrupted may be displayed on switching to the RUN mode. If this happens, initialize the screen data again from the MEMORY INIT. MENU screen.

Clear the screen data by following the menu operation from the System Installer mode menu shown below.

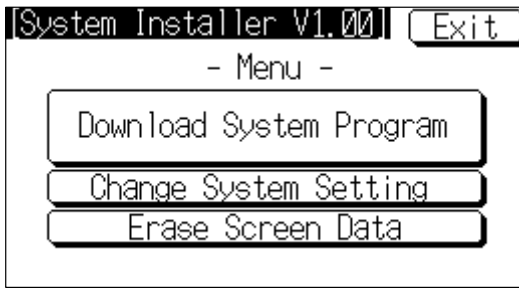

Select Erase Screen Data.

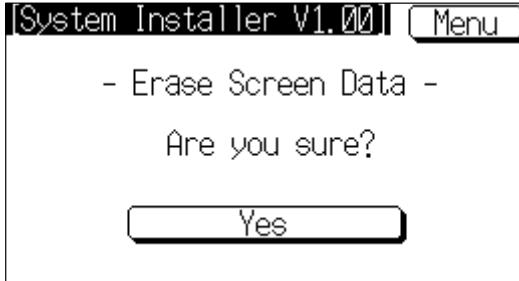

Select Yes.

The screen data is cleared. During clearance, the message Erasing ... is displayed.

- If Return to Menu is selected, the NT21 returns to the MEMORY INIT. MENU screen without clearing the screen data.
- If screen data clearance fails, a screen asking if you wish to try again is displayed.

On completion of screen data clearance, the NT21 returns to the System Installer mode menu screen.

After the screen data has been cleared, if an attempt is made to set the NT21 to the RUN mode before screen data has been transmitted from the NT Support Tool or Memory Unit, an error message will be displayed and the RUN mode will not be established.

## 6-6 Transmitting the Screen Data

The screen data is created with the NT Support Tool and then transmitted to the NT21. This section explains how to transmit the screen data.

For details on how to create the screen data and the operation of the NT Support Tool, refer to the *Reference Manual* and the *NT-series Support Tool Ver. 4.6 for Windows Operation Manual* (V061-E1-□).

- 
- Reference:**
- The screen data can be transmitted also from the Memory Unit installed in the NT21. For details on this method, refer to *3-5 Using a Memory Unit*.
  - The screen data can be transmitted at a faster rate by setting High for Baud Rate on the Comms. Setting... window of the NT Support Tool.
  - If writing to the screen data memory is disabled by the setting made for System Setting in the System Installer mode, screen data transmission is not possible.
- 

### Screen Data Composition and Transmission Units

The screen data comprises the following types of data.

- User screen data (screen units)
- System memory (memory switch) settings
- Direct connection information
- Numeral memory table data
- Character string memory table data
- Bit memory table data
- Mathematical table data
- Mark information
- Image/library data
- Recipe table data

It is possible to transmit the screen data (data for all the screens) in file units, or to transmit individual data or the data of individual screens in data units. (It is not possible to transmit mathematical table data in data units.)

When data is transmitted in file units, all of the screen data in the NT21 is cleared and then the new data is transmitted.

When data is transmitted in data units, first the previous data is invalidated, then the new data is registered as valid data. Since the previous data is not cleared, free memory area in the NT21 will be insufficient when transmissions in data units are repeated. If this happens, write the screen data again by data transmission in file units.

### Transmitting Screen Data from the NT Support Tool

To transmit screen data from the NT Support Tool to the NT21, follow the procedure below.

#### Operation

- 1, 2, 3... 1. Connect the NT21 to a personal computer in which the NT Support Tool has been installed and turn the power to the NT21 ON.
2. Turn ON the power to the personal computer and start up the NT Support Tool.

3. Establish the Transmit mode by following the menu operation from the System Menu shown below at the NT21.

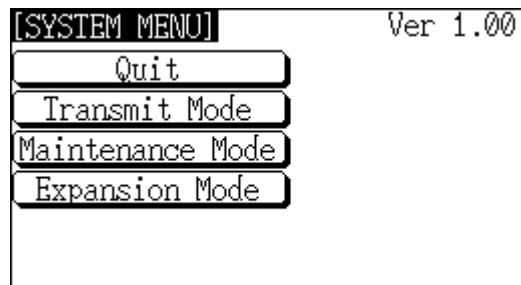

Select Transmit Mode.

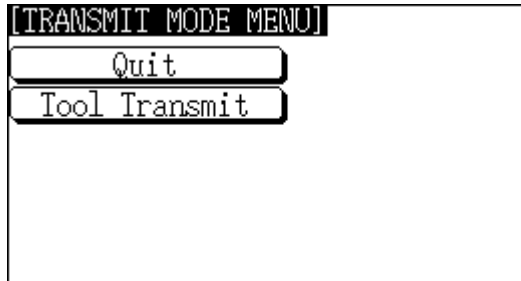

Select Tool Transmit.

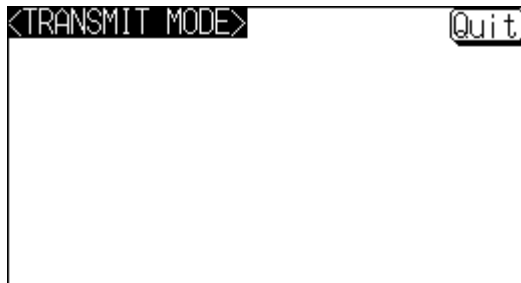

4. Open the screen data to be transmitted at the NT Support Tool, then select Download (NTST PT) in the NT Support Tool's Connect menu and specify the data to be transmitted.
5. During screen data transmission, the transmission status is displayed.
6. On completion of screen data transmission, press the Quit touch switch. The NT21 returns to the Transmit mode.

If the screen data cannot be successfully transmitted from the NT Support Tool, use the communication check functions of the NT21 to check if communication between the NT21 is normal or not (page 161).

If any of the following, or a system error, occurs during transmission of screen data, the transmitted screen data will not be registered correctly in the NT21. If this happens, the NT21 may not enter the RUN mode when started up, or there may be unpredictable malfunctions such as failure to display screens during operation. In this case, the screen data must be retransmitted in file units to register it correctly.

- The power to the NT21 is interrupted.
- The power to the personal computer on which the NT Support Tool is running is interrupted or the computer is reset.
- The cable connecting the NT21 to the personal computer on which the NT Support Tool is running is disconnected or has a broken wire.
- The Quit touch switch on the NT21 screen is pressed to end screen data transmission.

#### Precautions to Be Observed When Transmitting Screen Data

- Screen data transmission is stopped by operation at the NT Support Tool.

**Note** When transferring the data in units of screens, if there are changes in memory table and/or direct access, transfer such data along with the screen data. The system may operate unpredictably without this data.

## 6-7 Setting Conditions for Communications with Host by Using Memory Switches

The method for setting the communication method for communications with the host is described here.

For details on setting the communication conditions for a bar code reader, refer to 6-10 *Setting the Bar Code Reader Input Function* (page 144).

### 6-7-1 About Communication Conditions

#### Items Set for Communication Conditions

The following settings are made for the communication conditions for communication between the NT21 and the host.

#### **Port Communication Method/Communication Type Settings**

Setting Item	Function	Setting Options	Page
Comm. A Method	Set the communication method used at serial port A. Depending on the communication method, further communication condition settings may be necessary.	None/Host Link/NT Link (1:1)/NT Link (1:N) (standard or high-speed)/Bar-Code Reader Memory link	Page 127 Page 129 Page 129 Page 132
Comm. B Method	Set the communication method used at serial port B. Depending on the communication method, further communication condition settings may be necessary.	None/Host Link/NT Link (1:1)/NT Link (1:N) (standard or high-speed) Memory link	Page 127 Page 129 Page 129 Page 132

#### **Communication Condition Settings for the Host Link Method**

Setting Item	Function	Setting Options	Page
Comm. Speed (for host link only)	Sets the baud rate for communications with the host.	9,600 bps/ 19,200 bps	Page 127

#### **Communication Condition Settings for the 1:1 NT Link Method**

No further communication conditions need to be set.

#### **Communication Conditions Settings for the 1:N NT Link Method**

Setting Item	Function	Setting Options	Page
Unit No. (for 1:N NT Link only)	Set the unit number of the NT21.	0 to 7	Page 129
Comm. Speed	Sets the baud rate for communications with the host.	Standard or high-speed	



**Setting the Conditions for Communications with the Memory Link Method**

Setting Item	Function	Setting Options	Page
Data bits	Set the data bits length.	7, 8 bits	Page 132
Stop bits	Set the stop bits length.	1, 2 bits	
Parity	Set the parity.	None, even, odd	
Comm. Speed	Set the baud rate for communications with the host.	1200, 2400, 4800, 9600, 19200, 38400 bps	
Flow control	Set the flow control and its method.	None, RS/CS, XON/XOFF	
Response	Set whether the response is carried out for normal process of communication command or not.	Yes, No	

**Possible Combinations of Communication Method Settings**

The combinations of communication methods that can be set with the NT21 are indicated in the table below. Combinations other than these listed below cannot be set.

Port A \ Port B	None	Host Link	1:1 NT Link	1:N NT Link	Bar-code reader	Memory Link
None	○	○	○	○	○	○
Host Link	○	×	×	×	○	×
1:1 NT Link	○	×	×	×	○	×
1:N NT Link (Standard or high-speed)	○	×	×	×	○	×
Memory Link	○	×	×	×	○	×

○: Possible combination

×: Impossible combination

Combinations other than those indicated above cannot be set.

**Reference:** When using serial port B for communication with the host, and serial port A for the transmission of screen data from the NT Support Tool, set the settings of serial port A to None.

### 6-7-2 Setting the Host Link Method

Set the communication conditions for the host link method at serial port A or serial port B by following the menu operations from the Maintenance Mode Menu as shown below.

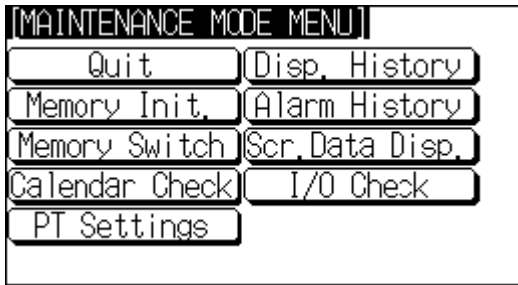

Select Memory Switch.

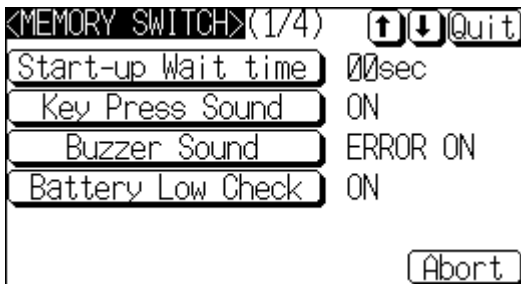

Display the fourth memory switch screen by pressing the [↓] (next screen) or [↑] (previous screen) touch switch.

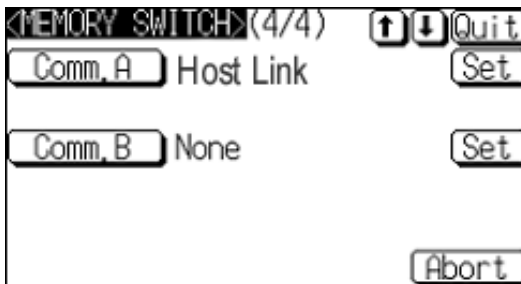

Press the touch switch corresponding to the port at which the host link method is to be set (Comm. A Method or Comm. B Method) to display the setting option Host Link.

The communications method setting on the right will change each time that the touch switch is pressed.



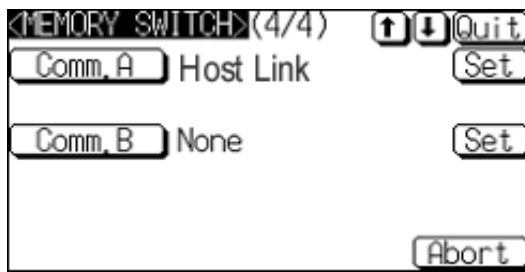

Press the Set touch switch to the right of the port at which the setting has been made.  
In this example, serial port A is used.



Press the Comm. Speed touch switch to display the baud rate to be set.

The setting option changes each time the touch switch is pressed.

In this example, serial port A is used.



Press Quit.

The baud rate is set.

- To quit the baud rate setting screen without setting the baud rate, press the Abort touch switch. The NT21 returns to the memory switch setting screen (4/4) and the previous baud rate remains in effect.

On completion of baud rate setting, the NT21 returns to the memory switch setting screen (4/4).

To set other memory switches, select the relevant screen using the [↓] (next screen) or [↑] (previous screen) touch switch, then make the setting.

- To confirm the settings and quit the memory switch setting screen, press the Quit touch switch. The settings made last will be set and the NT21 will return to the MAINTENANCE MODE MENU screen.

If the combination of settings for serial port A and serial port B is not allowed, an error message (indicating that the protocol settings are incorrect) will be displayed when the Quit touch switch is pressed. In this case, correct the settings to a combination that is allowed.

- To quit the memory switch setting screen without confirming the settings, press the Abort touch switch. The NT21 will return to the MAINTENANCE MODE MENU screen with the previous settings still in effect.

### 6-7-3 Setting the 1:1 NT Link Method

Set the communication conditions for the 1:1 NT Link method at serial port A or serial port B by following the menu operations from the Maintenance Mode Menu as shown below.

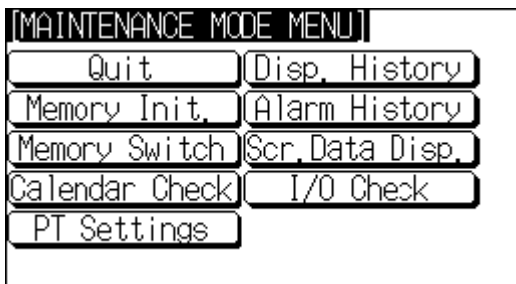

Select Memory Switch.

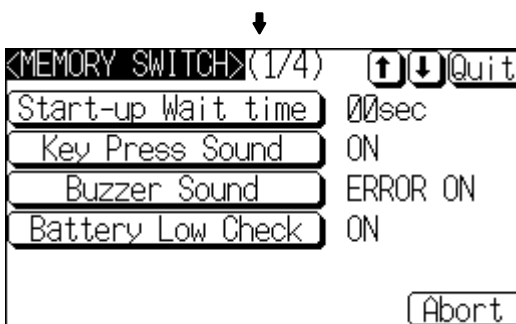

Display the fourth memory switch screen by pressing the [↓] (next screen) or [↑] (previous screen) touch switch.

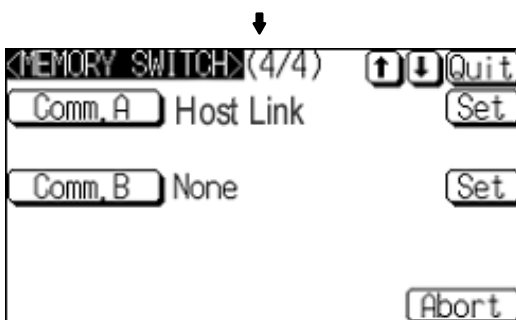

Press the touch switch corresponding to the port at which the 1:1 NT Link method is to be set (Comm. A Method or Comm. B Method) to display the setting option NT Link (1:1).

The communications method setting on the right will change each time that the touch switch is pressed.

To set other memory switches, select the relevant screen using the [↓] (next screen) or [↑] (previous screen) touch switch, then make the setting.

- To confirm the settings and quit the memory switch setting screen, press the Quit touch switch. The settings made last will be set and the NT21 will return to the MAINTENANCE MODE MENU screen.

If the combination of settings for serial port A and serial port B is not allowed, an error message (indicating that the protocol settings are incorrect) will be displayed when the Quit touch switch is pressed. In this case, correct the settings to a combination that is allowed.

- To quit the memory switch setting screen without confirming the settings, press the Abort touch switch. The NT21 will return to the MAINTENANCE MODE MENU screen with the previous settings still in effect.

### 6-7-4 Setting the 1:N NT Link Method (Standard/High-speed)

Set the communication conditions for the 1:N NT Link method at serial port A or serial port B by following the menu operations from the Maintenance Mode Menu as shown below.

The baud rate determines whether the 1:N NT Link is standard or high-speed.

Standard: Standard 1:N NT Link  
 High-speed: High-speed 1:N NT Link

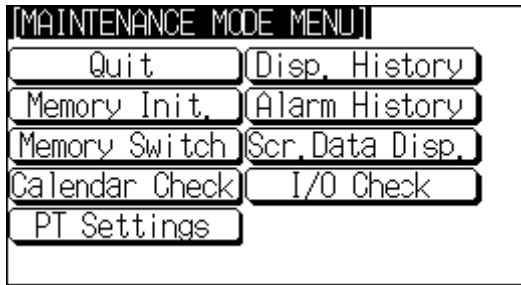

Select Memory Switch.

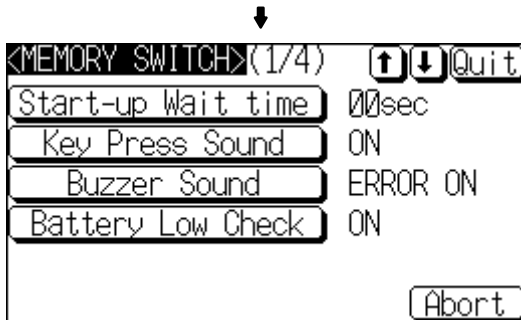

Display the fourth memory switch screen by pressing the [↓] (next screen) or [↑] (previous screen) touch switch.

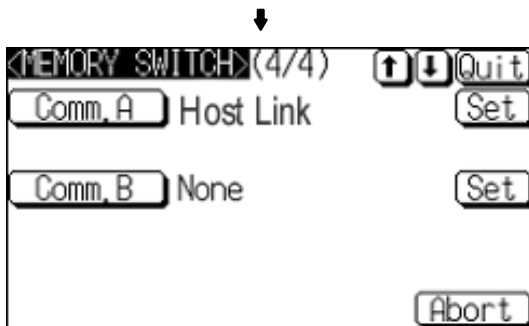

Press the touch switch corresponding to the port at which the 1:N NT Link method (standard or high-speed) is to be set (Comm. A Method or Comm. B Method) to display the NT Link (1:N) setting option.

The communications method setting on the right will change each time that the touch switch is pressed. In this example, serial port A is used.

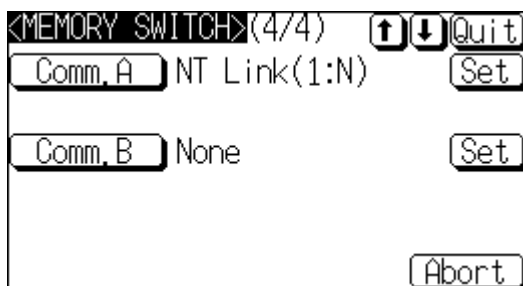

Press the Set touch switch to the right of the port at which the setting has been made. In this example, serial port A is used.

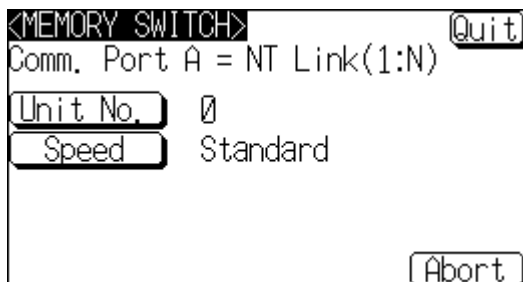

Press the Unit No. touch switch to display the unit number to be set. Press the Comm. Speed touch switch to display the baud rate, standard or 115.2-kbps high-speed. (The Comm. Speed setting determines which method of 1:N NT Link is used.)

The communications setting on the right will change each time that the touch switch is pressed. In this example, serial port A is used for a standard 1:N NT Link.

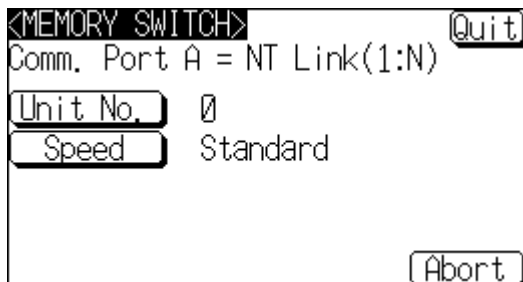

Press Quit.

The unit number and baud rate are set.

- To quit the unit number/baud rate setting screen without confirming the unit number/baud rate settings, press the Abort touch switch. The NT21 will return to the memory switch setting screen (4/4) with the previous settings still in effect.

**Reference:** Unit numbers are numbers assigned to each PT when multiple PTs are connected to one host, so that the host can identify the individual PTs. The unit numbers that can be set differ according to the host model, as follows.

- C200HE(-ZE):  
Unit numbers 0 to 3 (maximum of 4 PTs per host port)
- C200HG(-ZE), C200HX(-ZE), CS1G/H(-H), CJ1G, CQM1H:  
Unit numbers 0 to 7 (maximum of 8 PTs per host port)

When making the settings, make sure there is no duplication of unit numbers among PTs.

On completion of unit number/baud rate setting the NT21 returns to the memory switch setting screen (4/4).

To set other memory switches, select the relevant screen using the [↓] (next screen) or [↑] (previous screen) touch switch, then make the setting.

- To confirm the settings and quit the memory switch setting screen, press the Quit touch switch. The settings made last will be set and the NT21 will return to the MAINTENANCE MODE MENU screen.

If the combination of settings for serial port A and serial port B is not allowed, an

error message (indicating that the protocol settings are incorrect) will be displayed when the Quit touch switch is pressed. In this case, correct the settings to a combination that is allowed.

- To quit the memory switch setting screen without confirming the settings, press the Abort touch switch. The NT21 will return to the MAINTENANCE MODE MENU screen with the previous settings still in effect.

### 6-7-5 Setting the Memory Link Method

Set the communication conditions for the host link method at serial port A or serial port B by following the menu operations from the Maintenance Mode Menu as shown below. Check the communication settings of the host to be used.

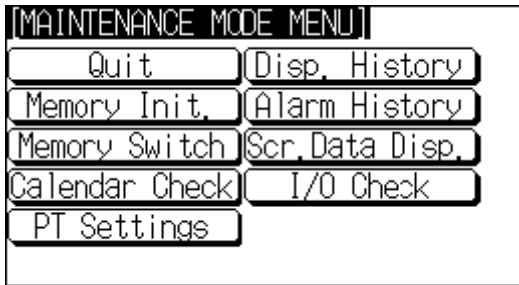

Select Memory Switch.

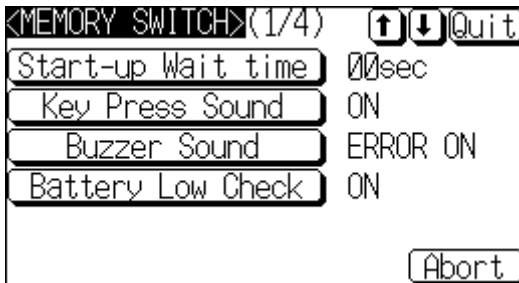

Display the fourth memory switch screen by pressing the [↓] (next screen) or [↑] (previous screen) touch switch.

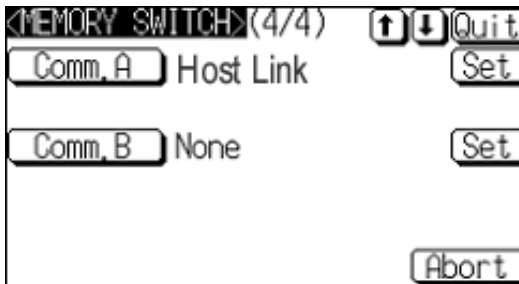

Press the touch switch corresponding to the port at which the memory link method is to be set (Comm. A Method or Comm. B Method) to display the setting option Memory Link.

The communications setting on the right will change each time that the touch switch is pressed.

In this example, serial port A is used.

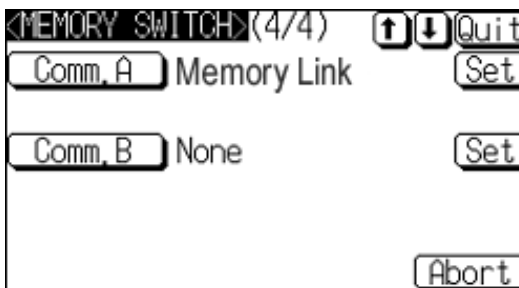

Press the Set touch switch to the right of the port at which the setting has been made.

In this example, serial port A is used.



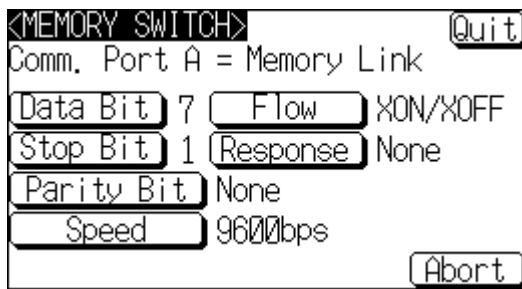

Display the data bits to be set (7 bits or 8 bits) by pressing the Data Bit Length touch switch.

Display the stop bits to be set (1 bit or 2 bits) by pressing the Stop Bit Length touch switch.

Display the parity to be set (None, even, odd) by pressing the Parity Bit touch switch.

Display the baud rate to be set (1200, 2400, 4800, 9600, 19200, 38400 bps.) by pressing the Comm. Speed touch switch.

Display the condition of the flow control to be set (None, RS/CS, XON/XOFF) by pressing Flow Control touch switch.

Display presence or absence of the response by pressing the Response touch switch.

The setting option changes each time the touch switch is pressed.

In this example, serial port A is used.

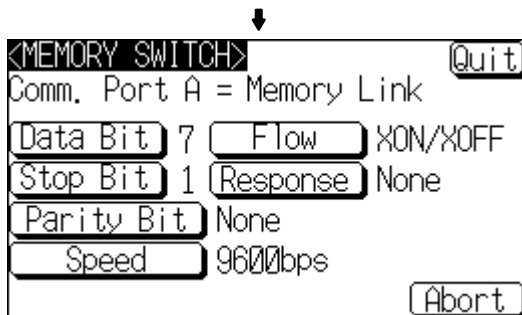

Press the Quit touch switch.

- To quit the baud rate setting screen without setting the baud rate, press the Abort touch switch. The NT21 returns to the memory switch setting screen (4/4) and the previous baud rate remains in effect.

On completion of baud rate setting, the NT21 returns to the memory switch setting screen (4/4).

To set other memory switches, select the relevant screen using the [↓] (next screen) or [↑] (previous screen) touch switch, then make the setting.

- To confirm the settings and quit the memory switch setting screen, press the Quit touch switch. The settings made last will be set and the NT21 will return to the MAINTENANCE MODE MENU screen.

If the combination of settings for serial port A and serial port B is not allowed, an error message (indicating that the protocol settings are incorrect) will be displayed when the Quit touch switch is pressed. In this case, correct the settings to a combination that is allowed.

- To quit the memory switch setting screen without confirming the settings, press the Abort touch switch. The NT21 will return to the MAINTENANCE MODE MENU screen with the previous settings still in effect.

## 6-8 Starting Operation

After completing screen data transmission and setting the communication conditions, connect the NT21 to the host and start operation.

- Note** Check the operation of all screen data and host programs carefully before using them. If incorrect, the system may operate unpredictably.

### Switching to the RUN Mode and Starting Operation

Press the Quit touch switch on the System Menu screen or other screen. The NT21 switches to the RUN mode and starts operation.



The operation at the start is as follows.

#### **Display of the System Initialization Screen**

When establishing the communication with a host, the System initializing character string is displayed on the screen. If the communication with the host cannot be established, the System initializing screen remains up. If this is the case, check the settings at the host and the PT side, the cables and wiring.

In addition, creating screen number 9000 enables the display of a screen other than the System initialization screen.

#### **Transmission of the Contents of Memory Tables**

If the Resume Function memory switch is set to ON, or if the initial values of the memory tables are used, the contents of the numeral/character-string memory tables are copied to the allocated words at the host.

↓

#### **Display of the Startup Screen**

The startup screen is displayed on reading the contents (screen number of the screen to be displayed) of the first word of the PT Status Control Area.

If the contents are not correct for a screen number, or there is no data registered for the set screen number, an error message is displayed.

### **Checking Communications between the NT21 and the Host**

Execute the host program and confirm that the following operations are performed normally.

- Confirm that the NT21 screens switch in accordance with the host program.

If the screens do not switch correctly, check the connection between the host and the NT21, and also check if the hardware settings are correct. For details, refer to *Section 4 Connecting to the Host from the RS-232C Port*, or *Section 5 Connecting to the Host from the RS-422A/485 Port*.

- Confirm that the operation results of touch switch and numeric value/character string input at the NT21 are sent to the host correctly by displaying the contents of the host words and bits using a Programming Device (e.g., CX-Programmer).

If the results of operations at the NT21 are not sent to the host correctly, check the setting of the display elements. For details on setting display elements, refer to the description of each display element in the *Reference Manual*.

## **6-9 System Settings**

The NT21 supports a variety of functions that are convenient during operation to be set with memory switches. This section describes the memory switch settings relating to the operation environment.

Since the memory switch settings are backed up to the flash memory by the battery in the NT21, they are not cleared when the power is switched OFF.

### **6-9-1 Memory Switch Setting Screens**

There are four memory switch setting screens. The required screen can be displayed by using the [↓] (next screen) and [↑] (previous screen) touch switches.

The following diagrams show how to display the memory switch setting screens and move between the screens.

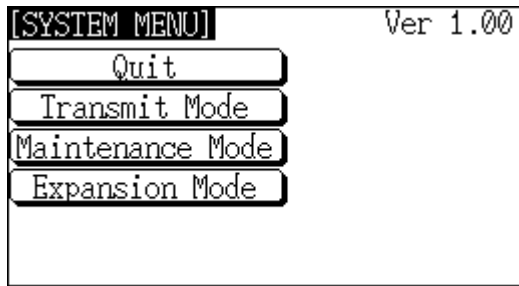

Select Maintenance Mode.

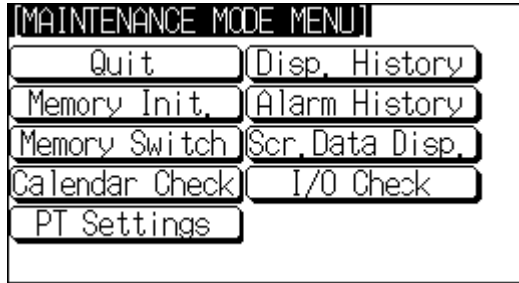

Select Memory Switch.

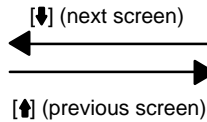
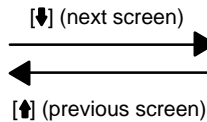
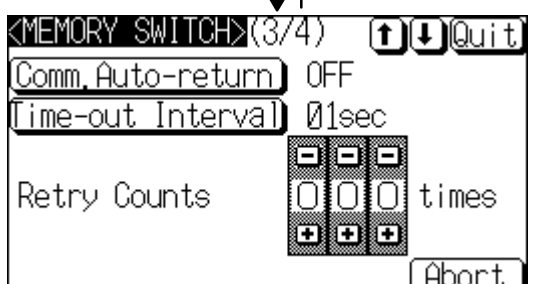
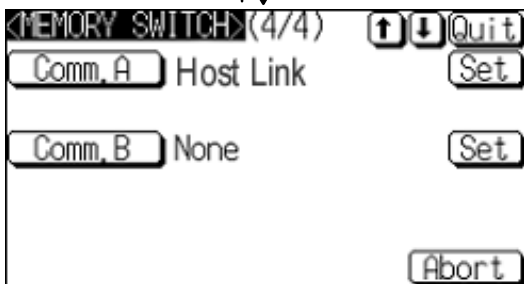
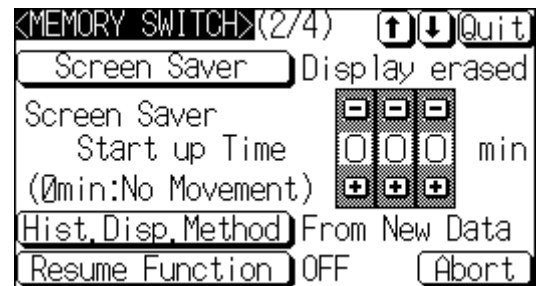
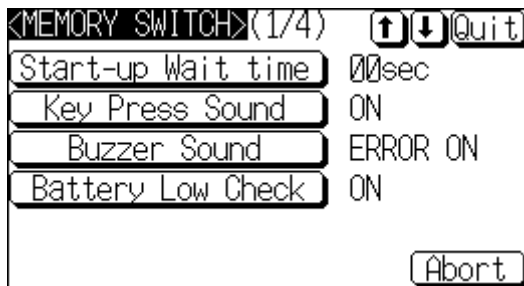

**Memory Switch Settings**

A list of the memory switch settings is presented below.

- Start-up Wait Time page 136
- Key Press Sound page 136
- Buzzer Sound page 137
- Battery Check page 137
- Screen Saver Movement page 138
- Screen Saver Startup Time page 138
- Hist. Disp. Method page 139
- Resume Function page 140

- Comm. Auto-return page 141
- Time-out Interval page 142
- Retry Counts page 142
- Comm. A Method page 125  
(For the bar code reader, refer to page 144.)
- Comm. B Method page 125

For details on each setting, refer to the pages indicated.

### 6-9-2 Setting the Start-up Wait Time

The Start-up Wait Time is the time lapse until the NT21 switches to the RUN mode after it has been turned ON. Set this item if it takes some time for the host to start operation. Nothing is displayed during the Start-up Wait Time.

The setting range is 0 to 10 seconds. The default (factory) setting is 00sec.

Set the system start-up wait time with the first Memory Switch Setting Screen (1/4) as shown below. (Refer to 6-9-1 Memory Switch Setting Screens for details on displaying the Screen.)

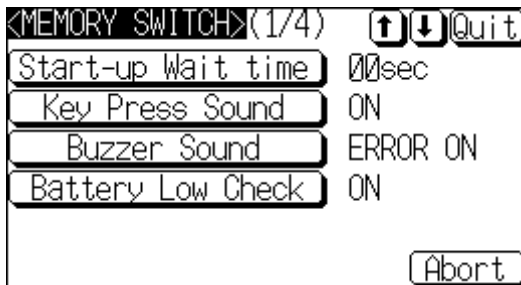

Press Start-up Wait Time to display the required time lapse.

The setting option changes each time the touch switch is pressed, according to the following sequence.

01 02 03 .... 09 10 00 01 ....

To set other memory switches, select the relevant screen using the [↓] (next screen) or [↑] (previous screen) touch switch, then make the setting.

- To confirm the settings and quit the memory switch setting screen, press the Quit touch switch. The settings made last will be set and the NT21 will return to the MAINTENANCE MODE MENU screen.
- To quit the memory switch setting screen without confirming the settings, press the Abort touch switch. The NT21 will return to the MAINTENANCE MODE MENU screen with the previous settings still in effect.

### 6-9-3 Setting the Key Press Sound

It is possible to set whether or not the key sound is sounded when a touch switch on the NT21 screen is pressed.

- ON: When a touch switch is pressed, the key sound sounds for 0.2 seconds.
- OFF: The key sound does not sound when touch switches are pressed.

The default (factory) setting is ON.

Turn the key-press sound ON and OFF with the first Memory Switch Setting Screen (1/4) as shown below. (Refer to 6-9-1 Memory Switch Setting Screens for details on displaying the Screen.)

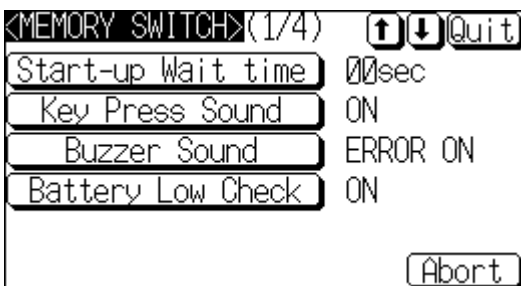

Press Key Press Sound to display ON or OFF.

The setting option changes each time the touch switch is pressed.

To set other memory switches, select the relevant screen using the [↓] (next screen) or [↑] (previous screen) touch switch, then make the setting.

- To confirm the settings and quit the memory switch setting screen, press the Quit touch switch. The settings made last will be set and the NT21 will return to the MAINTENANCE MODE MENU screen.
- To quit the memory switch setting screen without confirming the settings, press the Abort touch switch. The NT21 will return to the MAINTENANCE MODE MENU screen with the previous settings still in effect.

## 6-9-4 Setting the Buzzer Sound

The NT21 has a function for sounding a buzzer in response to a command from the host, or when an error occurs. It is possible to set whether or not the buzzer actually sounds with the memory switches.

- ON:  
The buzzer sounds in response to commands and when an error occurs.
  - OFF:  
The buzzer does not sound in response to commands or when errors occur.
  - ERROR ON:  
The buzzer sounds only when an error occurs.
- The default (factory) setting is OFF.

### Reference:

- There are other commands and settings relating to the buzzer, but this memory switch setting has the highest priority.
- For details on the buzzer, refer to 2-15-5 *Buzzer Function* in the *Reference Manual*.

Set the buzzer sound with the first Memory Switch Setting Screen (1/4) as shown below. (Refer to 6-9-1 *Memory Switch Setting Screens* for details on displaying the Screen.)

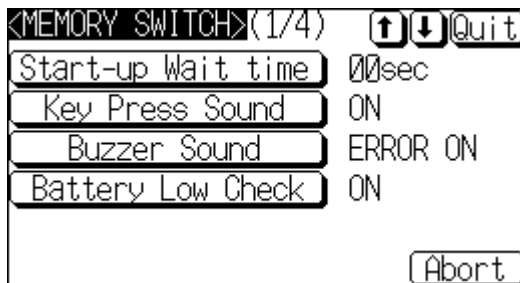

Press Buzzer Sound to display ON, OFF, or ERROR ON.

The setting option changes each time the touch switch is pressed.

To set other memory switches, select the relevant screen using the [↓] (next screen) or [↑] (previous screen) touch switch, then make the setting.

- To confirm the settings and quit the memory switch setting screen, press the Quit touch switch. The settings made last will be set and the NT21 will return to the MAINTENANCE MODE MENU screen.
- To quit the memory switch setting screen without confirming the settings, press the Abort touch switch. The NT21 will return to the MAINTENANCE MODE MENU screen with the previous settings still in effect.

## 6-9-5 Setting a Battery Check

An optional Battery can be connected to the NT21 to back up memory table contents, screen display/alarm history data, recipe data, and other data when power is turned OFF. When a Battery is connected, always turn ON the "Battery Low Check" memory switch.

- ON: Battery checked.
- OFF: Battery not checked.

The default setting is OFF.

- 
- Reference:**
- The Battery is optional for the NT21 and is sold separate. No Battery is installed at the factory.
  - Do not turn ON the the “Battery Low Check” memory switch when a Battery is not installed. The battery low indicator will remain ON constantly.
  - Bit 13 (Battery Status) in the PT Status Notify Bits in the PT Status Notify Area will turn ON when the Battery voltage drops.
  - The status of the Battery can also be checked by selecting “Battery” from the Device Check menu. This item can be used to check the status of the Battery regardless of the setting of the “Battery Low Check” memory switch.
- 

To set other memory switches, select the relevant screen using the [↓] (next screen) or [↑] (previous screen) touch switch, then make the setting.

- To confirm the settings and quit the memory switch setting screen, press the Quit touch switch. The settings made last will be set and the NT21 will return to the MAINTENANCE MODE MENU screen.
- To quit the memory switch setting screen without confirming the settings, press the Abort touch switch. The NT21 will return to the MAINTENANCE MODE MENU screen with the previous settings still in effect.

## 6-9-6 Setting the Screen Saver Timer

The NT21 has a screen saver function to extend the life of the backlight and protect the LCD screen from screen-burn by having an image displayed too long. If no operations are performed after a set time, the screen display will be turned OFF automatically and a character string will be displayed at random positions on the screen.

The Screen Saver Movement setting determines whether or not the character string will be displayed while the screen display is OFF.

- If Display is selected, the character string stored in character string memory table entry number 0 will be displayed, and the backlight status will not change.
- If Display erase is selected, the character string will not be displayed, and the backlight status will turn OFF.

The default (factory) setting is Display erase.

The Screen Saver Start up Time setting determines the time interval before the screen saver function operates.

The setting range is 0 to 255 minutes. The default (factory) setting is 10 minutes. If 000 is set, the screen saver function does not operate.

The screen saver can be canceled, and former screen redisplayed, by any of the following operations.

- Touching any part of the touch panel
- Screen switching due to PT Status Control Area operations
- Screen switching due to bit memory table operations
- Execution of any of the following PT status control bit operations:
  - Changing the backlight mode
  - Screen display (change from OFF to ON)

- 
- Reference:** The screen saver function operates only when the NT21 is in RUN mode. The screen saver function will not start in System Menu or System Installer mode.
-

Set the screen saver operation with the second Memory Switch Setting Screen (2/4) as shown below. (Refer to 6-9-1 Memory Switch Setting Screens for details on displaying the Screen.)

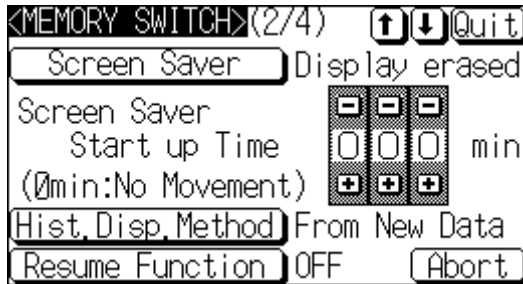

Press Screen Saver Movement to display Display or Display erased.

The setting option changes each time the touch switch is pressed.

Set a time in the input field to the right of Screen Saver Start up Time.

Each of the digits can be incremented or decremented by pressing the associated + and – keys.

To set other memory switches, select the relevant screen using the [↓] (next screen) or [↑] (previous screen) touch switch, then make the setting.

- To confirm the settings and quit the memory switch setting screen, press the Quit touch switch. The settings made last will be set and the NT21 will return to the MAINTENANCE MODE MENU screen.
- To quit the memory switch setting screen without confirming the settings, press the Abort touch switch. The NT21 will return to the MAINTENANCE MODE MENU screen with the previous settings still in effect.

### 6-9-7 Setting the History Display Method

The NT21 features the display history record function, which records the time at which screens are displayed during operation and the number of times they are displayed, and the alarm history record function, which continually monitors bit statuses at the host and records the time when bits come ON and the number of times they come ON.

The Hist. Disp. Method setting determines whether — when these record data are displayed in sort by occurrence — the records are displayed in a progression from newest to oldest or from oldest to newest.

- From Old Data:  
The records are displayed in sequence from the oldest to newest.
- From New Data:  
The records are displayed in sequence from the newest to oldest.

The default (factory) setting is From New Data.

- 
- Reference:**
- Install an optional battery in the NT21 when using the display history record function or the alarm history record function.
  - If a battery is installed, the contents of the history record will be retained even when the NT21 is turned OFF, but the data will be lost if the battery fails and the NT21 is turned OFF.
  - For details on the display history record function and the alarm history record function, refer to 2-15-1 Display History Record Function and 2-15-2 Alarm History Record Function in the Reference Manual.
-

Set the history display method with the second Memory Switch Setting Screen (2/4) as shown below. (Refer to 6-9-1 Memory Switch Setting Screens for details on displaying the Screen.)

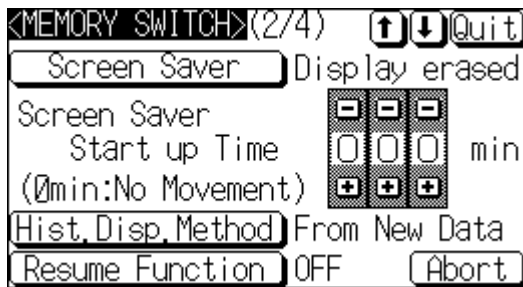

Press Hist. Disp. Method to display the required display order.

The setting option changes each time the touch switch is pressed.

To set other memory switches, select the relevant screen using the [↓] (next screen) or [↑] (previous screen) touch switch, then make the setting.

- To confirm the settings and quit the memory switch setting screen, press the Quit touch switch. The settings made last will be set and the NT21 will return to the MAINTENANCE MODE MENU screen.
- To quit the memory switch setting screen without confirming the settings, press the Abort touch switch. The NT21 will return to the MAINTENANCE MODE MENU screen with the previous settings still in effect.

### 6-9-8 Setting the Resume Function (Battery Required)

The NT21 has a function to retain the contents of the memory tables even when the power to the NT21 is OFF and write back them to the host when the power is turned ON. The optional battery must be installed to use the resume function.

If the resume function is OFF, the memory tables are initialized to these initial values on switching to the RUN mode. If the resume function is ON, these are not initialized and are kept the battery-backed up contents.

When the memory table is initialized, its contents are reset to the initial state that is set by the NT Support Tool.

When the system is started up the next time, the screen is displayed using the previous contents of the memory table.

- ON: The resume function is used.
- OFF: The resume function is not used.

The default (factory) setting is OFF.

- 
- Reference:**
- The resume function is effective only when a battery is installed in the NT21. Install an optional battery if you plan to use the resume function.
  - If the battery fails, the memory table contents will be initialized even if the resume function is set to ON.
  - For details on the resume record function, refer to 2-15-3 Resume Function in the Reference Manual.
-

Set the resume function with the second Memory Switch Setting Screen (2/4) as shown below. (Refer to *6-9-1 Memory Switch Setting Screens* for details on displaying the Screen.)

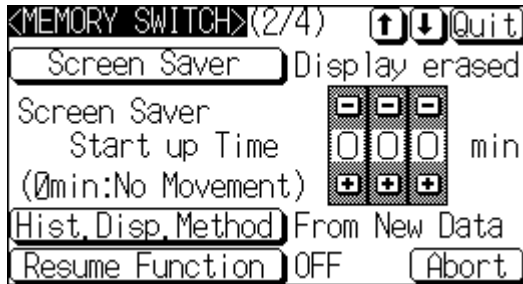

Press Resume Function to display the required setting.

The setting option changes each time the touch switch is pressed.

To set other memory switches, select the relevant screen using the [↓] (next screen) or [↑] (previous screen) touch switch, then make the setting.

- To confirm the settings and quit the memory switch setting screen, press the Quit touch switch. The settings made last will be set and the NT21 will return to the MAINTENANCE MODE MENU screen.
- To quit the memory switch setting screen without confirming the settings, press the Abort touch switch. The NT21 will return to the MAINTENANCE MODE MENU screen with the previous settings still in effect.

## 6-9-9 Setting the Automatic Reset Function

The NT21 has a function for ignoring communication errors and automatically returning to the RUN mode when they occur.

The Comm. Auto-return setting determines whether the automatic reset function is effective or not.

- ON:  
When a communication error occurs, the NT21 automatically returns to the RUN mode without displaying an error screen (the System Initializing screen may be displayed).
- OFF:  
When a communication error occurs, an error screen is displayed and operation stops. Pressing OK on the error screen returns the NT21 to the RUN mode.

The default (factory) setting is OFF.

- 
- Reference:**
- If a communication error occurs when OFF is set for Comm. Auto-return, the NT21 makes the number of attempts at communication with the host specified by the setting for the Retry Counts touch switch (page 142). If communication cannot be re-established in any of these attempts, an error screen is displayed.
  - For details on communication errors, refer to *7-2-5 Communication Errors and Their Remedies* (page 181).
-



Set the automatic reset function with the third Memory Switch Setting Screen (3/4) as shown below. (Refer to 6-9-1 Memory Switch Setting Screens for details on displaying the Screen.)

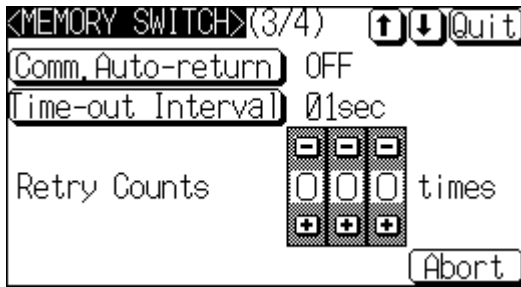

Press Comm. Auto-return to display the required setting.

The setting option changes each time the touch switch is pressed.

To set other memory switches, select the relevant screen using the [↓] (next screen) or [↑] (previous screen) touch switch, then make the setting.

- To confirm the settings and quit the memory switch setting screen, press the Quit touch switch. The settings made last will be set and the NT21 will return to the MAINTENANCE MODE MENU screen.
- To quit the memory switch setting screen without confirming the settings, press the Abort touch switch. The NT21 will return to the MAINTENANCE MODE MENU screen with the previous settings still in effect.

### 6-9-10 Setting the Time-out Interval

The NT21 goes into the time-out error status if no response is received from the host within a fixed time. The Time-out Interval setting specifies the time lapse at which time-out is judged to have occurred.

The setting range is 0 to 10 seconds. The default (factory) setting is 1 second.

**Reference:** Whether or not an error screen is displayed when a time-out error occurs is determined by the setting for the Comm. Auto-return memory switch.

Set the time-out interval with the third Memory Switch Setting Screen (3/4) as shown below. (Refer to 6-9-1 Memory Switch Setting Screens for details on displaying the Screen.)

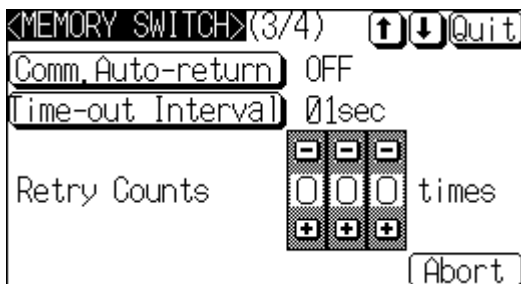

Press Time-out Interval to display the required time lapse.

The setting option changes each time the touch switch is pressed, according to the following sequence.

01 02 03 ... 09 10 00 01 ...

To set other memory switches, select the relevant screen using the [↓] (next screen) or [↑] (previous screen) touch switch, then make the setting.

- To confirm the settings and quit the memory switch setting screen, press the Quit touch switch. The settings made last will be set and the NT21 will return to the MAINTENANCE MODE MENU screen.
- To quit the memory switch setting screen without confirming the settings, press the Abort touch switch. The NT21 will return to the MAINTENANCE MODE MENU screen with the previous settings still in effect.

### 6-9-11 Setting the Retry Count

The NT21 does not immediately display an error screen when a communication error occurs, but tries to re-establish communication. The Retry Counts setting

specifies the number of attempts to be made to re-establish communication. If communication cannot be recovered within this number of attempts, the following happens depending on the setting made for the Comm. Auto-return memory switch (page 141).

- Comm. Auto-return ON:

Operation in the RUN mode is continued without displaying an error screen. Regardless of the setting made for Retry Counts, attempts to re-establish communication are repeated until normal communication is achieved.

- Comm. Auto-return OFF:

The RUN mode is ended and an error screen is displayed. On pressing the OK touch switch on the error screen, the screen displayed immediately before is redisplayed and attempts are made to re-establish communication.

The System Menu can be displayed from the error screen by pressing any two of the four corners of the touch panel simultaneously.

The setting range is 0 to 255 times. The default (factory) setting is 5 times.

**Reference:** For details on communication errors, refer to *7-2-5 Communication Errors and Their Remedies* (page 181).

Set the retry count with the third Memory Switch Setting Screen (3/4) as shown below. (Refer to *6-9-12 Memory Switch Setting Screens* for details on displaying the Screen.)

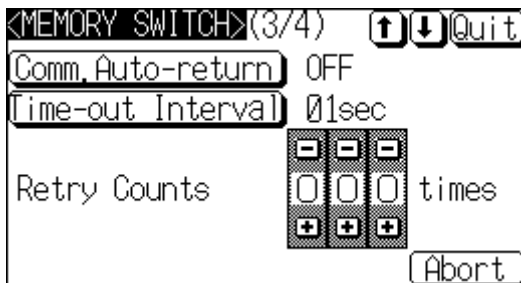

Set a number of times in the input field to the right of Retry Counts.

Each of the digits can be incremented or decremented by pressing the associated + and – keys.

To set other memory switches, select the relevant screen using the [↓] (next screen) or [↑] (previous screen) touch switch, then make the setting.

- To confirm the settings and quit the memory switch setting screen, press the Quit touch switch. The settings made last will be set and the NT21 will return to the MAINTENANCE MODE MENU screen.
- To quit the memory switch setting screen without confirming the settings, press the Abort touch switch. The NT21 will return to the MAINTENANCE MODE MENU screen with the previous settings still in effect.

## 6-10 Setting the Bar Code Reader Input Function

The NT21 has a bar code reader input function, which allows a bar code reader to be connected and bar code data to read as character strings into character string input fields.

This section describes the communication conditions for the bar code reader and the setting method for confirming the input data.

- Reference:**
- For details on bar code reader types and connection methods, refer to 3-4 *Connecting a Bar Code Reader* in this manual and for details on how to use a bar code reader refer to 3-7 *Input of Numeric Values and Character Strings* in the *Reference Manual*.
  - The bar code reader is connected to serial port A. This means that serial port B must be used for communications with the host.

### Communication Condition Settings for Bar Code Readers

Setting Item	Function	Setting Options	Page
Data bits	Sets the bit length for the data bits.	7* or 8 bits	Page 145
Stop bits	Sets the stop bit length for the data.	1 or 2* bits	Page 145
Parity bit	Sets the parity bit for the data.	None, odd, even*	Page 145
Baud rate	Sets the baud rate for the bar code reader	4800, 9600*, or 19200 bps	Page 145
Input method	Sets the method for confirming data when it is input to a character string input field. Manual: The data is confirmed with a touch switch. The data can be corrected and character strings can be added. Auto: The data is automatically confirmed when it is input.	Manual*, Auto	Page 145

\* Default (factory) setting

### Setting the Communication Conditions and Setting Method

Set the bar code reader communication conditions and method of confirmation at input by following the menu operation from the System Menu shown below.

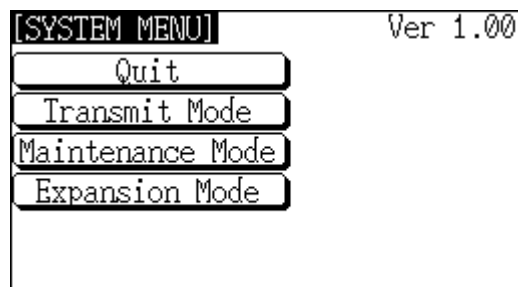

Select Maintenance Mode.

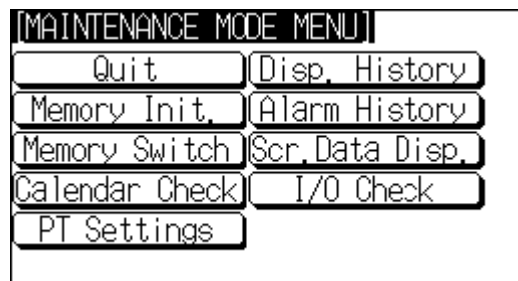

Select Memory Switch.

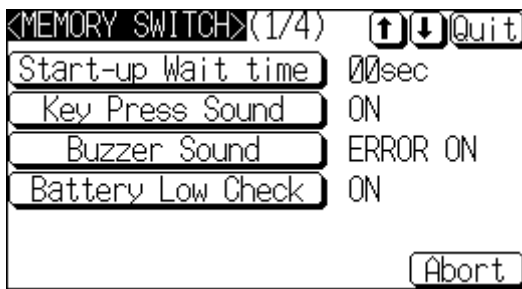

Press [↓] (next screen) or [↑] (previous screen) to display the fourth memory switch setting screen.

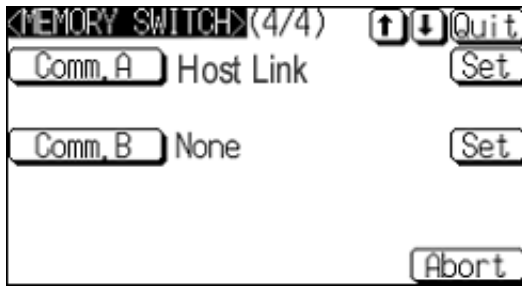

Press Comm. A Method to select Bar-Code Reader.

The setting option changes each time the touch switch is pressed.

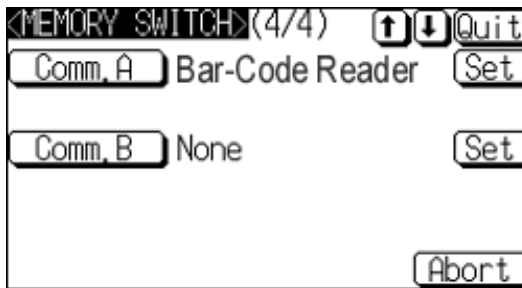

Press the Set touch switch to the right of Comm. A Method.

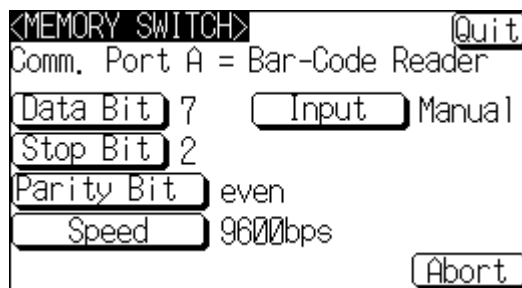

Display the required setting for each item by pressing the touch switches.

The setting option changes each time the touch switch is pressed.

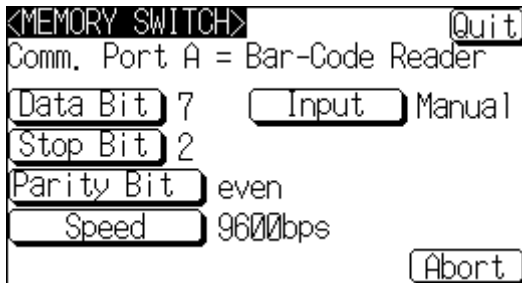

Press Quit.

Pressing Abort on the communication condition/confirmation method setting screen causes the NT21 to return to the memory switch setting screen (4/4) without executing setting (with the previous settings still effective).

On completion of communication condition/confirmation method setting, the NT21 returns to the memory switch setting screen (4/4).

To set other memory switches, select the relevant screen using the [↓] (next screen) or [↑] (previous screen) touch switch, then make the setting.

- To confirm the settings and quit the memory switch setting screen, press the Quit touch switch. The settings made last will be set and the NT21 will return to the MAINTENANCE MODE MENU screen.
- To quit the memory switch setting screen without confirming the settings, press the Abort touch switch. The NT21 will return to the MAINTENANCE MODE MENU screen with the previous settings still in effect.

## 6-11 System Maintenance

The NT21 has the following maintenance and check functions.

Item		Function	Page
Calendar Check		Displays the last time data read from the host.	Page 147
PT Settings		Direct connection setting of the screen data in the NT21 and displays of the setting statuses of the serial ports.	Page 149
Display history record		Displays display history record data.	Page 150
Alarm history record		Displays alarm history record data.	Page 151
Screen data check		Displays of each screen stored in the NT21.	Page 153
I/O check	Device check	Checks the I/O functions of the NT21.	Page 156
	I/F check	Checks the communication functions of the NT21.	Page 161

This section describes how to use these functions.

### 6-11-1 Displaying/Setting the Calendar and Clock

The NT21 has a clock function that displays the date and time.

When the NT21 is in RUN mode, it regularly reads the clock data from the specified area in the host and stores that data in numeral memory table entries 247 to 253. The "Calendar Check" displays the most recent clock data read from the host.

- 
- Reference:**
- The NT21's clock function is not a counter. This function just displays the most recent clock data read from the host.
  - The clock data is initialized to the default settings when the NT21 is turned OFF. The default date and time is 01/01/00 00:00:00. (The clock data is not backed up even if a battery is installed.)
  - After the NT21 is turned ON, the default date and time (01/01/00 00:00:00) will be displayed until communications are established with the host and the clock data is read properly from the host.
  - The clock function does not strictly check the date and day of the week settings.
  - The clock data cannot be set from the NT21's System Menu or the NT Support Tool.
  - Numeral memory table entries 247 to 253 are reserved for the clock function (read-only). Clock data can be read from these addresses in the numeral memory table during operation and displayed.
-

Display clock data by following the menu operations from the System Menu as shown below.

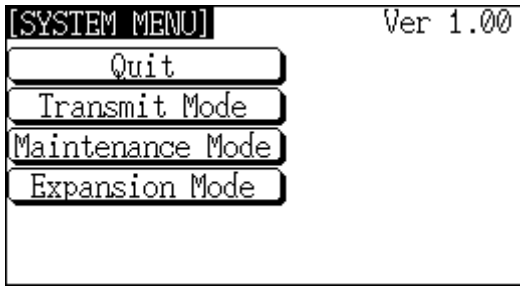

Select Maintenance Mode.

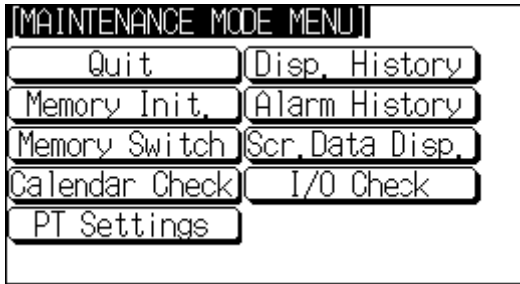

Select Calendar Check.

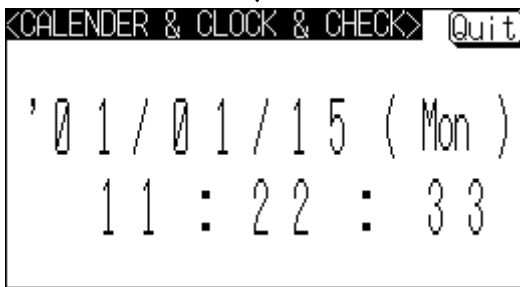

Press Quit

The NT21 will return to the MAINTENANCE MODE MENU screen.

### 6-11-2 Checking the PT Setting Status

The direct connection settings of the NT21 screen data, and the settings for serial port A and serial port B, can be checked.

#### Screen Configuration and Display Contents

There are four different screens that show the PT setting status. Select the Down Arrow or Up Arrow as shown below to go to the next or to the previous screen. The display methods and contents are shown below.

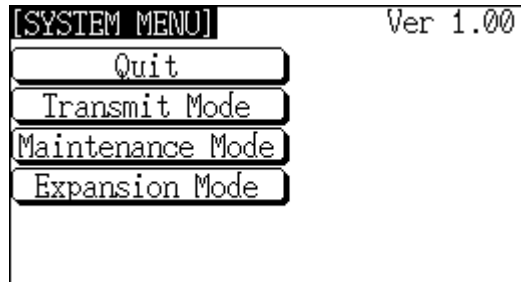

Select Maintenance Mode.

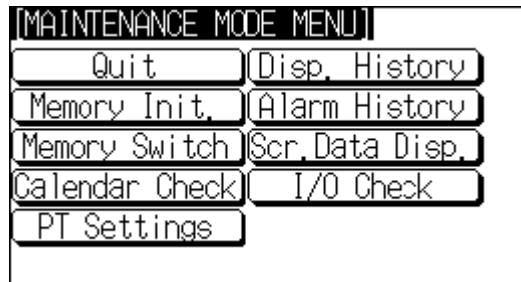

Select PT Settings.

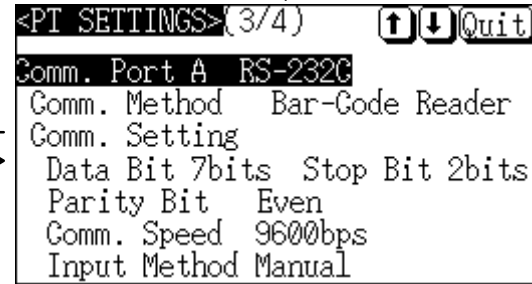
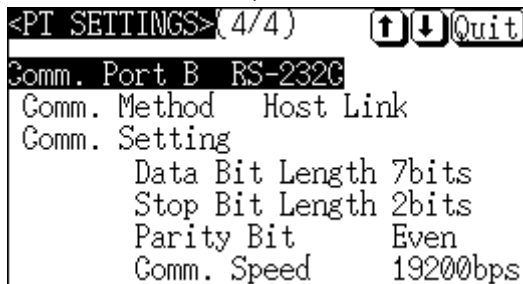
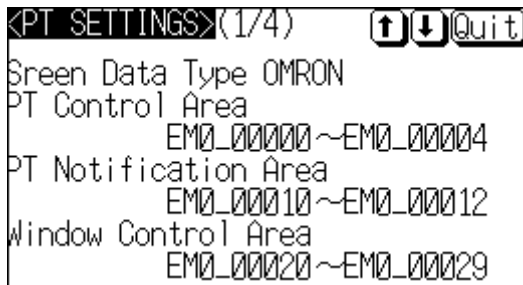

(next screen) [↓] [↑] (previous screen)

(next screen) [↓] [↑] (previous screen)

[↓] (next screen)  
[↑] (previous screen)

[↓] (next screen)  
[↑] (previous screen)

The Maintenance Mode Menu will be returned to when **Quit** is selected.

#### Display Contents of the First Screen

Item	Meaning
Screen Data Type	The host type set for the screen data
PT Control Area	Word at the host to which the PT Status Control Area is allocated



Item	Meaning
PT Notification Area	Word at the host to which the PT Status Notify Area is allocated
Window Control Area	Word at the host to which the Window Control Area is allocated

#### Display Contents of the Second Screen

Item	Meaning
Numeric Expression	Default for the method of interpretation of the contents of host words to which numeral memory table entries are allocated (numeric value storage method).
Expansion I/F	Type of Unit installed at the expansion interface connector
Compatibility	Sets whether or not to use NT20S compatible mode for screen data. (Sets whether to operate as a normal NT21 or emulate many key NT20S characteristics.)

#### Display Contents of the Third Screen

Item	Meaning
Comm. Port A	Communication type set for serial port A (fixed as RS-232C)
Comm. Method	Communication method set for serial port A
Comm. Setting	Communication conditions set for serial port A (display contents differ according to the communication method)

#### Display Contents of the Fourth Screen

Item	Meaning
Comm. Port B	Communication type set for serial port B
Comm. Method	Communication method set for serial port B
Comm. Setting	Communication settings set for serial port B (display contents differ according to the communication method)

### 6-11-3 Displaying the Display History Record

The display history record function is a function that records the order of display of each screen during operation, and the number of times each screen is displayed. Only the screens for which the display history screen attribute has been set in advance are processed by this function.

The record data can be displayed using an operation from the System Menu. This section explains how to display the display history record data recorded in the NT21.

Note that there are two display methods: sort by occurrence (display time order) and sort by frequency (order of number of times displayed).

- Reference:**
- Install an optional battery in the NT21 when using the display history record function.
  - When a battery is not installed or the battery fails, the contents of the history record will be unpredictable when the NT21 is turned OFF and will be initialized.
  - Time stamps will be recorded with the history records using clock data read by the NT21 from the host. If the clock data is incorrect, spaces will be stored instead of the data.
  - With the NT21, the record data can also be displayed by calling screen No. 9001 (sort by occurrence) or screen No. 9002 (sort by frequency) during the RUN mode.
  - For details on the display history record function, refer to *2-15-1 Display History Record Function* in the *Reference Manual*.

- The order of display for sort by occurrence display (from oldest record or from newest record) is set with the Hist. Disp. Method memory switch (page 139).

Display the display history record data by following the menu operations from the System Menu as shown below.

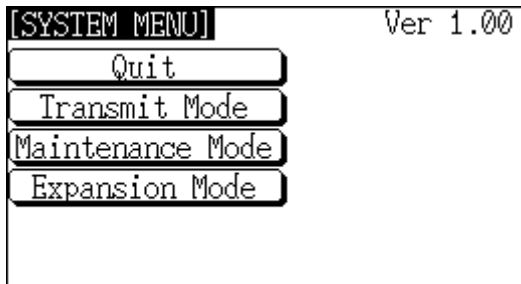

Select Maintenance Mode.

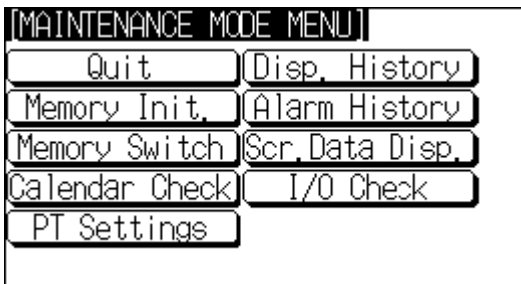

Select Display History.

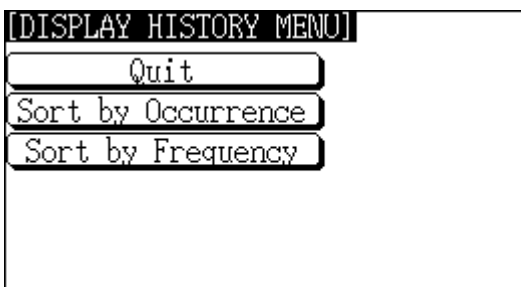

Select Sort by Occurrence or Sort by Frequency.

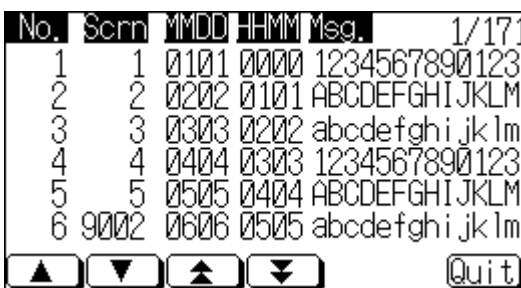

If necessary, select the next or previous screen by pressing [↓] (next screen) or [↑] (previous screen).

The example screen to the left shows a display for the sort by occurrence method (from oldest record).

Press Quit to return to the DISPLAY HISTORY MENU screen.

### 6-11-4 Displaying the Alarm History Record

The alarm history record function is a function that continually monitors during operation, the status of bits at the host designated in advance with bits in the bit memory table, and records the time when these bits come ON, and the number of times they come ON.

The record data can be displayed using an operation from the System Menu. This section explains how to display the alarm history record data recorded in the NT21.

Note that there are two display methods: sort by occurrence (ON time order) and sort by frequency (order of number of times the bits have come ON).

- 
- Reference:**
- Install an optional battery in the NT21 when using the alarm history record function.
  - When a battery is not installed or the battery fails, the contents of the history record will be unpredictable when the NT21 is turned OFF and will be initialized.
  - Time stamps will be recorded with the history records using the clock data read by the NT21 from the host. If the clock data is incorrect, spaces will be stored instead of the clock data.
  - With the NT21, the record data can also be displayed by registering an alarm history display element on the screen.
  - For details on the alarm history record function, refer to *2-15-2 Alarm History Record Function* in the *Reference Manual*.
  - The order of display for sort by occurrence display (from oldest record or from newest record) is set with the Hist. Disp. Method memory switch (page 139).
-

Display the alarm history record data by following the menu operations from the System Menu as shown below.

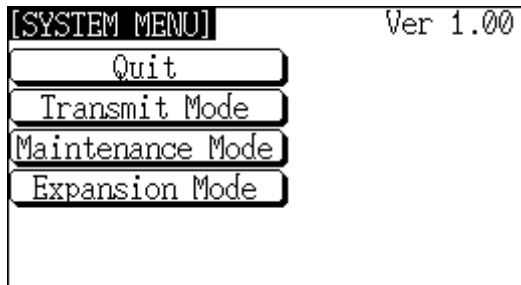

Select Maintenance Mode.

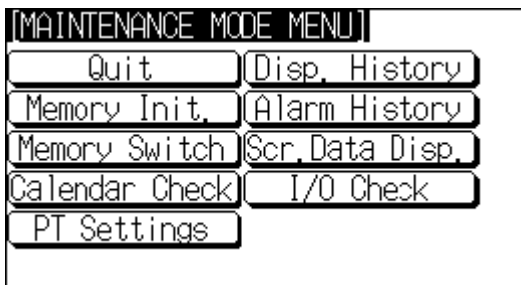

Select Alarm History.

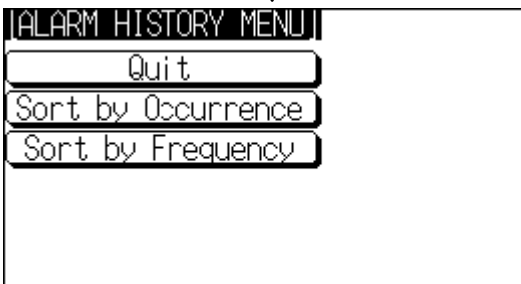

Select Sort by Occurrence or Sort by Frequency.

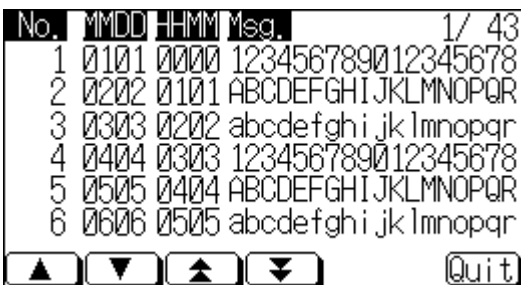

If necessary, select the next or previous screen by pressing [↓] (next screen) or [↑] (previous screen).

The example screen to the left shows a display for the sort by occurrence method (from oldest record).

Press Quit to return to the ALARM HISTORY MENU screen.

### 6-11-5 Checking Screen Data

The NT21 allows the registered screens (Nos. 1 to 3999) to be displayed and checked by operation from the System Menu.

- Reference:**
- Window screens cannot be displayed by operation from the System Menu.
  - Only the user screens (Nos. 1 to 3999) can be displayed. Screens for system use cannot be displayed.

**Specifying the Display Method**

Specify the display method for the screens as indicated in the table below.

Setting Item	Function	Setting Options
Display of Lamp/ Touch SW No.	Allows designation of whether the bit number of the lamp bit set for a lamp or touch switch is displayed or not. The display format is as follows L□○○○○○○○○ (□: area type, ○○○○○○○○: bit number).	ON, OFF*
Display of Memory Table Entry Num- ber	Allows designation of whether the table entry numbers in numeral and character string memory tables are displayed or not. The display format for the numeral memory table is N○○○○ and the display format for the character string memory table is S○○○○. This function is valid for the following display elements. - Numeral displays - Character string displays - Bar graphs - Numeral setting input fields (including thumbwheel type) - Character string input fields	ON, OFF*
Display of image/ Library No.	Allows designation of whether image/library code numbers are displayed or not.	ON, OFF*
Display of Broken Line Frame	Allows designation of whether or not broken line frames are displayed around the display elements for showing the positions registered.	ON, OFF*

\* Default (factory) setting

---

**Reference:** Each setting of the screen data check is effective only on this menu. Exiting from this screen data check menu resets the settings to the default (all the settings are set to OFF).

---

**Operations on the SCREEN DATA CHECK Screen**

The function shown below can be set on the SCREEN DATA CHECK screen.

Use this function as required when displaying complex screens on which multiple display elements have been registered overlapping each other.

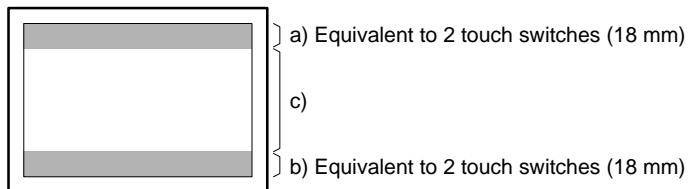

- a) Display the previous display element on the upper most portion of the screen in the order in which the display elements were registered (excluding fixed display elements).
- b) Display the next display element on the upper most portion of the screen in the order in which the display elements were registered (excluding fixed display elements).
- c) Return to the screen on which screens are specified.

**Displaying the SCREEN DATA CHECK Screen**

Display the SCREEN DATA CHECK screen by following the menu operation from the System Menu shown below.

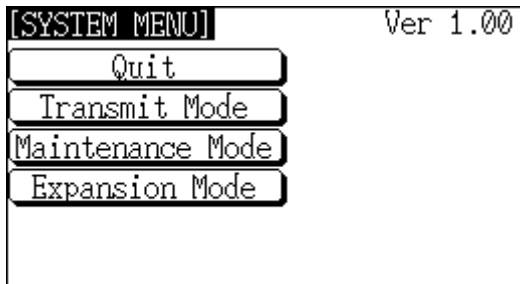

Select Maintenance Mode.

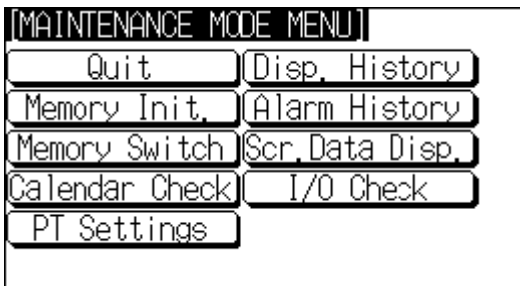

Select Screen Data Disp.

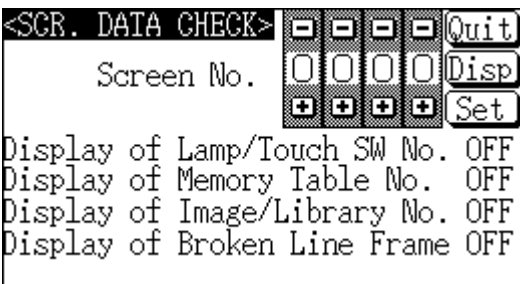

Use the numerical input switches to input the number of the screen to be displayed.

Each digit can be incremented or decremented by pressing the corresponding + and - keys.

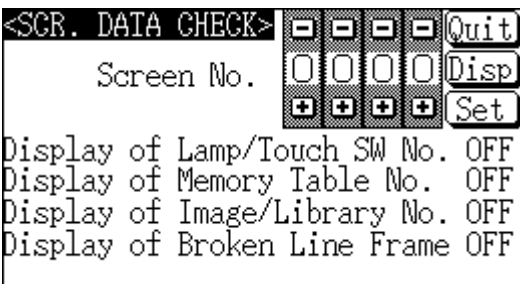

Press Set.

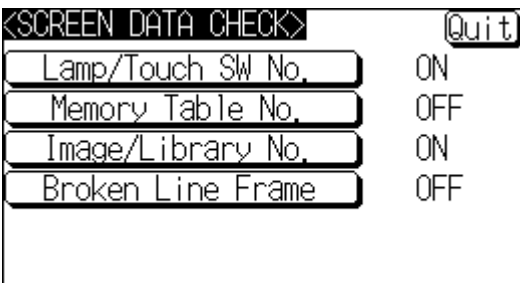

Press the touch switches to specify the display method in each case.

The setting option changes each time a touch switch is pressed.

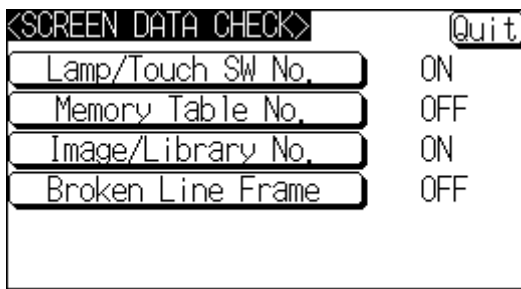

Press Quit to return to the screen number selection screen.

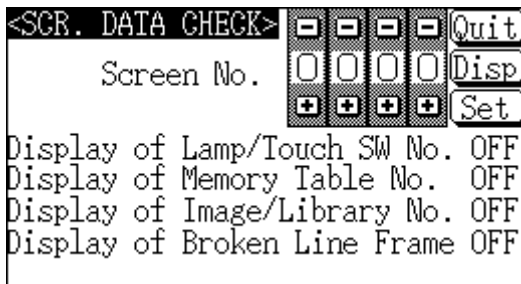

Press Disp.

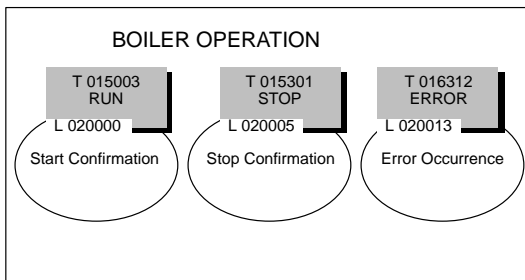

Touching the top or bottom of the screen changes the way the display elements overlap each other in the order in which they are registered.

In this example, the bottom portion of the touch switch, which is under the lamp, will be displayed over the lamp.

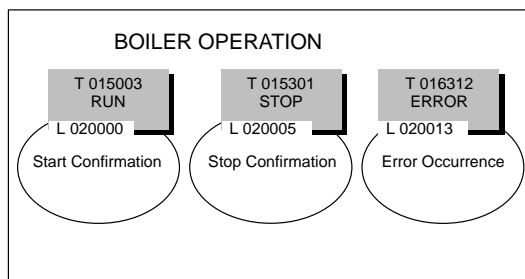

When you have finished checking the screen, press the center area of the screen to return to the SCREEN DATA CHECK screen.

If you wish to continue by checking another screen, repeat the operation, starting by specifying the screen number.

To end the operation, press Quit on the screen number selection screen. The NT21 returns to the MAINTENANCE MODE MENU screen.

### 6-11-6 Device Check

The NT21 provides checks on the functions of the following items.

- Buzzer Page 157
- LED Page 158
- LCD Page 158
- Backlight Page 158
- Screen data memory Page 159
- Touch switches Page 160
- Battery voltage Page 160

Display the Device Check Menu screen by following the menu operations from the System Menu as shown below.

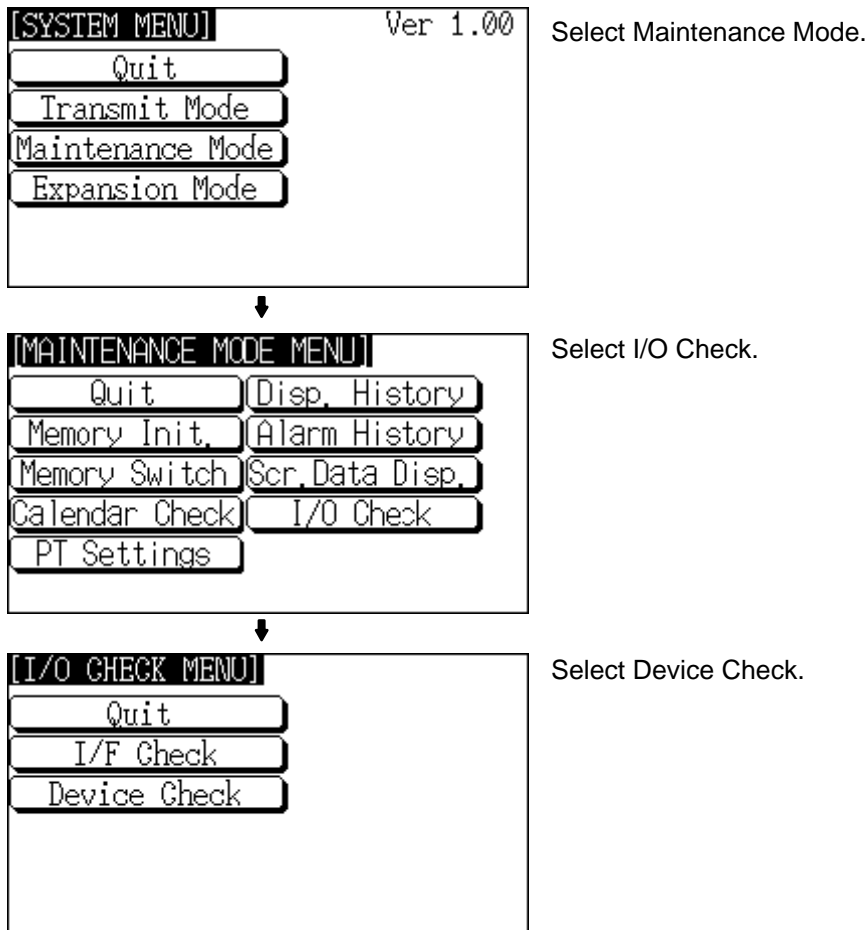

### Checking the Buzzer

Check if the buzzer sounds correctly.

**Reference:** The buzzer will sound in this check regardless of the setting made with the Buzzer Sound memory switch.

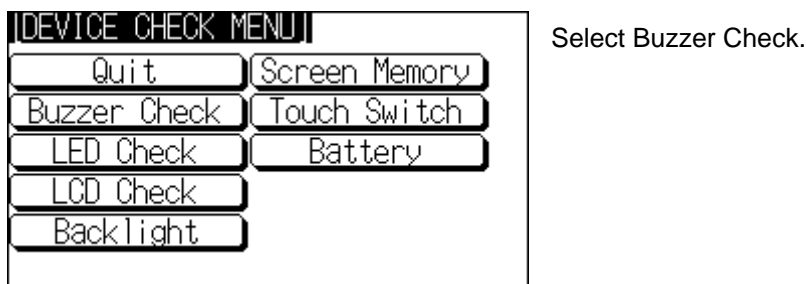

Check the buzzer by following the menu operations from the Device Check Menu as shown below.

- If the buzzer functions correctly, it will sound continuously. At this time, the Buzzer Check touch switch will be displayed in reverse video.
- To stop the buzzer while it is sounding, press the Buzzer Check touch switch again.



**Checking the RUN Indicator**

Check if the RUN Indicator lights normally.

Check the RUN Indicator by following the menu operations from the Device Check Menu as shown below.

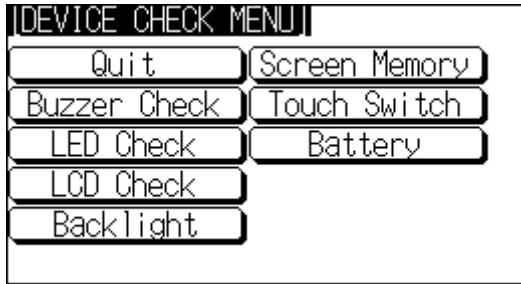

Select LED Check.

- If the RUN Indicator is functioning normally, it will operate as follows. At this time the LED Check touch switch will be displayed in reverse video.

Lit in green OFF lit in red OFF lit in green...

- To end the LED check, press the LED Check touch switch on the DEVICE CHECK MENU screen again.

**Checking the LCD (Screen Display)**

Check if the LCD (screen display) lights normally by following the menu operations from the System Menu as shown below.

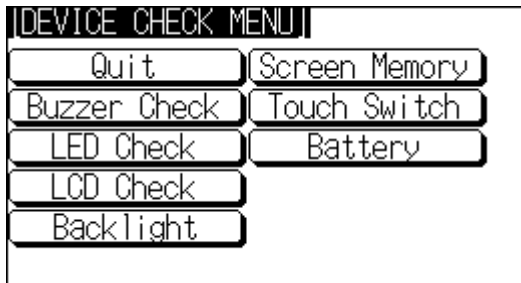

Select LCD Check.

- The check screen displays all the dots on the screen: either press anywhere on the touch panel or wait for three seconds and all the dots will be cleared.

On completion of the display and clearance of all dots, the NT21 returns to the DEVICE CHECK MENU screen.

- To abort the LCD check, press the top right corner of the touch panel. The NT21 will return to the DEVICE CHECK MENU screen.

**Checking the Backlight**

Check if the backlight lights normally by following the menu operations from the Device Check Menu as shown below.

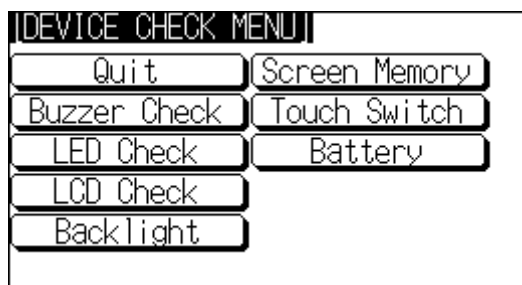

Select Backlight Check.

- If the backlight is normal, it flashes. At this time, the Backlight Check touch switch is displayed in reverse video.

- To end the backlight check, press the Backlight Check touch switch again.

**Screen Data Memory Check**

Check if the screen data memory is functioning normally.

- Reference:**
- In the screen data memory check, a write test is performed on the screen data memory. Since all the screen data in the NT21 is lost in this check, confirm that the data has been backed up at the NT Support Tool or Memory Unit before executing it.
  - If writing to the screen data memory is disabled by the setting for System Settings in the System Installer mode, it is not possible to execute a screen data check.
  - Once a screen data check has been started, it cannot be stopped.

Follow the menu operations from the Device Check Menu as shown below.

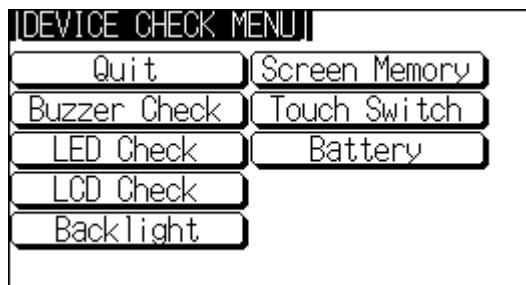

Select Screen Memory.



Press Execute.

- During the check, the message Checking Now... is displayed.
- On normal completion of the check, the message Memory Check OK is displayed.
- If an error is discovered in the check, the message Memory Check NG is displayed.

After confirming the result of the check, press Quit. The NT21 returns to the DEVICE CHECK MENU screen.

**Checking Touch Switches**

Check whether or not the touch switches function normally by following the menu operations from the Device Check Menu as shown below.

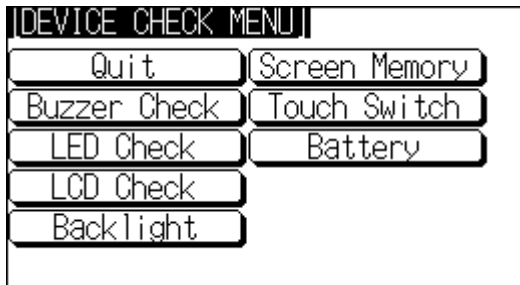

Select Touch Switch.

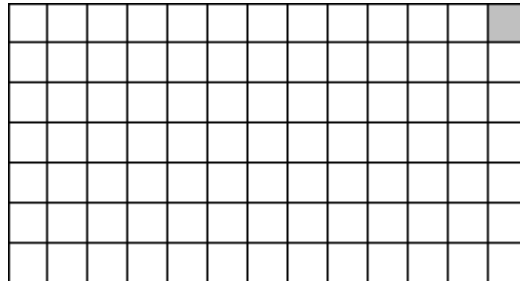

Press the touch switches displayed on the screen. A touch switch is normal if it is displayed in reverse video while pressed.

To end the check, press the touch switch at the top right corner, which is displayed in reverse video. The NT21 will return to the DEVICE CHECK MENU.

- Reference:**
- The functions of touch switches pressed during the I/O check are not notified to the host.
  - The check cannot be performed until the touch switch at the top right corner is displayed in reverse video. Start the check after the status of the touch switch at the top right corner has changed.

**Checking the Battery Voltage**

Check the voltage of the NT21's optional battery.

- Reference:** The NT21 will always detect low battery voltage if an optional battery is not installed.

Follow the menu operations from the Device Check Menu as shown below.

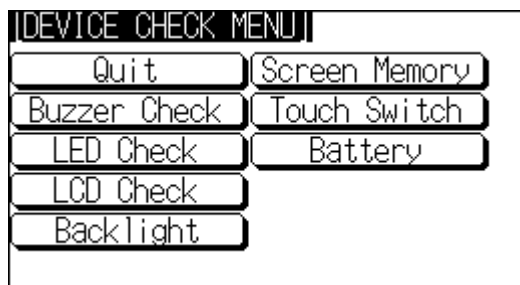

Select Battery.

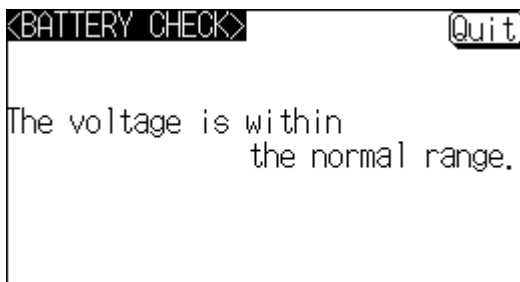

The results will indicate whether voltage is within the normal range or too low.

After confirming the result of the check, press Quit. The NT21 returns to the DEVICE CHECK MENU screen.

**Note** If a battery is installed and low battery voltage is detected, replace the battery immediately. For details on the replacement method, refer to *7-3-1 Replacing the Battery* (page 184).

### **6-11-7 Checking Interfaces**

The NT21 allows the following communication functions to be checked.

- Communication with the NT Support Tool      Page 161
- Communication at serial ports      Page 163

**Checking Communication with the NT Support Tool**

Check communication with the NT Support Tool by following the menu operation from the System Menu shown below.

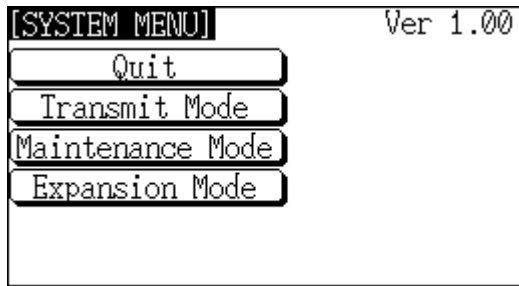

Select Maintenance Mode.

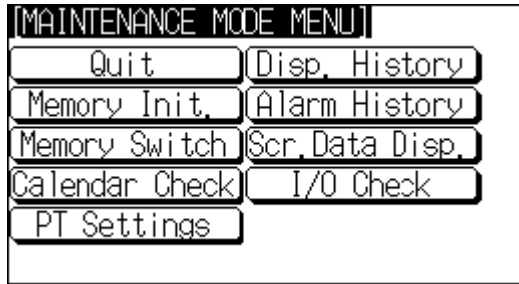

Select I/O Check.

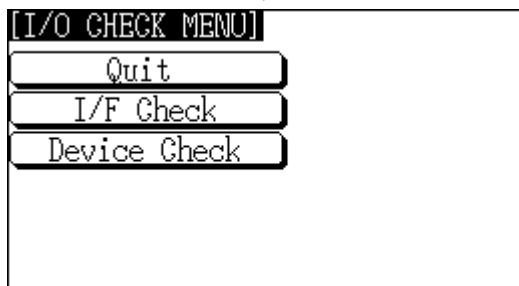

Select I/F Check.

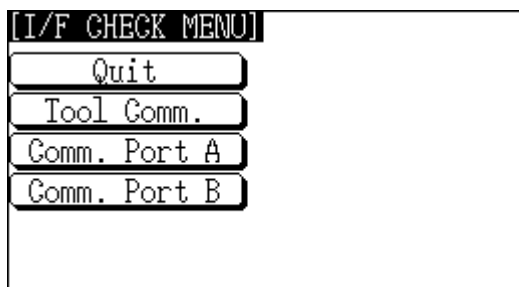

Select Tool Comm..

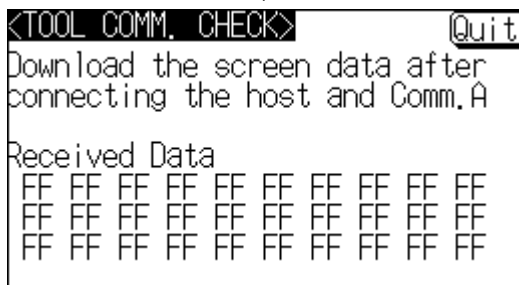

The check on communication with the NT Support Tool starts.

- If communication with the NT Support Tool is normal, data transmitted from the NT Support Tool is displayed as hexadecimal data when received by the NT21. After confirming the result of the test, press Quit. The NT21 returns to the I/F CHECK MENU screen.

## Checking Communication at Serial Ports

Check communication at the serial ports (A, B).

### Check Screen

The check screen and check method differ according to the communication method set for the port to be checked.

#### For Host Link

**Example:** Serial port A while using the host link

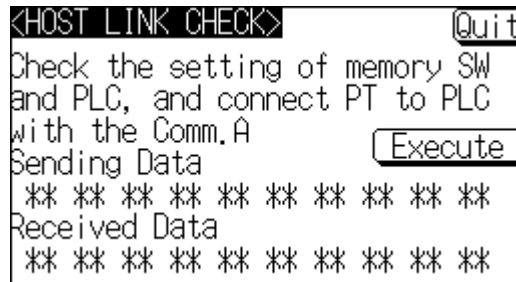

Press Execute to start the check. The data for checking communication is sent to the host, and is displayed as the Sending Data in hexadecimal.

- If communication with the host is normal, the reply from the host is displayed at Received Data in hexadecimal.
- If a communication error occurs while checking the communication conditions with the host, a communication error screen is displayed. Since this indicates that there is a communication fault, check the communication cables and settings.

#### For NT Link (1:1 or 1:N)

**Example:** Serial port B while using the 1:N NT Link

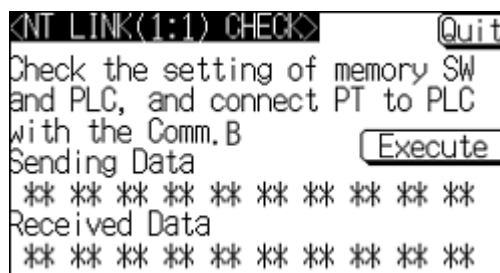

Press Execute to start the check. The data for checking communication is sent to the host, and is displayed as \*\* symbols at Sending Data.

- If communication with the host is normal, the reply from the host is displayed at Received Data as \*\* symbols.
- If a communication error occurs while checking the communication conditions with the host, a communication error screen is displayed. Since this indicates that there is a communication fault, check the communication cables and settings.

**For Memory Link****Example:** Serial port A while using the memory link

```
<MEMORY LINK CHECK>      Quit
Check the setting of memory SW
and PLC, and connect PT to PLC
with the Comm.A
Received Data
FF FF FF FF FF FF FF FF FF FF
FF FF FF FF FF FF FF FF FF FF
FF FF FF FF FF FF FF FF FF FF
```

The check is started as soon as the check screen is displayed. Send the command from the host.

- If communication with the host is normal, the data received from the host is displayed in hexadecimal text code at Received Data.
- If nothing is displayed at Received Data when the command is sent from the host, there is a communication fault: check the communication cables and settings.

**For a Bar Code Reader**

```
<BAR-CODE READER CHECK>  Quit
Check the setting of memory SW
and PLC, and connect PT to PLC
with the Comm.A
Received Data
FF FF FF FF FF FF FF FF FF FF
FF FF FF FF FF FF FF FF FF FF
FF FF FF FF FF FF FF FF FF FF
```

The check starts when the check screen is displayed. Read data with the bar code reader in this status.

- If communication with the bar code reader is normal, the read character strings are displayed in hexadecimal text code at Received Data.
- If nothing is displayed at Received Data when data is read with the bar code reader, there is a communication fault: check the communication cables and settings.

**Check Method**

Check communication with the serial ports by following the menu operation from the System Menu shown below.

<b>[SYSTEM MENU]</b>	Ver 1.00	Select Maintenance Mode.
Quit		
Transmit Mode		
Maintenance Mode		
Expansion Mode		

↓

<b>[MAINTENANCE MODE MENU]</b>		Select I/O Check.
Quit	Disp. History	
Memory Init.	Alarm History	
Memory Switch	Scr. Data Disp.	
Calendar Check	I/O Check	
PT Settings		

↓

<b>[I/O CHECK MENU]</b>		Select I/F Check.
Quit		
I/F Check		
Device Check		

↓

<b>[I/F CHECK MENU]</b>		Select Comm. Port A or Comm. Port B. The check screen is displayed (Check screen, page 163).
Quit		
Tool Comm.		
Comm. Port A		
Comm. Port B		

After confirming the result of the check, press Quit. The NT21 returns to the I/F CHECK MENU screen.

## 6-12 Programming Console Function

The NT21 has been equipped with a Programming Console function, which allows it to be used like a C200H-PRO27-E Programming Console for CPM1, CPM2A, CPM2C, CQM1, CQM1H, C200HX/HG/HE (-Z)E, CS-series CS1G/CS1H, CS1G-H/CS1H-H, CJ-series CJ1G, or SRM1 PCs.

Except for recording (saving) ladder programs on cassette tape and replaying (reading) them, almost all the functions of a Programming Console can be executed.



**Note** When the Programming Console function is used, carefully check that the system is safe before carrying out the following operations. Otherwise the system may operate unpredictably.

- Changing monitor data
- Switching the operating mode
- Forced set or reset
- Changing a present value or set value

### 6-12-1 Compatible Systems

The Programming Console function can communicate with the PC with the communication methods indicated in the following table.

Communication Method	Applicable PCs	Connected Port
1:1 NT Link	C200HE-CPU42-(Z)E <sup>(*1)</sup> C200HG-CPU43-(Z)E <sup>(*1)</sup> C200HG-CPU63-(Z)E <sup>(*1)</sup> C200HX-CPU44-(Z)E <sup>(*1)</sup> C200HX-CPU64-(Z)E <sup>(*1)</sup> C200HX-CPU65-ZE <sup>(*1)</sup> C200HX-CPU85-ZE <sup>(*1)</sup> CPM2A-30CD□□-□ <sup>(*1)</sup> CPM2A-40CD□□-□ <sup>(*1)</sup> CPM2A-60CD□□-□ <sup>(*1)</sup> CPM2C-10□□□□□□-□ <sup>(*2)</sup> CPM2C-20□□□□□□-□ <sup>(*2)</sup> CQM1-CPU4□-EV1 <sup>(*1)</sup> CQM1H-CPU21 <sup>(*1)</sup> CQM1H-CPU51 <sup>(*1)</sup> CQM1H-CPU61 <sup>(*1)</sup> SRM1-C02-V2	CPU Unit's built-in RS-232C port
	CPM1-10CDR-□ CPM1-20CDR-□ CPM1-30CDR-□ CPM1A-10CD□-□ CPM1A-20CD□-□ CPM1A-30CD□-□ CPM1A-40CD□-□	Peripheral port <sup>(*3)</sup>
1:N NT Link	CS1G-CPU42-E(V1) <sup>(*1)</sup> CS1G-CPU43-E(V1) <sup>(*1)</sup> CS1G-CPU44-E(V1) <sup>(*1)</sup> CS1G-CPU45-E(V1) <sup>(*1)</sup> CS1H-CPU63-E(V1) <sup>(*1)</sup> CS1H-CPU64-E(V1) <sup>(*1)</sup> CS1H-CPU65-E(V1) <sup>(*1)</sup> CS1H-CPU66-E(V1) <sup>(*1)</sup> CS1H-CPU67-E(V1) <sup>(*1)</sup> CS1G-CPU42H CS1G-CPU43H CS1G-CPU44H CS1G-CPU45H CS1H-CPU63H CS1H-CPU64H CS1H-CPU65H CS1H-CPU66H CS1H-CPU67H CJ1G-CPU44 CJ1G-CPU45	<ul style="list-style-type: none"> <li>• CPU Unit's built-in RS-232C port</li> <li>• Peripheral port <sup>(*4)</sup></li> </ul>

\*1: The peripheral port Programming Console always has priority. If a Programming Console is connected later, the Programming Console function of the NT21 is invalidated and operation from the NT21 becomes impossible.

- \*2: The CPM2C-CN111 Connecting Cable splits the PC's Communication Port into a RS-232C port and a peripheral port.
- \*3: An RS-232C cable cannot be directly connected to the peripheral port. An RS-232C adapter (CPM1-CIF01) is required.
- \*4: The RS-232C cable cannot be directly connected to the peripheral port. An RS-232C Adapter (CS1W-CN118) is required.

**Reference:** Note that the Programming Console function cannot be used with CPM1, CQM1, and C200HX/HG/HE PCs of the following lot numbers.

CPM1: □□□5, □□\*6

where \* is a number in the range 1 to 9 or the letter X or Y.

CQM1: □□□3, □□□4, □□□5, □□\*6

where \* is a number in the range 1 to 9 or the letter X or Y.

C200HX/HG/HE: □□□5 □□\*6

where \* is a number in the range 1 to 9 or the letter X or Y.

## 6-12-2 Connection Method

### CQM1, CQM1H, C200HX/HG/HE(-ZE), or SRM1

The connection method is exactly the same as for the 1:1 NT Link. Refer to *Section 4 Connecting to the Host from the RS-232C Port* or *Section 5 Connecting to the Host from the RS-422A/485 Port* for details on connecting to the PC.

- \* When using the Programming Console function with a CQM1H, turn ON pin 7 of the DIP switch on the front of the CQM1H's CPU Unit.

### CPM1 or CPM2A

The connection method is the same as for the 1:1 NT Link. With a CPM1, connect the RS-232C cable to the peripheral port via a CPM1-CIF01 RS-232C Adapter or CPM1-CIF11 RS-422A Adapter.

Refer to *Section 4 Connecting to the Host from the RS-232C Port* or *Section 5 Connecting to the Host from the RS-422A/485 Port* for details on connecting to the PC.

### CPM2C

The connection method is the same as for the 1:1 NT Link. Connect to the PC's communications connector with a CPM2C-CN111, CS1W-CN114/118 Connecting Cable, a CPM1-CIF01 RS-232C Adapter, or a CPM1-CIF11 RS-422A Adapter.

Refer to *Section 4 Connecting to the Host from the RS-232C Port* or *Section 5 Connecting to the Host from the RS-422A/485 Port* for details on connecting to the PC.

- \* When using the Programming Console function with a CPM2C, turn ON pin 2 of the DIP switch on the front of the CPM2C's CPU Unit.

### CS1G/CS1H, CS1G-H/CS1H-H, or CJ1G

The connection method is exactly the same as for the 1:N NT Link (standard or high-speed). Refer to *Section 4 Connecting to the Host from the RS-232C Port* or *Section 5 Connecting to the Host from the RS-422A/485 Port* for details on connecting to the PC. The standard or high-speed 1:N NT Link can be used.

The Programming Console function can be used only when the PT's unit number is set to 0. Only one Unit using the Programming Console function can be connected to each of the PC's ports (built-in RS-232C port and peripheral port).

With the CS1G/CS1H, CS1G-H/CS1H-H, and CJ1G PCs, the Programming Console function can be used simultaneously at both the built-in RS-232C port and peripheral port. Furthermore, the Programming Console function can be started at the RS-232C port while a Programming Console is connected to the peripheral port.

### 6-12-3 Method of Use

The Programming Console screen is displayed by operating the system menu as described below.

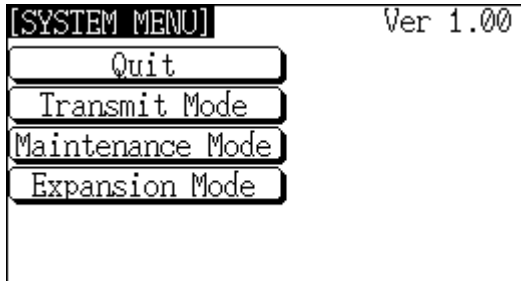

Select Expansion Mode.

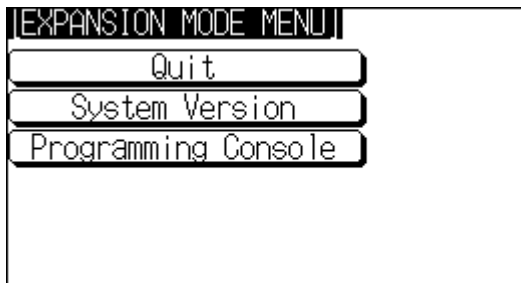

Select Programming Console.

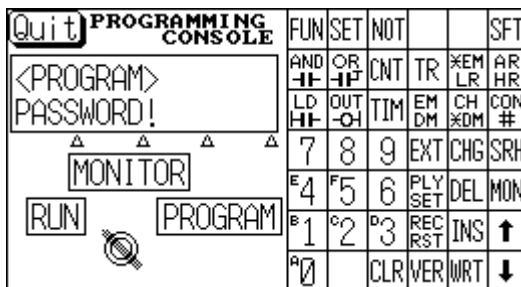

The Programming Console screen is displayed.

Press the Programming Console sheet keys (touch switches) for the operation.

Press the Quit touch switch to exit the screen.

An error is displayed if a wrong communication protocol is selected or a Programming Console is connected to the peripheral port.\*1

\*1: With the CS1G/CS1H, CS1G-H/CS1H-H, and CJ1G PCs, the Programming Console function can be used simultaneously at both the built-in RS-232C port and peripheral port.

**Reference:** When an error screen is displayed, press the Check touch switch on the screen to return to the system menu. In addition, pressing two of the four corners of the touch panel simultaneously in the error screen enables the display of the system menu.

Only points of difference with an actual Programming Console are described here. For details on using NT21 as a Programming Console, refer to the *Operation Manual* for the Programming Console (C200H-PRO27-E) or PC.

Key Operations

**Mode Selection Keys, Mode Lock Key**

The display element on the Programming Console screen shown below comprises the mode selection keys, which change the operation mode of the PC, and the mode lock key, which prevents unintended mode changes.

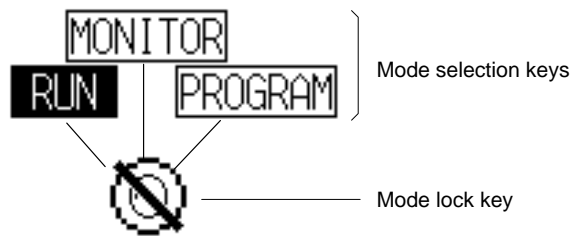

The RUN, MONITOR, and PROGRAM mode selection key elements are touch switches and pressing them causes the PC operation mode to change (unlike an actual Programming Console, it is possible to switch directly between the RUN mode and the PROGRAM mode.)

When the Programming Console function is started, the PC operation status is read and reflected at the PC.

The mode lock key element is also a touch switch, and it alternates between the lock ON (with no key displayed) and lock OFF (with key displayed) states when pressed. During the lock ON state, mode selection key operations are ineffective. The mode displays change as indicated in the figures below during the lock ON status and during the lock OFF status.

When the Programming Console function starts, the lock ON status is established.

If the RUN, MONITOR, or PROGRAM mode selection key is pressed in the lock OFF status, the mode changes and the lock ON status is established.

**During Lock OFF**

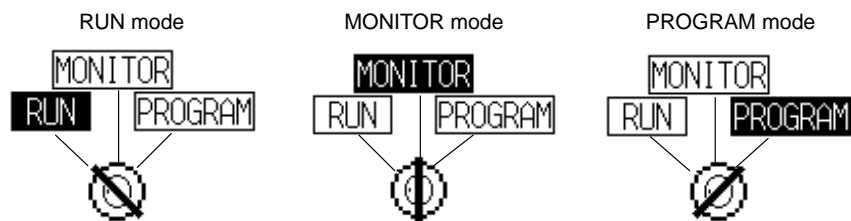

**During Lock ON**

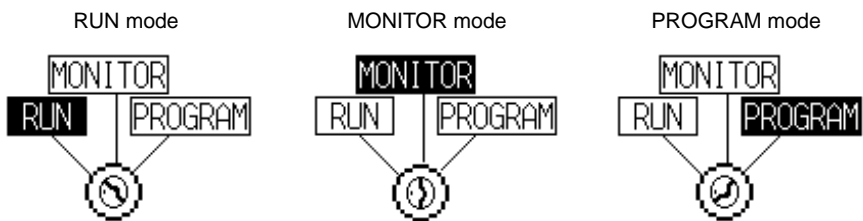

**Programming Console Keyboard**

The Programming Console keyboard used on the screen when the Programming Console function is used is comprised entirely of touch switches (shown by the dashed line frames in the figure below). On pressing a touch switch, a key operation is executed. However, since there is a discrepancy between the size of the displayed keys and the size of the touch switches, take care to press as close to the center of the key as possible by referring to the figure below.

In addition, if the connected host is a CS1G/CS1H, CS1G-H/CS1H-H, or CJ1G PC, the Programming Console key sheet for the CS/CJ series is automatically displayed.

## Standard Programming Console Key Sheet

Quit		PROGRAMMING CONSOLE		FUN	SET	NOT			SFT
AND	OR	CNT	TR	EM	AR				
LD	OUT	TIM	EM	CH	CON				
HI	LO		DM	DM	#				
7	8	9	EXT	CHG	SRH				
E4	F5	6	PLY	DEL	MON				
			SET						
B1	C2	D3	REC	INS	↑				
			RST						
A0			CLR	VER	WRT				↓

## Programming Console Key Sheet for CS/CJ Series

Quit		PROGRAMMING CONSOLE		FUN	SET	NOT	IR+	DR	SFT
AND	OR	TK	-IR	EM	AR				
LD	OUT	CNT	TR	DM	CON				
HI	LO			DM	#				
7	8	9	EXT	EXT	CHG	SRH			
E4	F5	6	SET	DEL	MON				
B1	C2	D3	RST	INS	↑				
A0	TXT		CLR	VER	WRT				↓

## Differences with Respect to Programming Consoles

- Programs cannot be stored (recorded) or read (replayed). If it is necessary to store or read a program, use a Programming Device.
- It is not possible to adjust the volume of the key press sound. Whether or not the key press sound sounds is determined by the setting for the Key Press Sound memory switch of the NT21. It sounds when the setting is ON and does not when the setting is OFF (page 136).
- If an error occurs when using the Programming Console function, an error screen is displayed. Whether or not the buzzer sounds at this time is determined by the setting for the Buzzer Sound memory switch of the NT21 (page 137).

**Reference:** A communications error will occur if you use the Programming Console function to change the communications settings (in the PC's PC Setup) that govern the port to which the NT21 is connected. In this case, the Programming Console function will be unusable.

## 6-13 Version Display

Use the Version Display function to check the version of the NT21's system program. The Version Display screen shows the model, creation date, and version of the system program installed in the NT21.

## 6-13-1 Method of Use

The Version Display screen is displayed by operating the system menu as described below.

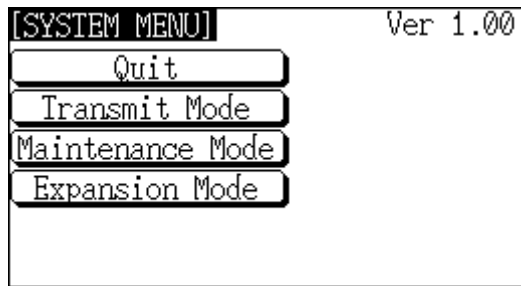

Select Expansion Mode.

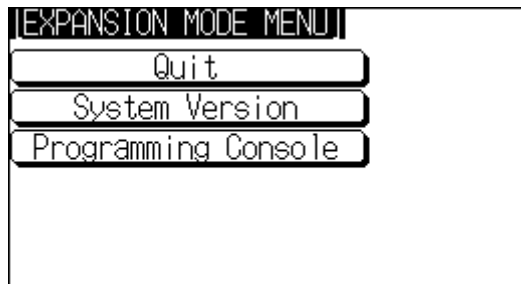

Select Version Display.



The system program's version information will be displayed as described below. Press the Quit touch switch to exit the Version Display screen and return to the Expansion Mode screen.

- PT Model: PT model number
- System program: System program name
- Version System program version
- Date Date program was created.

This screen is an example. Actual screens will show the information specific to the PT and system program being used.

After checking the version information, press the Quit touch switch to exit the Version Display screen and return to the Expansion Mode screen.

- Reference:**
- The PT model always shows the model number of the ivory model of the PT. The B suffix will not be displayed, even for black models.
  - The system program's version number is also displayed in the upper-right corner of the System Menu.
  - The creation date does not always match the file date of the system program installed with the System Installer.

# SECTION 7

## Troubleshooting and Maintenance

This section describes the action to take when errors occur in the PT, and how to carry out maintenance and inspection to prevent the occurrence of errors.

7-1	Troubleshooting .....	174
7-2	Responding to Displayed Error Messages .....	176
7-2-1	Errors Occurring at Start of Operation and Their Remedies .....	177
7-2-2	Errors Occurring during Operation and Their Remedies .....	179
7-2-3	Errors Occurring on Screen Data Initialization and Transmission .....	180
7-2-4	Errors in the System Installer Mode and Their Remedies .....	181
7-2-5	Communication Errors and Their Remedies .....	181
7-3	Maintenance of the NT21 .....	183
7-3-1	Installing or Replacing the Battery .....	184
7-4	Inspection and Cleaning .....	185



## 7-1 Troubleshooting

When a fault relating to the operation of the NT21 occurs, find the symptoms in the table below and respond by following the corresponding *Remedy* indicated in the table.

- Note**
1. Confirm system safety before turning the power ON/OFF.
  2. Do not disassemble the PT for repair or modification. Otherwise the product may malfunction.

NT21 Symptoms	Cause	Remedy
Nothing is displayed on the screen.	Power is not being supplied.	Check the connections and make sure that power is supplied correctly. (3-1-3 <i>Power Supply Connection</i> , page 17)
	Power supply fuse has blown.	Contact your OMRON service center.
	Screen No. 0 has been read at the host side.	This is not an error. Change the screen number from screen number 0. (Setting the screen number to 0 turns the screen off.)
	The system startup waiting time has not elapsed yet.	This is not an error. The display will appear after the waiting time has elapsed.
Cannot communicate with the NT Support Tool	The Transmit mode has not been established.	Display the System Menu and select the Transmit mode. (6-6 <i>Transmitting the Screen Data</i> , page 123)
	Not connected to the NT Support Tool.	Check the installation of the connector cable. (3-3 <i>Connecting to the NT Support Tool</i> , page 28)
	The PT model setting and direct connection setting at the NT Support Tool do not match the NT21.	Using the PT Configuration settings of the NT Support Tool, set the PT model and direct connection settings that match the NT21.
Cannot communicate with the host Cannot switch from the system initializing screen. Communication error message is displayed when communicating to the host.	Memory switch settings do not match.	Check the communication setting in the Memory Switch menu of the Maintenance mode, and match the communication protocol settings for the host and NT21. (6-7 <i>Setting Conditions for Communications with Host by Using Memory Switches</i> , page 125)
	NT21 and host are not correctly connected.	Check that the type, length, and installation of the connector cable match the specifications. (Section 4 <i>Connecting to the Host from the RS-232C Port</i> , and Section 5 <i>Connecting to the Host from the RS-422A/485 Port</i> )
	An RS-422A/485 connection is being used and the terminator setting is incorrect.	Make the Link Adapter and PC terminating resistance settings correctly. (Section 5 <i>Connecting to the Host from the RS-422A/485 Port</i> )
	In an NT Link (1:N) connection, there is duplication in the unit numbers.	Make the settings again so that there is no duplication. (6-7-4 <i>Setting the NT Link (1:N) Method (Standard/High-speed)</i> , page 129)
	The power to the NT21, NT-AL001 or host is OFF.	Check the power supply.
The buzzer has sounded and the RUN Indicator is OFF.	Malfunction due to external noise	Carry out grounding work in accordance with the conditions by referring to 3-1-4 <i>Grounding</i> , page 18.
	The NT21 has developed trouble.	Contact your OMRON service center.
The touch panel does not respond.	Malfunction due to external noise	Carry out grounding work in accordance with the conditions by referring to 3-1-4 <i>Grounding</i> , page 18.
	The touch panel is broken.	Test the touch panel with I/O Check in the MAINTENANCE MODE menu. If there is an error, contact your OMRON service center.
The PC mode has changed to the monitor mode.	The NT21 changes the mode when host link communication is used.	This is an NT21 specification. When using a PC that can also be connected using the NT Link method, use an NT Link connection (there is no mode to change with the NT Link method).
The graph display does not update.	One of the percentage display settings — -100%, 0%, or 100% — is incorrect.	Set the -100%, 0%, and 100% values in the following relationship: -100% value < 0% value < 100% value

NT21 Symptoms	Cause	Remedy
The trend graph display does not agree with the actual time axis.	The cycle for graph display update processing is longer than the set sampling cycle.	Delete other elements on the same screen as the trend graph that are allocated to the host and have a high update frequency. Or lengthen the sampling cycle.
The Programming Console function cannot be used.	The communication settings are incorrect.	Set the communication method as follows when using the Programming Console function. <ul style="list-style-type: none"> <li>• With C-series PLC: 1:1 NT Link</li> <li>• With CS/CJ-series PLC: 1:N NT Link (standard or high-speed)</li> </ul>
	A Programming Console is connected.	The Programming Console and the Programming Console function can be used at the same time in CS/CJ series PCs only. If another model of PC is being used, disconnect the Programming Console.
	The PC does not support the Programming Console function.	Not all PCs support the Programming Console function. Check the model of PC you are using. (6-12 Programming Console Function, page 165)
The memory table display contents differ from the initial value set at the NT Support Tool.	Since the memory table is allocated to the host memory, the display is updated in accordance with the contents of the host memory.	When the contents of the memory table are set as a fixed values, do not allocate the memory table to the host memory.
	An optional battery was installed, but the battery has weakened and the data in the memory table has been lost.	Replace the battery and initialize the memory table. (7-3-1 Installing or Replacing the Battery, page 184, and 6-4-4 Initializing the Memory Tables, page 114)
	An optional battery was installed and the resume function is set to ON, so the initial values set with the NT Support Tool are not reflected in the memory tables.	Execute memory table initialization. (6-4-4 Initializing the Memory Tables, page 114) If the resume function does not need to be used, set the NT21 with the resume function OFF. (6-9-8 Setting the Resume Function, page 140)
	The numeral memory table is specified as the destination for a mathematical table results.	Calculations are executed continuously while the PT is operating and the calculation results are automatically written to the memory table. Specify another numeral memory table entry or a word in the host.
Updating of numeric values and text is delayed.	Malfunction due to external noise	Carry out grounding work in accordance with the conditions by referring to 3-1-4 Grounding, page 18.
	There are too many numeral/text displays on the displayed screen.	Reduce the number of numeral/text displays on the screen for which updating is delayed.
	The cycle time is extended due to heavy processing at the host.	Shorten the host cycle time.
	In an RS-422A/485 connection, there is illegal branching or an erroneous terminator setting.	Wire correctly by referring to Section 5 Connecting to the Host from the RS-422A/485 Port.
Some of the elements arranged on a normal screen are not displayed.	The quantity of read data exceeds the stipulated restriction.	Check the maximum number of elements by referring to Display Restrictions in Appendix A of the Reference Manual. Create the screen data again and then transmit all of the screen data in a batch to the NT21.
	The total of the element coefficients for the displayed screen is greater than 1024.	
On overlapping screens, some of the set elements are not displayed.	Since the data is transmitted from the host in screen units, the number of elements on the overlapping screens has exceeded the maximum permissible without being checked by the NT Support Tool.	Check the maximum number of elements by referring to Display Restrictions in Appendix A of the Reference Manual. Create the screen data again and then send all the screen data in a batch to the NT21.
The System Menu cannot be called up.	Display System Menu under Change System Settings in the System Installer mode is set to Disabled.	In the System Installer mode, set Display System Menu to Enabled (page 121).

NT21 Symptoms	Cause	Remedy
The following System Menu operations are not possible. - Establishing the Transmit mode - Displaying the memory switch setting screens - Screen data memory check - Displaying the initialization menu	Screen Memory Protect under Change System Setting in the System Installer mode is set to Disabled.	In the System Installer mode, set Screen Memory Protect to Enabled (page 121).
	Screen Memory Protect has been set to Disabled because the PT power supply was turned OFF during deletion of screen data.	Do not turn the PT power OFF during deletion of screen data. In the System Installer mode, first change the setting for Screen Memory Protect to Enabled, then repeat the screen data delete operation (pages 121 and 121)
Cannot input numeric values	The upper/lower (max./min.) limit check for numeric value input is in effect.	Check the screen data's upper/lower (max./min.) limit check setting for numeric value input, and correct it if necessary. Refer to 2-12 <i>Inputting Numeric Values</i> in the Reference Manual for details.
Cannot input numeric values/character strings.	Bit 5 of the PT Status Control Area (numeral/character string input) is set to 1 (ON).	Set bit 5 to 0 (OFF). Refer to 2-2-1 <i>PT Status Control Area (Host ↔ PT)</i> in the Reference Manual for details.
	The interlock function is set for the input field and the controlling interlock bit is OFF.	Inputs are prohibited in input fields when the corresponding interlock bit is OFF. Check the status of the corresponding interlock bit and turn it ON.
Window screen does not open	Bit 6 of the PT Status Control Area (PT window opening) is set to 1 (ON).	Set bit 6 to 0 (OFF). Refer to 2-2-1 <i>PT Status Control Area (Host ↔ PT)</i> in the Reference Manual for details.
Cannot switch screens with touch switches	Bit 4 of the PT Status Control Area (PT screen switching) is set to 1 (ON).	Set bit 4 to 0 (OFF). Refer to 2-2-1 <i>PT Status Control Area (Host ↔ PT)</i> in the Reference Manual for details.
Touch switch does not work. (Buzzer sounds.)	The interlock function is set for the touch switch and the controlling interlock bit is OFF.	Touch switches are disabled when the corresponding interlock bit is OFF. Check the status of the corresponding interlock bit and turn it ON.
The display is dim.	The contrast setting is too low.	Increase the contrast with the contrast adjustment on the back of the NT21.
	Backlight defective, or its life has expired.	Contact your OMRON service center. (The backlight cannot be removed.)
The display is too faint.	The contrast setting is too high.	Reduce the contrast with the contrast adjustment on the back of the NT21.
The digits in numeral display come out as *.	The number of digits of a numeric value in a numeral memory table entry exceeds the set number.	<ul style="list-style-type: none"> <li>• Confirm the values of the PC words allocated to the numeral memory table.</li> <li>• Allocate one PC word to each numeral memory table entry.</li> </ul>

## 7-2 Responding to Displayed Error Messages

When the NT21 displays an error message, find the corresponding symptoms in the appropriate table below and respond by following the Remedy indicated in the table. For details of the error messages displayed when using Memory Unit and corrective action to take for them, refer to 3-5 *Using a Memory Unit* in page 31.

### 7-2-1 Errors Occurring at Start of Operation and Their Remedies

The table below shows the errors that can occur when the power to the NT21 is turned ON and when operation starts, and their remedies.

Message	Cause	Remedy
[No Comm. Protocol] Set the comm. Protocol by MAINTENANCE MODE.	No communication protocol has been set. Communication protocol and screen data type are mismatched	Using the memory switches, set the communication method to be used for communication with the host. (6-7 <i>Setting Conditions for Communications with Host by Using Memory Switches</i> , page 125)
[Screen Data Error] Screen Data corrupted. Initialize Screen Memory, and download Screen Data again.	<ul style="list-style-type: none"> <li>- The power was switched OFF during screen data initialization, checking, or transmission.</li> <li>- Transmission of screen data was interrupted.</li> <li>- Illegal data has been written to the screen data memory.</li> </ul>	<p>Initialize the screen data memory by operation at the System Menu, then re-transmit the screen data. (6-4-1 <i>Clearing Screen Data</i>, page 110)</p> <p>If the problem persists, contact your OMRON service center.</p>
[No Screen Data] No Screen Data is saved in Screen Memory. Download Screen Data using by the NT Support Tool.	No screen data is registered.	Transmit screen data from the NT Support Tool.
[No Direct Connection Info.] No Direct Connection Information is set in Screen Data. Set Direct Connecting Information in Screen Data using by the NT Support Tool. Then set the PT to the TRANSMIT MODE and download Screen Data again.	Allocated words have not been set for the PT Status Control Area and PT Status Notify Area.	Allocate words for the PT Status Control Area and PT Status Notify Area with the NT Support Tool and then transmit the direct connection information to the NT21.
[Incorrect Screen Data] Screen Data in Screen Memory do not match with the System Program. Initialize Screen Memory, and download Screen Data again.	The type of registered screen data does not match that at the NT21.	Initialize the screen data memory, then transmit the correct screen data. (6-4-1 <i>Clearing Screen Data</i> , page 110)
[No Starting Screen] Specified Starting Screen is not saved. Fix Screen Data using by the NT Support Tool. Then set the PT to the TRANSMIT MODE and download Screen Data again.	<p>No data is registered for either the screen number set in the PT Status Control Area or the Initial Screen set with the NT Support Tool.</p> <p>Or screen numbers that do not exist are registered.</p>	Either specify a screen number for which data is registered at the PT Status Control Area, or set the screen as the Initial Screen in the System settings under PT Configuration at the NT Support Tool.
[Memory Switch Corrupted] Because Memory Switch setting was lost. Initialized Memory Switch setting. Press Confirm to return to the SYSTEM MENU.	The memory switches have been initialized due to discovery of an error in the memory switch settings.	<p>Set the memory switches again using the System Menu and the System settings under PT Configuration at the NT Support Tool. (<i>Section 6 System Menu Operation</i>)</p> <p>If the problem recurs, contact your OMRON service center.</p>

<b>Message</b>	<b>Cause</b>	<b>Remedy</b>
<p>[Backup Data Error] Memory table and History data was initialized by backup failure. It can be caused by lowered voltage of the battery.</p>	<p>Initialization has been executed because of an error in the backup data area.</p>	<p>Check the battery voltage by checking the color of the RUN Indicator and with the battery check in the System Menu; if the voltage is low, replace the battery with a new one. (<i>Checking the Battery Voltage</i>, page 160, and <i>7-3-1 Installing or Replacing the Battery</i>, page 184) Then re-transmit the memory table data from the NT Support Tool.  If the voltage is normal and the problem recurs, contact your OMRON service center.</p>
<p>[With memory switch setting screen] Invalid Comm. Method</p>	<p>Protocol settings for serial port A and serial port B are mismatched.</p>	<p>Refer to Possible Combinations of Communication Method Settings on page 126 and set the protocol of serial port A and serial port B so that their settings are matched.  * Set serial port A to None when connecting the NT Support Tool and the host at the same time.</p>

### 7-2-2 Errors Occurring during Operation and Their Remedies

The table below shows the errors that can occur during operation of the NT21 and their remedies.

Message	Cause	Remedy
[Address Setting Error] Addressing Error exists in the Screen. Correct address setting by the NT Support Tool.	The host side allocated words and bits set with the NT Support Tool are incorrect.	Set correct words and bits after checking the area used at the host side by referring to PC Memory Map in <i>Appendix D</i> of the <i>Reference Manual</i> or the operation manual for the PC being used.
[Memory Table No. Error] Memory table entry number is out of limit. Correct the table entry number by the NT Support Tool.	The memory table entry number set with the NT Support Tool is outside the range for the number of entries in the memory table set in the system memory.	Either increase the number of memory table entries in the System settings under PT Configuration at the NT Support Tool, or set the memory table entry number again within the established range. Then transmit all of the screen data in a batch to the NT21.
[Programming Console Error] Setting of Programming Console Function is inadequate. It can be caused by: <ul style="list-style-type: none"> <li>This PLC does not support Programming Console Function.</li> <li>Protocol mismatch. Set the PLC to NT Link.</li> <li>"PROGRAMMING CONSOLE" is connected to PLC.</li> </ul>	The communication settings are incorrect.	Set the communication method/communication port as follows when using the Programming Console function. <ul style="list-style-type: none"> <li>With C-series PLCs:1:1 NT Link</li> <li>With CS/CJ-series PLCs: 1:N NT Link (standard or high-speed)</li> </ul>
	The PC used does not support the Programming Console function.	Not all PCs support the Programming Console function. Check the model of the PC you are using. ( <i>6-12 Programming Console Function</i> , page 165)
	A Programming Console is connected.	It is not possible to use a Programming Console and the Programming Console function at the same time. Disconnect the Programming Console.
[Programming Consol Error] Programming Console Function does not RUN. It can be caused by: <ul style="list-style-type: none"> <li>Connecting cable is faulty.</li> <li>"PROGRAMMING CONSOLE" is connected to PLC.</li> <li>Protocol mismatch between the PT and PLC. Set the PLC to NT Link.</li> </ul>	The connecting cable is defective.	Check the cable connection and perform a conductivity test. If there is a fault, replace the cable.
	Malfuction due to external noise	Carry out grounding work in accordance with the conditions by referring to <i>3-1-4 Grounding</i> , page 18.
	A Programming Console is connected.	A Programming Console and the Programming Console function can be used at the same time in CS/CJ series PCs only. If another PC is being used, disconnect the Programming Console.
	The communication conditions at the PC have been changed in accordance with the NT21 Programming Console function.	Set the communication conditions at the PC to match the conditions set in the System Menu.

### 7-2-3 Errors Occurring on Screen Data Initialization and Transmission

The table below shows the errors that can occur when the NT21 data is initialized, and during data setting and transmission, and their remedies.

Message	Cause	Remedy
[Flash Memory Error] Flash Memory I/O Error. If this happens frequently, Flash Memory may be broken. Press Reset Switch to restart.	There is a hardware fault, or the flash memory (memory for storing screen data) has reached the end of its service life.	If the same message is displayed even after clearing the screen data or transmitting screen data several times, contact your OMRON service center.
[Tool Transmit Error] **** Error detected while downloading by the following case: <ul style="list-style-type: none"> <li>• faulty connecting cable.</li> <li>• corrupted data by noise.</li> </ul>	The connecting cable is defective.	Check the cable connection and perform a conductivity test. If there is a fault, replace the cable. ( <i>Appendix E Making the Cable for Connecting a PC</i> , page 199)
	Malfunction due to external noise	Carry out grounding work in accordance with the conditions by referring to <i>3-1-4 Grounding</i> , page 18.
[Tool Transmit Error] Check Sum Error occurs while downloading by the following case: <ul style="list-style-type: none"> <li>• corrupted data by noise.</li> </ul>	Malfunction due to external noise	Carry out grounding work in accordance with the conditions by referring to <i>3-1-4 Grounding</i> , page 18.
[Tool Transmit Error] Time-out Error occurs while downloading by the following case: <ul style="list-style-type: none"> <li>• faulty connecting cable.</li> </ul>	The connecting cable is defective.	Check the cable connection and perform a conductivity test. If there is a fault, replace the cable.
[Tool Transmit Error] Reception was failed by Buffer Over Flow Error.	The receive buffer has overflowed.	Retransmit the data from the NT Support Tool.

### 7-2-4 Errors in the System Installer Mode and Their Remedies

This section describes the errors that may occur in the System Installer mode of the NT21, and the remedies for these errors.

Message	Cause	Remedy
System Program not exist or incorrect.	<ul style="list-style-type: none"> <li>- The system program has not been installed.</li> <li>- The system program has been deleted due to a hardware fault, or because the flash memory (memory for storing the system program) has reached its life.</li> </ul>	<p>Select Download System Program and download the system program (6-5-2 <i>Clearing/Installing the System Program</i>, page 119).</p> <p>If this does not solve the problem, contact your OMRON service center.</p>
Unable to erase System Program.	Hardware fault, or flash memory (memory for storing the system program) has reached its life.	If the same message is displayed on repeating selection of Download System Program and attempting to delete the system program several times, contact your OMRON service center (6-5-2 <i>Clearing/Installing the System Program</i> , page 119).
Unable to download System Program.	<ul style="list-style-type: none"> <li>- A communication error occurred during downloading of the system program.</li> <li>- Illegal data has been written into the screen data memory.</li> <li>- Hardware fault, or flash memory (memory for storing the system program) has reached its life.</li> </ul>	<p>Select Download System Program and download the system program again (6-5-2 <i>Clearing/Installing the System Program</i>, page 119).</p> <p>Also refer to 7-2-3 <i>Errors Occurring on Screen Data Initialization and Transmission</i> (page 180), and take the corrective action described for tool transmission errors.</p> <p>If this does not solve the problem, contact your OMRON service center.</p>
Unable to write System Settings.	Hardware fault, or flash memory (memory for storing the system program) has reached its life.	<p>If the same message is displayed on repeating writing of system settings several times, contact your OMRON service center.</p> <p>If writing is normally terminated after the error message was once displayed, the Memory Switch setting for system program may have been altered. In such a case, check and re-set the setting in the Memory Switch menu of the Maintenance mode.</p>
Unable to erase Screen Data.	Hardware fault, or flash memory (memory for storing the system program) has reached its life.	If the same message is displayed on repeating screen data deletion several times, contact your OMRON service center.

### 7-2-5 Communication Errors and Their Remedies

This section describes the errors relating to communication that can occur during operation, and their remedies.

**Operation When a Communication Error Occurs**

When a communication error occurs, the error message is displayed at the NT21, and the buzzer sounds, provided the setting made for Buzzer Sound in the System Menu is other than OFF. An error message is displayed provided the setting for the Comm. Auto-Return memory switch is not ON (note that some error messages are displayed even if the setting is ON).

**Operation When Communication Errors Occur**

When an error message is displayed, press the OK touch switch displayed on the screen. The NT21 will return to the screen that was displayed before the error occurred, and operation will restart.

**Display of Communication Errors**

For communication errors, the name of the port at which the error occurred, the error classification (send or receive error), the details of the error, the probable cause, and the remedy, are displayed as shown below.



**Example:**  
Parity error at serial port A

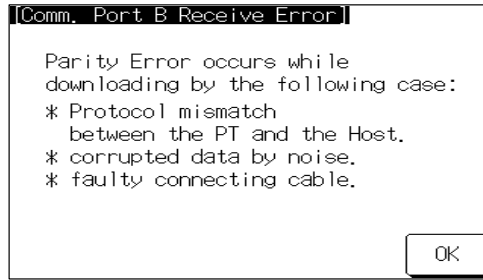

**Receive Errors**

The following errors can occur when receiving data.

- Parity error
- Framing error
- Overrun error
- FCS (sum value) error
- Time out error
- Data over flow error
- PC unit number error (host link only)
- NAK received (in the case of the host link, the end code is also displayed)
- Undefined command error

**Send Errors**

The following errors can occur when receiving data.

- Time out error
- Data over flow error

**Probable Causes and Remedies**

The remedies to take in accordance with the displayed cause are indicated in the table below.

Error Details	Displayed Probable Cause	Remedy
Parity Error Framing Error Over-run Error	Communication parameters/ conditions set incorrectly.	Check if the settings at the host for parity bit, frame length, baud rate, stop bit length and flow control agree with those at the NT21.
	The connecting cables are not connected correctly.	Check the communication cable connection and perform a conductivity test. If there is a fault, replace the cable. For details on communication cables, refer to <i>Section 4 Connecting to the Host from the RS-232C Port</i> , and <i>Section 5 Connecting to the Host from the RS-422A/485 Port</i> .
	Noise caused data corruption during communication.	Carry out grounding work in accordance with the conditions by referring to <i>3-1-4 Grounding</i> , page 18.
FCS (Check Sum) Error	Noise caused data corruption during communication.	Carry out grounding work in accordance with the conditions by referring to <i>3-1-4 Grounding</i> , page 18.
	The PC is transmitting incorrect data.	Check the operation at the host side.

Error Details	Displayed Probable Cause	Remedy
Time-out Error	The connecting cables are not connected correctly. (Send/Receive)	Check the communication cable connection and perform a conductivity test. If there is a fault, replace the cable. For details on communication cables, refer to <i>Section 4 Connecting to the Host from the RS-232C Port</i> , and <i>Section 5 Connecting to the Host from the RS-422A/485 Port</i> .
	The communication service of the host is stopped. (Send/Receive)	Check that the host is capable of communicating with the NT21 (confirm that the communication settings of the host and NT21 match, and connection between the host and NT21 if flow control is set).
	Time-out Interval is too short. (Send)	Set a longer value for Time-out Interval at the host side.
	Time-out Interval is too short. (Receive)	Set a longer value for Time-out Interval in the System Menu. ( <i>6-9-10 Setting the Time-out Interval</i> , page 142) It may also be possible to solve the problem by shortening the host cycle time.
PC Unit No. Error	The unit # does not match that set on the PC.	Re-set the unit number at the host side to 0.
	Noise caused data corruption during communication.	Carry out grounding work in accordance with the conditions by referring to <i>3-1-4 Grounding</i> , page 18.
NAK received	—	Check the settings for allocated words and bits. If noise is a possible factor, distance the cable from sources of noise and insert a noise filter in the power supply line. If using the equipment in a location subject to a lot of noise, use a cable with a high degree of protection against noise for the transmission route. Also make the cable as short as possible.
Undefined Command Error	The host is not supported.	Check the PC model used for the host.
	Command level 3 is not effective.	Check that the command level setting for the host is level 1, 2, 3.
Data Over Flow Error	Communication command from the host is too long. (With memory link)	Set flow control method in the host. Increase transmission interval.
	Command transmission to the host is not possible.	Check the communication cable. Check the control method at the PT and the host. Increase the baud rate if it is too slow.

## 7-3 Maintenance of the NT21

Carry out maintenance work in order to ensure that the NT21 is always used in its optimum condition.



### WARNING

Do not attempt to take the Unit apart and do not touch any internal parts while the power is being supplied. Doing either of these may result in electrical shock.



### Backing Up Screen Data

Always back up the screen data and store it in a safe place in case a problem develops and the NT21 needs to be replaced or repaired.

### Preparing a Spare PT

It is advisable to have a spare NT21 available to minimize system downtime in the event of an NT21 failure or if the screen display becomes difficult to read due to deterioration of the display unit.

### 7-3-1 Installing or Replacing the Battery

An optional lithium battery can be installed in the NT21 to backup the memory contents, data saved by the resume function, display history data, alarm history record data, and recipe data. (The battery is an optional accessory, so a battery is not installed when the NT21 is shipped from the factory.)

The battery life is about 5 years if the NT21 is used in a location where the ambient temperature is 25°C. If the temperature at the location of use is higher than this, the battery life will be shorter. Change the battery at suitable intervals in accordance with the operating environment of the NT21.

It is advisable to keep a spare battery so that the battery can be replaced immediately when replacement becomes necessary.

If a battery is installed, turn ON the Battery Low Check memory switch.

#### **Battery Model**

3G2A9-BAT08

#### **Installing the Battery**

Use the following procedure to install the battery.

- 1, 2, 3... 1. Insert a flat blade screwdriver at the top of the battery cover located at the right of the rear face of the NT21 and pull it toward you.

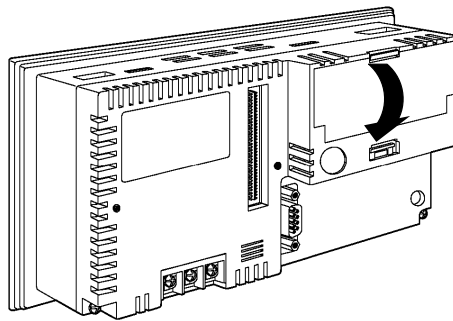

2. Mount the battery in the clips on the back of the battery cover and insert the battery's connector into the NT21's connector. When inserting the battery connector, check that the connector tab is facing right and insert the battery connector fully so that there is no space between the two connectors.

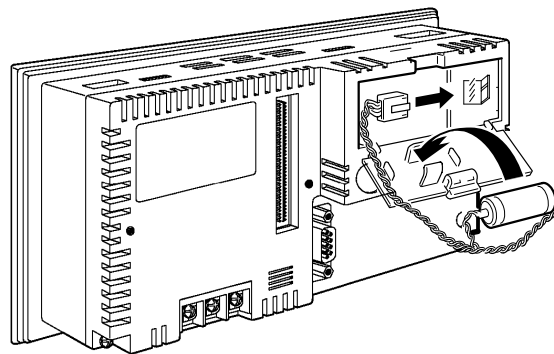

3. Arrange the battery wires so that they will not be pinched by the battery cover and close the battery cover.

#### **Replacing the Battery**

#### **When to Replace the Battery**

Replace the battery in the following cases. The battery must be replaced within 5 days.

- When 5 years have passed since the installation of a new battery.
- When the RUN Indicator is lit in orange (during operation) or in red (when stopped).

- When the message “The voltage is lowered.” is displayed when the NT21 is turned ON.
- When The voltage is lowered is displayed in the Battery check in the battery check menu of the Maintenance mode.

**Battery Replacement Procedure**

Use the following procedure to replace the battery. To preserve the contents of the memory, the battery must be replaced within 5 minutes.

- 1, 2, 3... 1. Keep the NT21’s power ON for at least 5 minutes and then turn it OFF. It is also possible to replace the battery with the power ON.

**Reference:** Unless the power is kept ON for at least 5 minutes, the memory contents cannot be retained for more than 5 minutes without a battery.

2. Remove the battery from the battery cover, grip the cable, and pull the connector straight out.
3. Refer to *Installing the Battery* above (page 184) for details on installing the new battery.

## 7-4 Inspection and Cleaning

Clean and inspect the NT21 regularly to ensure that it is always used in its optimum condition.

**Cleaning Method**

If the display is dirty the screen is difficult to see. Clean the screen from time to time as follows.

- In daily cleaning, wipe the display with a soft dry cloth. If the soiling is particularly heavy, attempting to remove it by wiping with a dry cloth may damage the front sheet of the Unit. In this case, wipe with a damp cloth.
- If the soiling cannot be removed with a dry cloth, wet the cloth with diluted neutral detergent (2%), wring it out well and wipe the display with it.
- If rubber or vinyl products, tape, etc., are left stuck to the display for long periods they will cause staining. If such items are stuck to the display, remove them during cleaning.

**Note** Never use volatile solvents such as benzene or thinners, or chemical dusters. Otherwise the product may malfunction.

**Inspection Method**

In normal environments, inspect the NT21 at intervals of between 6 months and a year. In environments that are extremely hot and humid, or very dusty environments, shorten the inspection interval.

**Items Required for the Inspection**

Prepare the following items before starting the inspection.

- Screwdrivers (Philips, flat head)
- Tester (or digital voltmeter)
- Industrial alcohol
- 100% cotton cloth
- Hygrometer (required in some cases)
- Thermometer (required in some cases)
- Synchroscope (required in some cases)
- Pen-writing oscilloscope (required in some cases)

**Points Inspected**

Inspect the following points to determine if there is any divergence from the stated criteria. If there is, either improve the surrounding environment so that the values fall within the stated range, or adjust the NT21, for example by re-tightening screws.

Point Inspected	Inspection Details	Criterion	Inspection Instrument
Power supply voltage	Fluctuation in power supply terminal voltage	Permissible voltage fluctuation range (24 VDC -15% to +15%)	Tester
Ambient environmental conditions	Ambient temperature (temperature in the operation panel)	0 to 50°C	Thermometer
	Ambient humidity (humidity in the operation panel)	35% to 85% RH	Hygrometer
	Presence/absence of dust	Dust must not be settled	Visual inspection
Mounting conditions	Looseness of mounting brackets, etc.	To be no looseness	Philips screwdriver
	Connector connections of connecting cable	To be fully inserted and locked, with no looseness	Philips screwdriver
	Looseness of screws in external wiring	To be no looseness	Philips screwdriver
	Conditions of external connecting cables	Faults such as incipient disconnection	Visual inspection
Components with limited lives	Brightness of the backlight	Must be sufficiently bright. Backlight life: At normal ambient temperature and humidity, the backlight brightness will drop to about 50% of its original brightness after 50,000 hours of use.	Visual inspection

- Note**
1. Do not disassemble for repairs or modification. Otherwise the product may malfunction.
  2. The disposal of the Unit and spent batteries may be regulated by national or local authorities. Dispose of them in accordance with the laws and regulations of the relevant country and local authority.

**Reference:** Desire on replacing the NT21

When replacing the NT21 after discovering a fault during inspections, note the following points:

- Be sure to switch the power OFF before starting replacement.
- After replacement, check that the new NT21 is not subject to the same error.
- If a faulty Unit is returned for repairs, write as detailed a description of the fault as possible and send this description together with the Unit to the OMRON address indicated on the back cover of this book.

# Appendix A Specifications

## General Specifications

Item	Specification
Rated power supply voltage	24 VDC
Allowable power supply voltage range	20.4 VDC to 27.6 VDC (24 VDC –15% to +15%)
Allowable power interruption time	No regulation
Power consumption	7 W max.
Ambient temperature	Operating: 0 to +50°C Storage: –20 to +70°C
Operating ambient humidity	35% to 85% humidity at 0 to 40°C (with no condensation) 35% to 55% humidity at 40 to 50°C (with no condensation)
Operating environment	No corrosive gases
Noise resistance	Conforms to IEC 61000-4-4. 2,000 V (power supply line)
Vibration resistance (operating)	10 to 57 Hz with 0.075 mm amplitude and 57 to 150 Hz with 9.8 m/s <sup>2</sup> acceleration for 60 minutes in each of X, Y, Z directions
Shock resistance (operating)	147 m/s <sup>2</sup> , 3 times in each of X, Y, and Z directions
Dimensions	190 (W) × 110 (H) × 53.5 (D) mm (With Expansion Unit mounted: 190 (W) × 110 (H) × 73.5 (D) mm)
Panel cutout dimensions	178.5 <sup>+0.5</sup> <sub>0</sub> × 100.5 <sup>+0.5</sup> <sub>0</sub> mm Panel thickness range: 1.6 to 4.8 mm
Weight	0.6 kg max.
Enclosure ratings	Front panel: Equivalent to IP65F (NEMA4)*
Grounding	D-type grounding (Ground to 100 Ω or less)
International standards	UL, cULus, EC directives, C-Tick Class 1 Division 2

\* The NT21 may not be used at a location where it is exposed to splashing oil for a long period.

## Performance Specifications

### Display Specifications

Item	Specification	
Display panel	Display device	Monochrome STN LCD (with backlight)
	Number of dots (resolution)	260 dots horizontally × 140 dots vertically
	Dot pitch	0.45 × 0.45 mm
	Dot size	0.42 × 0.42 mm
	Size of a standard character	Height 7.2 mm
	Effective display area	117 mm horizontally × 63 mm vertically
	View angle	Up/Down: ± 30° Left/Right: ± 30°
	Display color	White, black 2 color (blue mode)
	Life expectancy (until brightness reduced by half)	50,000 hours minimum
	Contrast adjustment	The contrast can be adjusted with the contrast adjustment on the back of the NT21.
Backlight (white cold cathode tube)	Life expectancy*1	50,000 hours minimum
	Replacement	Not user serviceable
	Brightness adjustment	Not user serviceable
	Automatic turn-OFF function	Can be set to turn OFF in 1 to 255 minutes, or to remain ON
Indicators	RUN	Lit green: Running normally, Memory Unit automatic transmission done Flashing green: Memory Unit automatic transmission being executed, Memory Unit automatic transmission error Lit orange during operation: Low battery voltage (when a battery is installed) Lit red when NT21 is stopped: Low battery voltage (when a battery is installed)

\*1: Time taken for brightness to reduce to half at normal temperature and humidity

### Panel Specifications

Item	Specification	
Touch panel	Type :	Resistive type
	Number of switches:	91 (13 horizontally × 7 vertically)
	Maximum number that can be registered on one screen:	256
	Cell size:	Approx. 9 × 9 mm
	Input:	Pressure-sensitive type
	Operating force:	1 N minimum
	Life expectancy:	One million operations minimum

### External Interface Specifications

Item		Specification
Serial communication	Serial ports A and B	Conforms to EIA RS-232C D-SUB 9-pin connector (female) +5 V output at pin No. 6 (Total output 150 mA max. from ports A and B)
Expansion interface		Dedicated connector

**Note** When using the +5 V output of pin No. 6, check that the total current required by the devices connected to ports A and B is less than 150 mA. The NT21 supplies +5 V ± 5% (150 mA max.) to pin 6 of these ports.

## Programming Environment

Item	Specification
Programming System	Programming Support Software
Programming Device	Programming Support Software: NT-series Support Tool for Windows (Ver. 5), by OMRON

## Special Features

Item	Specifications	
Buzzer	<p>Three kinds of buzzer sound (continuous, short intermittent, and long intermittent)</p> <p>Sounds: On reception of a command from the host, display of a screen with a buzzer setting, or display of an error screen such as for a receive error.</p> <p>Stops: On reception of a command from the host, or display of a screen with no buzzer setting.</p> <p>Setting: Set "ON" for "Buzzer Sound" in the memory switch menu, or set "ERROR ON" for the buzzer to sound only when an error occurs.</p> <p>The buzzer sounds three times in response to prohibited input.</p>	
Touch switch input sound	<p>Touch switches</p> <p>Input sound: Sounding for 0.2 seconds</p> <p>Setting: Set "ON" for "Key Press Sound" in the memory switch menu.</p>	
Maintenance function	<ul style="list-style-type: none"> <li>- Memory switch setting</li> <li>- Self-test functions, such as for the memory and external interface</li> <li>- Setting condition confirmation function</li> <li>- Communication check function</li> <li>- Initialization of internal memory data</li> <li>- Display of display/alarm history data</li> <li>- Registered data test display function</li> </ul>	
Battery backup (optional)	<ul style="list-style-type: none"> <li>- Backup of numeral/character string memory table data in the NT21</li> <li>- Backup of display/alarm history data</li> <li>- Backup of recipe data</li> </ul> <p>Battery life: 5 years (at 25°C)</p> <p>When voltage becomes low: RUN Indicator lights in orange or red The communication flag to the PC (BAT LOW) is turned ON (1).</p>	
Resume function (Operates only when the optional battery is installed.)	<p>Retains the contents of the numeral and character string memory tables (i.e., they are not initialized) when the NT21 is turned ON or the operation mode is changed.</p> <p>Setting: Set "ON" for "Resume Function" in the memory switch menu.</p>	
Calendar and clock function	<ul style="list-style-type: none"> <li>- Displays the date and time read from the PC.</li> <li>- Display the date and time with the "Calendar Check" operation.</li> </ul>	
Programming Console function	<p>Executes functions equivalent to those of a C200H-PRO27-E Programming Console for CPM1, CPM1A, CPM2A, CPM2C, CQM1 (-EV1 only), CQM1H, C200HX/HG/HE(-Z)E, and SRM1 (C02-V2 only) PCs.</p> <p>Executes functions as a Programming Console for CS/CJ-series PC.</p>	
Mathematical function	<p>Up to 256 calculation expressions can be registered along with the screen data. The calculation function reads the required data from the numeral memory table or host words, executes the registered calculations, and writes the results.</p> <p>Arithmetic operators, logic operators, bit operators, and comparative operators can be used.</p>	
Transmission functions	System program transmission	<p>Downloads the system program from the system installer.</p> <p>Downloads/Upload the system program with a Memory Unit.</p>
	Screen data transmission	<ul style="list-style-type: none"> <li>- Function for downloading screen data to and uploading screen data from the NT Support Tool</li> <li>- Function for transmitting screen data to and from the Memory Unit.</li> </ul>
	History data uploading	<p>Function for uploading display/alarm history data from PT.</p>



## Communications Specifications

### Specifications for Host Link Communications

Item	Specification
Communications standard	EIA RS-232C
Communications settings	Start-stop synchronization Baud rate: 9,600 or 19,200 bps Data length: 7 bits Stop bits: 2 bits Parity: Even
Connector	9-pin D-SUB connectors (female) (serial ports A and B)
Number of Units connected	1:1
Transmission distance	Max. 15 m*
Communications protocol	C-series SYSWAY (1:N)

\* When using an NT-AL001 or NS-AL002 Link Adapter, the specifications are as follows:

- RS-232C cable: Max. 2 m (Not required with the NS-AL002)
- RS-422A cable: Total length 500 m max.

### Specifications for 1:1 NT Link Communications

Item	Specification
Communications standard	EIA RS-232C
Connector	9-pin D-SUB connectors (female) (serial ports A and B)
Number of Units connected	1:1
Transmission distance	Max. 15 m*

\* When using an NT-AL001 or NS-AL002 Link Adapter, the specifications are as follows:

- RS-232C cable: Max. 2 m (Not required with the NS-AL002)
- RS-422A cable: Total length 500 m max.

### Specifications for 1:N NT Link Communications

Item	Specification
Communications standard	EIA RS-232C
Connector	9-pin D-SUB connectors (female) (serial ports A and B)
Number of Units connected	1:1 to 8
Transmission distance	Max. 15 m*

\* NT-AL001 or NS-AL002 Link Adapters are required to connect two or more PTs. When using Link Adapters, the specifications are as follows:

- RS-232C cable: Max. 2 m (Not required with the NS-AL002)
- RS-422A/485 cable: Total length 500 m max.

## Specifications for High-speed 1:N NT Link Communications

Item	Specification
Communications standard	EIA RS-232C
Connector	9-pin D-SUB connectors (female) (serial ports A and B)
Number of Units connected	1:1 to 8
Transmission distance	Max. 15 m*

\* NT-AL001 or NS-AL002 Link Adapters are required to connect two or more PTs. When using Link Adapters, the specifications are as follows:

- RS-232C cable: Max. 2 m (Not required with the NS-AL002)
- RS-422A/485 cable: Total length 500 m max.

## Specifications for Memory Link Communications

Item	Specification
Communications standard	EIA RS-232C
Communications settings	Start-stop synchronization Baud rate: 1,200, 2,400, 4,800, 9,600, 19,200, or 38,400 bps Data length: 7, 8 bits Stop bits: 1, 2 bits Parity: None, even, odd Flow control: None, RS/CS, XON/XOFF Response: Presence/absence
Connector	9-pin D-SUB connectors (female) (serial ports A and B)
Number of Units connected	1:1
Transmission distance	Max. 15 m*
Communications protocol	Memory link

\* When using NT-AL001 or NS-AL002 Link Adapter, specifications are as follows:

- RS-232C: Max. 2 m (Not required with the NS-AL002)
- RS-422A: Max. total length 500 m

## Specifications for Bar Code Reader Communications

Item	Specification
Communications standard	EIA RS-232C
Communications settings	Start-stop synchronization Baud rate: 4,800, 9,600, or 19,200 bps Data length: 7, 8 bits Stop bits: 1, 2 bits Parity: None, even, odd Flow control: RS/CS
Connector	9-pin D-SUB connector (female) (serial port A)
Number of Units connected	1:1
Transmission distance	Max. 15 m
Communications protocol	Non-protocol mode
Data format	[STX] Data (0 to 40 bytes) [ETX]

# Appendix B

## External Dimensions and Mounting Dimensions

PTs

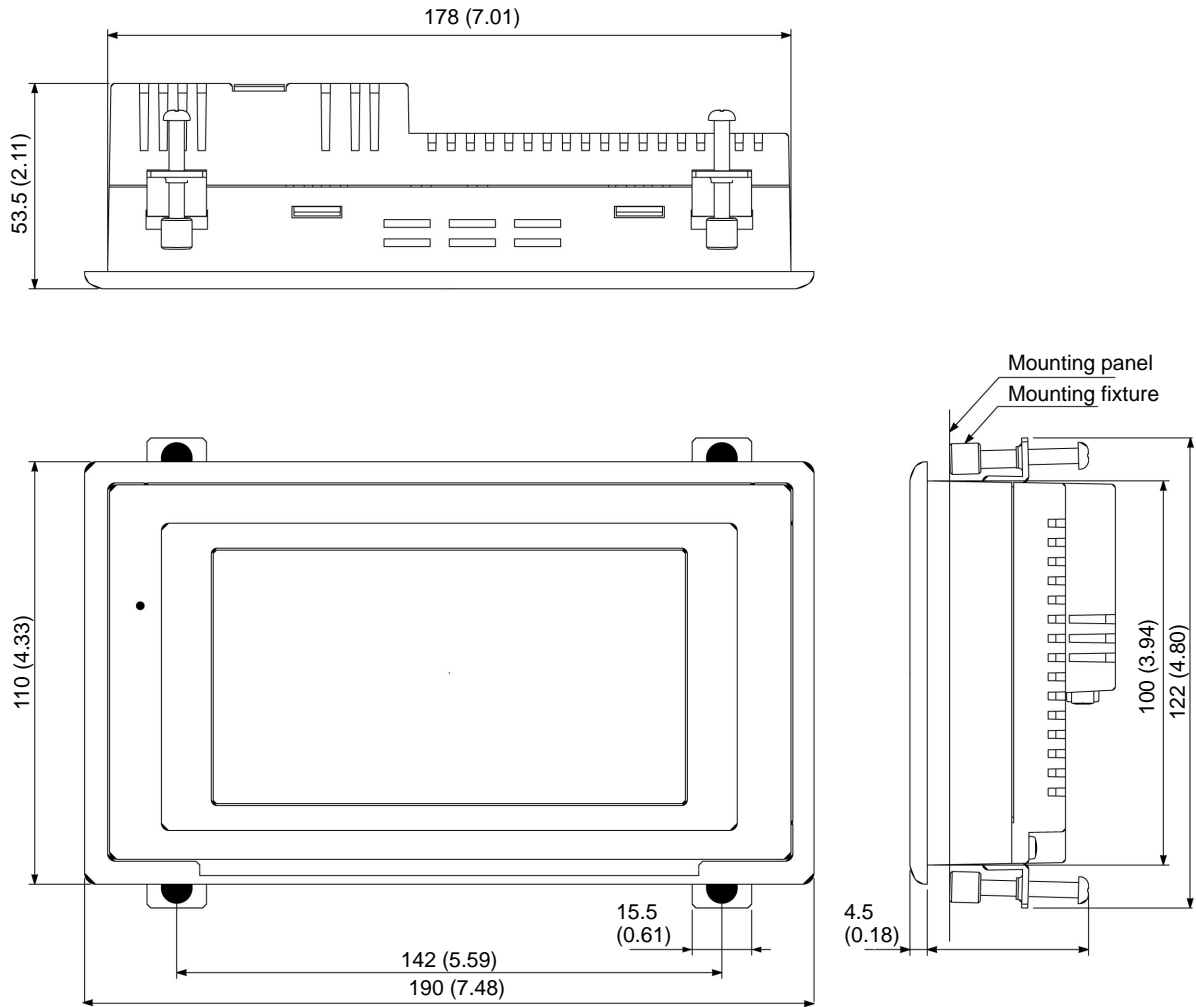

Units: mm (inch)

### Cable Connection Dimensions

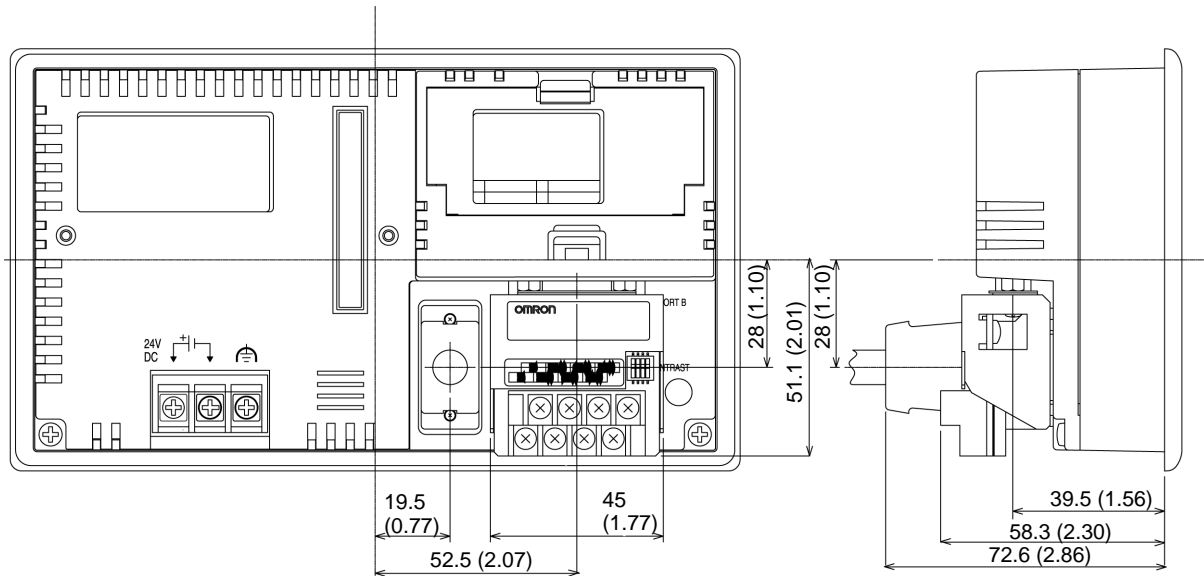

Units: mm (inch)

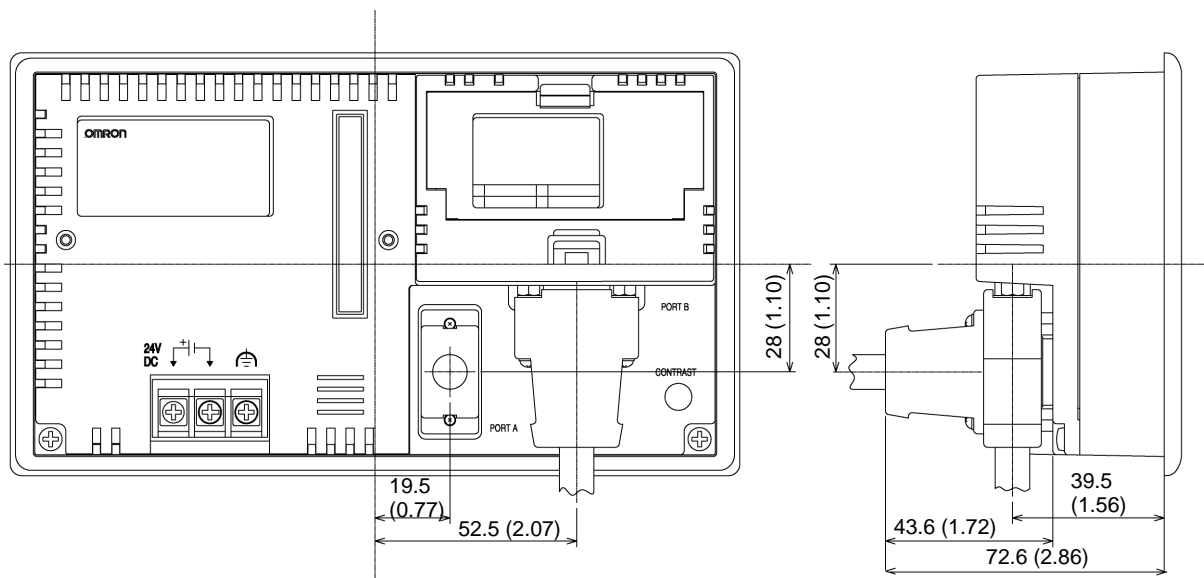

Units: mm (inch)

## **Appendix C**

### **Transporting and Storing the NT21**

- When transporting the NT21, use the packaging intended for it.
- When storing the NT21, observe the following conditions.

Storage ambient temperature: -20 to 70°C

Storage ambient humidity:	0 to 40°C:	85%
	40 to 50°C:	55%
	50 to 70°C:	23%

# Appendix D

## Making the Cable

The procedure for making up the cable is described below.

Also refer to this procedure for making a connecting cable for use with RS-422A/485 type connections.

### Cable Preparation

The preparation of the cable differs according to whether or not the shielding wire is to be connected to the FG.

#### Cable with Shield Connected to FG

- 1, 2, 3...**
1. Cut the cable to the required length.
  2. Remove the external vinyl insulation from the cable with a razor blade. Take care not to damage the shielding underneath.
  3. Cut back the shielding wire with scissors.
  4. Use wire strippers to strip the insulation from each wire.
  5. Fold back the shielding wire.
  6. Wrap aluminum foil tape around the folded-back shielding wire.

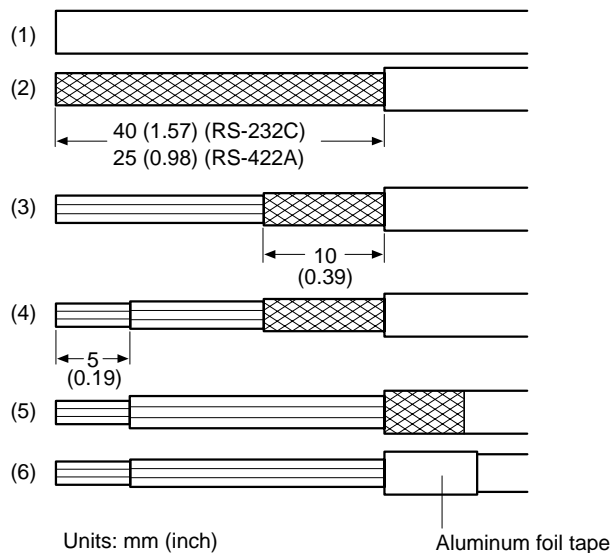

#### Cable with Shield Not Connected to FG

- 1, 2, 3...**
1. Cut the cable to the required length.
  2. Remove the external vinyl insulation from the cable with a razor blade. Take care not to damage the shielding underneath.
  3. Cut back the shielding wire with scissors.
  4. Use wire strippers to strip the insulation from each wire.

5. Wrap vinyl tape over the cut off end of the shielding wire.

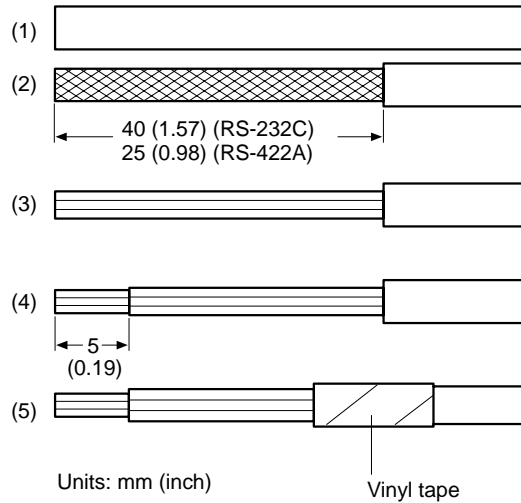

## Soldering

- 1, 2, 3...
1. Slide heat-shrink tube over each wire.
  2. Pre-solder each wire and connector terminal.
  3. Solder each wire to each connector terminal.

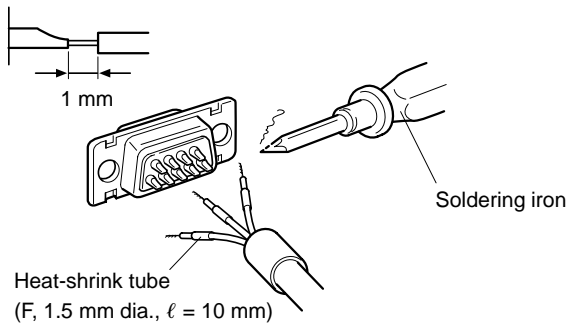

4. Push the heat shrink tube over the soldered joint and heat the tube to shrink it in place.

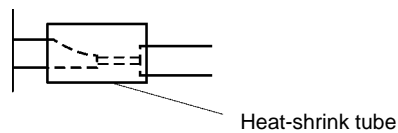

## Hood Assembly

Assemble the connector hood as shown below.

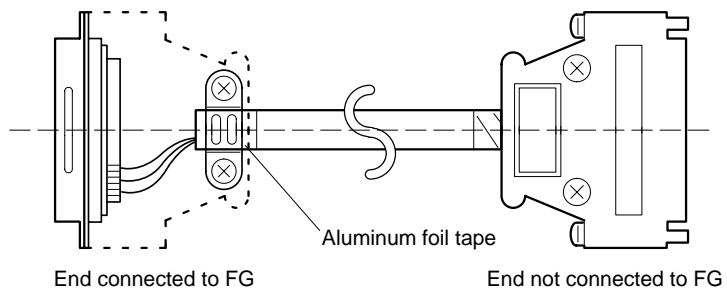

# Appendix E

## Making the Cable for Connecting a Personal Computer

Refer to the following when making a cable for connecting the NT Support Tool.

### Assembly of Connecting Cables

Wiring should be carried out in one of the following ways, depending on the type of RS-232C connector.

#### 25-pin Connector

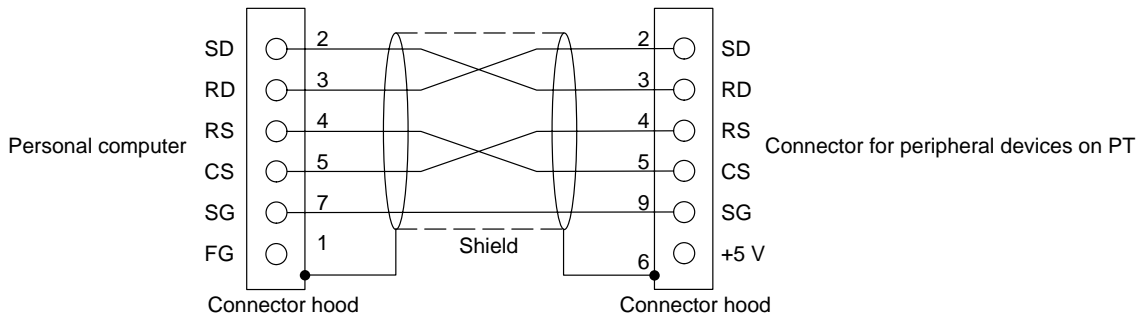

Use the following recommended products when making the connecting cable.

Name	Model	Remarks
Connector	XM2D-2501	25-pin, made by OMRON, for personal computer side
	XM2A-0901	9-pin, made by OMRON, for PT side
Connector hood	XM2S-2511	25-pin, made by OMRON, for personal computer side
	XM2S-0911	9-pin, made by OMRON, for PT side
Connector set	XM2S-0911-S003	9-pin, made by OMRON, for PT side Connector and Connector hood
Cable	AWG28 × 5P IFVV-SB	Multi-core shielded cable, made by Fujikura Ltd.
	CO-MA-VV-SB 5P × 28AWG	Multi-core shielded cable, made by Hitachi Cable, Ltd.



### 9-pin Connector

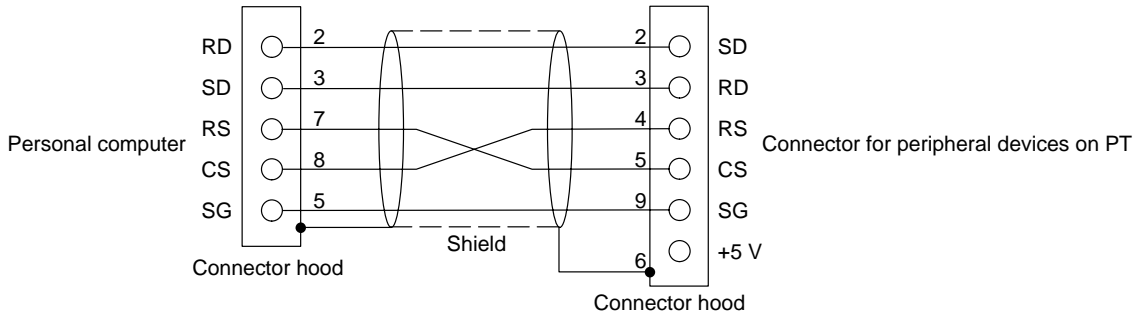

Use the following recommended products when making the connecting cable.

Name	Model	Remarks
Connector	XM2D-0901	9-pin, made by OMRON, for personal computer
	XM2A-0901	9-pin, made by OMRON, for PT
Connector hood*	XM2S-0911	9-pin, mm pitch screw, made by OMRON
	XM2S-0913	9-pin, inch pitch screw, made by OMRON
Connector set	XM2S-0911-S003	9-pin, made by OMRON, for PT side Connector and Connector hood
Cable	AWG28 × 5P IFVV-SB	Multi-core shielded cable, made by Fujikura Ltd.
	CO-MA-VV-SB 5P × 28AWG	Multi-core shielded cable, made by Hitachi Cable, Ltd.

\* One XM2S-0911 (for PT) and either one XM2S-0911 or -0913 (for your personal computer) are needed.

# Appendix F

## Model List

### PTs

Model	Specification
NT21-ST121-E	STN monochrome display, beige
NT21-ST121B-E	STN monochrome display, black

### Host Link Units

Model	Specification	Applicable PC
C200H-LK201-V1	Rack-mounting Unit with RS-232C connector for C200H	C-series C200HS C200HX/HG/HE(-Z)E
C200H-LK202-V1	Rack-mounting Unit with RS-422A connector for C200H	
CV500-LK201	Features an RS-232C connector and a selectable RS-232C/RS-422A connector Rack-mounting Unit for CVM1/CV	CVM1/CV-series CV500 CV1000 CV2000 CVM1

### CompoBus/S Master Control Unit

Model	Specification	Model Name
SRM1-C02-V2	Features an RS-232C port	SRM1

### Communications Unit

Model	Specification	Applicable PC
CS1W-SCU21	RS-232C (2 ports) Rack-mounting Unit	CS-series CS1G/H, CS1G/H-H
CJ1W-SCU41	Features an RS-422A/485 port (port 1) and an RS-232C port (port 2).	CJ-series CJ1G

### CPU Units for Connection via Host Link

Model	Specification	PC Type
CPM1-10CDR-□ CPM1-20CDR-□ CPM1-30CDR-□ CPM1A-10CD□-□ CPM1A-20CD□-□ CPM1A-30CD□-□ CPM1A-40CD□-□	RS-232C adapter/RS-422A adapter connected to the peripheral port	C-series CPM1
CPM2A-30CD□□-□ CPM2A-40CD□□-□ CPM2A-60CD□□-□	Features a 9-pin connector for RS-232C connections	C-series CPM2A
CPM2C-10□□□□□□-□ CPM2C-20□□□□□□-□	The PC's communications connector can be split into an RS-232C port and peripheral port with a CPM2C-CN111 Connecting Cable. (The CS1W-CN114/118 Connecting Cables convert the connector to a single RS-232C or peripheral port.)	C-series CPM2C

Model	Specification	PC Type
CQM1-CPU21-E CQM1-CPU41-EV1 CQM1-CPU42-EV1 CQM1-CPU43-EV1 CQM1-CPU44-EV1 CQM1-CPU45-EV1	Features a 9-pin connector for RS-232C connections	C-series CQM1
CQM1H-CPU11 CQM1H-CPU21 CQM1H-CPU51 CQM1H-CPU61	Features a 9-pin connector for RS-232C connections (The CQM1H-CPU11-E has only a peripheral port.)	C-series CQM1H
C200HS-CPU21-E C200HS-CPU23-E C200HS-CPU31-E C200HS-CPU33-E	Features a connector for RS-232C connections (selectable/9-pin)	C-series C200HS
C200HE-CPU32-(Z)E(*) C200HE-CPU42-(Z)E	Features a connector for RS-232C connections (selectable/9-pin)	C-series C200HE(-Z)E
C200HG-CPU33-(Z)E(*) C200HG-CPU43-(Z)E C200HG-CPU53-(Z)E(*) C200HG-CPU63-(Z)E	Features a connector for RS-232C connections (selectable/9-pin)	C-series C200HG(-Z)E
C200HX-CPU34-(Z)E(*) C200HX-CPU44-(Z)E C200HX-CPU54-(Z)E(*) C200HX-CPU64-(Z)E C200HX-CPU65-ZE C200HX-CPU85-ZE	Features a connector for RS-232C connections (selectable/9-pin)	C-series C200HX(-Z)E
CS1G-CPU42-E(V1) CS1G-CPU43-E(V1) CS1G-CPU44-E(V1) CS1G-CPU45-E(V1)	Features a connector for RS-232C connections (9-pin)	CS-series CS1G
CS1H-CPU63-E(V1) CS1H-CPU64-E(V1) CS1H-CPU65-E(V1) CS1H-CPU66-E(V1) CS1H-CPU67-E(V1)	Features a connector for RS-232C connections (9-pin)	CS-series CS1H
CS1G-CPU42H CS1G-CPU43H CS1G-CPU44H CS1G-CPU45H	Features a connector for RS-232C connections (9-pin)	CS-series, high-speed CS1G-H
CS1H-CPU63H CS1H-CPU64H CS1H-CPU65H CS1H-CPU66H CS1H-CPU67H	Features a connector for RS-232C connections (9-pin)	CS-series, high-speed CS1H-H
CJ1G-CPU44 CJ1G-CPU45	Features a connector for RS-232C connections (9-pin)	CJ-series CJ1G
CVM1-CPU01-EV2 CVM1-CPU11-EV2 CVM1-CPU21-EV2	Features a connector for RS-232C connections (selectable/9-pin)	CVM1/CV-series CVM1

\* One of the Serial Communications Boards C200HW-COM02/COM04/COM05/COM06-EV1 is required.

## CPU Units for Connection via 1:1 NT Link

Model	Specification	PC Type
CPM1-10CDR-□ CPM1-20CDR-□ CPM1-30CDR-□ CPM1A-10CD□-□ CPM1A-20CD□-□ CPM1A-30CD□-□ CPM1A-40CD□-□	RS-232C adapter connected to the peripheral port (RS-422A adapter cannot be used)	C-series CPM1
CPM2A-30CD□□-□ CPM2A-40CD□□-□ CPM2A-60CD□□-□	Features a 9-pin connector for RS-232C connections	C-series CPM2A
CPM2C-10□□□□□□-□ CPM2C-20□□□□□□-□	Connect to the RS-232C port of a CPM2C-CN111 Connecting Cable.	C-series CPM2C
CQM1-CPU41-EV1 CQM1-CPU42-EV1 CQM1-CPU43-EV1 CQM1-CPU44-EV1 CQM1-CPU45-EV1	Features a 9-pin connector for RS-232C connections	C-series CQM1
CQM1H-CPU21 CQM1H-CPU51 CQM1H-CPU61	Features a 9-pin connector for RS-232C connections	C-series CQM1H
C200HS-CPU21-E C200HS-CPU23-E C200HS-CPU31-E C200HS-CPU33-E	Features a connector for RS-232C connections (selectable/9-pin)	C-series C200HS
C200HE-CPU32-(Z)E <sup>(*)</sup> C200HE-CPU42-(Z)E	Features a connector for RS-232C connections (selectable/9-pin)	C-series C200HE(-Z)E
C200HG-CPU33-(Z)E <sup>(*)</sup> C200HG-CPU43-(Z)E C200HG-CPU53-(Z)E <sup>(*)</sup> C200HG-CPU63-(Z)E	Features a connector for RS-232C connections (selectable/9-pin)	C-series C200HG(-Z)E
C200HX-CPU34-(Z)E <sup>(*)</sup> C200HX-CPU44-(Z)E C200HX-CPU54-(Z)E <sup>(*)</sup> C200HX-CPU64-(Z)E C200HX-CPU65-ZE C200HX-CPU85-ZE	Features a connector for RS-232C connections (selectable/9-pin)	C-series C200HX(-Z)E
CVM1-CPU01-EV2 CVM1-CPU11-EV2 CVM1-CPU21-EV2	Features a connector for RS-232C connections (selectable/9-pin)	CVM1/CV-series CVM1

\* One of the Serial Communications Boards C200HW-COM02/COM04/COM05/COM06-EV1 is required.

## CPU Units for Connection via 1:N NT Link

Model	Specification	PC Type
CQM1H-CPU51 <sup>(*)</sup> CQM1H-CPU61 <sup>(*)</sup>	Features a 9-pin connector for RS-232C connections	C-series CQM1H
C200HE-CPU32-(Z)E <sup>(*)</sup> C200HE-CPU42-(Z)E	Features a connector for RS-232C connections (selectable/9-pin)	C-series C200HE(-Z)E
C200HG-CPU34-(Z)E <sup>(*)</sup> C200HG-CPU43-(Z)E C200HG-CPU53-(Z)E <sup>(*)</sup> C200HG-CPU63-(Z)E	Features a connector for RS-232C connections (selectable/9-pin)	C-series C200HG(-Z)E

Model	Specification	PC Type
C200HX-CPU34-(Z)E(*) C200HX-CPU44-(Z)E C200HX-CPU54-(Z)E(*) C200HX-CPU64-(Z)E C200HX-CPU65-ZE C200HX-CPU85-ZE	Features a connector for RS-232C connections (selectable/9-pin)	C-series C200HX(-Z)E
CS1G-CPU42-E(V1) CS1G-CPU43-E(V1) CS1G-CPU44-E(V1) CS1G-CPU45-E(V1)	Features a connector for RS-232C connections (9-pin)	CS-series CS1G
CS1H-CPU63-E(V1) CS1H-CPU64-E(V1) CS1H-CPU65-E(V1) CS1H-CPU66-E(V1) CS1H-CPU67-E(V1)	Features a connector for RS-232C connections (9-pin)	CS-series CS1H
CS1G-CPU42H CS1G-CPU43H CS1G-CPU44H CS1G-CPU45H	Features a connector for RS-232C connections (9-pin)	CS-series, high-speed CS1G-H
CS1H-CPU63H CS1H-CPU64H CS1H-CPU65H CS1H-CPU66H CS1H-CPU67H	Features a connector for RS-232C connections (9-pin)	CS-series, high-speed CS1H-H
CJ1G-CPU44 CJ1G-CPU45	Features a connector for RS-232C connections (9-pin)	CJ-series CJ1G

\*1: A CQM1H-SCB41 Serial Communications Board is required.

\*2: One of the Serial Communications Boards C200HW-COM02/COM04/COM05/COM06-EV1 is required.

## CPU Units for Connection via High-speed 1:N NT Link

Model	Specification	PC Type
CS1G-CPU42-E(V1) CS1G-CPU43-E(V1) CS1G-CPU44-E(V1) CS1G-CPU45-E(V1)	Features a 9-pin connector for RS-232C connections	CS-series CS1G
CS1H-CPU63-E(V1) CS1H-CPU64-E(V1) CS1H-CPU65-E(V1) CS1H-CPU66-E(V1) CS1H-CPU67-E(V1)	Features a 9-pin connector for RS-232C connections	CS-series CS1H
CS1G-CPU42H CS1G-CPU43H CS1G-CPU44H CS1G-CPU45H	Features a connector for RS-232C connections (9-pin)	CS-series, high-speed CS1G-H
CS1H-CPU63H CS1H-CPU64H CS1H-CPU65H CS1H-CPU66H CS1H-CPU67H	Features a connector for RS-232C connections (9-pin)	CS-series, high-speed CS1H-H
CJ1G-CPU44 CJ1G-CPU45	Features a connector for RS-232C connections (9-pin)	CJ-series CJ1G

**Reference:** Serial Communications Boards (CS1W-SCB41) and Serial Communications Units (CS1W-SCU21) with lot number 991220 (12/20/99) and later support the high-speed 1:N NT Link. Boards and Units with earlier lot numbers **cannot** be used to establish a high-speed 1:N NT Link.

## Link Adapters (RS-232C/RS-422A)

Model	Specification
NT-AL001	RS-232C: 9-pin connector RS-422A/485: 8-pin terminal block Note: The RS-232C connector is insulated from the RS-422A/485 terminal block.
NS-AL002	RS-232C: 9-pin connector (This connector can be connected directly to serial port B on the NT21.) RS-422A/485: 8-pin terminal block Note: The RS-232C connector is <b>not</b> insulated from the RS-422A/485 terminal block.

## RS-232C Adapter and RS-422A Adapter

Model	Specification
CPM1-CIF01	Links the RS-232C port of a NT21 and the peripheral port of a CPM1, CPM2A, CPM2C, SRM1 (compatible with host link, and NT Link (1:1))
CPM1-CIF11	Links the RS-422A port of a Link Adapter and the peripheral port of a CPM1, CPM2A, CPM2C, SRM1 (compatible with host link)

## Related Parts and Equipment for PT

Name	Model	Remark
NT Support Tool*	NT-ZJCAT1-EV5	Compatible with PC/AT personal computers For Windows 95/98/NT (English version) CD-ROM
Options	NT20S-KBA04	Reflection-suppressing protective sheet for NT21
	NT20S-KBA01	Chemical-resistant cover for NT21
	NT-MF261	Memory Unit for NT21
	3G2A9-BAT08	Spare battery

\* The system installer and the NT21 system program (Ver. 1) are included with the NT Support Tool.

## Appendix G Option List

### Protective Sheets ... NT20S-KBA04

Attached to the display to prevent irregular reflection or contamination. The entire sheet is colorless and transparent. The five sheets make a set.

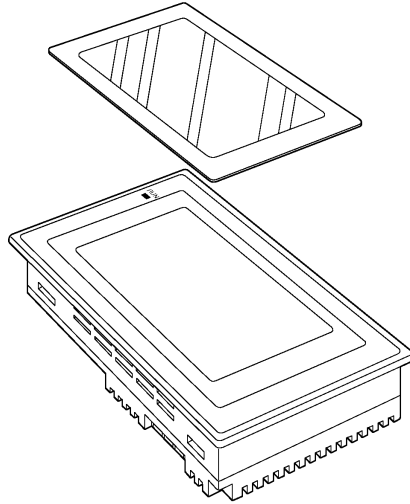

### Chemical-resistant Covers ... NT20S-KBA01

Covers the front panel and protects it from various chemical agents. The entire sheet is milky white and made of silicone rubber.

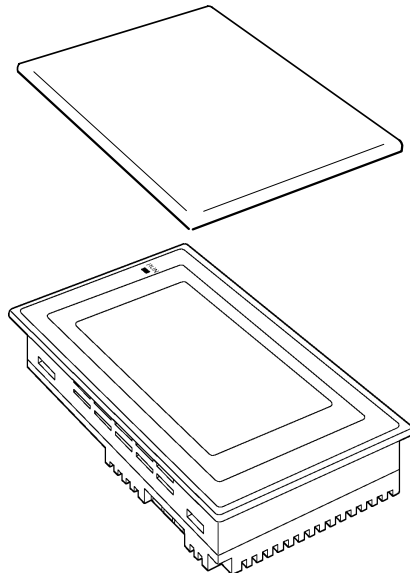

The sheet offers protection against the following chemical agents.

Protects against	Does not protect against
Boric acid	Hexane
Sulfuric acid	Lubricating oil
Nitrogen	Benzene
Ammonia gas	Butane
Carbonic acid gas	Carbonic acid
Phenol	Chlorinated solvents
Glycerin	Naphthalene
Ammonia water	Soy bean oil
Calcium chloride	Toluene
Developing fluid (hypo)	
Acetaldehyde	
Lard	

For information on chemical agents not listed in the table above, please inquire whether or not protection is offered (if the chemical agent is one against which silicone rubber is recognized as offering protection, please use this product even if the agent is not listed in the “Protects against” column of the table above).

### Replacement Battery ... 3G2A9-BAT08

This is a lithium battery used for memory backup.

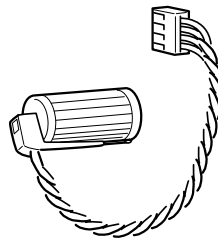

**Note** Dispose of any battery that has been dropped on the floor or otherwise subjected to excessive shock. Batteries that have been subjected to shock may leak if they are used.

### Memory Unit ... NT-MF261

This is a special unit for reading/writing the screen data and the system programs in an NT21. Data is transmitted by DIP switch setting at the Memory Unit.

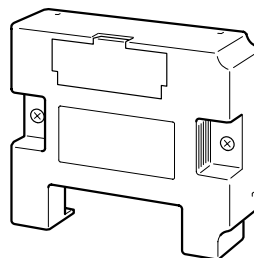



# Index

## Numbers

- 1:N connection among RS-422A ports, 89
- 1:N connection to the host's RS-485 port, 92
- 1:N connection using the host's RS-232C port, 95

## A

- Allowable power supply voltage range, 187
- Automatic transmission (Memory Unit), 33

## B

- bar code reader, connecting, 29
- Battery cover, 14
- Before operating, 7
- Brightness adjustment, 188

## C

- Cable connection dimensions, 194
- Calling the System Installer mode, 118
- Calling the System Menu, 108
- Cell size (Touch panel), 188
- Changing the system settings, 120
- Checking communication at serial ports, 163
- Checking communication with the NT Support Tool, 162
- Checking interfaces, 161
- Checking screen data, 153
- Checking the backlight, 158
- Checking the battery voltage, 160
- Checking the buzzer, 157
- Checking the LCD (screen display), 158
- Checking the PT setting status, 149
- Checking the RUN Indicator, 158
- Checking touch switches, 160
- Chemical-resistant cover, 207
- Cleaning method, 185
- Clearing screen data, 110, 121
- Clearing/installing the system program, 119
- clock, displaying the date and time, 147
- Comm. A Method, 125
- Comm. B Method, 125

- Communication Board, 41, 51, 55, 60, 70
- Communication Boards, 78
- Communication condition, 125
- Communication condition settings for bar code readers, 144
- Communication condition settings for the host link method, 125
- Communication errors and their remedies, 181
- Communication method for communications with the host, 125
- Communication method settings, 126
- Communication methods, 10
- Communication port, 10
- Communication type, 10
- Communication Unit, 201
- Communications specifications, 190
- Connecting a bar code reader, 29
- Connecting directly between RS-232C ports, 63
- Connecting the NT Support Tool, 28
- Connection method, 10
- CPU, 70
- CPUs, 51, 55, 60, 78, 80
- CPUs (for connection via a host link), 201
- CPUs connectable with Host Link Units or Expansion Communication Board, 70

## D

- Device check, 156
- Dimensions, 187
- Disabling/enabling System Menu display, 120
- Disabling/enabling writing to the screen data memory, 120
- Display, 13
- Display color, 188
- Display device, 188
- Display specifications, 188
- Displaying and printing the display history record, 150
- Displaying the calendar and clock, 147
- Downloading the system program, 120

## E

- Effective display area, 188
- Enclosure ratings, 187
- Error messages, 176
- Errors in the system installer mode and their remedies, 181

Errors occurring at start of operation, 177  
Errors occurring during operation, 179  
Errors occurring on screen data initialization and transmission,  
180  
Errors when using a Memory Unit, 36  
Expansion interface connector, 14  
Expansion Mode, 106  
External interface specifications, 188, 189

## **F-H**

Functional ground terminal, 18  
General specifications, 187  
GR terminal, 14  
Grounding, 18, 187  
Host link method, 40, 69  
Host Link Unit, 41  
Host link unit, 201

## **I**

Initializing alarm history record data, 113  
Initializing display history record data, 112  
Initializing the memory switches, 116  
Initializing the memory tables, 114  
Initializing the recipe tables, 117  
Inspection method, 185  
Installation environment, 16  
Installation in the operation panel, 16

## **L-M**

Life expectancy (backlight), 188  
Life expectancy (display panel), 188  
Life expectancy (touch panel), 188  
Link Adapters, RS-232C/RS-422A, 205  
maintenance, 173  
Maintenance Mode, 106  
Making the cable, 197  
Making the cable for connecting a PC, 199  
Manual transmission (Memory Unit), 35  
Manuals, 8  
Memory initialization, 110  
Memory link method, 63, 85  
Memory switch, 125  
Memory switch setting screen, 134

Memory Unit  
errors, 36  
usage, 31  
Memory unit, 208  
Menu tree, 107  
RUN mode, 105  
System Installer Mode, 105

## **N**

Noise resistance, 187  
NT Link  
1:1 NT Link, 51  
1:N NT Link, 55, 80  
high-speed 1:N NT Link, 60, 83  
setting 1:1 NT Link communications conditions, 129  
setting 1:N NT Link communications conditions, 129  
NT Support Tool, 205  
Connecting, 28  
Number of dots, 188  
Number of switches (touch panel), 188

## **O**

Operating ambient humidity, 187  
Operating ambient temperature, 187  
Operating environment, 187  
Operating force, 188  
Operation at startup, 104  
Operation modes, 105

## **P**

Peripheral devices that can be connected, 6  
Power consumption, 187  
Power input terminals, 14  
Power supply connection, 17  
precautions, xi  
Precautions to be observed when transmitting screen data, 124  
Programming Console function, 165  
Programming environment, 189  
Protective sheet, 207  
PT, 201

## **R**

Rated power supply voltage, 187  
Relationships among modes, 105  
Replacement battery, 208

Replacing the battery, 184  
RS-232C adaptor, 205  
RS-422A adaptor, 205  
RS-232C/RS-422A Link Adapter, 205  
RUN, 105  
RUN Indicator, 13

## **S**

Screen data composition and transmission units, 123  
Screen data memory check, 159  
Screen Saver function, 138  
Selecting menu items, 108  
Serial Communication Board, 40, 55, 60, 69, 83  
Serial Communication Unit, 40  
Serial port A, 7, 10  
Serial port A connector, 14  
Serial port B, 7, 10  
Serial port B connector, 14  
Set, 128  
Setting "Screen Saver Movement", 138  
Setting the "Start-up Wait Time", 136  
Setting the 1:1 NT Link method, 129  
Setting the 1:N NT Link method, 129  
Setting the automatic reset function, 141  
Setting the bar code reader input function, 144  
Setting the "Buzzer Sound", 137  
Setting the conditions for communications with the memory link method, 126  
Setting the history display method, 139

Setting the host link method, 127  
Setting the "Key Press Sound", 136  
Setting the Memory Link Method, 132  
Setting the resume function, 140  
Setting the retry count, 142  
Setting the time-out interval, 142  
Shock resistance (operating), 187  
Special features, 189  
Starting operation, 133  
Starting the NT21, 104  
Storage ambient temperature, 187  
Support Tool, 205  
    Connecting the NT Support Tool, 28  
Switching from the System Menu to the RUN mode, 109  
Switching to the RUN mode, 133  
System configuration, 6  
System Menu, 105  
    calling, 108  
    operation, 101

## **T-W**

Transmit Mode, 106  
Transmitting the screen data, 123  
Transporting and storing the NT31/NT31C, 195  
troubleshooting, 173  
Usable systems (Programming Console function), 167  
Using a Memory Unit, 31  
Vibration resistance (operating), 187  
View angle, 188  
Weight, 187

## Revision History

A manual revision code appears as a suffix to the catalog number on the front cover of the manual.

Cat. No. V068-E1-01

↑  
Revision code

The following table outlines the changes made to the manual during each revision. Page numbers refer to the previous version.

Revision code	Date	Revised content
1	October 2001	Original production

**OMRON CORPORATION**

FA Systems Division H.Q.

66 Matsumoto

Mishima-city, Shizuoka 411-8511

Japan

Tel: (81)559-77-9181/Fax: (81)559-77-9045

**Regional Headquarters**

**OMRON EUROPE B.V.**

Wegalaan 67-69, NL-2132 JD Hoofddorp

The Netherlands

Tel: (31)2356-81-300/Fax: (31)2356-81-388

**OMRON ELECTRONICS LLC**

1 East Commerce Drive, Schaumburg, IL 60173

U.S.A.

Tel: (1)847-843-7900/Fax: (1)847-843-8568

**OMRON ASIA PACIFIC PTE. LTD.**

83 Clemenceau Avenue,

#11-01, UE Square,

Singapore 239920

Tel: (65)835-3011/Fax: (65)835-2711

# OMRON

**Authorized Distributor:**