

Switch Mode Power Supply S82J (10/25/50/100/150/300/600-W Models)

Low-cost Global Power Supply with CE Marking

- Safety standards:
UL: UL508, No.60950-1 Class 2,
CSA: cUL: C22.2 No. 14, cUR: 60950-1 Class 2,
EN60950-1 (=VDE0805 Teil 1), EN50178 (=VDE0160)
- EMC: Conforms to EN61204-3 Class A
- Mounting bracket available for standard models
Front-mounting bracket type
DIN Rail mounting type (except 300 W and 600 W)

Note: Refer to *Precautions for Safe Use* on page 17.



Model Number Structure

■ Model Number Legend

Note: Not all combinations are possible. Please refer to the list of models in *Ordering Information* on pages 2 and 3.

S82J -

1 2 3 4

1. Power Ratings

010: 10 W
025: 25 W
050: 50 W
100: 100 W
150: 150 W
300: 300 W
600: 600 W

2. Output Voltage

05: 5 V
12: 12 V
15: 15 V
24: 24 V

3. Configuration

10-/25-/50-/100-/150-W models
A: Open-frame type, front terminals
D: Covered type, front terminals

Mounting bracket

None: With mounting bracket
N: Without mounting bracket

4. Mounting Bracket

None: Front-mounting bracket type
D: DIN Rail mounting bracket type

Ordering Information

■ List of Models

Note: For details on normal stock models, contact your nearest OMRON representative.

Front-mounting Bracket Type

Configuration	Input Voltage	Power ratings	Output voltage	Output current	Front-mounting bracket types (Front terminals)	
Open-frame type	100 to 240 VAC (free)	10 W	5 V	2 A	S82J-01005A	
			12 V	1 A	S82J-01012A	
			15 V	0.7 A	S82J-01015A	
			24 V	0.5 A	S82J-01024A	
		25 W	5 V	5 A	S82J-02505A	
			12 V	2.1 A	S82J-02512A	
			15 V	1.7 A	S82J-02515A	
			24 V	1.1 A	S82J-02524A	
		50 W	5 V	10 A	S82J-05005A	
			12 V	4.2 A	S82J-05012A	
			24 V	2.1 A	S82J-05024A	
		100 or 200 VAC (selected automatically)	100 W	5 V	20 A	S82J-10005A
	12 V			8.5 A	S82J-10012A	
	15 V			7 A	S82J-10015A	
	24 V			4.5 A	S82J-10024A	
	100 to 240 VAC (free)	150 W	24 V	6.5 A	S82J-15024A	
	100 or 200 VAC (selected automatically)					
Covered type	100 to 240 VAC (free)	10 W	5 V	2 A	S82J-01005D	
			12 V	1 A	S82J-01012D	
			15 V	0.7 A	S82J-01015D	
			24 V	0.5 A	S82J-01024D	
		25 W	5 V	5 A	S82J-02505D	
			12 V	2.1 A	S82J-02512D	
			15 V	1.7 A	S82J-02515D	
			24 V	1.1 A	S82J-02524D	
		50 W	5 V	10 A	S82J-05005D	
			12 V	4.2 A	S82J-05012D	
			24 V	2.1 A	S82J-05024D	
		100 or 200 VAC (selected automatically)	100 W	5 V	20 A	S82J-10005D
				12 V	8.5 A	S82J-10012D
				15 V	7 A	S82J-10015D
				24 V	4.5 A	S82J-10024D
		100 to 240 VAC (free)	150 W	24 V	6.5 A	S82J-15024D
	100 or 200 VAC (selected automatically)					
	100 or 200 VAC (selectable)	300 W	24 V	14 A	S82J-30024	
				27 A	S82J-30024N	
		600 W	27 A	S82J-60024		
S82J-60024N						

DIN Rail Mounting Bracket Type

Configuration	Input Voltage	Power ratings	Output voltage	Output current	DIN Rail mounting bracket types (Front terminals)
Open-frame type	100 to 240 VAC (free)	10 W	5 V	2 A	S82J-01005AD
			12 V	1 A	S82J-01012AD
			15 V	0.7 A	S82J-01015AD
			24 V	0.5 A	S82J-01024AD
		25 W	5 V	5 A	S82J-02505AD
			12 V	2.1 A	S82J-02512AD
			15 V	1.7 A	S82J-02515AD
			24 V	1.1 A	S82J-02524AD
		50 W	5 V	10 A	S82J-05005AD
			12 V	4.2 A	S82J-05012AD
			24 V	2.1 A	S82J-05024AD
		100 or 200 VAC (selected automatically)	100 W	5 V	20 A
	12 V			8.5 A	S82J-10012AD
	15 V			7 A	S82J-10015AD
	24 V			4.5 A	S82J-10024AD
	100 to 240 VAC (free)	150 W	24 V	6.5 A	S82J-15024AD
100 or 200 VAC (selected automatically)					
Covered type	100 to 240 VAC (free)	10 W	5 V	2 A	S82J-01005DD
			12 V	1 A	S82J-01012DD
			15 V	0.7 A	S82J-01015DD
			24 V	0.5 A	S82J-01024DD
		25 W	5 V	5 A	S82J-02505DD
			12 V	2.1 A	S82J-02512DD
			15 V	1.7 A	S82J-02515DD
			24 V	1.1 A	S82J-02524DD
		50 W	5 V	10 A	S82J-05005DD
			12 V	4.2 A	S82J-05012DD
			24 V	2.1 A	S82J-05024DD
		100 or 200 VAC (selected automatically)	100 W	5 V	20 A
	12 V			8.5 A	S82J-10012DD
	15 V			7 A	S82J-10015DD
	24 V			4.5 A	S82J-10024DD
	100 to 240 VAC (free)	150 W	24 V	6.5 A	S82J-15024DD
100 or 200 VAC (selected automatically)					

Specifications

■ Ratings/Characteristics

Power ratings (See note 1.)		100 to 240 V (Free)				100/200 (Selected automatically)		100/200 (Selected)		
		10 W	25 W	50 W	100 W (24 V)	100 W (5 V, 12 V, 15 V)	150 W	300 W	600 W	
Efficiency (typical)		67% min. (Varies depending on specifications)				83% min.	75% min.	82% min.		
Input	Voltage (See note 2.)	100 to 240 VAC (85 to 264 VAC) 110 to 170 VDC (10-W and 25-W models only) (See note 11.)				100 VAC (85 to 132 VAC) 200 VAC (170 to 264 VAC) (selected automatically)		100 VAC (85 to 132 VAC) 200 VAC (170 to 253 VAC) (selectable)		
	Frequency (See note 2.)	50/60 Hz (47 to 450 Hz)								
	Current (See note 3.)	100-V input	0.35 A max.	0.8 max.	1.4 A max.	2.5 A max.	2.5 A max.	3.5 A max.	8 A max.	14 A max.
		200-V input	0.3 A max.	0.6 A max.	0.8 A max.	1.5 A max.	1.4 A max.	2.1 A max.	4 A max.	7 A max.
	Leakage current (See note 3.)	100-V input	0.5 mA max.							
		200-V input	1 mA max.							
	Inrush current (See note 3.)	100-V input	25 A max. (for cold start at 25°)							30 A max. (for cold start at 25°)
200-V input		50 A max. (for cold start at 25°)							60 A max. (for cold start at 25°)	
Noise filter		Yes								
Output (See note 4.)	Voltage Adjustment Range (See note 5.)	±10% (with V. ADJ)								
	Ripple (See note 3.)	2% (p-p) max.								
	Input variation influence	0.4% max.								
	Load variation influence	0.8% max. (10% to 100% load, rated input voltage)								
	Temperature variation influence	0.05%/° max. (at rated input and output)								
	Start up time	500 ms max. (up to 90% of output voltage at rated input and output)							300 ms max. (up to 90% of output voltage at rated input and output)	
	Hold time (See note 3.)	20 ms min.								
Additional functions	Overload protection (See note 6.)	105% to 160% of rated load current, voltage/current drop, intermittent operation (10-W and 25-W models) gradual current increase/ voltage drop, intermittent operation (50-W, 100-W (24 V) models), automatic reset					105% of rated load current, Inverted L voltage drop, automatic reset (For the 600-W model, the circuit will be shut OFF when the overload exceeds 5 s.)			
	Overvoltage protection	No			Yes (See note 7.)	Yes (5-V output only) (See note 7.)	No	Yes (See note 8.)		
	Overheat protection	No								Yes (See note 8.)
	Parallel operation	No								Yes (up to 5 units)
	Protection-ON alarm indicator	No								Yes (color: red)
Other	Operating ambient temperature	Refer to the derating curve in <i>Engineering Data</i> . (with no icing or condensation)								
	Storage temperature	-25 to 65°C (with no icing or condensation)								
	Operating ambient humidity	25% to 85% (Storage humidity: 25% to 90%)								
	Dielectric strength	3.0 k VAC for 1 min. (between all inputs and all outputs)								
		2.2 k VAC for 1 min. (between all inputs and all outputs/PE terminals)								
		1.0 k VAC for 1 min. (between all outputs and all PE terminals)								
	Insulation resistance	100 MΩ min. (between all outputs and all inputs/ PE terminals) at 500 VDC								
	Vibration resistance	10 to 55 Hz, 0.375-mm single amplitude for 2h each in X, Y, and Z directions								
	Shock resistance	300m/s ² , 3 times each in ±X, ±Y, ±Z directions								
	Output indicator	Yes (color: green)								
	EMI	Conducted Emissions (See note 3.)	Conforms to EN61204-3 EN55011 Class A and based on FCC Class A							
		Radiated Emissions	Conforms to EN61204-3 EN55011 Class A (See note. 9)							
	EMS		Conforms to EN61204-3 Low severity levels							
	Approved standards		UL: UL508 (Listing, Class 2), No. 60950-1 (Class 2 approved for 10-W, 25-W (except for 5-V output), and 50-W (only for 24-V output) models.) CSA: cUL: C22.2 No.14 (Class 2), cUR: No. 60950-1 (Class 2 approved for 10-W, 25-W (except for 5-V output), and 50-W (only for 24-V output) models.) EN/VDE: EN50178 (VDE0160), EN60950-1 (VDE0805 Teil 1) Terminal types (only terminal part): VDE0106/P100 Based on VE0106/P100				UL: UL 508 (Listing), 1012, 60950-1 CSA: cUL: C22.2 No. 14, cUR: No. 60950-1 EN/VDE: EN50178 (VDE0160), EN60950-1 (VDE0805 Teil 1) Terminal types (only terminal part): VDE0106/P100 Based on VE0106/P100		UL: UL 508 (Listing), 1012, 60950-1 CSA: cUL: C22.2 No. 14, cUR: No. 60950-1 EN/VDE: EN50178 (VDE0160), EN60950-1 (VDE0805 Teil 1) Terminal types (only terminal part): VDE0106/P100 Based on VE0106/P100	
Weight		250 g max.	350 g max.	400 g max.	500 g max.	1,000 g max.		2,000 g max.	2,500 g max.	

- Note:**
1. When a load is connected that has a built-in DC-DC converter, the overload protection may operate at startup and the power supply may not start.
Refer to the *Overload Protection* section on page 10 for details.
 2. Do not use the Inverter output for the Power Supply. Inverters with an output frequency of 50/60 Hz are available, but the rise in the internal temperature of the Power Supply may result in ignition or burning.
 3. Defined with a 100% load and the rated input voltage (100 or 200 VAC.)
 4. The output specification is defined at the Power Supply output terminals.
 5. If the V. ADJ adjuster is turned the voltage will increase by more than +10% of the voltage adjustment range.
When adjusting the output voltage, confirm the actual output voltage from the Power Supply and be sure that the load is not damaged.
 6. Refer to the *Overload Protection* section on page 10 for details.
 7. For resetting, turn OFF the power, leave for more than one minute, and then turn it ON again.
 8. The protection-ON alarm indicator will light as soon as the output is interrupted. For resetting, turn OFF the input power, leave for more than three minutes (90 seconds min. for the 300-W models), and then turn it back ON again.
 9. Radiated emissions: The noise value is affected by factors such as the wiring method. For 300-W and 600-W models, use shielded wire for all wiring, and insert one noise clamp filter (TDK, ZCAT3035-1330) on the input wire, and two noise clamp filters on the load wire.
 10. The weight indicated is the weight of the open-frame type. (Includes the covers for 300-W and 600-W models)
 11. Use with DC voltage input is beyond the conditions of approval or conformance to applicable safety standards.

Connections

Block Diagrams

S82J-010□□□□ (10 W)

S82J-025□□□□ (25 W)

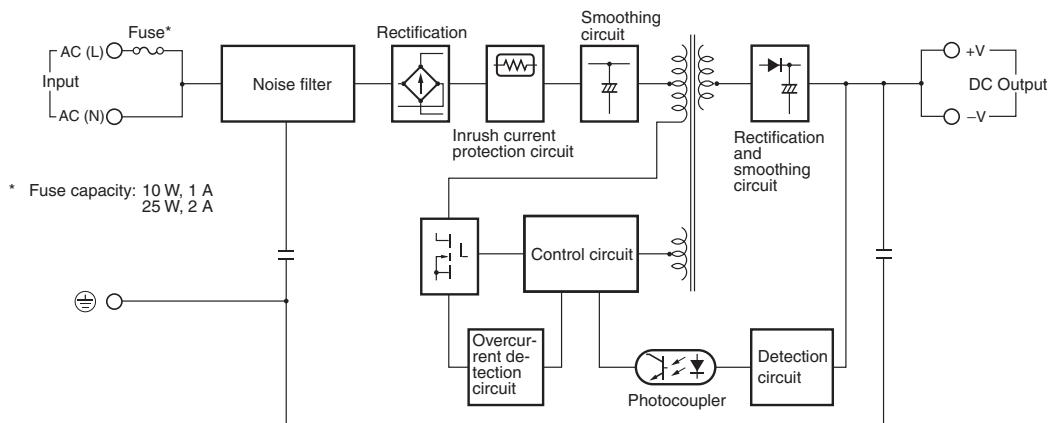

S82J-050□□□□ (50 W)

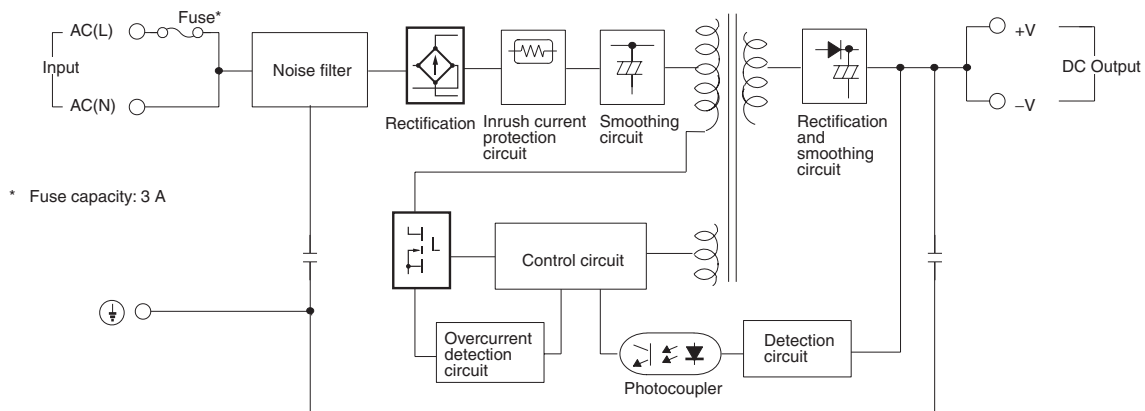

S82J-100 (100 W, 5-/12-/15-V Output)

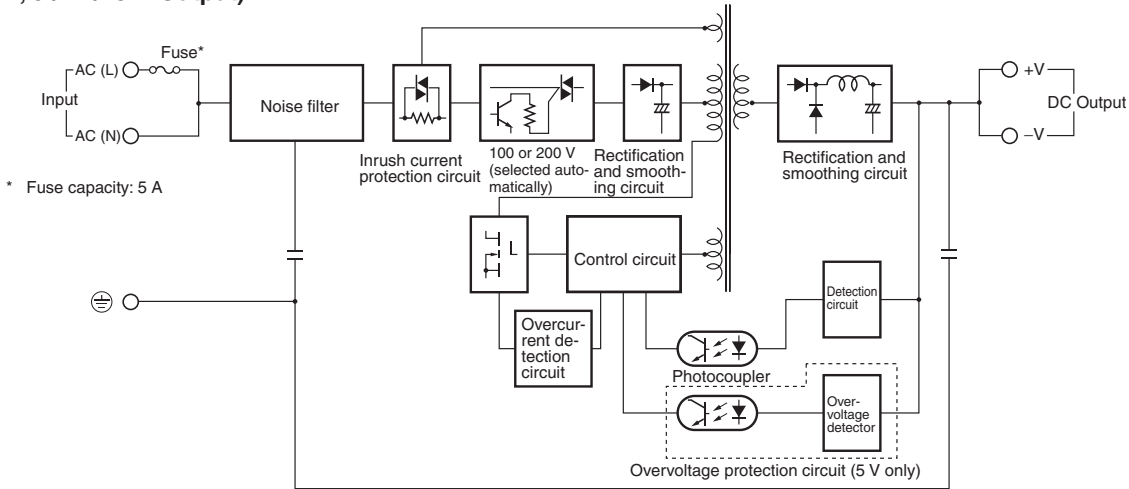

S82J-10024 (100 W, 24-V Output)

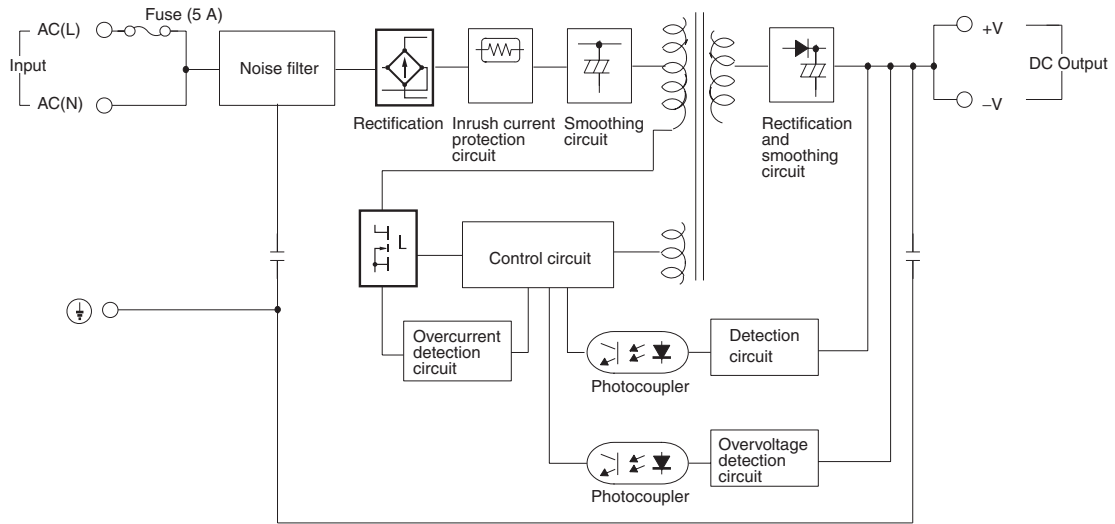

S82J-15024 (150 W)

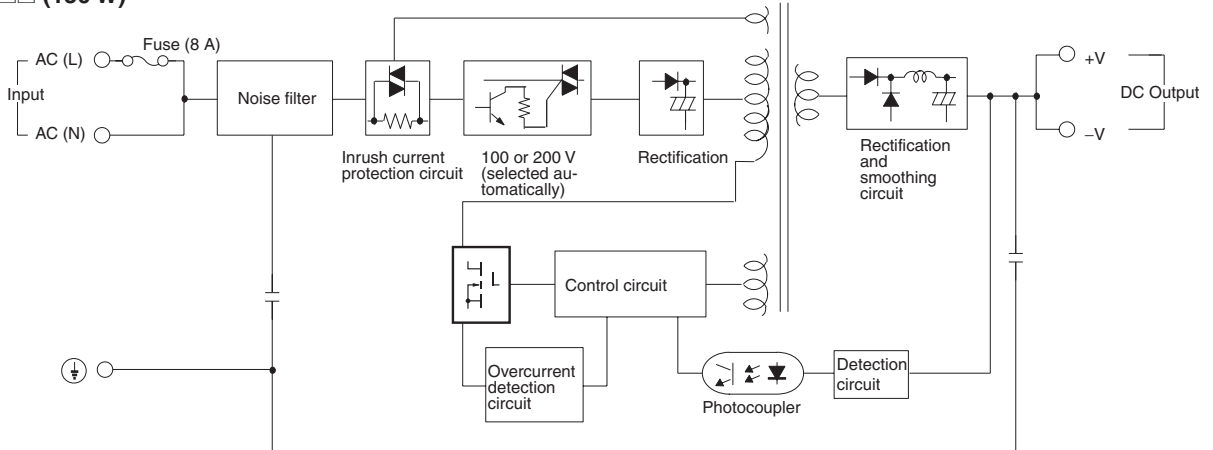

S82J-30024□ (300 W)

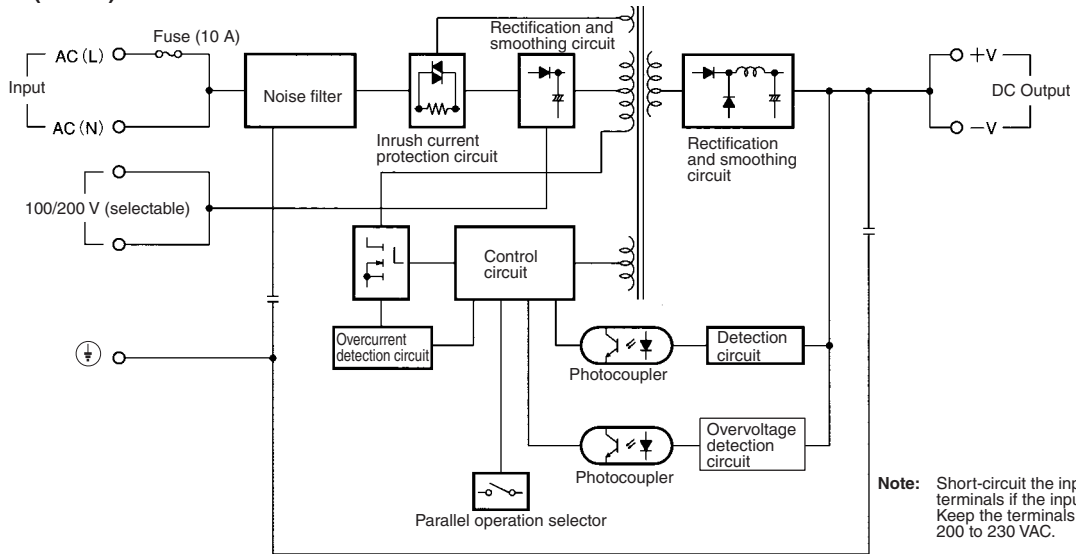

S82J-60024□ (600 W)

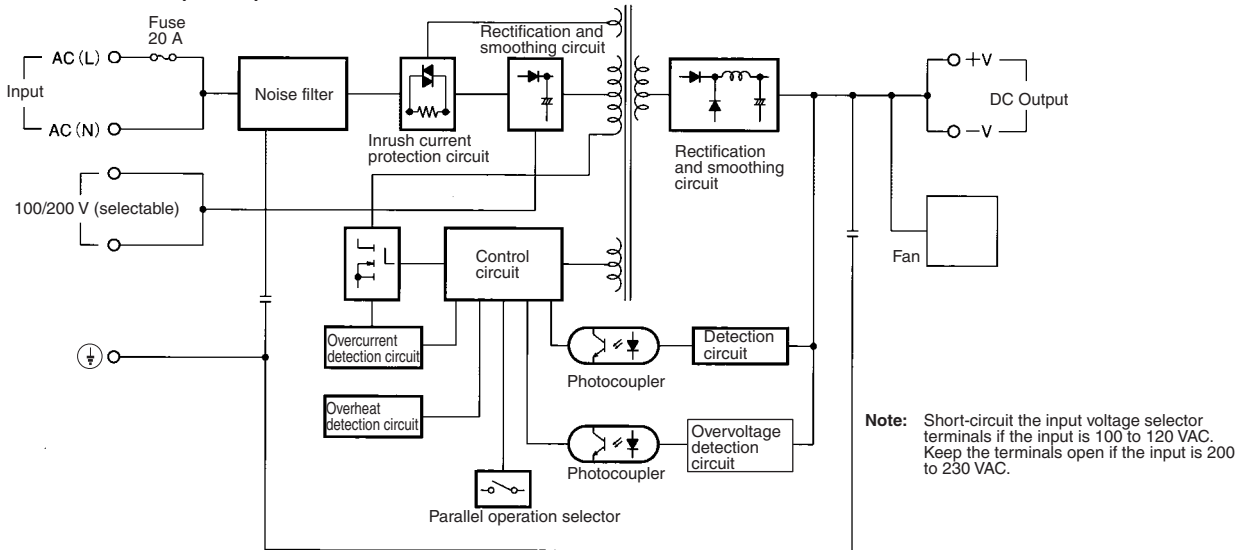

Construction and Nomenclature

■ Nomenclature

10-/25-/50-/100-/150-W Models

Front Terminals Model

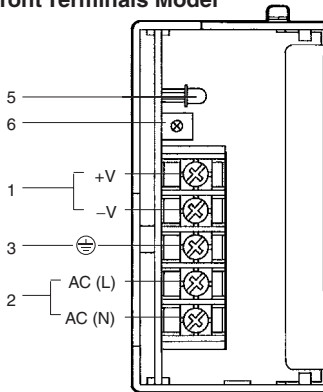

300-W Models

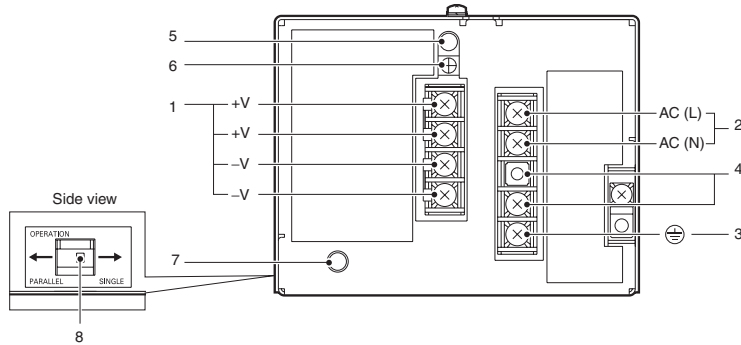

600-W Models

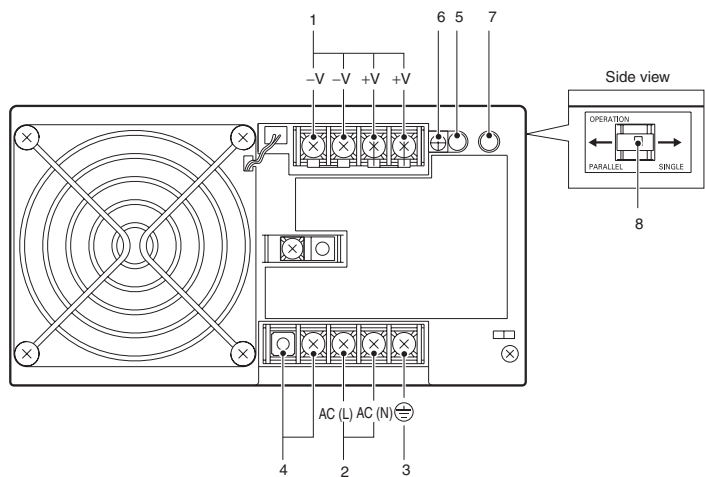

1. **DC Output Terminals:** Connect the load lines to these terminals.
 2. **AC Input Terminals:** Connect the input lines to these terminals.
- Note:** 1. The fuse is located on the (L) side. It is NOT user replaceable.
2. For DC input (10-W, 25-W models), use the (L) terminal as the positive terminal.
3. **PE Terminal/Protective earthing terminal:** Connect the ground line to this terminal.
 4. **Input Voltage Selector Terminals:** Short-circuit the terminals if the input is 100 to 120 VAC and open the terminals if the input is 200 to 230 VAC
 5. **Output Indicator (DC ON: Green):** Lights while a Direct Current (DC) output is ON.
 6. **Output Voltage Adjuster (V.ADJ):** It is possible to increase or decrease the output voltage by 10%.
 7. **Protection-ON Alarm Indicator (DC ON: Red):** The red indicator will be lit if the overvoltage (for a 300-/600-W model) or overheat protection (for a 600-W model) circuit is triggered. This indicator will also be lit when overcurrent (for a 600-W model) is detected.
 8. **Parallel/Single Operation Selector:** Set the selector to PARALLEL if the Units are in parallel operation.

Engineering Data

Derating Curve (for standard mounting)

10-/25-/50-/100-/150-W Model

Open-frame type

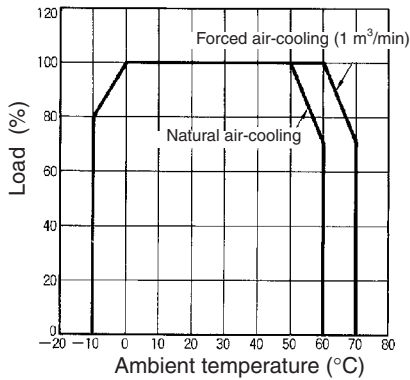

Covered-type

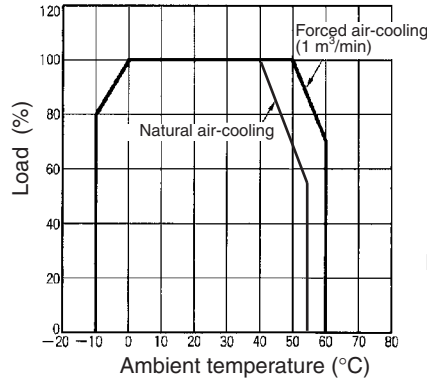

Standard Mounting

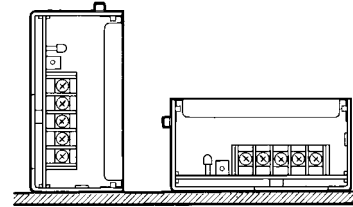

Note: The derating curve shown is for standard mounting. The derating curve depends on the mounting direction of the Power Supply.

300-W Model

Single Operation

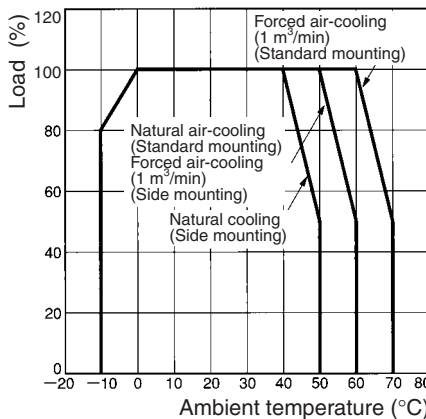

Parallel Operation

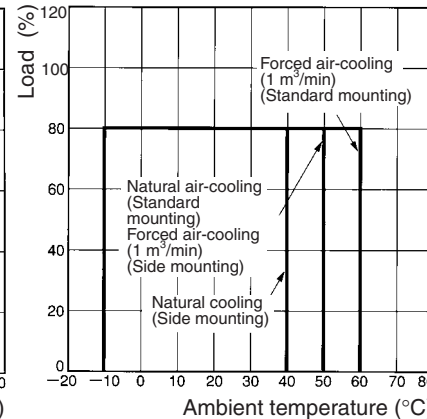

Standard Mounting

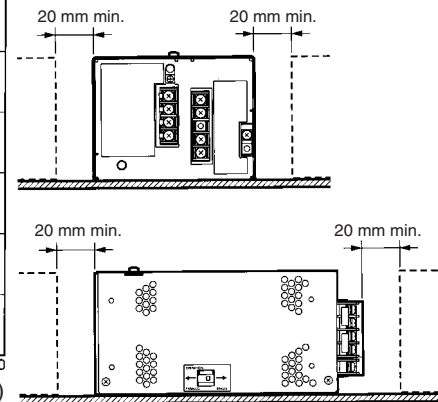

Note: Provide a minimum clearance of 20 mm between the Power Supplies.

600-W Model

Single Operation

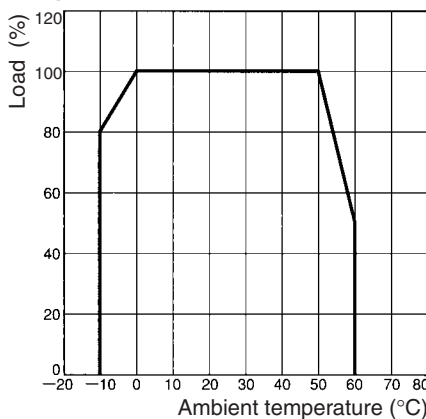

Parallel Operation

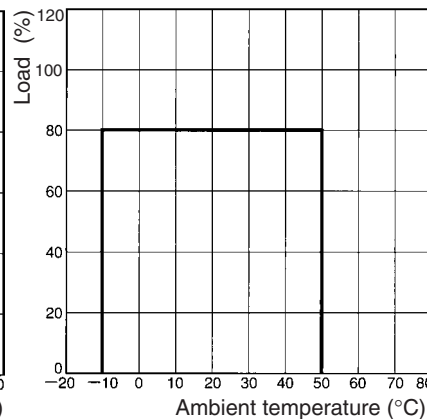

Standard Mounting

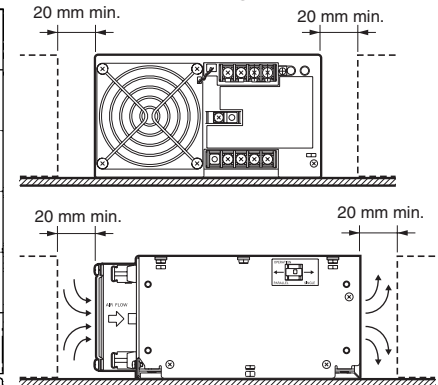

Note: Provide a minimum clearance of 20 mm between the Power Supplies.

■ Overload Protection

10- to 300-W Models

The Power Supply is provided with an overload protection function that protects the power supply from possible damage by overcurrent. When the output current rises above 105% to 160% of the rated output current, the protection function is triggered, automatically decreasing the output voltage. When the output current falls within the rated range, the overload protection function is automatically cleared.

10 W, 25 W Models

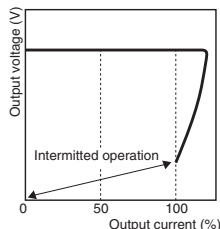

50 W, 100 W (24 V) Models

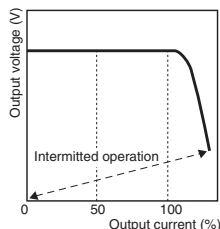

100 W (5 V, 12 V, 15 V), 150 W, 300 W Models

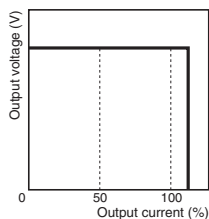

- Note:**
1. If the S82J is connected to a load with a built-in DC-DC converter, the overload protection function may be triggered at startup, and consequently the S82J may not operate.
 2. Internal parts may occasionally deteriorate or be damaged if a short-circuited or other overcurrent state continues during operation. Eliminate the overcurrent state as soon as possible.
 3. In actual operation, the output voltage may not fall to 0 V when the overload protection function is triggered. Even with short-circuits on the load side, the drop in voltage will vary depending on factors such as the impedance in the load line.
 4. The overload protection function is activated at 105% of the rated output current for 300-W models.

600-W Models

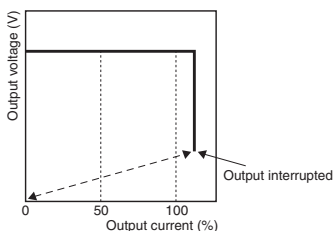

If an excessive current flows for 5 s or more, the output will be turned OFF and simultaneously the protection-ON alarm indicator will be lit. To reset the S82J, turn OFF the power, leave the S82J for at least three minutes, and then turn ON the power again.

Note: Internal parts may occasionally deteriorate or be damaged if a short-circuited or other overcurrent state continues during operation. Eliminate the overcurrent state as soon as possible.

■ Overvoltage Protection

100-W (5-, 24-V Output) Models

Consider the possibility of an overvoltage and design the system so that the load will not be subjected to an excessive voltage even if the feedback circuit in the Power Supply fails. When an excessive voltage that is approximately 120% of the rated voltage or more is output, the output voltage is shut OFF, preventing damage to the load due to overvoltage. Reset the power by turning it OFF for at least one minute and then turning it back ON again.

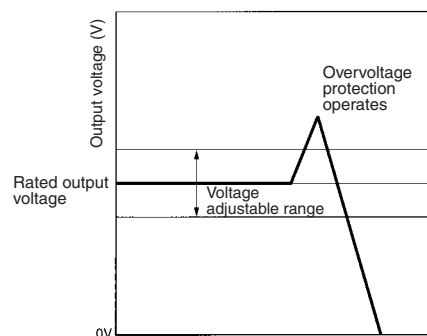

300- and 600-W Models

When an excessive voltage that is approximately 120% of the rated voltage or more is output, the output voltage will be turned OFF and simultaneously the protection-ON alarm indicator will be lit. To reset the S82J, turn OFF the power, leave the S82J for at least three minutes if it is a 600-W model or at least 90 seconds if it is a 300-W model, and then turn it back ON again.

■ Overheat Protection Function

600-W Models Only

If the internal temperature of the S82J rises excessively as a result of fan failure or any other reason, the overheat protection circuit will be triggered to protect the internal elements of the S82J and simultaneously the protection-ON alarm indicator will be lit. To reset the S82J, turn OFF the power, leave the S82J for at least three minutes, and then turn it back ON again.

■ Inrush Current, Startup Time, Hold Time

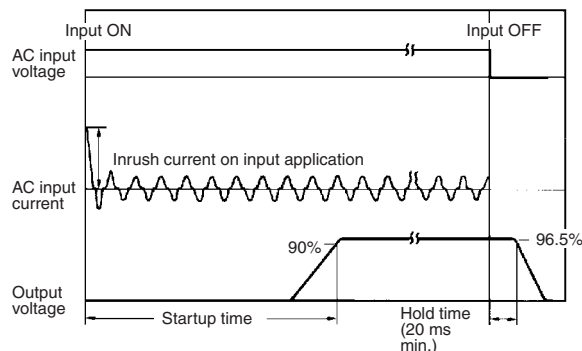

Dimensions

Note: All units are in millimeters unless otherwise indicated.
Open-frame type and covered type have the same dimensions.

Front-mounting Bracket Type

S82J-010□□□ (10 W)

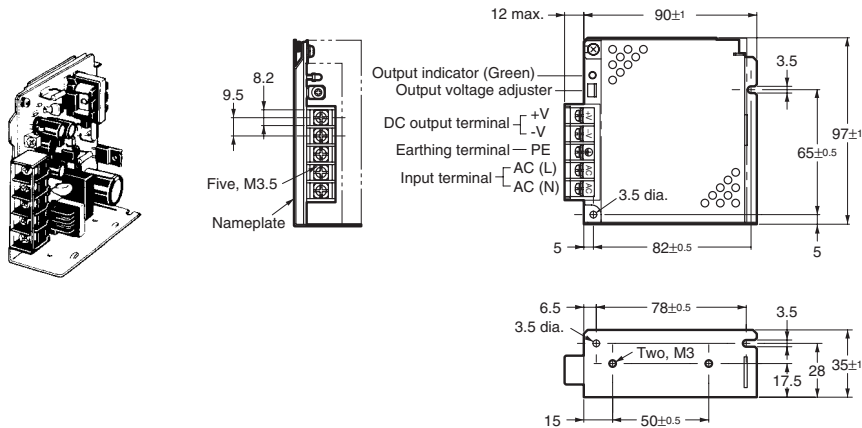

Mounting Holes
(Surface Screw Mounting)

Side Mounting

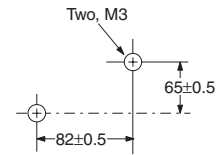

Bottom Mounting

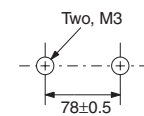

S82J-025□□□ (25 W)

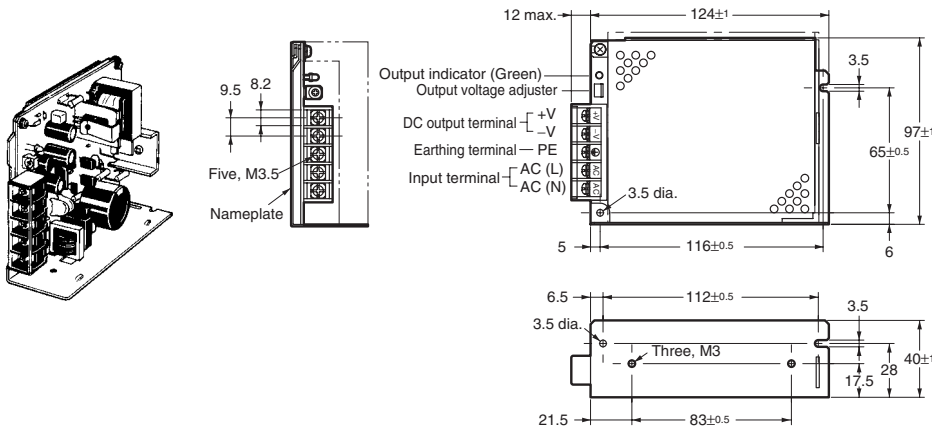

Mounting Holes
(Surface Screw Mounting)

Side Mounting

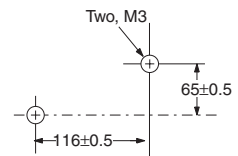

Bottom Mounting

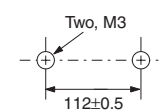

S82J-050□□□ (50 W)

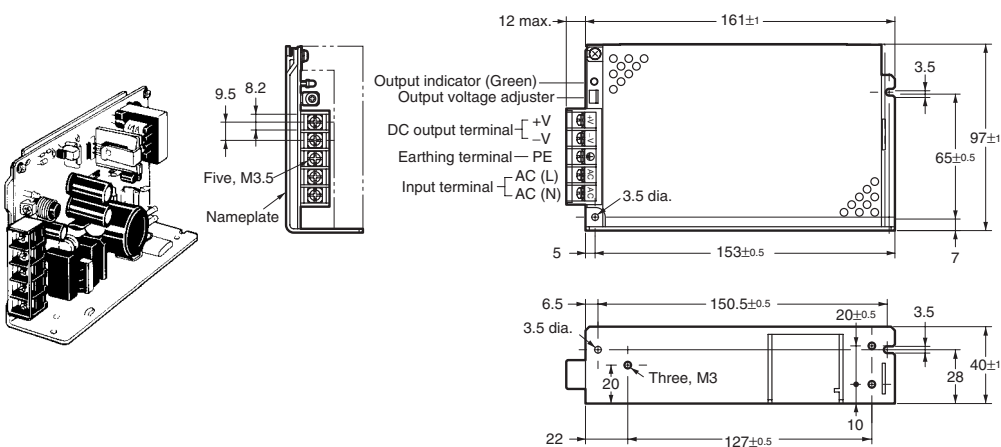

Mounting Holes
(Surface Screw Mounting)

Side Mounting

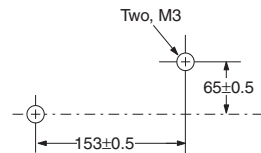

Bottom Mounting

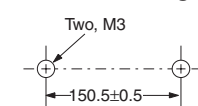

S82J-10024 (100 W, 24-V Output)

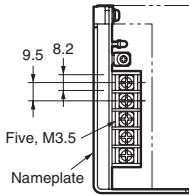
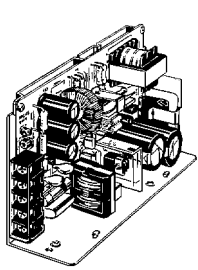

Output indicator (Green)
Output voltage adjuster
DC output terminal — +V
— -V
Earthing terminal — PE
Input terminal — AC (L)
— AC (N)

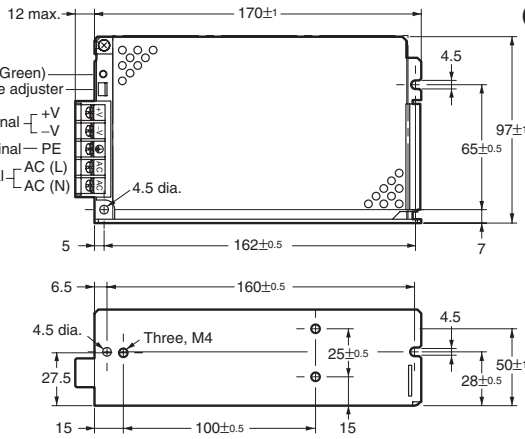

Mounting Holes (Surface Screw Mounting)

Side Mounting

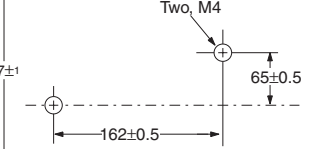

Bottom Mounting

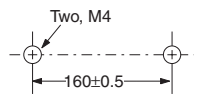

S82J-100 (100 W, 5-/12-/15-V Output)
S82J-15024 (150 W)

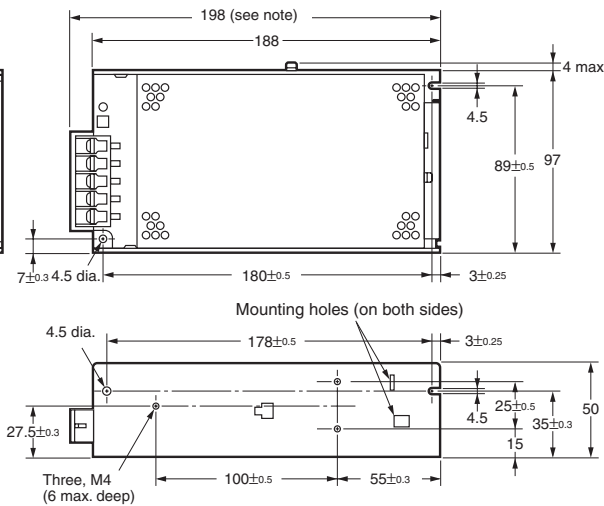
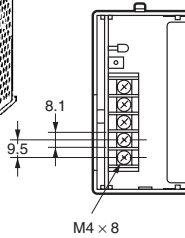
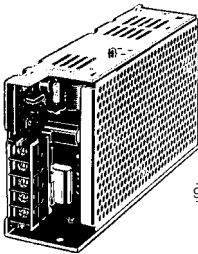

Mounting Holes (Surface Screw Mounting)

Side Mounting

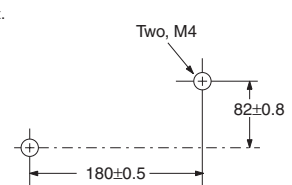

Bottom Mounting

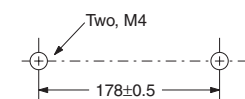

S82J-30024 (300 W)

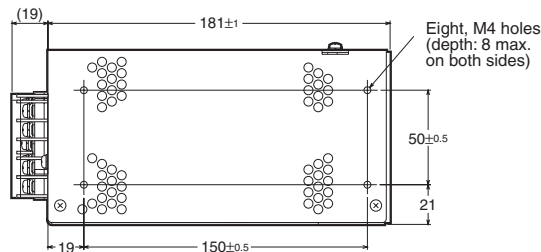
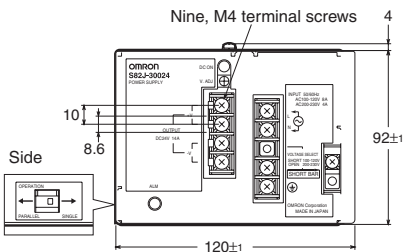

Mounting Holes (Surface Screw Mounting)

Side Mounting

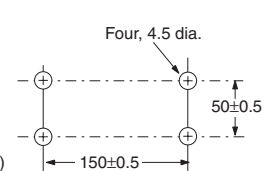

Bottom Mounting

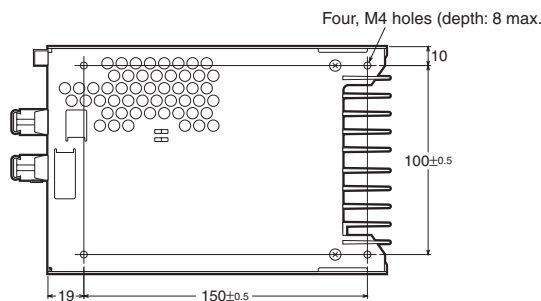
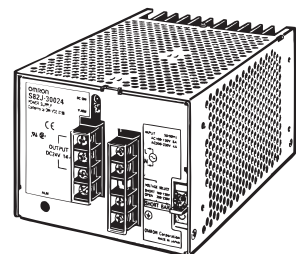
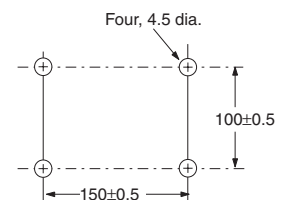

S82J-60024□ (600 W)

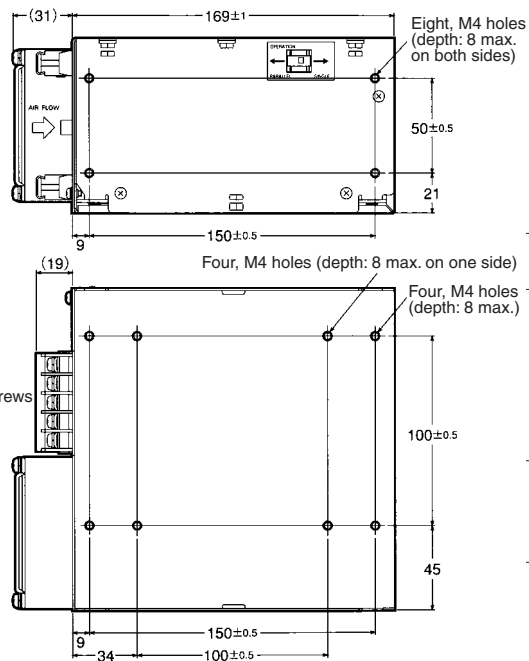
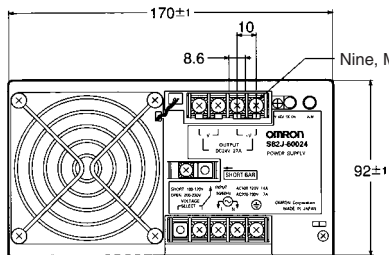
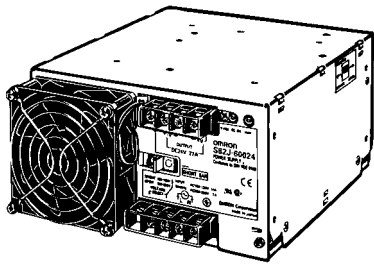

Mounting Holes (Surface Screw Mounting)

Side Mounting

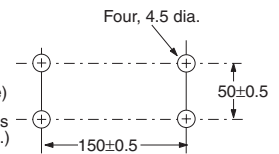

Bottom Mounting

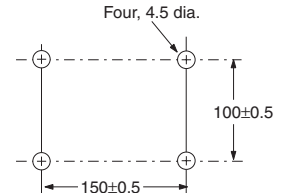

Dimensions with Mounting Brackets (Provided)

For 10-/25-/50-/100 (24 V)-W Models

Front-mounting Bracket (Provided)

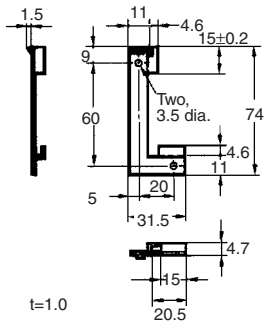

Material: Stainless steel

Mounting Holes

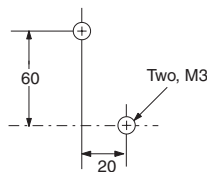

Using the Mounting Bracket

Attach the mounting bracket to the panel and loosely tighten the two screws. Insert the projected parts of the bracket (b) to the square holes of the power supply (a). Then securely tighten the screws.

Note: The mounting screws must be ordered separately.

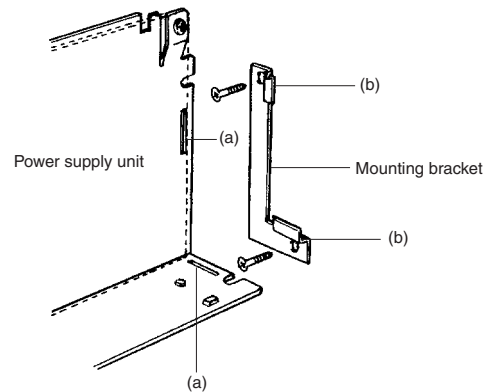

For 100- (5, 12, 15 V) and 150-W Models

Front-mounting Bracket (Provided)

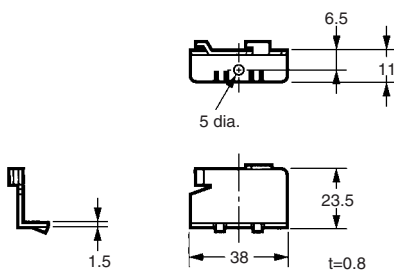

Note: The brackets are for front-mounting.

Dimensions with Mounting Brackets

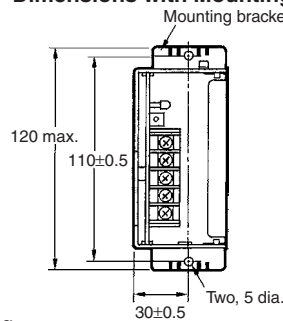

Attaching the Mounting Brackets

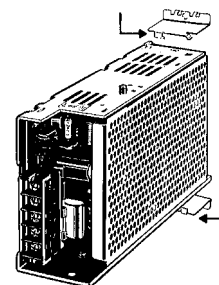

300-W and 600-W Models

Note: A mounting bracket is included with the S82J-30024 and S82J-60024, but not with the S82J-30024N and S82J-60024N.

**Front-mounting Bracket
For 300-W Models (S82Y-J30F)**

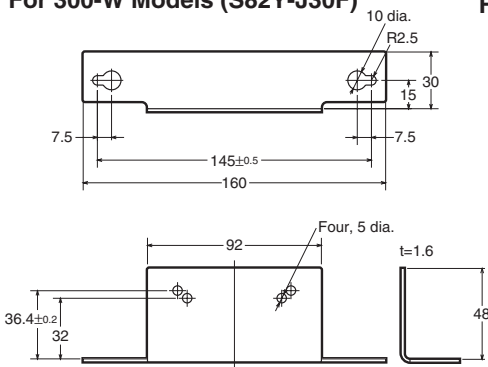

Note: Mounting Brackets are provided in a set, one for the right side and one for the left side.

**Dimensions with Mounting Brackets Attaching the Mounting Brackets
For 300-W Models**

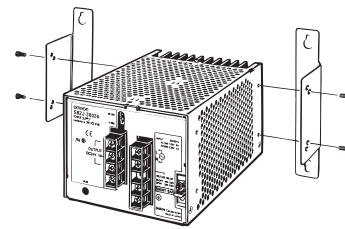
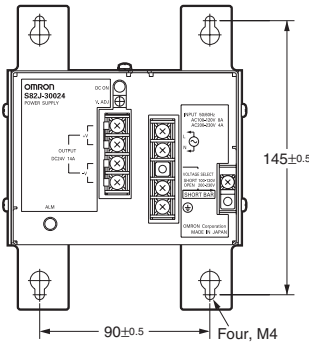

Note: To provide ventilation space, the body will shift forward by 21.6 mm from the mounting surface.

**Dimensions with Mounting Brackets Attaching the Mounting Brackets
For 600-W Models**

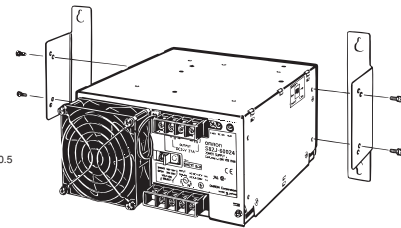
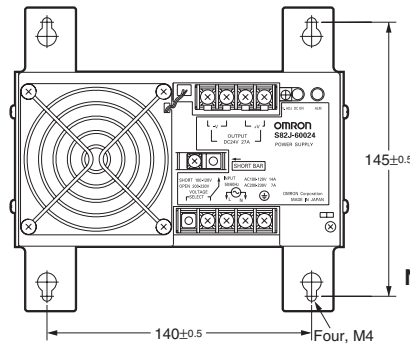

Note: To provide ventilation space, the body will shift forward by 23.6 mm from the mounting surface.

■ DIN Rail Mounting Bracket Type

S82J-010□□□D (10 W)

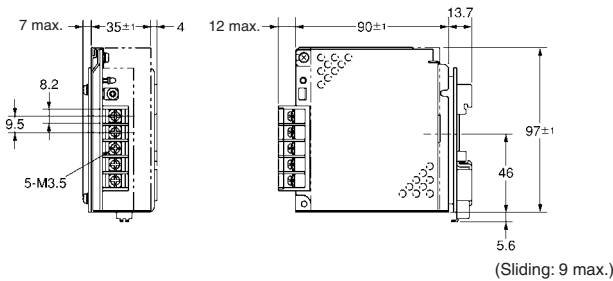
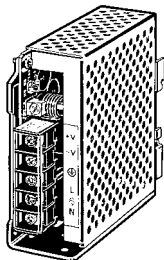

S82J-025□□□D (25 W)

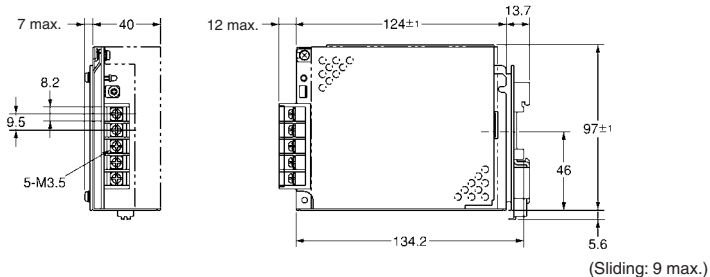
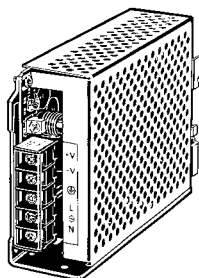

S82J-050□□□D (50 W)

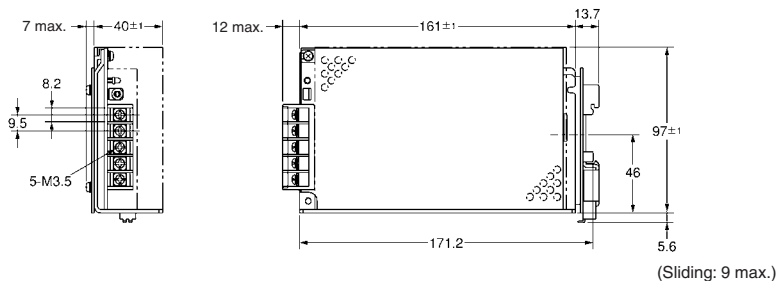
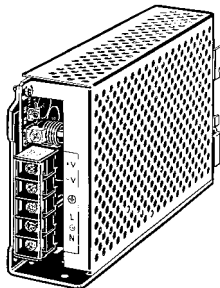

S82J-10024□D
(100 W, 24-V Output)

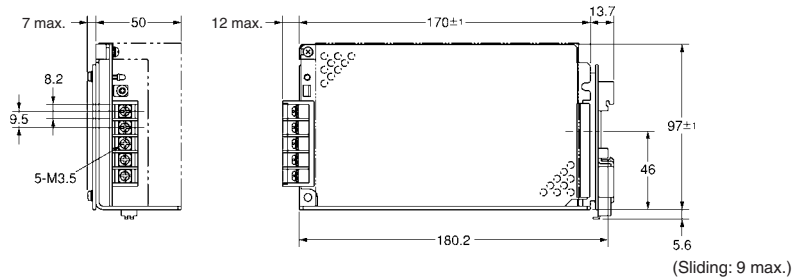
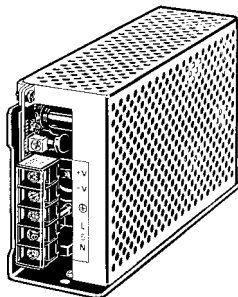

S82J-100□□□D (100 W, 5-/12-/15-V Output)
S82J-15024□□D (150 W)

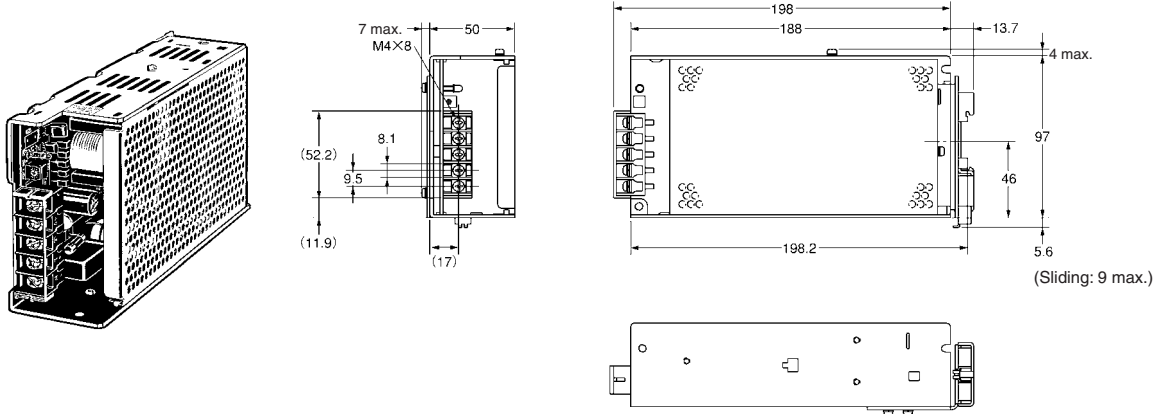

■ Front-mounting Bracket for S82J-10024A/-10024D Power Supply (Order Separately)

(Unit: mm)

Product	Model number	Dimensions	Mounting hole dimensions
Front-mounting Bracket	S82Y-J10F		

Note: These Front-mounting brackets cannot be used with S82J 100-W (5, 12, or 15-V) or 150-W models.

■ DIN Rail Mounting Bracket (Order Separately)

Can be used with 10-W to 150-W Front-mounting bracket models.

If DIN Rail mounting is necessary, use a DIN Rail Mounting Bracket.

Model	Power Rating	Applicable Quick-mounting Base
S82J	10 W	S82Y-01N
	25 W	S82Y-03N
	50 W	S82Y-05N
	100 W, 150 W	S82Y-10N

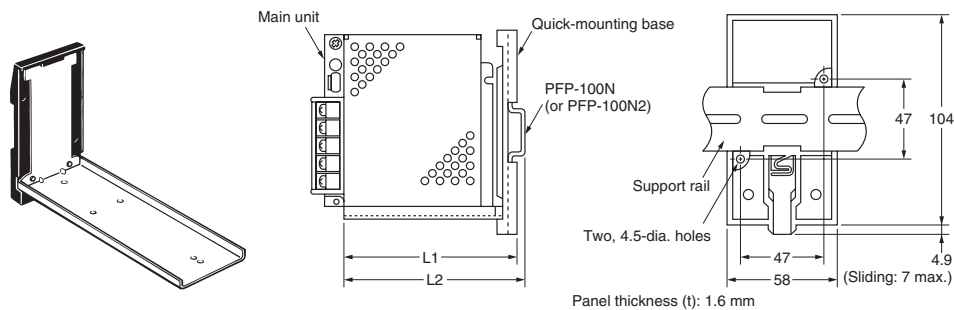

Size

Model	L1	L2 (See note.)
S82Y-01N	113	114.8
S82Y-03N	143	144.8
S82Y-05N	163	164.8
S82Y-10N	185	186.8

Note: The L2 dimension refers to using the PFP-100N on a DIN rail. When using the PFP-100NS, add 10.5 mm to L2.

Safety Precautions

CAUTION

Minor electric shock, fire, or Product failure may occasionally occur. Do not disassemble, modify, or repair the Product or touch the interior of the Product.



Minor burns may occasionally occur. Do not touch the Product while power is being supplied or immediately after power is turned OFF.



Fire may occasionally occur. Tighten terminal screws to the specified torque 0.74 N·m for 10-, 25-, 50-, or 100-W models (24-V output); or 1.08 N·m for 100- (5-, 12-, or 15-V output), 150-, 300-, or 600-W models.



Minor injury due to electric shock may occasionally occur. Do not touch the terminals while power is being supplied.



Minor electric shock, fire, or Product failure may occasionally occur. Do not allow any pieces of metal or conductors or any clippings or cuttings resulting from installation work to enter the Product.



Precautions for Safe Use

Mounting

To improve and maintain the reliability of the Power Supply over a long period of time, adequate consideration must be given to heat radiation.

The Power Supply is designed to radiate heat by means of natural air-flow. Therefore, mount the Power Supply so that air flow takes place around the Power Supply.

When mounting the Power Supply, mounting it to a metal plate is recommended.

When mounting two or more Power Supplies side-by-side, allow at least 20 mm spacing between them, as shown in the following illustration.

Forced air-cooling is recommended.

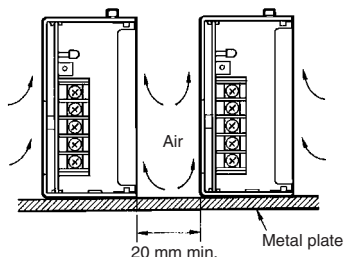

Switching the AC Input Voltage between 100 and 200 V (300- and 600-W Models)

The input voltage can be switched between 100 and 200 V by shorting or opening the input voltage selection terminals. Set the required voltage as shown below. (The voltage is factory-set to 200 V.)

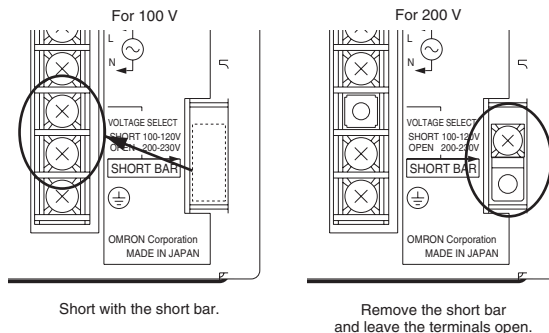

Note: A 300-W Model is shown above.

Mounting Methods

The following mounting methods are available.

10-/25-/50-/100 (24 V)-W Models

- (A) Side mounting
- (B) Bottom mounting
- (C) Front mounting (see *Accessories*)

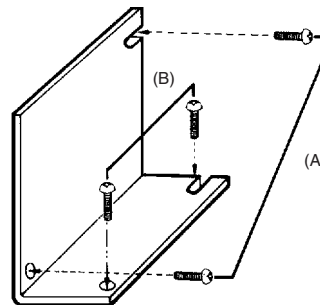

100 (5, 12, 15 V)/150-/300-/600-W Models

- (A) Side mounting
- (B) Bottom mounting (secured with screws from the inside of the Switching Power Supply) (except for 300- and 600-W models)
- (C) Bottom mounting (secured with screws from the back of the Switching Power Supply)

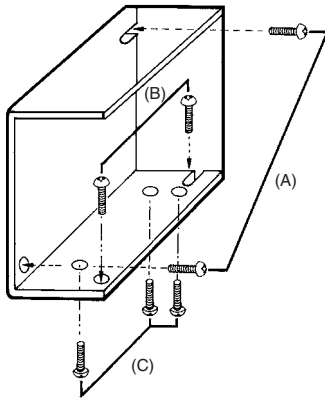

(D) Front mounting
 Front mounting is possible with the mounting brackets provided. Refer to *Dimensions* on page 11.

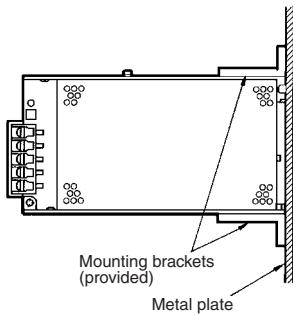

Series Operation

Only models with power ratings of 50, 100, 150, 300, or 600-W allow series operation.

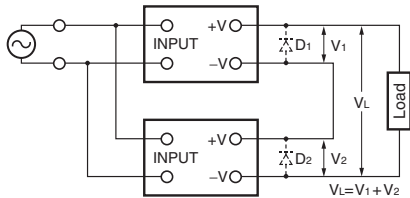

Model	Output capacity	Rated output voltage
S82J	100 W	5, 12, 15, 24 VDC
	50, 150, 300, 600 W	24 VDC

Up to two of the above Power Supplies can be used in series operation.

Models other than the above Power Supplies cannot be used in series operation.

If series operation is attempted for other models, the output from one of the Power Supplies may not come ON when the AC input is applied. If that occurs and the Power Supplies are left in that state, internal circuits may be damaged.

Although Power Supplies having different specifications can be connected in series, the current flowing through the load must not exceed the smaller rated output current.

With the S82J-05024□□ or S82J-10024□□, if the load is shorted a reverse voltage may result in the Power Supply causing deterioration and damage. It is recommended that diodes are connected as shown in the previous diagram (D_1 , D_2).

Type	Schottky barrier diode
Dielectric strength (V_{RRM})	Twice the rated output voltage or above
Forward current (I_F)	Twice the rated output current or above

Parallel Operation

Only 300- and 600-W models can be in parallel operation. Do not operate any other models in parallel. The output of the models in parallel operation is a maximum of 80% of the rated output.

Set the parallel operation selector to PARALLEL if the Units are in parallel operation and make sure that the thickness and the length of all wires connected to the load are the same to ensure that the wires will have no voltage drop differences.

Fan Replacement

The service life of the fan is approximately 50,000 hours (at 25°C). The service life varies, however, depending on the ambient temperature or other surrounding environmental conditions such as dust. As a preventive maintenance measure, replace the fan within two years if it is used at an ambient temperature of 40°C.

Fans are available as replacements.

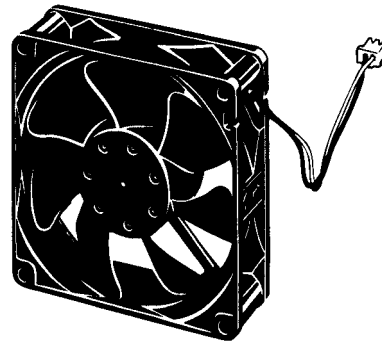

Model: S82Y-JFAN

Fan Set:
 Fan (above), four M4 x 35 sems screws, instruction sheet, and packing case

Replace the fan as shown in the following illustration.

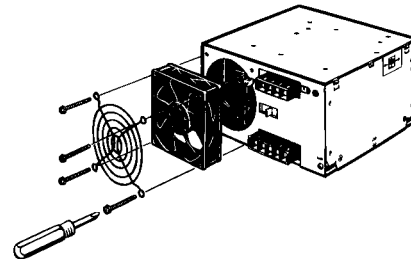

Warranty and Application Considerations

Read and Understand this Catalog

Please read and understand this catalog before purchasing the products. Please consult your OMRON representative if you have any questions or comments.

Warranty and Limitations of Liability

WARRANTY

OMRON's exclusive warranty is that the products are free from defects in materials and workmanship for a period of one year (or other period if specified) from date of sale by OMRON.

OMRON MAKES NO WARRANTY OR REPRESENTATION, EXPRESS OR IMPLIED, REGARDING NON-INFRINGEMENT, MERCHANTABILITY, OR FITNESS FOR PARTICULAR PURPOSE OF THE PRODUCTS. ANY BUYER OR USER ACKNOWLEDGES THAT THE BUYER OR USER ALONE HAS DETERMINED THAT THE PRODUCTS WILL SUITABLY MEET THE REQUIREMENTS OF THEIR INTENDED USE. OMRON DISCLAIMS ALL OTHER WARRANTIES, EXPRESS OR IMPLIED.

LIMITATIONS OF LIABILITY

OMRON SHALL NOT BE RESPONSIBLE FOR SPECIAL, INDIRECT, OR CONSEQUENTIAL DAMAGES, LOSS OF PROFITS, OR COMMERCIAL LOSS IN ANY WAY CONNECTED WITH THE PRODUCTS, WHETHER SUCH CLAIM IS BASED ON CONTRACT, WARRANTY, NEGLIGENCE, OR STRICT LIABILITY.

In no event shall the responsibility of OMRON for any act exceed the individual price of the product on which liability is asserted.

IN NO EVENT SHALL OMRON BE RESPONSIBLE FOR WARRANTY, REPAIR, OR OTHER CLAIMS REGARDING THE PRODUCTS UNLESS OMRON'S ANALYSIS CONFIRMS THAT THE PRODUCTS WERE PROPERLY HANDLED, STORED, INSTALLED, AND MAINTAINED AND NOT SUBJECT TO CONTAMINATION, ABUSE, MISUSE, OR INAPPROPRIATE MODIFICATION OR REPAIR.

Application Considerations

SUITABILITY FOR USE

OMRON shall not be responsible for conformity with any standards, codes, or regulations that apply to the combination of products in the customer's application or use of the products.

Take all necessary steps to determine the suitability of the product for the systems, machines, and equipment with which it will be used.

Know and observe all prohibitions of use applicable to this product.

NEVER USE THE PRODUCTS FOR AN APPLICATION INVOLVING SERIOUS RISK TO LIFE OR PROPERTY WITHOUT ENSURING THAT THE SYSTEM AS A WHOLE HAS BEEN DESIGNED TO ADDRESS THE RISKS, AND THAT THE OMRON PRODUCTS ARE PROPERLY RATED AND INSTALLED FOR THE INTENDED USE WITHIN THE OVERALL EQUIPMENT OR SYSTEM.

Disclaimers

PERFORMANCE DATA

Performance data given in this catalog is provided as a guide for the user in determining suitability and does not constitute a warranty. It may represent the result of OMRON's test conditions, and the users must correlate it to actual application requirements. Actual performance is subject to the OMRON *Warranty and Limitations of Liability*.

CHANGE IN SPECIFICATIONS

Product specifications and accessories may be changed at any time based on improvements and other reasons. Consult with your OMRON representative at any time to confirm actual specifications of purchased product.

DIMENSIONS AND WEIGHTS

Dimensions and weights are nominal and are not to be used for manufacturing purposes, even when tolerances are shown.

ALL DIMENSIONS SHOWN ARE IN MILLIMETERS.

To convert millimeters into inches, multiply by 0.03937. To convert grams into ounces, multiply by 0.03527.

Cat. No. T036-E1-01 **In the interest of product improvement, specifications are subject to change without notice.**

OMRON Corporation

Industrial Automation Company

Control Devices Division H.Q.

Power Electronics Department

Shiokoji Horikawa, Shimogyo-ku,

Kyoto, 600-8530 Japan

Tel: (81)75-344-7108/Fax: (81)75-344-7189

Printed in Japan

1105-1.5M (1105) (C)