

The Most Compact DIN-track-mounting Switching Power Supplies Ever with Capacities Up to 600 W

- Power range from 50 W up to 600 W.
- Open-frame and covered types available.
- Easily mounted to DIN track with provided Mounting Brackets.
- Models with Front-mounting Bracket available.
- Conforms to EMC standards: EN50081-1, EN50082-2, and EN61000-3-2.
- Maintenance-free up to 300 W due to natural ventilation.
- Protection-ON alarm indicator shows valuable protection functions in action (300-/600-W models).
- AC universal input: 100 to 240 VAC
- Approved by UL/CSA standards, EN60950 (IEC950), and VDE0160.
- Six-language instruction manual provided.
- Life expectancy of 10 years min.
- Finger protection terminal block meets VDE0106/P100. (Covered type)



Ordering Information

■ S8PS

Configuration	Input voltage	Power ratings	Output voltage	Output current	Front-mounting Bracket	DIN Track Mounting Bracket	
Covered type	100 to 240 VAC	50 W	5 V	10 A	S8PS-05005C	S8PS-05005CD	
			12 V	4.2 A	S8PS-05012C	S8PS-05012CD	
			24 V	2.1 A	S8PS-05024C	S8PS-05024CD	
		100 W	24 V	4.5 A	S8PS-10024C	S8PS-10024CD	
			150 W	24 V	6.5 A	S8PS-15024C	S8PS-15024CD
			300 W	24 V	14 A	S8PS-30024C	S8PS-30024CD
600 W	24 V	27 A	S8PS-60024C	---			
Open-frame type	100 to 240 VAC	50 W	5 V	10 A	S8PS-05005	S8PS-05005D	
			12 V	4.2 A	S8PS-05012	S8PS-05012D	
			24 V	2.1 A	S8PS-05024	S8PS-05024D	
		100 W	24 V	4.5 A	S8PS-10024	S8PS-10024D	
		150 W	24 V	6.5 A	S8PS-15024	S8PS-15024D	

Model Number Legend:

S8PS-□□□□□□□□

1 2 3

1. Power Ratings

050: 50 W
 100: 100 W
 150: 150 W
 300: 300 W
 600: 600 W

2. Output Voltage

05: 5 V
 12: 12 V
 24: 24 V

3. Configuration

C: Covered type with Front-mounting Bracket
 D: Open-frame type with DIN Track Mounting Bracket
 CD: Covered type with DIN Track Mounting Bracket
 None: Open-frame type with Front-mounting Bracket

Specifications

■ Ratings/Characteristics

Item		50 W	100 W	150 W	300 W	600 W
Efficiency (typical)		75 to 87% (depends on the model)				
Input	Voltage	100 to 240 VAC (85 to 264 VAC)				
	Frequency	47 to 450 Hz				
	Current (see note 1)	0.9 or 0.45 A max.	1.8 or 0.9 A max.	2.7 or 1.4 A max.	5.4 or 2.7 A max.	10 or 5 A max.
	Power factor (see note 1)	0.95 TYP.				
	Leakage current (see note 1)	0.5 or 1.0 mA max.				
	Inrush current (25°C, cold start) (see note 1)	25 or 50 A max.				
Output	Voltage adjustment range	-5% to 10%				
	Ripple (see note 1)	2% (p-p) max.				
	Input variation influence	0.4% max. (at 85 to 132 VAC input/at 170 to 264 VAC input, 100% load)				
	Load variation influence	0.8% max. (with rated input, 0 to 100% load)				
	Temperature variation influence (see note 1)	0.05%/°C max.				
	Rise time	1,000 ms max. (up to 90% of output voltage at rated output voltage/current)				
	Hold time (see note 1)	20 ms min.				
	Additional function	Overload protection	105% min., voltage trailing intermittent operation (With the 600-W model, output is turned OFF at 5 s min.)			
Overvoltage protection		Yes				
Overheat protection		No				Yes
Protection-ON alarm indicator		No			Yes (Red)	
Parallel operation		No			Yes, 2 units max.	
Other	Heat radiation	Natural air-cooling				Fan
	Ambient temperature	Operating: See the derating curve in the <i>Engineering Data</i> section. (with no condensation nor icing) Storage: -25°C to 65°C (with no condensation nor icing)				
	Ambient humidity	25% to 85%				
	Dielectric strength	3.0 kVAC, 50/60 Hz for 1 min (between all inputs and outputs) 2.2 kVAC, 50/60 Hz for 1 min (between all inputs and GR terminals) 1 kVAC, 50/60 Hz for 1 min (between all outputs and GR terminals)				
	Insulation resistance	100 MΩ min. (between all output and input/GR terminals at 500 VDC)				
	Vibration resistance	10 to 55 Hz, 0.75-mm amplitude for 2 h each in X, Y, and Z directions				
	Shock resistance	300 m/s ² (approx. 30G), 3 times each in ±X, ±Y, and ±Z directions				
	Output indicator	Yes (green)				
	Terminal screw tightening torque	1.08 N • m {11 kgf • cm} (see note 2)				
	Electromagnetic interference	Conforms to FCC Class B, EN50081-1				
	EMC	(EMI): EN50081-1 Emission Enclosure: EN55022 class B Emission AC Mains: EN55022 class B Harmonic Current: EN61000-3-2 (EMS): EN50082-2 Immunity ESD: EN61000-4-2: 4-kV contact discharge (level 2) 8-kV air discharge (level 3) Immunity RF-interference: ENV50140: 10 V/m (80 MHz to 1 GHz) (level 3) Immunity Conducted Disturbance: ENV50141: 10 V (0.15 to 80 MHz) (level 3) Immunity Burst: EN61000-4-4: 2-kV power-line (level 3) 2-kV output line (level 4) Immunity Surge: EN61000-4-5: between 3-kV lines between 4.5-kV line and FG				
	Approved standards	UL508, UL1012, CSA C22.2 No. 950, CSA C22.2 No. 14, EN60950, VDE0160. Conforms to UL1950 and CSA E.B. 1402C				
	Reliability (MTBF) (see note 3)	135,000 hrs min.				60,000 hrs min.
	Life expectancy (see note 4)	10 yrs. min. (Used at 40°C at the rated input with a 50% load, standard installation)				
	Weight (see note 5)	420 g max.	600 g max.	900 g max.	2,200 g max.	3,500 g max.
	Mounting method	Front-mounting Bracket or DIN Track Mounting Bracket				Front-mounting Bracket

- Note:**
- 100% load for rated input voltage (100 VAC or 200 VAC)
 - Do not press down on the terminal block with a force exceeding 75 N {7.6 kgf} while tightening the terminals.
 - MTBF stands for Mean Time Between Failures, which is calculated according to the probability of accidental device failures, and indicates reliability of devices. Therefore, it does not necessarily represent a life of the product.
 - The life expectancy shown in the above table indicates average operating hours under the ambient temperature of 40°C and a load rate of 50%. Normally this is determined by the life expectancy of the built-in aluminum electrolytic capacitor. It must be noted that the life expectancy of the fan built into the 600-W model is not included.
 - The weight indicated is for the open-frame type. (Includes the cover for 300-W and 600-W models.)

Engineering Data

Derating Curve

Open-frame Type

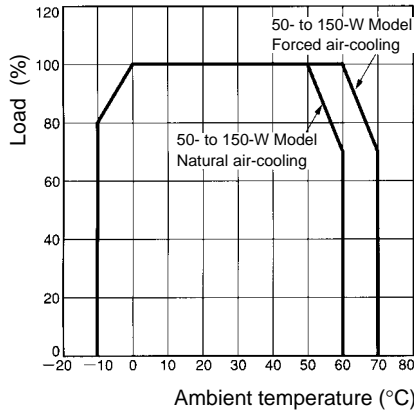

Covered Type

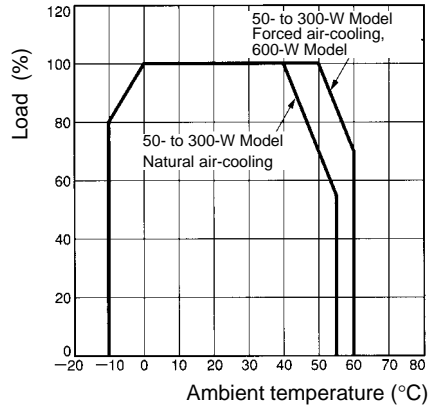

- Note:**
1. Forced air-cooling must be provided with an air volume of 1 m³/mm min.
 2. The derating curve shown is for standard installation. The derating curve depends on the mounting direction of the Power Supply.

Standard Installation 50-W Model

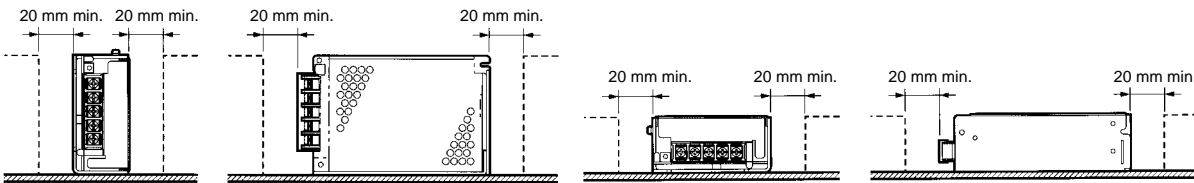

Standard Installation 100/150-W Model

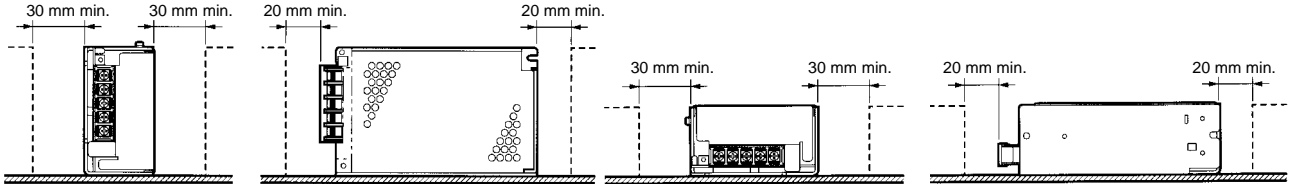

Standard Installation 300-W Model

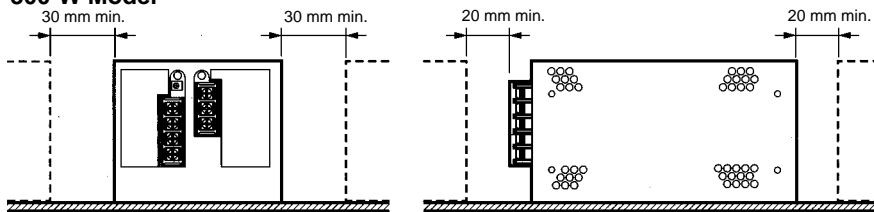

Standard Installation 600-W Model

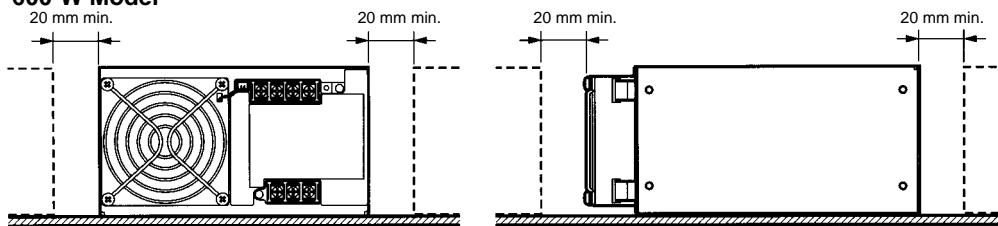

■ **Overload Protection**

50- to 300-W Models

The Power Supply is provided with an overload protection function that protects the load and the power supply from possible damage by overcurrent. The protection function operates when the load current rises above an overcurrent set value (105% of the rated load current). For a short-circuit or overcurrent lasting less than 20 seconds, output voltage is decreased to protect equipment. When the output current falls within the rated range, the overload protection function is automatically cleared.

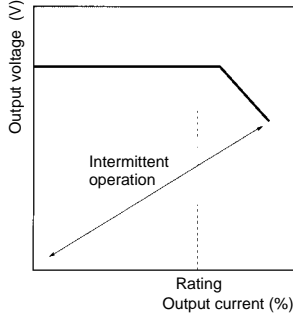

Note: Do not continue using the S8PS under short-circuited or overcurrent conditions for longer than 20 seconds, otherwise the internal elements of the S8PS may be damaged or broken.

600-W Models

If an excessive current flows for 5 s or more, the output will be turned OFF and simultaneously protection-ON alarm indicator will be lit. To reset the S8PS, turn OFF the input voltage, leave the S8PS for at least three minutes, and then apply the input voltage again.

Note: Do not continue using the S8PS with the output terminals short-circuited or the overcurrent condition continued, otherwise the internal elements of the S8PS may be damaged or broken.

■ **Overvoltage Protection**

The Power Supply is provided with an overvoltage protection function that protects the load and the Power Supply from possible damage by overvoltage. When the output voltage rises above a set value (115% of the rated output voltage), the protection function is triggered, shutting OFF the output voltage. If this occurs, reset the Power Supply by turning it OFF for 1 minute min. and then turning it ON again.

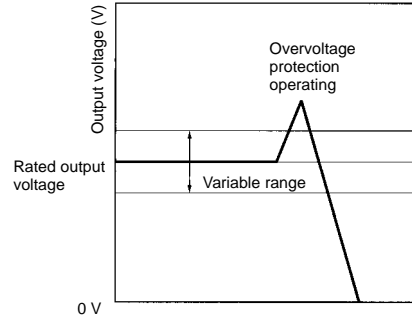

300- and 600-W Models Only

The overvoltage protection-ON alarm indicator lights when the function is operating.

■ **Overheat Protection Function**

600-W Model Only

If the internal temperature of the S8PS rises excessively as a result of fan failure or any other reason, the overheat protection circuit will be triggered to protect the internal elements of the S8PS and simultaneously a protection-ON alarm indicator will be lit. To reset the S8PS turn OFF the input voltage, leave the S8PS for at least one minute and then apply the input voltage again.

■ **Inrush Current, Rise Time, Hold Time**

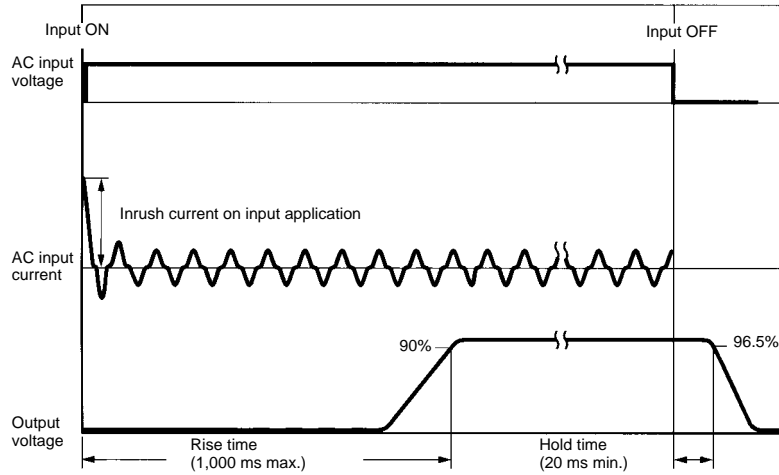

Operation

■ Block Diagrams

S8PS-050□□□□ (50 W)

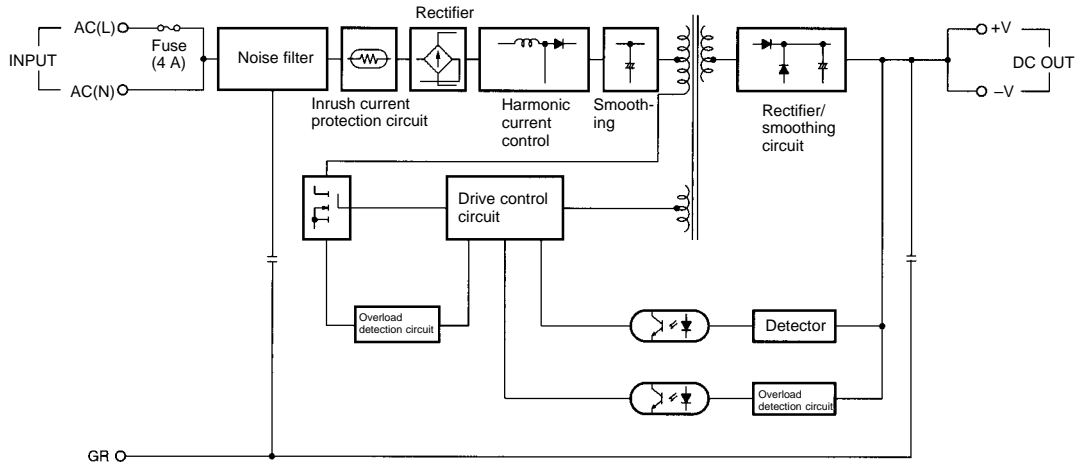

S8PS-10024□□ (100 W)

S8PS-15024□□ (150 W)

S8PS-30024□□ (300 W)

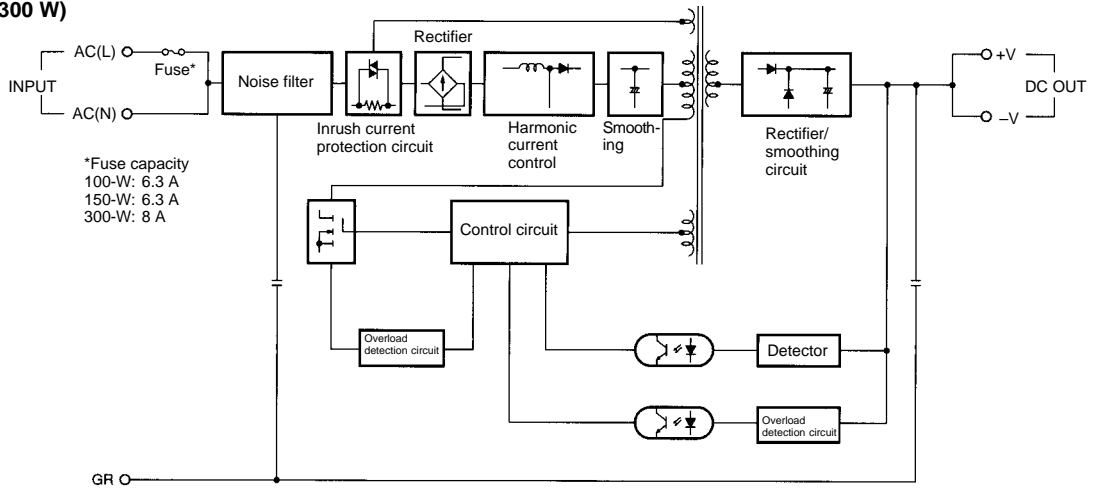

S8PS-60024C (600 W)

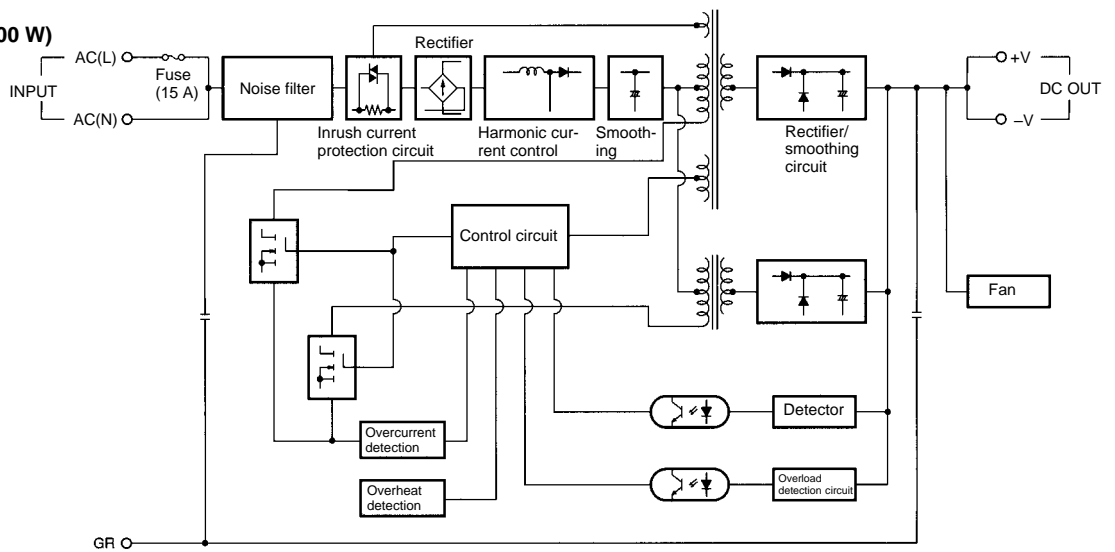

Dimensions

Note: All units are in millimeters unless otherwise indicated.

■ Front-mounting Bracket Type

The Front-mounting Bracket is provided as an accessory. Screws for fixing the Bracket to the panel are not provided.

S8PS-050□□ (50 W)

S8PS-050□□□C (50 W)

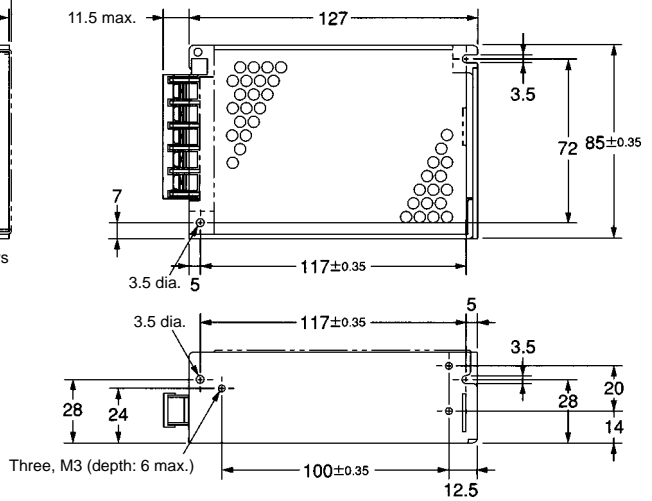
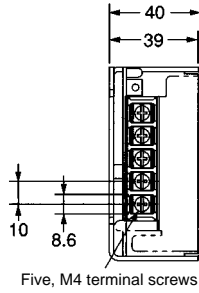
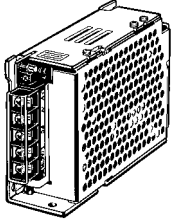

Front-mounting Bracket for 50-W Models

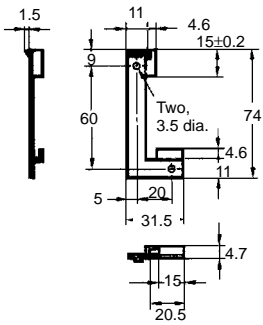

Mounting Holes

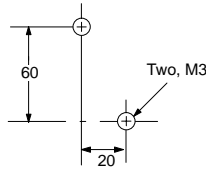

Using the Mounting Bracket

Attach the Mounting Bracket to the panel and loosely tighten the two screws. Insert the projected parts of the Bracket (b) to the square holes of the power supply (a). Then securely tighten the screws.

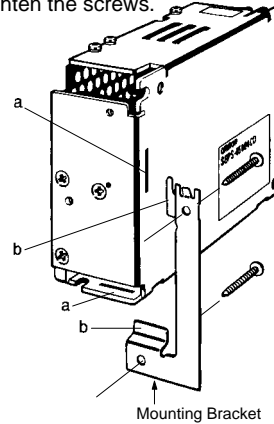

S8PS-10024 (100 W)

S8PS-10024C (100 W)

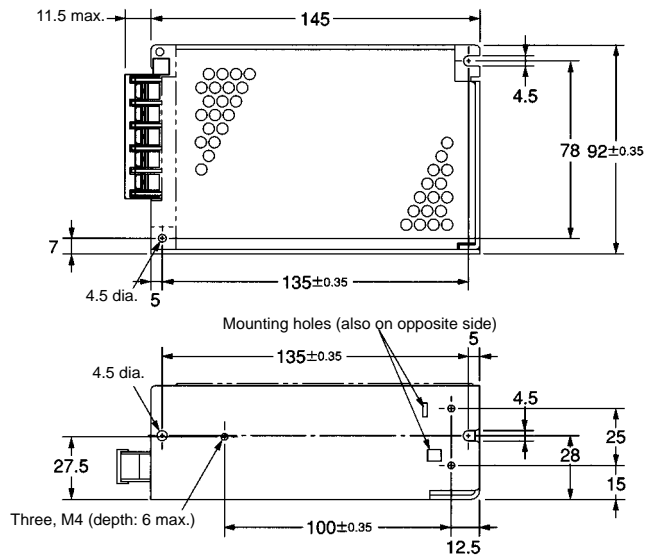
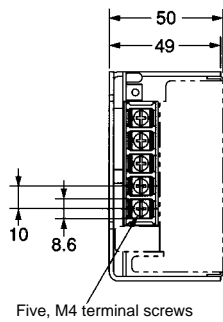
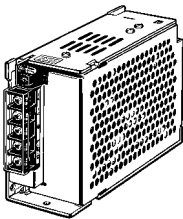

S8PS-15024 (150 W)
S8PS-15024C (150 W)

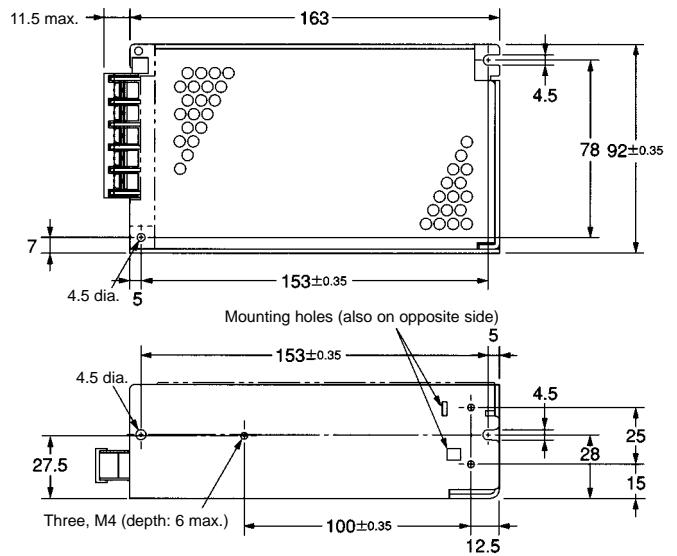
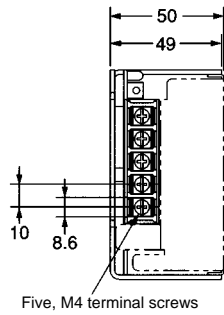
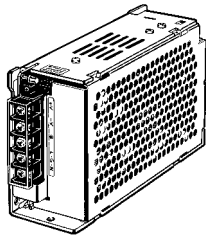

Front-mounting Bracket for 100/150-W Models

Appearance and Mounting Dimensions

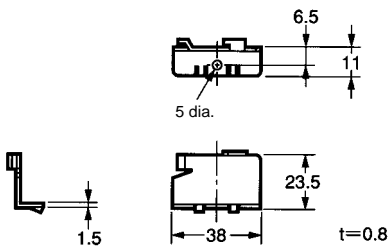

Dimensions with Mounting Bracket

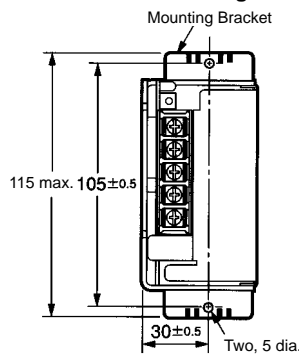

Using the Mounting Bracket

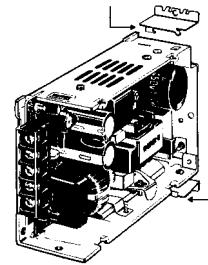

S8PS-30024C (300 W)

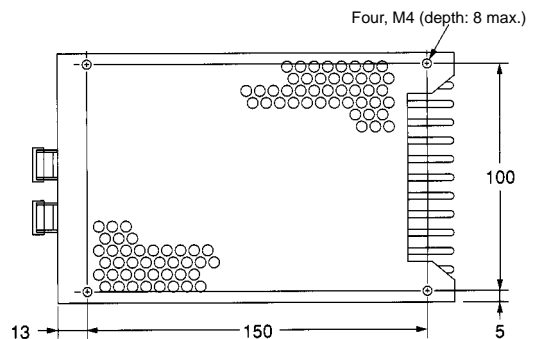
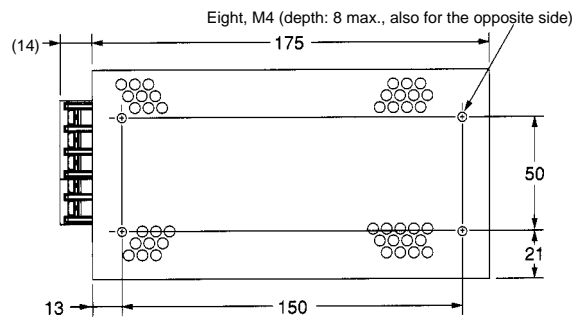
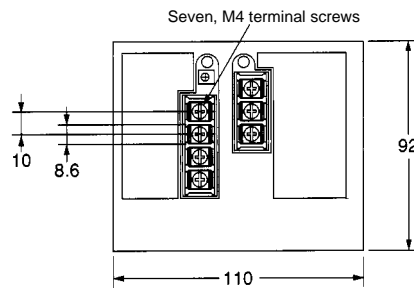
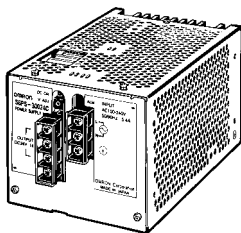

S8PS-60024C (600 W)

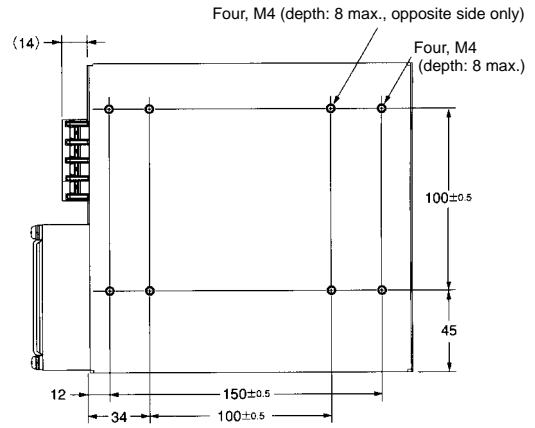
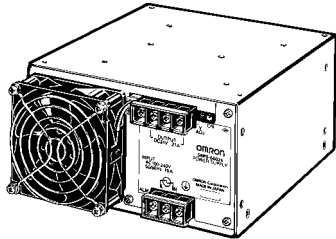
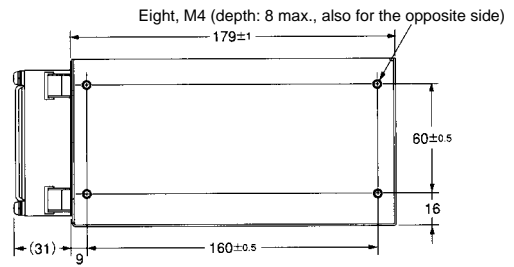
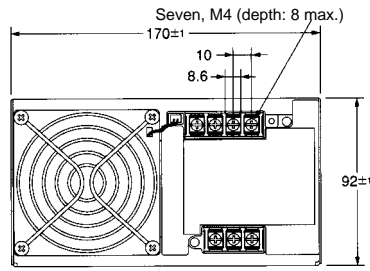

Front-mounting Bracket for 300/600-W Models

Appearance and Mounting Dimensions

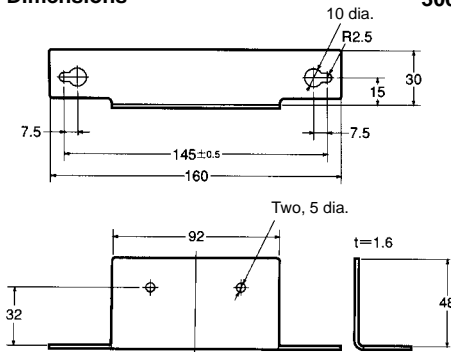

Dimensions with Mounting Bracket

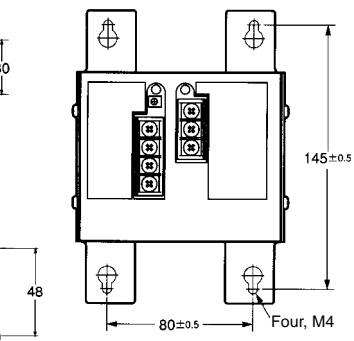

600-W models

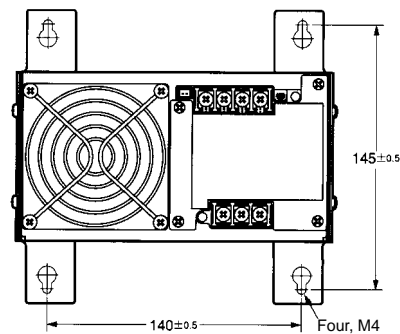

Using the Mounting Bracket

Note: Four screws for attaching the Bracket to the Power Supply Unit are provided.

300-W models

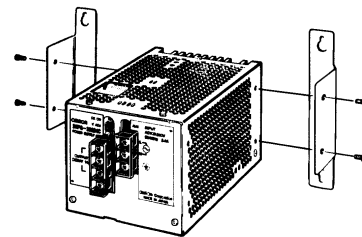

Note: Mount the Unit 21.6 mm away from the mounting surface in order to provide air ventilation on the rear side.

600-W models

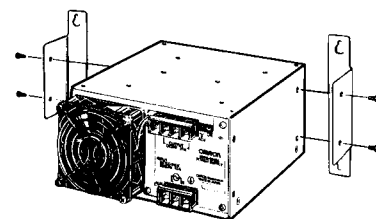

Note: Mount the Unit 28 mm away from the mounting surface in order to provide air ventilation on the rear side.

■ DIN Track Mounting Bracket Type

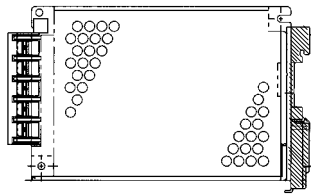

DIN Track Mounting Bracket

DIN Track Mounting Bracket is attached to the Power Supply Unit when the Unit is shipped.

S8PS-050□□D (50 W)
S8PS-050□□CD (50 W)

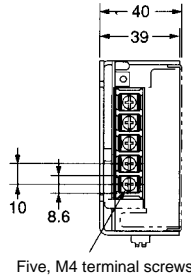
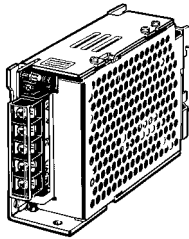

Five, M4 terminal screws

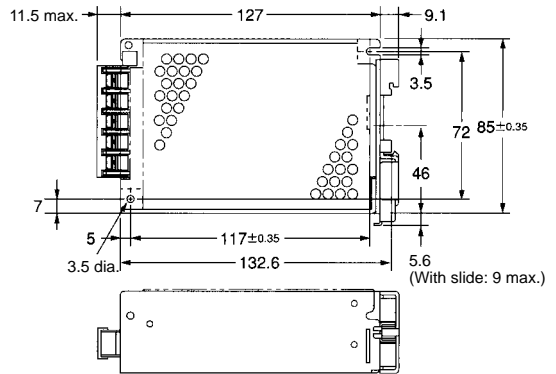

S8PS-10024D (100 W)
S8PS-10024CD (100 W)

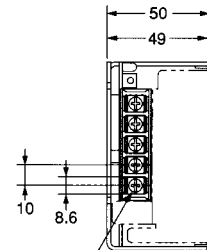
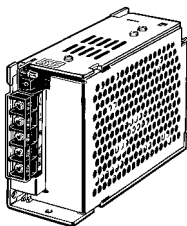

Five, M4 terminal screws

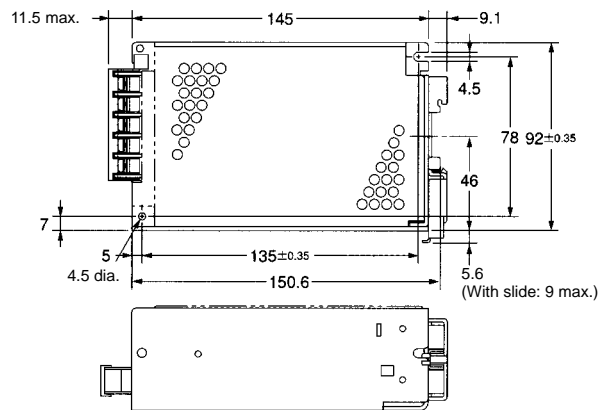

S8PS-15024D (150 W)
S8PS-15024CD (150 W)

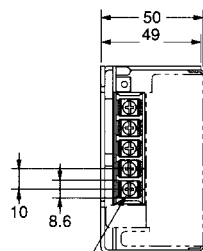
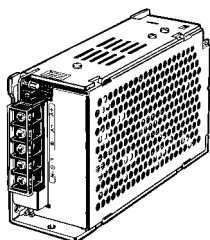

Five, M4 terminal screws

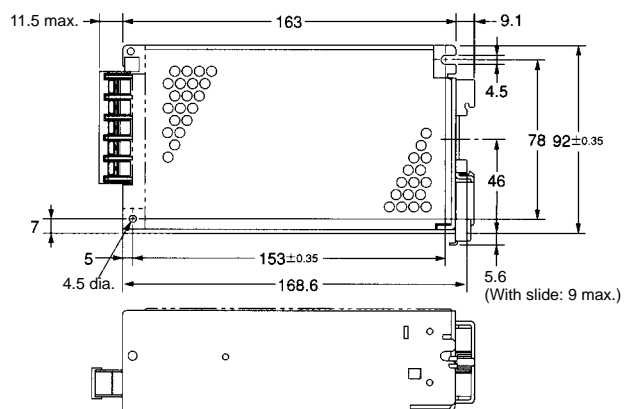

S8PS-30024CD (300 W)

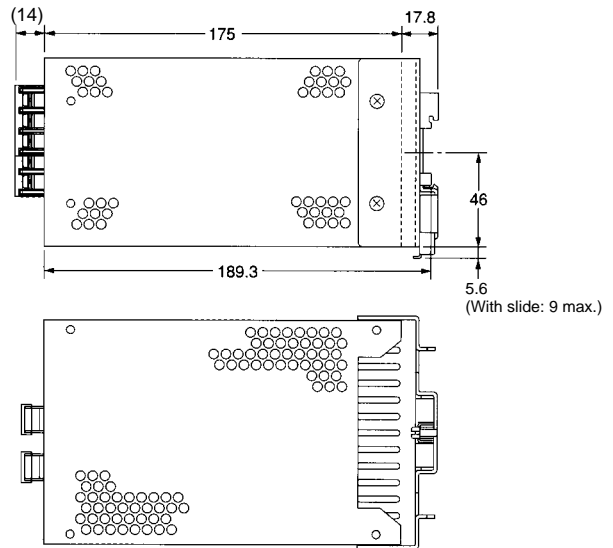
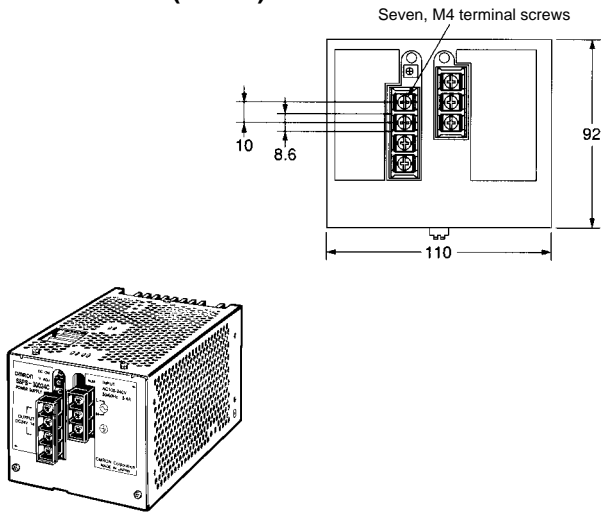

■ **Accessories**

Mounting Track (Order Separately)
PFP-100N/PFP-50N

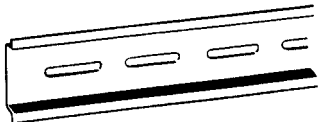

PFP-100N2

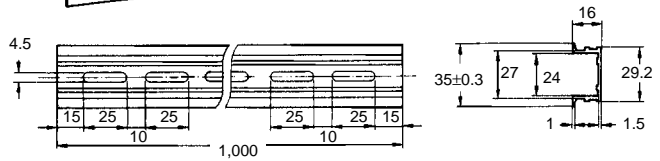
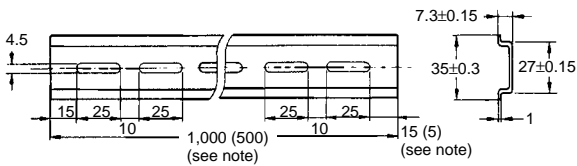
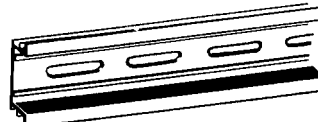

Note: The values shown in parentheses are for the PFP-50N.

Installation

50-W Models

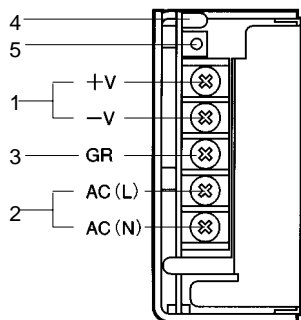

100-/150-W Models

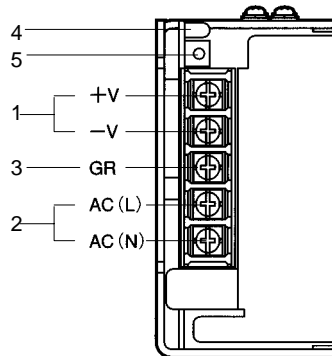

300-W Models

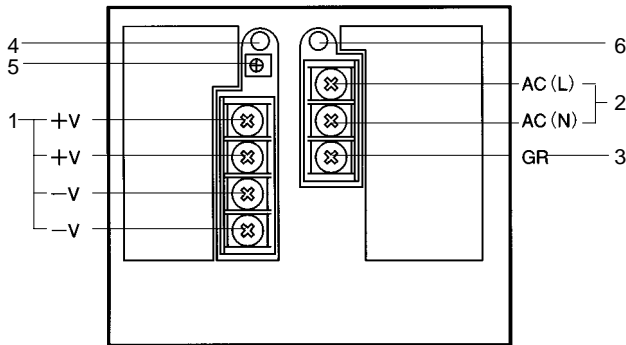

600-W Models

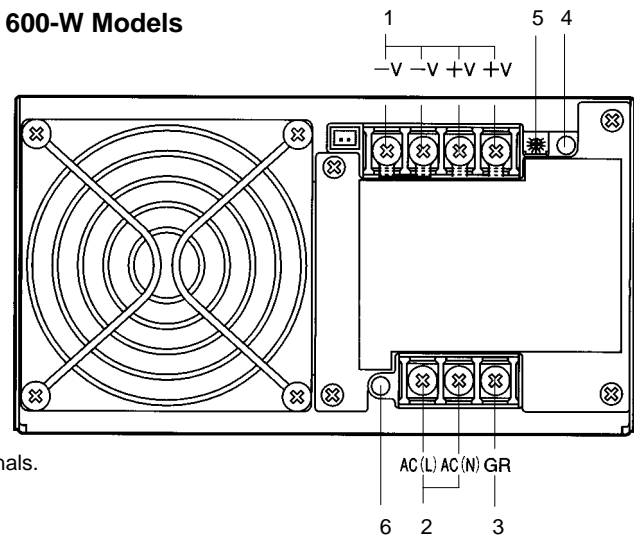

1. **DC Output Terminals:** Connect the load lines to these terminals.
2. **Input Terminals:** Connect the input lines to these terminals.
Note: A fuse is inserted into the AC (L) side.
3. **Ground Terminal (GR):** Connect a ground line to this terminal.
4. **Output Indicator (DC ON):** Lights while a Direct Current (DC) output is ON.
5. **Output Voltage Adjuster (V.ADJ):** It is possible to increase or decrease the output voltage by 10%.
6. **Protection-ON Alarm Indicator:** The red indicator will be lit if the overvoltage (for a 300-/600-W model) or overheat protection (for a 600-W model) circuit is triggered. This indicator will also be lit when overcurrent (for a 600-W model) is detected.

Precautions

**Caution**

Be sure to connect the grounding line. Not doing so may result in electric shock.

**WARNING**

Do not attempt to disassemble the Power Supply or touch its internal parts while power is being supplied. Doing so may result in electric shock.

Do not touch the terminals of the Power Supply within one minute after power has been turned OFF. Doing so may result in electric shock due to a residual voltage.

Do not touch the S8PS or heat radiation fin while the power is being supplied or immediately after the power is turned OFF. Otherwise, a skin burn may result from the hot Switching Power Supply or radiator.

Mounting

To improve and maintain the reliability of the Power Supply over a long period of time, adequate consideration must be given to heat radiation.

The Power Supply is designed to radiate heat by means of natural air-flow. Therefore, mount the Power Supply so that air flow takes place around the Power Supply.

When mounting the Power Supply, mounting it to a metal plate is recommended.

Forced air-cooling is highly recommended.

It is recommended that the clearance around the Power Supply be larger than those shown on page 3 under *Standard Installation*.

Generating Output Voltage (\pm)

An output of \pm can be generated by using two Power Supplies as shown below, because the Power Supply produces a floating output.

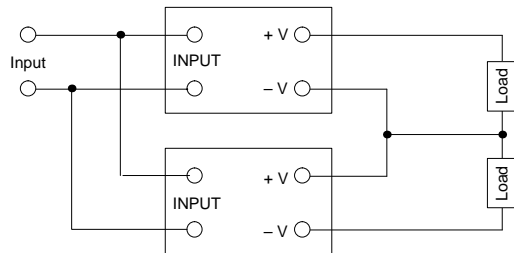
**Series Operation**

Only models with power ratings of 100/150 W allow series operation.

As shown in the following diagram, the output voltage from each Switching Power Supply can be added.

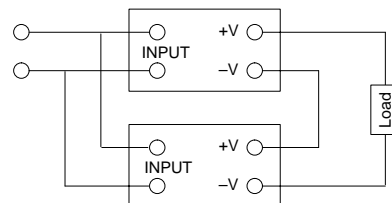

Parallel Operation

Only 300- and 600-W models can be in parallel operation provided that they are operated under 90% of the ratings. Do not operate any other models in parallel.

Make sure that the thickness and the length of all wires connected to the load are the same to ensure that the wires will have no voltage drop differences.

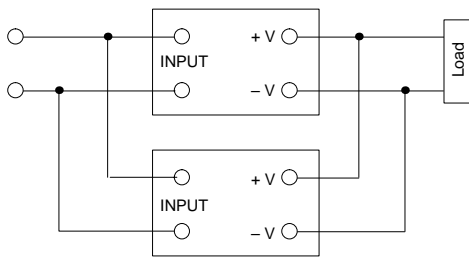

Fan Set:

Fan (above), four M4 x 35 sems screws, instruction sheet, and packing case

Replace the fan as shown in the following illustration.

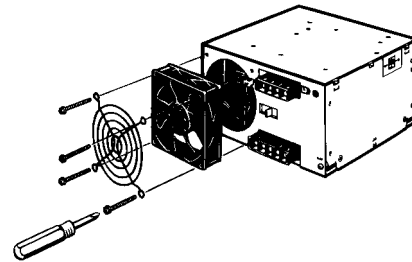

Fan Replacement

The service life of the fan is approximately 50,000 hours (at 25°C). The service life varies, however, depending on the ambient temperature or other surrounding environmental conditions such as dust. As a preventive maintenance measure, replace the fan within two years if it is used at an ambient temperature of 40°C.

Fans are available as replacements.

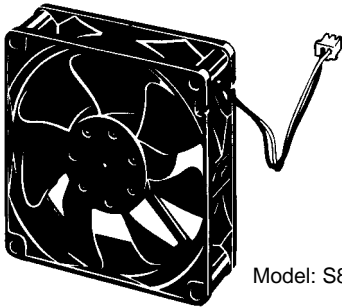

Model: S82Y-JFAN

ALL DIMENSIONS SHOWN ARE IN MILLIMETERS.

To convert millimeters into inches, multiply by 0.03937. To convert grams into ounces, multiply by 0.03527.

Cat. No. T021-E1-2A In the interest of product improvement, specifications are subject to change without notice.

OMRON Corporation

Industrial Automation Company

Measuring and Supervisory Controls Department
Shiokoji Horikawa, Shimogyo-ku,
Kyoto, 600-8530 Japan
Tel: (81)75-344-7108/Fax: (81)75-344-7189

Printed in Japan
0501-0.3M (1198)