

ITBC-CST01
CS1 Bus Interface Board

Operation Manual

Produced September 2000

Notice:

OMRON products are manufactured for use according to proper procedures by a qualified operator and only for the purposes described in this manual.

The following conventions are used to indicate and classify precautions in this manual. Always heed the information provided with them. Failure to heed precautions can result in injury to people or damage to property.

 **DANGER** Indicates an imminently hazardous situation which, if not avoided, will result in death or serious injury.

 **WARNING** Indicates a potentially hazardous situation which, if not avoided, could result in death or serious injury.

 **Caution** Indicates a potentially hazardous situation which, if not avoided, may result in minor or moderate injury, or property damage.

OMRON Product References

All OMRON products are capitalized in this manual. The word “Unit” is also capitalized when it refers to an OMRON product, regardless of whether or not it appears in the proper name of the product.

The abbreviation “Ch,” which appears in some displays and on some OMRON products, often means “word” and is abbreviated “Wd” in documentation in this sense.

The abbreviation “PLC” means Programmable Controller.

Visual Aids

The following headings appear in the left column of the manual to help you locate different types of information.

Note Indicates information of particular interest for efficient and convenient operation of the product.

1, 2, 3... 1. Indicates lists of one sort or another, such as procedures, checklists, etc.

© OMRON, 2000

All rights reserved. No part of this publication may be reproduced, stored in a retrieval system, or transmitted, in any form, or by any means, mechanical, electronic, photocopying, recording, or otherwise, without the prior written permission of OMRON.

No patent liability is assumed with respect to the use of the information contained herein. Moreover, because OMRON is constantly striving to improve its high-quality products, the information contained in this manual is subject to change without notice. Every precaution has been taken in the preparation of this manual. Nevertheless, OMRON assumes no responsibility for errors or omissions. Neither is any liability assumed for damages resulting from the use of the information contained in this publication.

TABLE OF CONTENTS

| | |
|--|-----------|
| PRECAUTIONS | xi |
| 1 Intended Audience | xii |
| 2 General Precautions | xii |
| 3 Safety Precautions | xii |
| 4 Operating Environment Precautions | xii |
| 5 Application Precautions | xiii |
| SECTION 1 | |
| Introduction | 1 |
| 1-1 Functions | 2 |
| 1-2 Products | 3 |
| SECTION 2 | |
| Hardware Settings | 5 |
| 2-1 Nomenclature and Functions | 6 |
| 2-2 Unit Number Setting | 6 |
| 2-3 Mounting the CS1 Bus Interface Board | 7 |
| 2-4 I/O Connecting Cable | 7 |
| Appendices | |
| A Specifications | 9 |
| B Dimensions | 11 |
| Revision History | 13 |

About this Manual:

This manual describes the installation and operation of the ITBC-CST01 CS1 Bus Interface Board and includes the sections described below. The CS1 Bus Interface Board is installed in a personal computer to connect the computer to a CS1-series PC via the CS1 bus.

Please read this manual carefully and be sure you understand the information provided before attempting to install and operate a CS1 Bus Interface Board.

Section 1 describes the functions and configuration of the CS1 Bus Interface Board.

Section 2 describes the hardware settings required to used the CS1 Bus Interface Board.

The **Appendices** provide CS1 Bus Interface Board specifications and dimensions.



WARNING Failure to read and understand the information provided in this manual may result in personal injury or death, damage to the product, or product failure. Please read each section in its entirety and be sure you understand the information provided in the section and related sections before attempting any of the procedures or operations given.

PRECAUTIONS

This section provides general precautions for using the CS1 Bus Interface Board and related devices.

The information contained in this section is important for the safe and reliable application of the CS1 Bus Interface Boards. You must read this section and understand the information contained before attempting to set up or operate a CS1 Bus Interface Board.

| | |
|---|------|
| 1 Intended Audience | xii |
| 2 General Precautions | xii |
| 3 Safety Precautions | xii |
| 4 Operating Environment Precautions | xii |
| 5 Application Precautions | xiii |

1 Intended Audience

This manual is intended for the following personnel, who must also have knowledge of electrical systems (an electrical engineer or the equivalent).

- Personnel in charge of installing FA systems.
- Personnel in charge of designing FA systems.
- Personnel in charge of managing FA systems and facilities.

2 General Precautions

The user must operate the CS1 Bus Interface Board according to the performance specifications described in the operation manuals.

Before using a CS1 Bus Interface Board under conditions which are not described in the manual or applying a CS1 Bus Interface Board to nuclear control systems, railroad systems, aviation systems, vehicles, combustion systems, medical equipment, amusement machines, safety equipment, and other systems, machines, and equipment that may have a serious influence on lives and property if used improperly, consult your OMRON representative.

Make sure that the ratings and performance characteristics of the CS1 Bus Interface Board are sufficient for the systems, machines, and equipment, and be sure to provide the systems, machines, and equipment with double safety mechanisms.

This manual provides information for programming and operating the CS1 Bus Interface Board. Be sure to read this manual before attempting to use a CS1 Bus Interface Board and keep this manual close at hand for reference during operation.

 **WARNING** It is extremely important that a CS1 Bus Interface Board be used for the specified purpose and under the specified conditions, especially in applications that can directly or indirectly affect human life. You must consult with your OMRON representative before applying a CS1 Bus Interface Board System to the above-mentioned applications.

3 Safety Precautions

 **WARNING** Do not attempt to take a CS1 Bus Interface Board apart while the power is being supplied. Doing so may result in electric shock.

 **WARNING** Fail-safe measures must be taken by the customer to ensure safety in the event of incorrect, missing, or abnormal signals caused by broken signal lines, momentary power interruptions, or other causes.

4 Operating Environment Precautions

 **Caution** Do not operate the control system in the following locations:

- Locations subject to direct sunlight.
- Locations subject to temperatures or humidity outside the range specified in the specifications.
- Locations subject to condensation as the result of severe changes in temperature.
- Locations subject to corrosive or flammable gases.

- Locations subject to dust (especially iron dust) or salts.
- Locations subject to exposure to water, oil, or chemicals.
- Locations subject to shock or vibration.

 **Caution** Install the CS1 Bus Interface Boards properly as specified in the operation manuals. Improper installation of the CS1 Bus Interface Boards may result in malfunction.

 **Caution** Take appropriate and sufficient countermeasures when installing systems in the following locations:

- Locations subject to static electricity or other forms of noise.
- Locations subject to strong electromagnetic fields.
- Locations subject to possible exposure to radioactivity.
- Locations close to power supplies.

 **Caution** The operating environment of the CS1 Bus Interface Board System will have a large effect on the longevity and reliability of the system. Improper operating environments can lead to malfunction, failure, and other unforeseeable problems with the CS1 Bus Interface Board System. Be sure that the operating environment is within the specified conditions at installation and remains within the specified conditions during the life of the system.

5 Application Precautions

Observe the following precautions when using the CS1 Bus Interface Board System.

- Always use the power supply voltages specified in the operation manuals. An incorrect voltage may result in malfunction or burning.
- Take appropriate measures to ensure that the specified power with the rated voltage and frequency is supplied. Be particularly careful in places where the power supply is unstable. An incorrect power supply may result in malfunction.
- Install external breakers and take other safety measures against short-circuiting in external wiring. Insufficient safety measures against short-circuiting may result in burning.
- Always turn OFF the power supply to the CS1 Bus Interface Board and the PLC before attempting any of the following. Not turning OFF the power supply may result in malfunction or electric shock.
 - Mounting or dismounting I/O Units or any other Units.
 - Assembling the Units.
 - Setting DIP switches or rotary switches.
 - Connecting cables or wiring the system.
 - Connecting or disconnecting the connectors.
- Do not attempt to disassemble, repair, or modify any Units.
- The mounting screws of the CS1 Bus Interface Board must be tightened to the torque specified in the manuals for the personal computer. Incorrect tightening torque may result in malfunction.
- Double-check all wiring and switch settings before turning ON the power supply. Incorrect wiring may result in burning.
- Be sure that the connectors, expansion cables, and other items with locking devices are properly locked into place. Improper locking may result in malfunction.

- Check the user program for proper execution before actually executing it. Not checking the program may result in unexpected operation.
- Do not pull on cables or bend them past their natural bending radius. Doing so may damage the cables and interfere with proper operation.
- Do not place any objects on the cables.
- The PC will not start operation even after the power supply is turned ON until the CS1 Bus Interface Board completes initialization. The time required for initialization depends on the computer in which the Board is installed, You must design the system to allow for this delay.
- Also, if the power supply to the Open Network Controller is interrupted during operation, the PC will detect an I/O bus error. You must design the system to allow for this possibility.

SECTION 1

Introduction

This section describes the functions and configuration of the CS1 Bus Interface Board.

| | | |
|-------|--|---|
| 1-1 | Functions | 2 |
| 1-1-1 | Functions and Connections with CS1 | 2 |
| 1-1-2 | Precautions for System Design | 2 |
| 1-2 | Products | 3 |

1-1 Functions

1-1-1 Functions and Connections with CS1

The ITBC-CST01 CS1 Bus Interface Board is a PCI board that is installed in a personal computer to connect the computer to a CS1-series PC via the I/O bus.

As shown below, the Board is connected to either the CPU Rack or CS1 Expansion Rack. The personal computer functions as a CS1 CPU Bus Unit to enable I/O communications with the PC.

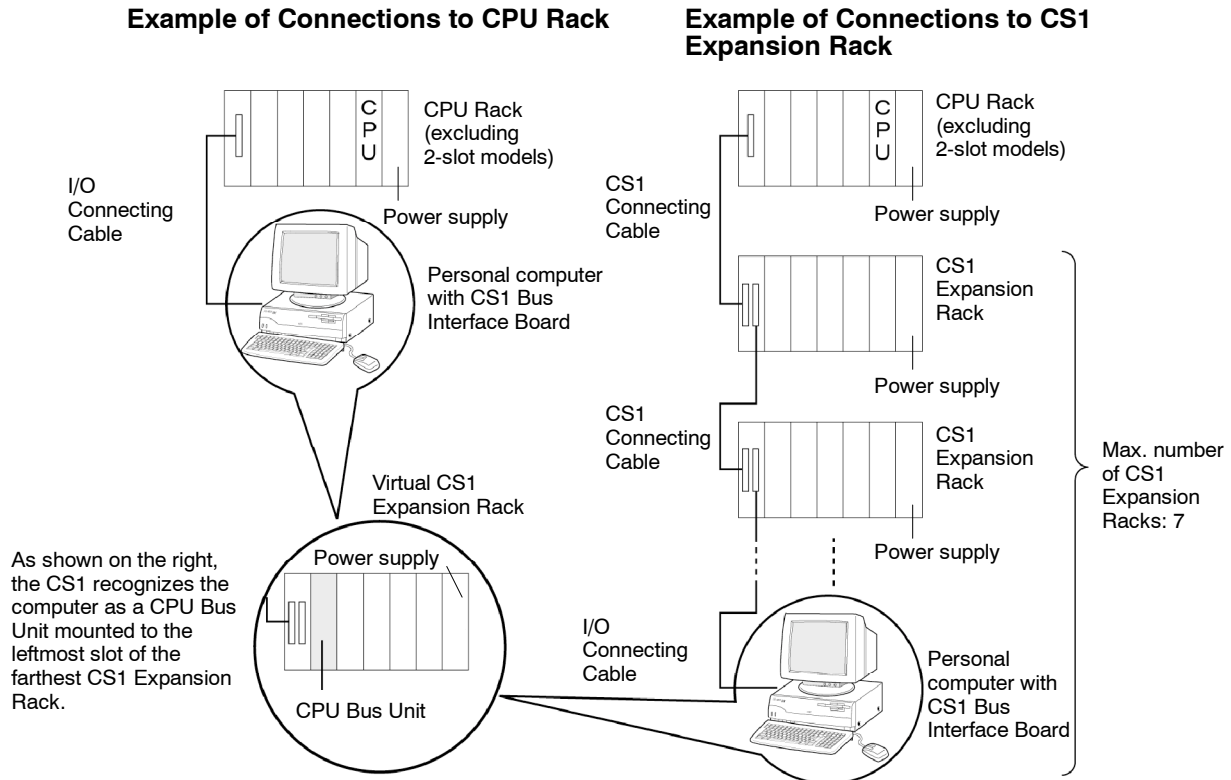

- Note**
1. Connect the computer to the last CS1 Expansion Rack.
 2. The computer is treated as one CS1 Expansion Rack, and it must be counted as one CS1 Expansion Rack when calculating the maximum number of connectable CS1 Expansion Racks.
 3. The maximum available cable length including the length of the I/O Connecting Cable is 12 m.
 4. The computer cannot be connected to a C200H Rack.

1-1-2 Precautions for System Design

- The PC will not start operation even after the power supply is turned ON until the CS1 Bus Interface Board completes initialization. The time required for initialization depends on the computer in which the Board is installed, You must design the system to allow for this delay.

1-2 Products

ITBC-CST01 CS1 Bus Interface Board

The ITBC-CST01 Standard Model is shown below. Use the illustration to confirm you have the correct model.

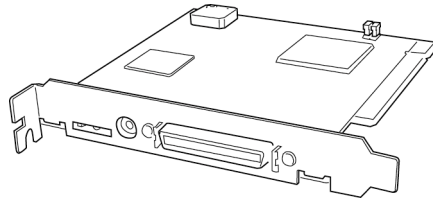

| |
|--------------------|
| |
| Safety Precautions |
| |

Safety Precautions

The ITBC-CN□□□-CST is shown below. Use the illustration to confirm you have the correct model. The cable length varies with the model as listed in the following table.

| Model | Length |
|----------------|--------|
| ITBC-CN001-CST | 1 m |
| ITBC-CN005-CST | 5 m |
| ITBC-CN012-CST | 12 m |

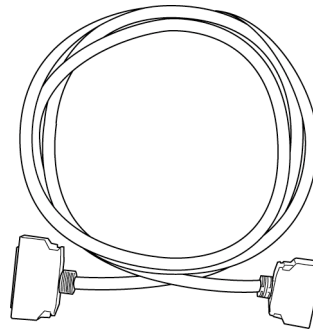

SECTION 2

Hardware Settings

This section describes the hardware settings required to used the CS1 Bus Interface Board.

| | | |
|-----|--|---|
| 2-1 | Nomenclature and Functions | 6 |
| 2-2 | Unit Number Setting | 6 |
| 2-3 | Mounting the CS1 Bus Interface Board | 7 |
| 2-4 | I/O Connecting Cable | 7 |

2-1 Nomenclature and Functions

The names and functions of the components of the CS1 Bus Interface Board are shown below.

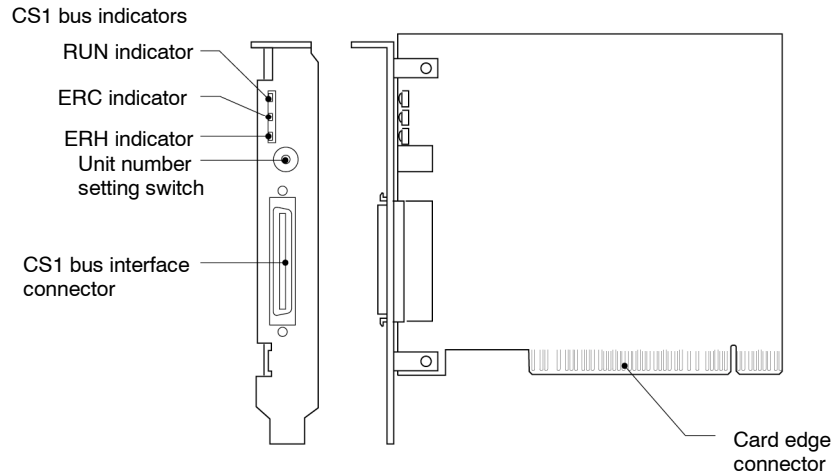

| Name | Function |
|-----------------------------|---|
| CS1 bus indicators | The indicators show the status of the CS1 bus. Refer to <i>CS1 Bus Indicators</i> for details. |
| Unit number setting switch | Use this switch to set the Unit number of the personal computer (as a CPU Bus Unit) for CS1 bus connections. Refer to <i>1-1 Functions</i> for information on the CPU Bus Unit. |
| CS1 bus interface connector | Connect the I/O connecting cable to the connector. |
| Card edge connector | Connect the the PCI bus connector in the personal computer. |

CS1 Bus Indicators

The following table provides information on the CS1 bus indicator.

| Indicator | Name | Color | Status | Meaning |
|-----------|------------------|-------|---------|------------------------------------|
| RUN | Operating | Green | Lit | The CPU Bus Unit is operating. |
| | | | Not lit | The CPU Bus Unit is not operating. |
| ERC | Controller error | Red | Lit | The CPU Bus Unit has an error. |
| | | | Not lit | The CPU Bus Unit has no errors. |
| ERH | PLC error | Red | Lit | The CS1 CPU Unit has an error. |
| | | | Not lit | The CS1 CPU Unit has no errors. |

2-2 Unit Number Setting

Use the Unit number setting switch to set the Unit number of the personal computer (as a CPU Bus Unit) for CS1 bus connections.

Note Refer to *1-1 Functions* for details on CPU Bus Units.

Set the Unit number to between 0 and F (i.e., 0 and 15). Check that the Unit number is not used by any other CPU Bus Unit, such as an Ethernet Unit or Controller Link Unit.

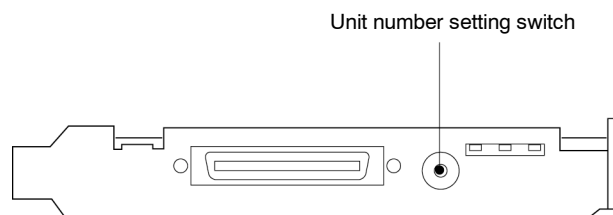

2-3 Mounting the CS1 Bus Interface Board

Mount the CS1 Bus Interface Board to a PCI bus connector in the personal computer.

Note

Turn OFF the power supply to the personal computer before starting the procedure to mount the Board.

1, 2, 3...

1. Insert the CS1 Bus Interface Board into the PCI bus connector in the personal computer, making sure it is in the correct orientation.
2. Secure the CS1 Bus Interface Board with the screws provided with the personal computer.

2-4 I/O Connecting Cable

Use an I/O Connecting Cable to connect the personal computer to the CS1 CPU Rack or CS1 Expansion Rack.

Note

Turn OFF the PC and the personal computer before connecting the I/O Connecting Cable.

1, 2, 3...

1. As shown below, connect the smaller connector (50-pin connector) of the I/O Connecting Cable to the CS1 bus interface connector on the CS1 Bus Interface Board.
2. Connect the larger connector (68-pin connector) of the I/O Connecting Cable to the expansion connector on the CS1 CPU Rack or CS1 Expansion Rack.

Note

When the CS1 Expansion Rack is used, connect the cable to the OUT connector on the last CS1 Expansion Rack.

Appendix A

Specifications

This appendix lists the specifications of the CS1 Bus Interface Unit. Other specifications confirm to those of the SYSMAC CS1-series PCs.

| Item | Specifications |
|----------------------|---------------------------------|
| Model | ITBC-CST01 |
| Current consumption | 0.2 A max. |
| Weight | 0.1 kg max. |
| Power supply voltage | 4.875 to 5.25 VDC |
| Dimensions | 163.0 x 106.7 x 18.5 mm (WxDxH) |

Appendix B

Dimensions

The dimensions of the CS1 Bus Interface Board are shown below. All dimensions are in millimeters.

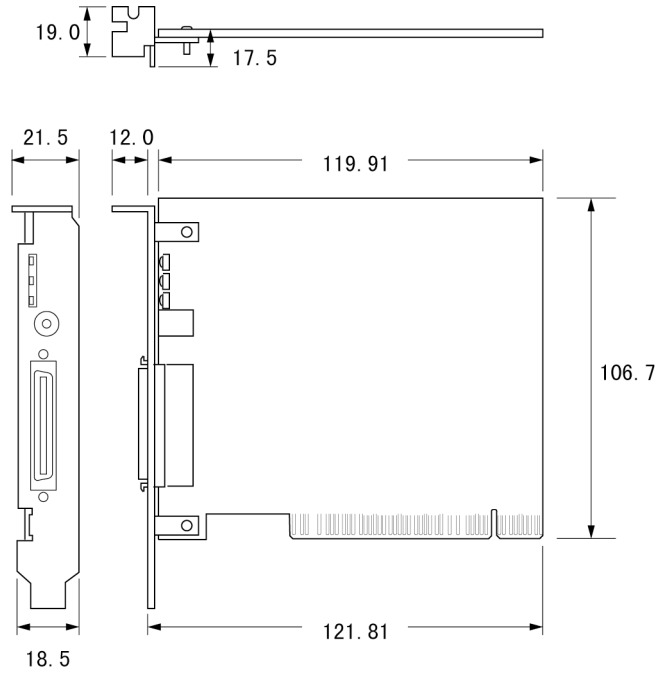

Revision History

A manual revision code appears as a suffix to the catalog number on the front cover of the manual.

Cat. No. V211-E1-1

↑
└── Revision code

The following table outlines the changes made to the manual during each revision. Page numbers refer to the previous version.

| Revision code | Date | Revised content |
|---------------|----------------|---------------------|
| 1 | September 2000 | Original production |