

Model

CPM1A-MAD01

ANALOG INPUT/OUTPUT UNIT

INSTRUCTION SHEET

Thank you for purchasing an OMRON product. Read this thoroughly and familiarize yourself with the functions and characteristics of the product before using it. Keep this instruction sheet for future reference.

© OMRON Manufacturing of the Netherlands b.v. 1997
All rights reserved

000207N-3B

Terminals for external wiring

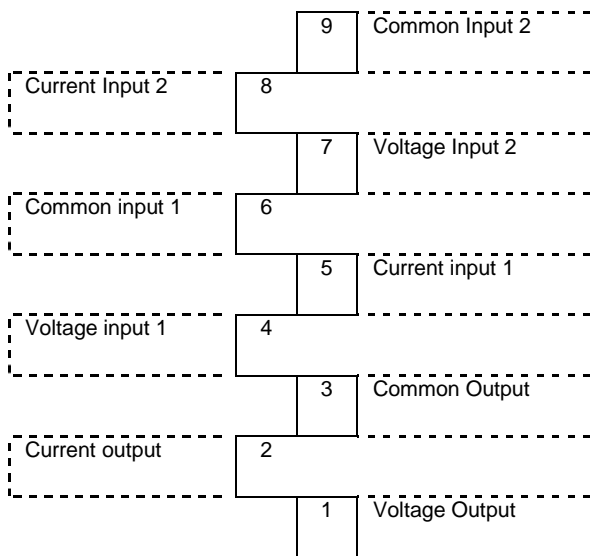

Specifications

Number of analog outputs	1	
Output signal range	Voltage output	0V to +10V -10V to +10V
	Current output	4mA to 20mA
Resolution	Voltage output	1/256 (0V to +10V) 1/512 (-10V to +10V)
	Current output	1/256
Accuracy	Voltage output	1.0% max. (full scale)
	Current output	1.0% max. (full scale)
Number of analog inputs	2	
Input signal range	Voltage input	0V to +10V +1V to +5V
	Current input	4mA to 20mA
Resolution	Voltage input	1/256
	Current input	1/256
Accuracy	Voltage input	1.0% max. (full scale)
	Current input	1.0% max (full scale)
Max. Input signals	Voltage input	±15V continuous
	Current input	30mA continuous
Conversion time (See Note.)	10ms. max. / Unit	
Max. output current	Voltage output	5mA
Max. load resistance	Current output	350Ω
Max. total output current (Unit)	21mA	
PC signal	Voltage output	8-bit binary + sign bit (80FF to 0000 to 00FF hexadecimal)
	Current output	8-bit binary (0000 to 00FF hexadecimal)
External connections	9-pin terminal block (non-removable)	
Insulation	Between output/input terminals and PC : photocouplers	
	Between output terminals individual : none	
Power consumption	60mA max. (5VDC) 60mA max. (24VDC)	
Dimensions	66(W) x 50(H) x 90(D) mm	
Weight	150 gram max.	

Note This is the time for a complete refresh of inputs and outputs of the unit.

- Voltage output and current output can be used simultaneously as long as the total output current is 21mA or less.
- Data written to the output channel is valid for current and voltage output.
- Data read from the input channels is valid for current or voltage input.

Setting the ranges

After starting up, you have to set the ranges. These ranges can be set by writing FF0x to the output channel of the CPM1A-MAD01 (see table below).

Range set code	OUTPUT	INPUT 1	INPUT 2
FF00	0 to 10 V 4 to 20mA	0 to 10 V	0 to 10 V
FF01	-10 to 10 V 4 to 20mA	0 to 10 V	0 to 10 V
FF02	0 to 10 V 4 to 20mA	1 to 5 V 4 to 20mA	0 to 10 V
FF03	-10 to 10 V 4 to 20mA	1 to 5 V 4 to 20mA	0 to 10 V
FF04	0 to 10 V 4 to 20mA	0 to 10 V	1 to 5 V 4 to 20mA
FF05	-10 to 10 V 4 to 20mA	0 to 10 V	1 to 5 V 4 to 20mA
FF06	0 to 10 V 4 to 20mA	1 to 5 V 4 to 20mA	1 to 5 V 4 to 20mA
FF07	-10 to 10 V 4 to 20mA	1 to 5 V 4 to 20mA	1 to 5 V 4 to 20mA

NOTE Always start with setting the ranges after power up otherwise the CPM1A-MAD01 will not convert any input or output.

Channel allocation:

CPU	Output channel MAD01	Input channel 1 MAD01	Input channel 2 MAD01
10CDR	11	1	2
20CDR	11	1	2
30CDR	12	2	3

IR bit allocation:

15	14	13	12	11	10	9	8	7	6	5	4	3	2	1	0
s/b	x	x	x	x	x	x	x	d	d	d	d	d	d	d	d
Not used (0)								databits							
s: sign bit¹															
0		positive voltage output													
1		negative voltage output													
b: broken wire bit²															
0		no broken wire													
1		broken wire													

1. The sign bit is only valid when the range is set to -10V to +10V.
2. Broken wire bit will be set in the 1-5V/4-20mA input range when the input voltage/current is below 1V/4mA.

Output wiring:

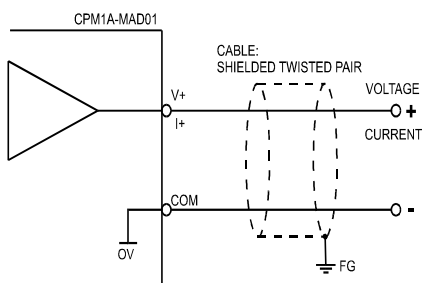

Input wiring:

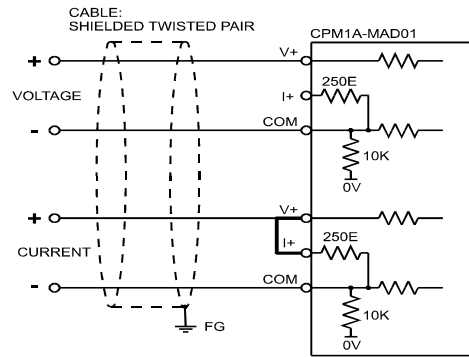

#Data

Output

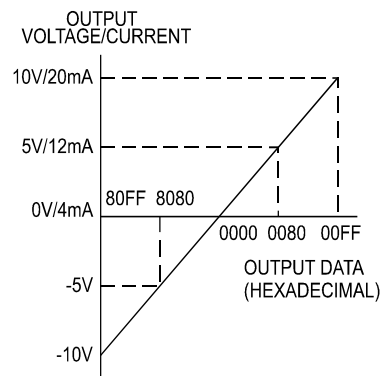

Input

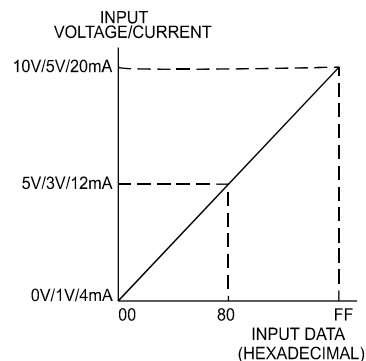

Dimensions

