

+New

OMRON

Linear Sensor Indicator

K3HB-S

Visual clarity and instantaneous measurement.
Control status and judgement results can be ascertained
at a glance using the display color and position meter.



**Innovation
in the Solution Age**

OMRON INDUSTRIAL AUTOMATION

Features

Intelligent

- **High-speed Response at 2,000 Times per Second**

Capable of high-speed sampling at 2,000 times/second. Peak-hold and bottom-hold functions allow accurate measurement of peak and bottom values.

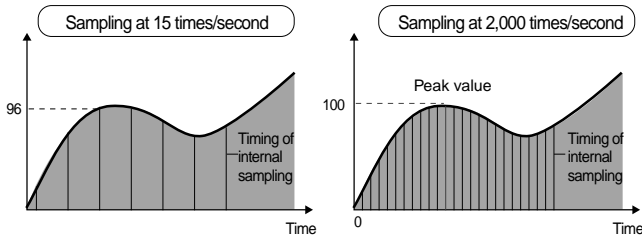

- **Calculations Based on Two Input Signals**

Calculations, such as $K-A$, $A+B$, $A-B$, and $K-(A+B)$, can be performed on two analog input signals. This enables highly precise thickness and level-difference measurement. The input ranges can be set independently so, for example, signals between 4 and 20 mA can be handled by one input while signals between 1 and 5 V are handled by the other.

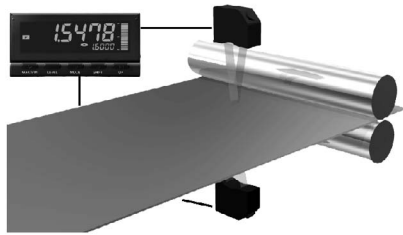

- **A Wide Variety of Measurement Functions Including Timing Signal Input**

Choose the input processing method suitable for the application from a selection of five measurement modes, such as sampling hold, peak hold, and bottom hold.

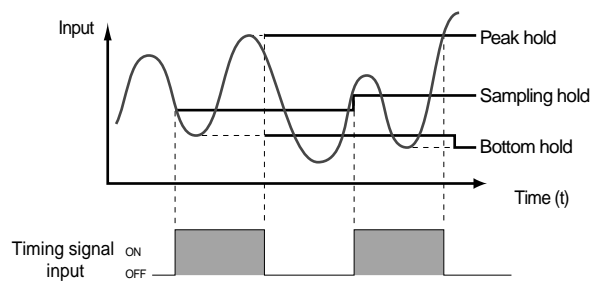

- **Modular Construction for Adapting to Various Specifications**



Clear

- **Red-Green Display Allows Easy Recognition of Judgment Results**

The measurement value display can be set to switch between red and green in accordance with the status of comparative outputs. This means that the status can be ascertained at a distance.

- **Position Meter Enables Easy Monitoring of Operating Status Trends**

The present value with respect to the measurement or display range (full scale) can be viewed on a bar display. This means that the operating status can be grasped intuitively, allowing easy judgement of levels and threshold values.

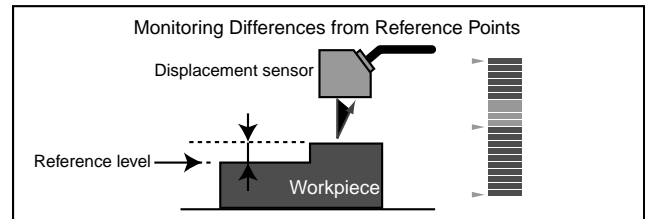
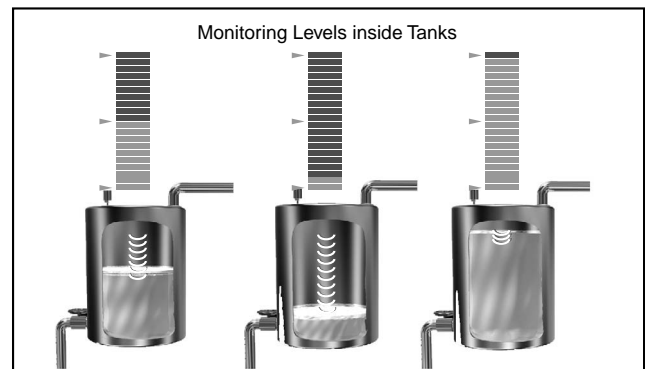
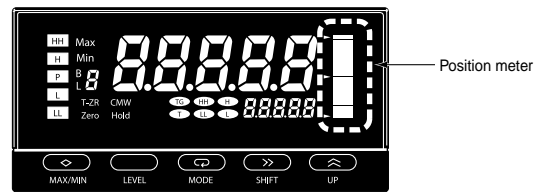

- **Equipped with SV Display for Reliable Setting**

Both the parameter name and value set for that parameter can be viewed at the same time in setting mode.

- **Short Body with Depth of Only 95 mm (from Behind the Front Panel)**

A short body of only 95 mm contributes to the development of slimmer and smaller control panels and installations.

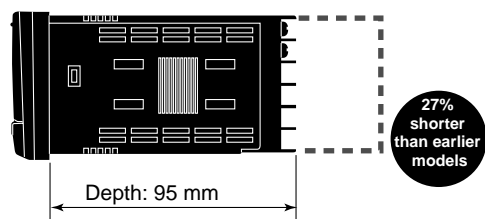

Linear Sensor Indicator K3HB-S

A Linear Sensor Indicator Capable of High-speed Response at 2,000 Times per Second

- Effective for high-speed measurement and discrimination with a sampling period of 0.5 ms and an output response time of 1 ms max.
- Allows OK/NG judgement using display that can be switched between green or red.
- Equipped with a position meter that represents measured amounts and relative positions.
- Zero calibration can be performed easily with the forced zero function.
- Short body with depth of only 95 mm (from behind the front panel).
- Recognized to U.S. and Canadian requirements under the component Recognition Program of UL.
- Conforms to CE marking.



Model Number Structure

■ Model Number Legend

Base Units and Optional Boards can be ordered individually or as sets.

Base Units

K3HB-S
1 5

- 1. Input Sensor Codes**
SD: DC voltage/current input
- 5. Supply Voltage**
100-240VAC: 100 to 240 VAC
24VAC/VDC: 24 VAC/VDC

Optional Board

- Sensor Power Supply/Output Boards

K33-
2

- Relay/Transistor Output Boards

K34-
3

- Event Input Boards

K35-
4

Base Units with Optional Boards

K3HB-S
1 2 3 4 5

- 2. Sensor Power Supply/Output Type Codes**
CPA: 12-VDC 80-mA model with PASS-output (PASS: SPDT)
A: 12-VDC 80-mA model
- 3. Relay/Transistor Output Type Codes**
C1: H/L models with relay outputs (H, L: SPDT)
C2: HH/H/L/LL models with relay outputs (HH, H, L, LL: SPST-NO)
T1: 5 comparative transistor outputs (NPN open collector)
T2: 5 comparative transistor outputs (PNP open collector)
- 4. Event Input Type Codes**
1: Models with terminal blocks (NPN open collector)
2: Models with terminal blocks (PNP open collector)
3: Models with connectors (NPN open collector)
4: Models with connectors (PNP open collector)

Ordering Information

■ DC Voltage/Current Input (for All Models)

(Each model has a multirange, thus corresponding to the following voltage and current ranges.)

Current measurement range	Voltage measurement range
0.000 to 20.000 mA or 4.000 to 20.000 mA	0.000 to 5.000 V or 1.000 to 5.000 V or -5.000 to 5.000 V or -10.000 to 10.000 V

■ Base Units

Model	Supply voltage	Part number	Applicable sensor power supply/output boards	Applicable relay/transistor output boards	Applicable event input boards
	100 to 240 VAC	K3HB-SSD 100-240VAC	K33-CPA K33-A	K34-C1 K34-C2 K34-T1 K34-T2	K35-1 K35-2 K35-3 K35-4
	24 VAC/VDC	K3HB-SSD 24VAC/VDC			

Specifications

■ Ratings

Power supply voltage	100 to 240 VAC (50/60 Hz)	24 VAC (50/60 Hz) or 24 VDC
Permissible power supply voltage range	85% to 110% of the rated power supply voltage	
Power consumption (with maximum load) (See note.)	18 VA max.	24 VAC: 11 VA max. 24 VDC: 7 W max.
Input signals	DC voltage/current (0 to 20 mA, 4 to 20 mA, 0 to 5 V, 1 to 5 V, ± 5 V, ± 10 V), 2 channels	
Measurement method	Sequential comparison system	
Sensor power supply	12 VDC $\pm 10\%$, 80 mA (only for models with sensor power supply)	
Event input	Timing input	NPN open collector or no-voltage contact signal (Refer to <i>Event Input Ratings</i> on page 7 for details.) PNP open collector
	Startup compensation timer input	
	Hold input	
	Reset input	
	Forced-zero input	
	Bank input	
Output (Depends on model.)	Relay contact output	H/L, 2 outputs, both SPDT 250 VAC/30 VDC, 5 A (resistive load), electrical life expectancy of 100,000 operations HH/H/L/LL, 4 outputs, all SPST-NO 250 VAC/30 VDC, 5 A (resistive load), electrical life expectancy of 100,000 operations PASS, 1 output, SPDT 250 VAC/30 VDC, 5 A (resistive load), electrical life expectancy of 100,000 operations
	Transistor output	HH/H/PASS/L/LL (NPN open collector; Maximum load voltage: 24 VDC; Maximum load current: 50 mA; Leakage current: 100 μ A max.) HH/H/PASS/L/LL (PNP open collector; Maximum load voltage: 24 VDC; Maximum load current: 50 mA; Leakage current: 100 μ A max.)
Display method	Negative LCD (backlit LED) display 7-segment digital display (PV character height: 14.2 mm (green/red); SV character height: 4.9 mm (green))	
Main functions	Scaling function, 2-input calculation function, measurement operation selection, averaging, high pass filter, forced-zero, zero-limit, output hysteresis, output OFF delay, output test, teaching, display value selection, display color selection, key protection, bank selection, display refresh period, maximum/minimum hold, reset	
Ambient operating temperature	-10 to 55 °C (with no icing or condensation)	
Ambient operating humidity	25% to 85%	
Storage temperature	-25 to 65 °C (with no icing or condensation)	
Altitude	2,000 m max.	
Accessories	Waterproof packing, 2 fixtures, terminal cover, unit stickers, operation manual	

Note: A control power supply capacity greater than the rated value is required when power is turned ON. Particular attention is required when using two or more DC power supply models. When power is turned ON or when the startup compensation timer operates, all outputs will turn OFF if the Unit is not performing measurement.

■ Characteristics

Sampling period	0.5 ms (1 input), 1.0 ms (2 inputs)	
Maximum number of display digits	5 digits (-19,999 to 99,999)	
Comparative output response time (transistor output)	1 input	ON to OFF: 1 ms max.; OFF to ON: 1.5 ms max.
	2 inputs	ON to OFF: 2 ms max.; OFF to ON: 2.5 ms max.
Insulation resistance	20 MΩ min. (at 500 VDC)	
Dielectric strength	2,300 VAC for 1 min between terminals and case	
Noise immunity	100 to 240-VAC models: ±1,500 V at power supply terminals in normal or common mode (waveform with 1-ns rising edge and pulse width of 1 μs/100 ns) 24-VAC/VDC models: ±1,500 V at power supply terminals in normal or common mode (waveform with 1-ns rising edge and pulse width of 1 μs/100 ns)	
Vibration resistance	Frequency: 10 to 55 Hz; Acceleration: 50 m/s ² ; 10 sweeps of 5 min each in X, Y, and Z directions	
Shock resistance	Transistor output models: 150m/s ² , 3 times each in 3 axes, 6 directions Contact output models: 100m/s ² , 3 times each in 3 axes, 6 directions	
Weight	Approx. 230 g (Base Unit only)	
Enclosure ratings	Front panel: Conforms to NEMA 4X for indoor use (equivalent to IP66) Rear case: IP20 Terminals: IP00 + finger protection (VDE0106/100)	
Memory protection	EEPROM (non-volatile memory); Number of rewrites: 100,000 times	
Installation environment	Overvoltage category II, pollution degree 2 (as per IEC61010-1)	
Safety standards	UL3121-1, CSA C22.2 No. 1010.1 (evaluated by UL) EN61010-1 (IEC61010-1): Pollution degree 2/overvoltage category 2 (evaluated by TÜV Product Service.) EN61326: 1997, A1: 1998, A2: 2001	
EMC	EMI: EN61326+A1 industrial applications Terminal interference wave voltage CISPR 11 Group 1, Class A: CISPR16-1/-2 Electromagnetic interference wave CISPR 11 Group 1, Class A: CISPR16-1/-2 EMS: EN61326+A1 industrial applications Electrostatic discharge (ESD) EN61000-4-2: 4 kV (contact), 8 kV (in air) Radiating radio-frequency electromagnetic field EN61000-4-3: 10 V/m 1 kHz sine wave amplitude modulation (80 MHz to 1 GHz) Burst EN61000-4-4: 2 kV (power line), 1 kV (I/O signal line) Surge EN61000-4-5: 1 kV with line (power line), 2 kV with ground (power line) Radio-frequency electric interference EN61000-4-6: 3 V (0.15 to 80 MHz) Momentary power interruptions from voltage dips EN61000-4-11: 0.5 cycle, 0°, 180°, 100% (rated voltage)	

■ Input Ranges (or Measurements Ranges and Accuracy)

Input specification	Input type	Measurement range	Indication range	Accuracy (at 23±5°C)	Input impedance	Maximum absolute rated input
DC current/voltage input	0 to 20 mA	0.000 to 20.000 mA	-2.000 to 22.000 mA	One input: ±0.1% FS ±1 digit max.	120 Ω max.	±31 mA
	4 to 20 mA	4.000 to 20.000 mA	2.000 to 22.000 mA			
	0 to 5 V	0.000 to 5.000 V	-0.500 to 5.500 V	Two inputs: ±0.2% FS ±1 digit max.	1 MΩ min.	±10 V
	1 to 5 V	1.000 to 5.000 V	0.500 to 5.500 V			
	±5 V	±5.000 V	±5.000 V			
	±10 V	±10.000 V	±11.000 V			

■ Event Input Ratings

Input type	S-TMR, HOLD, RESET, ZERO, BANK1, BANK2, BANK4	TIMING
Contact input	ON: 1 kΩ max. OFF: 100 kΩ min.	---
No-contact input	ON residual voltage: 2 V max. OFF leakage current: 0.1 mA max. Load current: 4 mA max. Maximum applied voltage: 30 VDC max.	ON residual voltage: 3 V max. OFF leakage current: 1.5 mA max. Load current: 17 mA max. Maximum applied voltage: 30 VDC max.

■ Output Ratings

Contact Output

Item	Resistive loads (250 VAC, cosφ=1; 30 VDC, L/R=0 ms)	Inductive loads (250 VAC, cosφ=0.4; 30 VDC, L/R=7 ms)
Rated load	250 VAC, 5 A 30 VDC, 5 A	250 VAC, 1 A 30 VDC, 1 A
Rated through current	5 A	
Mechanical life expectancy	5,000,000 operations	
Electrical life expectancy	100,000 operations	

Transistor Output

Maximum load voltage	24 VDC
Maximum load current	50 mA
Leakage current	100 μA max.

Connections

Terminal Arrangement

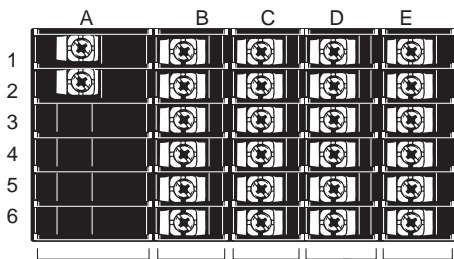

Note: Insulation is used between signal input, event input, output, and power supply terminals.

A Operating Power Supply

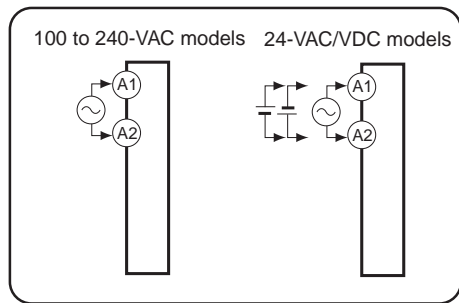

B Sensor Power Supply/Output

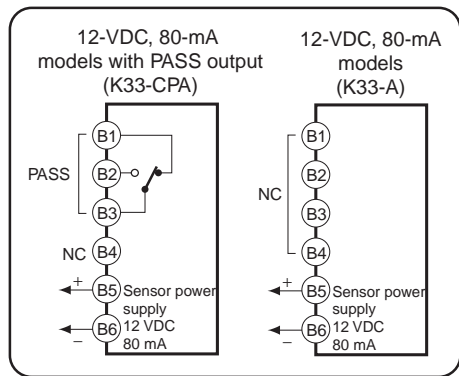

C Relay/Transistor Outputs

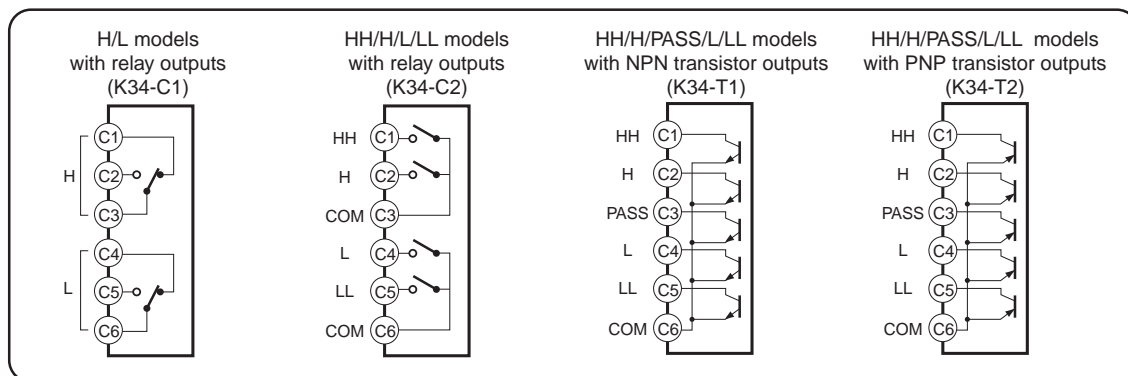

E Analog Input

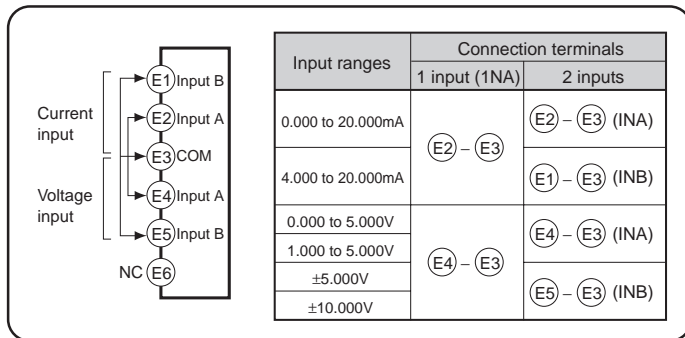

D Event Input

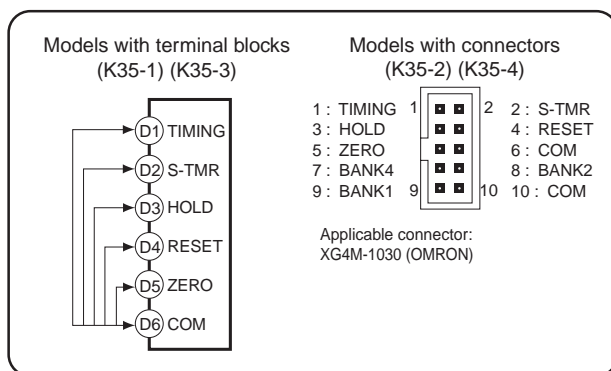

Output Circuits

Internal Block Diagram

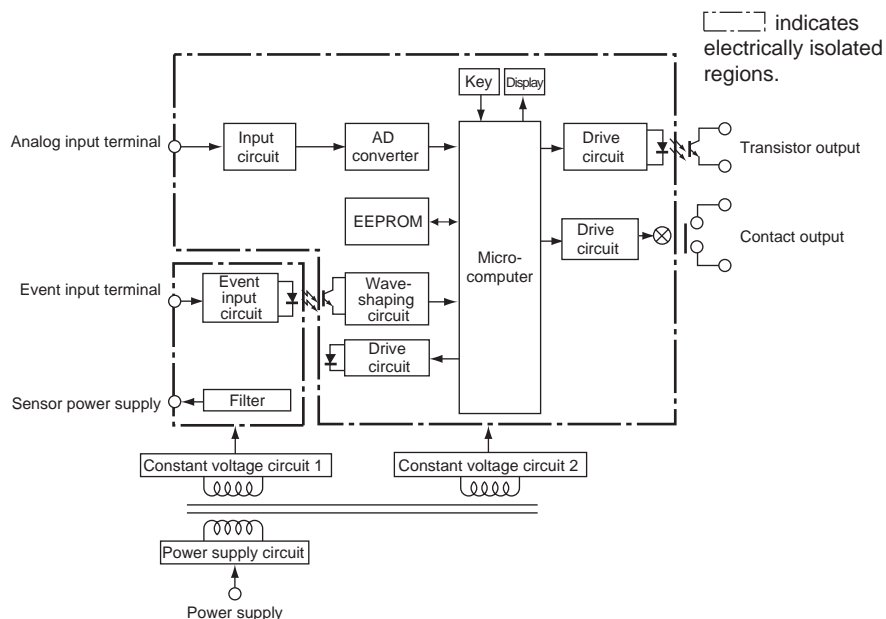

I/O Circuit Diagrams

Analog Inputs (DC Voltage and Current)

- Use terminal E3 as the analog common.

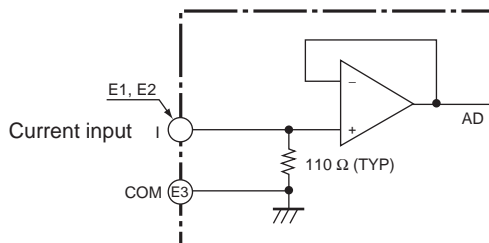
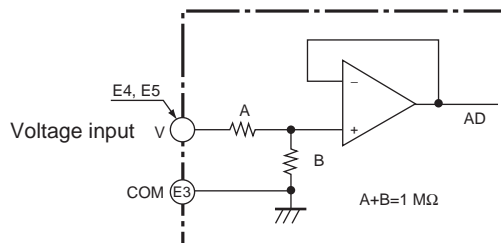

Event Inputs

- Use terminal D6 as the common terminal.
- Use open collector or no-voltage contacts for event input.

Note: PNP types are also available.

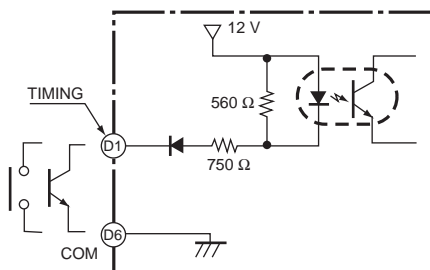
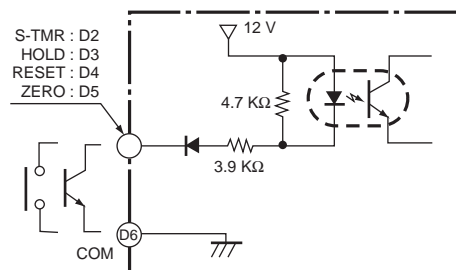

Comparative Outputs

Contact Outputs

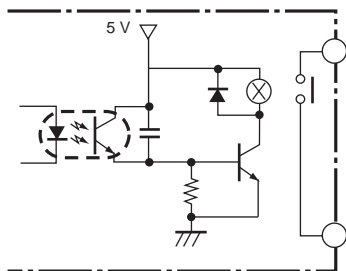

Transistor Outputs (NPN Open Collector)

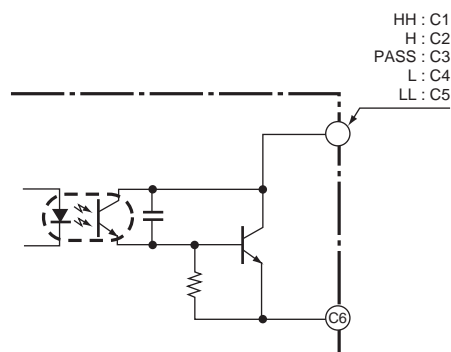

Operation

Operations in RUN Level

Displaying the Maximum and Minimum Values

When the measurement value is displayed, the maximum and minimum values can be displayed by pressing the MAX/MIN Key.

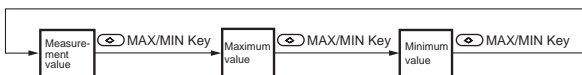

The maximum and minimum values can be reset by holding down the MAX/MIN Key for 1 s min.

Displaying and Changing Comparative Set Values

- When the measurement value, maximum value, or minimum value is displayed, pressing the MODE Key will display comparative set values HH, H, L, and LL (in order) in the SV display.

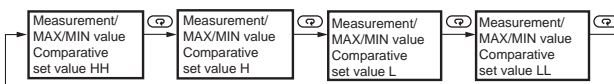

- To change comparative set values, select the comparative set value to be changed with the MODE Key and press the SHIFT Key. The SV display will flash. Change the comparative set value with the SHIFT and UP Keys. (This is possible only if setting change protect is OFF.)

Setting and Releasing Forced-zero

Setting Forced-zero

The forced-zero function allows reference values to be set as 0.

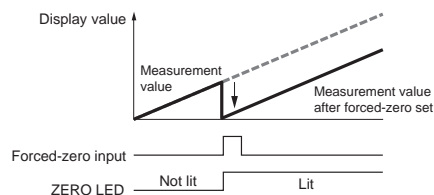

- When the measurement value is displayed, pressing the UP Key will shift the displayed value to 0. After this, measurement will be performed.
- If forced-zero is prohibited in the protect level, it cannot be set using the UP Key. The default setting for forced-zero prohibition is OFF.
- The zero status indicator will be lit when forced-zero is set.
- Measurement values obtained when forced-zero is set (shifted values) will be saved if the power is reset.

Releasing Forced-zero

- Forced-zero can be released by holding down the UP Key for 1 s min. The zero status indicator will turn OFF.

Initial Setting Flowchart

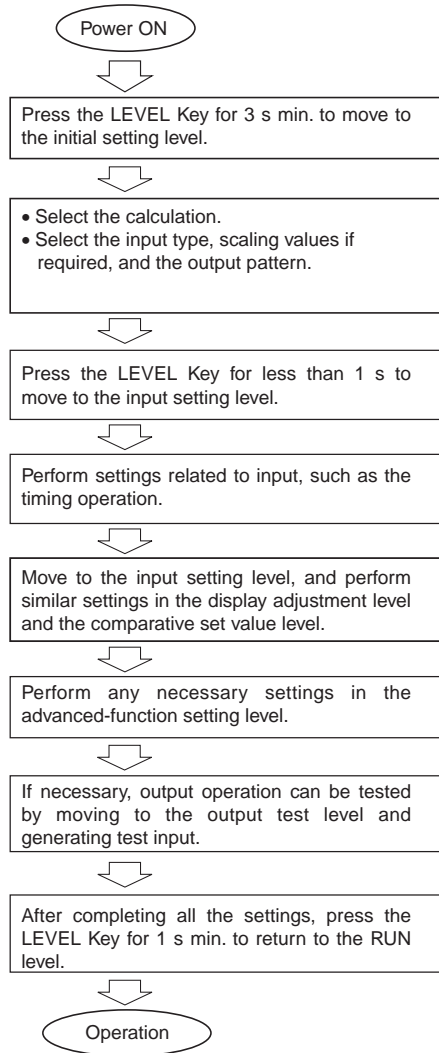

Moving between Levels

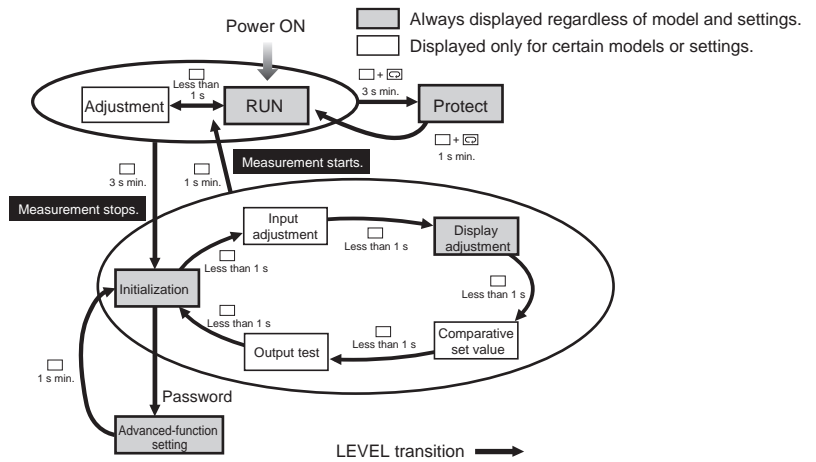

Protect Level

Press the LEVEL and MODE Keys Simultaneously in RUN level for at least 1 second. The PV display will start to flash. Press the same keys for at least 2 seconds to move to protect level.

Press the LEVEL and MODE Keys simultaneously for at least 1 second to return to RUN level.

Adjustment Level

Press the LEVEL Key in RUN level once (less than 1 second). The level will change to adjustment level when the key is released. Use the same operation to return from adjustment level to RUN level.

Initial Setting Level

Press the LEVEL Key in RUN or adjustment level for at least 1 second. The PV display will start to flash. Press the LEVEL Key for at least 2 seconds to move to the initial setting level.

Press the LEVEL Key for at least 1 second to return to the RUN level from the initial setting level.

Input Adjustment Level, Display Adjustment Level, Comparative Set Value Level, Output Test Level

First, move to initial setting level. Press the LEVEL Key in initial setting level (less than 1 second) each time to move to the next level. Moving to the next level from the output test level returns you to the initial setting level.

Setting Menus and Parameters

Parameter Display

- : Always displayed regardless of model or settings.
- : Displayed only for certain models or settings.

To return to the first parameter in the RUN or initial setting level from any display (except for the protect level), press the LEVEL Key for at least 1 second.

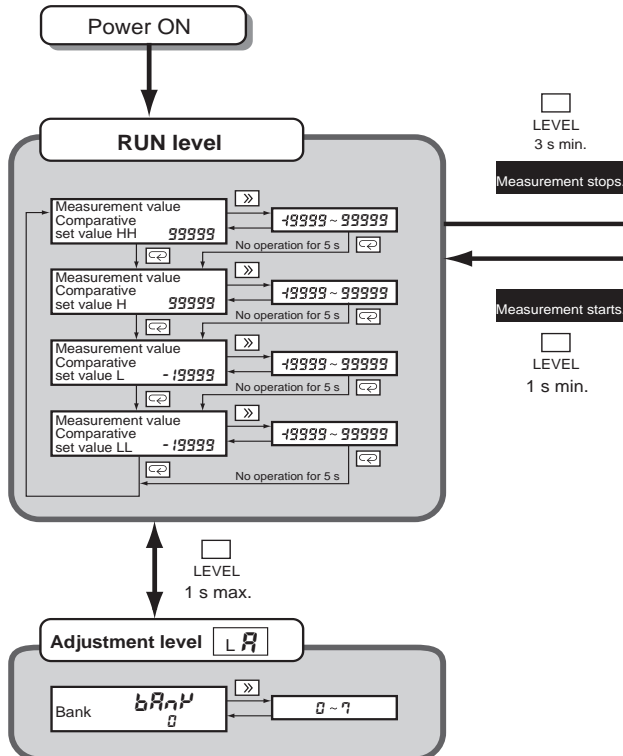

* Displayed when bank selection (bANP- \bar{C}) is not set to σFF .

Changing Set Values

Press the SHIFT Key when a parameter is displayed. The set value will flash. Change the set value and, press the MODE Key to register the new value. The next parameter will be displayed.

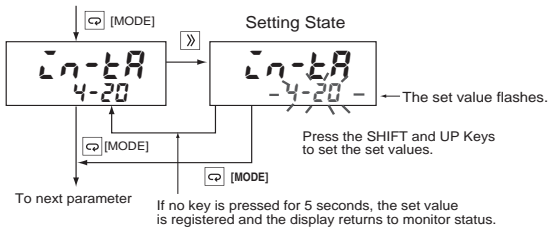

Initial setting level (LD)

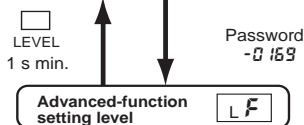
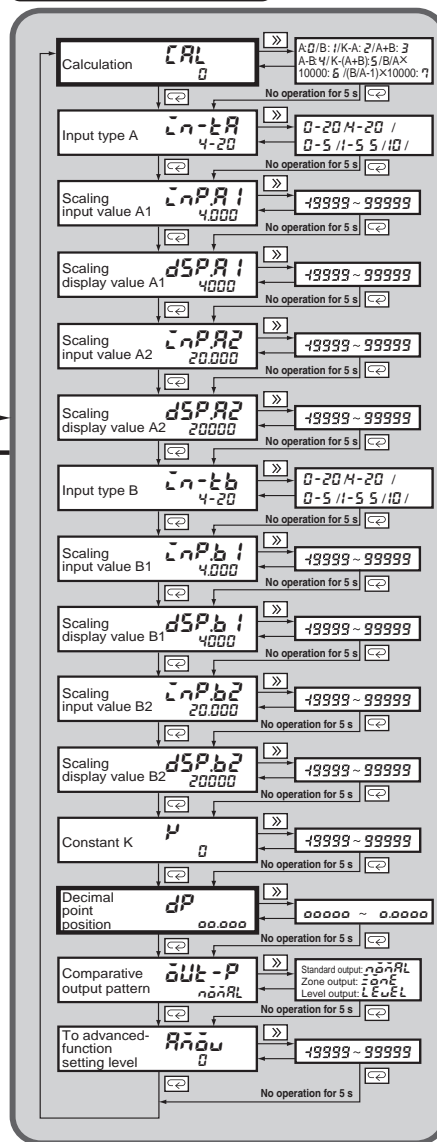

Output test level (LT)

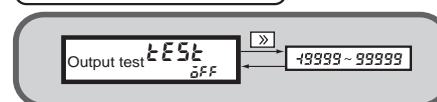

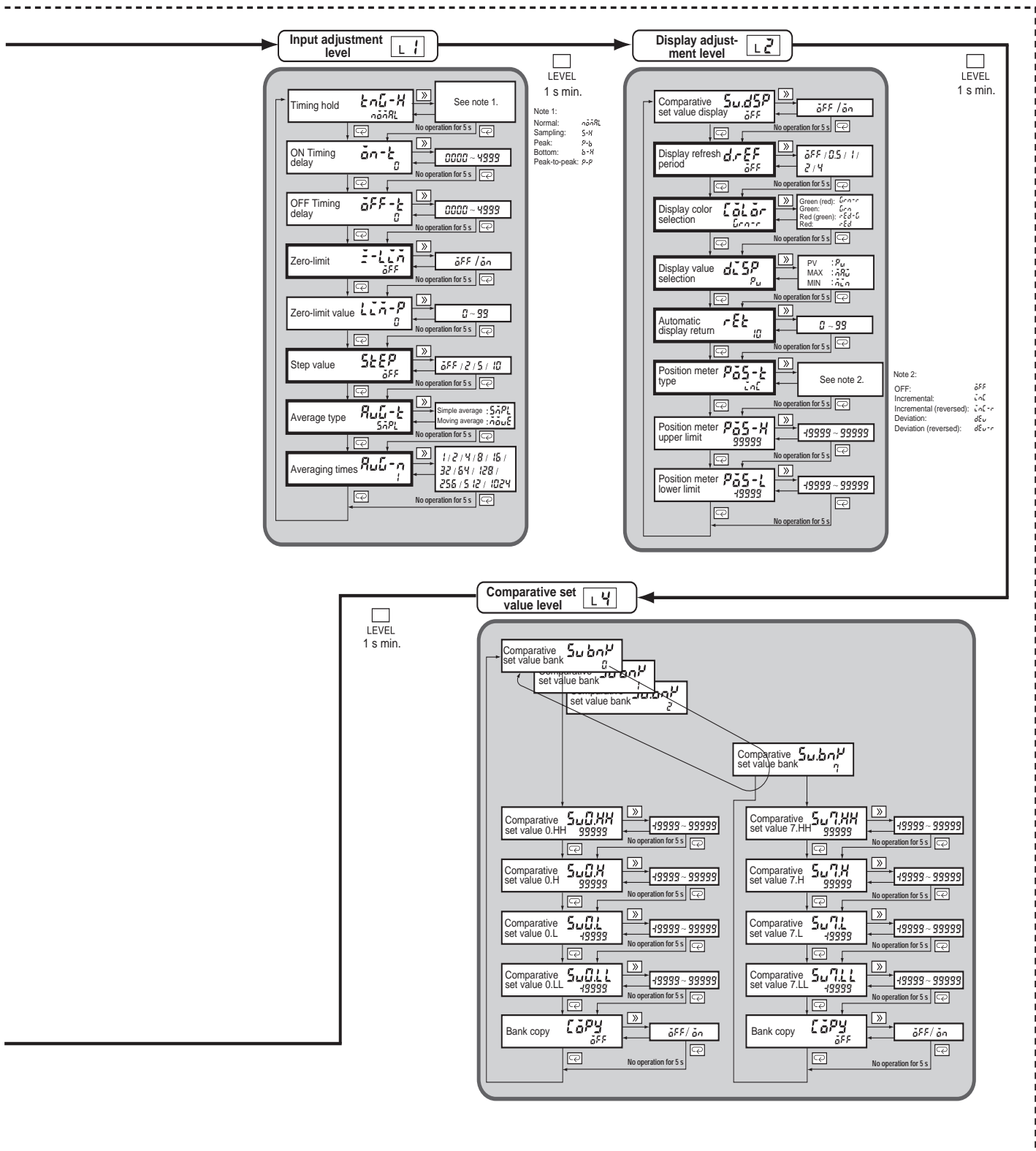

Initializing Settings

All settings can be initialized using the following parameter.

Parameter	Set value	Meaning
L̄n̄L̄t	ōFF	---
	ōn	Initialize settings

Use this function when, for example, redoing all settings starting from the delivery state.

Note: This operation will return all settings to their default values. The present settings will be lost. Before performing this operation, it is recommended that a record is made of the present settings.

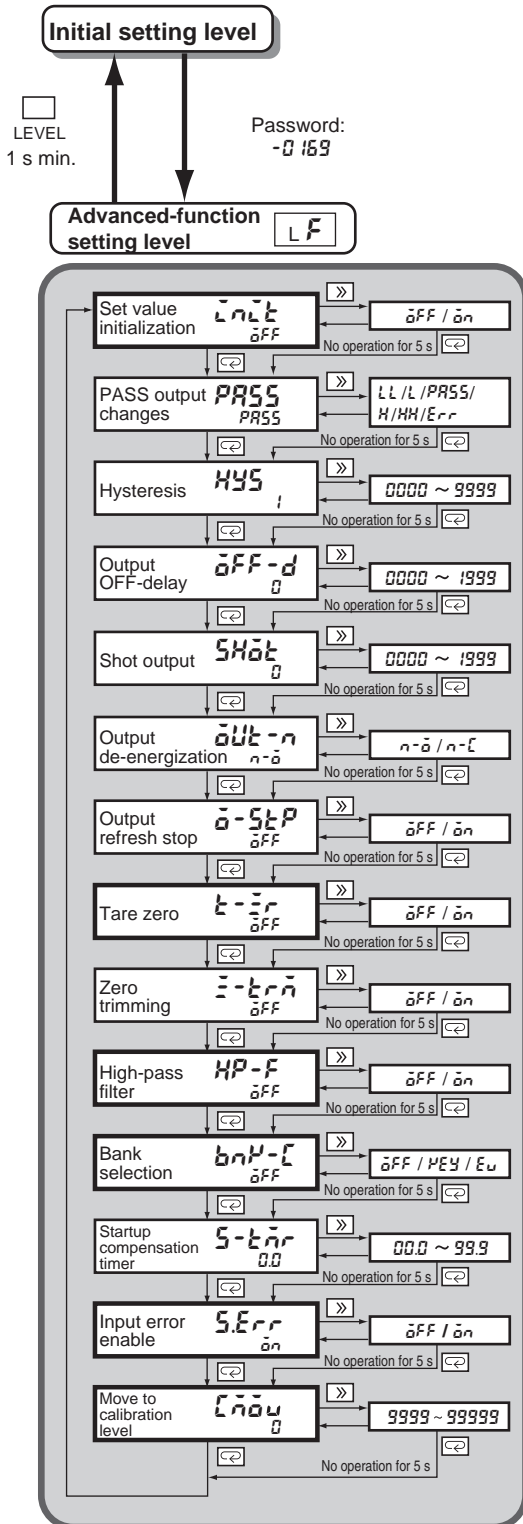

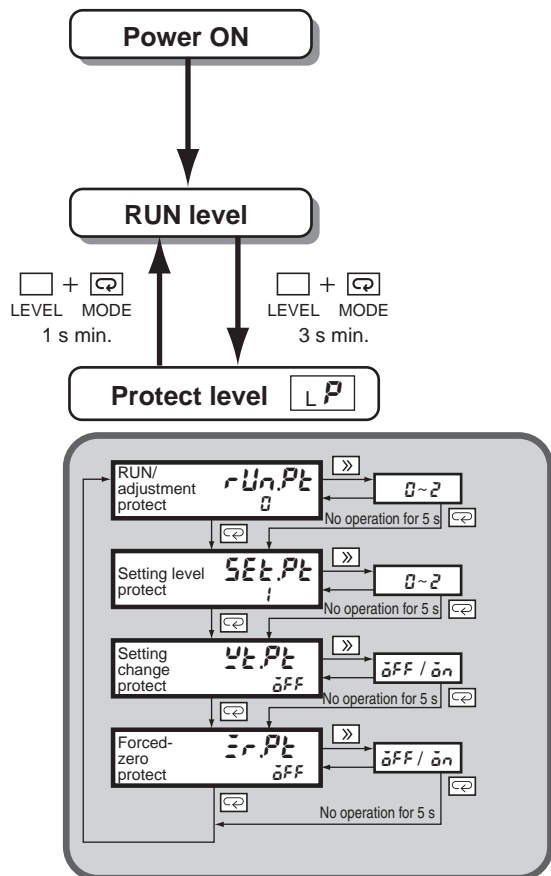

The "key protect" function limits level and parameter changes using key operations. There are 4 kinds of key protection. The parameters, settings, and details of each kind of protection are outlined below.

○ : Enabled, × : Prohibited

RUN/Adjustment Protect

(Limits key operations in RUN level and movement to adjustment level.)

Parameter	Set value	Restriction details		
		RUN level		Move to the adjustment level
		Present value display	Comparative set value change	
RUN/ad- justment protect <i>rUn.Pt</i>	0	○	○	○
	1	○	○	×
	2	○	×	×

Setting Level Protect

Parameter	Set value	Restriction details	
		Move to initialization, input adjustment display, adjustment, comparative set values, and output test levels	Move to the advanced function setting level
Setting level protect <i>SEt.Pt</i>	0	○	○
	1	○	×
	2	×	×

Setting Change Protect

(Disables changing settings with key operations.)

Parameter	Set value	Restriction details
Setting change protect <i>Ch.Pt</i>	OFF	Setting change using key operations: Enabled
	ON	Setting change using key operations: Prohibited

Note: All protect level parameters and movement to the advanced-function setting level and calibration level can be changed.

Forced-zero Protection

(Limits key-operated execution and clearing of forced-zero and tare zero.)

Parameter	Set value	Restriction details
Zero protect <i>Zr.Pt</i>	OFF	Forced-zero using key operations and tare zero execution/clear: Enabled
	ON	Forced-zero using key operations and tare zero execution/clear: Prohibited

■ Error Displays

PV display	SV display	Description of error	Countermeasure
<i>Unit</i> (UNIT)	<i>Err</i> (ERR)	An unexpected Unit was detected.	Check the Unit's model number and mount it in the correct position.
<i>Unit</i> (UNIT)	<i>CHG</i> (CHG)	Displayed the first time the power is turned ON after mounting a new Unit or changing the position of a Unit.	Press the LEVEL Key for at least 3 s to register the new Unit configuration.
<i>dCSP</i> (DISP)	<i>Err</i> (ERR)	Display error	Repair is necessary. Consult your OMRON representative.
<i>545</i> (SYS)	<i>Err</i> (ERR)	Internal memory error	
<i>EEP</i> (EEP)	<i>Err</i> (ERR)	Error in non-volatile memory	Press the LEVEL Key in this state for at least 3 s to return to the factory settings. (See note 1.)
<i>R.Err</i> (A.ERR) or <i>b.Err</i> (B.ERR)	Normal operation	Input error (See note 2.)	Set the input within the possible measurement range.
<i>99999</i> or <i>-19999</i> (flashing)		The input value is out of range or the measurement value after scaling is either greater than 99,999 or less than -19,999.	Set the input within the displayable range.

Note: 1. The parameters will be initialized. If the problem still persists after performing initialization, repair is necessary.

2. If there is an error in input A only, or if there is an error in both inputs A and B, *R.Err* is displayed, and if there is an error in input B only, *b.Err* is displayed.

Nomenclature

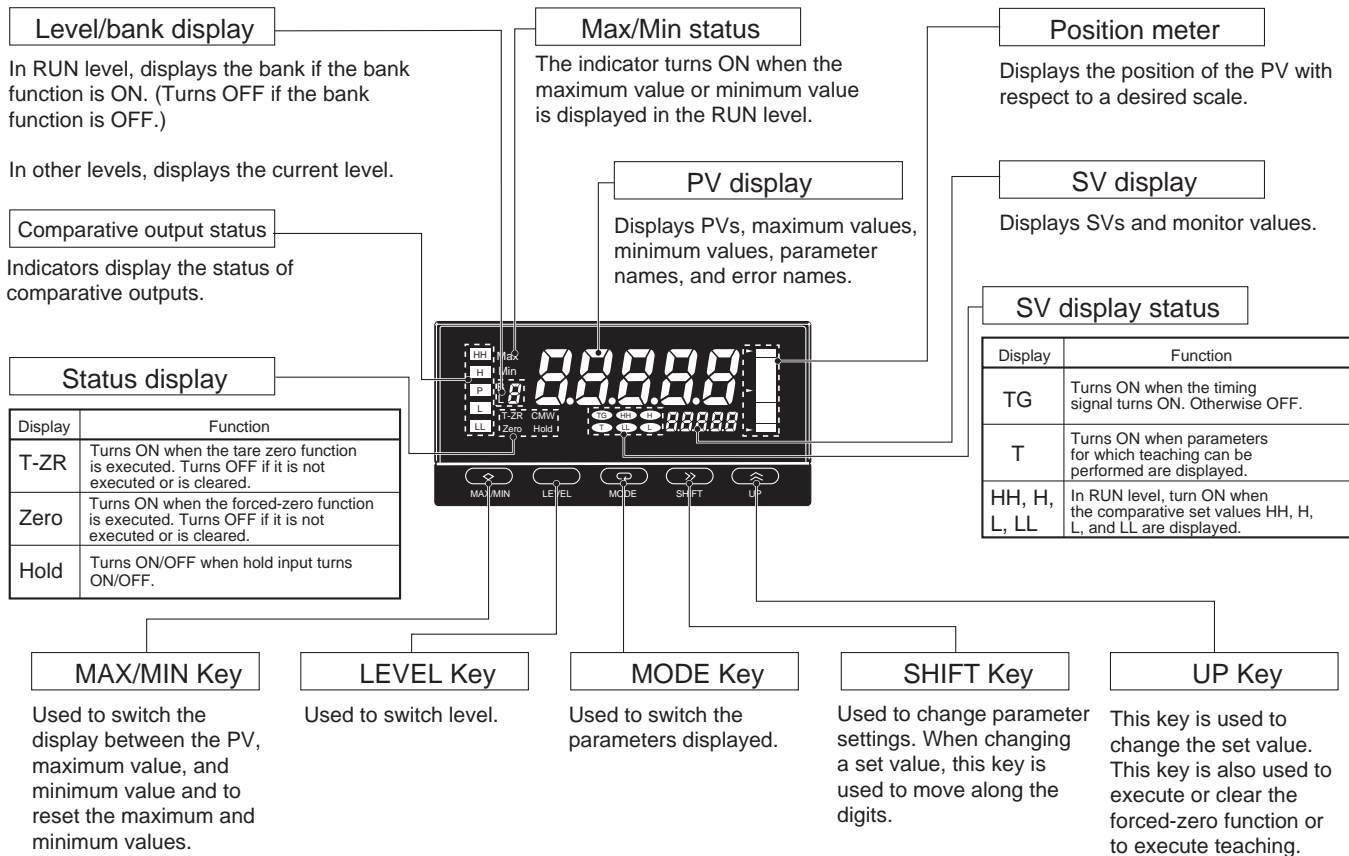

Engineering Data

Power Supply Derating Curve for Sensor

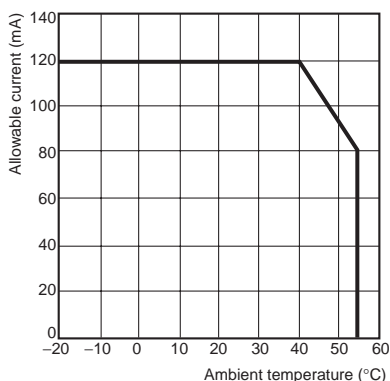

Note: The value for standard mounting. Note that the derating curve differs depending on the mounting.

Dimensions

Note: All units are in millimeters unless otherwise indicated.

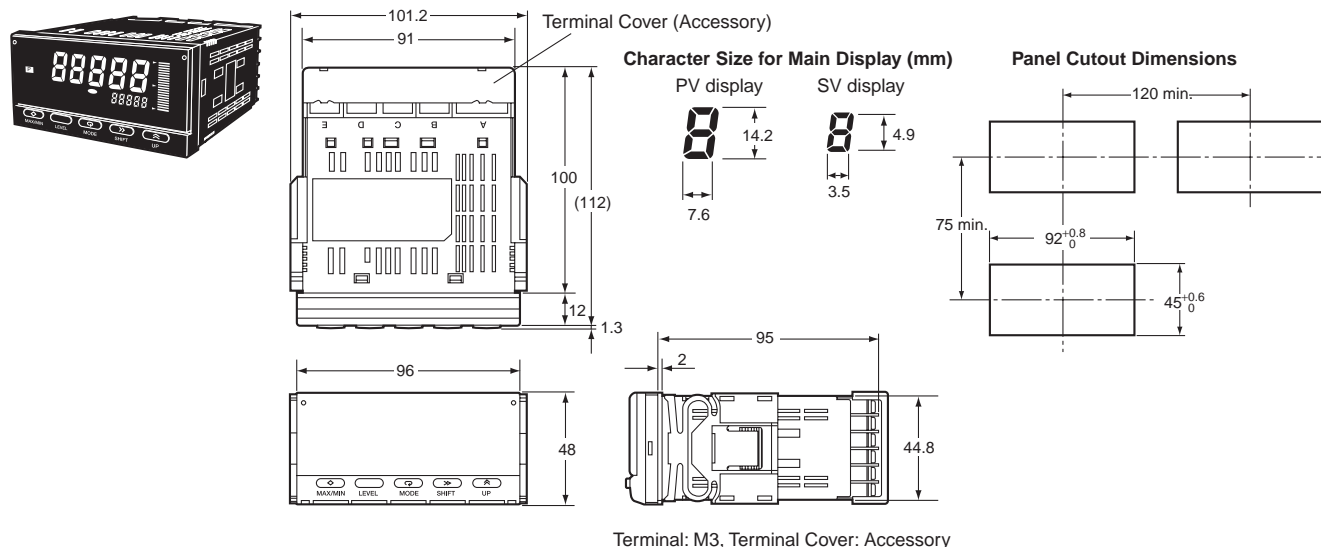

Application Examples

Height Measurement/Discrimination of Objects

The following operations are possible with K3HB-S:

- With a synchronous sensor, the sampling hold parameter makes it possible to display the height of an object and hold its value.
- The eight switchable banks make it possible for the K3HB-S to measure different kinds of objects smoothly.
- With the forced zero function, zero calibration can be done with ease.

K3HB-S Setting Details RUN Level

Parameter	Characters	Set value	Remarks
Comparative set value HH	(See note.)	3.00	Example of monitoring in two stages, at the ±2 mm and ±3 mm from the reference.
Comparative set value H	(See note.)	2.00	
Comparative set value L	(See note.)	-2.00	
Comparative set value LL	(See note.)	-3.00	

Note: Check on the status display.

Initial Setting Level (L1)

Parameter	Characters	Set value	Remarks
Calculation	CPL	0	
Input type A	Cn-tA	4-20	
Scaling input value A1	Cn.P.R.1	4.000	
Scaling display value A1	dSP.R.1	-4.00	
Scaling input value A2	Cn.P.R.2	20.000	
Scaling display value A2	dSP.R.2	4.00	
Decimal point position	dP	000.00	

Input Adjustment Level (L2)

Parameter	Characters	Set value	Remarks
Timing hold	tHG-H	5-H	Sampling hold

Display Adjustment Level (L3)

Parameter	Characters	Set value	Remarks
Display value selection	dLSP	Pv	Present value
Position meter type	PoS-t	dEv	Deviation display
Position meter upper limit	PoS-H	4.00	Full-scale ±4 mm
Position meter lower limit	PoS-L	-4.00	

Note: Only the parameters required for settings are displayed in the initial setting, input adjustment, and display adjustment levels.

Checking Dimensions after Press-fitting

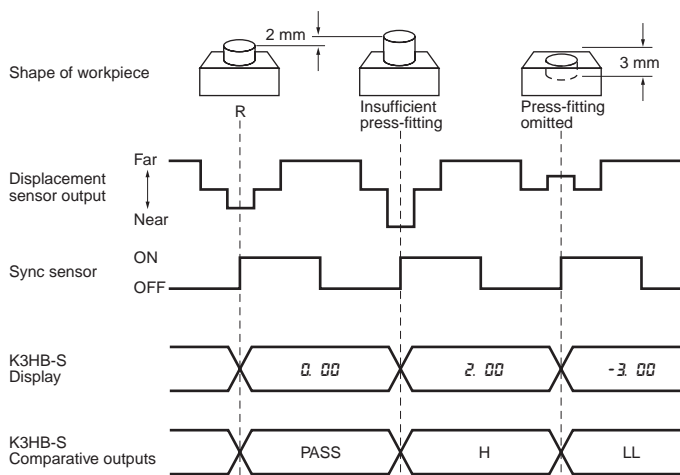
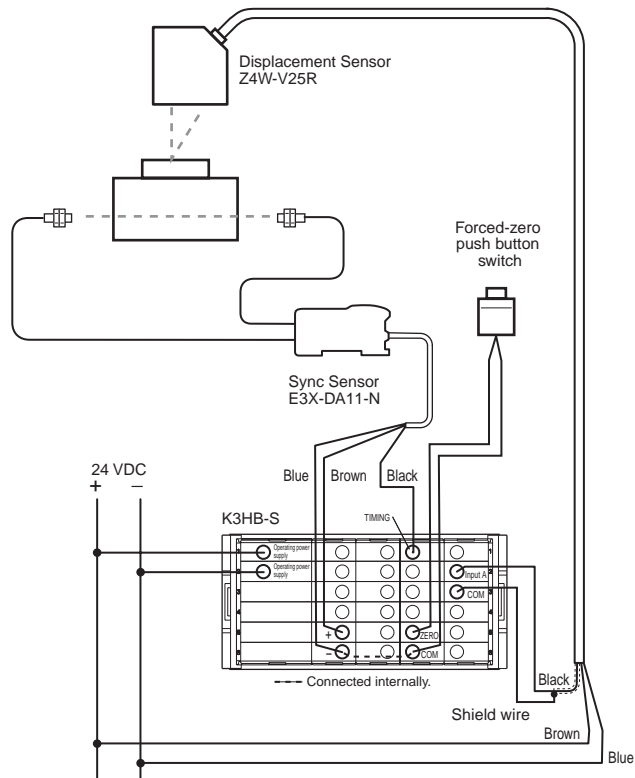
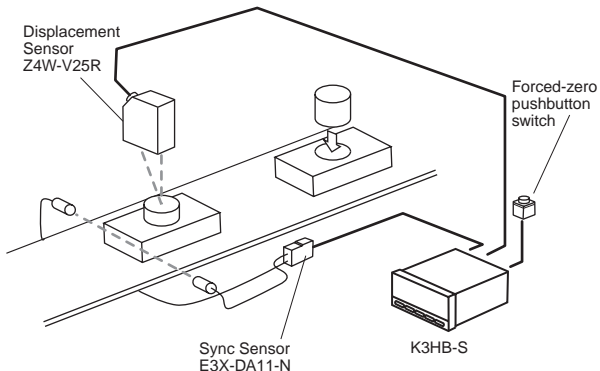

Measurement of Disc Eccentricity

The following operations are possible with K3HB-S:

- The peak-to-peak hold function can be used for simple eccentricity measurement by measuring the difference between the maximum and minimum values for linear sensor signals that change continuously.
- Measurements are taken while the timing input (the pushbutton switch in the following diagram) is ON and the last result is held when it is OFF.
- Applications such as measuring shaft eccentricity are possible. (Similar applications are possible for non-metallic objects using an ultrasonic displacement sensor.)

K3HB-S Setting Details Initial Setting Level (L0)

Parameter	Characters	Set value	Remarks
Calculation	\overline{CRL}	0	A
Input type A	$\overline{Cn-ER}$	4-20	E2CA Output (mA)
Scaling input value A1	$\overline{Cn.P.R1}$	4.000	
Scaling display value A1	$dSP.R1$	0.40	
Scaling input value A2	$\overline{Cn.P.R2}$	20.000	
Scaling display value A2	$dSP.R2$	2.00	
Decimal point position	dP	000.00	

Input Adjustment Level (L I)

Parameter	Characters	Set value	Remarks
Timing hold	$\bar{E} \bar{N} \bar{G} - H$	$P - P$	Peak-to-peak hold

Note: Only the parameters required for settings are displayed in the initial setting and input adjustment levels.

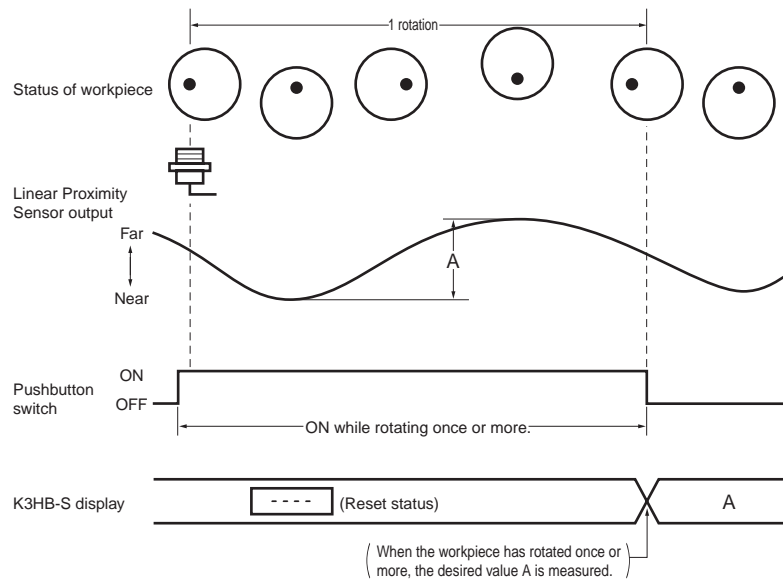
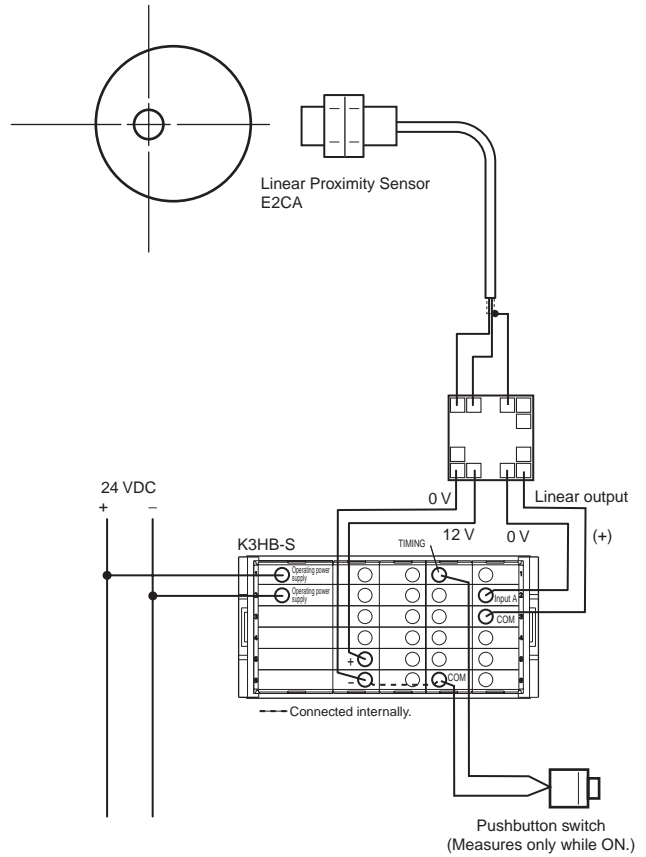
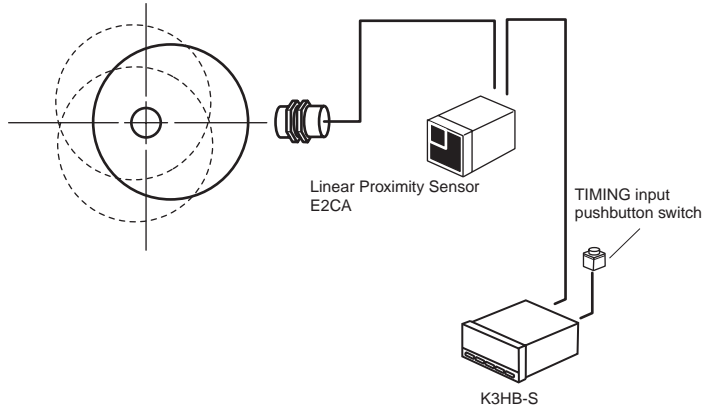

Measurement of Panel Thickness

The following operations are possible with the K3HB-S:

- Calculation mode $K-(A+B)$ can be used to convert panel thickness to actual size and measure it from the outputs of two displacement sensors.
- The forced-zero function can be used for one-touch deviation measurement from a reference panel thickness.

K3HB-S Setting Details RUN Level

Parameter	Characters	Set value	Remarks
Comparative set value H	(See note.)	20.50	Monitoring a difference of ± 0.5 mm for a reference panel thickness of 20 mm
Comparative set value L	(See note.)	19.50	

Note: Check on the status display.

Initial Setting Level (L 0)

Parameter	Characters	Set value	Remarks	
Calculation	$\overline{E}RL$	0	$K-(A+B)$	
Input type A	$\overline{C}n-tA$	4-20	<p>Z4W-V25R Output (mA)</p> <p>Displacement (mm)</p>	
Scaling input value A1	$\overline{C}nP.A1$	4.000		
Scaling display value A1	$dSP.A1$	21.00		
Scaling input value A2	$\overline{C}nP.A2$	20.000		
Scaling display value A2	$dSP.A2$	29.00		
Input type B	$\overline{C}n-tb$	4-20		
Scaling input value B1	$\overline{C}nP.b1$	4.000		
Scaling display value B1	$dSP.b1$	21.00		
Scaling input value B2	$\overline{C}nP.b2$	20.000		
Scaling display value B2	$dSP.b2$	29.00		
Constant K	μ	7000		Reference panel thickness 20 mm + sensor displacement 25 mm x 2
Decimal point position	dP	000.00		

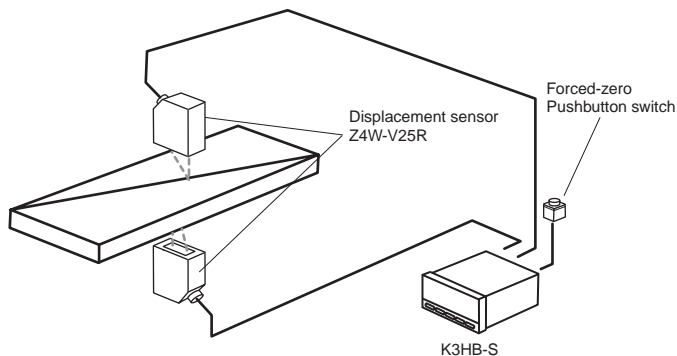

Input Adjustment Level (L 1)

Parameter	Characters	Set value	Remarks
Timing hold	$\overline{E}nG-H$	no nRL	Normal

Note: Only the parameters required for settings are displayed in the initial setting and input adjustment levels.

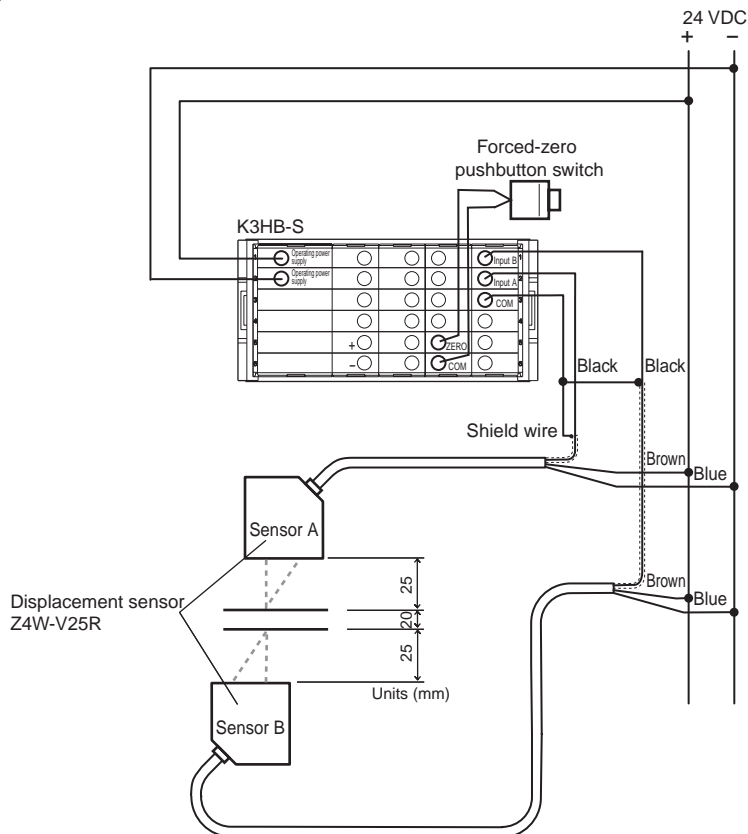

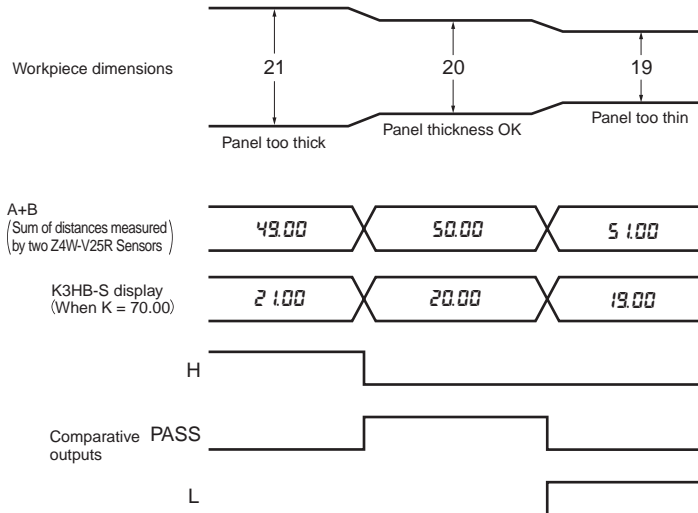

Measurement of Steps

The following operations are possible with the K3HB-S:

- Calculation mode A–B can be used to measure steps using two displacement sensors.
- The forced-zero function can be used to easily adjust the reference step dimension to the actual object.
- The effects of carrier line movement can be eliminated using a normal dimensions check to measure the dimensions between the workpiece surface and the carrier line surface.

K3HB-S Setting Details RUN Level

Parameter	Characters	Set value	Remarks
Comparative set value H	(See note.)	2.50	Monitoring a difference of ± 0.5 mm for a reference step of 2 mm
Comparative set value L	(See note.)	1.50	

Note: Check on the status display.

Initial Setting Level (L0)

Parameter	Characters	Set value	Remarks
Calculation	CAL	0	A–B
Input type A	cn-tr	4-20	<p>Z4W-V25R Output (mA)</p> <p>Displacement (mm)</p>
Scaling input value A1	cnP.R1	4.000	
Scaling display value A1	dSP.R1	21.00	
Scaling input value A2	cnP.R2	20.000	
Scaling display value A2	dSP.R2	29.00	
Input type B	cn-tb	4-20	
Scaling input value B1	cnP.b1	4.000	
Scaling display value B1	dSP.b1	21.00	
Scaling input value B2	cnP.b2	20.000	
Scaling display value B2	dSP.b2	29.00	
Decimal point position	dP	000.00	

Input Adjustment Level (L1)

Parameter	Characters	Set value	Remarks
Timing hold	LnG-H	5-H	Sampling hold

Note: Only the parameters required for settings are displayed in the initial setting and input adjustment levels.

Checking Molded Parts Dimensions

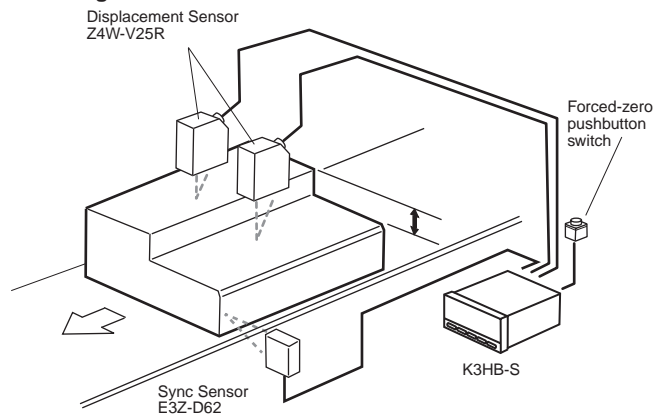

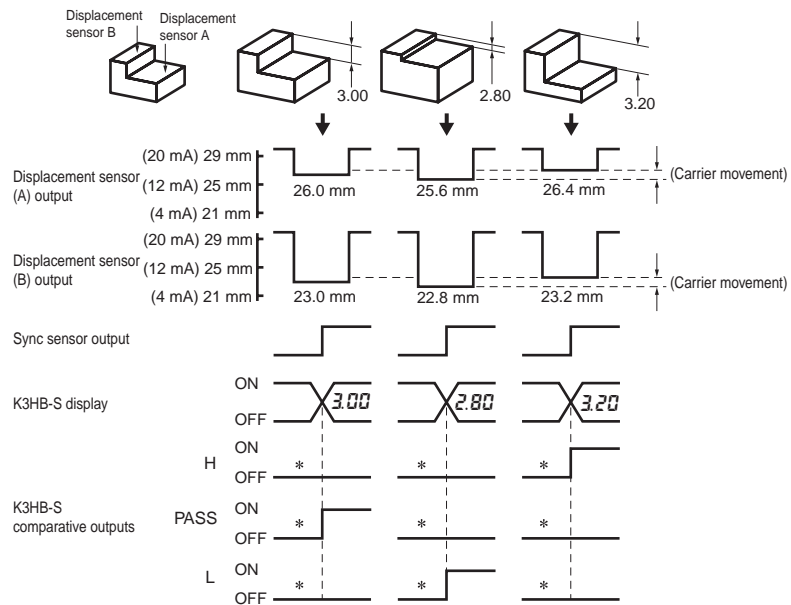
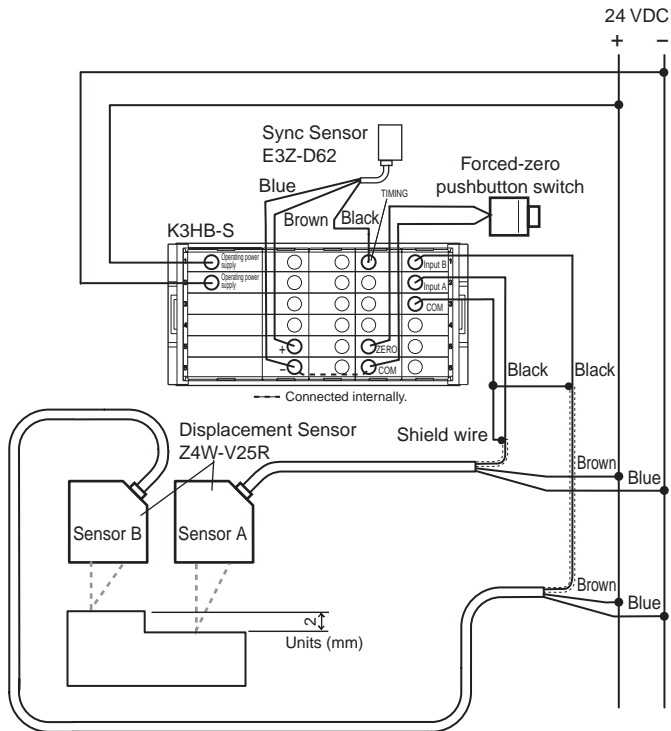

* The previous judgement result is held until the Sync Sensor turns ON. (All outputs turn OFF when RESET input is received.)

Operating Procedures

■ Main Functions

Measurement

Input Calculation

- The K3HB-S has two input circuits. The input ranges for these circuits can be set independently. For example, one can be set to 4 to 20 mA and the other can be set to 1 to 5 V.

- In addition to calculations such as K (constant)–A (input for one circuit), it is possible to perform calculations based on the inputs for both circuits, such as A+B and A–B, making it possible to perform thickness measurement and level-difference measurement using displacement and length-measuring sensors.

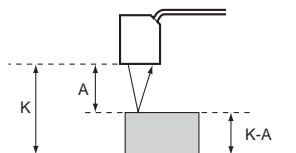

Timing Hold

Normal

- Continuously performs measurement and always outputs based on comparative results.

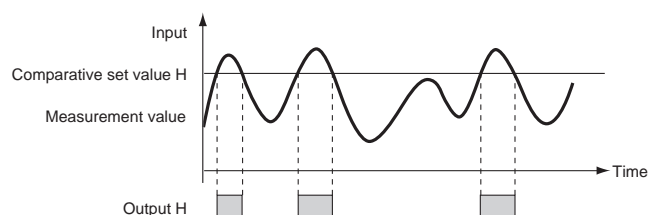

Peak Hold/Bottom Hold

- Measures the maximum (or minimum) value in a specified period.

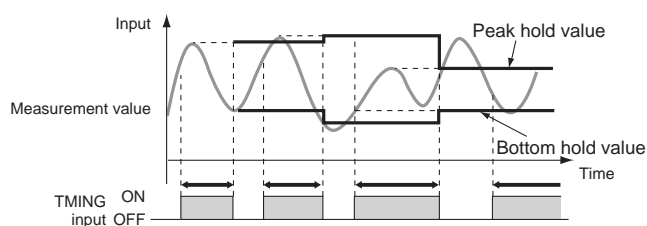

Sampling Hold

- Holds the measurement at the rising edge of the TIMING signal.

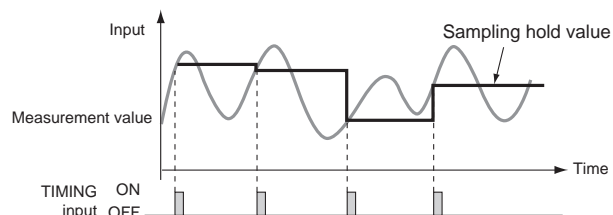

Peak-to-peak Hold

- Measures the difference between the maximum and minimum values in a specified period.

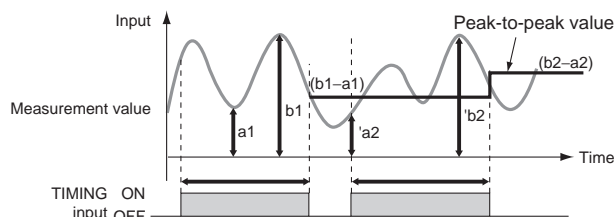

Scaling

The K3HB-S is equipped with a scaling function that converts input signals in any way required before displaying them. The values can be manipulated by shifting, inverting, or +/- reversing.

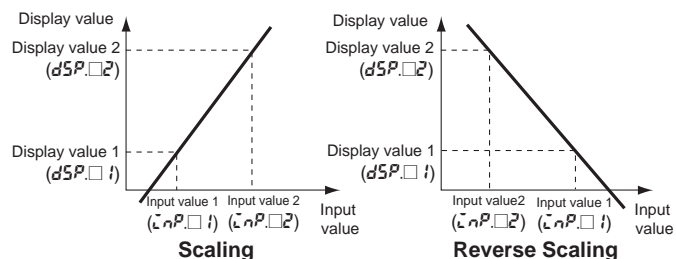

Average Processing

Averaging is a function that makes display and output smooth for input values with dramatic fluctuations, such as spike noise.

High-pass Filter

High-pass filter is a function that detects only sudden changes to input signals.

Teaching

Settings for scaling can be made using the present measurement values instead of inputting values with the SHIFT and UP Keys. This is a convenient function for making the settings while monitoring the operating status.

Input Compensation/Display

Forced-zero

The forced-zero function forces the present measurement value to zero. (Convenient for setting reference points or deducting tares for weight measurement.)

Tare Zero

The tare zero function shifts the present measurement value to 0 again using the forced-zero reference. Using the tare zero function, it is possible to weigh two or more compounds independently and then, by releasing the tare zero and forced-zero, measure the total combined weight.

Zero-trimming

The zero-trimming function performs compensation, based on OK (PASS) data, for mild fluctuations in input signals due to factors such as sensor temperature drift. (This function can be used with sampling hold, peak hold, or bottom hold.)

Zero-limit

The zero-limit function displays 0 for input values lower than a set value. It is enabled in normal mode only. (This function can be used, for example, to stop negative values being displayed or to eliminate flickering and minor inconsistencies near 0.)

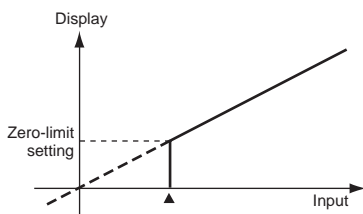

Output

Comparative Output Pattern

The output pattern for comparative outputs can be selected. In addition to high/low comparison with set values, output based on level changes is also possible. (Use the type of output pattern appropriate for the application.)

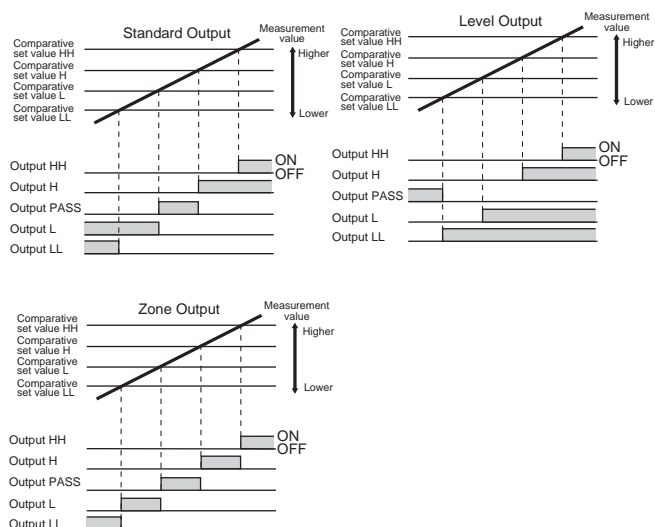

Output De-energization

The operation of comparative outputs with respect to the comparative result can be reversed.

Display Refresh Period

The display refresh period can be lengthened to reduce flickering and thereby make the display easier to read.

Display Color Selection

Values can be displayed in either red or green. With comparative output models, the display color can also be set to change according to the status of comparative outputs (e.g., green to red or red to green).

Example) Setting: Green

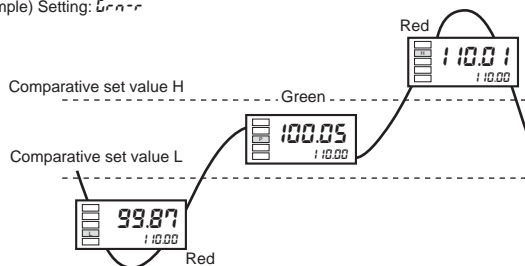

Display Value Selection

The present value, maximum value, or minimum value can be selected as the displayed value.

Step Value

It is possible to specify (i.e., restrict) the values that the smallest displayed digit can change by. For example, if the setting is 2, the smallest digit will only take the values 0, 2, 4, 6, or 8 and if the setting is 5, it will only take the values 0 or 5. If the setting is 10, it will only take the value of 0.

Hysteresis

This function prevents comparative output chattering near the comparative set values.

Example: Comparative Output Pattern (Standard Output)

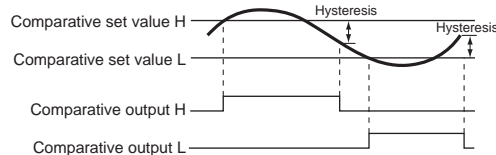

Startup Compensation Timer

Measurement can be stopped for a set time using external input.

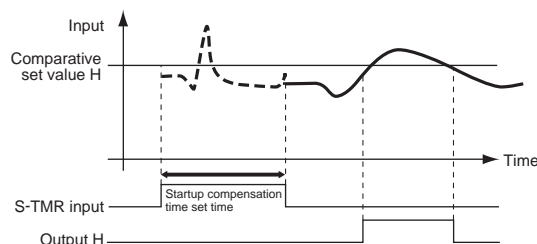

PASS Output Change

Comparative results other than PASS and error signals can be output from the PASS terminal.

Precautions

⚠ WARNING

Do not touch any of the terminals while the power is being supplied. Doing so may result in electric shock.

⚠ Caution

Do not disassemble the product or touch the internal components of the product while the power is being supplied. Doing so may result in electric shock.

⚠ Caution

Do not use the product in locations where flammable or explosive gases are present. Doing so may result in explosion.

⚠ Caution

Do not allow metal objects or wire cuttings to enter the product. Doing so may result in electric shock, fire, or malfunction.

⚠ Caution

Perform correct settings for the product according to the control application. Failure to do so may cause unexpected operation, resulting in damage to the product or injury.

⚠ Caution

Take safety measures, such as installing a separate monitoring system, to ensure safety even if the product fails. Product failure may prevent comparative outputs from being generated, resulting in serious accidents.

Observe the following precautions to ensure safety.

1. Maintain the power supply voltage within the range specified in the specifications.
2. Maintain the load within the ratings specified in the specifications.
3. Check each terminal for correct number and polarity before connecting it. Incorrect or reverse connections may damage or burn out internal components in the product.
4. Tighten the terminal screws securely. The recommended tightening torque is 0.43 to 0.58 N·m. Loose screws may cause product failure or malfunction.
5. Do not connect anything to unused terminals.
6. Provide a switch or circuit breaker so that operators can easily turn OFF the power supply when necessary. Also provide appropriate indications of such devices.
7. Do not attempt to disassemble, repair, or modify the product.
8. Do not use the product where flammable or combustible gases are present.
9. When mounting Optional Boards, do not touch electronic components or patterns on the PCB. Hold the PCB by the edges.

Application

General Precautions

1. Do not use the product in the following locations:
 - Locations subject to direct radiant heat from heating equipment.
 - Locations subject to exposure to water, oil, or chemicals.
 - Locations subject to direct sunlight.
 - Locations subject to dust or corrosive gases (particularly sulfuric gas or ammonia gas).
 - Locations subject to severe changes in temperature.
 - Locations subject to icing or condensation.
 - Locations subject to shock or vibration.
2. Do not block heat dissipation around the product, i.e., provide sufficient space for heat dissipation.

3. Ensure that the rated voltage is reached within two seconds after the power is turned ON.
4. Conduct aging for 15 minutes min. after power is turned ON for correct measurement.
5. Do not touch the slit sections or terminals while the power is being supplied to prevent the product from being affected by static electricity.
6. Do not lay heavy objects on the product during use or storage. Doing so may deform or deteriorate the product.
7. Do not use paint thinner for cleaning. Use commercially available alcohol.

Mounting

- Mount the product to a panel that is 1 to 8 mm thick.
- Install the product in a horizontal position.
- Use crimp terminals that match screw sizes.

Noise Prevention

- Install the product as far as possible from devices that generate strong, high-frequency fields (such as high-frequency welders or sewing machines) or surges.
- Install surge absorbers or noise filters on nearby devices that generate noise (particularly, motors, transformers, solenoids, magnet coils, and other devices that have a high inductance component).

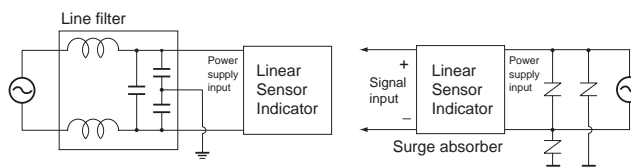

- To prevent inductive noise, separate the terminal block wiring for the product from high-voltage or high-current power lines. Do not route the wiring for the product in parallel with or tie it in a bundle with power lines. Take the following countermeasures against inductive noise in input lines.

Countermeasures for Inductive Noise on Input Lines

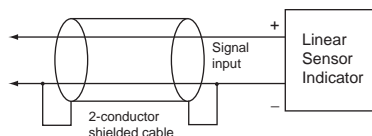

- When using a noise filter for the power supply, check for the voltage and current and install it as close as possible to the Linear Sensor Indicator.
- Do not install the product near radios, television sets, or wireless devices. Doing so may cause reception interference.

Increasing Service Life

- Do not use the product in locations where the temperature or humidity exceeds the ratings or where condensation may occur. When installing the product in a panel, be sure that the temperature around the product (not the temperature around the panel) does not exceed the ratings. The product service life depends on the ambient temperature. The higher the ambient temperature, the shorter the service life. To extend the product service life, lower the temperature inside the Linear Sensor Indicator.
- Use and store the product within the temperature and humidity ranges given in the specifications. When gang-mounting Linear Sensor Indicators or arranging them vertically, heat generated by the Linear Sensor Indicators will cause the internal temperature to rise, reducing the service life. In such cases, provide forced cooling methods, such as using a fan to circulate air around the Linear Sensor Indicators. Do not, however, allow only the terminals to be cooled. Doing so will increase measurement error.

- The life of the output relays is greatly affected by the switching capacity and switching conditions. Use these relays within their rated load and electrical life. The contacts may fuse or burn if they are used past their electrical life.

■ Wiring Precautions

- For terminal blocks, use the crimp terminals suitable for M3 screws.
- Tighten the terminal screws to the recommended tightening torque of approx. 0.5 N·m.
- To prevent inductive noise, separate the wiring for signal lines from that for power lines.

Wiring

- Use the crimp terminals suitable for M3 screws shown below.

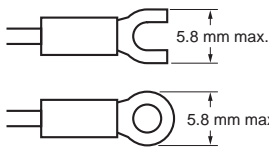

Unit Stickers

- There are no unit stickers attached to the Sensor at the time of delivery.
- Select the appropriate units from the unit sticker sheets provided.

V	A	V	A	%	J	Pa	Ω
s	/	N	m	W	°C	m ³	k
°F	g	min	mm	rpm			
VA	mV	mA	Hz				
m/min	OMRON						
OUT	OUT						

Note: When using for meters, such as weighing meters, use the units specified by regulations on weights and measures.

■ Mounting Method

1. Insert the K3HB-S into the mounting cutout in the panel.
2. Insert watertight packing around the Unit to make the mounting watertight.

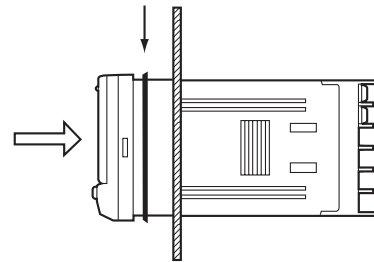

3. Insert the adapter into the grooves on the left and right sides of the rear case and push until it reaches the panel and is fixed in place.

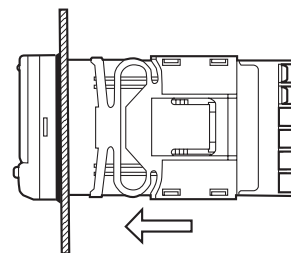

■ LCD Field of Vision

The K3HB-S is designed to have the best visibility at the angles shown in the following diagram.

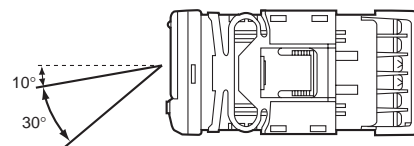

■ Waterproof Packing

The waterproof packing ensures a level of waterproofing that conforms to NEMA 4X. Depending on the operating environment, deterioration, contraction, or hardening may occur and replacement may be necessary. In this case, consult your OMRON representative.

Warranty and Limitations of Liability

■ WARRANTY

OMRON's exclusive warranty is that the products are free from defects in materials and workmanship for a period of one year (or other period if specified) from date of sale by OMRON.

OMRON MAKES NO WARRANTY OR REPRESENTATION, EXPRESS OR IMPLIED, REGARDING NON-INFRINGEMENT, MERCHANTABILITY, OR FITNESS FOR PARTICULAR PURPOSE OF THE PRODUCTS. ANY BUYER OR USER ACKNOWLEDGES THAT THE BUYER OR USER ALONE HAS DETERMINED THAT THE PRODUCTS WILL SUITABLY MEET THE REQUIREMENTS OF THEIR INTENDED USE. OMRON DISCLAIMS ALL OTHER WARRANTIES, EXPRESS OR IMPLIED.

■ LIMITATIONS OF LIABILITY

OMRON SHALL NOT BE RESPONSIBLE FOR SPECIAL, INDIRECT, OR CONSEQUENTIAL DAMAGES, LOSS OF PROFITS, OR COMMERCIAL LOSS IN ANY WAY CONNECTED WITH THE PRODUCTS, WHETHER SUCH CLAIM IS BASED ON CONTRACT, WARRANTY, NEGLIGENCE, OR STRICT LIABILITY.

In no event shall the responsibility of OMRON for any act exceed the individual price of the product on which liability is asserted.

IN NO EVENT SHALL OMRON BE RESPONSIBLE FOR WARRANTY, REPAIR, OR OTHER CLAIMS REGARDING THE PRODUCTS UNLESS OMRON'S ANALYSIS CONFIRMS THAT THE PRODUCTS WERE PROPERLY HANDLED, STORED, INSTALLED, AND MAINTAINED AND NOT SUBJECT TO CONTAMINATION, ABUSE, MISUSE, OR INAPPROPRIATE MODIFICATION OR REPAIR.

Application Considerations

■ SUITABILITY FOR USE

OMRON shall not be responsible for conformity with any standards, codes, or regulations that apply to the combination of products in the customer's application or use of the products.

At the customer's request, OMRON will provide applicable third party certification documents identifying ratings and limitations of use that apply to the products. This information by itself is not sufficient for a complete determination of the suitability of the products in combination with the end product, machine, system, or other application or use.

The following are some examples of applications for which particular attention must be given. This is not intended to be an exhaustive list of all possible uses of the products, nor is it intended to imply that the uses listed may be suitable for the products.

- Outdoor use, uses involving potential chemical contamination or electrical interference, or conditions or uses not described in this catalog.
- Nuclear energy control systems, combustion systems, railroad systems, aviation systems, medical equipment, amusement machines, vehicles, safety equipment, and installations subject to separate industry or government regulations.
- Systems, machines, and equipment that could present a risk to life or property.

Please know and observe all prohibitions of use applicable to the products.

NEVER USE THE PRODUCTS FOR AN APPLICATION INVOLVING SERIOUS RISK TO LIFE OR PROPERTY WITHOUT ENSURING THAT THE SYSTEM AS A WHOLE HAS BEEN DESIGNED TO ADDRESS THE RISKS, AND THAT THE OMRON PRODUCTS ARE PROPERLY RATED AND INSTALLED FOR THE INTENDED USE WITHIN THE OVERALL EQUIPMENT OR SYSTEM.

ALL DIMENSIONS SHOWN ARE IN MILLIMETERS.

To convert millimeters into inches, multiply by 0.03937. To convert grams into ounces, multiply by 0.03527.

Cat. No. N111-E1-01 **In the interest of product improvement, specifications are subject to change without notice.**

OMRON Corporation

Industrial Automation Company

Measuring and Control Division

Shiokoji Horikawa, Shimogyo-ku,
Kyoto, 600-8530 Japan
Tel: (81)75-344-7080/Fax: (81)75-344-7189

Regional Headquarters

OMRON EUROPE B.V.

Wegalaan 67-69, NL-2132 JD Hoofddorp
The Netherlands
Tel: (31)2356-81-300/Fax: (31)2356-81-388

OMRON ELECTRONICS LLC

1 East Commerce Drive, Schaumburg, IL 60173
U.S.A.
Tel: (1)847-843-7900/Fax: (1)847-843-8568

OMRON ASIA PACIFIC PTE. LTD.

83 Clemenceau Avenue,
#11-01, UE Square,
239920 Singapore
Tel: (65)6835-3011/Fax: (65)6835-2711

OMRON CHINA CO., LTD. BEIJING OFFICE

Room 1028, Office Building,
Beijing Capital Times Square,
No. 88 West Chang'an Road,
Beijing, 100031 China
Tel: (86)10-8391-3005/Fax: (86)10-8391-3688

Printed in Japan
0403-1M (0403) (B)