

Special-purpose Basic Switch DZ

DPDT Basic Switch for Two Independent Circuit Control

- Incorporates two completely independent built-in switches.
- Ideal for switching the circuits operating on two different voltages, and for controlling two independent circuits.
- Interchangeable with OMRON Z Basic Switches, as both switches are identical in mounting hole dimensions, mounting pitch and pin plunger position.



Model Number Structure

Model Number Legend

DZ-10G□-1□
1 2 3 4 5

1. Ratings

10: 10 A (250 VAC)

2. Contact Gap

G: 0.5 mm

3. Actuator

None: Pin plunger

V: Hinge lever

V22: Short hinge roller lever

V2: Hinge roller lever

W: Hinge lever

W22: Short hinge roller lever

W2: Hinge roller lever

4. Contact Form

1: DPDT





5. Terminals

A: Solder terminal

B: Screw terminal

Ordering Information

List of Models

Actuator	OT	Solder terminal	Screw terminal
Pin plunger 	0.13 mm min.	DZ-10G-1A	DZ-10G-1B
Hinge lever 	1.6 mm min.	DZ-10GW-1A	DZ-10GW-1B
	0.4 mm min.	DZ-10GV-1A	DZ-10GV-1B
Short hinge roller lever 	0.9 mm min.	DZ-10GW22-1A	DZ-10GW22-1B
	0.13 mm min.	DZ-10GV22-1A	DZ-10GV22-1B
Hinge roller lever 	1.2 mm min.	DZ-10GW2-1A	DZ-10GW2-1B
	0.26 mm min.	DZ-10GV2-1A	DZ-10GV2-1B

Limit Switches

Specifications

■ Approved Standards

Agency	Standard	File No.
UL	UL508	E41515
CSA	CSA C22.2 No. 55	LR21642

■ Approved Standard Ratings

**UL508 (File No. E41515)/
CSA C22.2 No. 55 (File No. LR21642)**

Rated voltage	DZ-10G
125 VAC	10 A 1/3 HP
250 VAC	10 A 1/4 HP
480 VAC	2 A
125 VDC	0.5 A
250 VDC	0.25 A

■ Ratings

Rated voltage	Non-inductive load				Inductive load				Inrush current	
	Resistive load		Lamp load		Inductive load		Motor load		NC	NO
	NC	NO	NC	NO	NC	NO	NC	NO		
125 VAC	10 A		2 A	1 A	6 A		3 A	1.5 A	30 A max.	15 A max.
250 VAC	10 A		1.5 A	0.7 A	4 A		2 A	1 A		
8 VDC	10 A		3 A	1.5 A	6 A		5 A	2.5 A		
14 VDC	10 A		3 A	1.5 A	6 A		5 A	2.5 A		
30 VDC	10 A		3 A	1.5 A	4 A		3 A	1.5 A		
125 VAC	0.5 A		0.5 A		0.05 A		0.05 A			
250 VDC	0.25 A		0.25 A		0.03 A		0.03 A			

- Note:** 1. Inductive load has a power factor of 0.4 min. (AC) and a time constant of 7 ms max. (DC).
 2. Lamp load has an inrush current of 10 times the steady-state current.
 3. Motor load has an inrush current of 6 times the steady-state current.

■ Characteristics

Operating speed	0.1 mm to 1 m/s (at pin plunger)
Operating frequency	Mechanical: 240 operations/min Electrical: 20 operations/min
Insulation resistance	100 MΩ min. (at 500 VDC)
Contact resistance	15 mΩ max. (initial value)
Dielectric strength	1,000 VAC, 50/60 Hz for 1 min between non-continuous terminals 1,500 VAC, 50/60 Hz for 1 min between current-carrying metal parts and non-current-carrying metal part, and between current-carrying metal part and ground and between switches
Vibration resistance	Malfunction: 10 to 55 Hz, 1.5-mm double amplitude
Shock resistance	Destruction: 1,000 m/s ² {approx. 100G} max. Malfunction: 300 m/s ² {approx. 30G} max. (See notes 1 and 2.)
Durability	Mechanical: 1,000,000 operations min. Electrical: 500,000 operations min.
Ambient temperature	Operating: -25°C to 80°C (with no icing)
Ambient humidity	Operating: 35% to 85% max.
Weight	Approx. 30 to 50 g

- Note:** 1. The values are for pin plunger models. (Contact your OMRON representative for other models.)
 2. Malfunction: 1 ms max.

■ Contact Form (DPDT)

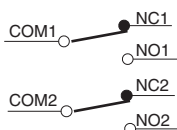

Engineering Data

■ Mechanical Durability (Pin Plunger)

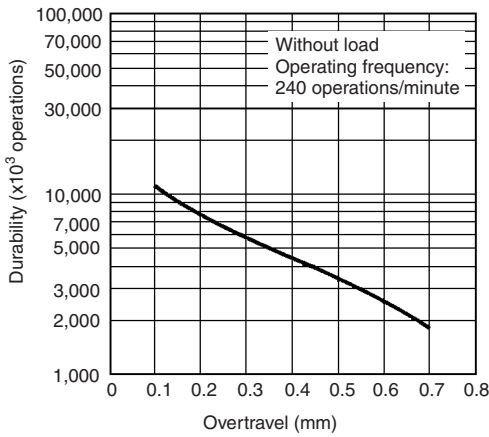

■ Electrical Durability (Pin Plunger)

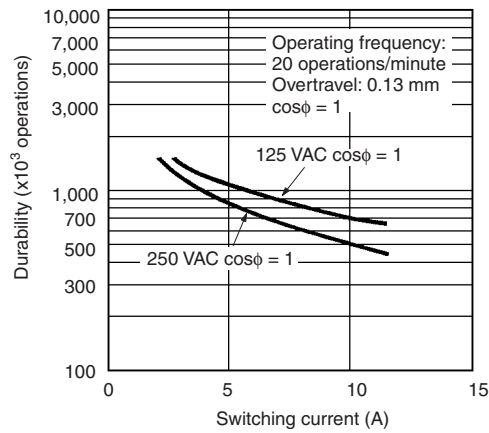

Dimensions

■ Dimensions and Operating Characteristics

Note: 1. All units are in millimeters unless otherwise indicated.

2. Unless otherwise specified, a tolerance of ± 0.4 mm applies to all dimensions.

3. The solder terminal model has a suffix "-1A" in its model number and its omitted dimensions are the same as the corresponding dimensions of the pin plunger model.

Pin Plunger

DZ-10G-1B

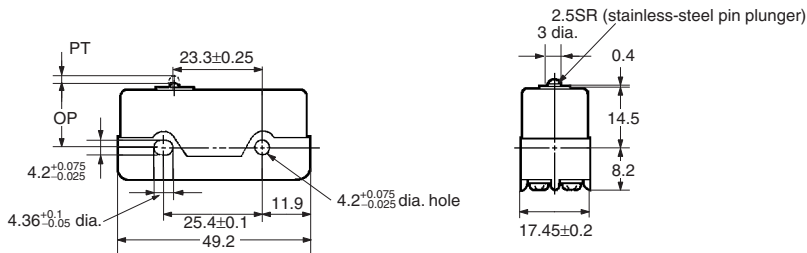

OF max.	5.59 N {570 gf}
RF min.	0.55 N {57 gf}
PT max.	1.7 mm
OT min.	0.13 mm
MD max.	0.4 mm
OP	15.6±0.4 mm

Hinge Lever

DZ-10GW-1B

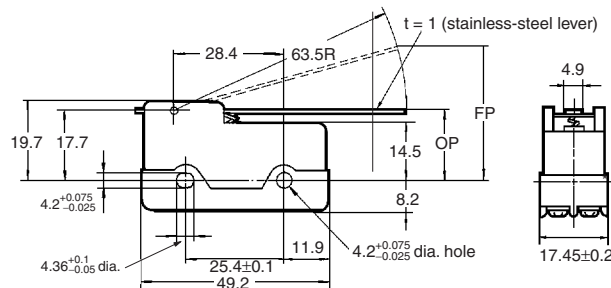
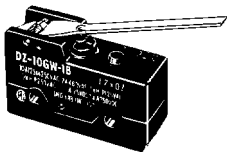

OF max.	1.67 N {170 gf}
RF min.	0.27 N {28 gf}
OT min.	1.6 mm
MD max.	4 mm
FP max.	46.3 mm
OP	21.8±1 mm

DZ-10GV-1B

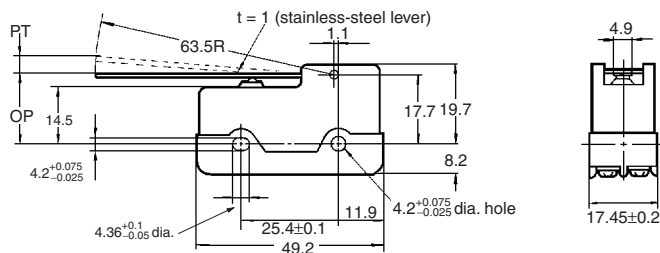
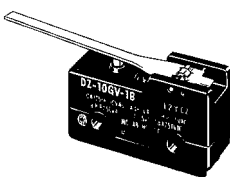

OF max.	1.96 N {200 gf}
RF min.	0.13 N {14 gf}
PT max.	6 mm
OT min.	0.4 mm
MD max.	1.7 mm
OP	18.3±1 mm

Short Hinge Roller Lever

DZ-10GW22-1B

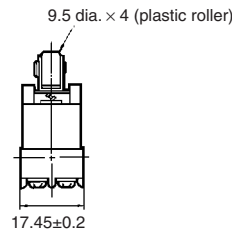
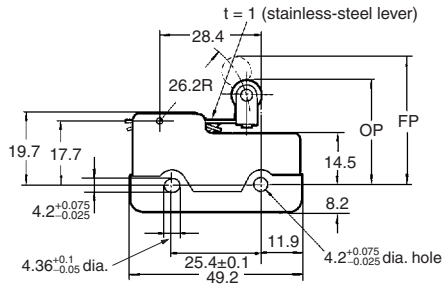

OF max.	3.92 N {400 gf}
RF min.	0.83 N {85 gf}
OT min.	0.9 mm
MD max.	2.4 mm
FP max.	39.7 mm
OP	30.2±0.8 mm

DZ-10GV22-1B

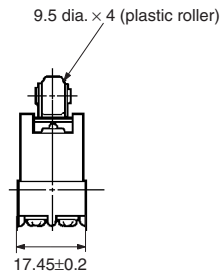
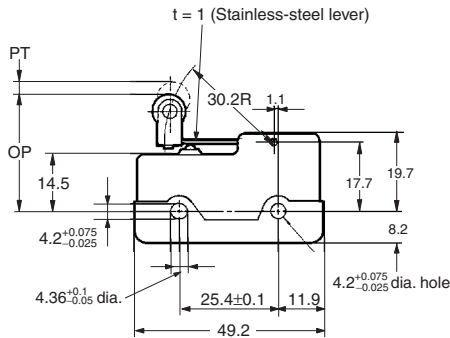

OF max.	4.22 N {430 gf}
RF min.	0.41 N {42 gf}
PT max.	3 mm
OT min.	0.13 mm
MD max.	0.6 mm
OP	29.4±0.8 mm

Hinge Roller Lever

DZ-10GW2-1B

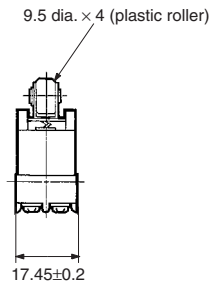
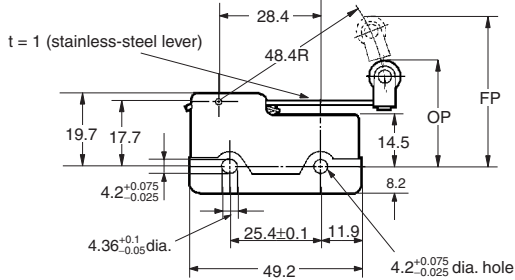
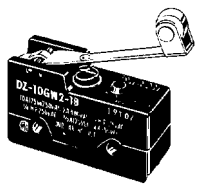

OF max.	2.09 N {213 gf}
RF min.	0.41 N {42 gf}
OT min.	1.2 mm
MD max.	3.3 mm
FP max.	47.6 mm
OP	31.8±0.8 mm

DZ-10GV2-1B

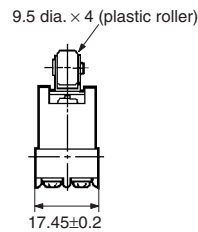
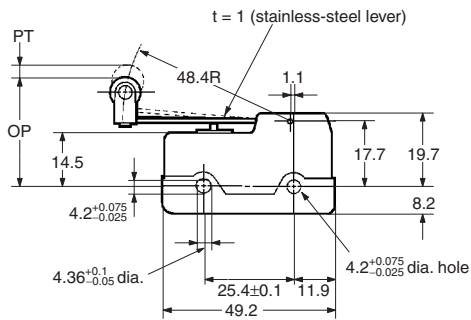
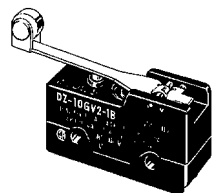

OF max.	2.65 N {270 gf}
RF min.	0.33 N {34 gf}
PT max.	4 mm
OT min.	0.26 mm
MD max.	1.1 mm
OP	29.4±0.8 mm

■ Terminals

Solder Terminals (-1A)

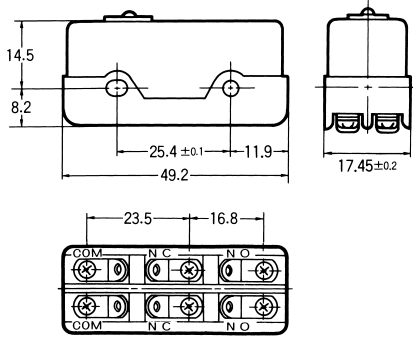

Screw Terminals (-1B)

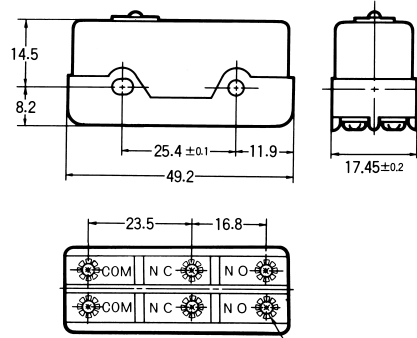

Six M3 pan head screws
(with toothed washer)

Precautions

Refer to the *Technical Information for Basic Switches* (Cat. No. C122) for common precautions.

■ Cautions

Terminal Connection

When soldering lead wires to the Switch, make sure that the capacity of the soldering iron is 60 W maximum. Do not take more than 5 s to solder any part of the Switch. Improper soldering may cause abnormal heat radiation from the Switch and the Switch may burn.

The characteristics of the Switch will deteriorate if a soldering iron with a capacity of more than 60 W is applied to any part of the Switch for 6 s or more.

Operation

Make sure that the switching frequency or speed is within the specified range.

If the switching speed is extremely slow, the contact may not be switched smoothly, which may result in a contact failure or contact welding.

If the switching speed is extremely fast, switching shock may damage the Switch soon. If the switching frequency is too high, the contact may not catch up with the speed.

The rated permissible switching speed and frequency indicate the switching reliability of the Switch.

The life of a Switch is determined at the specified switching speed. The life varies with the switching speed and frequency even when they are within the permissible ranges. In order to determine the life of a Switch model to be applied to a particular use, it is best to conduct an appropriate durability test on some samples of the model under actual conditions.

Make sure that the actuator travel does not exceed the permissible OT position. The operating stroke must be set to 70% to 100% of the rated OT.

■ Correct Use

Mounting

Use M4 mounting screws with plane washers or spring washers to securely mount the Switch. Tighten the screws to a torque of 1.18 to 1.47 N·m {12 to 15 kgf·cm}

Mounting Holes

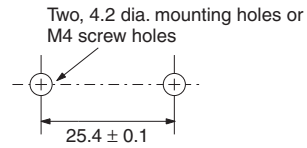

■ Accessories (Order separately)

Refer to *Z/A/X/DZ Common Accessories* for details about Terminal Covers, Separators, and Actuators.

ALL DIMENSIONS SHOWN ARE IN MILLIMETERS.

To convert millimeters into inches, multiply by 0.03937. To convert grams into ounces, multiply by 0.03527.

Cat. No. B060-E1-07

In the interest of product improvement, specifications are subject to change without notice.