

# Enclosed Switch SHL

## Subminiature Enclosed Switch (Measuring 48 x 17.5 x 45 mm) with High Sealing Property

- Built-in coil spring type basic switch housed in rigid zinc diecast alloy casting boasts long life and high precision.
- Requires nearly the same operating force as conventional basic precision switches (2.35 to 3.92 N).
- Molded terminal model is available.
- Operation indicator model is also available.

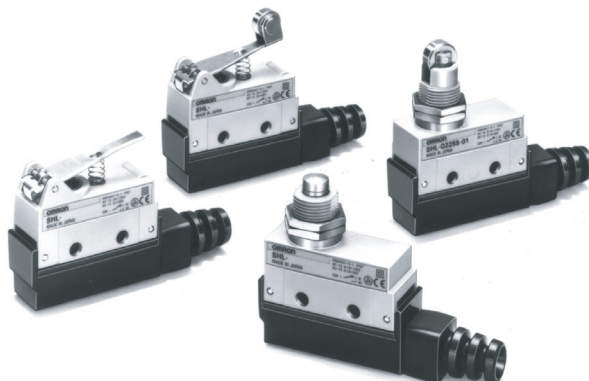

## Model Number Structure

### Model Number Legend

#### Standard Models

SHL-□55-□  
1 2

#### 1. Actuator

- D: Plunger
- Q: Panel mount plunger
- Q22: Panel mount roller plunger
- Q21: Panel mount crossroller plunger
- W: Short hinge lever
- W1: Hinge lever
- W2: Short hinge roller lever
- W21: Hinge roller lever
- W3: One-way action short hinge roller lever
- W31: One-way action hinge roller lever





#### 2. Rated Current





- None: Standard
- 01: Micro Load

**Note:** Refer to page 53 for *Molded Terminal Models*.

## Ordering Information

### List of Models

Actuator		Standard model	Micro voltage
Plunger		SHL-D55	SHL-D55-01
Panel mount plunger		SHL-Q55	SHL-Q55-01
Panel mount roller plunger		SHL-Q2255	SHL-Q2255-01
Panel mount crossroller plunger		SHL-Q2155	SHL-Q2155-01
Short hinge lever		SHL-W55	SHL-W55-01

Actuator	Standard model	Micro voltage
Hinge lever 	SHL-W155	SHL-W155-01
Short hinge roller lever 	SHL-W255	SHL-W255-01
Hinge roller lever 	SHL-W2155	SHL-W2155-01
One-way action short hinge roller lever 	SHL-W355	SHL-W355-01
One-way action hinge roller lever 	SHL-W3155	SHL-W3155-01

## Specifications

### ■ Approved Standards

Agency	Standard	File No.
UL	UL508	E76675
CSA	CSA C22.2 No. 14	LR45746
TÜV Rheinland	EN60947-5-1	R9451332

### ■ Approved Standard Ratings

#### UL/CSA

#### A300

Rated voltage	Carry current	Current		Volt-amperes	
		Make	Break	Make	Break
120 VAC	10 A	60 A	6 A	7,200 VA	720 VA
240 VAC		30 A	3 A		

#### TÜV Rheinland Approved Ratings (EN60947-5-1)

Model	Category and rating	I the
SHL-□55	AC-15 2 A/125 V DC-12 2 A/48 V	5 A 4 A
SHL-□55-01	AC-14 0.1 A/125 V DC-12 0.1 A/48 V	0.5 A 0.5 A
SHL-□55-L	AC-15 2 A/125 V	5 A
SHL-□55-01L	AC-14 0.1 A/125 V	0.5 A
SHL-□55-01L2	DC-12 0.1 A/12 V	0.5 A
SHL-□55-L3	DC-12 2 A/24 V	4 A
SHL-□55-01L3	DC-12 0.1 A/24 V	0.5 A
SHL-□55-L4	DC-12 2 A/24 V	4 A
SHL-□55-01L4	DC-12 0.1 A/24 V	0.5 A
SHL-□55-L5	DC-12 2 A/48 V	4 A
SHL-□55-01L5	DC-12 0.1 A/48 V	0.5 A

**Note:** For details on the above models, refer to *Model Number Legend* under *Molded Terminal Models*.

## ■ Ratings

Rated voltage	Non-inductive load				Inductive load				Inrush current	
	Resistive load		Lamp load		Inductive load		Motor load		NC	NO
	NC	NO	NC	NO	NC	NO	NC	NO		
125 VAC	10 A		1.5 A		3 A		2.5 A		15 A max.	
250 VAC	10 A		1.5 A		2 A		1.5 A			
480 VAC	2 A		---		---		---			
8 VDC	10 A		2 A		5 A		2 A			
14 VDC	10 A		2 A		5 A		2 A			
30 VDC	5 A		1.5 A		1.5 A		1.5 A			
125 VDC	0.4 A		0.4 A		0.05 A		0.05 A			
250 VDC	0.2 A		0.2 A		0.03 A		0.03 A			

- Note:**
1. The above figures are for steady-state currents.
  2. Inductive loads have a power factor of 0.4 min. (AC) and a time constant of 7 ms max. (DC).
  3. Lamp load has an inrush current of 10 times the steady-state current.
  4. Motor load has an inrush current of 6 times the steady-state current.

### Micro Voltage/Current Load Model

Rated voltage	Non-inductive load	
	Resistive load	
	NC	NO
125 VAC	0.1 A	
8 VDC	0.1 A	
14 VDC	0.1 A	
30 VDC	0.1 A	

## ■ Characteristics

Degree of protections (see note 3)	IP67 (EN60947-5-1)
Durability (see note 4)	Mechanical: 10,000,000 operations min. Electrical: 500,000 operations min.
Operating speed	0.1 mm to 0.5 m/s (hinge lever models)
Operating frequency	Mechanical: 120 operations/min Electrical: 30 operations/min
Rated frequency	50/60 Hz
Insulation resistance	100 MΩ min. (at 500 VDC)
Contact resistance	15 mΩ max.(initial value)
Dielectric strength	1,000 VAC, 50/60 Hz for 1 min between terminals of the same polarity 2,000 VAC, 50/60 Hz for 1 min/Uimp at 2.5 kV (EN60947-5-1) between current-carrying metal part and ground, and between each terminal and non-current-carrying metal part
Rated insulation voltage (U <sub>i</sub> )	150 V (EN60947-5-1)
Switching overvoltage	1,000 VAC max., 300 VDC max. (EN60947-5-1)
Pollution degree (operating environment)	3 (EN60947-5-1)
Short-circuit protective device (SCPD)	10 A fuse type gG (IEC269)
Conditional short-circuit current	100 A (EN60947-5-1)
Conventional enclosed thermal current (I <sub>the</sub> )	5 A (EN60947-5-1)
Protection against electric shock	Class II (grounding not required with double insulation)
OFF reverse voltage	1,000 VAC max., 300 VDC max. (EN60947-5-1)
Vibration resistance	Malfunction: 10 to 55 Hz, 1.5-mm double amplitude
Shock resistance	Destruction: 1,000 m/s <sup>2</sup> min. Malfunction: 300 m/s <sup>2</sup> min.
Ambient temperature	Operating: -10°C to 80°C (no icing)
Ambient humidity	Operating: 95% max.
Weight (see note 5)	Approx. 62 to 72 g

- Note:**
1. The above figures are for standard currents.
  2. The above ratings may vary depending on the model. Contact your OMRON representative for further details.
  3. The head section of the plunger type SHL-D(Q)□□ is excluded.
  4. Durability values are calculated at an operating temperature of 5°C to 35°C, and an operating humidity of 40% to 70%. Contact your OMRON sales representative for more detailed information on other operating environments.
  5. The values are for the plunger-type models.

## ■ Operating Characteristics

Model	SHL-D55 SHL-D55-01	SHL-Q55 SHL-Q55-01	SHL-Q2255 SHL-Q2255-01	SHL-Q2155 SHL-Q2155-01	SHL-W55 SHL-W55-01
OF max.	9.81 N	9.81 N	9.81 N	9.81 N	3.14 N
RF min.	1.96 N	1.96 N	1.96 N	1.96 N	0.78 N
PT max.	1.5 mm	1.5 mm	1.5 mm	1.5 mm	8 mm
OT min.	2 mm	2 mm	2 mm	2 mm	3 mm
MD max.	0.5 mm	0.5 mm	0.5 mm	0.5 mm	2.5 mm
OP	34±0.8 mm	34±0.8 mm	43±0.8 mm	43±0.8 mm	21.5±1 mm
FP max.	---	---	---	---	29.5 mm

Model	SHL-W155 SHL-W155-01	SHL-W255 SHL-W255-01	SHL-W2155 SHL-W2155-01	SHL-W355 SHL-W355-01	SHL-W3155 SHL-W3155-01
OF max.	2.35 N	3.92 N	2.55 N	3.92 N	2.55 N
RF min.	0.44 N	0.78 N	0.49 N	0.78 N	0.49 N
PT max.	13 mm	8 mm	13 mm	8 mm	13 mm
OT min.	5 mm	3 mm	5.5 mm	3 mm	5.5 mm
MD max.	4 mm	2.5 mm	4 mm	2.5 mm	4 mm
OP	21.5±1 mm	33±1 mm	33.5±1 mm	44.5±1 mm	44.5±1 mm
FP max.	34.5 mm	41 mm	46.5 mm	52.5 mm	57.5 mm

## ■ Contact Form

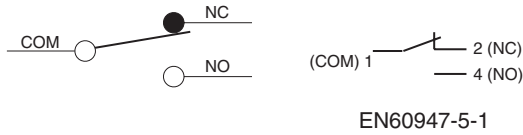

## Engineering Data

### ■ Electrical Durability

Ambient temperature: 5°C to 35°C  
 Ambient humidity: 40% to 50%

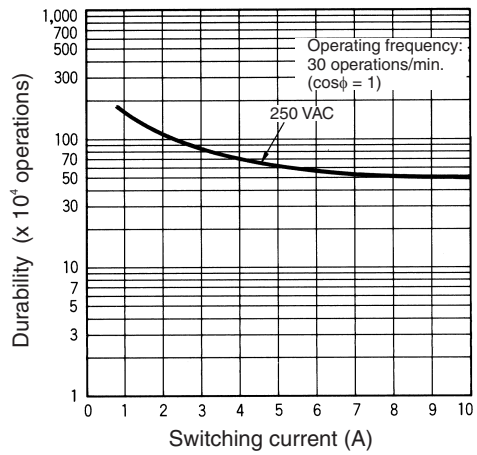

Limit Switches

## Nomenclature

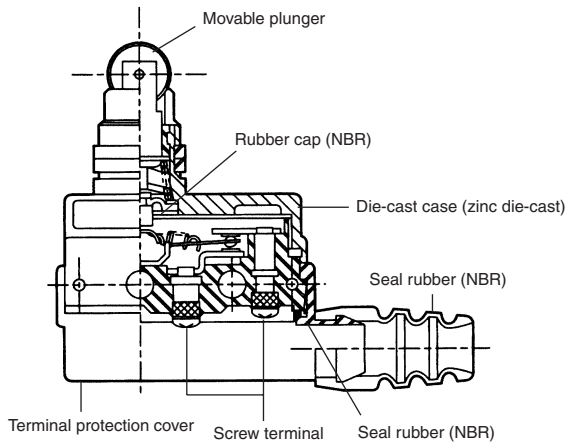

# Dimensions

**Note:** 1. All units are in millimeters unless otherwise indicated.  
 2. Unless otherwise specified, a tolerance of  $\pm 0.4$  mm applies to all dimensions.

## Plunger SHL-D55, SHL-D55-01

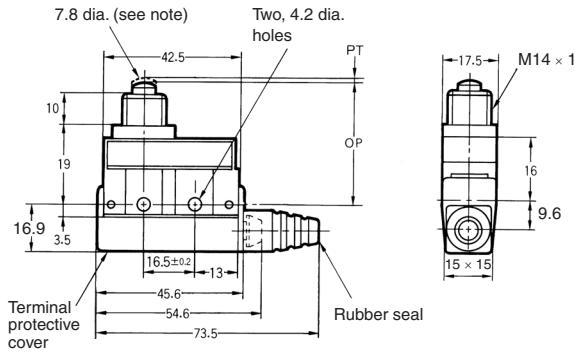
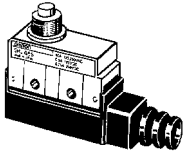

**Note:** Stainless steel pin plunger

## Panel Mount Plunger SHL-Q55, SHL-Q55-01

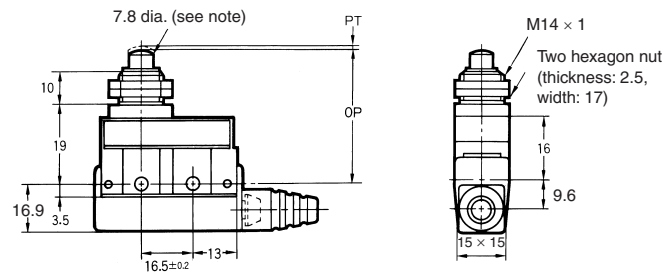
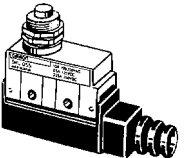

**Note:** Stainless steel pin plunger

## Panel Mount Roller Plunger SHL-Q2255, SHL-Q2255-01

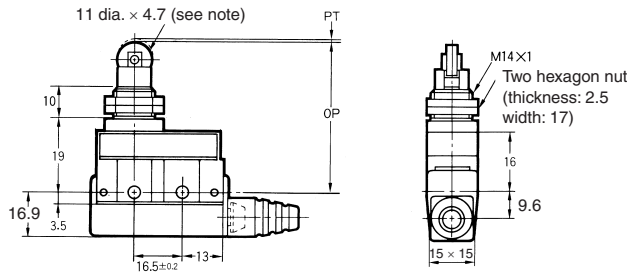
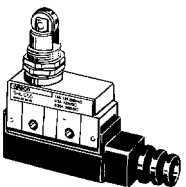

**Note:** Stainless sintered alloy roller

## Panel Mount Crossroller Plunger SHL-Q2155, SHL-Q2155-01

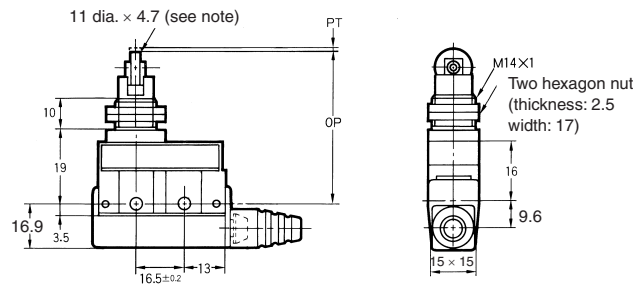
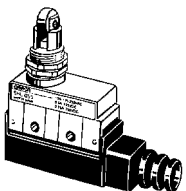

**Note:** Stainless sintered alloy roller

**Short Hinge Lever**  
SHL-W55, SHL-W55-01

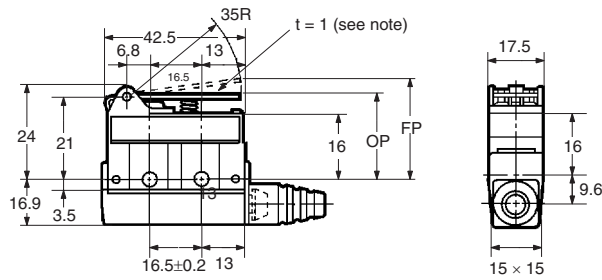
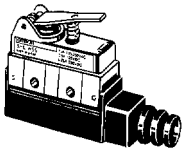

Note: Stainless steel lever

**Hinge Lever**  
SHL-W155, SHL-W155-01

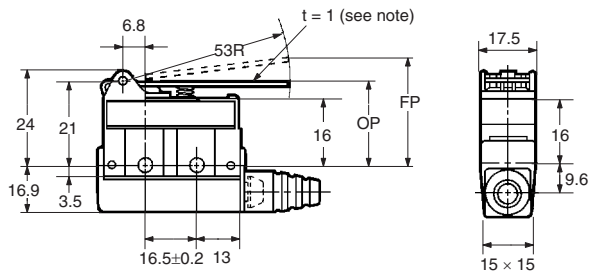
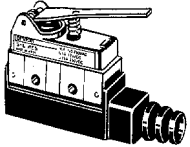

Note: Stainless steel lever

**Short Hinge Roller Lever**  
SHL-W255, SHL-W255-01

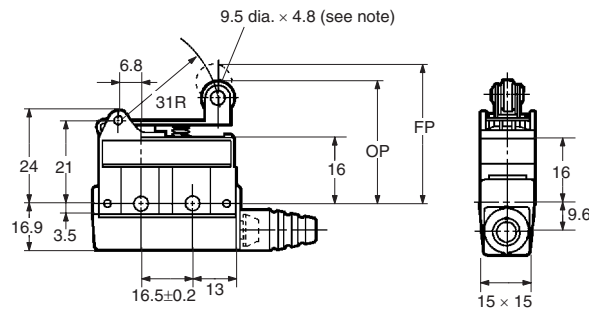
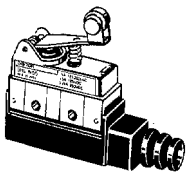

Note: Sintered stainless roller

**Hinge Roller Lever**  
SHL-W2155, SHL-W2155-01

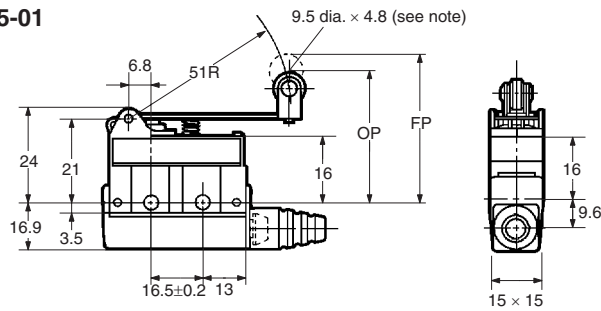
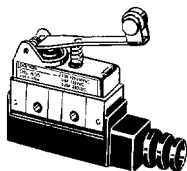

Note: Sintered stainless roller

**One-way Action Short Hinge Roller Lever**  
**SHL-W355, SHL-W355-01**

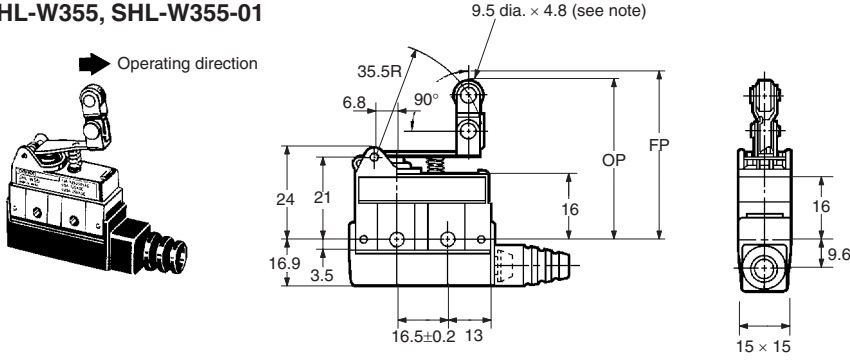

**One-way Action Hinge Roller Lever**  
**SHL-W3155, SHL-W3155-01**

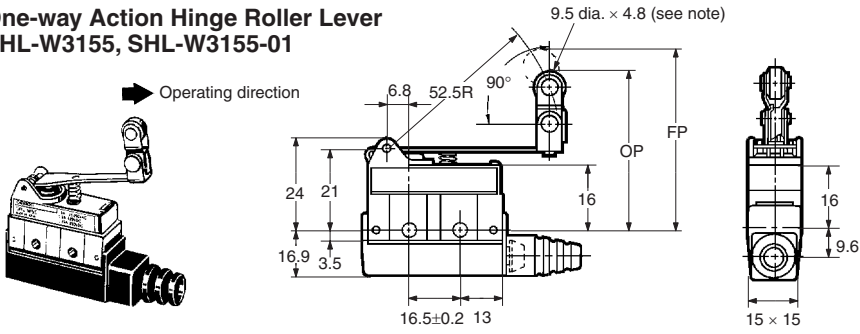



# Molded Terminal Models

## Model Number Legend

### Molded Terminal Models

SHL-□55-□□□M□  
 1 2 3 4

Items 1 (Actuator) and 2 (Rated Current) are the same as those in *Standard Models*.

#### 3. Operation Indicator

- None: Not provided
- L: Neon Lamp: 90 to 250 VAC
- L2: LED: 12 V
- L3: LED: 24 V
- L4: LED: 24 V
- L5: LED: 48 V

#### 4. Location of Lead Outlet

- R: Right-hand
- L: Left-hand
- D: Underside

Use of the molded terminal model is recommended in locations subject to excessive dust, oil drips, or moisture.

All types of SHL Switches can be fabricated into a molded terminal version. In this case, the molded terminal model will have the same dimensions an operating characteristics as the basic model from which the molded terminal model is fabricated.

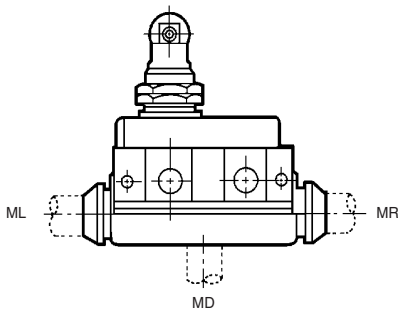

#### Suffix by Location of Lead Outlet

Location of lead outlet	Model
Right-hand	SHL-□-MR
Left-hand	SHL-□-ML
Underside	SHL-□-MD

**Note:** Three leads (COM, NO, and NC) are provided for terminal connections.

#### Example:

Basic type: SHL-Q2255  
 Location of lead outlet: Right-hand  
 When placing your order for the above Switch specify the model number as SHL-Q2255-MR

### Lead Supplies

Leads	Nominal cross-sectional area	No. of conductors/cond. dia.	Finished outside diameter	Terminal connections	Standard length
VCTF (Vinyl cabtire cable)	0.75 mm <sup>2</sup>	30/0.18 dia.	3-core 7 dia.	Black: COM White: NO Red: NC	3 m

## Operation Indicator-equipped Models

UL, CSA and/or EN (IEC) approved models are available.

The molded terminal model may be equipped with an operation indicator (neon lamp or LED) upon request to facilitate maintenance and inspection.

The operation indicator is designed to illuminate when the Switch is not operating. (Because of the molded terminal model, any change to the Switch wiring cannot be made.)

### AC Operation

A neon lamp indicator is provided.  
 The operating voltage is 90 to 250 VAC.

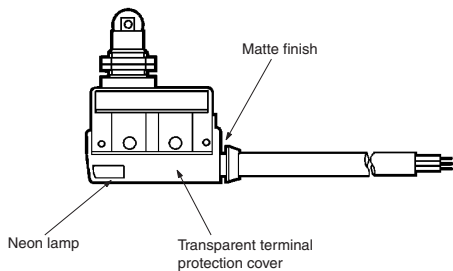

Operating characteristics are the same as the basic model from which the operation indicator equipped model is fabricated.

Dimension are the same as the standard model.

#### Example:

Basic type: SHL-Q2255-01MR  
 When placing your order for the molded terminal model with an neon lamp operation indicator, specify the model number as SHL-Q2255-01LMR.

### Contact Circuit

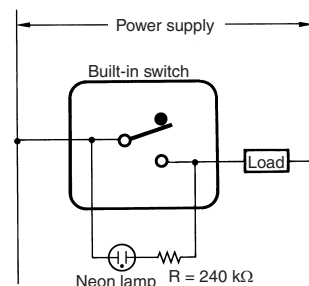

## DC Operation

LED indicator is provided.

As a rectifier stack is incorporated, into the unit and no directionality exists for connection of + and -, this type can also be operated on AC.

Voltage ratings of LED indicators are as shown in the table below.

The Switch case has a protrusion to facilitate visual confirmation of LED indicator.

### Example:

Basic type: SHL-Q2255-01MR

When placing your order for the molded terminal with an LED indicator rated at 12 V, specify the model number as SHL-Q2255-01L2MR.

## Contact Circuit

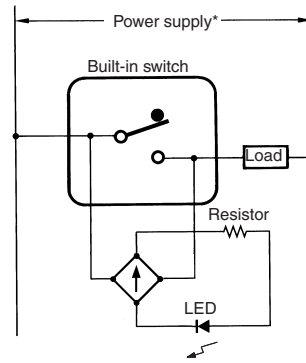

\*An external power supply can be used, eg. OMRON S8VS.

Type	Voltage rating	Lamp current	Internal resistance
L2	12 V	Approx. 2.4 mA	4.3 kΩ
L3	24 V	Approx. 2 mA	10 kΩ
L4	24 V	Approx. 1.2 mA	18 kΩ
L5	48 V	Approx. 2.1 mA	22 kΩ

## Precautions

### Correct Use

Be sure to connect a fuse with a breaking current 1.5 to 2 times the rated current to the Limit Switch in series in order to protect the Limit Switch from damage due to short-circuiting.

When using the Limit under the EN ratings, use a gI or gG 10-A fuse that conforms to IEC260.

### Handling

When detaching the Terminal Protective Cover, insert a screwdriver and apply a force in the opening direction. Do not use excess force to remove the cover. Doing so may cause deformation in the fitting section and reduce the holding force.

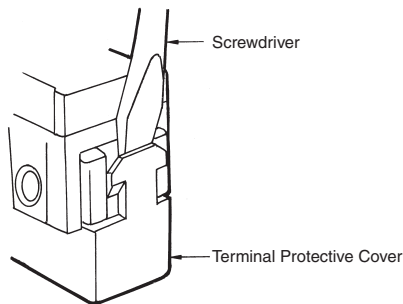

When mounting the Terminal Protective Cover to the case, align the cover on the case and then press the cover down to mount it firmly. If the cover is pressed down in an inclined position, rubber packing will deform and thus affect the sealing capability.

### Mounting

Secure the Switch with two M4 screws and washers. The tightening torque applied to each terminal must be 1.18 to 1.37 N·m. Tighten the screws to the specified torque. An excessive tightening torque may damage the Switch and cause a malfunction.

When mounting the panel mount-type Switch with screws on a side surface, remove the hexagonal nuts from the actuator.

### Mounting Holes

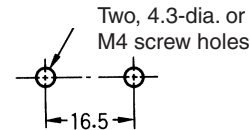

When mounting the panel mount type (SHL-Q55, SHL-Q2255, or SHL-Q2155) on a panel, tighten the hexagonal nuts of the actuator to a torque less than 7.84 N·m.

### Tightening Torque

A loose screw may result in a malfunction. Be sure to tighten each screw to the proper tightening torque as shown below.

No.	Type	Torque
1	Terminal screw (M3 screw)	0.24 to 0.44 N·m
2	Panel mounting screw (M4 screw)	1.18 to 1.37 N·m

When wiring, use M3 round solderless terminals and apply insulation shielding to the connections. Tighten the terminals screws to 0.24 to 0.44 N·m.

### Operating Stroke

Ensure that the operating stroke for roller plunger models is within the set position display.

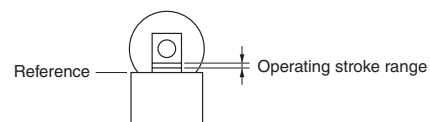

## Micro Load Applicable Ranges

When using a Limit Switch for opening or closing micro-load circuit (zones 1 through 3), contact failure may occur if a Limit Switch with ordinary contact specifications is used. Therefore, when using Limit Switches in the micro-load range, use ones with contact specifications that are suited to each zone.

Use the SHL-□-01 micro-load models within the zones (1 through 3) shown in the following diagram.

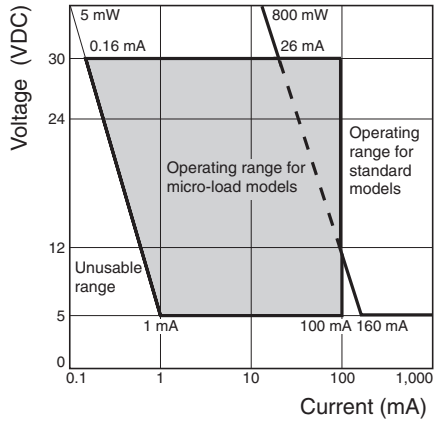

The above diagram is for standard conditions (5°C to 35°C, 40% to 70%). Since the values vary depending on the operating environment conditions, contact your OMRON representative for further details.

## Others

The standard seal rubber for the lead wire outlet is one that allows 6- to 8-dia. cables. The appropriate nominal cross-section of the lead wire is 0.75 mm<sup>2</sup>. (When the sealing capability is required over a long period of time, use mold specifications.)

ALL DIMENSIONS SHOWN ARE IN MILLIMETERS.

To convert millimeters into inches, multiply by 0.03937. To convert grams into ounces, multiply by 0.03527.

Cat. No. C026-E1-09

In the interest of product improvement, specifications are subject to change without notice.