

Economical, High Utility Enclosed Switch

- High precision and long life (10,000,000 mechanical operations) through employment of the moving spring used in OMRON Z Basic Switch.
- Sealed with gasket diaphragm to provide high sealing property without use of any adhesive or pin.
- Suitable for applications demanding higher mechanical strength, dustproof and drip-proof properties than those on basic switches.
- Panel mount versions have the same operating position as Z Basic Switch.
- Resin molded terminal versions are available.



Ordering Information









■ Model Number Legend

D4MC-

1. Actuator

- 5000: Panel mount plunger
- 5020: Panel mount roller plunger
- 5040: Panel mount crossroller plunger
- 1020: Short hinge lever
- 1000: Hinge lever
- 2000: Hinge roller lever
- 2020: Short hinge roller lever
- 3030: One-way action short hinge roller lever

■ List of Models

Actuator	Model
Panel mount plunger 	D4MC-5000
Panel mount roller plunger 	D4MC-5020
Panel mount crossroller plunger 	D4MC-5040
Short hinge lever 	D4MC-1020
Hinge lever 	D4MC-1000
Hinge roller lever 	D4MC-2000
Short hinge roller lever 	D4MC-2020
One-way action short hinge roller lever 	D4MC-3030

- Note:**
1. Use molded terminal models (refer to page 209) when using the Switch under one of the following conditions:
 - a) dusty, b) high amount of dripping oil, or c) high humidity
 2. Micro-load models are available.

e.g. Standard model	Micro-load model
D4MC-5020	D4MC-5020-C

Specifications

■ Ratings

Rated voltage	Non-inductive load				Inductive load			
	Resistive load		Lamp load		Inductive load		Motor load	
	NC	NO	NC	NO	NC	NO	NC	NO
125 VAC	10 A		3 A	1.5 A	10 A		5 A	2.5 A
250 VAC	10 A		2.5 A	1.25 A	10 A		3 A	1.5 A
480 VAC	3 A		1.5 A	0.75 A	2.5 A		1.5 A	0.75 A
8 VDC	10 A		3 A	1.5 A	6 A		5 A	2.5 A
14 VDC	10 A		3 A	1.5 A	6 A		5 A	2.5 A
30 VDC	6 A		3 A	1.5 A	5 A		5 A	2.5 A
125 VDC	0.5 A		0.4 A		0.05 A		0.05 A	
250 VDC	0.25 A		0.2 A		0.03 A		0.03 A	

Inrush current	NC	30 A max.
	NO	15 A max.

- Note:**
- The above figures are for steady-state currents.
 - Inductive loads have a power factor of 0.4 min. (AC) and a time constant of 7 ms max. (DC).
 - Lamp load has an inrush current of 10 times the steady-state current.
 - Motor load has an inrush current of 6 times the steady-state current.
 - The above ratings were tested under the following conditions according to JIS C4508.
 - Ambient temperature: 20±2°C
 - Ambient humidity: 65±5%
 - Operating frequency: 20 operations/min

■ Approved Standard Ratings

UL/CSA

A300

Rated voltage	Carry current	Current		Volt-amperes	
		Make	Break	Make	Break
120 VAC	10 A	60 A	6 A	7,200 VA	720 VA
240 VAC		30 A	3 A		

Micro load: 0.1 A, 125 VAC
0.1 A, 30 VDC

EN60947-1 and EN60947-5-1

250 V, 10 A (AC-12)

■ Characteristics

Degree of protection	IP67 (NEMA250: 6.6P)
Life expectancy	Mechanical: 10,000,000 operations min. Electrical: 500,000 operations min.
Operating speed	0.05 mm/s to 0.5 m/s (at panel mount plunger)
Operating frequency	Mechanical: 120 operations/min Electrical: 20 operations/min
Insulation resistance	100 MΩ min. (at 500 VDC)
Contact resistance	15 mΩ max. (initial value)
Dielectric strength	1,000 VAC, 50/60 Hz for 1 min between terminals of the same polarity 2,000 VAC, 50/60 Hz for 1 min between current-carrying metal parts and ground, and between each terminal and non-current-carrying part
Rated insulation voltage (U _i)	1,000 VAC
Pollution degree (operating environment)	3 (IEC947-5-1)
Protection against electric shock	Class II
PTI (tracking characteristics)	175
Switch category	D (IEC335)
Rated operating current (I _e)	10 A
Rated operating voltage (U _e)	250 VAC
Vibration resistance	Malfunction: 10 to 55 Hz, 1.5-mm double amplitude (see note)
Shock resistance	Destruction: 1,000 m/s ² min. Malfunction: 100 m/s ² min. (in case of plunger) (see note)
Ambient temperature	Operating: -10°C to 80°C (with no icing)
Ambient humidity	Operating: 35% to 95%
Weight	Approx. 71 g (at panel mount plunger)

Note: Less than 1 ms under a free state at the operating limits.

■ Approved Standards (Except Molded Terminal Models)

UL (File No. E76675)/CSA (File No. E45258)

■ Operating Characteristics

Model	D4MC-5000	D4MC-5020	D4MC-5040	D4MC-1020	D4MC-1000	D4MC-2000	D4MC-2020	D4MC-3030
OF max.	5.88 N	5.88 N		2.55 N	1.67 N	1.96 N	2.94 N	2.94 N
RF min.	0.98 N	0.98 N		0.34 N	0.25 N	0.39 N	0.39 N	0.39 N
PT max.	1.6 mm	1.6 mm		---	---	---	---	---
OT min.	5 mm	5 mm		2.5 mm	4 mm	5 mm	2 mm	2 mm
MD max.	0.2 mm	0.2 mm		1.7 mm	3 mm	3 mm	1.5 mm	1.5 mm
OP	21.8± 1.2 mm	33.4±1.2 mm		25±1 mm	25±1 mm	40±1 mm	40±1 mm	50±1 mm
FP max.	---	---		33 mm	36 mm	51 mm	47 mm	57.2 mm

Engineering Data (Reference Data)

Mechanical Life Expectancy (D4MC-5000)

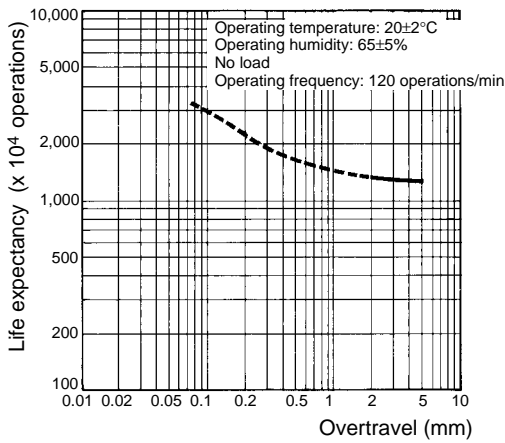

Electrical Life Expectancy

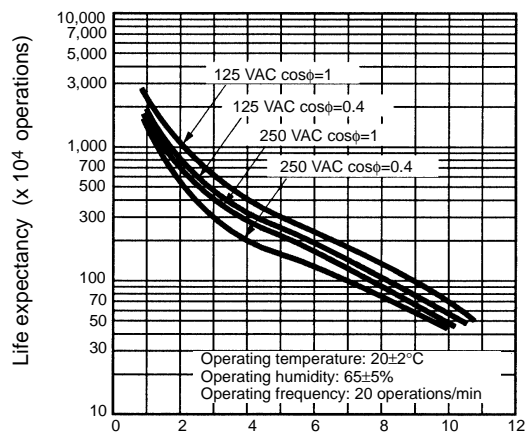

Operation

Contact Form

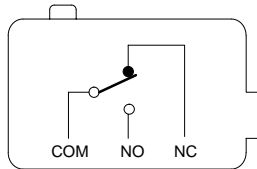

Dimensions

- Note:**
- All units are in millimeters unless otherwise indicated.
 - Unless otherwise specified, a tolerance of ±0.4 mm applies to all dimensions.

Panel Mount Plunger D4MC-5000

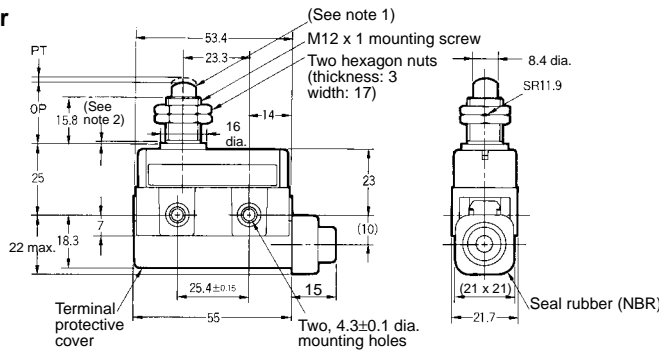

- Note:**
- Stainless steel plunger
 - The length of the imperfect threads is 1.5 mm maximum.

Panel Mount Roller Plunger D4MC-5020

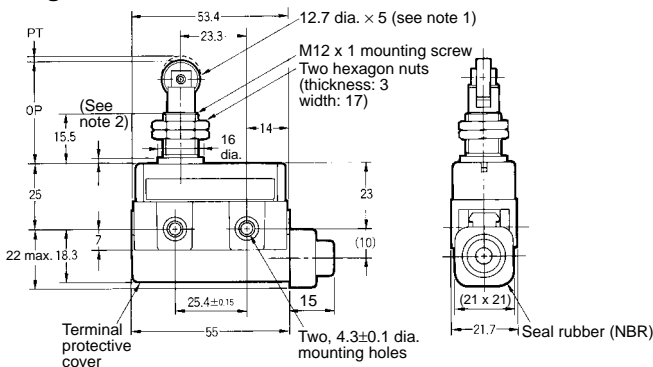

- Note:**
- Stainless steel roller
 - The length of the imperfect threads is 1.5 mm maximum.

**Panel Mount Crossroller Plunger
D4MC-5040**

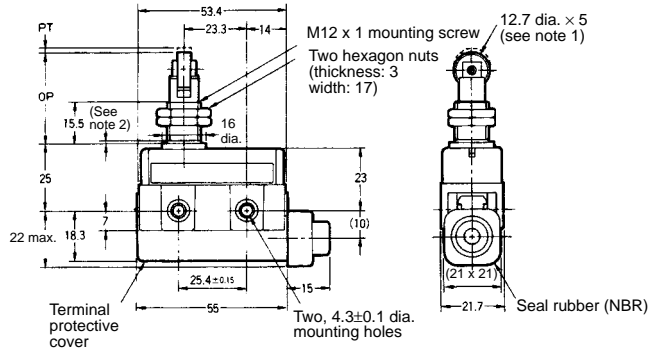

- Note:**
1. Stainless steel roller
 2. The length of the imperfect threads is 1.5 mm maximum.

**Short Hinge Lever
D4MC-1020**

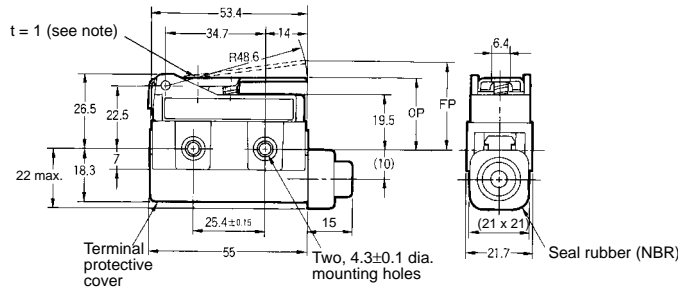

- Note:** Stainless steel lever

**Hinge Lever
D4MC-1000**

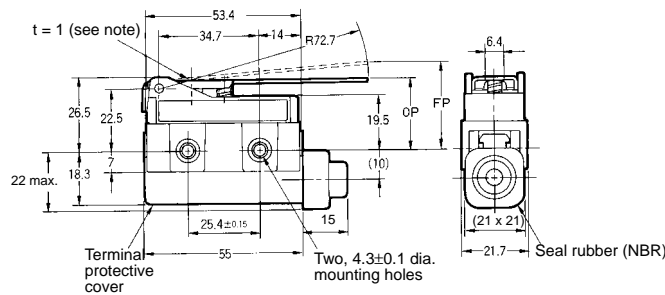

- Note:** Stainless steel lever

**Hinge Roller Lever
D4MC-2000**

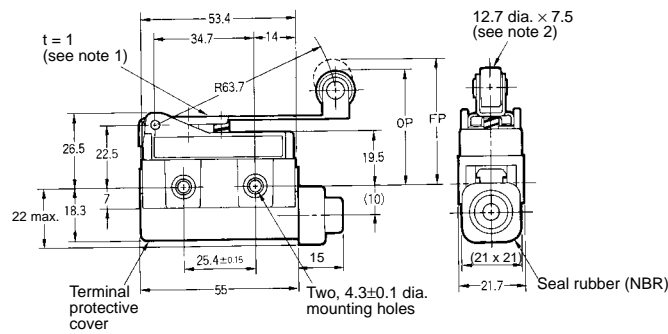

- Note:**
1. Stainless steel lever
 2. Plastic roller

**Short Hinge Roller Lever
D4MC-2020**

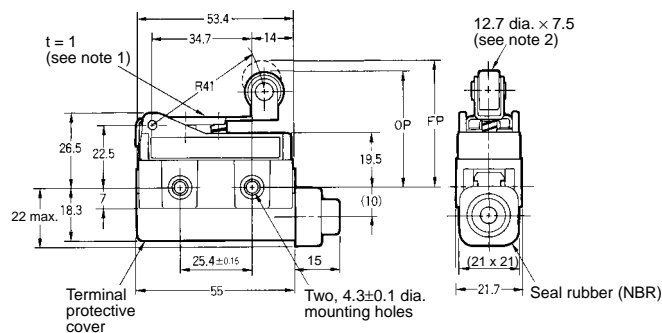

- Note:**
1. Stainless steel lever
 2. Plastic roller

**One-way Action Short Hinge Roller Lever
D4MC-3030**

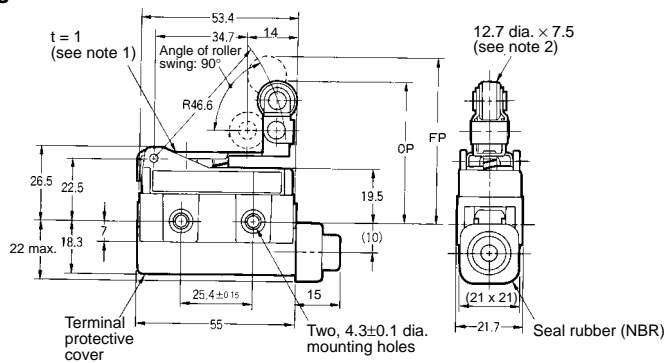

- Note:**
1. Stainless steel lever
 2. Plastic roller

Mounting Holes

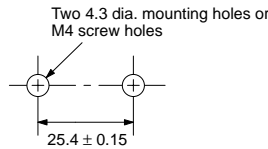

Molded Terminal Models

■ Molded Terminal Models

The molded terminal model is available with right-hand, left-hand and underside leads and is recommended for use where the Switch is exposed to dust, oil, or moisture.

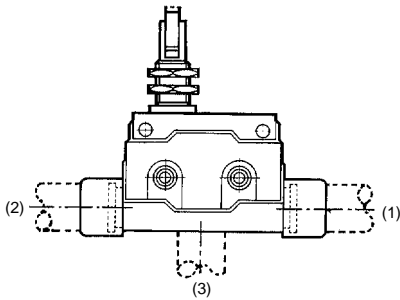

When placing your order for the Switch specify the required length of V.C.T. cable in addition to the model number of the Switch

Example:

Standard type: D4MC-5040
 Location of lead outlet: Underside
 Length of lead: 1 m (V.C.T. lead)
 When placing your order for the above Switch specify the model number as D4MC-5043 (V.C.T. 1 m)

Suffix by Location of Lead Outlet

Location of lead outlet	Model
	COM, NC, and NO
Right-hand	D4MC-□□□1
Left-hand	D4MC-□□□2
Underside	D4MC-□□□3

Leads Supplied

Leads	Nominal cross-sectional area	Finished outside diameter	Terminal connections	Standard length
V.C.T. (Vinyl cabtire cable)	1.25 mm ²	Triple conductor: 10.5 mm dia.	Black: COM White: NO Red: NC	1, 3, 5 m

■ Terminal Protective Cover

ZC55 Terminal Cover (ZC55-0002H):
 The following three parts are supplied as a set.

ZC Seal Rubber (SC-1404C)

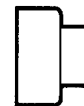
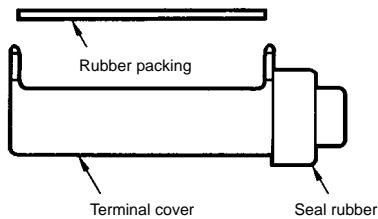

Precautions

■ Correct Use

Operating Method

Excessive dog angle, operating speed, or overtravel (OT) may damage the actuator. Check that OT has a sufficient margin. The actual OT should be rated OT x 0.7 to 1.

Handling

- Do not expose the Switch to water exceeding 60°C or use it in steam.
- Do not use the Switch in oil or water.
- An 8.5- to 10.5-dia. cable can be applied as seal rubber for the lead wire outlet. (Use two- or three-core cable of VCT1.25 mm².)
- When detaching the Terminal Protective Cover, insert a screwdriver and apply a force in the opening direction. Do not use excess force to remove the cover. Doing so may cause deformation in the fitting section and reduce the holding force.

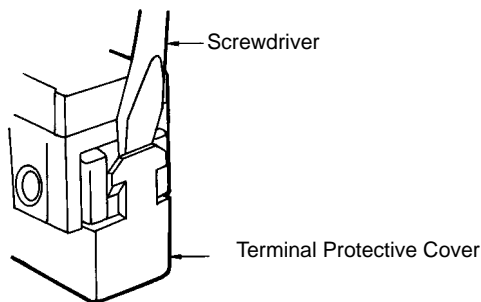

When mounting the Terminal Protective Cover to the case, align the cover on the case and then press the cover down to mount it firmly. If the cover is pressed down in an inclined position, rubber packing will deform and thus affect the sealing capability.

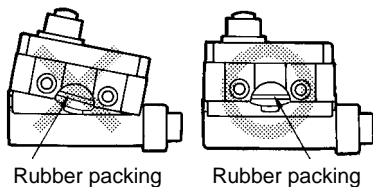

Mounting

When mounting the Switch with screws on a side surface, fasten the Switch with M4 screws and use washers, spring washers, etc., to ensure secure mounting.

Mounting Holes

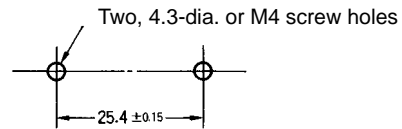

- When mounting the Panel Mount-type Switch (DCMC-5000, D4MC5020, or D4MC5040) with screws on a side surface, remove the hexagonal nuts from the actuator.
- When mounting the panel mount type on a panel, be careful not to tighten to an excessive torque. Tightening the screws to a torque exceeding 4.91 N • m will cause the plunger to fail.

Mounting Hole Dimensions

D4MC-5000

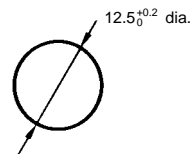

D4MC-5020, D4MC5040

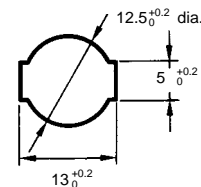

Correct Tightening Torque

A loose screw may cause malfunctions. Be sure to tighten each screw to the proper tightening torque as shown in the table.

No.	Type	Torque
1	Terminal screw	0.78 to 1.18 N • m
2	Panel mounting screw	2.94 to 4.92 N • m
3	Side mounting screw	1.18 to 1.47 N • m

ALL DIMENSIONS SHOWN ARE IN MILLIMETERS.

To convert millimeters into inches, multiply by 0.03937. To convert grams into ounces, multiply by 0.03527.