

# OMRON Model FZD-CBM/CBL

3D Camera Base Plate for Model FZD  
Visual Inspection System

## INSTRUCTION SHEET

Thank you for selecting OMRON product. This sheet primarily describes precautions required in installing and operating the product.

Before operating the product, read the sheet thoroughly to acquire sufficient knowledge of the product. For your convenience, keep the sheet at your disposal.

© OMRON Corporation 2007 All Rights Reserved.

### PRECAUTIONS ON SAFETY

#### ● Meaning of Signal Words

**WARNING** Indicates a potentially hazardous situation which, if not avoided, will result in minor or moderate injury, or may result in serious injury or death. Additionally there may be significant property damage.

**CAUTION** Indicates a potentially hazardous situation which, if not avoided, may result in minor or moderate injury or in property damage.

#### ● Alert Statements

##### WARNING

This product is not designed or rated for ensuring safety of persons. Do not use it for such purposes.

##### CAUTION

Read the Instruction sheet thoroughly and install the base plate correctly. Improper installation may cause the base plate to fall, resulting in personal injury or damage to equipment.

### PRECAUTIONS FOR SAFE USE

Be sure to respect following items for safety.

#### 1. Installation Site

Do not install the product in locations subjected to the following conditions

- Ambient temperature outside the rating
- Rapid temperature fluctuations (causing condensation)
- Relative humidity outside the range of 35 to 85%RH
- Presence of corrosive or flammable gases
- Presence of dust, salt, or metallic particles
- Direct vibration or shock
- Reflection of intense light (such as other laser beams or electric arc-welding machines)
- Direct sunlight or near heaters
- Water, oil, or chemical fumes or spray
- Strong magnetic or electric field
- Near high-voltage equipment or power equipment

#### 2. Handling the FZD-CBM/CBL

- Make sure to tighten all installation screws.
- Please follow the proper procedures when you install a camera in the model FZD-CBM/CBL.
- If you drop or break the body, please consult our any branch offices.

#### 3. Other

- Do not use this product for anything but measuring platform of 3D camera.
- Do not install any other cameras except the dedicated one.
- Dispose of FZD-CBM/CBL components as industrial waste.

### PRECAUTIONS FOR CORRECT USE

Please observe the following precautions to prevent failure to operate, malfunction, or undesirable effect.

- Please use the screws provided in kit.
- Do not use thinners, benzene, acetone, or kerosene to clean the model FZD-CBM /CBL.

### Specifications

Item	Model	FZD-CBM	FZD-CBL
Dimensions		500×50×20 mm	800×50×20 mm
		90×60×8 mm(Carrier)	
		64×46×10 mm(Camera turntable)	
		8Dia × 310 mm(Adjust bar)	
Base length for camera		100 to 400mm	330 to 700mm
Setting distance		300 to 1200mm	1000 to 2000mm
Storage temperature / humidity		-25 to 65°C / 35 to 85%RH (with no condensation)	
Material		Aluminum alloy, Stainless steel	
Weight		Main : Approx.1490g (Bench : Approx.970g)	Main : Approx.2080g (Bench : Approx.1560g)
		Adjust bar : Approx.130g	

### Character

This product is used as a 3D vision camera for FZD controller with two special cameras.

### Name of Part and Function

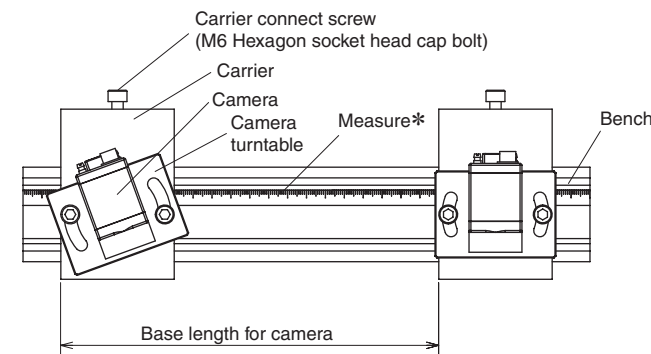

\*Measure is used for measuring the distance between two cameras.

### Mounting of Camera

① Set up the camera on the turntable.

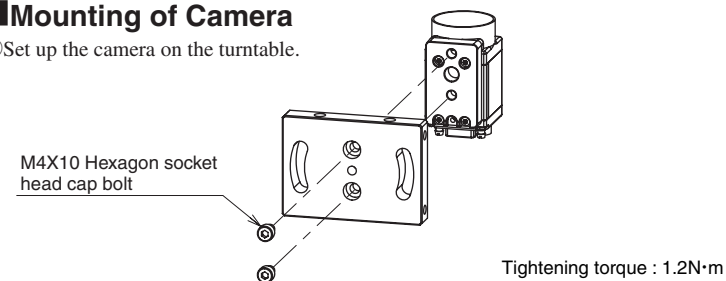

② Put the turntable with the camera on the carrier.

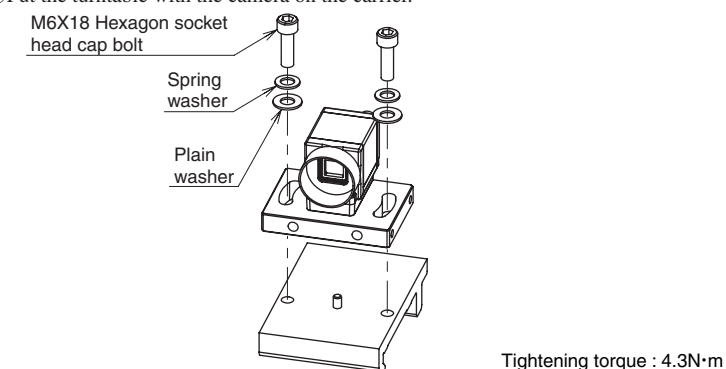

③ Put the bench on the equipment.

※ At this stage, the carrier must not be mounted on the bench.

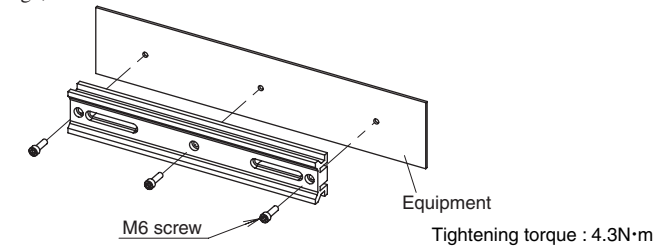

④ Set up the carrier on the bench, and then adjust the distance between two cameras and optical axis.

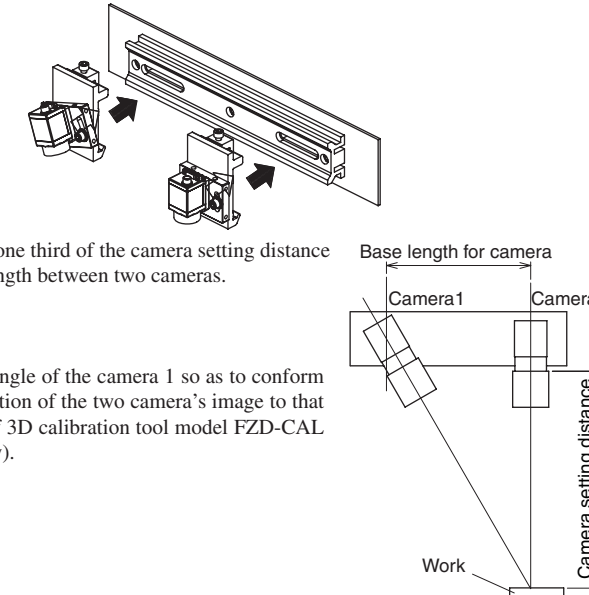

⑤ Take about one third of the camera setting distance for the base length between two cameras.

⑥ Adjust the angle of the camera 1 so as to conform the center position of the two camera's image to that of the target of 3D calibration tool model FZD-CAL (sell separately).

### How to use Adjust Bar

When you fine adjust the angle, put the adjust bar on the turntable and move the head of the bar lightly. Detach the bar after compliant adjustment.

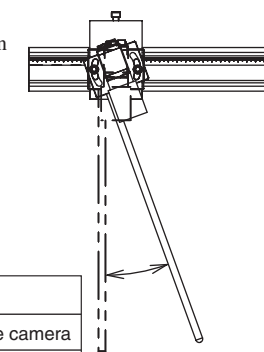

### Compliant Camera

Model	Specification
FZ-S	0.3 mega pixel digital monochrome camera
FZ-SC	0.3 mega pixel digital color camera
FZ-S2M	2 mega pixel digital monochrome camera
FZ-SC2M	2 mega pixel digital color camera

### Accessories

- Bench ··· 1
- Carrier, Camera turntable ··· 2
- Adjust bar ··· 1
- Carrier connect bolt
- M4X10 Hexagon socket head cap bolt ··· 4
- M6X18 Hexagon socket head cap bolt ··· 8
- Hexagon head wrench for M4, Hexagon head wrench for M6 ··· 1
- Instruction sheet (this sheet) ··· 1

### Dimensions

#### ● Camera base plate

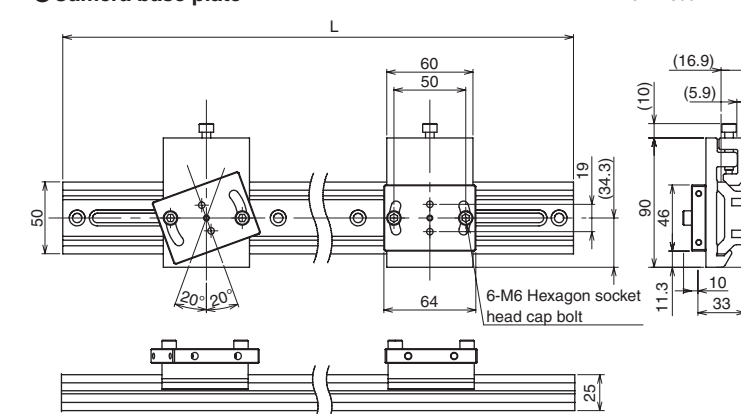

#### ● Bench (1) FZD-CBM

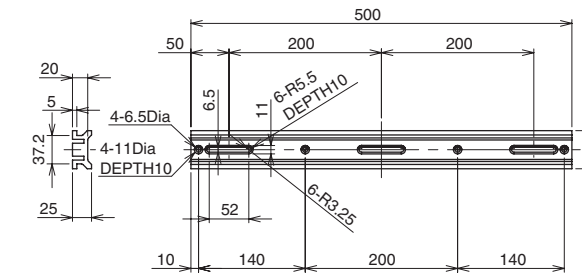

#### (2) FZD-CBL

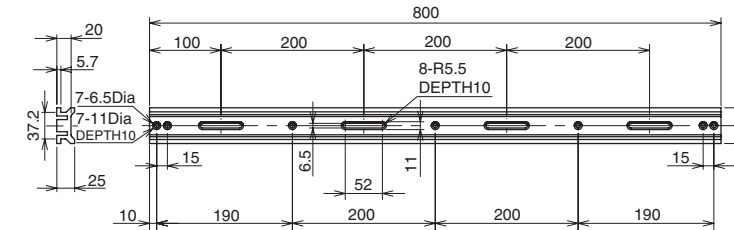

#### ● Adjust bar

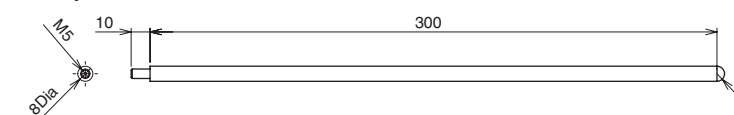

### Setting Dimensions

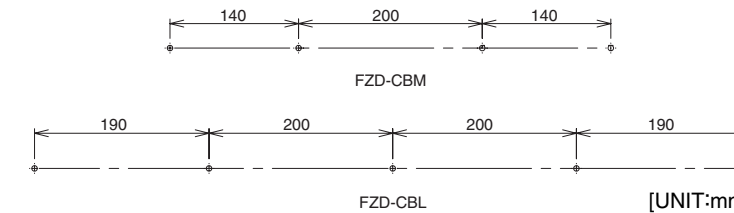

### Suitability for Use

THE PRODUCTS CONTAINED IN THIS SHEET ARE NOT SAFETY RATED. THEY ARE NOT DESIGNED OR RATED FOR ENSURING SAFETY OF PERSONS, AND SHOULD NOT BE RELIED UPON AS A SAFETY COMPONENT OR PROTECTIVE DEVICE FOR SUCH PURPOSES. Please refer to separate catalogs for OMRON's safety rated products.

OMRON shall not be responsible for conformity with any standards, codes, or regulations that apply to the combination of the products in the customer's application or use of the product.

Take all necessary steps to determine the suitability of the product for the systems, machines, and equipment with which it will be used. Know and observe all prohibitions of use applicable to this product.

NEVER USE THE PRODUCTS FOR AN APPLICATION INVOLVING SERIOUS RISK TO LIFE OR PROPERTY WITHOUT ENSURING THAT THE SYSTEM AS A WHOLE HAS BEEN DESIGNED TO ADDRESS THE RISKS, AND THAT THE OMRON PRODUCT IS PROPERLY RATED AND INSTALLED FOR THE INTENDED USE WITHIN THE OVERALL EQUIPMENT OR SYSTEM.

See also Product catalog for Warranty and Limitation of Liability.

#### ● EUROPE

OMRON EUROPE B.V. Sensor Business Unit  
Carl-Benz Str.4, D-71154 Nufringen Germany  
Phone:49-7032-811-0 Fax: 49-7032-811-199

#### ● NORTH AMERICA

OMRON ELECTRONICS LLC  
One Commerce Drive Schaumburg, IL 60173-5302 U.S.A  
Phone:1-847-843-7900 Telephone Consultation  
1-800-55-OMRON Fax : 1-847-843-7787

#### ● ASIA-PACIFIC

OMRON ASIA PACIFIC PTE LTD  
83 Clemenceau Avenue, #11-01 UE Square, Singapore 239920  
Phone : 65-6-835-3011 / Fax : 65-6-835-2711

**OMRON Corporation**