

Vision Sensor
F500

Network-compatible Sensor supports everything from high-precision detection to production and quality control



F500

Features

The F500 enables high-precision inspections and measurements in the factory and then goes further to support easy construction of a production and quality control system for quality traceability.

High-precision Sensing

1-million-pixel Digital Interface Camera
 Clear images are obtained by greatly reducing noise in high-resolution video signals.

User Customization for Even Simpler Operation
 Various applications are supported through features like flow menus that flexibly handle even complicated applications and macros that enable user programming.

A Wealth of Algorithms to Achieve High-precision Measurements
 High-precision measurements are achieved through original algorithms ideal for lowcontrast mark positioning, minute defect detection, and much more.

Applications Software

Build Flexible Applications
 The F500 provides OMRON's new menu system called Flow Menus, which enable flexible measurements through menu settings including multiple filtering operations and conditional branches based on measurement results.

Easier to Use, Easy to Program
 A Macro programming feature is provided to support measurement functions by enabling screen customization, I/O in-

terface changes, measurement condition changes, and much more. Macros can be easily programmed using a simple text editor.

Storage for Production and Quality Control

Store inspection and measurement data for safe keeping. Provide feedback to quality control data, or analyze the data to improve quality. The stored data can be used in many ways.

Large Storage Capacity
 Approximately 200 images minimum can be stored right in the Controller. Measurement images are stored without alteration for future use, such as repeating measurements to check measurement accuracy or attaching images to reports.

Remote Access and Operation across a Network



Easily achieve a production and quality control system using an IT environment that provides easy access to the production site and operating status.

Remote Access and Operation
 Data such as the operating status of the Vision Sensor and images resulting from inspections can be remotely accessed. Measurements, storage, and communications can be executed independently so that measurements will not stop even during random remote access.

Flexible User Customization for Any Purpose

Benefits of Increased Resolution

Doubling the horizontal and vertical resolutions increases total resolution by a factor of four, enabling clear images for small or complicated workpieces.

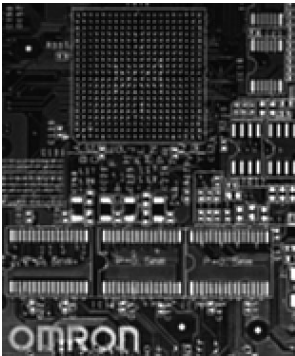

250,000 pixels (previous systems)

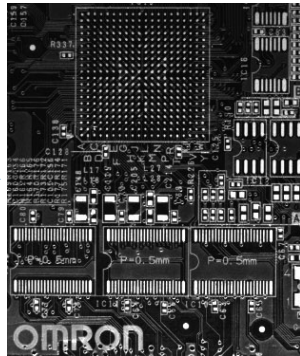

1 million pixels

1-million-pixel Camera with Digital Interface

The video signal noise that hurt measurement precision has been greatly reduced to enable inspections of minute foreign matter or damage as well as highprecision positioning.

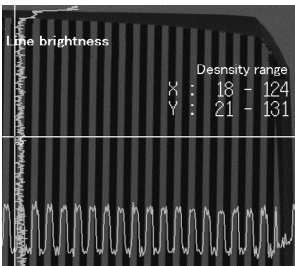

Line Brightness Image from an Analog Interface Camera

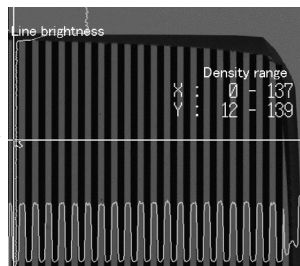

Line Brightness Image from a Digital Interface Camera

Partial Scan Function

Partial scans can be used to reduce the image reading time, which is often the bottleneck in measurement processing time.



Full Frame Reading

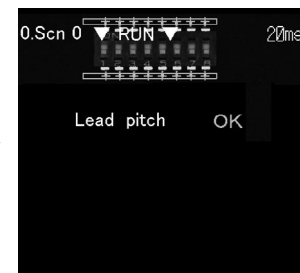

Partial Reading

| Number of Pixels read | Reading time |
|-----------------------|--------------|
| 1,024 x 1,024 pixels | 48.3 ms |
| 1,024 x 512 pixels | 27.6 ms |
| 1,024 x 256 pixels | 16.3 ms |
| 1,024 x 128 pixels | 10.7 ms |

Advanced Algorithms for High-precision Measurements

Positioning

ECM Searches

Edge code models are used for pattern searches. ECM searches are not easily affected by deformation and dirt, and can thus be very effective with low-contrast workpieces.

EC Positioning

Model registration is not required for EC positioning. Searching is possible with shape information, such as "circle," "rectangle," or "intersection." This achieves higher precision in measurements than conventional pattern matching methods.

Reference data: Repeatability is within 1/20 pixel (OMRON test data)

Appearance Inspections

EC Defect

Geometric information is used to measure minute defects or lowcontrast scratches in the measurement object at high precision. Stable detection is possible for applications like measuring deformation in O-rings.

EC Circle Count

Circles are searched for based on a circle of a specified size. Stable detection is possible without undue influence by deformation or dirt.

EC Circle Defect

Defects in circles, such as depressions and scorching in molded items, can be easily measured at high precision. The defect in the circle can be extracted even with a patterned background.

Reduced Work with Simple Operations

Zoom Function for 1-million-pixel Images

Zoom in to see detail clearly for easier setting and adjustment (display enlargement supported).

High-speed Serial USB Interface

A USB interface simplifies high-speed communications between the Vision Sensor and a computer. Communications can be used to handle measurement data, setting data, system data, image data, and more.

Networking to Access, Save, View and Edit Data

Batched Access and List Viewing of Logged Images¹

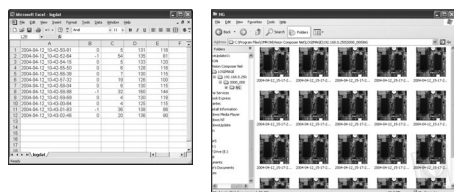

The data stored in the Controller can be displayed in lists.

[Access](#) [View](#)

Batched Access and List Viewing of Measurement Data¹

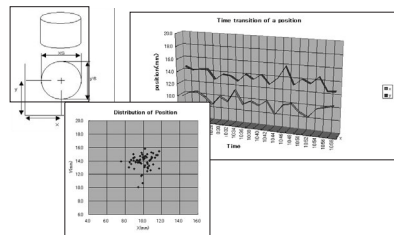

Links can be created to spreadsheet software to statistically process measurement results or display graphs. All measurement data can be saved for feedback to trend management or to monitor variations in measurement data.

[Access](#) [View](#)

Log Production and Quality Control Information¹

| | |
|------------------------------------|--------|
| Statistical data 02/12/11 11:25:45 | |
| Scanner | ScanID |
| Total # | 2000 |
| # of OK | 1980 |
| # of NG | 20 |
| OK ratio | 99.999 |
| NG ratio | 0.010 |

Macros can be used to total production quantities, production information such as fault rates, or NG products according to the type of inspection.

| No. | Light | Disp. Code | Number of pms | Character | Package | Time |
|-----|-------|------------|---------------|-----------|---------|----------|
| 1 | - | - | - | - | - | 18:39:30 |
| 2 | - | - | - | NG | - | 18:40:26 |
| 3 | - | - | - | - | - | 18:40:40 |
| 4 | - | - | - | - | - | 18:41:15 |
| 5 | - | - | - | NG | - | 18:41:50 |
| 6 | - | - | - | - | - | 18:42:25 |
| 7 | - | - | - | - | - | 18:43:00 |
| 8 | - | - | - | - | - | 18:43:35 |

[Access](#) [View](#)

Managing and Transferring Setting Data¹

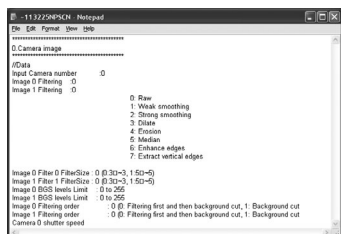

Files containing Vision Sensor setting data (such as scenes and system data) can be sent and received.

The software version of the Vision Sensor can also be easily upgraded.

[Access](#) [Save](#) [View](#)

Batch File Uploading¹

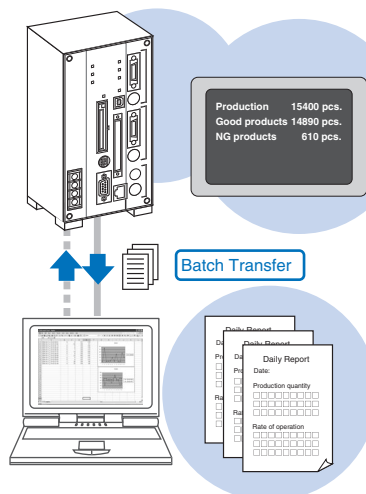

The data saved in the Controller can be transferred to a computer as a batch upload. This function is useful when determining judgement values for initial settings or to back up data. And because measurements and communications are executed independently, files can be uploaded without affecting the Vision Sensor's measurement operation.

Display and Edit Scene Data¹

Scene data set in Vision Sensors connected to the network can be viewed and edited. The scene data displayed on the computer can also be printed.

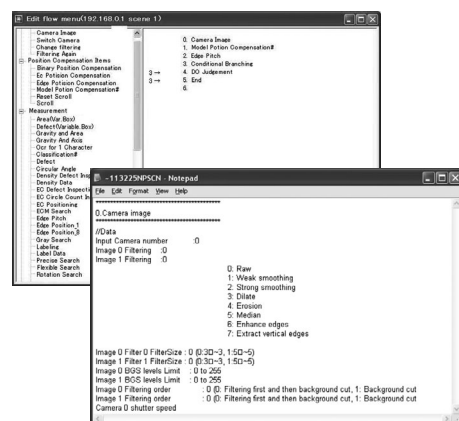

[View](#) [Save](#)

¹ Scheduled for release soon.

Remote Vision Sensor Operation in a Network Environment¹

Vision Composer Net¹

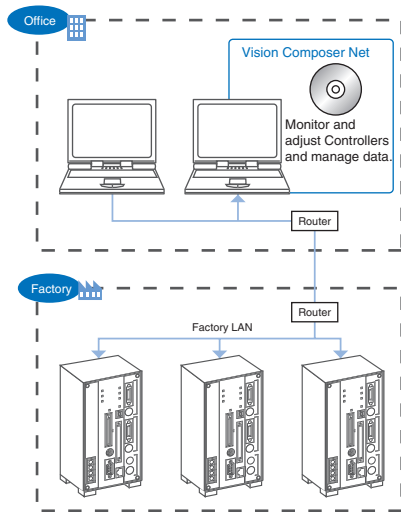

The Vision Composer Net software connects to OMRON Controllers to monitor and control operation, change settings, and perform other tasks.

Controllers can be connected across networks to monitor and adjust Controllers in the factory from an office.

Live Monitoring Function

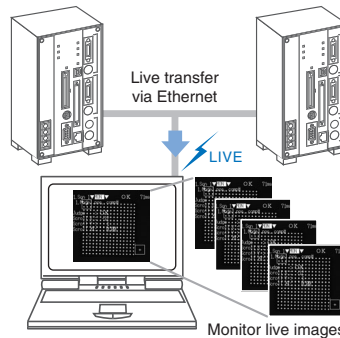

Vision Sensor images can be displayed in realtime on the computer via Ethernet. (See note 1.)

Live inspection images can also be monitored remotely. (See note 2.) And what's more, the images from several Controllers connected via the network can be monitored simultaneously on the computer screen.

Note 1: The transfer speed of live images depends on the network environment.

Note 2: Remote monitoring is not possible through a firewall.

Download Setup Function¹

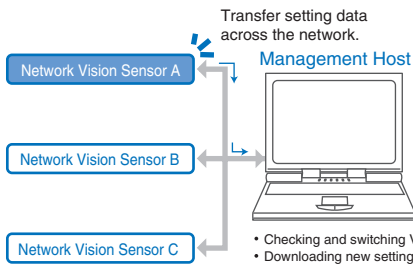

Vision Sensors in different production lines can be easily set up.

Downloading is also useful when changing products or using new programs.

- Checking and switching Vision Sensor settings
- Downloading new settings, and more

Remote Operations

Vision Sensor measurements can be started and stopped and scene data settings can be specified from a remote computer.

All operations that were previously possible from the Console can be performed remotely from a computer.

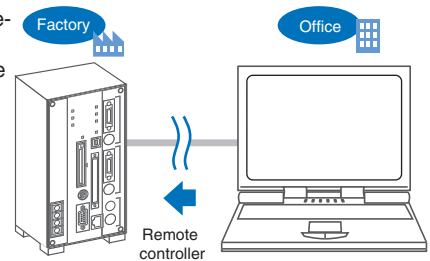

¹ Scheduled for release soon.

Applications

Connector and IC Lead Inspections

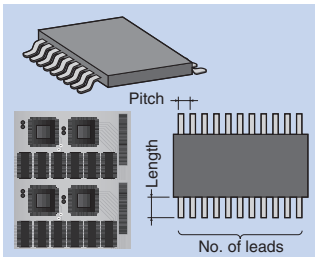

Sensing

High-resolution inspection over a wide field of view is enabled by using a 1-million-pixel high-resolution camera.

And with **macro** functions, the statistics on lead pitch data and linear approximations of the lead ends are easily performed.

Storage & Network

Combining **networking** enables changing inspection devices, managing master data, and uploading statistical data files with macros.

BGA Inspections

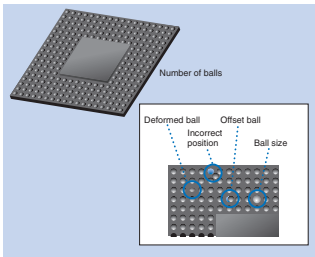

Sensing

High-resolution inspection over a wide field of view is also enabled by using a 1-million-pixel high-resolution camera with BGA inspection software. Variant BGA processing is also possible.

Storage & Network

Quality control data can be used effectively by storing inspection images in relation to lot numbers. Managing all of the product data on the host computer makes frequent changes to settings much smoother.

Positioning Liquid Crystal Boards

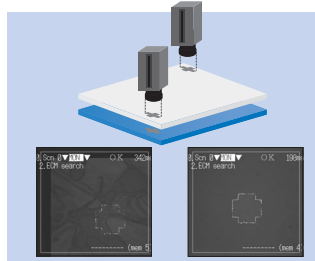

Sensing

EC processing, based on an original algorithm from OMRON, enables position inspections of low-contrast alignment marks. And using a Digital Interface Camera enables stable processing.

Macros can also be used to easily achieve original calibration methods, inspection data calculations, and much more.

Storage & Network

Managing productivity is also possible by saving and reviewing inspection images, detection data, and position compensation data.

Printing Defects



Sensing

Using a 1-million-pixel high-resolution camera provides high-precision inspections over a wide field of view.

Using **macros** enables saving images and inspection data classified by the type of fault.

Storage & Network

For initial system startup, data to determine judgement values and to troubleshoot problems can be accessed from a remote computer, reducing costs to a minimum.

Molded Product Defect Inspections

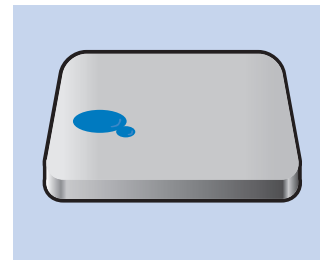

Sensing

Misshapen products, as well as contamination and scorching around molded products, can be detected. Setting is as easy as specifying the circle size to detect (i.e., the size of the defects) on limit samples displayed on the monitor.

With **macros**, statistics on good products, NG products, and fault rates for the inspections performed each day can be calculated and logged in a Memory Card.

Ceramic Board Defect Inspection

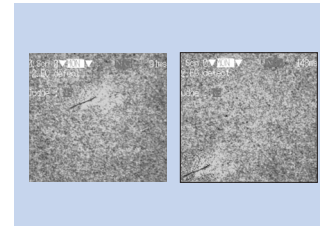

Sensing

Inspect for cracks on the surface of ceramic boards. Even if uneven lighting or rough surfaces show in the images, linear aspects can be consistently detected.

Using the **flow menu** enables conversion to more stable inspection by repeatedly filtering images.



Inspecting Electrolytic Capacitor Dimensions

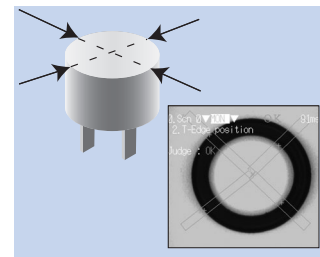

Sensing

The diameter of round workpieces can be measured at multiple points to determine if they are round or not.

With **macros**, deviations in inspection values can be stored in memory and statistics, such as minimum values, maximum values, and standard deviations, can be calculated.

Chip Capacitor Electrode Defect Inspection

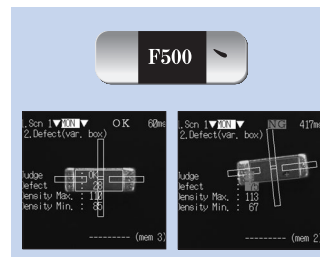

Sensing

Even if the size of the inspection object changes, the size of the inspection area adjusts to the external size to enable measurement. Misshapen products and contamination and scorching around products can be detected.

With **macros**, production statistics (e.g., number of good products, number of NG products, and fault rates) can be calculated and monitored onscreen.

List of Processing Items

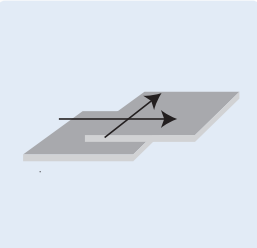
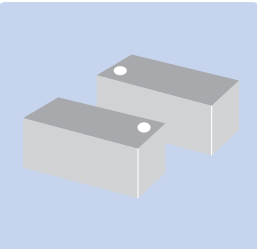
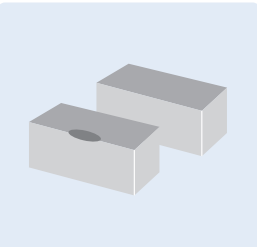
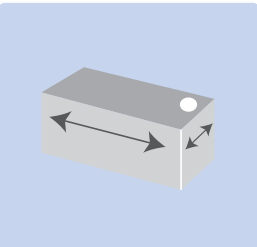
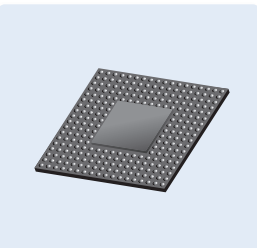

| Processing Items | Binary Processing | Gray-scale Processing | EC Processing |
|--|--|---|--|
| <p>Positioning</p>  | <p>Gravity and Axis</p> | <p>Gray Search (x-y: Pixel Level) Precise Search (x-y: Subpixel Level) Rotation Search (x-y-θ: Subpixel Level) Circular Angle</p> | <p>ECM Search EC Positioning</p> |
| <p>Presence and Direction Inspections</p>  | <p>Gravity and Area Binary Defect Labeling Label Data (counting possible)</p> | <p>Density Data (Average and Deviation) Gray Search (x-y: Pixel Level)</p> | <p>EC Circle Count</p> |
| <p>Appearance (Defect) Inspections</p>  | <p>Area (Var. Box)</p> | <p>Density Defect # Defect Defect (Var. Box) Fine Matching Flexible Search</p> | <p>EC Circle Defect EC Defect</p> |
| <p>Dimensions</p>  | | <p>Edge Position_1 Edge Position_8 (Number of areas drawn differs.) Edge Width (Width between edges measured.) T-Edge Position</p> | |
| <p>Applications Packages</p>  | | <p>BGA</p> | |

The F500-UM Applications Software is used both with the F210 and F250.
 Many other measurement functions are also supported by this software. For details, go to <http://www.fa.omron.co.jp/sensing/>

Complete Image Processing Items

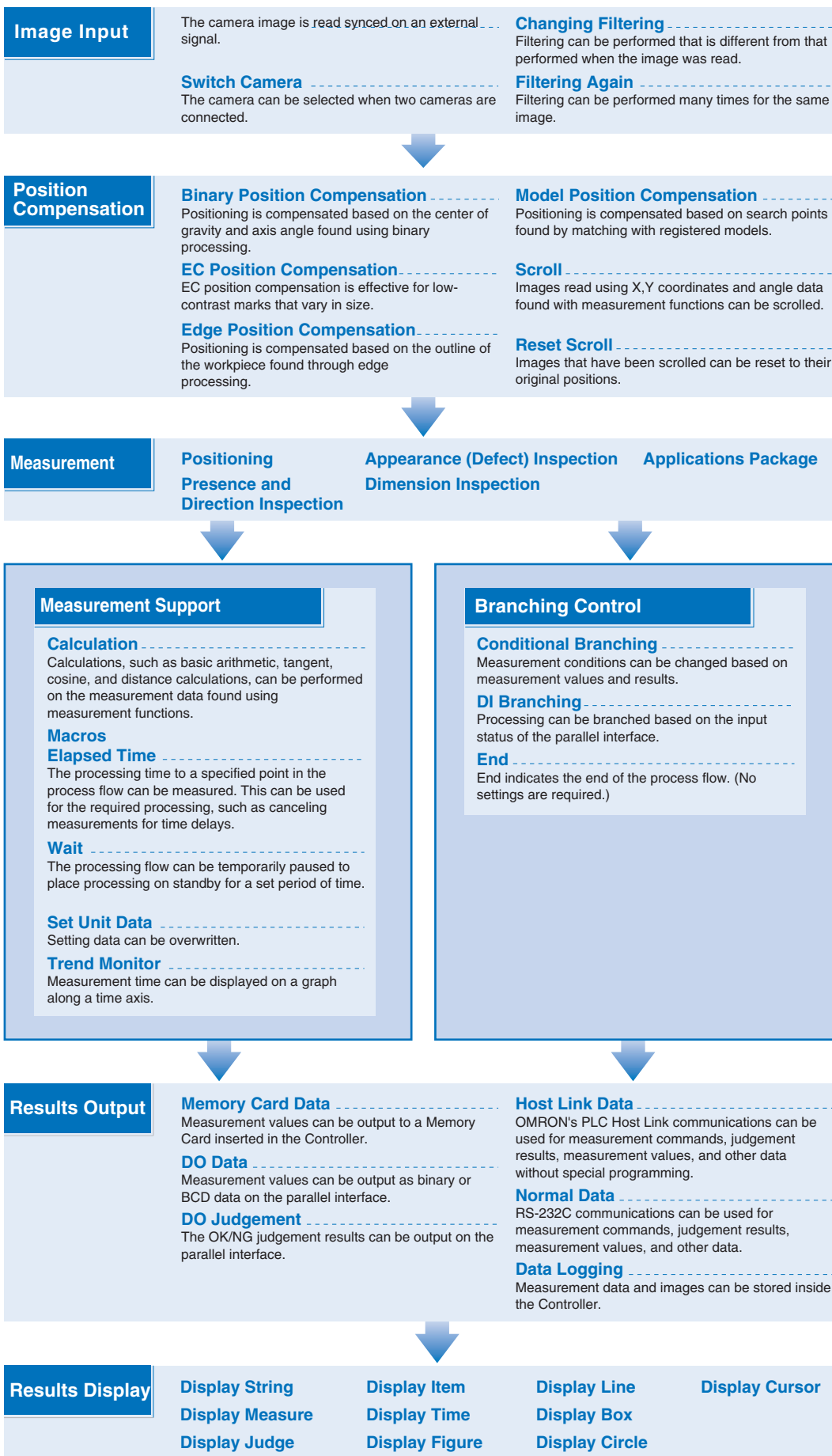

F500

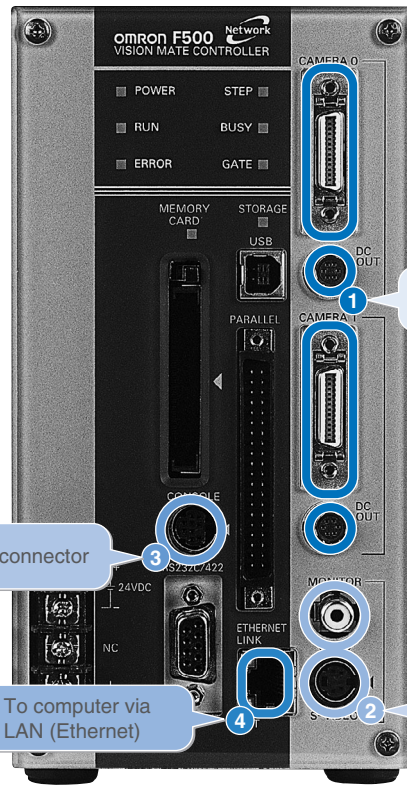

Network-compatible Vision Sensor
F500-C10-ETN/F500-C15-ETN

1

Camera Cable
F500-VS 2M

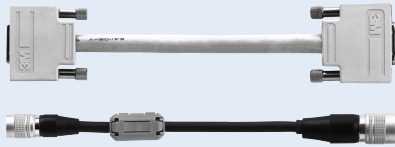

1-million-pixel Camera with Digital Interface
F500-S1



2

10.4-inch LCD Monitor
F500-M10L



Optical Chart

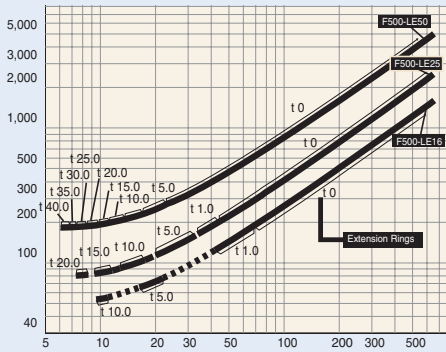

High-resolution Lens



3

Consoles
F150-KP F160-KP



4

PC Support Software
F500-CD2E Vision Composer Net



Memory Cards
F160-N64S (S) QM300-N128S
F160-N256S

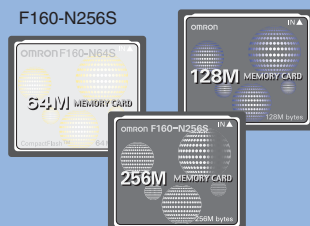

Applications Software
F500-UM2FE/UM2ME

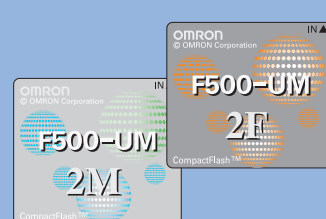

* Scheduled for release soon.

Specifications

F500-C10-ETN / F500-C15-ETN

| | |
|-----------------------------------|---|
| Connected Camera | F500-S1 |
| No. of connectable Cameras | 2 |
| Processing resolution | 1,024 (H) x 1,024 (V) |
| No. of scenes | 32 (Can be increased using Memory Cards) |
| Image memory function | 35 images max |
| Storage | 256 MB non-volatile memory |
| Operation and setting | Measurement items installed using Applications Software. Menu operations used to combine measurement items. Vision Composer Net can be used for operation and settings. |
| Menu language | Japanese or English (switchable) |
| Serial communications | USB series B: 1 channel RS-232C/422: 1 channel |
| Network communications | Ethernet 100Base-TX/10Base-T |
| Parallel I/O | 11 inputs, 22 outputs |
| Monitor Interface | Composite video output: 1 channel S-VIDEO output: 1 channel |
| Memory Card interface | Compact Flash card slot, 1 channel |
| Power supply voltage | 20.4 to 26.4 V DC |
| Current consumption | 2.1 A max. (with two F500-S1 Cameras connected) |
| Ambient temperature | Operating: 0 to 55°C Storage: -25 to 65°C with no icing or condensation |
| Ambient humidity | Operating / Storage: 35% to 85% with no condensation |
| Dimensions | 100 x 198 x 134 mm (W x H x D) (without connectors and other protrusions) |
| Weight | Approx. 1.6 kg (Controller only) |
| Accessories | Ferrite core for console (1), Setup Manual |

F500-S1

| | |
|--------------------------------|---|
| Picture elements | 2/3-inch CCD |
| Pixel size | 6.45 μm (H) x 6.45 μm (W) |
| Shutter | Electronic shutter, 10 shutter speeds (1/24 to 1/10,000 s), changed via menu |
| Partial function | Four settings |
| Communication interface | Conforms to Camera Link |
| Ambient temperature | Operating: 0 to 50°C Storage: -25 to 60°C with no icing or condensation |
| Ambient humidity | Operating / Storage: 30% to 85% with no condensation |
| Dimensions | 50 x 40 x 90 mm (W x H x D) (without connectors and other protrusions) |
| Weight | Approx. 270 g |
| Accessories | Instruction Manual |

System Requirements for F500-CD2E Vision Composer Net

| | | |
|----------------------|---|--------------------------------|
| CPU | Pentium III 600 MHz min. (Pentium III 1 GHz min. recommended) | |
| OS | Windows 2000 Professional, Service Pack 3 or higher Windows XP Home Edition, Service Pack 1 or higher Windows XP Professional, Service Pack 1 or higher | |
| Memory | 192 MB min. (256 MB min. recommended) | |
| Hard disk | 200 MB min. available space | |
| Monitor | Resolution: 1,024 x 768 min. Display colors: High Color (16-bit) min. (True Color (32-bit) min. recommended) | |
| Network | 10BaseT-compliant network (100Base-TX recommended) | |
| Vision Sensor | Controller | F500-C10-ETN/F500-C15-ETN |
| | Application Software | F500-UM Version 2.00 or higher |

Dimensions

• Console
F160-KP (Unit: mm)

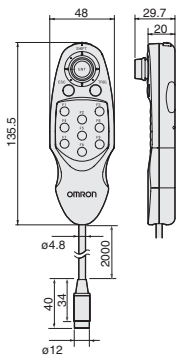

• Controller
F500-C10-ETN
F500-C15-ETN (Unit: mm)

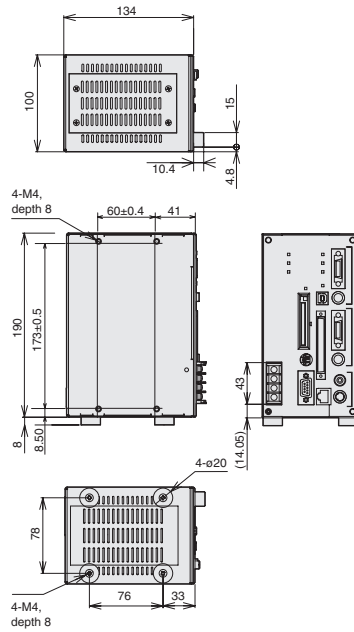

• Monitor
F500-M10L (Unit: mm)

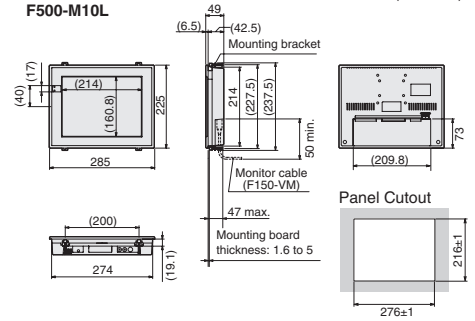

• Camera
F500-S1 (Unit: mm)

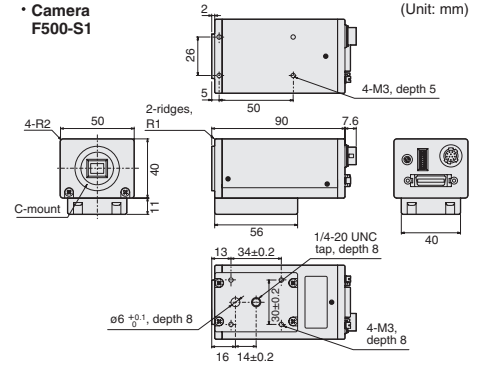

ALL DIMENSIONS SHOWN ARE IN MILLIMETERS.
To convert millimeters into inches, multiply by 0.03937. To convert grams into ounces, multiply by 0.03527.