

F250 Vision Sensor

F250-C50/C55

Manual 1: Setup Manual

Produced September 2001

Notice:

OMRON products are manufactured for use according to proper procedures by a qualified operator and only for the purposes described in this manual.

The following conventions are used to indicate and classify precautions in this manual. Always heed the information provided with them. Failure to heed precautions can result in injury to people or damage to property.

 **DANGER** Indicates an imminently hazardous situation which, if not avoided, will result in death or serious injury.

 **WARNING** Indicates a potentially hazardous situation which, if not avoided, could result in death or serious injury.

 **Caution** Indicates a potentially hazardous situation which, if not avoided, may result in minor or moderate injury, or property damage.

OMRON Product References

All OMRON products are capitalized in this manual. The word "Unit" is also capitalized when it refers to an OMRON product, regardless of whether or not it appears in the proper name of the product.

Visual Aids

The following headings appear in the left column of the manual to help you locate different types of information.

Note	Indicates information of particular interest for efficient and convenient operation of the product.
1,2,3...	1. Indicates lists of one sort or another, such as procedures, checklists, etc.
Precaution	Indicates information required to take full advantage of the functions and performance of the product. Incorrect application methods may result in the loss of damage or damage to the product. Read and follow all precautionary information.
CHECK	Indicates points that are important in using product functions or in application procedures.
TwoCamera	Indicates information required when using a 2-camera system.
SeeAlso	Indicates where to find related information.
HELP	Indicates information helpful in operation, such as the definition of terms.

© OMRON, 2001

All rights reserved. No part of this publication may be reproduced, stored in a retrieval system, or transmitted, in any form, or by any means, mechanical, electronic, photocopying, recording, or otherwise, without the prior written permission of OMRON.

No patent liability is assumed with respect to the use of the information contained herein. Moreover, because OMRON is constantly striving to improve its high-quality products, the information contained in this manual is subject to change without notice. Every precaution has been taken in the preparation of this manual. Nevertheless, OMRON assumes no responsibility for errors or omissions. Neither is any liability assumed for damages resulting from the use of the information contained in this publication.

TABLE OF CONTENTS

PRECAUTIONS	xi
1 Special or Critical Applications	xii
2 General Safety Precautions	xii
3 Regulations and Standards	xiii
SECTION 1	
Introduction	1
1-1 Installation Precautions	2
1-2 Confirming Package Contents	6
1-3 Product Availability	6
SECTION 2	
Special Features, Installation, and Connections	7
2-1 Special Features	8
2-2 Basic System Configuration	12
2-3 Component Names and Functions	14
2-4 Mounting the Controller	15
2-5 Connecting Peripheral Devices	17
2-6 Power Supply and Ground	19
SECTION 3	
Lenses, Lighting, and Memory Cards	21
3-1 CCTV Lenses	22
3-2 Lighting	25
3-3 Memory Cards	27
SECTION 4	
Connecting External Devices	29
4-1 Connecting through the Parallel Interface	30
4-2 Connecting through the Serial Interface	37
SECTION 5	
Troubleshooting and Maintenance	43
5-1 Troubleshooting	44
5-2 Maintenance	46
5-3 Regular Inspections	49
5-4 Specifications	50
5-5 F200/F300 Camera Parameters	68
5-6 Connecting a Strobe Device	70
Index	71
Revision History	73

About this Manual:

This manual describes the hardware for the F250 Vision Sensor and how to install the components, and it includes the sections described below. This is one of two manuals used to operate the F250. Refer to the following table for the contents of each manual.

Manual	Contents	Cat. No.
1: Setup Manual	Provides information on system hardware and installation. Be sure to read this manual first.	SCHB-736A
2: Operation Manual (on CD-ROM)	The Operation Manual CD-ROM is packed with the F250-UME Application Software. This manual explains basic operations such as installing the Application Software, setting up inspection processes, and communicating with external devices.	Z153-E1-01

Please read the above manuals carefully and be sure you understand the information provided before attempting to install or operate the F250.

Section 1 *Introduction* describes the precautions that must be taken when installing and operating the F250 Vision Sensor.

Section 2 *Special Features, Installation, and Connections* shows a basic F250 system configuration and explains how to install the F250 and connect it to a power supply and peripheral devices.

Section 3 *Lenses, Lighting, and Memory Cards* describes how to select and use these components most effectively.

Section 4 *Connecting External Devices* describes how to connect external devices through a parallel interface (the parallel connectors) or serial interface (the RS-232C/RS-422 connector or Ethernet connector).

Section 5 *Troubleshooting and Maintenance* provides tables to help identify and correct hardware errors that may occur with the F250 as well as information on maintenance and periodic inspections.



WARNING Failure to read and understand the information provided in this manual may result in personal injury or death, damage to the product, or product failure. Please read each section in its entirety and be sure you understand the information provided in the section and related sections before attempting any of the procedures or operations given.

PRECAUTIONS

This section provides general precautions for using the F250 Vision Sensor.

The information contained in this section is important for the safe and reliable application of the F250 Vision Sensor. You must read this section and understand the information contained before attempting to set up or operate an F250 Vision Sensor.

1	Special or Critical Applications.....	xii
2	General Safety Precautions	xii
3	Regulations and Standards.....	xiii

1 Special or Critical Applications

When the F250 will be used in one of the conditions or applications listed below, allow extra safety margins in ratings and functions, add extra safety features such as fail-safe systems, and consult your OMRON representative.

- Operating conditions or environments which are not described in the manual
- Nuclear power control systems, railroad systems, aviation systems, vehicles, combustion systems, medical equipment, amusement equipment, or safety equipment
- Other systems, machines, and equipment that may have a serious influence on lives and property and require extra safety features

2 General Safety Precautions

Battery Precautions

⚠ WARNING Do not disassemble the F250, apply pressure to the F250 that would deform its shape, or incinerate the F250. A lithium battery is built into the F250 and it may combust, explode, or burn if not treated properly.

⚠ WARNING Do not short circuit, attempt to charge, disassemble, apply pressure that would deform, or incinerate the lithium battery. The lithium battery may start a fire, explode, or burn if not treated properly.

Installation Environment Precautions

⚠ Caution Do not use the F250 in environments with flammable or explosive gases.

⚠ Caution Install the F250 away from high-voltage devices and moving machinery to allow safe access during operation and maintenance.

⚠ Caution Install the F250 so that air can flow freely through its cooling vents. If the vents are blocked, heat will build up in the Controller and may cause burns.

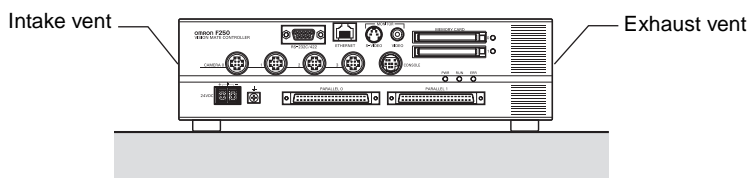

⚠ Caution Be sure to securely tighten the screws when mounting the F250.

Power Supply and Wiring Precautions



⚠ Caution Use the F250 with the power supply voltages specified in this manual.

⚠ Caution Use the wire and crimp terminals of the proper sizes as specified in this manual. Do not connect the power supply wires by just twisting stranded wire and connecting directly to the terminals.

⚠ Caution Use a DC power supply with countermeasures against high-voltage spikes (safe extra low-voltage circuits on the secondary side).

- Note**
1. Keep the power supply wires as short as possible (Max. 10 m).
 2. Ground the F250's ground terminal to less than 100 Ω .
 3. Use a grounding point as close as possible to the F250 and keep the ground line as short as possible.
 4. Wire the F250 to the ground with a separate ground wire. To avoid grounding problems, do not share the ground wiring with any other devices or ground the F250 to the building's steel framing/plumbing.

Other Precautions

-  **Caution** Do not attempt to dismantle, repair, or modify the F250.
-  **Caution** Do not touch fluorescent or halogen lights while the power is ON or immediately after the power is turned OFF. These lights get very hot and can cause burns.
-  **Caution** If you suspect an error or malfunction, stop using the F250 immediately, turn OFF the power supply, and consult your OMRON representative.

Note Dispose of the F250 as industrial waste.

3 Regulations and Standards

The F250 complies with the EC Directive and EN standard below.

1. EC Directives
EMC Directive: No. 89/336/EEC
2. EN Standards (European Standards)
EN 61326: 1997/Annex A+A1: 1998 (EMI: Class A)

SECTION 1

Introduction

This section describes the precautions that must be taken when installing and operating the F250 Vision Sensor.

1-1	Installation Precautions	2
1-1-1	Controller Installation.	2
1-1-2	Component Installation and Handling	4
1-2	Confirming Package Contents	6
1-3	Product Availability	6

1-1 Installation Precautions

The F250 is highly reliable and resistant to most environmental factors. The following guidelines, however, must be followed to ensure reliability and optimum use of the F250.

⚠ Caution Read the *Precautions* section before proceeding with installation or operation.

1-1-1 Controller Installation

Installation Site

Do not install the F250 in locations subject to the following conditions:

- 1,2,3...**
1. Ambient temperatures outside of the 0 to 50°C (32 to 122°F) range
 2. Rapid temperature fluctuations (likely to cause condensation)
 3. Relative humidities outside of the 35% to 85% range
 4. Presence of corrosive or flammable gases
 5. Presence of dust, salt, or iron particles
 6. Direct vibration or shock
 7. Direct sunlight
 8. Water, oil, or chemical fumes or spray

Orientation of Controller

To improve heat dissipation, install the Controller in the following orientation only. For proper air flow, provide at least 20 mm of clearance above the Controller and at least 50 mm of clearance on both sides.

- Horizontal Installation

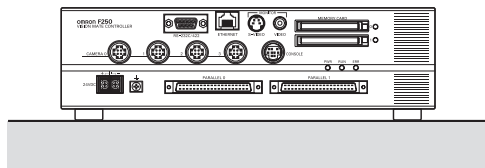

Do not install the Controller upside down as shown in the following diagram.

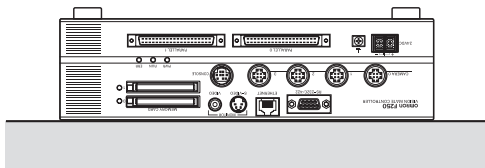

• Vertical Installation

The Controller can be installed vertically with the air intake at the bottom and exhaust at the top. For proper air flow, provide at least 20 mm of clearance at the top of the Controller and at least 50 mm of clearance on both sides (the intake and exhaust sides).

CORRECT



Exhaust

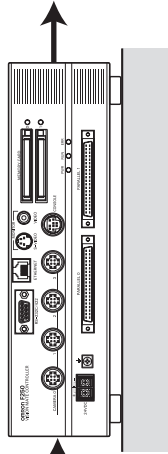

Intake

INCORRECT



Intake

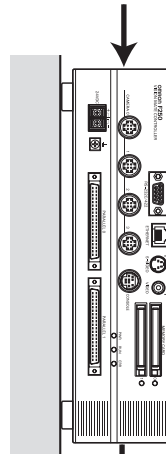

Exhaust

Ambient Temperature

1,2,3...

1. For proper air flow, maintain a minimum clearance of 20 mm at the top of the F250 and at least 50 mm of clearance at the sides where the cooling air intake and exhaust are located.
2. Do not install the F250 immediately above significant heat sources, such as heaters, transformers, or large-capacity resistors.
3. Do not let the ambient operating temperature exceed 50°C (122°F).
4. Provide a forced-air fan cooling or air conditioning if the ambient temperature is near 50°C (122°F) so that the ambient temperature never exceeds 50°C (122°F).

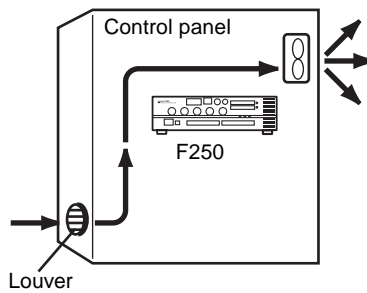

Noise Resistance

Use the following measures to help increase noise resistance.

- 1,2,3...**
1. Do not install the F250 in a cabinet containing high-voltage equipment.
 2. Do not install the F250 within 200 mm of power cables.

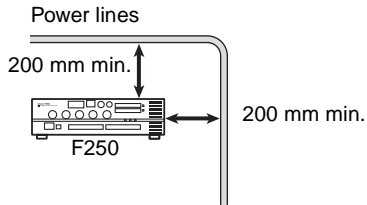
**1-1-2 Component Installation and Handling****OMRON Components**

Use a Camera, Camera Cable, and Console designed specifically for the F250.

Connecting Cables

Always turn OFF the F250's power before connecting or disconnecting a camera or cable.

Handling the Camera

The Camera's case is connected to the 0V line in the internal circuits. Observe the following precautions to prevent noise interference.

- 1,2,3...**
1. Do not ground the Camera.
 2. Do not remove the base attached to the Camera.
 3. Do not remove the ferrite core attached to the F150-VS or F160-VSR□□ Camera Cable.

Securing the Video Monitor (When Using the Recommended F150-M09)

Observe the following precautions to prevent noise interference, because the video monitor case is connected to the 0V line in the internal circuits.

- 1,2,3...**
1. Do not ground the video monitor.
 2. Do not ground the metallic part of the connector.
 3. Secure the video monitor with plastic screws if it is being mounted to a metallic surface.

Touching Signal Lines

To prevent damage from static electricity, use a wrist strap or another device for preventing electrostatic discharges when touching terminals or signal lines in connectors.

Handling the Memory Card

- To prevent damage from static electricity, do not touch the Memory Card directly while it is installed in the F250.
- To remove a Memory Card, turn OFF the power supply to the Card (using the menu command) or turn OFF the F250. Press the eject button to eject the Card. The Memory Card or the F250 itself may be damaged if a Memory Card is removed while power is being supplied.

Note F250-UME Precautions

It will not be possible to start the Setup Menu if you change the contents of the Memory Card after installing it in a personal computer or other device. Never

change the contents of the Card with operations such as the following:

- Changing file names
- Moving or deleting files
- Overwriting data
- Formatting

Turning OFF the Power

Do not turn OFF the power while a message is being displayed indicating that processing is being performed. Data in memory will be corrupted, and the F250 may not operate correctly the next time it is started.

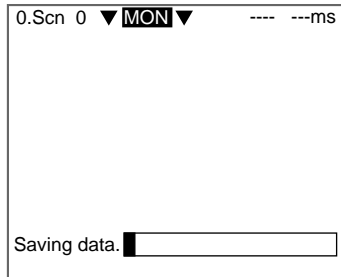

Using the RESET Signal

Do not use the RESET input immediately after power is turned ON. When using the RESET input to synchronize startup timing, wait at least 1 second after the F250's power supply is turned ON before turning ON the RESET signal.

Replacing the Battery

The F250 is equipped with a battery that backs up the clock. When the battery is low, the message "BATTERY LOW" will be displayed on the monitor at startup. The battery must be replaced when this message is displayed. Return the F250 to your OMRON dealer for service. (The battery is not user-serviceable.)

The battery will last approximately 7 years.

1-2 Confirming Package Contents

Check the contents of the package as soon as you receive the F250. It is extremely rare for components to be missing, but contact the nearest OMRON representative if any of the following items are missing.

- 1,2,3...** 1. F250 Vision Mate Controller Qty.: 1

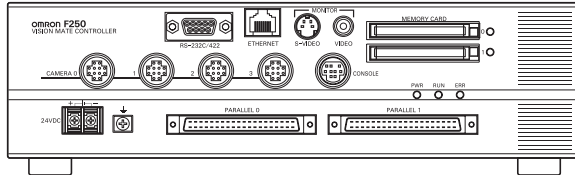

2. Ferrite core for F150-KP Console or F160-KP Console Qty: 1
 Ferrite core for F150-VM Monitor Cable Qty: 1

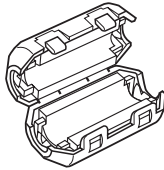

3. Setup Manual (this manual) Qty.: 1

CHECK The *F250 Vision Sensor Manual 2: Operation Manual* (on CD-ROM) is packed with the F250-UME Application Software.

1-3 Product Availability

Some of the products listed may not be available in some countries. Please contact your nearest OMRON sales office by referring to the addresses provided at the back of this manual.

SECTION 2

Special Features, Installation, and Connections

This section describes some of the special features of the F250, shows a basic F250 system configuration, and explains how to install and wire the F250.

2-1	Special Features	8
2-1-1	Problems Solved with a New Algorithm	9
2-1-2	Simple and Flexible Inspection Settings	11
2-1-3	Smooth Switching between Processes	11
2-2	Basic System Configuration	12
2-3	Component Names and Functions	14
2-4	Mounting the Controller	15
2-4-1	Horizontal Mounting	15
2-4-2	Vertical Mounting	16
2-5	Connecting Peripheral Devices	17
2-5-1	Connecting a Console	17
2-5-2	Connecting a Monitor	17
2-5-3	Connecting a Camera	17
2-6	Power Supply and Ground	19
2-6-1	Crimp Terminals and Cables	19
2-6-2	Ground (Earth) Wiring	19
2-6-3	Wiring the Power Supply	20

2-1 Special Features

The F250 Vision Sensor uses a camera instead of the human eye to process images and inspect products. Visual inspections can be automated to perform complicated inspections quickly and accurately.

There were problematic cases in which Vision Sensors could not detect differences that could be detected by the human eye. The F250 is a high-performance Vision Sensor that solves many of these problems.

2-1-1 Problems Solved with a New Algorithm

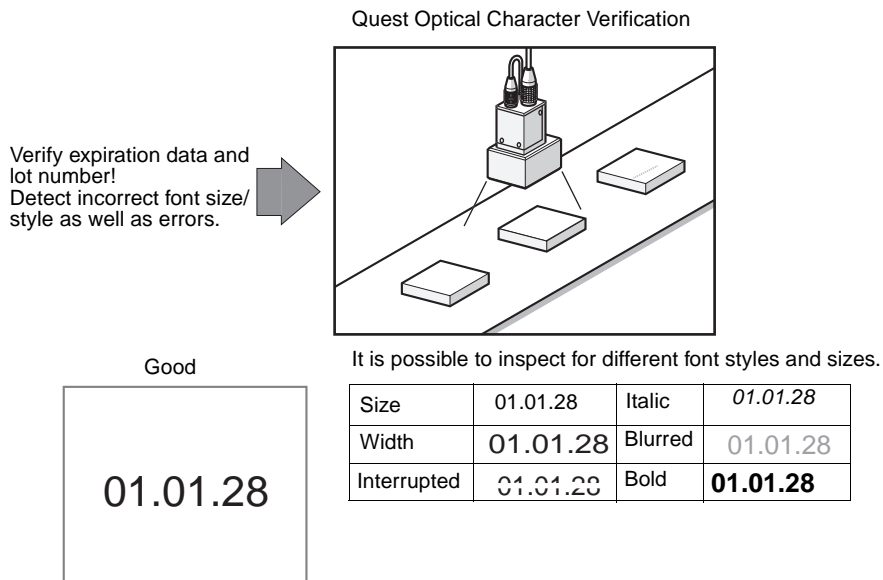
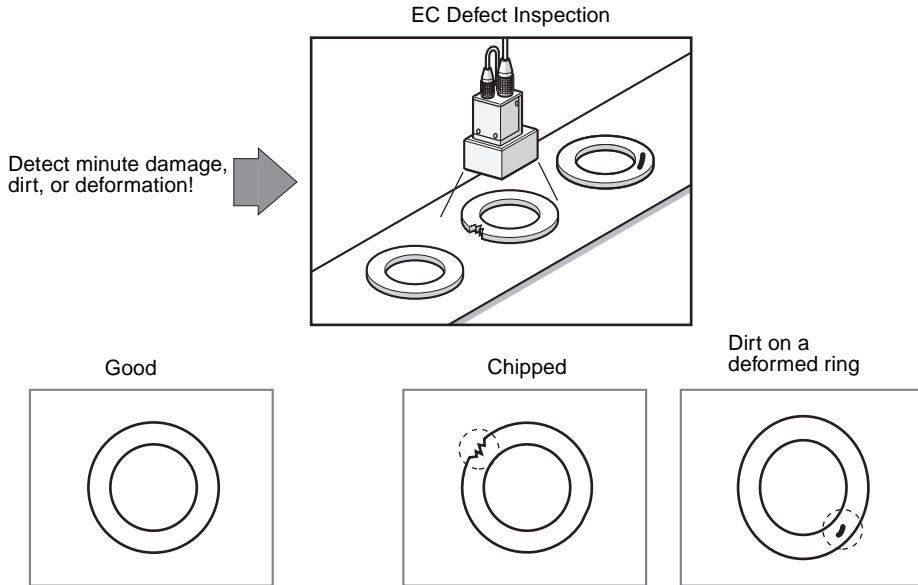

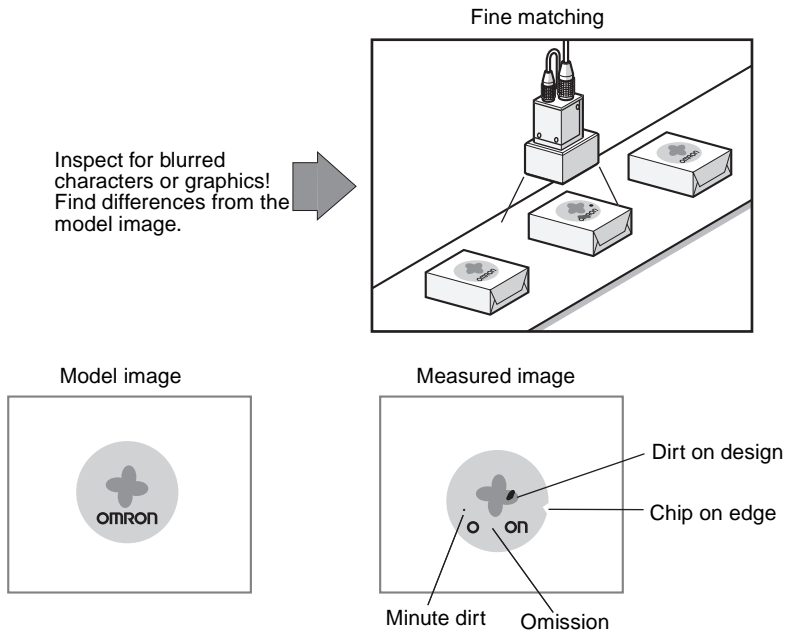
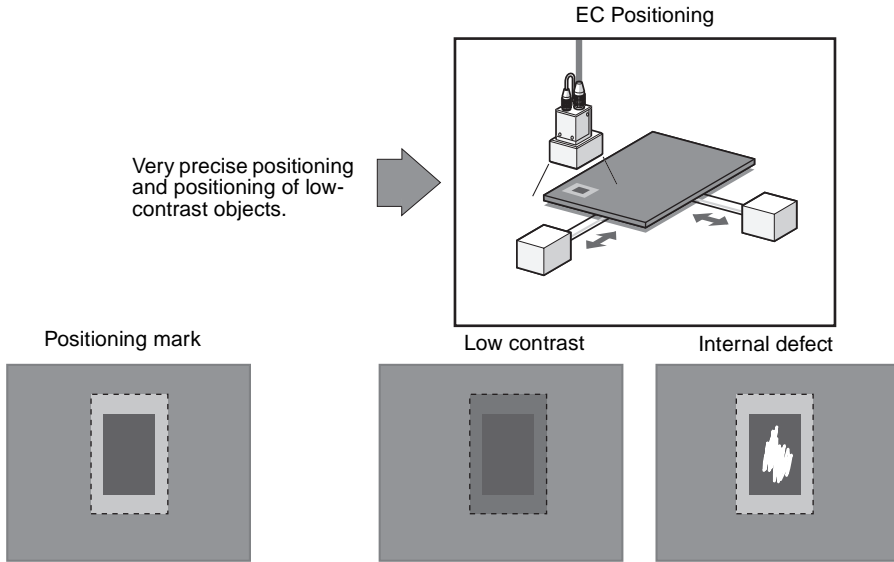

The F250 has many other inspection processes in its line-up.

2-1-2 Simple and Flexible Inspection Settings

First, install the required inspection processes from the Application Software Memory Card.

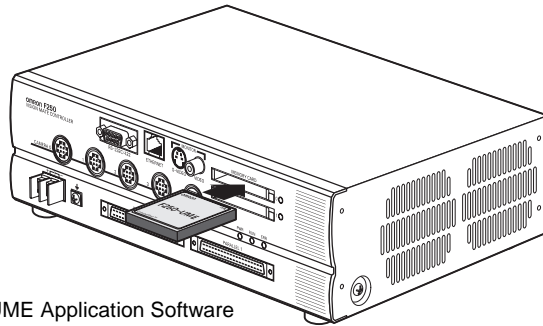

F250-UME Application Software



Processes in the menu can be combined freely.

```
0.Scen 0=SET=  
0.Camera image  
1.EC pos. comp  
2.Fine matching  
3.Binary defect  
4.DO data  
5.  
ENT:Set SFT+ESC>Edit
```

2-1-3 Smooth Switching between Processes

The scene function can be used to set up to 32 different inspections. When the inspection requirements change, the inspection process can be changed just by changing the scene. Up to 1,024 scenes can be stored on a 128-MB Memory Card.

2-2 Basic System Configuration

The following diagram shows the basic F250 system configuration.

Precaution Some of the components shown in the configuration diagram are special OMRON products that cannot be substituted with comparable devices. These items are indicated with an asterisk.

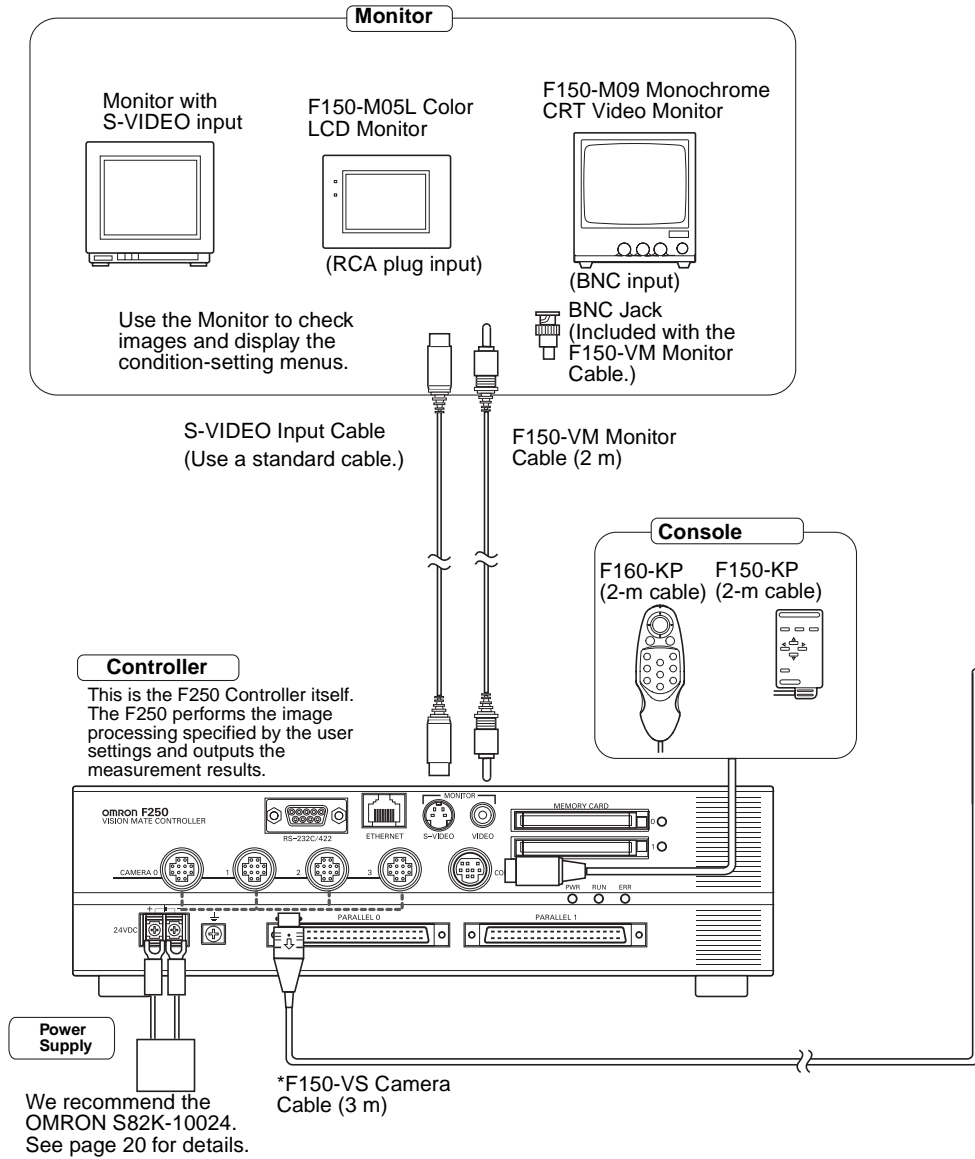

*Cameras

The Camera captures images of the measurement objects. Up to 4 Cameras can be connected to one F250 Controller.

CHECK If F150-□□□ or F160-□□□ Cameras are being used, the connected Cameras must belong to the same series, i.e., they must have the same model number prefix (F150 or F160).

• Double-speed Cameras

Camera with Intelligent Lighting
 F160-SLC20 (20-mm field of vision)
 F160-SLC50 (50-mm field of vision)

Camera Only
 F160-S1

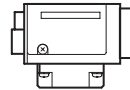
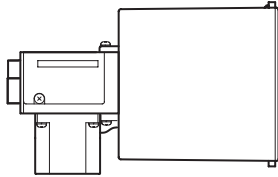

Use the Camera by itself when the field of vision of the F160-SLC□0 does not match the size of the measurement object. A standard CCTV lens and light source will be needed.

• F150 Cameras

Camera with Intelligent Lighting
 F150-SLC20 (20-mm field of vision)
 F150-SLC50 (50-mm field of vision)

Camera with Intelligent Lighting
 F150-SL20A (20-mm field of vision)
 F150-SL50A (50-mm field of vision)

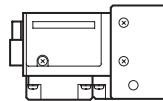
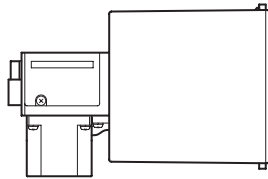

Camera Only
 F150-S1A

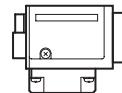

Use the Camera by itself when the field of vision of the F150-SLC□0 does not match the size of the measurement object. A standard CCTV lens and light source will be needed.

CHECK F200-series and F300-series Cameras can also be connected. Up to four Cameras can be connected, but they must all have the same model number. Only one Camera can be connected, however, when the F200-S Camera is used or when a camera with an internal sync mode is used.

Camera type	Camera Cable	Max. number of Cameras
F200-S	F160-VSR3	1 (Connect to camera connector 0.)
F300-S	F160-VSR4	4
F300-S2R	F160-VSR3	(The Cameras must have the same model number.)
F300-S3DR		
F300-S4R		

See/Also Refer to page 68 for details on parameter settings.

2-3 Component Names and Functions

The following diagram shows the F250 Controller's major components.

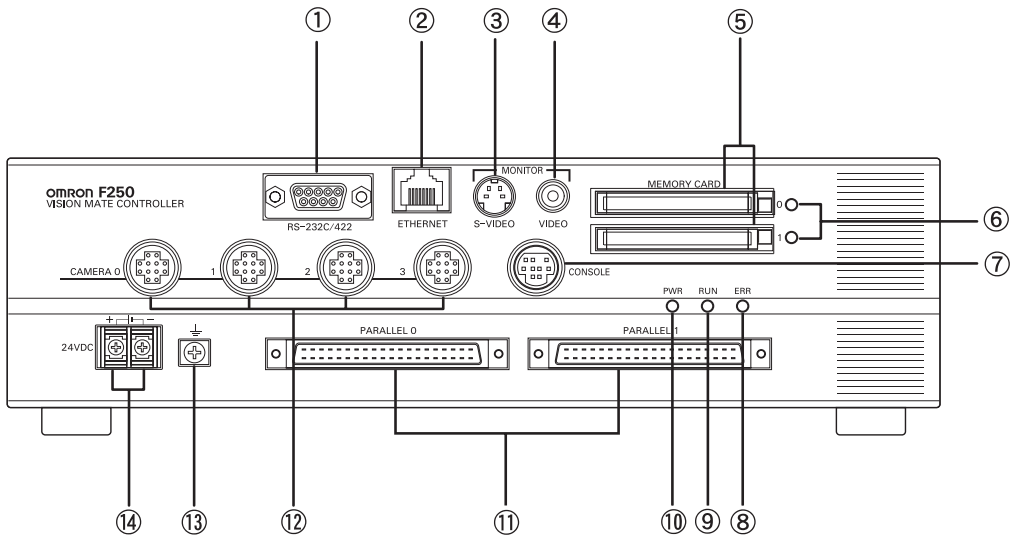

1. RS-232C/RS-422 Connector
Connects the F250 to an external device such as a personal computer or PLC.
2. Ethernet Connector (10BASE-T)
Connects the F250 to a personal computer. (Can be used with F250-UME Application Software version 1.10 or higher.)
3. Monitor Connector (S-VIDEO Output)
Connects to a monitor with an S-VIDEO input.
4. Monitor Connector (Composite Video Output)
Connects to a monitor.
5. Memory Card Slots 0 and 1
Memory Cards such as the Application Software Memory Card can be inserted in these slots.
6. Memory Card Indicators 0 and 1
Lit when power is being supplied to the corresponding Memory Card. (The Memory Card must not be inserted or removed when this indicator is lit.)
7. Console Connector
Connects the F250 to a Console.
8. ERROR Indicator
Lit when an error has occurred.
9. RUN Indicator
Lit while the F250 is in Run Mode.
10. POWER Indicator
Lit while power is ON.
11. Parallel Connectors 0 and 1
Connect the F250 to external devices such as a sync sensor or PLC.
12. Camera Connectors 0 to 3
Connect to the Cameras.
13. Ground Terminal
Connects to the ground wire.
14. Power Supply Terminals
Connect to the DC power supply.

2-4 Mounting the Controller

There are two ways to mount the Vision Mate Controller: horizontal mounting, or vertical mounting. (All dimensions are in mm.)

F250 Dimensions

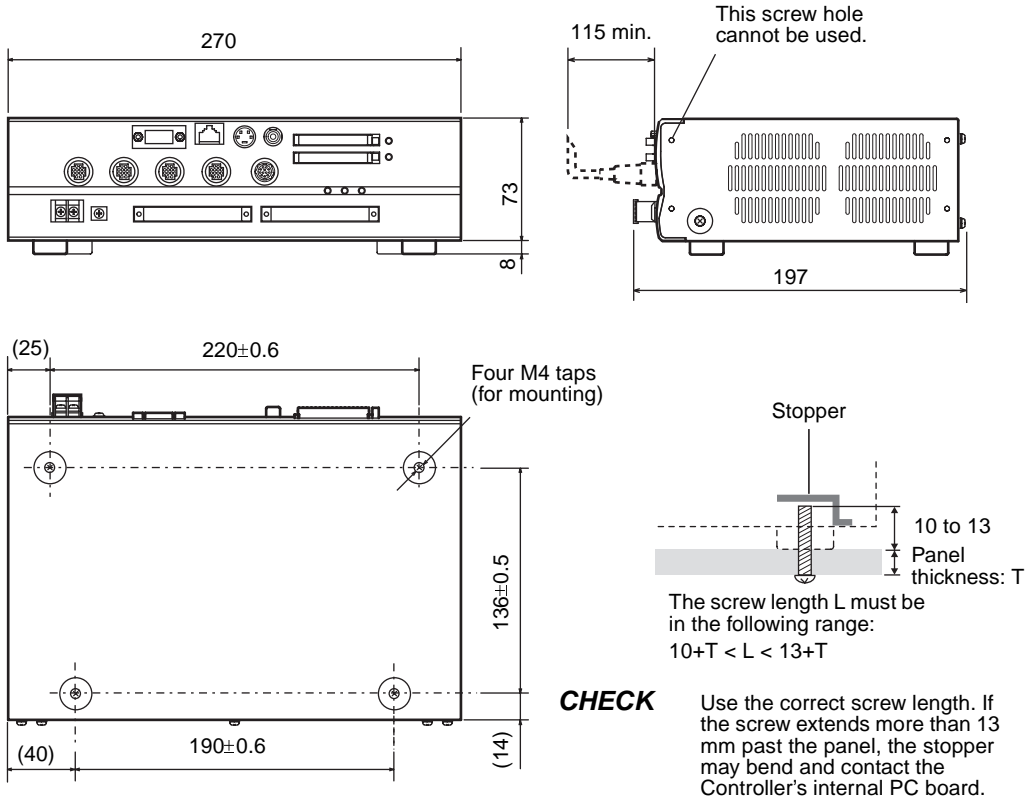

2-4-1 Horizontal Mounting

For proper air flow, provide at least 20 mm of clearance from the top of the Controller and at least 50 mm of clearance from the sides (next to the intake and exhaust vents).

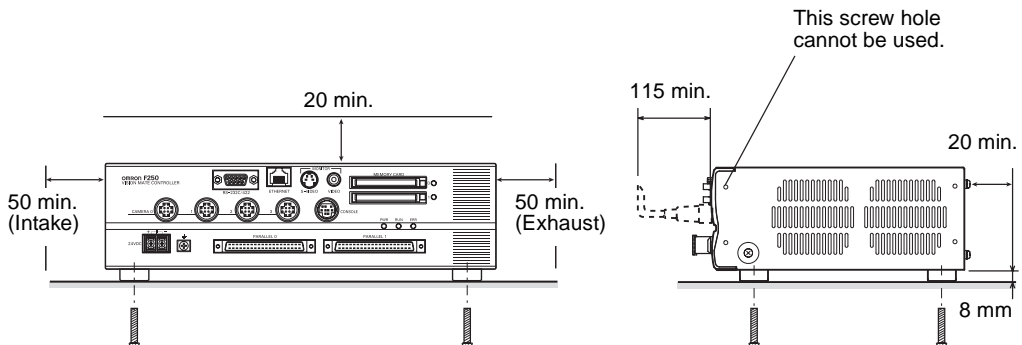

2-4-2 Vertical Mounting

For proper air flow, provide at least 20 mm of clearance from the top of the Controller and at least 50 mm of clearance from the sides (next to the intake and exhaust vents).

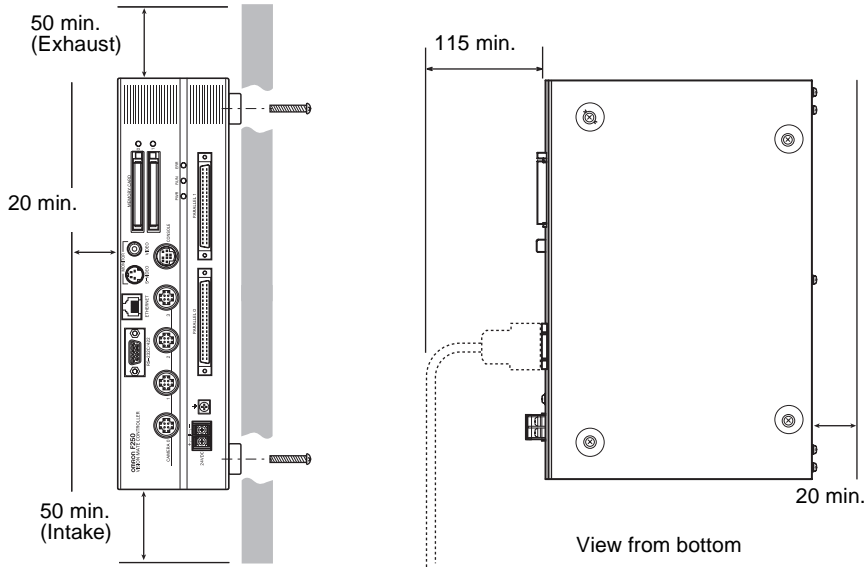

Precaution The Controller must be installed with the air intake side down and the air exhaust side up.

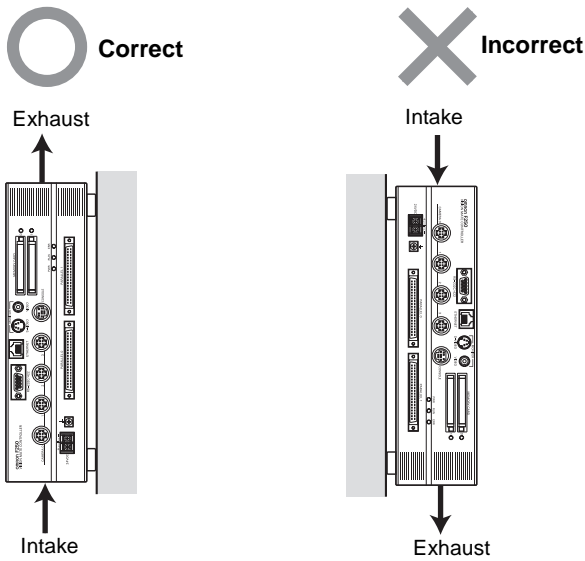

2-5 Connecting Peripheral Devices

This section shows how to connect peripheral devices to the F250.

Precaution Always turn OFF the power supply before connecting or disconnecting a peripheral device's cable. The peripheral device may be damaged if it is connected while the power is ON.

The various connectors on the F250 are capped when the F250 is shipped. When a connector is not being used, leave the cap in place or replace the cap to protect against dust, dirt, and static electricity.

2-5-1 Connecting a Console

Connect the Console to the F250's CONSOLE connector. An F160-KP or F150-KP Console can be connected. Install the provided ferrite core onto the cable, positioning the ferrite core about 10 mm from the F250-side connector.

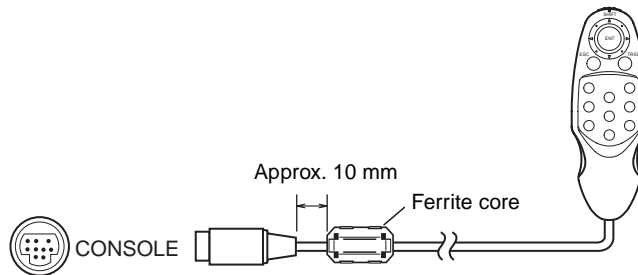

2-5-2 Connecting a Monitor

Connect the monitor cable to the F250's MONITOR connector. Install the provided ferrite core onto the F150-VM Monitor Cable, positioning the ferrite core about 10 mm from the F250-side connector. The S-VIDEO and VIDEO outputs can be used simultaneously.

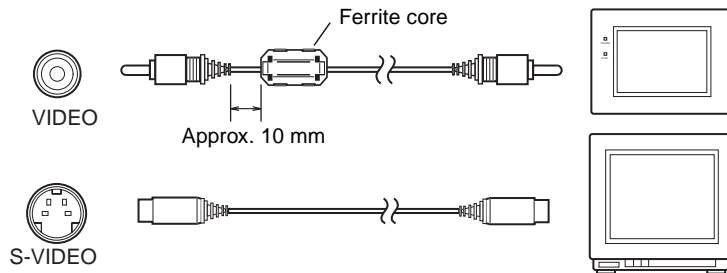

2-5-3 Connecting a Camera

Connect the camera cable to the F250's CAMERA connector.

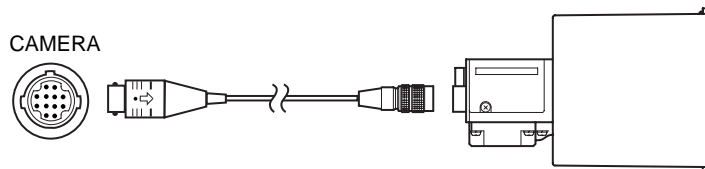

Overview of Available Cameras

The F250 Camera with Light is a special Camera that has a special lens and light source already attached. The light source and lens are contained in a sin-

gle unit, so installation is very simple. Just mount the Camera at the proper distance from the measurement object and it is ready to use.

Camera with Light

Item	F150-SL20A	F150-SL50A
Field of vision	20 mm x 20 mm	50 mm x 50 mm
Mounting distance	61 to 71 mm	66 to 76 mm
Relationship between Camera and object		
Lighting precautions	None in particular	

Camera with Intelligent Lighting

Item	F150-SLC20 or F160-SLC20	F150-SLC50 or F160-SLC50
Field of vision	20 mm x 20 mm	50 mm x 50 mm
Mounting distance	15 to 25 mm	16.5 to 26.5 mm
Relationship between Camera and object		
Lighting precautions	Use with DIP switch pins 1 and 2 both set to OFF.	Use with DIP switch pins 1 and 2 both set to OFF.

Camera Only

Item	F150-S1A or F160-S1
Field of vision and distance to object	Determine the required field of vision based on the size of the measurement object and select an appropriate CCTV lens (C mount).
Lighting precautions	Provide a light source appropriate for the measurement object.

CHECK Observe the following precautions when using a Camera with Light or Camera with Intelligent Lighting.

- The lens has a fixed focal point. The actual field of vision and focal point vary from lens to lens, so adjust the distance to the measurement object after replacing the lens or camera.
- The camera mounting distance listed in the following tables is an approximate value. Mount the Camera so that the distance to the measurement object can be adjusted easily.

If the object size and field of vision are incompatible, use a standard CCTV lens and light source.

SeeAlso page 22

2-6 Power Supply and Ground

Wire the power supply and the ground to their respective terminals. Tighten the screws to a torque of between 0.49 N·m.

After wiring, confirm that the wiring is correct.

2-6-1 Crimp Terminals and Cables

The terminal block uses M3 terminal screws. Use appropriate crimp terminals for M3 screws, as shown below.

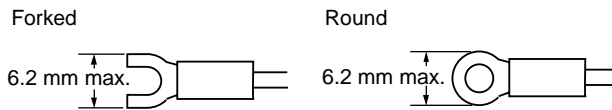

Applicable wire size: Insulated wire of 1.31 to 1.65 mm² (AWG16 to AWG15)

2-6-2 Ground (Earth) Wiring

Always connect a ground wire to the F250's ground terminal. To avoid grounding problems, do not share the ground wire with any other devices or wire the ground to the building's steel framing.

Use a grounding point that is as close as possible and keep the ground wire as short as possible.

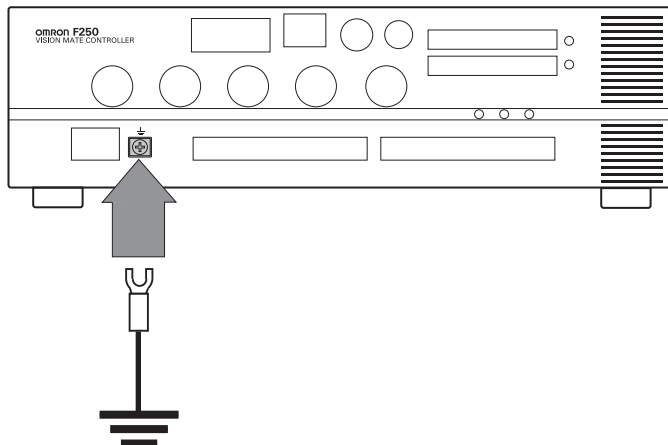

Ground to 100 Ω or less

2-6-3 Wiring the Power Supply

Wire the Power Supply Unit independently of other devices. In particular, keep the power supply wired separately from inductive loads. Also, keep the power supply wiring as short as possible (less than 10 m).

Use a power supply that meets the following specifications. We recommend using OMRON's S82K-10024 Power Supply.

Item	Specification
Output current	3.7 A min.
Power supply voltage	24 VDC +10%/−15%

CHECK Use a DC power supply with countermeasures against high voltages (safe extra low-voltage circuits on the secondary side). If the system must meet UL standards, use a UL class II power supply.

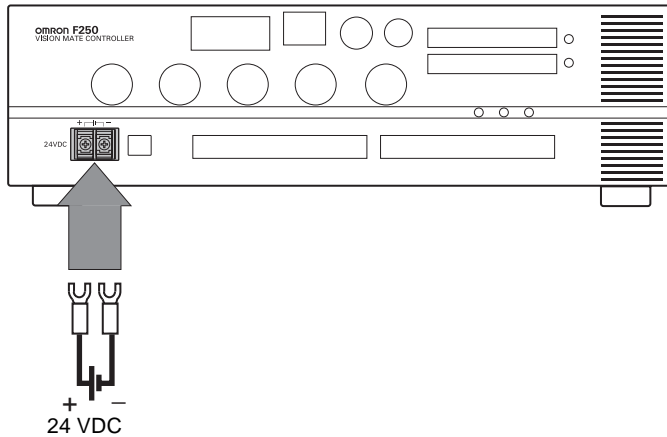

Caution Keep the power supply line as short as possible (less than 10 m). After wiring, replace the protective cover on the power supply terminals.

SECTION 3

Lenses, Lighting, and Memory Cards

This section provides additional information on CCTV lenses, lighting, and Memory Cards.

3-1	CCTV Lenses	22
3-1-1	Optical Chart	22
3-1-2	Lenses and Lens Diameters	23
3-1-3	Extension Tubes	24
3-2	Lighting	25
3-2-1	Lighting Methods	25
3-3	Memory Cards	27
3-3-1	Installing a Memory Card.	27
3-3-2	Removing the Memory Card	27
3-3-3	Using Memory Cards in a Personal Computer.	28

3-1 CCTV Lenses

When using a Camera without a light (F150-S1A or F160-S1), refer to the following graph to select the appropriate Lens and Extension Tube. The lens will differ depending on the size of the measurement object and the distance from the Camera.

3-1-1 Optical Chart

The values in the following chart are approximations, and the Camera must be adjusted after it is mounted.

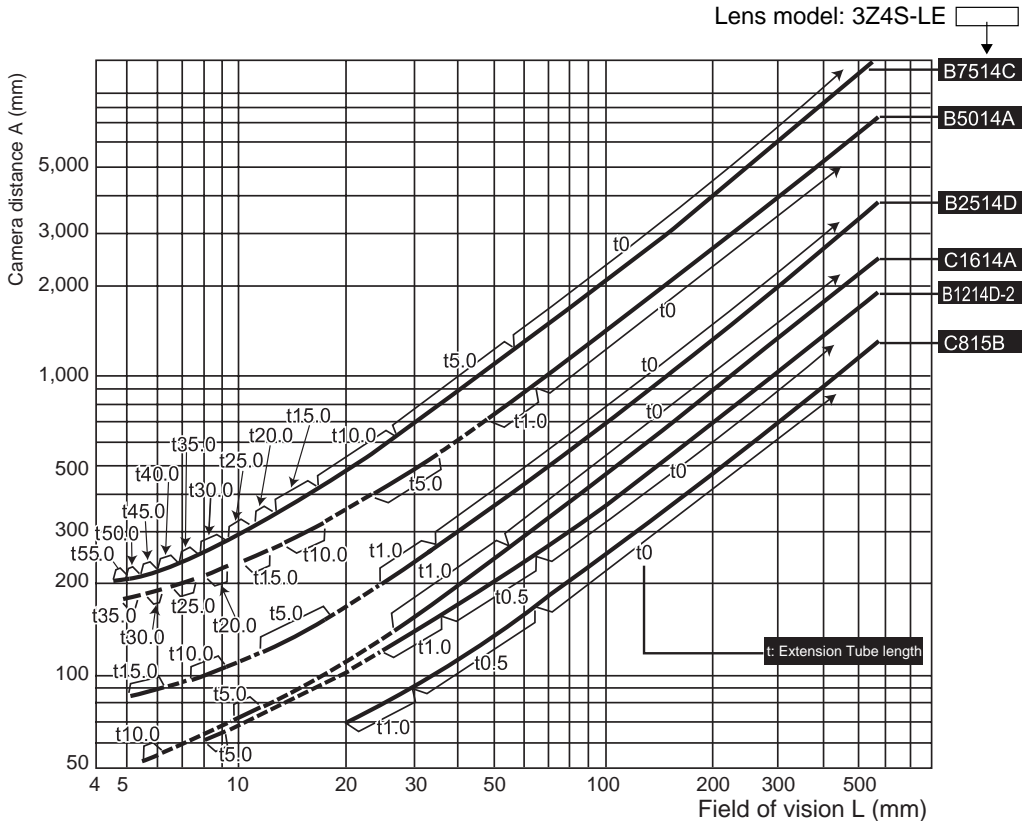

The X axis of the graph shows field of vision L (mm), and the Y axis shows the camera distance A (mm). The curves on the graph show the relationship between the field of vision and camera distance for each CCTV lens. The values are significantly different for each lens, so double-check the model of the lens before using the graph. The "t" values indicate the lengths of the Extension Tubes. The value "t0" shows the case where an Extension Tube is not needed and the value "t5.0" shows the case where a 5-mm Extension Tube is used.

Example

When a 3Z4S-LE C1614A CCTV Lens is being used and a field of vision of 40 mm is needed at the measurement object, a camera distance of 200 mm and 1-mm Extension Tube are required.

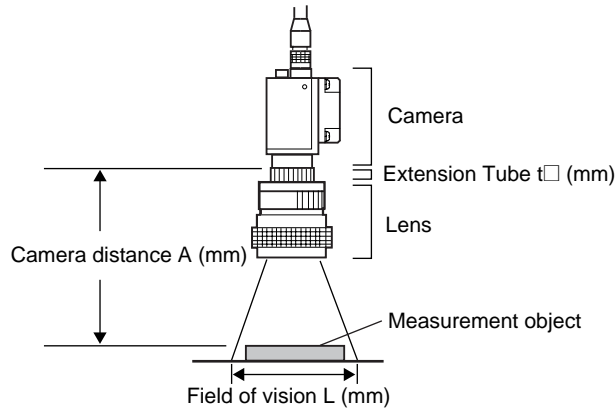

3-1-2 Lenses and Lens Diameters

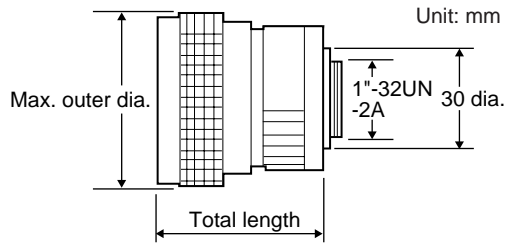

Lens	Focal length	Bright-ness	Maximum outer diameter	Total length	Filter size
3Z4S-LE C418DX	4.8 mm	F1.8	40.5 mm dia.	35.5 mm	---
3Z4S-LE B618CX-2	6.5 mm	F1.8	48 mm dia.	42 mm	
3Z4S-LE C815B	8.5 mm	F1.5	42 mm dia.	40 mm	M40.5 × P0.5
3Z4S-LE B1214D-2	12.5 mm	F1.4	42 mm dia.	50 mm	
3Z4S-LE C1614A	16.0 mm	F1.4	30 mm dia.	33 mm	M27 × P0.5
3Z4S-LE B2514D	25.0 mm	F1.4	30 mm dia.	37.3 mm	
3Z4S-LE B5014A	50.0 mm	F1.4	48 mm dia.	48 mm	M46 × P0.75
3Z4S-LE B7514C	75.0 mm	F1.4	62 mm dia.	79 mm	M58 × P0.75

3-1-3 Extension Tubes

One or more Extension Tubes can be inserted between the lens and the Camera to focus the Camera image. Use a combination of one or more of the six tubes to achieve the required length.

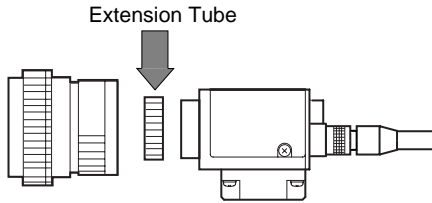

Model	Maximum outer diameter	Length
3Z4S-LE EX-C6	31 dia.	Set of 6 tubes 0.5 mm, 1 mm, 5 mm, 10 mm, 20 mm, and 40 mm

Length: 40 mm 20 mm 10 mm 5 mm 1.0 mm 0.5 mm

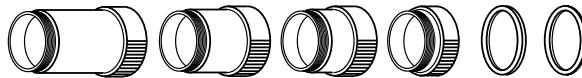

Precaution

- Do not use the 0.5-mm and 1.0-mm Extension Tubes attached to each other. Since these Extension Tubes are placed over the threaded section of the Lens or other Extension Tube, the connection may loosen when more than one 0.5-mm or 1.0-mm Extension Tube are used together.
- Reinforcement may be required for combinations of Extension Tubes exceeding 30 mm if the Camera is subject to vibration.

3-2 Lighting

A stable image must be obtained to ensure accurate inspection. Use appropriate lighting for the application and the measurement object if using a Camera without a light (F150-S1A or F160-S1).

3-2-1 Lighting Methods

Back Lighting

A stable, high-contrast image can be obtained using back lighting.

Applications: Inspection of exterior shape or positioning inspection

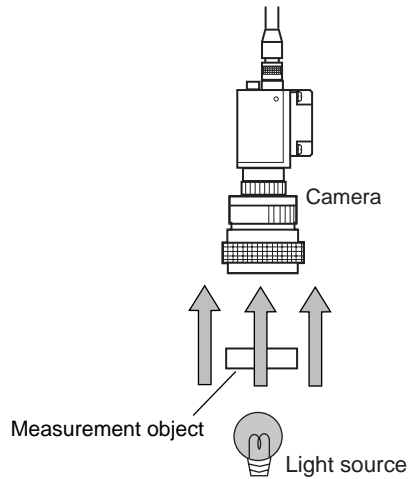

Reflected Lighting

Ring Lights

Light is shone uniformly on the measurement object.

Applications: Surface inspections

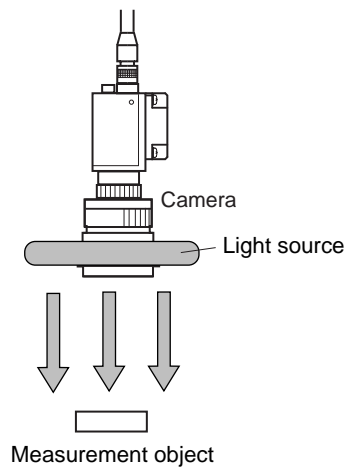

Oblique Lighting

Detection can be made utilizing the difference in regular and diffuse reflected light.

Applications: Inspections for surface gloss

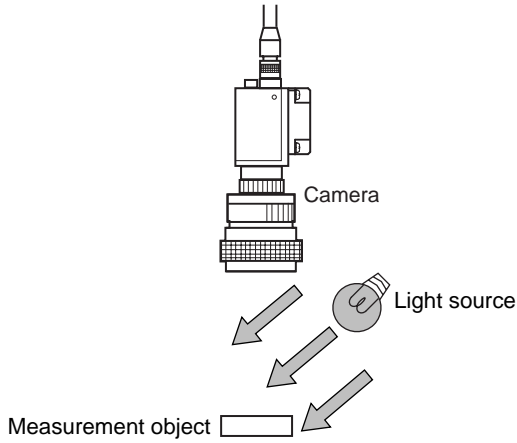

Coaxial Lighting

A stable image can be obtained with few shadows from uneven surfaces on the measurement object.

Applications: Surface inspections, positioning, and hole inspections of comparatively small objects

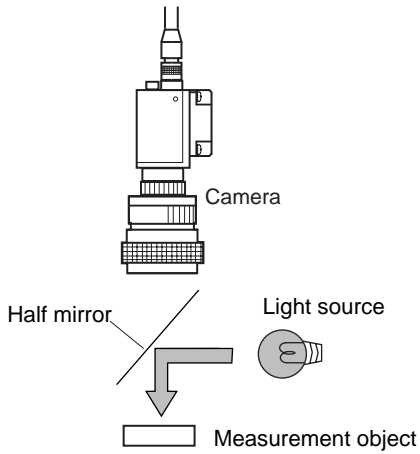

3-3 Memory Cards

Use a Memory Card to back up data such as settings and image data or increase the number of scenes when you are using the Scene Group function. Data from the F250 can be backed up in the computer just by inserting the Memory Card into the computer and copying the desired data. The following procedures also apply to the Memory Card containing the F250-UME Application Software.

We recommend the OMRON F160-N64S (64 MB).

CHECK The F250 is equipped with two Memory Card slots. Use these slots for the following functions.

Function	Slot number
F250-UME Application Software installation	Slot 0 (Use slot 0 only.)
Memory Cards for scene groups	Slot 1 (Use slot 1 only.)
Memory Cards for data backup	Either slot 0 or 1 can be used.

Precaution A filler card with no memory is inserted into the F250's Memory Card slot before the F250 is shipped. Remove this filler card and install a Memory Card to use the Memory Card functions. If Memory Cards are not being used, leave the filler card in place to prevent dust or dirt from entering the Memory Card slot.

3-3-1 Installing a Memory Card

1. Insert the Memory Card into the Memory Card slot.

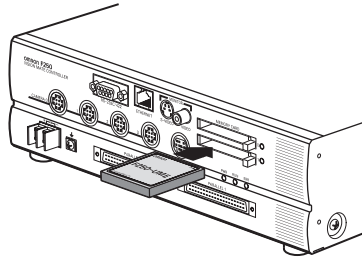

CHECK The eject button will pop out slightly when the Memory Card is inserted properly.

3-3-2 Removing the Memory Card

1. Turn OFF the power supply to the Memory Card or turn OFF the F250.

SeeAlso Refer to *Section 4 Additional Functions* in the *F250 Vision Sensor Manual 2: Operation Manual* for details on turning OFF the power supply to the Memory Card.

2. Verify that the Memory Card indicator is not lit.

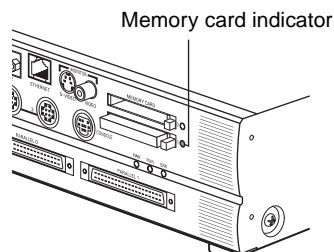

- Precaution** Do not remove the Memory Card if the Memory Card indicator is lit. Doing so may damage the Memory Card or the F250 itself.
3. Press the eject button to the right of the Memory Card slot. The Memory Card will pop out slightly.

Precaution Do not remove the Memory Card without pressing the eject button. Doing so may damage the F250.

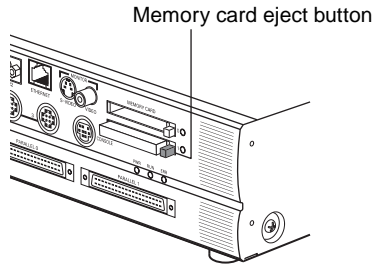

4. Pull the Memory Card straight out from the slot.

3-3-3 Using Memory Cards in a Personal Computer

The F250's Memory Cards can be used in a personal computer with a PC Card drive (PCMCIA 2.0 or higher, type II compatible) or CompactFlash™ drive.

The Memory Card must be inserted into a PC Card Adapter in order to be used in a PC Card drive. We recommend the OMRON HMC-AP001 PC Card Adapter.

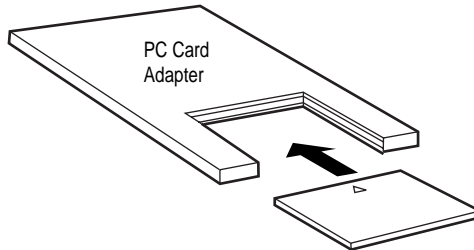

SECTION 4

Connecting External Devices

This section describes how to connect external devices through a parallel interface (a parallel connector) or serial interface (the RS-232C/RS-422 connector or Ethernet connector).

4-1	Connecting through the Parallel Interface	30
4-1-1	Parallel Connection Methods	30
4-1-2	Parallel Connector Specifications.	32
4-1-3	I/O Specifications	36
4-2	Connecting through the Serial Interface	37
4-2-1	RS-232C/RS-422 Connections.	37
4-2-2	Ethernet Connection	40

4-1 Connecting through the Parallel Interface

This section explains how to connect I/O to the F250 through its parallel interface to input signals such as measurement triggers or output signals such as measurement results.

When you want to use the parallel interface to input commands and output measurement results, prepare a parallel I/O cable and connect it to the parallel connector. A Terminal Block can also be used to connect external devices. Refer to the *F250 Vision Sensor Manual 2: Operation Manual* for details on communications settings and I/O formats.

4-1-1 Parallel Connection Methods

Using a Parallel I/O Cable

Use an F160-VP Parallel I/O Cable (sold separately) to connect the F250 to external devices. Align the connectors and insert the cable's connector straight into the F250's parallel connector. Tighten the connector's mounting screws to secure the connection.

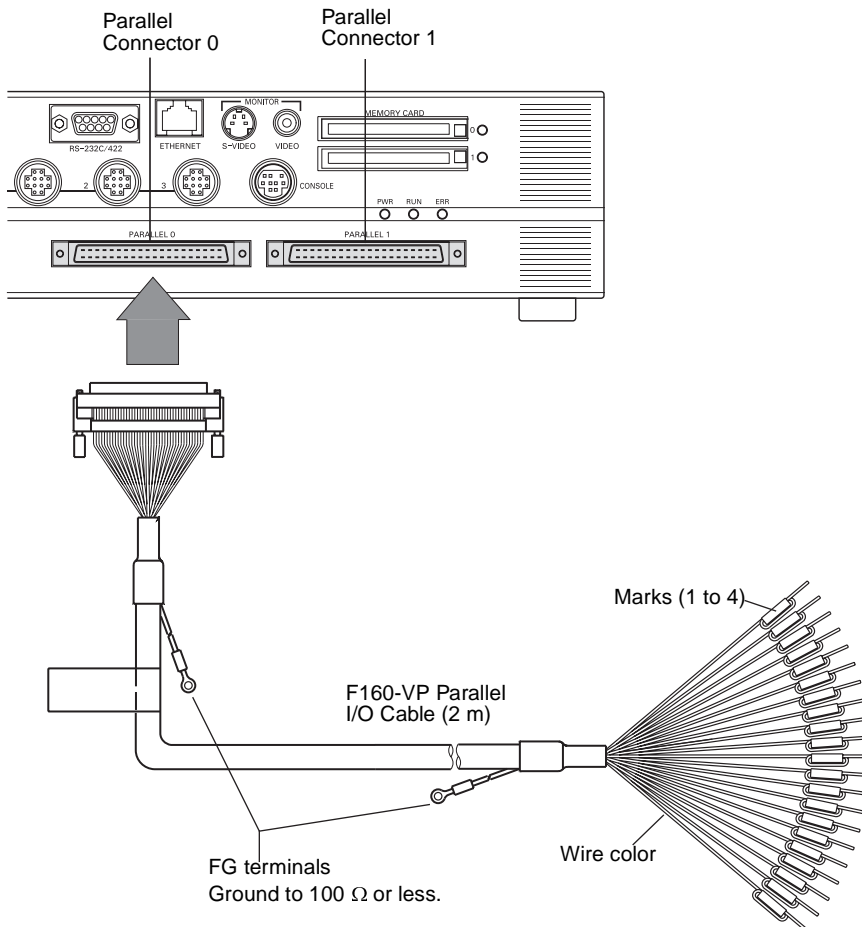

- Precaution**
1. Turn OFF the power supply before connecting or disconnecting a Parallel I/O Cable. Peripheral devices may be damaged if the cable is connected or disconnected with the power ON.

- The parallel connectors are capped with screw-on covers when the F250 is shipped. When a connector is not being used, leave the cover in place or replace the cover to protect against dust, dirt, and static electricity.

Using a Screw Terminal Block

Use a Screw Terminal Block and Special Cable to connect the F250 to external devices such as PLCs.

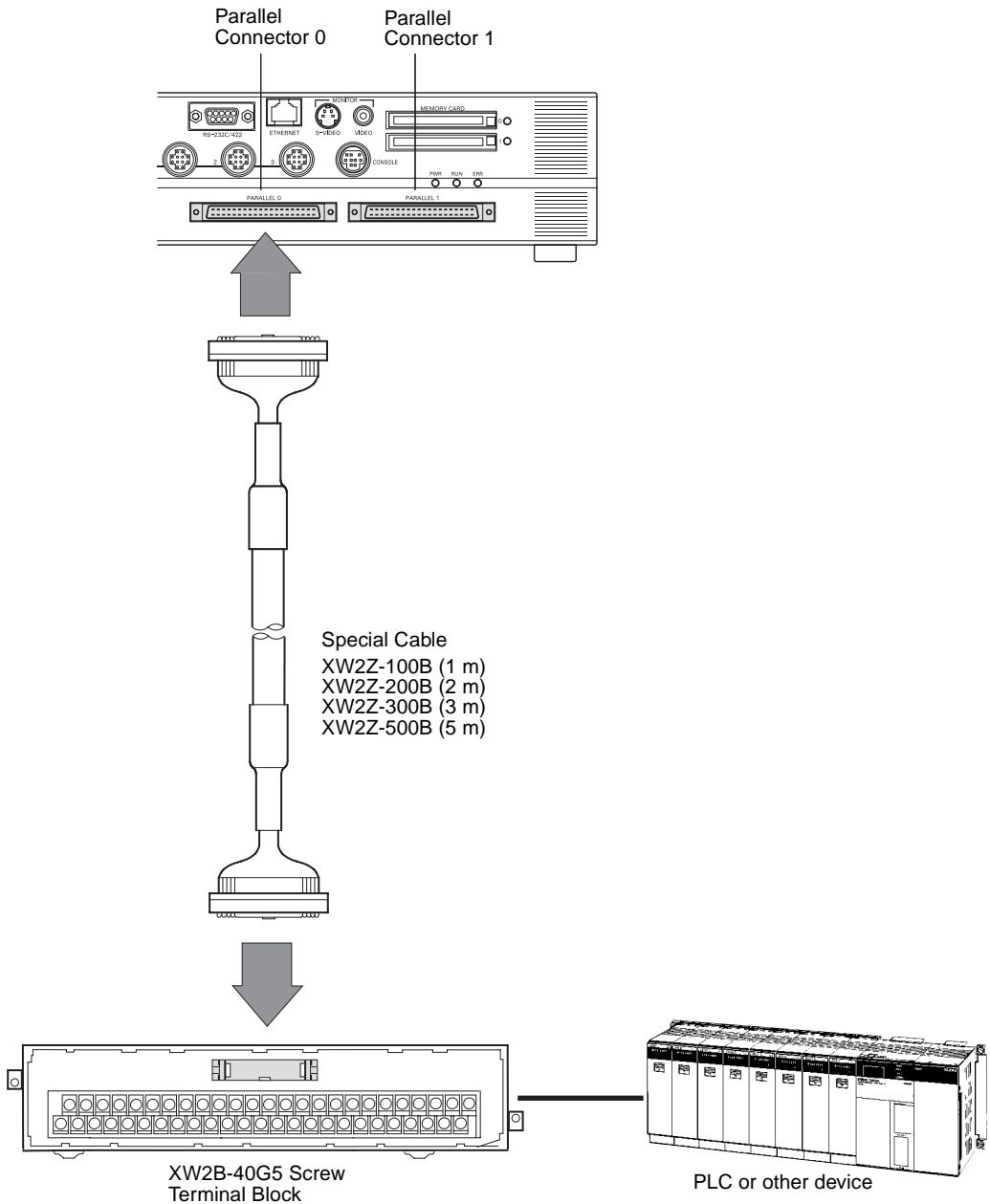

4-1-2 Parallel Connector Specifications

Parallel Connector 0

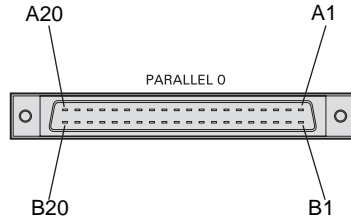

Each wire of the F160-VP Parallel I/O Cable has a unique wire-color/mark combination.

Pin	Signal	Color	Mark (Black)	Function	Pin	Signal	Color	Mark (Red)	Function	
A1	RESET	Lt. brown	■	Restarts the F250.	B1	COMIN1	Lt. brown	■	Common for input signals (See note 2.)	
A2	STEP	Yellow	■	Measurement trigger signal input	B2	DSA	Yellow	■	Inputs data send request signals	
A3	DI0	Green	■	Command input	B3	DI1	Green	■	Command input	
A4	DI2	Gray	■		B4	DI3	Gray	■		
A5	DI4	White	■		B5	DI5	White	■		
A6	DI6	Lt. brown	■■		B6	DI7	Lt. brown	■■		
A7	(Open)	Yellow	■■	(Leave open.)	B7	(Open)	Yellow	■■	(Leave open.)	
A8	STGOUT0	Green	■■	Strobe trigger 0 output (See note 1.)	B8	STGOUT1	Green	■■	Strobe trigger 1 output (See note 1.)	
A9	RUN	Gray	■■	ON while in Run mode	B9	ERROR	Gray	■■	ON when there is an error.	
A10	BUSY	White	■■	ON during processing	B10	GATE	White	■■	ON for the set output time	
A11	OR	Lt. brown	■■■	Combined judgement result	B11	COMOUT1	Lt. brown	■■■	Common for control signals (See note 3.)	
A12	DO0	Yellow	■■■	Data output	B12	DO1	Yellow	■■■	Data output	
A13	DO2	Green	■■■		B13	DO3	Green	■■■		
A14	DO4	Gray	■■■		B14	DO5	Gray	■■■		
A15	DO6	White	■■■		B15	DO7	White	■■■		
A16	DO8	Lt. brown	■■■■		B16	COMOUT2	Lt. brown	■■■■		Common for DO0 to DO7
A17	DO9	Yellow	■■■■		B17	DO10	Yellow	■■■■		Data output
A18	DO11	Green	■■■■		B18	DO12	Green	■■■■		
A19	DO13	Gray	■■■■		B19	DO14	Gray	■■■■		
A20	DO15	White	■■■■	B20	COMOUT3	White	■■■■	Common for DO8 to DO15		

Precaution Do not input the RESET input immediately after turning ON the power. When using RESET input to synchronize startup timing, wait at least 1 s after turning ON the F250's power supply before turning ON the RESET signal.

CHECK Use a DC power supply with countermeasures against high voltages (safe extra low-voltage circuits on the secondary side) for the COMIN and COMOUT terminals. If the system must meet UL standards, use a UL class II power supply.

Parallel Connector 1

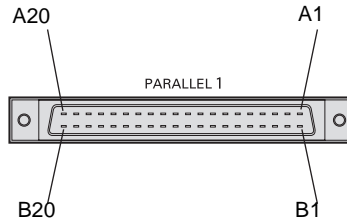

Each wire of the F160-VP Parallel I/O Cable has a unique wire-color/mark combination.

Pin	Signal	Color	Mark (Black)	Function	Pin	Signal	Color	Mark (Red)	Function
A1	(Open)	Lt. brown	■	(Leave open.)	B1	COMIN2	Lt. brown	■	Common for input signals (See note 2.)
A2	Reserve input	Yellow	■	(Leave open.)	B2	Reserve input	Yellow	■	(Leave open.)
A3	DI8	Green	■	Command input	B3	DI9	Green	■	Command input
A4	DI10	Gray	■		B4	DI11	Gray	■	
A5	DI12	White	■		B5	DI13	White	■	
A6	DI14	Lt. brown	■ ■		B6	DI15	Lt. brown	■ ■	
A7	(Open)	Yellow	■ ■	(Leave open.)	B7	(Open)	Yellow	■ ■	(Leave open.)
A8	STGOUT2	Green	■ ■	Strobe trigger 2 output (See note 1.)	B8	STGOUT3	Green	■ ■	Strobe trigger 3 output (See note 1.)
A9	Reserve outputs	Gray	■ ■	(Leave open.)	B9	Reserve output	Gray	■ ■	(Leave open.)
A10		White	■ ■	(Leave open.)	B10	Reserve output	White	■ ■	(Leave open.)
A11		Lt. brown	■ ■ ■	(Leave open.)	B11	COMOUT4	Lt. brown	■ ■ ■	Common for control signals (See note 3.)
A12	DO16	Yellow	■ ■ ■ ■	Data output	B12	DO17	Yellow	■ ■ ■ ■	Data output
A13	DO18	Green	■ ■ ■ ■		B13	DO19	Green	■ ■ ■ ■	
A14	DO20	Gray	■ ■ ■ ■		B14	DO21	Gray	■ ■ ■ ■	
A15	DO22	White	■ ■ ■ ■		B15	DO23	White	■ ■ ■ ■	
A16	DO24	Lt. brown	■ ■ ■ ■ ■		B16	COMOUT5	Lt. brown	■ ■ ■ ■ ■	
A17	DO25	Yellow	■ ■ ■ ■ ■	B17	DO26	Yellow	■ ■ ■ ■ ■	Data output	
A18	DO27	Green	■ ■ ■ ■ ■	B18	DO28	Green	■ ■ ■ ■ ■		
A19	DO29	Gray	■ ■ ■ ■ ■	B19	DO30	Gray	■ ■ ■ ■ ■		
A20	DO31	White	■ ■ ■ ■ ■	B20	COMOUT6	White	■ ■ ■ ■ ■		Common for DO24 to DO31

Note 1. Refer to page 70 for details if you want to connect a strobe device to the F250.

Each Camera has its own strobe trigger output as shown in the following table.

Camera	Strobe trigger output signal
Camera 0	STGOUT0 (Pin A8 of parallel connector 0)
Camera 1	STGOUT1 (Pin B8 of parallel connector 0)
Camera 2	STGOUT2 (Pin A8 of parallel connector 1)
Camera 3	STGOUT3 (Pin B8 of parallel connector 1)

2. COMIN1 is the common for A1 to A6 and B2 to B6 on connector 0.
COMIN2 is the common for A3 to A6 and B3 to B6 on connector 1.
3. COMOUT1 is the common for A8 to A11 and B8 to B10 on connector 0.
COMOUT4 is the common for A8 and B8 on connector 1.

Wiring Connector-Terminal Block Conversion Units

Connector-Terminal Block Conversion Unit

Manufacturer	Model
OMRON	XW2B-40G5

Connecting Cables

Manufacturer	Model
OMRON	XW2Z-100B (1 m)
	XW2Z-200B (2 m)
	XW2Z-300B (3 m)
	XW2Z-500B (5 m)

Connecting to the F250

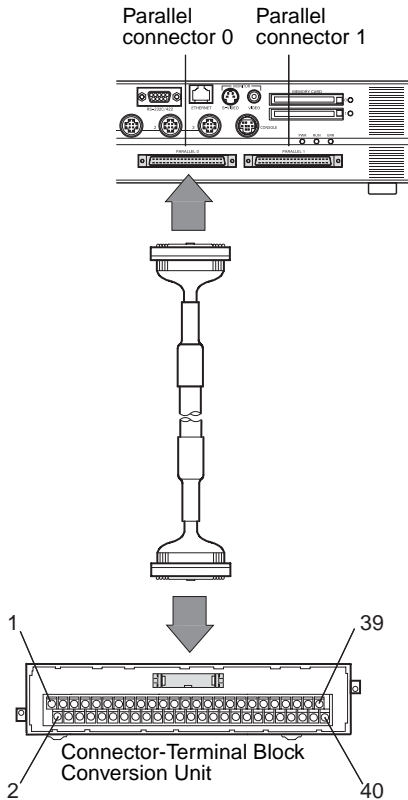

Connecting to Parallel Connector 0

Conversion Unit Terminal	Signal	Conversion Unit Terminal	Signal
1	RESET	2	COMIN1
3	STEP	4	DSA
5	DI0	6	DI1
7	DI2	8	DI3
9	DI4	10	DI5
11	DI6	12	DI7
13	Not used.	14	Not used.
15	STGOUT0	16	STGOUT1
17	RUN	18	ERROR
19	BUSY	20	GATE
21	OR	22	COMOUT1
23	DO0	24	DO1
25	DO2	26	DO3
27	DO4	28	DO5
29	DO6	30	DO7
31	DO8	32	COMOUT2
33	DO9	34	DO10
35	DO11	36	DO12
37	DO13	38	DO14
39	DO15	40	COMOUT3

Connecting to Parallel Connector 1

Conversion Unit Terminal	Signal	Conversion Unit Terminal	Signal
1	Not used.	2	COMIN2
3	Reserve input	4	Reserve input
5	DI8	6	DI9
7	DI10	8	DI11
9	DI12	10	DI13
11	DI14	12	DI15
13	Not used.	14	Not used.
15	STGOUT2	16	STGOUT3
17	Reserve output	18	Reserve output
19	Reserve output	20	Reserve output
21	Reserve output	22	COMOUT4
23	DO16	24	DO17
25	DO18	26	DO19
27	DO20	28	DO21
29	DO22	30	DO23
31	DO24	32	COMOUT5
33	DO25	34	DO26
35	DO27	36	DO28
37	DO29	38	DO30
39	DO31	40	COMOUT6

See Also Refer to the beginning of 4-1-2 *Parallel Connector Specifications* for signal definitions.

Making a Parallel I/O Cable

A parallel I/O cable can be assembled using the following connector and cover or equivalent components. Keep the cable length less than 30 m.

Component	Manufacturer	Model number
Connector	Fujitsu	FCN-360J040-AU
Cover	Fujitsu	FCN-360C040-B

CHECK Double-check the connector wiring for mistakes before turning ON the power supply for the first time.

4-1-3 I/O Specifications

Input Specifications

Item	Specification	
	F250-C50 (NPN mode)	F250-C55 (PNP mode)
Model	F250-C50 (NPN mode)	F250-C55 (PNP mode)
Input voltage	12 to 24 VDC $\pm 10\%$	
ON current	5 to 15 mA	
ON voltage	8.8 V max.	
OFF current	0.1 mA max.	
OFF voltage	4.5 V min.	
ON delay	RESET input: 10 ms max. Other inputs: 0.5 ms max.	
OFF delay	RESET input: 15 ms max. Other inputs: 0.7 ms max.	
Internal circuits		

Output Specifications

Item	Specification	
	F250-C50 (NPN mode)	F250-C55 (PNP mode)
Model	F250-C50 (NPN mode)	F250-C55 (PNP mode)
Output voltage	12 to 24 VDC $\pm 10\%$	
Load current	45 mA max.	
ON residual voltage	2 V max.	
OFF leakage current	0.1 mA max.	
Internal circuits		

Precaution Do not exceed the maximum load current specified for the F250. The F250 will be damaged if an output is short-circuited.

4-2 Connecting through the Serial Interface

The F250's serial interface (RS-232C/RS-422 connector or Ethernet connector) can be used to input signals such as measurement triggers or output signals such as measurement results. Additionally, data that has been set in the F250 can be backed up in a personal computer.

Refer to *Section 6 Communicating with External Devices* in the *F250 Vision Sensor Manual 2: Operation Manual* for details on communications settings and I/O formats.

4-2-1 RS-232C/RS-422 Connections

Connection Examples

1:1 Connection (Normal, Menu Operation)

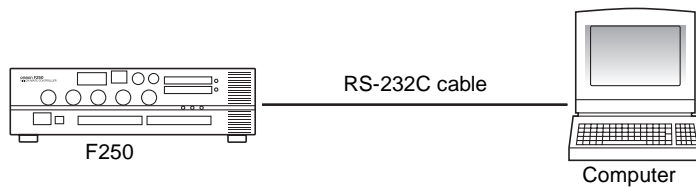

Multi-drop Connection (Normal)

Communications between one computer and several F250s is possible using Link Adapters.

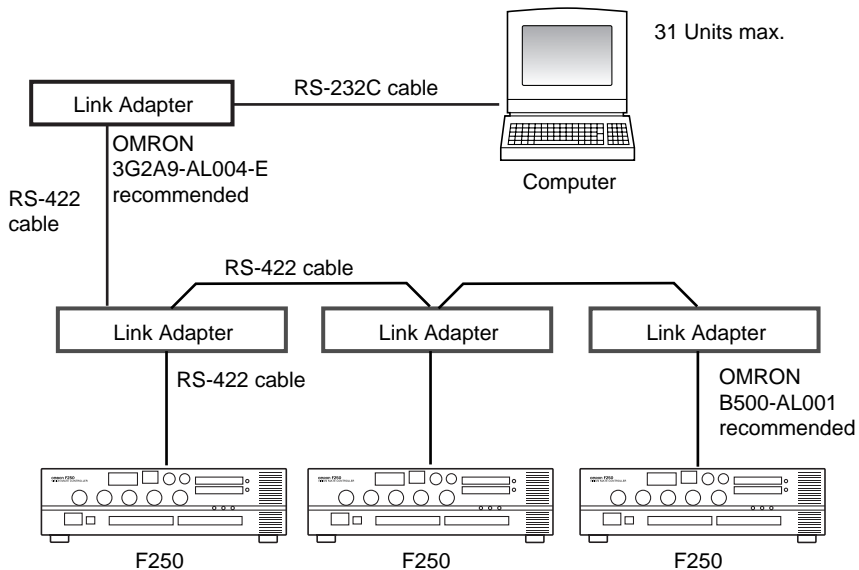

CHECK When 3G2A9-AL004-E Link Adapters are being used, termination must be set to ON in the last node in the line and the node must be terminated as follows:

- Connect 220 Ω (1/2 W min.) between RDA(-) and RDB(+).
- Connect 220 Ω (1/2 W min.) between SDA(-) and SDB(+).

1:1 Connection (Host Link)

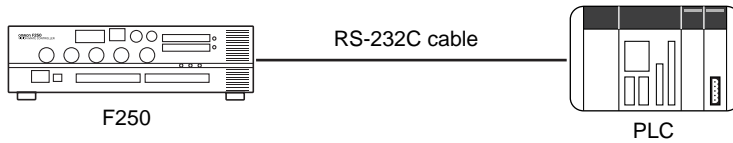

Connector

The F250's RS-232C/RS-422 Connector is a 9-pin D-SUB female connector. The pin allocation is shown below.

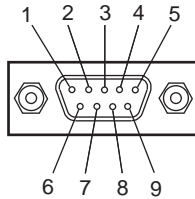

Pin	Signal	Name
1	FG	Protective frame ground
2	SD	For RS-232C
3	RD	
4	NC	Not connected
5	RDB(+)	For RS-422
6	RDA(-)	
7	SDB(+)	
8	SDA(-)	
9	GND	Signal ground

The following plug and hood are recommended and are available from OMRON.

Model	Model No.
Plug	XM2A-0901
Hood	XM2S-0911

Wiring

The maximum cable length is 15 m for RS-232C or RS-422

RS-232C Wiring

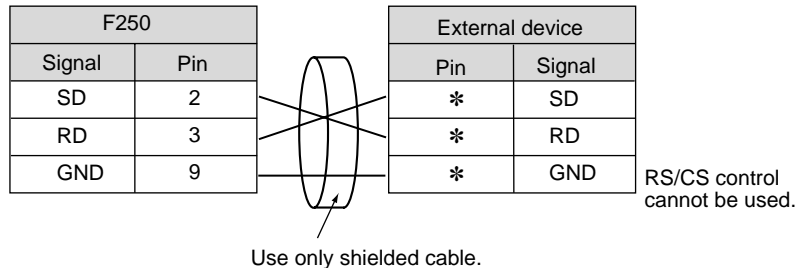

RS-422 Wiring

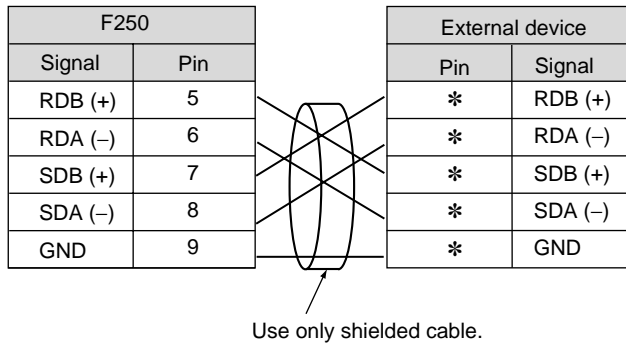

Note Pin numbers on the external device will depend on the device being connected. Refer to the manual for the personal computer or PLC being connected.

Connection

Align the connector with the socket and press the connector straight into place. Tighten the two mounting screws to secure the connector.

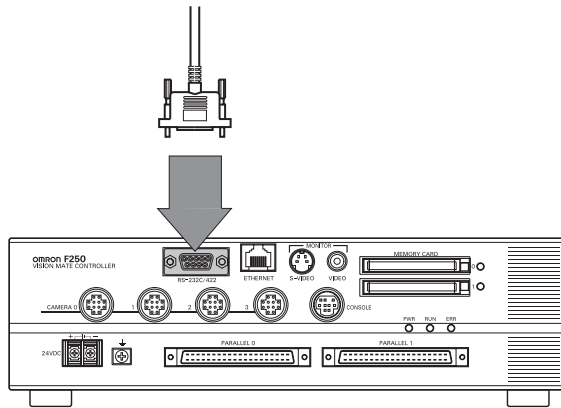

Precaution Always turn OFF the power supply before connecting or disconnecting cables. The peripheral device may be damaged if connected or disconnected with the power supply turned ON.

Note The connector is capped when the F250 is shipped. When not using the serial interface, leave the cap in place to protect against dust, dirt, and static electricity.

4-2-2 Ethernet Connection

Connection Examples

■ 1:1 Connection

Use a Shielded (STP) 10 Base-T Crossover Cable to make the 1:1 connection. The cable length must be less than 30 m.

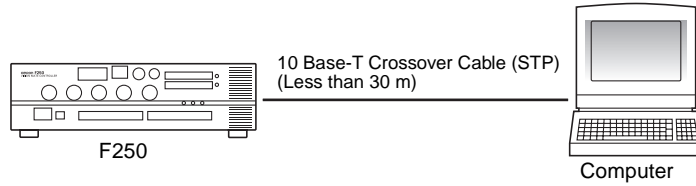

■ 1:N Connection

A Hub can be used to communicate with two or more F250s from a single computer. Use Shielded (STP) 10 Base-T Straight-through Cables to make the 1:N connections. The cable length between the F250s and the Hub must be less than 30 m.

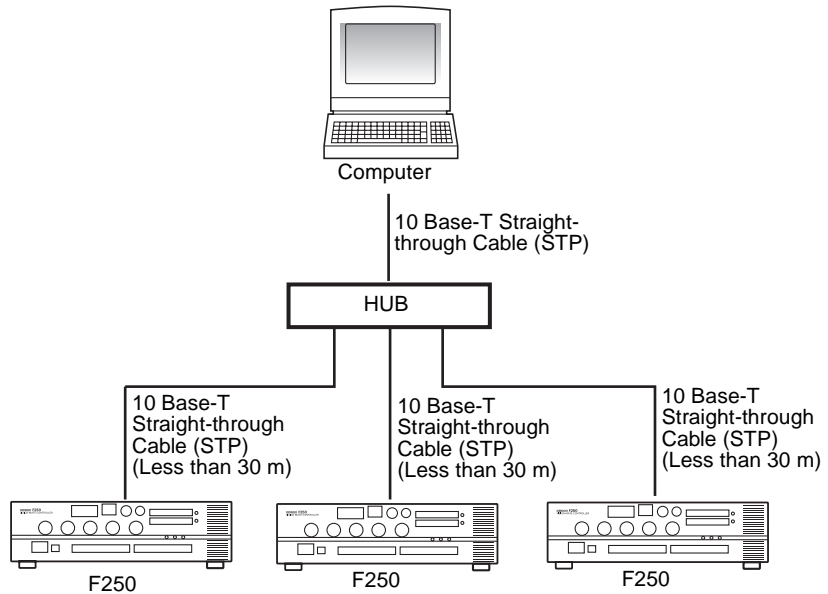

Connection

Align the connector with the socket and press the connector straight into place.

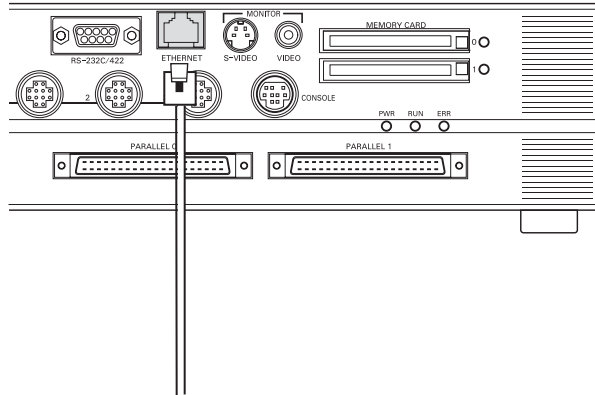
**Precaution**

1. Always turn OFF the power supply before connecting or disconnecting cables. The peripheral device may be damaged if connected or disconnected with the power supply turned ON.
2. The Ethernet connector is capped when the F250 is shipped. When the Ethernet interface isn't being used, leave the cap in place or replace the cap to protect against dust, dirt, and static electricity.

CHECK

Refer to *Section 6 Communicating with External Devices* in the *F250 Vision Sensor Manual 2: Operation Manual* for details on setting the F250's IP Address and Subnet Mask.

SECTION 5

Troubleshooting and Maintenance

This section provides tables to help identify and correct hardware errors that may occur with the F250 as well as information on maintenance and periodic inspections.

5-1	Troubleshooting	44
5-1-1	Connection Errors.	44
5-1-2	Menu Operation Errors.	44
5-1-3	Parallel Interface Errors	44
5-1-4	Serial Interface (RS-232C/RS-422) Errors.	45
5-1-5	Cameras	45
5-1-6	Memory Cards	45
5-1-7	Serial Interface (Ethernet) Errors	46
5-1-8	Cabling Errors	46
5-2	Maintenance	46
5-2-1	Replacing the Light	46
5-3	Regular Inspections.	49
5-4	Specifications	50
5-5	F200/F300 Camera Parameters.	68
5-6	Connecting a Strobe Device	70

5-1 Troubleshooting

This section lists probable corrections for common hardware problems. Please check all of the following items before requesting repairs.

5-1-1 Connection Errors

Problem	Probable cause
The POWER indicator is not lit.	The Power Supply is not connected properly.
	The supply voltage is not 24 VDC $+10\%$ / -15% .
The Video Monitor is blank.	The power to the Video Monitor is not ON.
	The Monitor Cable is not connected properly.
	The Video Monitor is malfunctioning.
	When using an LCD Monitor, the power supply capacity is insufficient.
The Video Monitor image is not clear.	There is electrical noise entering from the power supply or cables.
	The Monitor Cable is not correctly connected.
Cannot make key inputs from the Console.	The Console Cable is not correctly connected.
Camera images do not appear on the screen (for Cameras with Light Source).	The Camera Cable is not correctly connected.
	The lighting cable is not properly connected to the Camera.
Camera images do not appear on the screen (when a standard CCTV lens and lighting are used).	The lens cap has not been removed.
	The Camera Cable is not properly connected.
	The lens iris is opened or closed too far.
	The shutter speed is not suitable.
The indicators do not turn ON (for Cameras with Light Source).	The lighting method is not suitable.
	The lighting cable is not correctly connected to the Camera.
	Power is not being supplied to the F250.
	When using a Camera with Intelligent Lighting, the DIP switch pins are not set to 0.

5-1-2 Menu Operation Errors

Problem	Probable cause
The measurement results are not displayed on the Video Monitor.	The F250 is not in Monitor or Run mode.

5-1-3 Parallel Interface Errors

Problem	Probable cause
Trigger signals (input signals) are not received.	The cables are not correctly wired.
	The signal line is disconnected. The status of communications can be checked with the I/O monitor.
	The F250 is not in Monitor or Run mode.
Signals cannot be output externally.	The trigger signal has not been input.
	The cables are not correctly wired.
	The signal line is disconnected. The status of communications can be checked with the I/O monitor.
	The F250 is not in Run mode.

5-1-4 Serial Interface (RS-232C/RS-422) Errors

Problem	Probable cause
No communications are possible.	The cables are not correctly wired.
	The F250's communications specifications do not match those of the external device.
	The communications mode was not selected under System settings/Communication/Serial . Select Normal , Host link , or Menu in the Communications (Serial) menu. (Normal is no-protocol.) The status of communications can be checked with the I/O monitor.
The Unit operates well initially, but after a while there is no response from the F250.	The reception buffer on the external device (e.g., computer) is full. Check that settings allow the data to be properly received.
Cannot perform menu operations from the computer.	The communications mode was not set to Menu in the System settings/Communication/Serial settings.
Data cannot be saved	<ul style="list-style-type: none"> Are the same communications conditions set for both the external device and the F250? Is flow control turned OFF under System settings/communication/Normal? Refer to the <i>F250 Operation Manual</i>.

5-1-5 Cameras

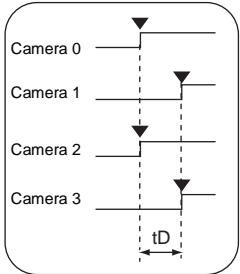
Problem	Probable cause						
Are the shutter trigger pulses synchronized when more than one camera is connected?	<p>The shutter trigger pulses are not synchronized for the F160-S1 and F150-S1. The timing is offset so that light from other Cameras does not enter. The offset depends on the model of Camera that is used.</p> <table border="1" style="margin-left: auto; margin-right: auto;"> <thead> <tr> <th>Model</th> <th>F160-S1</th> <th>F150-S1</th> </tr> </thead> <tbody> <tr> <td>tD</td> <td>Approx. 500 μs</td> <td>Approx. 1 ms</td> </tr> </tbody> </table> <p>If a strobe is used, the strobe trigger signals are also offset in the same way as the shutter trigger pulses.</p> <div style="text-align: right;">  <p>▼ Shutter trigger pulses ON</p> </div>	Model	F160-S1	F150-S1	tD	Approx. 500 μs	Approx. 1 ms
	Model	F160-S1	F150-S1				
tD	Approx. 500 μs	Approx. 1 ms					
	<p>The shutter trigger pulses are synchronized for other Cameras, i.e., there is no offset.</p>						
Can more than one internally synchronized Cameras be connected?	No. Only one F200-S Camera (internal sync) can be connected, and it must be connected to Camera connector 0.						
Can the F150-LT10A Light be connected to the F160-S1 Camera?	<p>Yes, it can be connected and the following Lenses are available.</p> <ul style="list-style-type: none"> Lens with 20-mm field of vision: F150-LE20 Lens with 50-mm field of vision: F150-LE50 						

5-1-6 Memory Cards

Problem	Probable cause
Can either of the Memory Card slots be used?	<p>Only the following two functions have restrictions in the slot that can be used.</p> <ul style="list-style-type: none"> Starting the Setup Menu: Slot 0 only Switching scene groups: Slot 1 only <p>Either slot can be used for all other functions (outputting results to a Memory Card, saving scene data, etc.).</p>

5-1-7 Serial Interface (Ethernet) Errors

Problem	Probable cause
No communications are possible.	A 10 Base-T Crossover Cable is not being used for a 1:1 connection.
	10 Base-T Straight-through Cables are not being used for the 1:N connections.
	Power is not being supplied to the HUB, the settings are incorrect, or the connections are incorrect.
	The personal computer's IP Address and Subnet Mask settings are not correct or the settings are duplicated in another device.
	The F250's IP Address and Subnet Mask settings are not correct or the settings are duplicated in another device.
	The IP Address set for the F250 in the computer's communications software is incorrect.
	The communications mode was set to Normal or Menu in the System settings/Communication/Serial window.
	The status of communications can be checked with the I/O monitor.
	The F250 is being accessed by another computer.
	Communications are being affected by a noise source (such as a power line) that is too close to the F250 or communications cables.
Communications are not set for a TELNET connection (TCP/IP, port 23) in the computer's communications software.	
The Unit operates well initially, but after a while there is no response from the F250.	The reception buffer on the external device (e.g., computer) is full. Check that settings allow the data to be properly received.
The response from the F250 is slow. (It takes too long to transfer data and errors occur.)	The IP Address of the F250 or computer is duplicated in another device.
	Communications are being affected by a noise source (such as a power line) that is too close to the F250 or communications cables.
	The network's communications load is too heavy.
	The computer's processing load is too heavy. (A program that requires a lot of processing capacity is being run simultaneously.)
Cannot perform menu operations from the computer.	The communications mode was not set to Menu in the System settings/Communication/Serial settings.

5-1-8 Cabling Errors

Problem	Probable cause
A recommended OMRON RS-232C cable is not being used.	One of the following OMRON cables can be used. Select a cable that works with the device being connected. Connecting to a PC/AT or compatible computer (9-pin connector) <ul style="list-style-type: none"> • XW2Z-200S-V (2 m) • XW2Z-500S-V (5 m) Connecting to a SYSMAC device (9-pin connector) <ul style="list-style-type: none"> • XW2Z-200T (2 m) • XW2Z-500T (5 m)
Can a commercially available cable be used instead of the R150-VM Monitor Cable?	Yes, as long as it's a pin jack cable (with a yellow connector) for video signal connection.

5-2 Maintenance

5-2-1 Replacing the Light

- The Light will gradually lose brightness over time (about 20% loss after 1,500 hours of use). Replace the Light after about 1,500 hours of use.

- Replace the Light if it is damaged or not fully functional.

F150-SL20A/SL50A

Use the following procedure to replace a Light with the F150-LT10A Light. (The F150-LT10A cannot be connected to the older F150-S1 Camera.)

Removing the Light

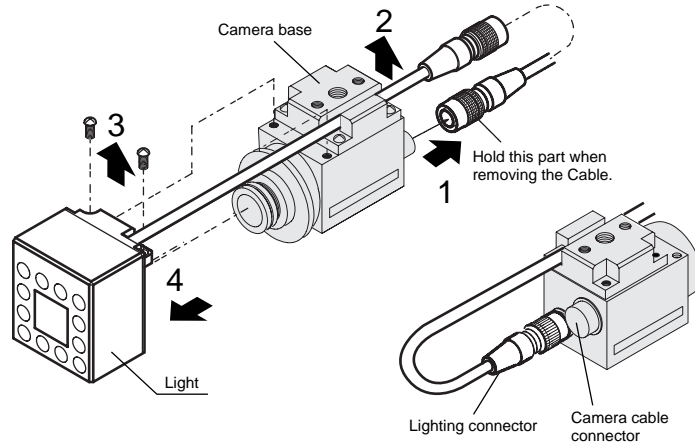

1. Disconnect the light cable from the light connector on the back of the Camera.
2. Remove the light cable from the slot in the camera base.
3. Remove the two screws securing the Light.
4. Remove the Light from the Camera.

Precaution

Do not disassemble the Lens. Disassembly can damage the Lens.

Installing the Light

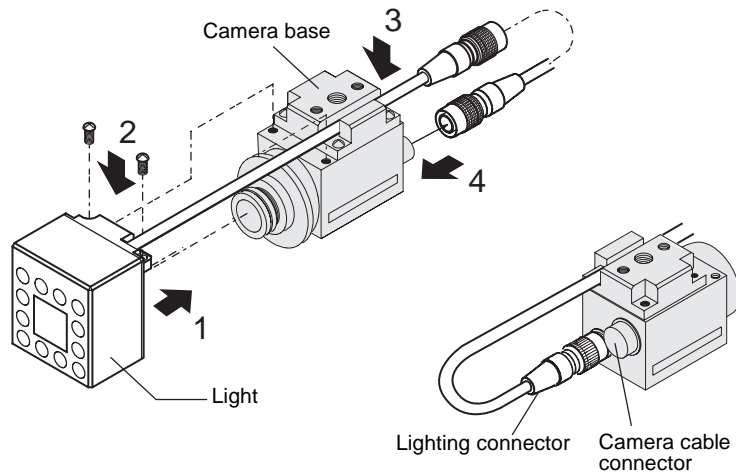

1. Mount the Light on the Camera.
2. Screw in the two screws that secure the Light.
3. Place the light cable in the slot in the camera base.
4. Connect the light cable to the light connector on the back of the Camera.

F150-SLC20/SLC50 or F160-SLC20/SLC50

Use the following procedure to replace a Light with an F150-LTC20 (20-mm field of vision) or F150-LTC50 (50-mm field of vision) Light.

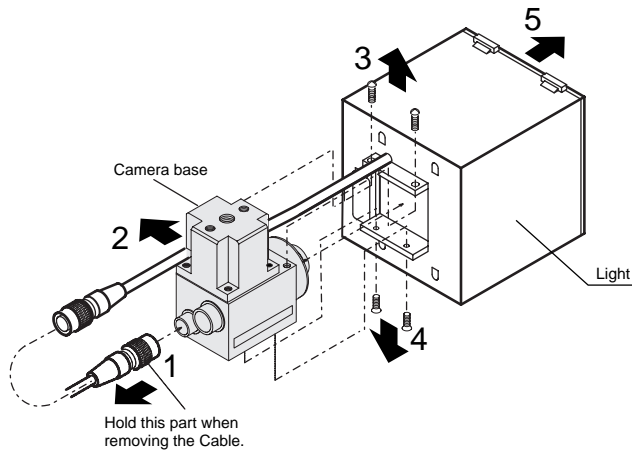
Removing the Light

1. Disconnect the light cable from the light connector on the back of the Camera.
2. Remove the light cable from the slot in the camera base.
3. Remove the two screws securing the Light at the top.
4. Remove the two screws securing the Light at the bottom.
5. Remove the Light from the Camera.

Precaution

Do not disassemble the Lens. Disassembly can damage the Lens.

CHECK

When you want to use the Camera alone without connecting an Intelligent Lighting, use M2 × 3 screws in the bottom of the Camera instead of the long screws removed in step 4. The screws removed in step 3 are not needed.

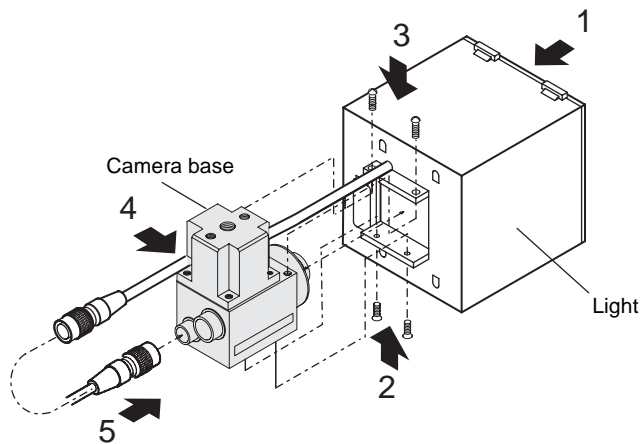
Installing the Light

1. Mount the Light on the Camera.
2. Screw in the two screws that secure the Light at the bottom.
3. Screw in the two screws that secure the Light at the top.

4. Place the light cable in the slot in the camera base.
5. Connect the light cable to the light connector on the back of the Camera.

5-3 Regular Inspections

To maintain the F250 in the best condition, perform the following regularly.

- Clean the Lens and LED indicators with a lens-cleaning wipe or blow off dust with an aerosol air sprayer.
- Lightly wipe off dirt with a soft cloth.

Inspection point	Details	Tools required
Power supply	The voltage measured at the power supply terminals must be 24 VDC $+10\%/_{-15\%}$.	Circuit tester
Ambient temperature	The operating ambient temperature inside the cabinet must be between 0 and 50°C.	Thermometer
Ambient humidity	The operating ambient humidity inside the cabinet must be between 35% and 85%.	Hygrometer
Installation	Each component must be firmly secured. Each cable connector must be correctly inserted and locked. The Cameras must be firmly secured. The camera lens mounts must be firmly secured.	Phillips screwdriver
Indicators	All indicators must light when the power is turned ON. Verify that a through-image is displayed. When using an Intelligent Lighting, verify that the light level settings are set to their maximum values.	---

Precaution

- Turn OFF the power and take safety precautions before conducting inspections. Electrical shock can result from attempting safety inspections with the power turned ON.
- Do not use thinners or benzene to clean the F250. They will damage F250 components.

5-4 Specifications

This section provides the specifications and dimensions of the F250 and its peripheral devices. (All dimensions are in mm unless otherwise noted.)

F250-C50/C55 Vision Mate Controller

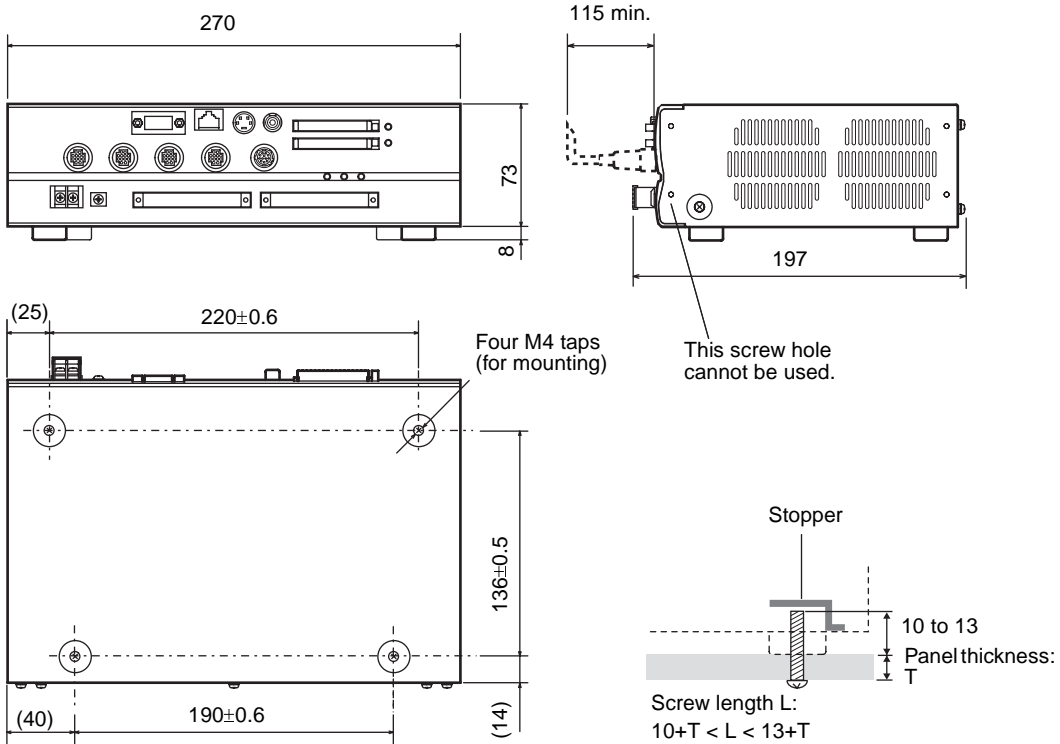

Item	Specification	
Model	F250-C50	F250-C55
Input/Output type	NPN	PNP
Supply voltage	20.4 to 26.4 VDC	
Current consumption	3.0 A max.	
Insulation resistance	20 MΩ min. between all DC external terminals and GR terminal (100 VDC Megger, with internal surge absorber removed)	
Dielectric strength	1,000 VAC, 50/60 Hz between all DC external terminals and GR terminal (with internal surge absorber removed)	
Leakage current	10 mA max.	
Noise resistance	2,000 V; pulse width: 50 ns; rise time: 5 ns (pulse) Burst continuation time: 15 ms; Period: 300 ms	
Vibration resistance	10 to 150 Hz; half-amplitude: 0.1 mm; maximum acceleration: 15 m/s ² , 10 times for 8 minutes each in 3 directions.	
Shock resistance	150 m/s ² , 3 times each in 6 directions	
Ambient temperature	Operating: 0 to 50°C (with no condensation) Storage: -25 to 65°C (with no condensation)	
Ambient humidity	Operating and storage: 35% to 85% (with no condensation)	
Ambient environment	No corrosive gases	
Ground	Class 1 (Ground resistance 100 Ω max.)	
Degree of protection	IEC60529 IP20 (in-panel)	
Case material	SECC-T	

Item	Specification
Battery life	Approximately 7 years when used 24 hours/day.
Weight	Approx. 3.1 kg (Controller only)

F150 Cameras

Cameras with Light

■ **F150-SL20A/SL50A**

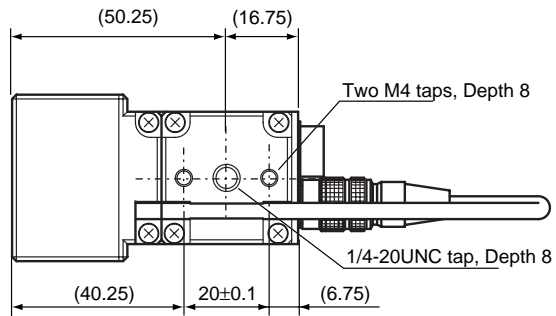
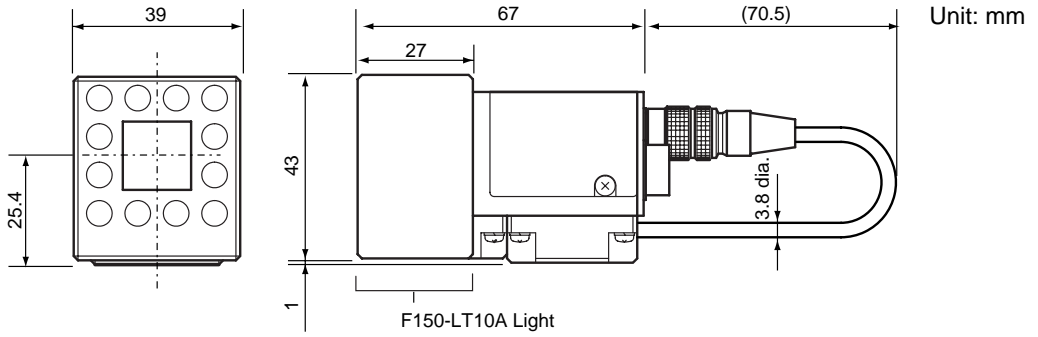

Cameras with Intelligent Lighting

■ F150-SLC20

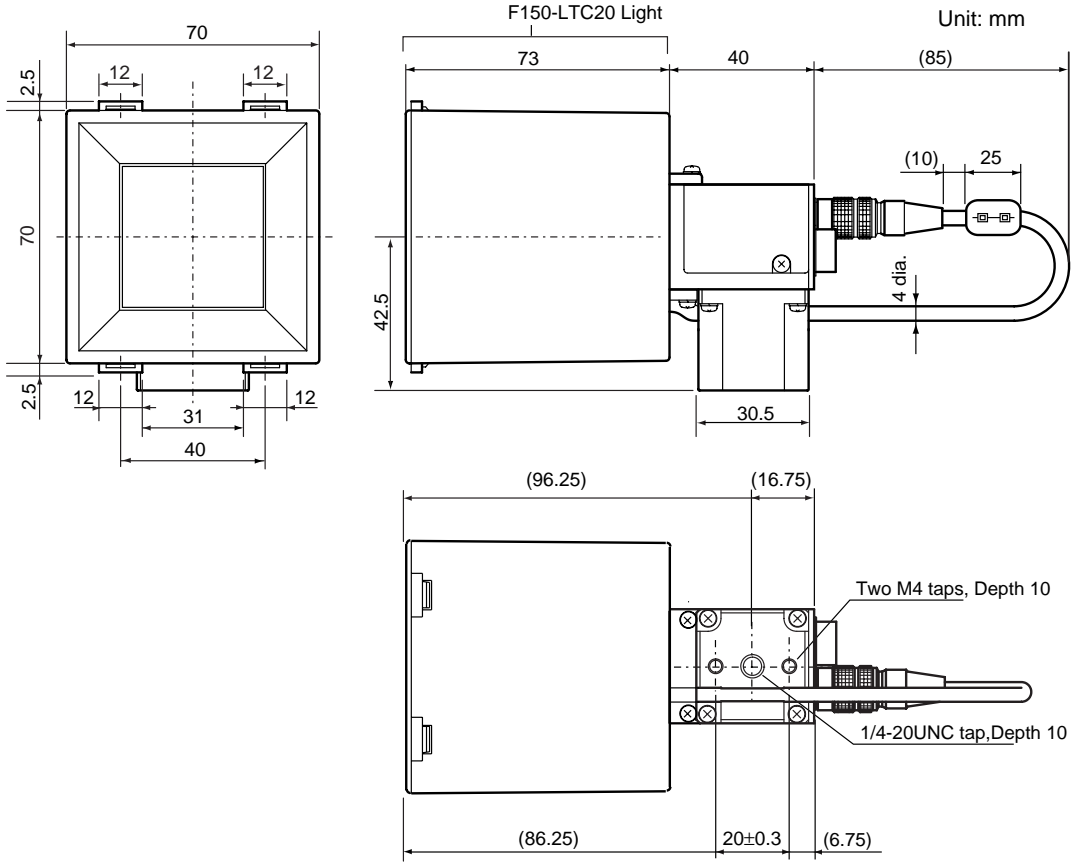

■ F150-SLC50

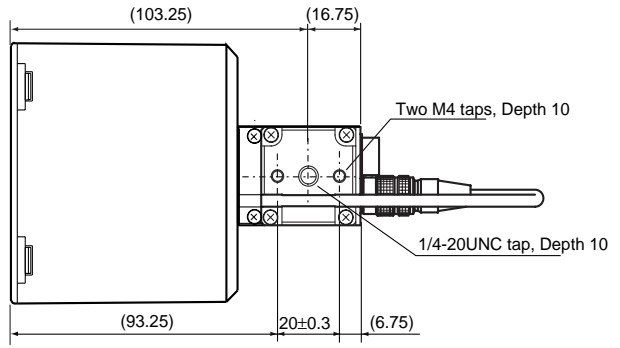
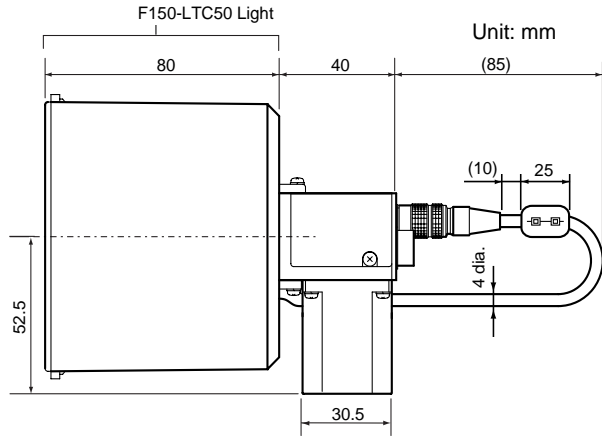
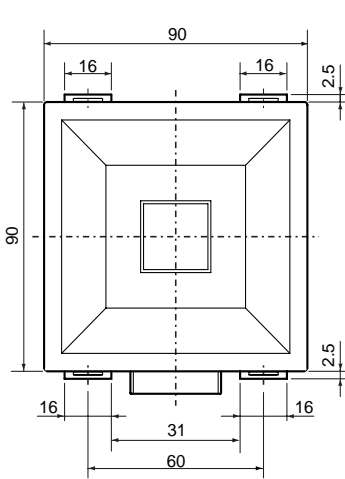

Camera Only

■ F150-S1A

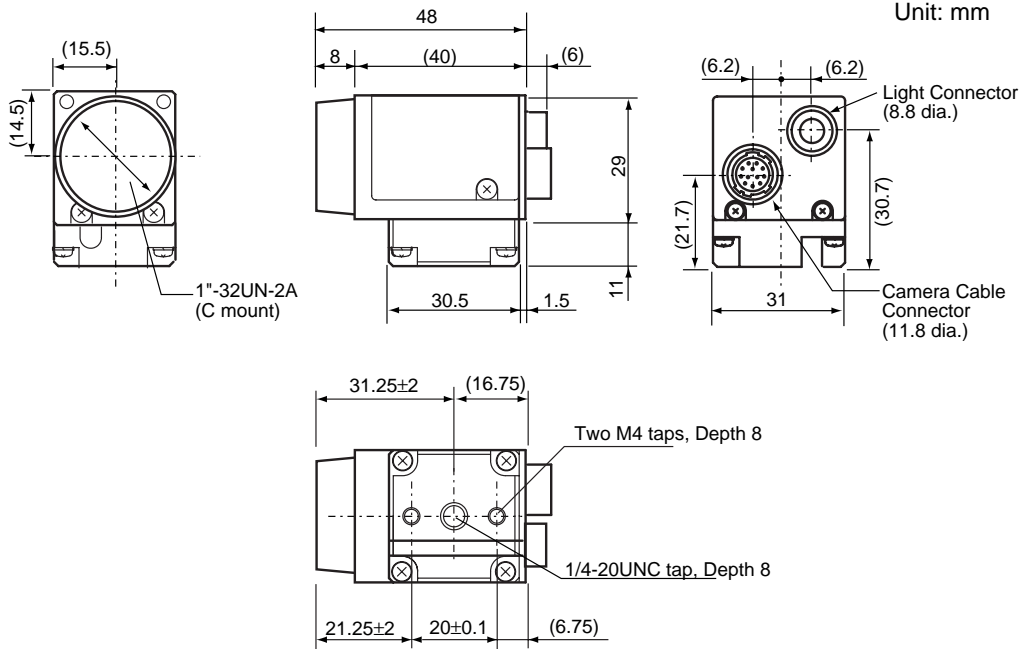

F160 Cameras

Cameras with Intelligent Lighting

■ F160-SLC20

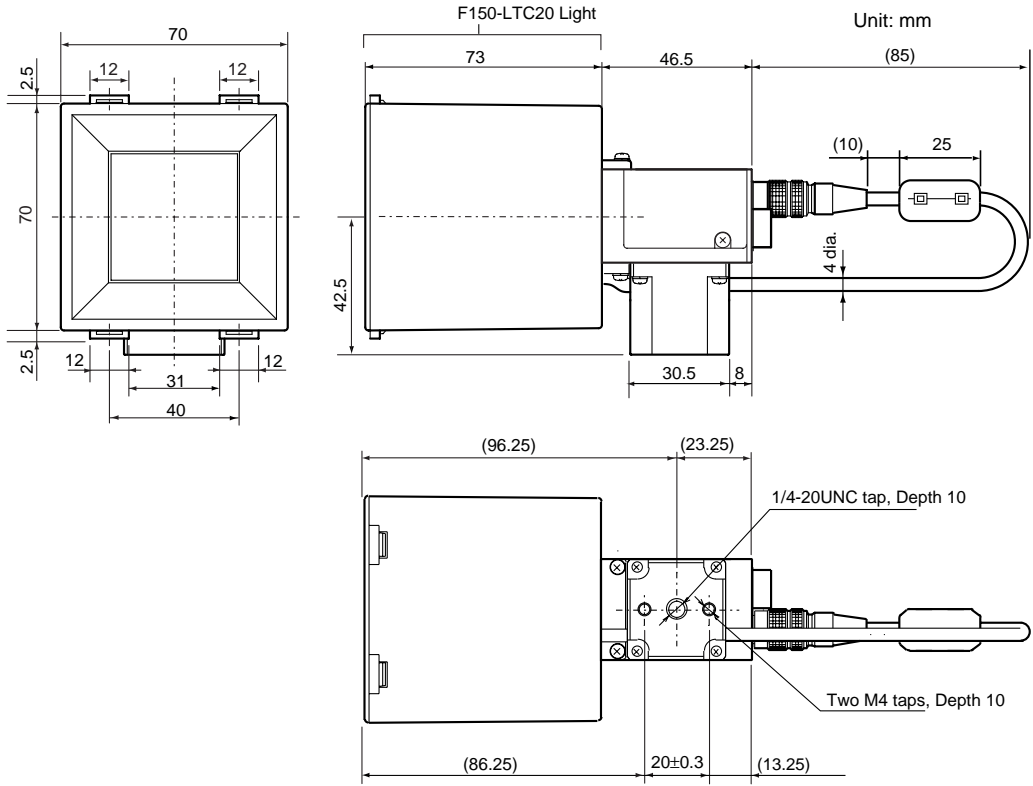

■ **F160-SLC50**

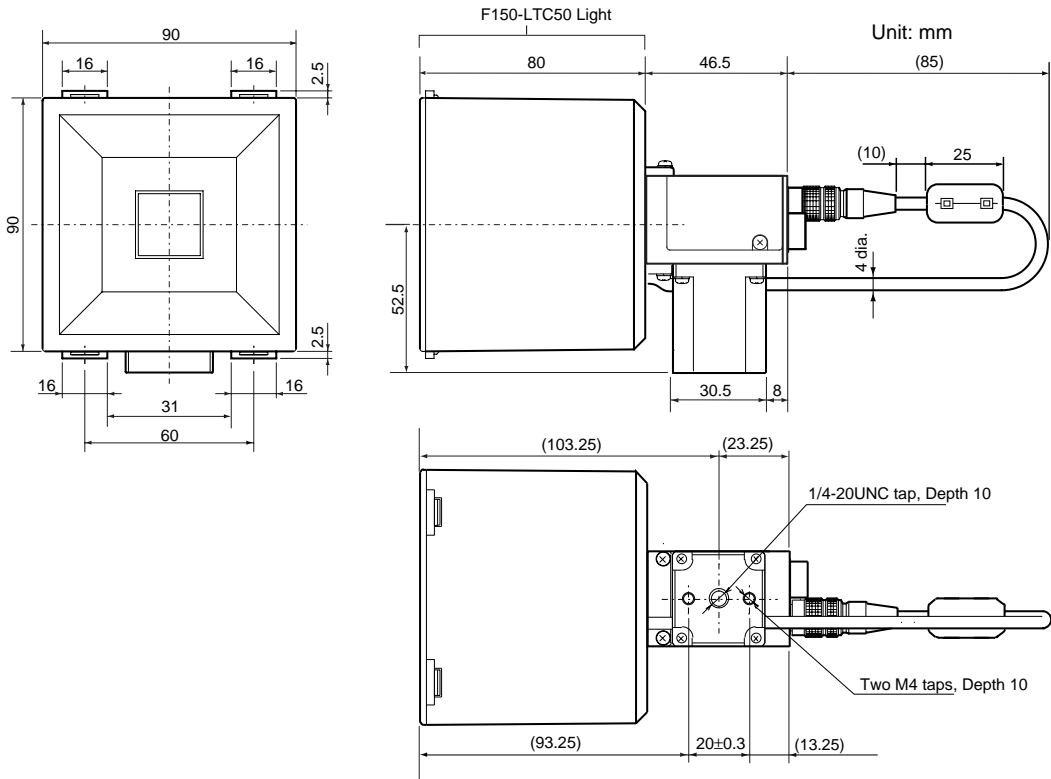

Camera Only

■ **F160-S1**

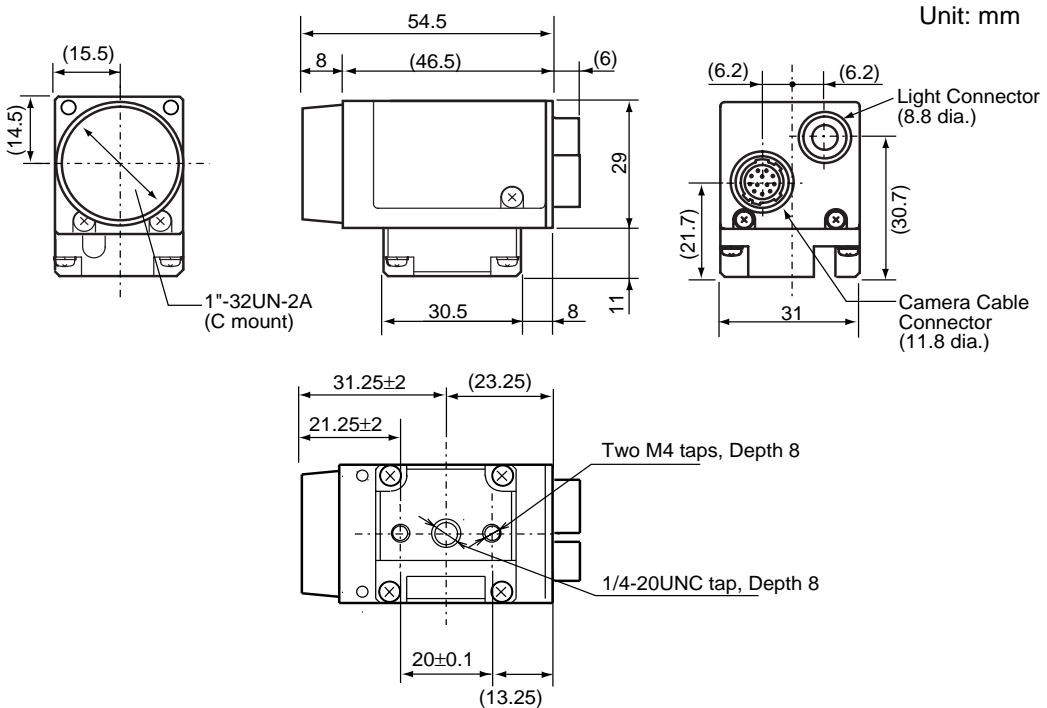

Camera Specifications

General Specifications

Item	Specification
Supply voltage	F150-series: 12 VDC F160-series: 13 VDC
Current consumption	F150-S1A: 100 mA max. F150-SL20A/SL50A: 110 mA max. F150-SLC20/SLC50: 200 mA max. F160-S1: 130 mA max. F160-SLC20: 260 mA max. F160-SLC50: 310 mA max.
Vibration resistance	10 to 150 Hz; half-amplitude: 0.35 mm; maximum acceleration: 50 m/s ² , 10 times for 8 minutes each in 3 directions
Shock resistance	150 m/s ² , 3 times each in 6 directions
Ambient temperature	Operating: 0 to 50 °C (with no condensation) Storage: -25 to 65 °C (with no condensation)
Ambient humidity	Operating and storage: 35% to 85% (with no condensation)
Ambient environment	No corrosive gases
Camera materials	Cover: Galvanized steel sheet metal Case: Die-cast aluminum alloy Camera mounting base: Fiber-reinforced plastic (black)
Light materials (Cameras with Lights)	Case: ABS Transparent cover: PC
Weight	F150-S1A: Approx. 80 g F150-SL20A/SL50A: Approx. 135 g F150-SLC20: Approx. 280 g F150-SLC50: Approx. 370 g F160-S1: Approx. 85 g F160-SLC20: Approx. 285 g F160-SLC50: Approx. 375 g

Characteristics

■ Camera Characteristics

Item	Specification
Picture element	1/3" Interline CCD (reading all pixels)
Effective pixels	659 × 494 (H × V)
Synchronization	External sync. via horizontal sync signal
Shutter speed (Electronic shutter)	F150-series: 1/100 s, 1/500 s, 1/2000 s, 1/10000 s F160-series: 1/120 s, 1/200 s, 1/500 s, 1/1000 s, 1/2000 s, 1/4000 s, 1/8000 s, 1/20000 s
Lens mounting	C mount

■ Lens Characteristics (Cameras with Lights only)

Item	Specification
Lens model	F150-SL20A: F150-LE20 F150-SL50A: F150-LE50 F150-SLC20: F150-LE20 F150-SLC50: F150-LE50 F160-SLC20: F150-LE20 F160-SLC50: F150-LE50
Method	Fixed focal point, fixed iris

Item	Specification
Brightness	F2.8
Focal point distance	F150-SL20A: 13 mm F150-SL50A: 6.1 mm F150-SLC20: 13 mm F150-SLC50: 6.1 mm F160-SLC20: 13 mm F160-SLC50: 6.1 mm

■ Light Characteristics (Cameras with Lights only)

Item	Specification
Light model	F150-SL20A/SL50A: F150-LT10A F150-SLC20:F150-LTC20 F150-SLC50:F150-LTC50 F160-SLC20:F150-LTC20 F160-SLC50:F150-LTC50
Light source	F150-SL20A/SL50A: Red LED (Peak emission wavelength: 680 nm) F150-SLC20/SLC50 and F160-SLC20/SLC50: Red and green LED combination (Peak emission wavelengths: 660 nm and 570 nm)
Light emission method	Pulse emission (synchronized with the camera shutter)

■ Other Characteristics

Item	Specification
Mounting distance	F150-S1A: Depends on lens being used. F150-SL20A: 61 to 71 mm F150-SL50A: 66 to 76 mm F150-SLC20: 15 to 25 mm F150-SLC50: 16.5 to 26.5 mm F160-S1: Depends on lens being used. F160-SLC20: 15 to 25 mm F160-SLC50: 16.5 to 26.5 mm
Field of vision	F150-S1A: Depends on lens being used. F150-SL20A: 20 mm × 20 mm F150-SL50A: 50 mm × 50 mm F150-SLC20: 20 mm × 20 mm F150-SLC50: 50 mm × 50 mm F160-S1: Depends on lens being used. F160-SLC20: 20 mm × 20 mm F160-SLC50: 50 mm × 50 mm

Consoles

■ F150-KP Console

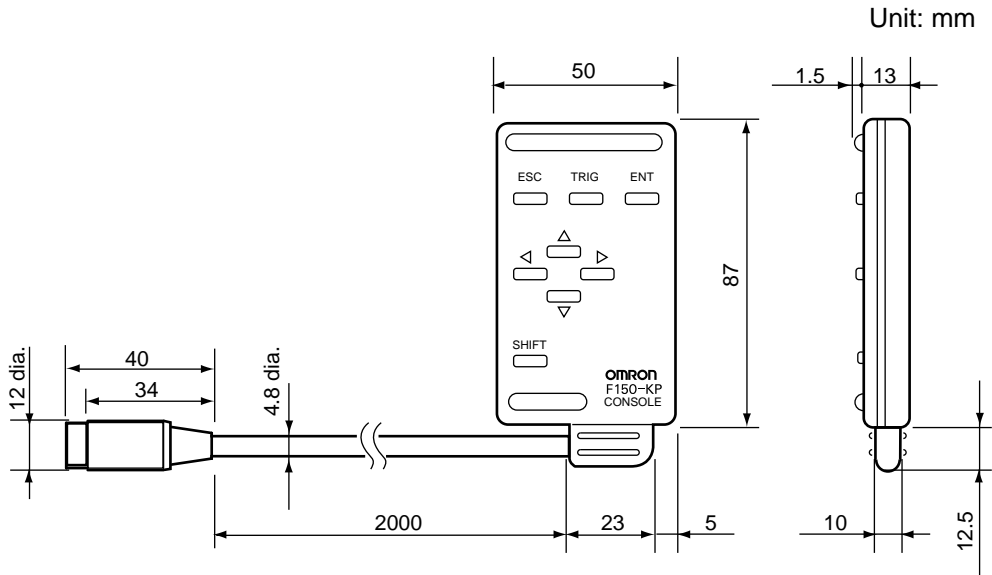

Item	Specification
Vibration resistance	10 to 150 Hz; half-amplitude: 0.15 mm; 4 times for 8 minutes each in 3 directions
Shock resistance	196 m/s ² ; 3 times each in 6 directions
Ambient temperature	Operating: 0 to 50 °C (with no condensation) Storage: -25 to 65 °C (with no condensation)
Ambient humidity	35% to 85% (with no condensation)
Ambient environment	No corrosive gases
Degree of protection	IEC60529 IP20 (in-panel)
Minimum bending radius	75 mm
Materials	Body: ABS Cable sheathing: Heat-resistant chlorinated vinyl Connector: PC and PBT
Weight	Approx. 135 g

■ F160-KP Console

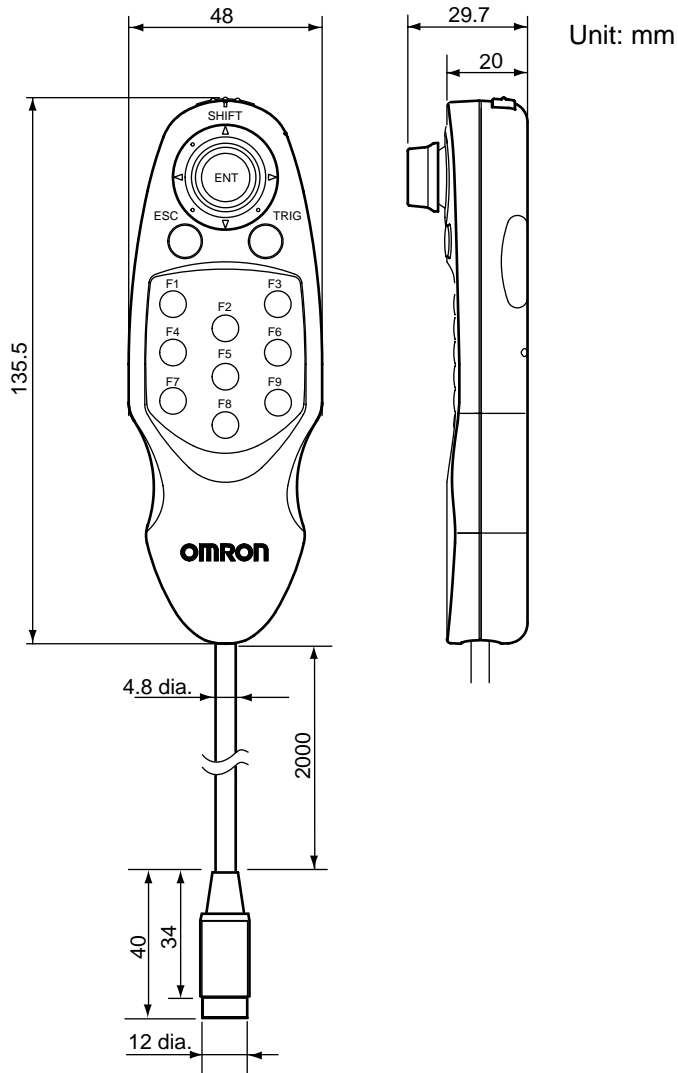

Item	Specification
Current consumption	Approx. 10 mA
Vibration resistance	10 to 150 Hz; half-amplitude: 0.35 mm; maximum acceleration: 50 m/s ² , 10 times for 8 minutes each in 3 directions
Shock resistance	150 m/s ² ; 3 times each in 6 directions
Ambient temperature	Operating: 0 to 50 °C (with no condensation) Storage: -25 to 65 °C (with no condensation)
Ambient humidity	35% to 85% (with no condensation)
Ambient environment	No corrosive gases
Degree of protection	IEC60529 IP20 (in-panel)
Minimum bending radius	75 mm
Materials	Body: ABS Cable sheathing: Heat-resistant chlorinated vinyl Connector: PC and PBT
Weight	Approx. 160 g

CHECK The switch on the back of the F160-KP must be set to "ENABLE".

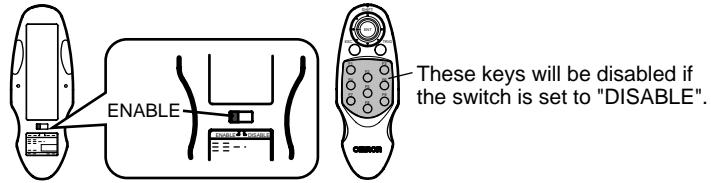

Cables

Camera Cables

■ **Camera Cable Specifications**

The F150-VS, F160-VSR3, and F160-VSR4 Camera Cables have different dimensions and wiring, but they share the same specifications.

Item	Specification
Vibration resistance	10 to 150 Hz; half-amplitude: 0.15 mm, 4 times for 8 minutes each in 3 directions
Shock resistance	196 m/s ² , 3 times each in 6 directions
Ambient temperature	Operating: 0 to 50 °C (with no condensation) Storage: -25 to 65 °C (with no condensation)
Ambient humidity	35% to 85% (with no condensation)
Ambient environment	No corrosive gases
Materials	Cable sheathing: Heat-resistant chlorinated vinyl Connector: Fiberglass-reinforced PC and PBT
Minimum bending radius	75 mm
Weight	Approx. 170 g

■ F150-VS Camera Cable (For F150-S□, F160-S□ Cameras)

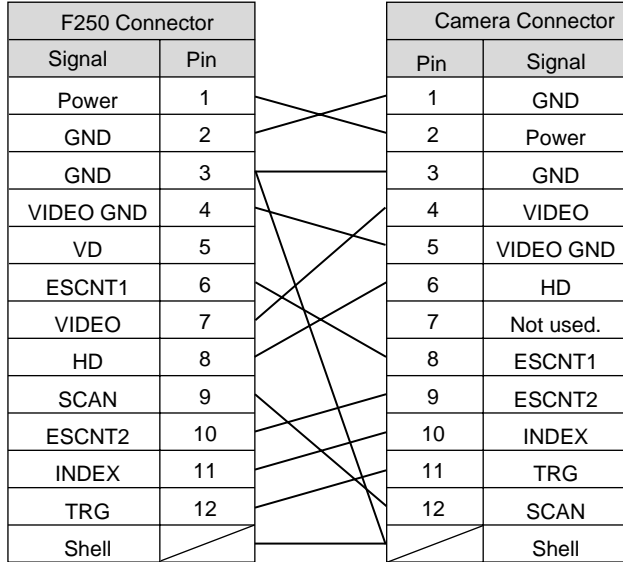
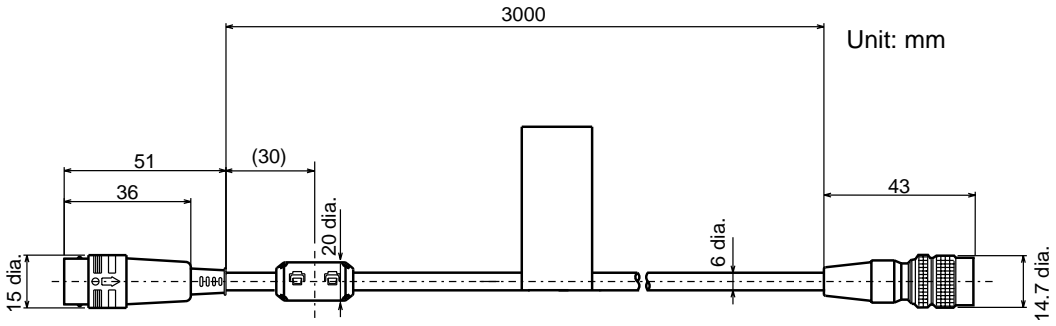

Connector model:
Hirose RP17A-13PA-12PC

Connector model:
Hirose HR10A-10P-12S

F160-VSR3 Camera Cable (For F300-S2R/S3DR/S4R and F200-S□ Cameras)

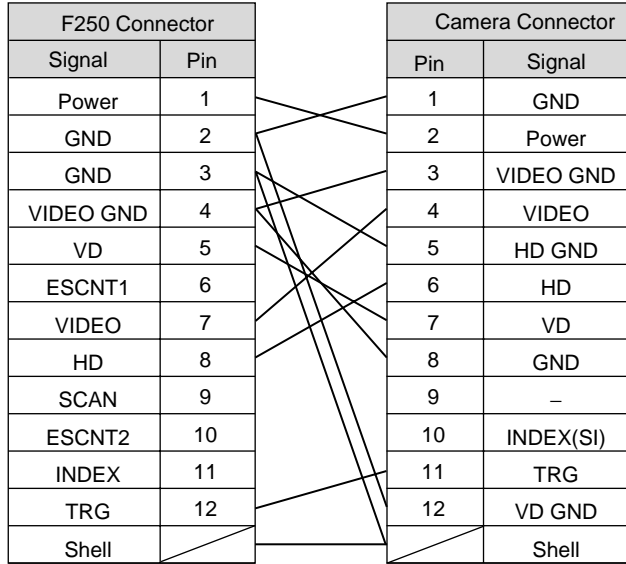
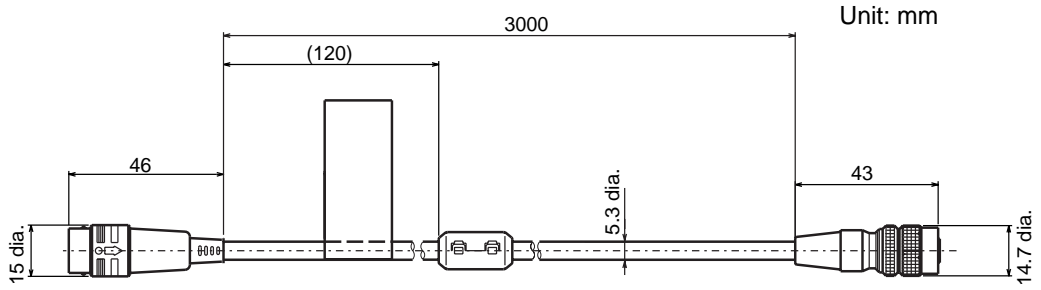

Connector model:
Hirose RP17A-13P-12PC

Connector model:
Hirose HR10A-10P-12S

■ F160-VSR4 Camera Cable (For F300-S Cameras)

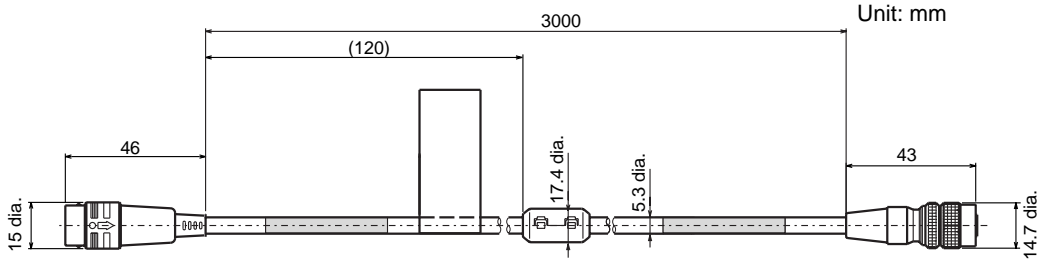

F250 Connector		Camera Connector	
Signal	Pin	Pin	Signal
Power	1	1	GND
GND	2	2	Power
GND	3	3	VIDEO GND
VIDEO GND	4	4	VIDEO
VD	5	5	HD GND
ESCNT1	6	6	HD
VIDEO	7	7	VD
HD	8	8	GND
SCAN	9	9	-
ESCNT2	10	10	INDEX(SI)
INDEX	11	11	Power
TRG	12	12	VD GND
Shell			Shell

Connector model:
Hirose RP17A-13P-12PC

Connector model:
Hirose HR10A-10P-12S

F150-VM Monitor Cable

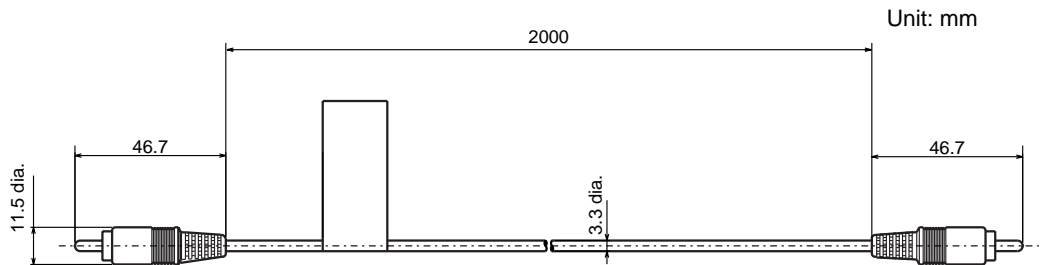

Item	Specification
Vibration resistance	10 to 150 Hz; half-amplitude: 0.15 mm, 4 times for 8 minutes each in 3 directions
Shock resistance	196 m/s ² , 3 times each in 6 directions
Ambient temperature	Operating: 0 to 50 °C (with no condensation) Storage: -25 to 65 °C (with no condensation)
Ambient humidity	35% to 85% (with no condensation)
Ambient environment	No corrosive gases
Materials	Cable sheathing: Heat-resistant chlorinated vinyl Connector: PVC

Item	Specification
Minimum bending radius	50 mm
Weight	Approx. 40 g
Accessories	BNC Jack Adapter

F160-VP Parallel I/O Cable

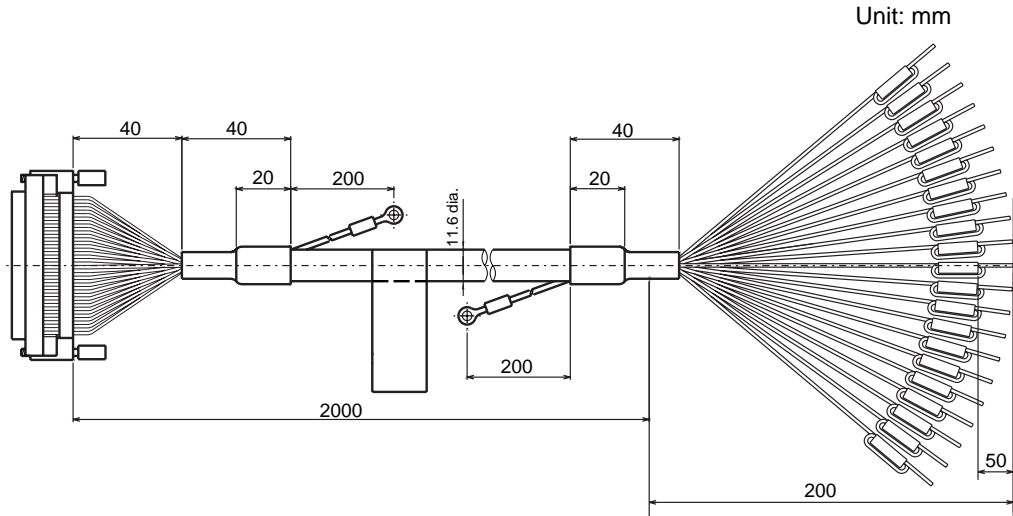

Item	Specification
Vibration resistance	10 to 150 Hz; half-amplitude: 0.15 mm, 4 times for 8 minutes each in 3 directions
Shock resistance	196 m/s ² , 3 times each in 6 directions
Ambient temperature	Operating: 0 to 50 °C (with no condensation) Storage: -25 to 65 °C (with no condensation)
Ambient humidity	35% to 85% (with no condensation)
Ambient environment	No corrosive gases
Materials	Cable sheathing: Heat-resistant PVC Connector: Polyester resin
Minimum bending radius	120 mm
Weight	Approx. 340 g

F150-M05L LCD Color Monitor

Unit: mm

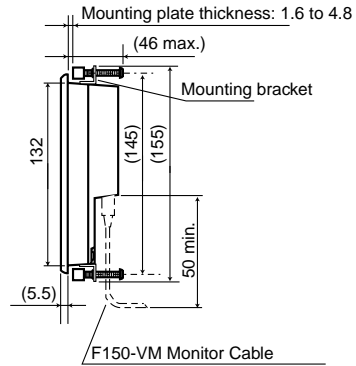
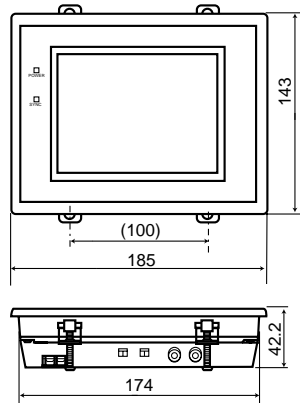

- Tolerance: ± 1 mm

The dimensions in parentheses are provided for reference.

Panel opening dimensions

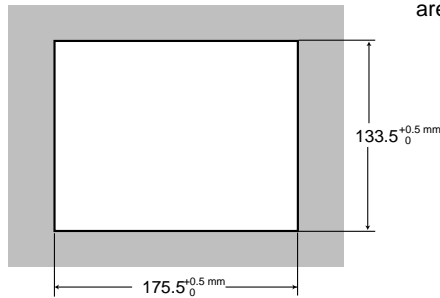

Item	Specification
Supply voltage	20.4 to 26.4 VDC
Current consumption	700 mA max.
Vibration resistance	10 to 150 Hz; half-amplitude: 0.1 mm; maximum acceleration: 15 m/s ² , 10 times for 8 minutes each in 3 directions
Shock resistance	150 m/s ² , 3 times each in 6 directions
Ambient temperature	Operating: 0 to 50 °C (with no condensation) Storage: -25 to 65 °C (with no condensation)
Ambient humidity	35% to 85% (with no condensation)
Ambient environment	No corrosive gases
Degree of protection	IEC60529 IP20 (in-panel)
Materials	Case: ABS/PC Display surface: PMMA (Acrylic)
Panel size	5.5 inches (111.36 × 83.52 mm (H × V))
Panel type	TFT color liquid crystal
Resolution	320 × 240 dots
Image pitch	0.348 × 0.348 mm (H × V)
Contrast	85:1 (typical)
Viewable angle	25° up/down and 50° left/right (with a contrast ratio > 10)
Luminance	250 cd/m ² (typical)
Backlight	Cold cathode fluorescent light
Response speed	60 ms max.
Input signal	NTSC composite video (1.0 V/75 Ω termination)

Item	Specification
Weight	Approx. 1 kg
Accessories	Four mounting brackets

F150-M09 Video Monitor

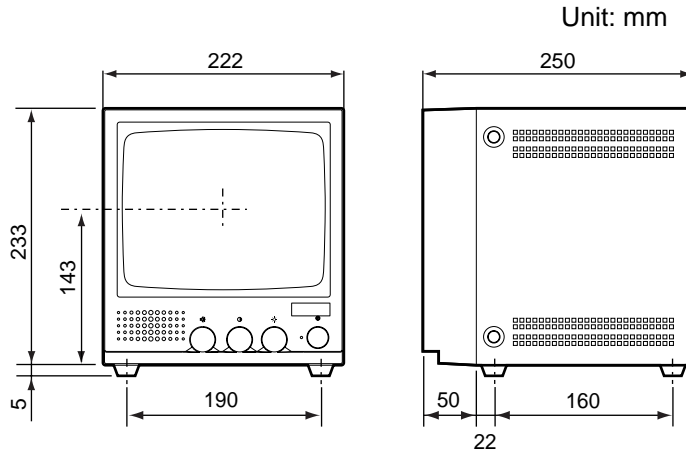

Item	Specification
Supply voltage	85 to 264 VAC, 50/60 Hz
Current consumption	20 W max.
Vibration resistance	5 to 100 Hz; 0.16-mm full-amplitude or acceleration of 7.35 m/s ² (whichever is smaller), 6 times for 10 minutes each in 3 directions
Ambient temperature	Operating: -10 to 50 °C (with no condensation) Storage: -20 to 65 °C (with no condensation)
Ambient humidity	10% to 90% (with no condensation)
Ambient environment	No corrosive gases
Materials	Front: ABS plastic Metal part: SECC (galvanized steel sheet)
CRT size	9 inch (164 × 123 mm (H × V))
CRT type	Monochrome CRT
Resolution	800 TV lines min. (at center)
System	Number of scanning lines: 600 Horizontal frequency: 15.75 kHz Field frequency: 60 Hz
I/O impedance	75 Ω, high impedance (selectable)
I/O level and polarity	Composite image signal: 1 V (peak to peak) Image: 0.7 V (peak to peak), positive Synchronization: 0.3 V (peak to peak), negative
Input signal	NTSC composite video (1.0 V/75 Ω termination)
Weight	Approx. 4.5 kg

Memory Cards

F160-N64S

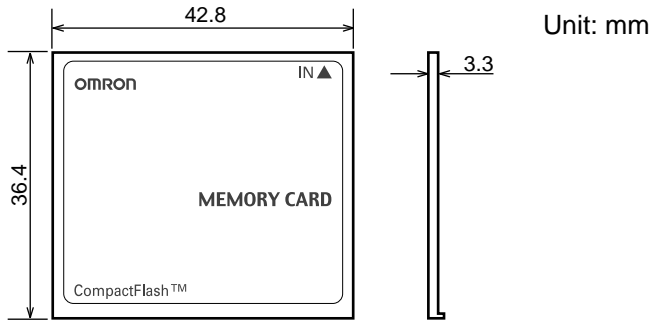

Item	Specification
Ambient temperature	Operating: 0 to 60 °C (with no condensation) Storage: -25 to 85 °C (with no condensation)
Ambient humidity	8% to 95% (with no condensation)
Ambient environment	No corrosive gases
Life expectancy	300,000 overwrite operations
Number of pins	50 pins
Weight	Approx. 15 g

Application Software

F250-UME

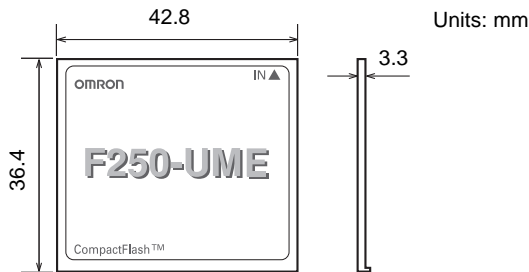

Item	Specification
Ambient temperature	Operating: 0 to 60 °C (with no condensation) Storage: -25 to 85 °C (with no condensation)
Ambient humidity	8% to 95% (with no condensation)
Ambient environment	No corrosive gases
Life expectancy	300,000 overwrite operations
Number of pins	50 pins
Weight	Approx. 15 g

5-5 F200/F300 Camera Parameters

Detailed parameter settings are required when a Camera other than an F150-S1A or F160-S1 is connected. Make the following settings when using an F200/F300 Camera. The **Camera settings** window is displayed at startup and

can be displayed at other times by selecting **Camera settings** from the System Menu.

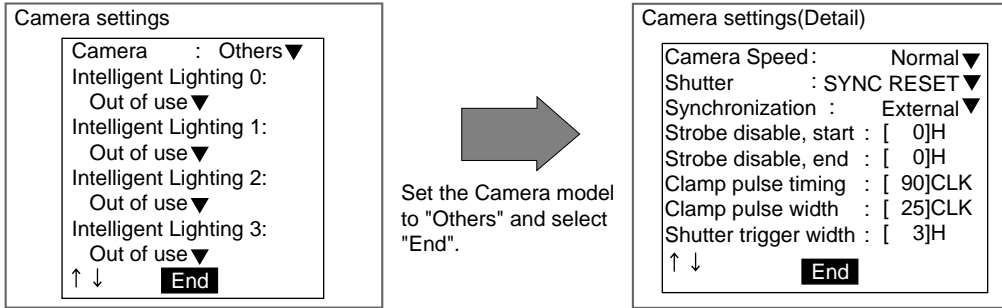

Camera	Camera speed	Shutter	Synchronization	Strobe disable		Shutter speed ¹	Clamp pulse		Shutter trigger pulse		External VD Sync ³	Image read Y timing ³
				Start	End		Timing	Width	Width	Polarity		
F200-S	Standard	OFF	Internal	10	17	(None)	60	20	(Note 2)	Positive	OFF	---
F300-S	Standard	OFF	External	6	8	(None)	90	25	(Note 2)	Positive	OFF	---
F300-S2R	Standard	SYNC NON RESET	External	-8	-6	1/1,000	90	25	7	Negative	OFF	---
				-2	0	1/2,000						
				-2	0	1/4,000						
				-2	0	1/10,000						
F300-S3DR	Standard	SYNC NON RESET	External	-10	-8	1/1,000	90	25	7	Negative	OFF	---
				-2	0	1/2,000						
				3	5	1/4,000						
				5	7	1/10,000						
F300-S4R	Standard	SYNC NON RESET	External	-16	-14	1/1,000	90	25	7	Negative	OFF	---
				-11	-9	1/1,500						
				-8	-6	1/2,000						
				-6	-4	1/3,000						
				-5	-3	1/4,000						
				-3	-1	1/6,000						
				-3	-1	1/8,000						
				-2	0	1/10,000						
				-2	0	1/30,000						
-2	0	1/50,000										

- Note**
1. The shutter speed is set in the Camera itself.
 2. Set the shutter trigger pulse width to match the strobe's specifications only when a strobe is being used.
 3. These settings (indicated by ---) are ignored.

5-6 Connecting a Strobe Device

Use the camera's corresponding strobe trigger output signal (STGOUT0 to STGOUT3) to control the strobe flash timing.

SeeAlso Refer to page 32 for details on the pins allocated to these signals.

Check the strobe device's specifications and set the appropriate "Shutter trigger polarity" and "Shutter trigger width" in the **Camera settings (Detail)** Menu. The **Camera settings (Detail)** window is displayed at startup and can be displayed at other times by selecting **Camera settings** from the System Menu.

Strobe specifications	Shutter trigger polarity	Shutter trigger width
<p>When the flash is synchronized to the OFF-to-ON transition of the strobe trigger signal</p>	Positive	<p>The "shutter trigger width" setting determines the pulse width W.</p> <p>When using a Double-speed Camera: $W = \text{Shutter trigger width setting (H)} \times 32 \mu\text{s}$ (1H = 32 μs)</p> <p>When using a Camera other than a Double-speed Camera: $W = \text{Shutter trigger width setting (H)} \times 63 \mu\text{s}$ (1H = 63 μs)</p>
<p>When the flash is synchronized to the ON-to-OFF transition of the strobe trigger signal</p>	Negative	<p>Note: Depending upon the timing, W may have an error of up to $\pm 1H$.</p>

Combining an OMRON Camera and Strobe

The following table shows the timing polarity. Use a strobe that is compatible with this timing.

Camera	Shutter trigger polarity	Shutter trigger width
F150-S1A	Positive	3H (1H = 63 μs)
F160-S1	Positive	3H (1H = 32 μs)
F200-S	Positive	Can be set to match the strobe's specifications.
F300-S		
F300-S2R	Negative	7H (1H = 63 μs)
F300-S3DR		
F300-S4R		

Note The window used to change the shutter trigger polarity and shutter trigger pulse will not be displayed when an F150-S1A or F160-S1 Camera is connected, but the STGOUT0 to STGOUT3 signals will be output with the polarity and width shown in the table above.

Index

A

ambient temperature, 3

B

battery

- BATTERY LOW message, 5
- replacing, 5

C

cables, 4

Camera Cable specifications, 61

Camera Only, 18

Camera with Intelligent Lighting, 18

Camera with Light, 18

Cameras, 4

- characteristics, 57
- connecting, 17
- overview, 17
- parameters, 68
- specifications, 57

CCTV lenses, 22

communications

- connector, 38
- wiring, 38

components, 4

- installation, 4
- names and functions, 14

computers

- using Memory Cards, 28

connector, 38

Consoles

- connecting, 17
- specifications and dimensions, 59

crimp terminals, 19

D

dimensions, 50

E

Ethernet, 40

Extension Tubes, 24

external devices

- connecting, 29

F

F150 Cameras

- dimensions, 51

F150-KP, 59

F150-M05L, 66

F150-M09, 67

F150-S1A, 54

F150-SL20A/SL50A, 47, 51

F150-SLC20, 52

F150-SLC20/SLC50, 48

F150-SLC50, 53

F150-VS, 62

F160 Cameras

- dimensions, 55

F160-KP, 60

F160-N64S, 68

F160-S1, 56

F160-SLC20, 55

F160-SLC20/SLC50, 48

F160-SLC50, 56

F160-VP, 65

F160-VSR3, 63

F160-VSR4, 64

F250-C50/C55, 50

field of vision, 58

G

ground, 19

I

I/O specifications, 36

inspections, 49

installation

- components, 4
- precautions, 2
- site, 2

L

LCD Monitor, 66

lenses, 22

- characteristics, 57

- diameters, 23

light

characteristics, 58
replacing, 46
lighting, 25

M

maintenance, 46
manuals, ix
Memory Cards, 27
 in personal computers, 28
 removing, 4
 specifications, 68
Monitor
 specifications, 66
Monitors
 connecting, 17
mounting, 15
 distance, 58

N

noise resistance, 4

O

optical chart, 22
orientation, 2

P

package contents
 confirming, 6
parallel interface
 connecting external devices, 30
peripheral devices
 connecting, 17
power supply, 19
 turning OFF, 5
 wiring, 20
precautions, xi
 applications, xii
 battery, xii
 general safety, xii
 installation, 2
 installation environment, xii
 power supply and wiring, xii
products
 availability, 6

R

RESET signal
 precaution, 5
RS-232C, 38
RS-422, 38

S

Screw Terminal Blocks, 31
serial interface
 connecting external devices, 37
signal lines, 4
specifications, 50
 general, 50
 I/O, 36
 Parallel Connectors, 32
strobe
 combining with Camera, 70
 connecting, 70
system configuration, 12

T

temperature
 ambient, 3
troubleshooting, 44
 cables, 46
 connection errors, 44
 menus, 44
 parallel interface, 44
 serial interface, 45

V

Video Monitor, 4, 67

W

wiring
 communications, 38

Revision History

A manual revision code appears as a suffix to the catalog number on the front cover of the manual.

Cat. No. SCHB-736A

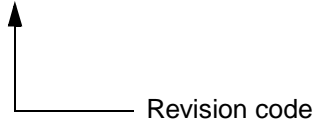

The following table outlines the changes made to the manual during each revision. Page numbers refer to the previous version.

Revision code	Date	Revised content
A	September 2001	Original production

