

Vision Sensor

OMRON

Flagship Model  
FZ3 Series

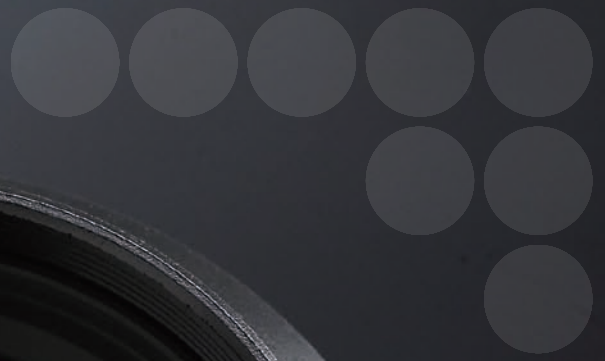

Reproducing it as it is by wide field of vision

5 Million-Pixel Real Color & HDR Sensing

realizing



# Cutting-edge Image Generation

One of the most difficult image processing tasks is the key to solving inspection challenges for factory automation, real color processing, 3D processing and measurement



## Industry-Leading Resolution\*



**5 Million-Pixel Camera**

**Achieving high-precision measurement never before possible** ▶P4

It enables more precise inspections by measuring high-resolution images taken by the camera with an advanced image-processing algorithm.



\*2448x2044pixels

## Landscape format(5200-pixel length)



Patent Pending

**Panorama Image Processing**

**The Vision Sensor's wider fields of view enable inspections for whole workpieces.** ▶P5

Wider fields of view can be achieved by synthesizing the images of two or more cameras. Each synthesized image can be inspected as a single image.



\*Approximately 5200 pixels maximum

\*The images of four 2 million-pixel cameras overlap each other at their edges, with each overlapping area covering 25% of the entire area of each image.

# Technology ... Making it possible!

generation of images most appropriate for individual inspections. Believing that the mastering of image processing is the OMRON has put a number of new technologies into practical use. These new technologies are now combined with OMRON's technologies to allow solutions never before possible.

## 5000 times Dynamic Range



Patent Pending

### High Dynamic Range Function

#### Fundamental solution for difficult lighting settings ▶P6

The conventional difficulty in setting and adjusting lighting conditions is ascribed to the limited dynamic ranges of cameras. FZ3 has achieved a high dynamic range, 5000:1 maximum. This HDR function solves existing problems in setting for lighting.



Ordinary Camera Image



HDR Processed Camera Image

## Image Distortion Correction



Patent Pending

### Trapezoidal Distortion Correction

#### Minimizing the effect of the carrying process or the camera position. ▶P8

You don't need to minimize the effect of flutter in the carrying process or an error in the camera position by trying to improve the hardware aspect of your system any longer.

#### 3D Position Correction

Perspective distortions can also be corrected.

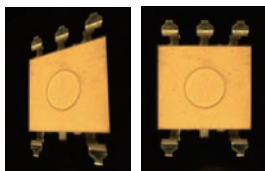

Before correction After correction

#### Cross Shots

Cross shots taken by a camera mounted at an angle on the production line can be inspected with a high degree of precision.

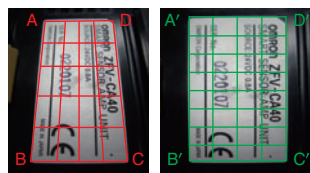

Before correction After correction

Patent Pending

### High-speed Halation Prevention Filter ▶P9

Specular reflection that causes halation can be removed by analyzing the wavelength of the light. Halation-free images can be generated even if workpieces are positioned irregularly.

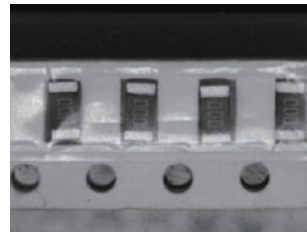

Before processing

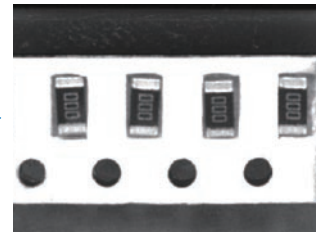

After processing

### Fringe-killer Filter ▶P9

FZ3 eliminates the background patterns, which disturb the detection of defects, for more stable inspections.

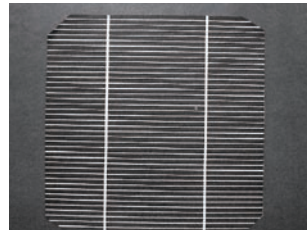

Before processing

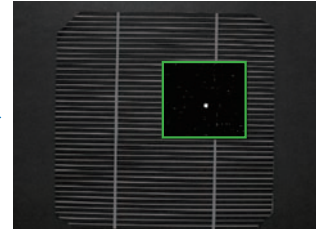

After processing

### The Industry's Fastest CPU ▶P4

The Vision Sensor's processing speed, double that of its predecessor, enables high-speed processing of large-volume data.

### Lineup of 14 Different Cameras ▶P10

The wide variation of cameras, including the industry's smallest pen-shaped camera and a slim camera, allows you to deal with different inspection needs under different conditions.

### 60 Processing Items ▶P12

FZ3 performs approximately 60 processing items, including highly advanced image processing, to meet various inspection needs.

Patent Pending

### Real Color Sensing ▶P13

The Vision Sensor processes 256 gradations of each of the RGB colors as it is. It detects color edges of similar colors and small defects showing little color contrast.

### Evolved New Flow Menu ▶ P16

OMRON's carefully designed, highly user-friendly Flow Menu allows efficient operation from programming to installation, and contributes to man-hour reduction.

# High Resolution Image Generation ... Making it



## Higher Resolutions and Wider Fields of Vision

The Industry's Highest Resolution

### 5 Million-Pixel Cameras

The new 5 million-pixel cameras allow high precision appearance inspections and measurements that cannot be handled by conventional 2 million-pixel cameras.



Color Type  
FZ-SC5M



Black and White Type  
FZ-S5M



5 million pixels  
(2448x2044 pixels)

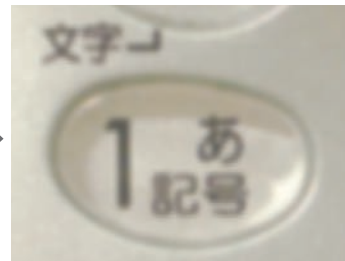

2 million pixels  
(1600x1200 pixels)

### 1.5-times wider field of vision



Even a large workpiece can be imaged at one time and the details are very clear

### Reducing Tact Time

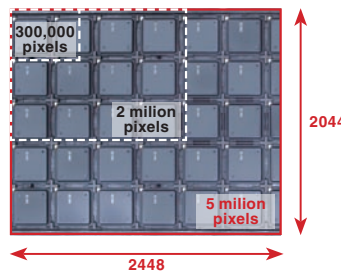

FZ3 takes a single wide-view image of a large workpiece used be imaged in multiple pieces and thus reduces inspection tact time.

### Reducing Set-up Time

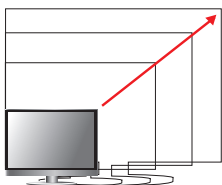

Thanks to the cameras' wider fields of vision, you don't have to move their positions during set up on a production line for different products in different sizes.

### Making Invisible Defects Visible

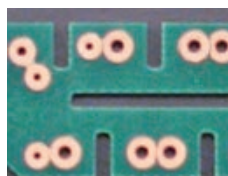

2 million pixels

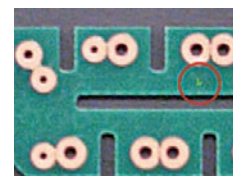

5 million pixels

The improved resolution of the system's cameras allows you to detect very slight defects that were impossible for its predecessor to catch.

### The industry's fastest CPU and latest P.B.S. architecture enable high-speed processing of 5 million-pixel images.

With a high resolution of 2448 x 2044 pixels, our 5 million pixel camera boasts high-speed image capturing at 16 fps (62.5ms). Furthermore, images imported to the controller are processed with our Mega ARCS Engine featuring the industry's fastest CPU and the latest version of P.B.S. architecture. Other than performing advanced image processing tasks and taking images by the 5 million pixel camera both characterized by a high volume of computation, the Vision Sensor processes images of a 2 million pixel or 3 million pixel camera at a much faster speed.

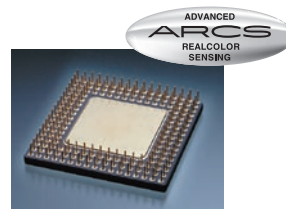

Featuring Mega ARCS Engine

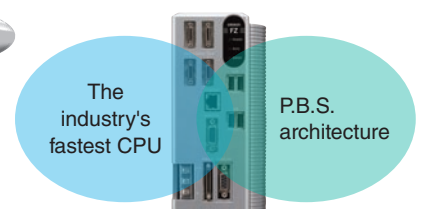

The industry's fastest CPU

P.B.S. architecture

\*P.B.S.: Processing Boost Software

# possible!



**Patent Pending** **Precise Inspections of Large Workpieces in Whole**

**First in the industry** **Ultra-Wide Panorama Image Processing**

When taking images of a large workpiece in multiple pieces using two or more cameras, a conventional vision sensor processes the images taken by the cameras separately in order to secure a satisfactory level of resolution. FZ3's panoramic image processing<sup>\*1</sup> capability allows the measurement of a large or long workpiece in whole by synthesizing the images taken by camera and generating a single image from them.

### Wide Panorama

Images taken by two to four 2-million-pixel cameras are put together like a line camera to generate a single image as if it is taken by a single camera when inspecting a horizontally long workpiece.

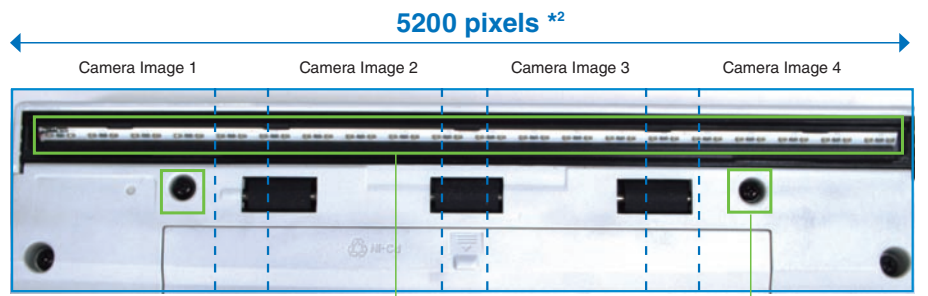

An inspection area can be specified across the images taken by two or more cameras.

The position of the inspection area can be adjusted based on the overview image.

### Synthesis of up to four images

Up to four images can be synthesized horizontally and vertically in accordance with the shape of the workpiece.

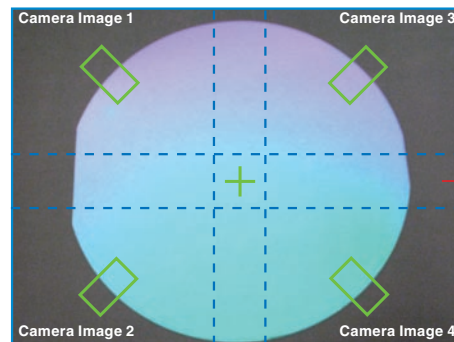

The position of the workpiece is measured based on the overview image.

### Seamless Matching Technology Enabling Panorama Image Processing

Unlike simple image synthesis processes, Omron's innovative Seamless Matching Technology automatically searches the corresponding points in two or more images and synthesized them into one image based on such points. This technology also features an original image processing algorithm that reads out differences attributed to the positions of the cameras based on such corresponding points and automatically calibrate them. As a result, you can generate a perfect seamless image as if it is taken by a single camera.

#### Automatically Matching Corresponding Points

Searching overlapping areas

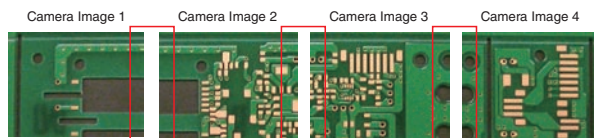

Analyzing each area carefully and searching characteristics such as edges

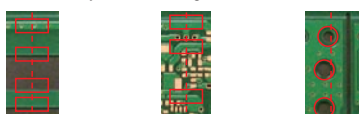

Choosing the most certain characteristics as corresponding points and matching them  
Generating a seamless single image



#### Calibrating Differences in Imaging Conditions

Choosing a benchmark image

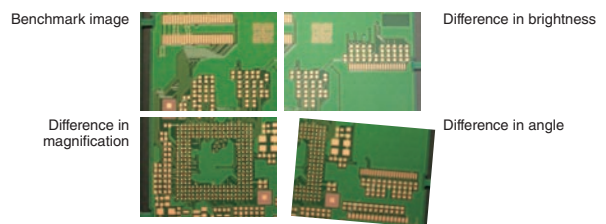

Automatically calibrating differences in brightness, magnification and angle to generate a single image

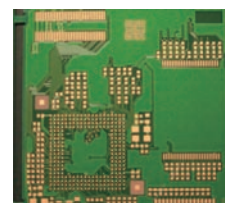

\*1 This feature can be performed with cameras of 2 million pixels or less.

\*2 The images of four 2 million-pixel cameras overlap each other at their edges, with each overlapping area covering 25% of the entire area of each image.

# Original HDR Technology ... Making it possible!



**Patent Pending** No Need for Lighting Techniques

**First in the industry** High Dynamic Range Function

FZ3's high dynamic range minimizes the effects of lighting such as halation and allows highly precise inspections.

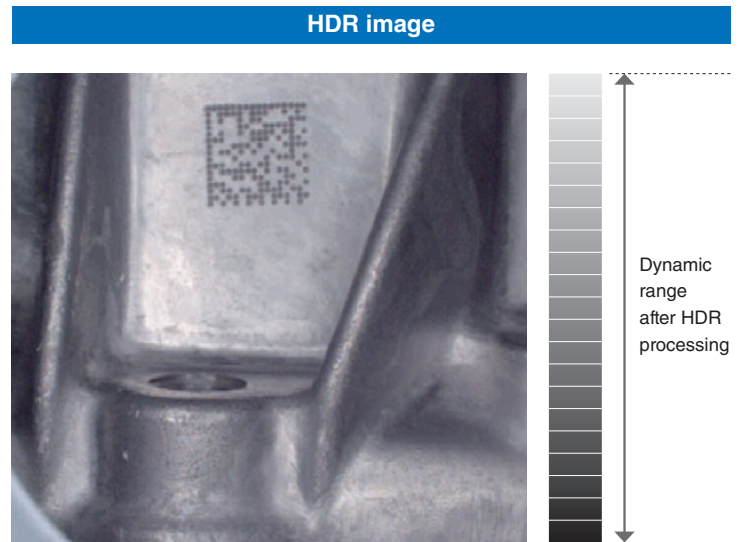
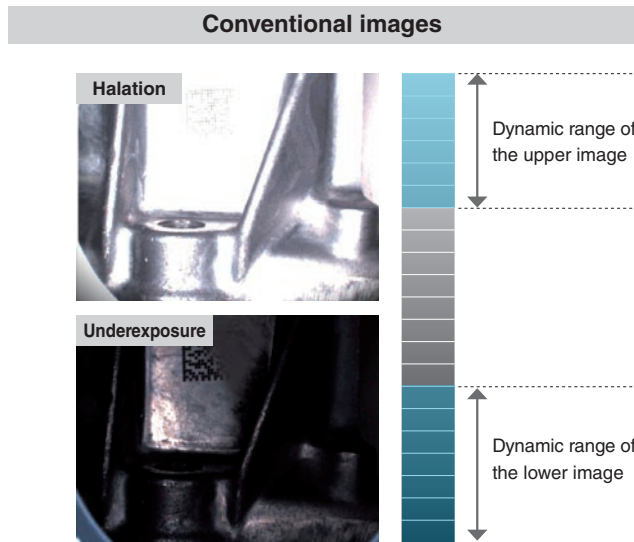

**Defects Undetectable Due to Overexposure or Underexposure**

Any spot outside the dynamic range is blurred by halation or shadow.

**Defects Detectable Even on Reflective or Shadowy Surfaces**

The surface of the workpiece is accurately reproduced and detected even with overexposure or underexposure.

**Reflective and shadowy areas can be reproduced simultaneously under the same lighting conditions.**

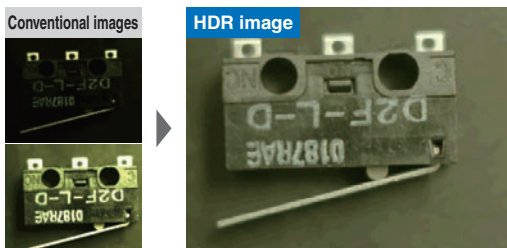

**The reflective surfaces of cylindrically-curved workpieces in which conventional vision sensors have had difficulty can be reproduced.**



**The surfaces of metal workpieces can be reproduced accurately.**

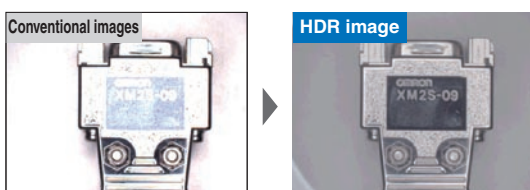

**The influence of changing lighting conditions from day to night are effectively minimized.**

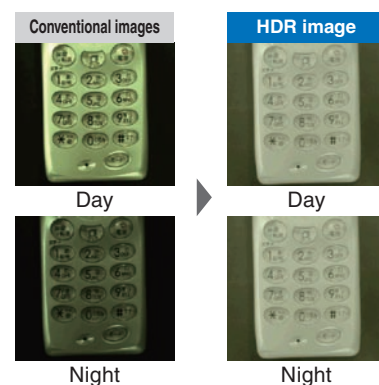



The industry's highest dynamic range

### HDR Image Generation Technology

Dynamic range means the imaging hardware's ability to tell differences in luminosity. The higher dynamic range the hardware scores, the clearer images it can generate when imaging objects with a strong contrast in luminosity. Featuring the HDR Image Generation technology, FZ3 can take two or more images of a workpiece at different levels of luminosity by automatically changing its shutter speed and synthesizes them into a single image rapidly. With this technology, the Vision Sensor has achieved a dynamic range higher than that of any other camera for factory automation use.

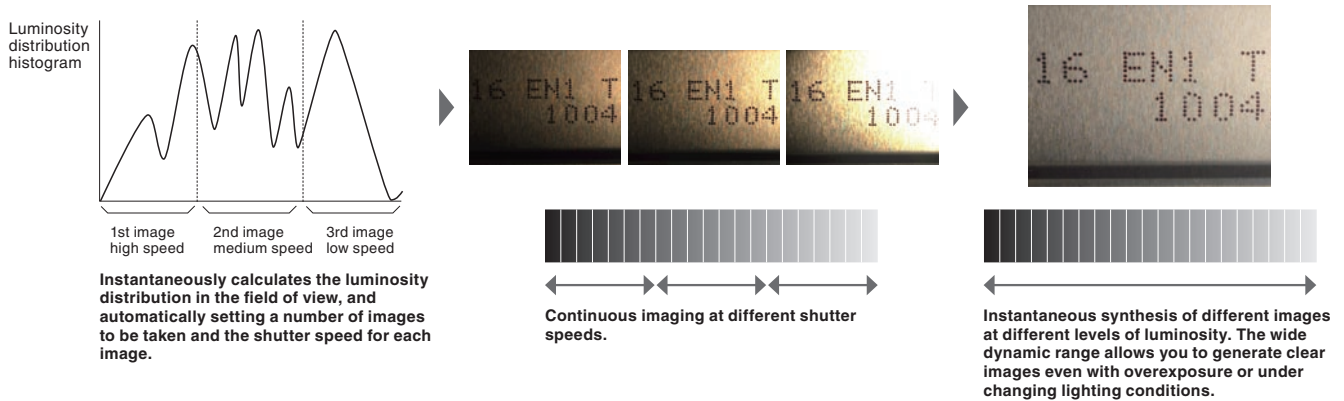

Featuring the industry's first integrating function

### HDR High-Contrast Mode

In the high-contrast mode, FZ3 enhances the contrast in the area to be inspected by overlapping and synthesizing two or more images taken at the same shutter speed. After the synthesis, noise contents are suppressed while the area to be inspected is amplified by integration.

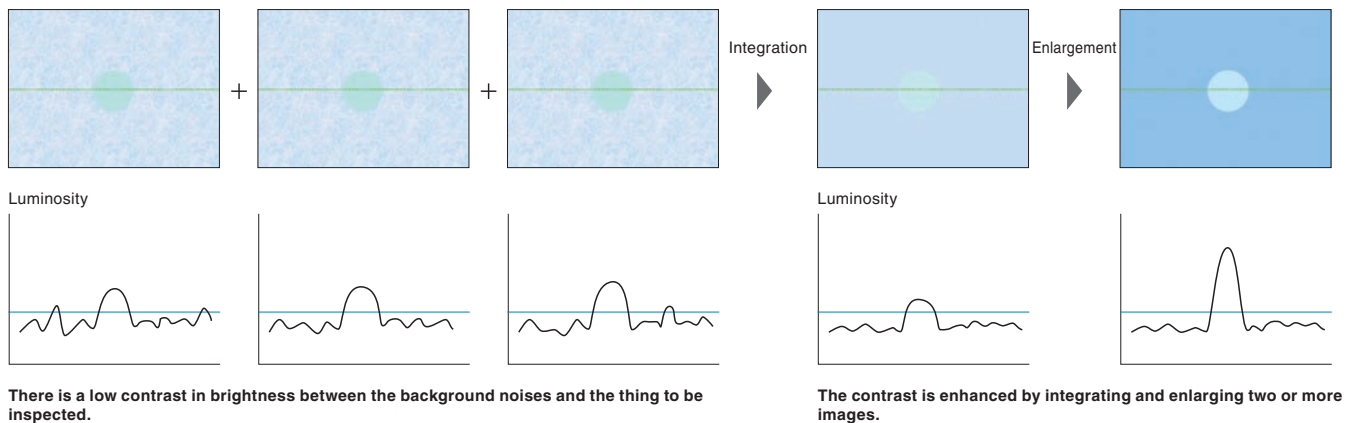

# Real-time Image Generation Technology ... Optimum



**Patent Pending** Minimizing the effects of the camera position or flutter during the carrying process

**First in the industry** Trapezoidal Distortion Correction

Correcting distorted images shot from an angle.

High-precision inspections are ensured even when images are taken from an angle or the carrying process is unstable.



Before processing



After processing

## Cross Shots

### Cameras can be mounted at any angle

FZ3 allows space-saving line designs since cameras can be mounted in any small spaces at any angle. Furthermore, you would have no difficulty in finding appropriate spaces for an additional camera for an additional inspection item.

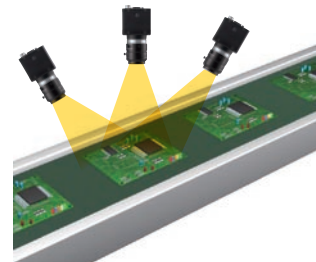

## 3D Position Correction

### Coping with any flutter in the carrying process

High-precision inspections are ensured even when there is flutter in the carrying process. Unlike the conventional vision sensors, FZ3 can also correct perspective distortions.

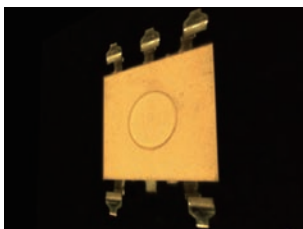

Before processing

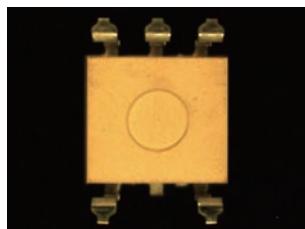

After processing

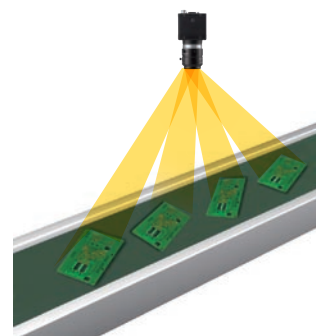

## Patent Pending Trapezoidal Distortion Correction Algorithm

The algorithm specifies four arbitrary points on an image of the workpiece, scales up or down the image locally, and corrects the distortion.

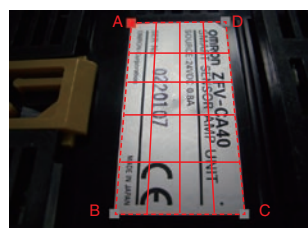

Specifying four points on the image

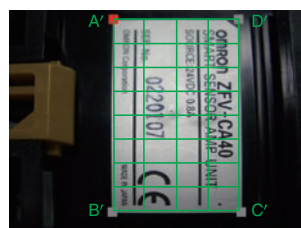

Correcting the distortion of the image based on the four points

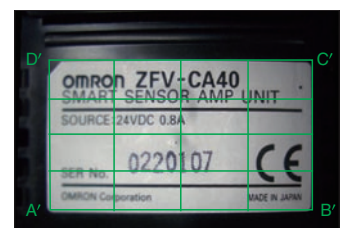

Making an additional correction in any direction



# for Inspection



## Patent Pending **Eliminating reflection of light on the surfaces of moving workpieces**

### First in the industry **High-speed Halation Prevention Filter**

This feature detects blurs caused by halation or unstable lighting, and automatically make corrections. It is very useful when workpieces to be inspected are moving at a high speed or inspections are made through a transparent film.

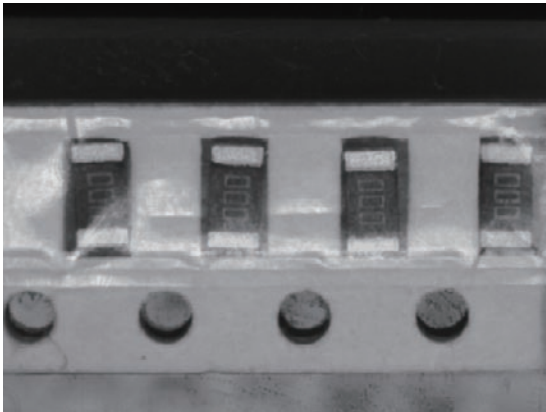

Before processing

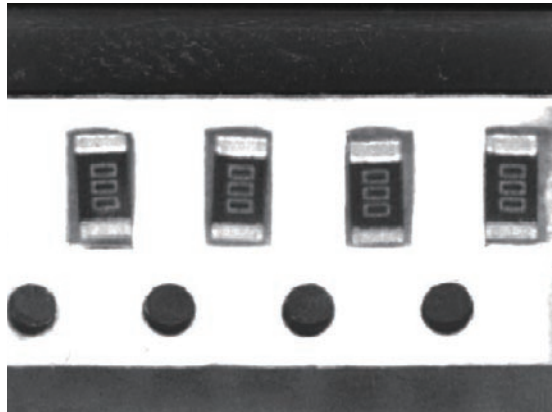

After processing

### Halation Prevention Algorithm

Halation occurs when light reflects in the specular direction toward the camera. Using this characteristic of light, FZ3's Halation Prevention Algorithm automatically filters color images including pixels that decrease the wavelength of specular light and generates halation-free monochrome images.

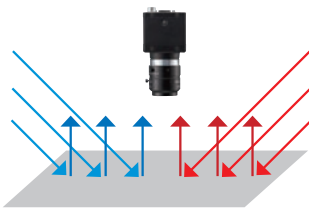

Putting light on different wavelengths from different angles



Analyzing the color elements captured as specular light (halation)



Automatically choosing the most appropriate filter to prevent halation and generating images most appropriate for inspections

A camera with illumination for halation prevention (FZ-SZCRB7018BR-4S) is available.

## Removing fringes to detect defects

### First in the industry **Fringe-killer Filter**

Other than detecting defects by subtraction, FZ3 can also remove some peculiar patterns such as fringes in the background for more stable inspections.



Before processing



After processing

Analyzing images by subtraction and detecting only subtle changes as defects



Conventional images



Image processed by the Fringe-killer Filter

The filter removes fringes in the background and detects defects only even when fringes is as big as defects.

Removing horizontal, vertical and lattice fringes

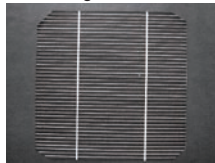

Before processing

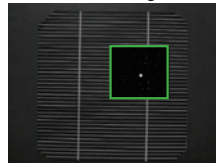

After processing

FZ3 can choose the type of fringes to be removed in accordance with the background of each workpiece to be inspected.

Largest collection in the industry

# 14-type of Camera Lineups ... According to the problems

Contributing to the downsizing of your production facility

## Smallest in the industry Ultra-compact Pen-shaped Camera / Ultra-slim Flat Camera

Our high-performance, high-speed 300,000-pixel cameras have been remarkably downsized. They can be installed in spaces which are too small for conventional cameras.



Full-scale Photo

**Color** FZ-SPC  
**Black & White** FZ-SP



Full-scale Photo

**Color** FZ-SFC  
**Black & White** FZ-SF

### Most compact and shortest pen-shaped camera in the Industry

Suitable for use in narrow spaces

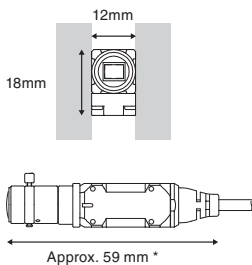

\*This is the size with nothing other than a lens (FZ-LES3).

### First slim flat camera in the Industry

Suitable for use in spaces with little depth that usually require mirrors

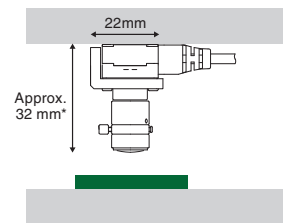

\*This is the size with nothing other than a lens (FZ-LES3) and does not include a spacer for installation.

## Highest resolution in the industry

### 5-million-pixel-camera

▶ P4



**Color** FZ-SC5M  
**Black & White** FZ-S5M

## High resolution and high speed at the same time

### Fastest in the industry

### High speed and high precision

### 2-million-Pixel camera

This high-resolution 2-million-pixel camera (1600 × 1200 pixels) boasts the fastest image capture speed in its class. It is equivalent to the speed of 300,000-pixel cameras. Furthermore, the camera can capture 1-million-pixel images (1600 × 600 pixels) at a speed of 60 fps in the partial capture mode.



**Color** FZ-SC2M  
**Black & White** FZ-S2M

### High speed image capturing of 30 fps

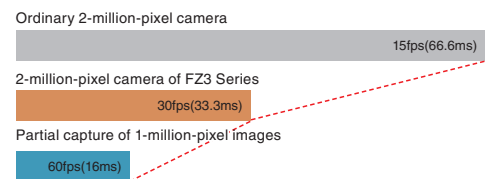

Balancing compactness, high speed and cost performance

## Fastest in its class 300,000-pixel Ultra-high-speed Camera



**Color** FZ-SC  
**Black & White** FZ-S

This camera achieves an image capture speed of 80 fps with full VGA resolution of 640 × 480 pixels, saving input time about 4 ms. It features high speed with highest cost performance. Furthermore, it allows faster image capturing in the partial capture mode.

### High speed image capturing of 80 fps

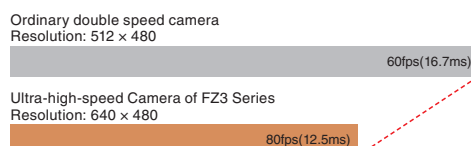

### Partial capture function

This function allows you to specify any part of the workpiece and capture images thereof at a faster speed. Image capturing at a speed of 3 ms maximum is possible.





Achieving prompt setting for mixed production lines

**Patent Pending Autofocus Camera / Intelligent Camera with illumination**

**Remote control of inputting image**

You can remotely control the focus, aperture, field of vision and lighting of the camera installed at a distance from the controller. Once you store the settings for a task, you can reproduce the same input conditions whenever necessary. This function allows you to apply such conditions to other lines and enables prompt setting for each task. The camera also automatically calculates the most appropriate values and reduces setting variation among individual operators.



**Autofocus Camera**

**Color** FZ-SZC100  
FZ-SZC15

**Intelligent Camera**

**Color** FZ-SLC100  
FZ-SLC15

**Innovative zoom function**

With this function, the camera can flexibly respond to inspections on mixed production lines or any changes in its field of vision for additional inspections.

**Intelligent Lighting**

You can control Lighting pattern and brightness levels. Since the most appropriate setting for each task can be chosen from many lighting patterns, stable lighting conditions are always ensured.

\* Function available only with FZ-SLC100 and FZ-SLC15

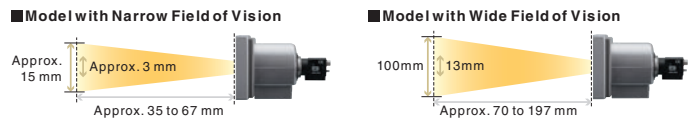
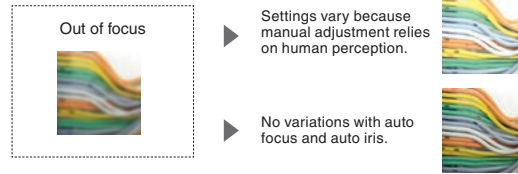

**Lighting Patterns**  
8 places can be controlled

**Brightness Levels**  
256 gradations



**Multi-input Function**

Each camera has its own image buffer for storing image data that is separate from the main memory used for measurement processing. This allows for up to 32 frames of continuous high-speed image capture even while the main memory is processing measurement data.

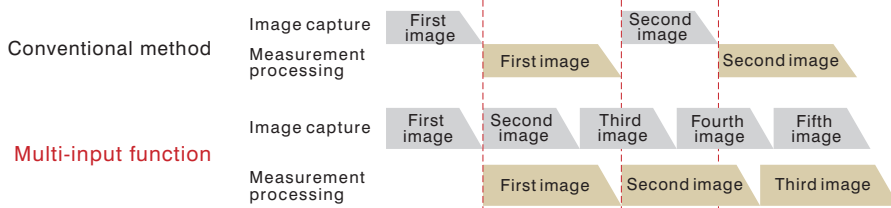

Inspection of characters printed on electronic components

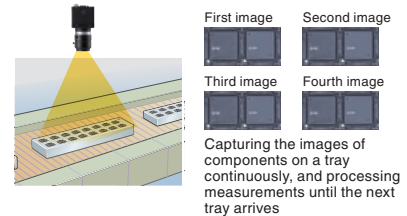

Note: The number of frames that can be captured continuously depends on the controller and the type of camera connected to.

- FZ3-300/H300 Series 300,000-pixel camera: 16 images
- FZ3-700/H700 Series 5-million-pixel camera: 2 images, 2-million-pixel camera: 8 images, 300,000-pixel camera: 32 images

**Camera Cable Extension Unit**

FZ-VSJ

This unit allows to connect camera cables up to 45 meters. The unit is useful when there is a good distance between the control panel and the camera.



\*Up to two Extension Units can be used between the camera and the controller. For more information please refer to Page 25.  
\*Cables can be connected up to 15 meters for 5 million pixel cameras.

**Strobe Controller**

3Z4S-LT MLEK-C100E1TS2

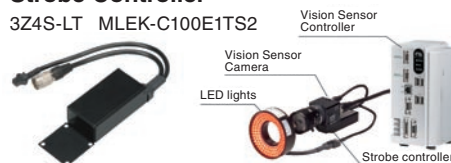

·Lighting conditions can be stored as data.  
·Strobe flash helps lengthen the life of LED lights.

Strobe Controller can be connected to the camera with a single cable. Since it is powered from the controller, no additional power supply for lighting is necessary. The controller sends trigger signals to each light to tell it when to flash. You can set two or more lights at slightly different times to avoid interference between them.

# Preparing for the future ... State-of-the-art processing

FZ3 meets various inspection needs featuring more than 60 processing items that cover not only basic image processing functions but also a number of inspection-related tasks such as data input/output, day-to-day operational management and inclination analysis.

## Filters to optimize input images / Position Correction

### First in the industry Color shadings elimination filter

The filter eliminates Specific background color data that may hamper the detection of defects. It also improves the accuracy of inspection to detect scratches or dirt. This cutting-edge function is made possible only with FZ3's Real Color Sensing technology.



### Color extracting filter

The filter allows the extraction of any specific color from the image. Since you can register up to eight colors, as the colors to be eliminated, you do not need to adjust settings for different processing items. The filter works in two modes, one for extracting the color specified and the other for extracting all colors other than the specified one. You can flexibly switch between the two modes according to requirements for individual inspections.

**First in the industry** All colors other than the ones specified can be extracted. When there are a number of colors you want to extract, this mode saves time in color setting.

You can easily specify any color by just clicking it on the screen. The color chart on the screen, that shows the color you have chosen, enables intuitive operation even for fine adjustments.

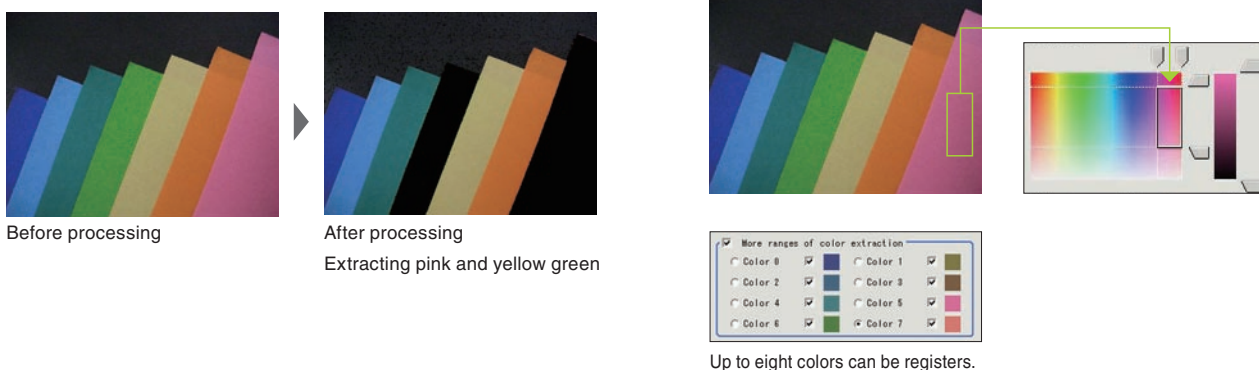

### Elimination of Background

A minimum value and a maximum value are set for each of the RGB colors. Any color depth under the minimum value is specified as "0," and any depth over the maximum value as "255." Then all other depths between them are stretched into a 0 to 255 scale. An area to be inspected is visualized with high contrast while the effects of depths outside this scale are eliminated.

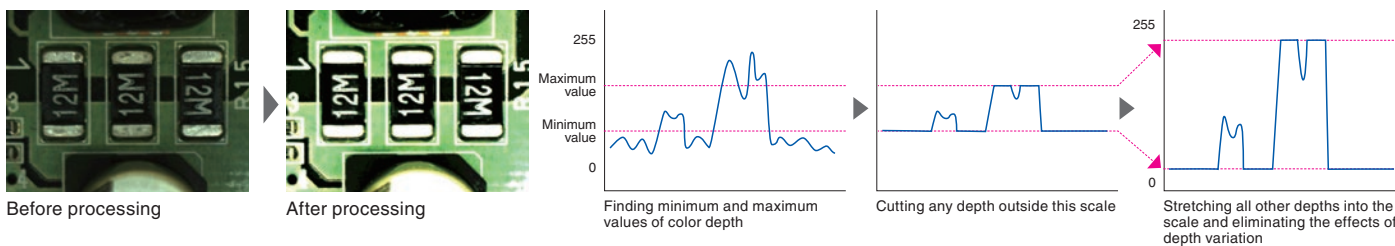

### First in the industry Rectangular Development of Circular Images

This function allows recognition of characters printed along the circumferences of circular surfaces by converting circular images into rectangular forms. The characters can be inspected with the same resolution even after such rectangular development.



# items (approx. 60)

## High Precision Inspections of Defect

### Inspections of Scratches and Dirt

Subtle scratches and dirt can be detected with more fine-tuned conditions compared to conventional inspections. Since you can clearly distinguish defects to be detected from the background, the failure detection rate can be decreased. Combined with our 5 million-pixel camera, this function enables much more precise inspections of scratches.

**Patent Pending** Scratch detection profile displayed on the screen

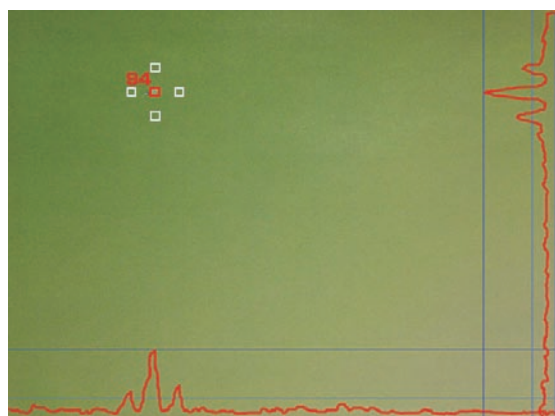

You can confirm wave profiles and comparison elements on the screen. This feature also enables easy thresholding setting and fine adjustments on the screen.

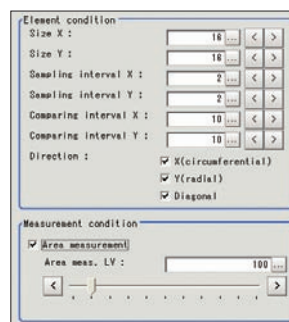

Fine parameters for defect detection allow fine settings at the pixel level.

### Fine Matching / Defect

With our Real Color Sensing technology, FZ3 can accurately recognize and process subtle variations in color. This feature helps you detect unpredictable scratches and dirt. High precision defect inspections are possible by using both Fine Matching and Defect flexibly according to the background of each image.

#### Fine Matching

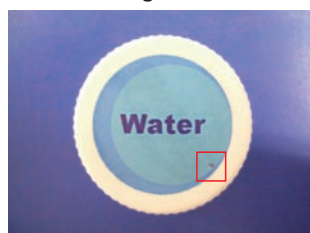

It is useful for detecting scratches, chipped edges or subtle dirt in complex backgrounds.

#### Defect

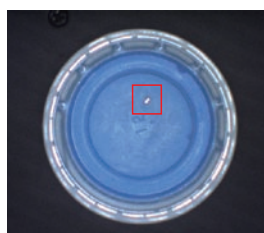

It is useful for detecting scratches and dirt in plain backgrounds.



**Patent Pending**  
**What is Real Color Sensing?**

In order to secure stable measurements in different inspection environments, FZ Series feature Omron's proprietary Real Color Sensing processing, in addition to the conventional color image processing.

#### Color Segmentation Processing

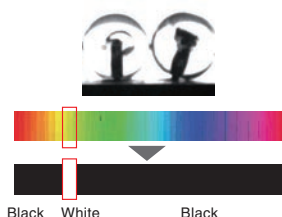

Color images taken by the camera are processed after being converted into black and white pixels. The color extracted is represented as white, and the other colors as black. Based on minimum information, high speed processing is possible. Since color data is limited only to brightness, however, it takes a long time to make optical adjustments for extracting color features.

#### Color Image Processing

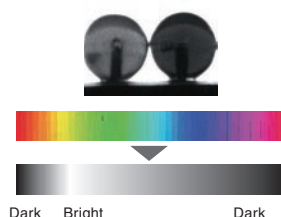

Color images are converted into 256 levels of black-and-white brightness and the contrasts of specific colors is enhanced. More precise, stable results can be produced compared to color segmentation. However, this method has difficulty in capturing subtle variations in color because all colors are converted into black-and-white brightness levels. Therefore, it is difficult to detect subtle changes in images with low contrast.

#### Real Color Sensing

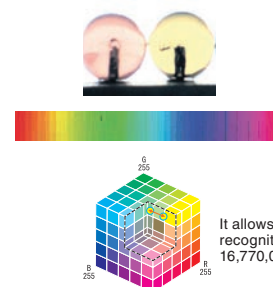

Different colors are represented as different positions in the 3D RGB space. Subtle variations in color can be recognized by representing them as distances between different color pixels comprising this space. Thus, scratches and dirt can be detected accurately even in images with low contrast.

# Preparing for the future ... State-of-the-art processing

## High Speed / High Precision Pattern Recognition

### Shape Search / EC Circle Search

Omron's proprietary Edge Code (EC) algorithm allows faster, more stable searches. Unlike the conventional search algorithms, EC algorithm searches the shapes of workpieces by extracting brightness changes as edges. This result in stable searches without being affected by deformation or dirt.

#### Shape Search

It is useful for promptly finding specific shapes in images with low contrast.

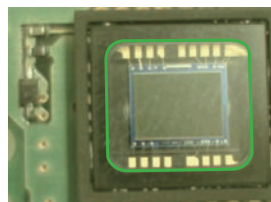

#### EC Circle Search

Circler forms can be recognized geometrically based on edge data.

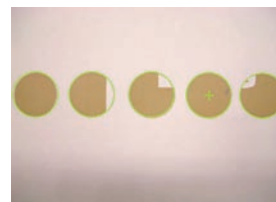

New

### Sensitive Search

This allows the recognition of very subtle differences that cannot be detected through ordinary search processes, by dividing the registered model image into several pieces and carefully matching them. Thus you don't have to spend a lot of time for delicate threshold setting.

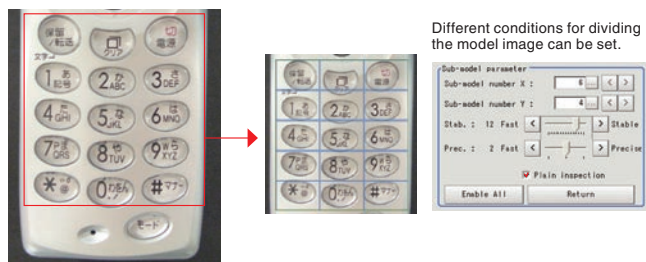

### Flexible Search

When inspecting workpieces with some variations in shape, such variations are sometimes recognized erroneously as defects. Flexible Search ensures accurate searches regardless of some variations in print quality or shape, by registering several images of non-defective products as models. It helps you decrease your inspection failure rate by rejecting defective products only.

#### ■ Inspection of characters on IC chips



Avoiding inspection failures

## Area / Labeling

### First in its class Dynamic segmentation and high-performance labeling

This item features a dynamic segmentation in addition to the conventional labeling. This function ensures the accurate detection of labels by automatically sensing any uneven color depth in the same image and changing thresholds locally.

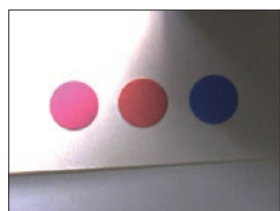

Ordinary segmentation



Dynamic segmentation

#### Easy to sort, Wide variety of conditions to be extracted

- Area
- Gravity (x, y)
- Main axial angle
- Major axis, minor axis and ratio of an ellipse
- Width, height and coordinate (x, y) of a circumscribed rectangle
- Perimeter
- Circularity
- Major axis and minor axis of a rotating rectangle
- Radius of an inscribed circle
- Radius of a circumscribed circle
- Number of holes

## High Performance Edge Detection

### Scan Edge Position, Scan Edge Width

Edge positions and widths can be accurately detected by dividing the area to be inspected into several segments. Scan Edge Position measures the points closest and farthest to the edge as well as the inclination and surface conditions of the workpiece to be inspected. Scan Edge Width measures the local and average widths of the workpiece. This allows the accurate measurement of the positions of the workpiece's peripheral parts as well as its bore diameters. Edge detection method can be chosen from the intensity projection method and the differentiation method.

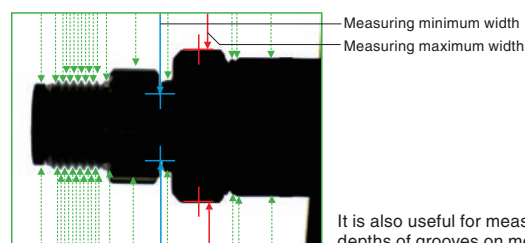

It is also useful for measuring the depths of grooves on metal shafts.

# items (approx. 60)

## Character / Code Recognition

### First in its class Read Bar Codes / 2D Codes

It allows the detection of the types of products before inspections as well as the collection and accumulation of information on inspections.

#### Switching among different inspection items according to the types of products

Different sets of inspection items can be automatically set for different types of products detected through code reading processes. The item, that covers all processes from product type detection to inspections without involving the host, can save time for interconnection and programming.

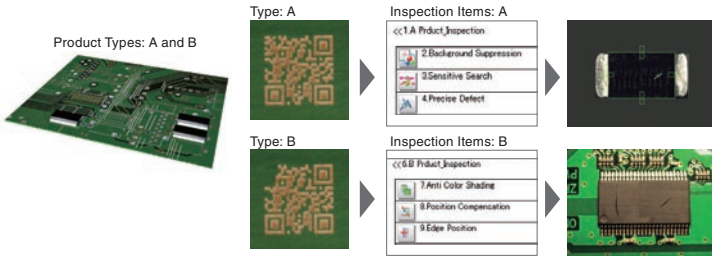

#### Collecting and accumulating information on inspections in real time

You can collect the serial numbers of components and measuring results in real time while they are being inspected. The causes of defects can be tracked down immediately by consolidating such serial numbers and measuring results at the host.

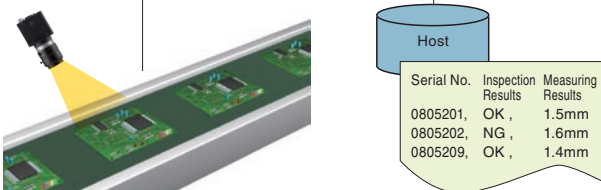

#### Reading different codes at a time

Two or more different codes in the same field of vision can be read by utilizing a high resolution camera. This function contributes to the reduction of inspection tact time.

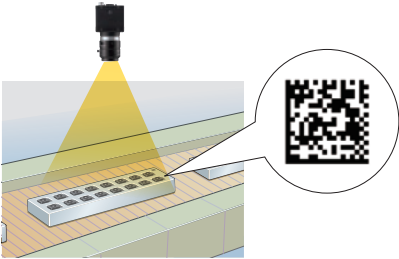

#### Codes that can be read with FZ3

##### Bar codes



##### 2D codes



## Character Inspection / Date Verification



This item allows easy inspections of characters by registering specific characters in the model dictionary and specifying areas to be inspected.

- OCR mode: Reading printed characters and outputting them to an external device.
- OCV mode: Judging matching with registered models
- OCR + Count: Characters counted simultaneously

#### Calendar function

Character strings to be inspected are automatically updated by specifying duration of use. It can allow the inspections of encrypted dates (such as "X" representing 10).

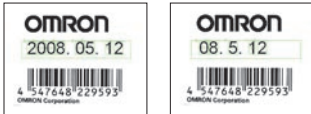

Compatible with various date formats

## Items supporting measurement

### First in the industry High Precision Calibration

This is a function corresponding to trapezoidal distortion correction. High precision measurements are possible even when cameras are installed at an angle.

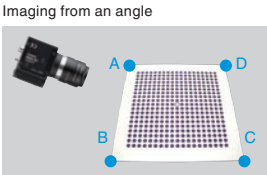

#### Conventional calibration

When trapezoidal distortions are caused by perspective differences, significant calibration errors are observed.

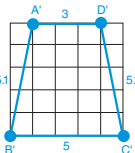

#### FZ3

High precision calibrations are possible for trapezoidal distortions by using parameters considering perspective transformation.

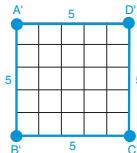

### Coping with geometric computation Circle/Line Regression

With this item, you can cope with geometric computation in addition to functional computation. It allows you to relate coordinates very easily while looking at images.



You can obtain the center or radius of a circle from an arbitrary number of points on its perimeter.



You can obtain a straight line, the intersection of two straight lines and its angle, or the distance between a straight line and a point from an arbitrarily selected number of points.

### Compatible with PLC link Serial Data Communication



This compatibility with PLC link allows the considerable reduction of man-hours for designing a communication program used between FZ3 and PLC link. Compatible with: Omron CS / CJ / CP / NS Series

# Pursuit of Usability

## Designing

### New Stress-Free Menu

Our flow menu has made considerable progress focusing on user-friendly setting at the introduction stage.

**Flow Group function**  
Processing items can be named and grouped. You can efficiently manage a long work flow by assigning a folder to each processing item.

A long flow can be streamlined.

**Performing different processing items at a time**  
You can copy or delete two or more processing items at a time by just checking them on the screen.

**Copy & paste processing items from another scene.**  
You can set up a new flow menu by combining different processing items copied from other scenes. When you want to utilize the setting of other scene, you do not need to make adjustments.

### Conditional Branching / DI Branching

Flow menus can be changed later by branching and looping according to measurement results. Flow menu designing at the programming level is possible through a simple process of specifying a processing item for Input Condition Branching.

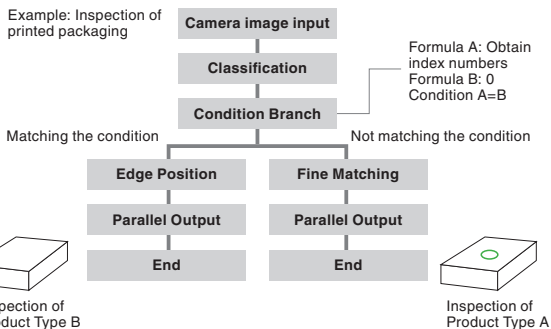

## Setting and Adjustment On Your PC Without Stopping the operation

### Simulating measurement

You can simulate FZ3's measurement procedures on your PC. You can make test measurements of images stored with the logging function on your PC and make adjustments without stopping the line. This saves a lot of time at the production line. Images taken by digital cameras can also be used. Contact your OMRON representative for details.

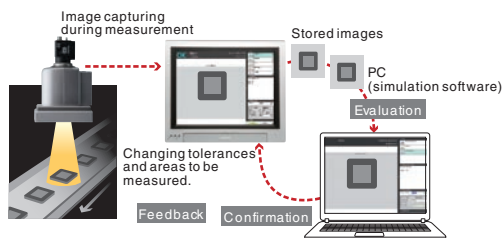

### Continuous test measurements using stored images

You can copy images stored in the controller and make continuous test measurements using it on your PC. Continuous measurements of hundreds of images can be performed by a simple click. Furthermore, new Judgment Monitoring function is added to stop measurement procedures only when NG occurs. This helps you to cope with problems according to their cause thus enables efficient inspections.

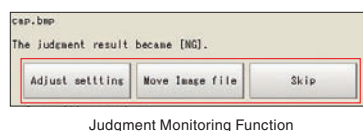



# Operation

## Customizing displays to meet work site needs

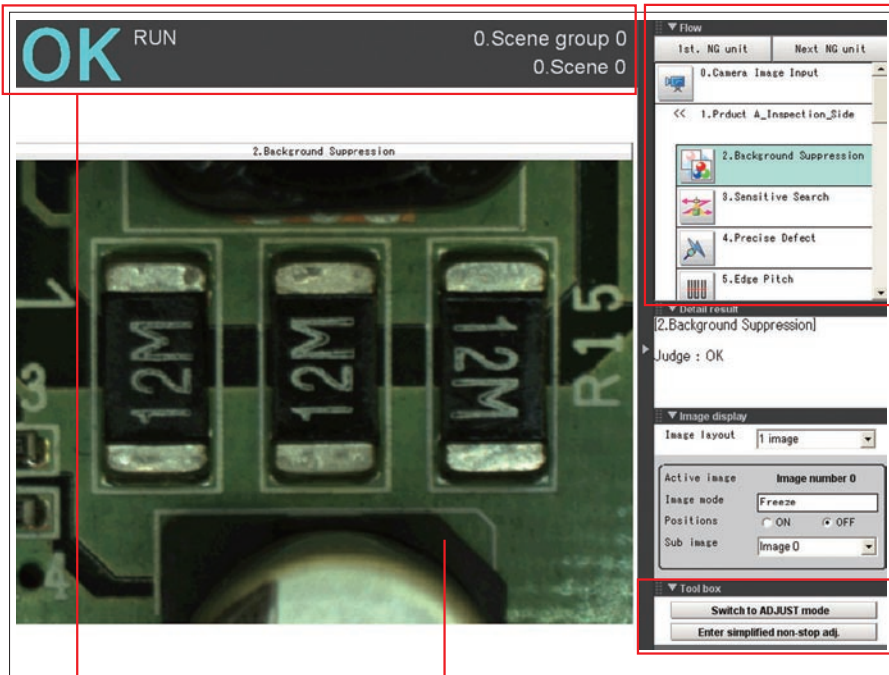

### "No Display" setting during operation

You can set "No Display" of any processing items during operation.

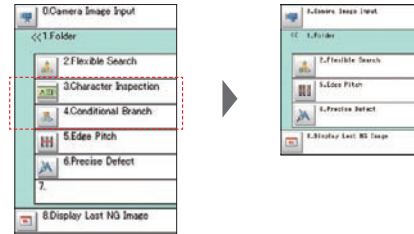

### Shortcut buttons

You can arrange a set of shortcut buttons as you like. With these buttons, you can promptly cope with any problems or adjustments whenever necessary during operation.



Example of customization

### Customization of Displays

The flexible customization of the RUN mode view is possible. Not only items to be displayed but also their layout and sizes of characters used can also be changed. This enables the creation of the most easy-to-use displays for the on-site operators.

Example of customization



### Multi-screen Display, Display of the latest NG image

Displays on the Measurement screen can be changed as you like according to the number of cameras and their purposes. You can display a detail of a workpiece and its overall image at the same time on the screen. This function also enables a comparison between an NG image and the image actually being inspected.

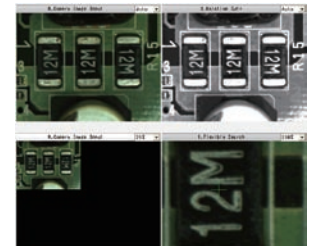

# Adjustment / Analysis

## Trend Monitor for Analyzing Measurement Results

The system not only displays measured values in graph form, it also can display warnings before defects occur. Use the warning range settings for measured values to help prevent NG occurrences in advance. This allows for feedback to previous work processes, and can be useful in casual analyzing after defects occur.

### Prevent High Defect Rates in Advance

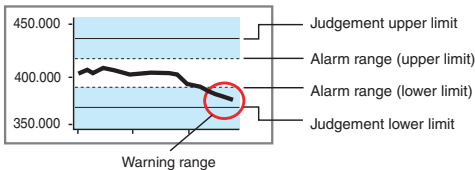

### Cause Analysis when Defects Occur

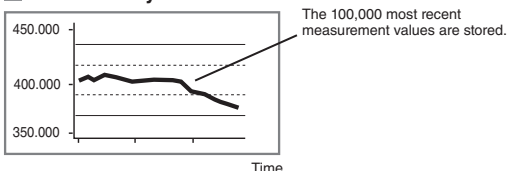

## Storing images for each condition

Images of defects can be stored in different folders according to their causes. These images can later be analyzed efficiently.

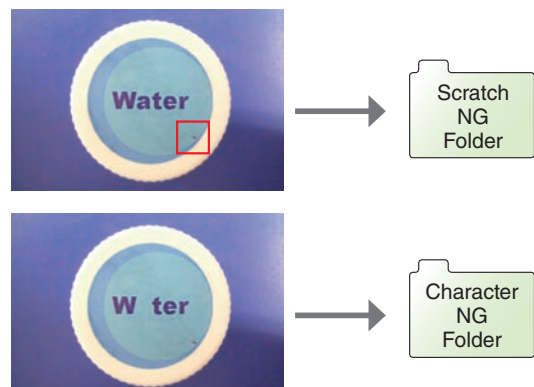

# Basic Configuration

## Controllers

Our lineup includes top-of-the-line models designed for high-speed processing of items requiring outstanding problem-solving capability as well as models with standard functions.

## Optimum performance for each application



Controller integrated with LCD



Box-type Controller



Cutting-edge Image Processing  
High Grade Processing Items

FZ3 features a set of "High Grade" processing items that solves inspection/measurement challenges requiring difficult setting and many man-hours. You can find solutions to seemingly impossible problems by combining our hardware units (such as the 5 million-pixel camera, small camera and high-speed CPU) and 60 processing items in various ways.



Panorama+



Camera Image input HDR+



Trapezoidal Correction+

- Halation cut+
- Stripe Removal Filter+
- Shape search+
- Labeling+
- Calibration+
- 2DC+
- Barcode+

## Cameras and Accessories

### Digital cameras

### Small digital cameras

#### 5 million-pixel



#### 2 million-pixel



#### 300,000-pixel



#### 300,000-pixel flat type



#### 300,000-pixel pen type



### Lenses

### Camera Cables



High-resolution, low-distortion lenses  
FZ-LEH Series



CCTV lens  
3Z4S-LE Series



Small lens  
FZ-LES Series



Camera Cables  
FZ-VS



Bend resistant camera cables  
FZ-VSB



Right-angle camera cable  
FZ-VSL



Long-distance camera cable  
FZ-VS2



Long-distance right-angle camera cable  
FZ-VSL2

## Top-of-the-line High Grade, High Speed Controllers

With the industry's fastest CPU, the controllers promptly process cutting-edge, high grade processing items. Not only a 2 million-pixel camera but also a 5 million-pixel-camera can also be connected to the controllers.



Controller integrated with LCD	Two-camera controllers	FZ3-H700 (NPN) / FZ3-H705 (PNP)
	Four-camera controllers	FZ3-H700-10 (NPN) / FZ3-H705-10 (PNP)
Box-type Controller	Two-camera controllers	FZ3-H750 (NPN) / FZ3-H755 (PNP)
	Four-camera controllers	FZ3-H750-10 (NPN) / FZ3-H755-10 (PNP)

## Fastest in the industry High speed controllers

High-resolution 5 million-pixel-cameras can be connected to the controllers with the industry's fastest CPU. They are ideal for high speed processing of standard inspection items.



Controller integrated with LCD	Two-camera controllers	FZ3-700 (NPN) / FZ3-705 (PNP)
	Four-camera controllers	FZ3-700-10 (NPN) / FZ3-705-10 (PNP)
Box-type Controller	Two-camera controllers	FZ3-750 (NPN) / FZ3-755 (PNP)
	Four-camera controllers	FZ3-750-10 (NPN) / FZ3-755-10 (PNP)

## High problem solving capability High grade controllers

These standard controllers feature our cutting-edge High Grade algorithm. They allow flexible problem solving capability and high speed processing at the same time.



Controller integrated with LCD	Two-camera controllers	FZ3-H300 (NPN) / FZ3-H305 (PNP)
	Four-camera controllers	FZ3-H300-10 (NPN) / FZ3-H305-10 (PNP)
Box-type Controller	Two-camera controllers	FZ3-H350 (NPN) / FZ3-H355 (PNP)
	Four-camera controllers	FZ3-H350-10 (NPN) / FZ3-H355-10 (PNP)

## Featuring all important basic functions Standard controllers

They cover all standard functions and processing items. Their performance is more than adequate.



Controller integrated with LCD	Two-camera controllers	FZ3-300 (NPN) / FZ3-305 (PNP)
	Four-camera controllers	FZ3-300-10 (NPN) / FZ3-305-10 (PNP)
Box-type Controller	Two-camera controllers	FZ3-350 (NPN) / FZ3-355 (PNP)
	Four-camera controllers	FZ3-350-10 (NPN) / FZ3-355-10 (PNP)

### Intelligent camera



Narrow field of vision  
FZ-SLC15



Wide field of vision  
FZ-SLC100

### Autofocus camera



Narrow field of vision  
FZ-SZC15



Wide field of vision  
FZ-SZC100

### Cable extension unit



Cable extension unit  
FZ-VSJ

### Strobe controller



Strobe controller designed specifically for FZ Series  
3Z4S-LT MLEK-C100E1TS2  
Manufactured by MORITEX Corporation

### Intelligent camera diffusion plate



Narrow field of vision  
FZ-SLC15-DL  
Wide field of vision  
FZ-SLC100-DL

## Peripheral devices



LCD monitor  
FZ-M08



Monitor cable  
FZ-VM



Parallel cable  
FZ-VP



USB memory  
FZ-MEM1G



VESA attachment  
FZ-VESA



Desktop controller stand  
FZ-DS

# Ordering Information

## FZ3 Series

Item	Descriptions			Model	Remarks	
Controllers	High grade, high speed controllers	Controller integrated with LCD	Two-camera controllers	NPN	FZ3-H700	With touch pen
				PNP	FZ3-H705	
			Four-camera controllers	NPN	FZ3-H700-10	
				PNP	FZ3-H705-10	
		Box-type Controller	Two-camera controllers	NPN	FZ3-H750	-
				PNP	FZ3-H755	
	Four-camera controllers		NPN	FZ3-H750-10		
			PNP	FZ3-H755-10		
	High grade controllers	Controller integrated with LCD	Two-camera controllers	NPN	FZ3-H300	With touch pen
				PNP	FZ3-H305	
			Four-camera controllers	NPN	FZ3-H300-10	
				PNP	FZ3-H305-10	
Box-type Controller		Two-camera controllers	NPN	FZ3-H350	-	
			PNP	FZ3-H355		
	Four-camera controllers	NPN	FZ3-H350-10			
		PNP	FZ3-H355-10			
High speed controllers	Controller integrated with LCD	Two-camera controllers	NPN	FZ3-700	With touch pen	
			PNP	FZ3-705		
		Four-camera controllers	NPN	FZ3-700-10		
			PNP	FZ3-705-10		
	Box-type Controller	Two-camera controllers	NPN	FZ3-750	-	
			PNP	FZ3-755		
Four-camera controllers		NPN	FZ3-750-10			
		PNP	FZ3-755-10			
Standard controllers	Controller integrated with LCD	Two-camera controllers	NPN	FZ3-300	With touch pen	
			PNP	FZ3-305		
		Four-camera controllers	NPN	FZ3-300-10		
			PNP	FZ3-305-10		
	Box-type Controller	Two-camera controllers	NPN	FZ3-350	-	
			PNP	FZ3-355		
Four-camera controllers		NPN	FZ3-350-10			
		PNP	FZ3-355-10			
Cameras	Intelligent cameras	Wide field of vision	Color	FZ-SLC100	Camera + Zoom, Autofocus Lens + Intelligent Lighting	
		Narrow field of vision	Color	FZ-SLC15		
	Autofocus cameras	Wide field of vision	Color	FZ-SZC100	Camera + Zoom, Autofocus Lens	
		Narrow field of vision	Color	FZ-SZC15		
	Digital cameras	300,000 Pixels	Monochrome	FZ-S	Lens required	
			Color	FZ-SC		
		2 million pixels	Monochrome	FZ-S2M		
			Color	FZ-SC2M		
		5 million pixels	Monochrome	FZ-S5M		
			Color	FZ-SC5M		
Small digital cameras	300,000-pixel flat type	Monochrome	FZ-SF	CCTV lens required		
		Color	FZ-SFC			
	300,000-pixel pen type	Monochrome	FZ-SP			
		Color	FZ-SPC			
Cameras peripheral devices	Intelligent camera diffusion plate	Wide field of vision	FZ-SLC100-DL	-		
		Narrow field of vision	FZ-SLC15-DL	-		
	CCTV Lenses			3Z4S-LE Series	-	
	Extension Tubes					
	Low-distortion Lenses			FZ-LEH5/LEH8/LEH12/LEH16/LEH25/LEH35/LEH50/LEH75/LEH100	Low distortion lens for 2-million pixel cameras and 5 million-pixel cameras	
	Lenses for small camera			FZ-LES3/LES6/LES16/LES30	Lens for 300,000-pixel small cameras	
	Extension Tubes for small camera			FZ-LESR	Extension Tubes for 300,000-pixel small cameras	

Item	Descriptions		Model	Remarks
Cables	Camera Cable		FZ-VS	Cable length: 2 m, 5 m, or 10 m (See note 2.)
	Bend resistant Camera Cables		FZ-VSB	Cable length: 2 m, 5 m, or 10 m (See note 3.)
	Right-angle Camera Cable (See note 1.)		FZ-VSL	Cable length: 2 m, 5 m, or 10 m (See note 2.)
	Long-distance camera cable		FZ-VS2	Cable length: 15 m (See note 4.)
	Long-distance right-angle camera cable		FZ-VSL2	Cable length: 15 m (See note 4.)
	Cable extension unit		FZ-VSJ	Up to two Extension Units and three Cables can be connected.(Maximum cable length: 45 m (See note 5.))
	Monitor cable		FZ-VM	Cable length: 2 m or 5 m
Peripheral devices	Parallel cable		FZ-VP	Cable length: 2 m or 5 m
	LCD monitor		FZ-M08	For Box-type Controllers
	USB memory	1GB	FZ-MEM1G	Capacity: 1 GB
	VESA attachment		FZ-VESA	For installing the LCD integrated-type controller
	Desktop controller stand		FZ-DS	For installing the LCD integrated-type controller
Mouse			—	Recommended Products (Optical Mouse) • Microsoft Corporation: Compact Optical Mouse, U81 Series
External Lighting			3Z4S-LT Series	—
Strobe Controller (for FZ Series Vision Sensors)			Manufactured by MORITEX Corporation 3Z4S-LT MLEK-C100E1TS2	Required to control external lighting from a Controller
Adapter for the strobe controller designed specifically for the 5 million -pixel camera			Manufactured by MORITEX Corporation 3Z4S-LT LBK-003	Required to mount a strobe controller on a 5 million-pixel camera

Note 1: This Cable has an L-shaped connector on the Camera end.

2: The 10-m cable cannot be used for the intelligent camera, autofocus camera and 5 million-pixel camera.

3: The 10-m cable cannot be used for the intelligent camera, autofocus camera 2 million-pixel camera and 5 million-pixel camera.

4: The 15-m cable cannot be used for the intelligent camera, autofocus camera and 5 million-pixel camera.

5: The maximum cable length depends on the Camera being connected, and the model and length of the Cable being used. For further information, please refer to the "Cameras / Cables" table in Page 21.

### Camera Connection Table

Type of camera	Model	Resolution	Standard controllers (FZ3-3□□, FZ3-3□□-10)	High grade controllers (FZ3-H3□□, FZ3-H3□□-10)	High speed controllers (FZ3-7□□, FZ3-7□□-10)	High grade, high speed controllers (FZ3-H7□□, FZ3-H7□□-10)
Intelligent cameras	FZ-SLC100	300,000 Pixels	○	○	○	○
	FZ-SLC15	300,000 Pixels	○	○	○	○
Autofocus cameras	FZ-SZC100	300,000 Pixels	○	○	○	○
	FZ-SZC15	300,000 Pixels	○	○	○	○
Digital cameras	FZ-SC	300,000 Pixels	○	○	○	○
	FZ-S	300,000 Pixels	○	○	○	○
	FZ-SC2M	2 million pixels	×	×	○	○
	FZ-S2M	2 million pixels	×	×	○	○
	FZ-SC5M	5 million pixels	×	×	○ (See note1.)	○ (See note1.)
	FZ-S5M	5 million pixels	×	×	○ (See note1.)	○ (See note1.)
Small digital cameras	FZ-SFC	300,000 Pixels	○	○	○	○
	FZ-SF	300,000 Pixels	○	○	○	○
	FZ-SPC	300,000 Pixels	○	○	○	○
	FZ-SP	300,000 Pixels	○	○	○	○

Note 1: When connecting 5 million-pixel cameras, up to two cameras can be connected.

### Cameras / Cables Connection Table

Type of camera	Model	Cable length	Intelligent cameras Autofocus cameras	Digital cameras			Small digital cameras
				300,000-pixel	2 million-pixel	5 million-pixel	Pen type / flat type
Camera Cables Right-angle camera cables	FZ-VS FZ-VSL	2m	○	○	○	○	○
		5m	○	○	○	○	○
		10m	×	○	○	×	○
Bend resistant camera cables	FZ-VSB	2m	○	○	○	○	○
		5m	○	○	○	○	○
		10m	×	○	×	×	○
Long-distance camera cable Long-distance right-angle camera cable	FZ-VS2 FZ-VSL2	15m	×	○	○	×	○

# Ratings and Specifications (Controllers)

High grade, high speed controller, High speed controller

Model		NPN Output	FZ3-700	FZ3-700-10	FZ3-H700	FZ3-H700-10	FZ3-750	FZ3-750-10	FZ3-H750	FZ3-H750-10	
		PNP Output	FZ3-705	FZ3-705-10	FZ3-H705	FZ3-H705-10	FZ3-755	FZ3-755-10	FZ3-H755	FZ3-H755-10	
Connected Camera		Please refer to the "Camera Connection" table in Page 21.									
No. of Cameras(See note 1.)		2	4	2	4	2	4	2	4		
Processing resolution	When connected to a 300,000-pixel camera	640(H)×480(V)									
	When connected to a 2 million-pixel camera	1600(H)×1200(V)									
	When connected to a 5 million-pixel camera	2448(H)×2044(V)									
No. of scenes		32									
Number of logged images (See note 2.)	When connected to a 300,000-pixel camera	Connected to 1 camera	Color camera: 250, Monochrome Camera: 252								
		Connected to 2 cameras	Color camera: 125, Monochrome Camera: 126								
		Connected to 3 cameras	Color camera: 83, Monochrome Camera: 84								
		Connected to 4 cameras	Color camera: 62, Monochrome Camera: 63								
	When connected to a 2 million-pixel camera	Connected to 1 camera	Color camera: 40, Monochrome Camera: 40								
		Connected to 2 cameras	Color camera: 20, Monochrome Camera: 20								
		Connected to 3 cameras	Color camera: 13, Monochrome Camera: 13								
		Connected to 4 cameras	Color camera: 10, Monochrome Camera: 10								
	When connected to a 5 million-pixel camera	Connected to 1 camera	Color camera: 11, Monochrome Camera: 11								
		Connected to 2 cameras	Color camera: 5, Monochrome Camera: 5								
Codes that can be read with FZ3		< Bar Codes > JAN/EAN/UPC (including add-on codes), Code 39, Codabar (NW-7), ITF (Interleaved 2 of 5), Code 93, Code 128, GS1-128, GS1 DataBar (RSS-14 / RSS Limited / RSS Expanded) < 2D Codes > Data Matrix (ECC200), QR Code									
Operation		Touch pen, mouse, etc.					Mouse or similar device				
Settings		Create series of processing steps by editing the flowchart (Help messages provided).									
Serial communications		RS-232C/422A:1CH									
Network communications		Ethernet 100BASE-TX/10BASE-T									
Parallel I/O		11 inputs (RESET, STEP, DSA, and DI 0 to 7), 26 outputs (RUN, BUSY, GATE, OR, READY, ERROR, STGOUT 0 to 3, and DO 0 to 15)									
Monitor interface		Integrated Controller and LCD 12.1 inch TFT color LCD (Resolution: XGA 1,024 × 768 dots)					Analog RGB video output, 1 channel (Resolution: XGA 1,024 × 768 dots)				
USB interface		4 channels (supports USB 1.1 and 2.0)									
Power supply voltage		20.4 to 26.4 VDC									
Current consumption (See note 4.)	When connected to a intelligent or autofocus camera	5 A max.	7.5 A max.	5 A max.	7.5 A max.	5 A max.	7.5 A max.	5 A max.	7.5 A max.		
	When connected to a 300,000-pixel camera	3.7 A max.	4.9 A max.	3.7 A max.	4.9 A max.	3.7 A max.	4.9 A max.	3.7 A max.	4.9 A max.		
	When connected to a 2 million-pixel camera										
	When connected to a 5 million-pixel camera										
Ambient temperature range		Operating: 0 to 45°C, 0 to 50°C (See note 3.), Storage: -20 to 65°C (with no icing or condensation)									
Ambient humidity range		Operating and storage: 35% to 85% (with no condensation)									
Weight		Approx. 3.2 kg	Approx. 3.4 kg	Approx. 3.2 kg	Approx. 3.4 kg	Approx. 1.8 kg	Approx. 1.9 kg	Approx. 1.8 kg	Approx. 1.9 kg		
Accessories		Touch pen (one, inside the front panel), Please Read First, Instruction Manual (Setup), 6 mounting brackets					Please Read First, Instruction Manual (Setup)				

Note 1: When connecting 5 million-pixel cameras, up to two cameras can be connected.

2: The number of logged images will vary when connecting multiple Cameras with different models.

3: The operating mode can be switched from the Controller Menu settings.

4: When the strobe controller is connected to the lights, the controller uses power as much as it does when connected to the intelligent camera.

5: Do not install the firmware for FZ2 in any High Grade High Speed or High Grade controller of the FZ3 series. It will lead to the failure of the controller. For software download, please contact your Omron representative.

## System configuration

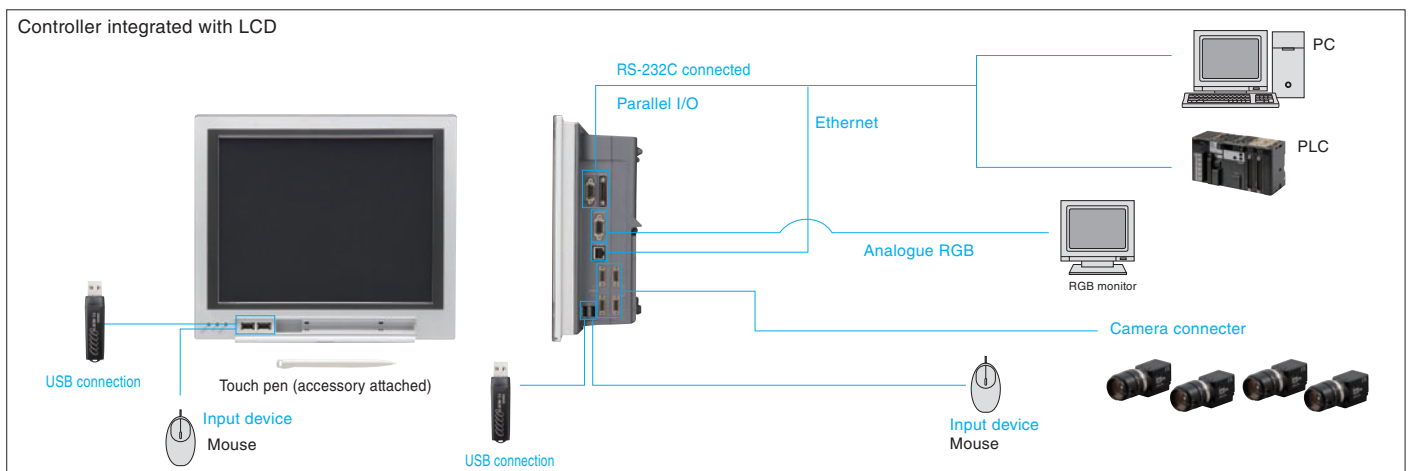

## High grade controllers, Standard controllers

Model		NPN Output	FZ3-300	FZ3-300-10	FZ3-H300	FZ3-H300-10	FZ3-350	FZ3-350-10	FZ3-H350	FZ3-H350-10
		PNP Output	FZ3-305	FZ3-305-10	FZ3-H305	FZ3-H305-10	FZ3-355	FZ3-355-10	FZ3-H355	FZ3-H355-10
Connected Camera		Please refer to the "Camera Connection" table in Page 21.								
No. of Cameras		2	4	2	4	2	4	2	4	
Processing resolution		640(H)×480(V)								
No. of scenes		32								
Number of logged images (See note 1.)	When connected to a 300,000-pixel camera	Connected to 1 camera	Color camera: 250, Monochrome Camera: 252							
		Connected to 2 cameras	Color camera: 125, Monochrome Camera: 126							
		Connected to 3 cameras	Color camera: 83, Monochrome Camera: 84							
		Connected to 4 cameras	Color camera: 62, Monochrome Camera: 63							
Operation		Touch pen, mouse, etc.				Mouse or similar device				
Settings		Create series of processing steps by editing the flowchart (Help messages provided).								
Serial communications		RS-232C/422A:1CH								
Network communications		Ethernet 100BASE-TX/10BASE-T								
Parallel I/O		11 inputs (RESET, STEP, DSA, and DI 0 to 7), 26 outputs (RUN, BUSY, GATE, OR, READY, ERROR, STGOUT 0 to 3, and DO 0 to 15)								
Monitor interface		Integrated Controller and LCD 12.1 inch TFT color LCD (Resolution: XGA 1,024 × 768 dots)				Analog RGB video output, 1 channel (Resolution: XGA 1,024 × 768 dots)				
USB interface		4 channels (supports USB 1.1 and 2.0)								
Power supply voltage		20.4 to 26.4 VDC								
Current consumption (See note 3.)	When connected to an intelligent or autofocus camera	5 A max.	7.5 A max.	5 A max.	7.5 A max.	5 A max.	7.5 A max.	5 A max.	7.5 A max.	
	When connected to a 300,000-pixel camera	3.7 A max.	4.9 A max.	3.7 A max.	4.9 A max.	3.7 A max.	4.9 A max.	3.7 A max.	4.9 A max.	
Ambient temperature range		Operating: 0 to 45°C, 0 to 50°C (See note 2.), Storage: -20 to 65°C (with no icing or condensation)								
Ambient humidity range		Operating and storage: 35% to 85% (with no condensation)								
Weight		Approx. 3.2 kg	Approx. 3.4 kg	Approx. 3.2 kg	Approx. 3.4 kg	Approx. 1.8 kg	Approx. 1.9 kg	Approx. 1.8 kg	Approx. 1.9 kg	
Accessories		Touch pen (one, inside the front panel), Please Read First, Instruction Manual (Setup), 6 mounting brackets				Please Read First, Instruction Manual (Setup)				

Note 1: The number of logged images will vary when connecting multiple Cameras with different models.

2: The operating mode can be switched from the Controller Menu settings.

3: When the strobe controller is connected to the lights, the controller uses power as much as it does when connected to the intelligent camera.

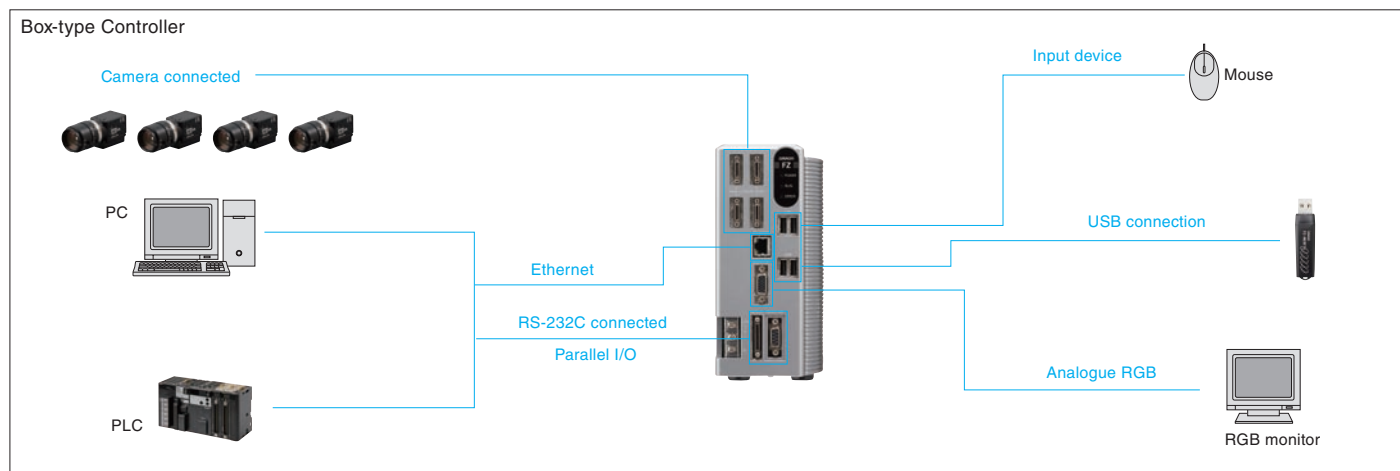

# Ratings and Specifications (Cameras)

## Intelligent camera, autofocus camera

	FZ-SLC100	FZ-SLC15	FZ-SZC100	FZ-SZC15
Image elements	Interline transfer reading all pixels, 1/3-inch CCD image elements			
Color/Monochrome	Color			
Effective pixels	640(H)×480(V)			
Pixel size	7.4(μm)×7.4(μm)			
Shutter function	Electronic shutter; select shutter speeds from 1/10 to 1/50,000 s			
Partial function	12 to 480 lines			
Frame rate (image read time)	80fps(12.5ms)			
Field of vision (See note 2.)	13 to 100mm (See note1.)	2.9 to 14.9mm (See note1.)	13 to 100mm (See note1.)	2.9 to 14.9mm (See note1.)
Installation distance	70 to 190mm (See note1.)	35 to 55mm (See note1.)	77.5 to 197.5mm (See note1.)	47.5 to 67.5mm
LED class (See note 3.) (lighting)	Class 2		-	
Ambient temperature range	Operating: 0 to 50°C Storage: -25 to 65°C (with no icing or condensation)			
Ambient humidity range	Operating and storage: 35% to 85% (with no condensation)			
Weight	Approx. 670 g	Approx. 700 g	Approx. 500 g	
Accessories	Instruction Sheet and hexagonal wrench			

Note 1: Tolerance: ±5% max.

2: The length of the visual field is the lengths along the Y axis.

3: Applicable standards: IEC 60825-1: 1993 + A1: 1997 + A2-2001, EN 60825-1: 1994 + A1: 2002 + A2: 2001

## Digital cameras

	FZ-S	FZ-SC	FZ-S2M	FZ-SC2M	FZ-S5M	FZ-SC5M
Image elements	Interline transfer reading all pixels, 1/3-inch CCD image elements		Interline transfer reading all pixels, 1/1.8-inch CCD image elements		Interline transfer reading all pixels, 2/3-inch CCD image elements	
Color/Monochrome	Monochrome	Color	Monochrome	Color	Monochrome	Color
Effective pixels	640(H)×480(V)		1600(H)×1200(V)		2448(H)×2044(V)	
Pixel size	7.4(μm)×7.4(μm)		4.4(μm)×4.4(μm)		3.45(μm)×3.45(μm)	
Shutter function	Electronic shutter; select shutter speeds from 1/10 to 1/50,000 s		Electronic shutter; select shutter speeds from 1/10 to 1/50,000 s		Electronic shutter; select shutter speeds from 1/10 to 1/50,000 s	
Partial function	12 to 480 lines		12 to 1200 lines		12 to 2044 lines	
Frame rate (image read time)	80fps(12.5ms)		30fps(33.3ms)		16fps(62.5ms)	
Field of vision, installation distance	Selecting a lens according to the field of vision and installation distance					
Ambient temperature range	Operating: 0 to 50°C Storage: -25 to 65°C (with no icing or condensation)		Operating: 0 to 40°C Storage: -25 to 65°C (with no icing or condensation)		Operating: 0 to 40°C Storage: -25 to 65°C (with no icing or condensation)	
Ambient humidity range	Operating and storage: 35% to 85% (with no condensation)					
Weight	Approx.55g		Approx. 76g		Approx.140g	
Accessories	Instruction manual					

## Small digital cameras

	FZ-SF	FZ-SFC	FZ-SP	FZ-SPC
Image elements	Interline transfer reading all pixels, 1/3-inch CCD image elements			
Color/Monochrome	Monochrome	Color	Monochrome	Color
Effective pixels	640(H)×480(V)			
Pixel size	7.4(μm)×7.4(μm)			
Shutter function	Electronic shutter; select shutter speeds from 1/10 to 1/50,000 s			
Partial function	12 to 480 lines			
Frame rate (image read time)	80fps(12.5ms)			
Field of vision, installation distance	Selecting a lens according to the field of vision and installation distance			
Ambient temperature range	Operating: 0 to 50°C (camera amp) 0 to 45°C (camera head) Storage: -25 to 65°C (with no icing or condensation)		Operating: 0 to 50°C (camera amp) 0 to 45°C (camera head) Storage: -25 to 65°C (with no icing or condensation)	
Ambient humidity range	Operating and storage: 35% to 85% (with no condensation)		Operating and storage: 35% to 85% (with no condensation)	
Weight	Approx.150g		Approx.150g	
Accessories	Instruction manual, installation bracket, Four mounting brackets(M2)		Instruction manual	



# Ratings and Specifications (LCD Monitor, Cable)

## LCD Monitor

	FZ-M08
Size	8.4 inches
Type	Liquid crystal color TFT
Resolution	1,024 × 768 dots
Input signal	Analog RGB video input, 1 channel
Power supply voltage	21.6 to 26.4 VDC
Current consumption	Approx. 0.7 A max.
Ambient temperature range	Operating: 0 to 50°C Storage: -25 to 65°C (with no icing or condensation)
Ambient humidity range	Operating and storage: 35% to 85% (with no condensation)
Weight	Approx. 1.2 kg
Accessories	Instruction Sheet and 4 mounting brackets

## Camera Cables

Item	FZ-VS (2m)	FZ-VSB(2m)	FZ-VSL(2m)
Shock resistiveness (durability)	10 to 150Hz single amplitude 0.15mm 3 directions, 8 strokes, 4 times		
Ambient temperature range	Operation and storage: 0 to +65°C (with no icing or condensation)		
Ambient humidity range	Operation and storage: 40 to 70%RH (with no condensation)		
Ambient atmosphere	No corrosive gases		
Material	Cable sheath, connector: PVC		
Minimum bending radius	69mm	81mm	69mm
Weight	approx.170g	approx.220g	approx.170g

## Monitor Cable

Item	FZ-VM
Vibration resistiveness	10 to 150Hz single amplitude 0.15mm 3 directions, 8 strokes, 4 times
Ambient temperature range	Operation: 0 to +50°C; Storage: -20 to +65°C (with no icing or condensation)
Ambient humidity range	Operation and storage: 35 to 85%RH (with no condensation)
Ambient atmosphere	No corrosive gases
Material	Cable sheath: heat-resistant PVC Connector: PVC
Minimum bending radius	75mm
Weight	approx.170g

## Cable Extension Unit

	FZ-VSJ
Power supply voltage (See note 1.)	11.5 to 13.5 VDC
Current consumption (See note 2.)	1.5 A max.
Ambient temperature range	Operating: 0 to 50°C Storage: -25 to 65°C (with no icing or condensation)
Ambient humidity range	Operating and storage: 35% to 85% (with no condensation)
Maximum Units connectable	2 Units per Camera
Weight	Approx. 240 g
Accessories	Instruction Sheet and 4 mounting screws

Note 1: A power supply must be connected to the Strobe Controller and Camera when connecting a FZ-SLC100/SLC15/SZC100/SZC15 and using a Strobe Controller (3Z4S-LT MLEK-C100E1TS2.)

Note 2: The current consumption is when every Camera and Strobe Controller is connected to a power supply.

## Long-distance Camera Cables

Item	FZ-VS2 (15m)	FZ-VSL2(15m)
Shock resistiveness (durability)	10 to 150Hz single amplitude 0.15mm 3 directions, 8 strokes, 4 times	
Ambient temperature range	Operation and storage: 0 to +65°C (with no icing or condensation)	
Ambient humidity range	Operation and storage: 40 to 70%RH (with no condensation)	
Ambient atmosphere	No corrosive gases	
Material	Cable sheath, connector: PVC	
Minimum bending radius	93mm	
Weight	approx.1600g	

## Parallel Cable

Item	FZ-VP
Vibration resistiveness	10 to 150Hz single amplitude 0.15mm 3 directions, 8 strokes, 4 times
Ambient temperature range	Operation: 0 to +50°C; Storage: -20 to +65°C (with no icing or condensation)
Ambient humidity range	Operation and storage: 35 to 85%RH (with no condensation)
Ambient atmosphere	No corrosive gases
Material	Cable sheath: heat-resistant PVC Connector: resin
Minimum bending radius	75mm
Weight	approx.160g

## High-resolution, Low-distortion Lenses

Model	FZ-LEH5	FZ-LEH8	FZ-LEH12	FZ-LEH16	FZ-LEH25	FZ-LEH35	FZ-LEH50	FZ-LEH75	FZ-LEH100
Appearance									
Focal length	5mm	8mm	12.5mm	16mm	25mm	35mm	50mm	75mm	100mm
Brightness	F2.8	F1.4	F1.4	F1.4	F1.4	F2	F2.8	F2.5	F2.8
Filter size	M40.5 P0.5	M27.0 P0.5	M27.0 P0.5	M27.0 P0.5	M27.0 P0.5	M27.0 P0.5	M27.0 P0.5	M34.0 P0.5	M40.5 P0.5

The 5-mm Extension Tubes (3Z4S-LE ML-EXR) cannot be used with FZ-LEH25 Lenses.

## CCTV Lenses

Model	3Z4S-LE ML-0614	3Z4S-LE ML-0813	3Z4S-LE ML-1214	3Z4S-LE ML-1614	3Z4S-LE ML-2514	3Z4S-LE ML-3519	3Z4S-LE ML-5018	3Z4S-LE ML-7527	3Z4S-LE ML-10035
Appearance									
Focal length	6 mm	8 mm	12 mm	16 mm	25 mm	35 mm	50 mm	75 mm	100 mm
Brightness	F1.4	F1.3	F1.4	F1.4	F1.4	F1.9	F1.8	F2.7	F3.5
Filter size	M27 P0.5	M25.5 P0.5	M27 P0.5	M27 P0.5	M27 P0.5	M27 P0.5	M30.5 P0.5	M30.5 P0.5	M30.5 P0.5

## Lenses for small camera

Model	FZ-LES3	FZ-LES6	FZ-LES16	FZ-LES30
Appearance				
Focal length	3mm	6mm	16mm	30mm
Brightness	F2.0	F2.0	F3.4	F3.4

## Extension Tubes

Model	3Z4S-LE ML-EXR
Contents	Set of 7 tubes(40 mm, 20 mm, 10 mm, 5 mm, 2.0 mm, 1.0 mm, and 0.5 mm) Maximum outer diameter: 30 mm dia.

## Extension Tubes for small camera

Model	FZ-LESR
Contents	Set of 3 tubes(15 mm, 10 mm, 5 mm) Maximum outer diameter: 12 mm dia.

•Do not use the 0.5-mm, 1.0-mm, and 2.0-mm Extension Tubes attached to each other. Since these Extension Tubes are placed over the threaded section of the Lens or other Extension Tube, the connection may loosen when more than one 0.5-mm, 1.0-mm or 2.0-mm Extension Tube are used together.

•Reinforcement may be required for combinations of Extension Tubes exceeding 30 mm if the Camera is subject to vibration.

# External Dimensions (Unit:mm)

## FZ3-series Controllers

- LCD-integrated type**  
 FZ3-30□/FZ3-30□-10  
 FZ3-70□/FZ3-70□-10  
 FZ3-H30□/FZ3-H30□-10  
 FZ3-H70□/FZ3-H70□-10

- Box-type**  
 FZ3-35□/FZ3-35□-10  
 FZ3-75□/ FZ3-75□-10  
 FZ3-H35□/ FZ3-H35□-10  
 FZ3-H75□/ FZ3-H75□-10

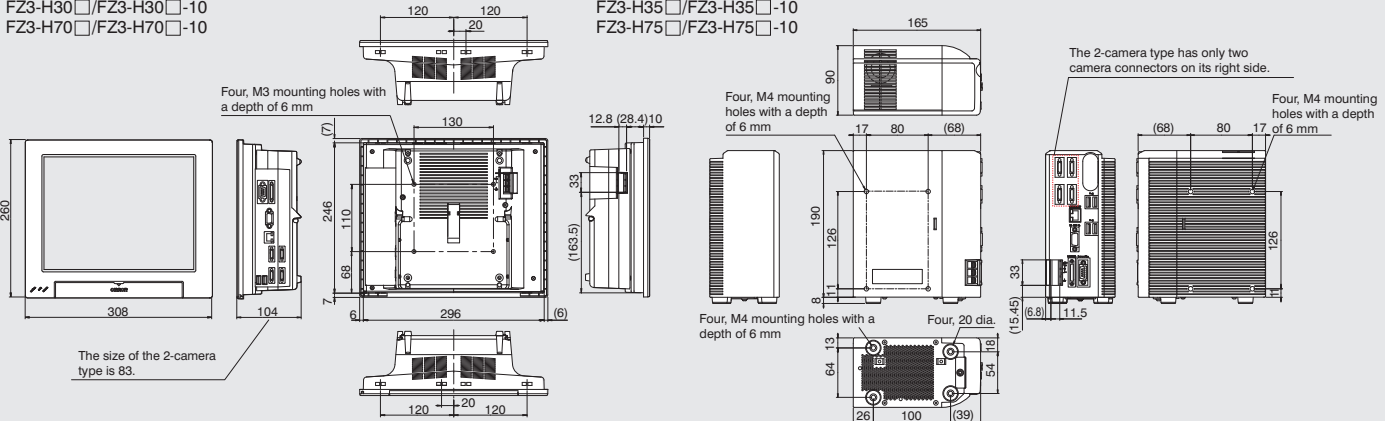

## Cameras

- Intelligent camera**

- Auto focus camera**

FZ-SLC15

FZ-SLC100

FZ-SZC15  
FZ-SZC100

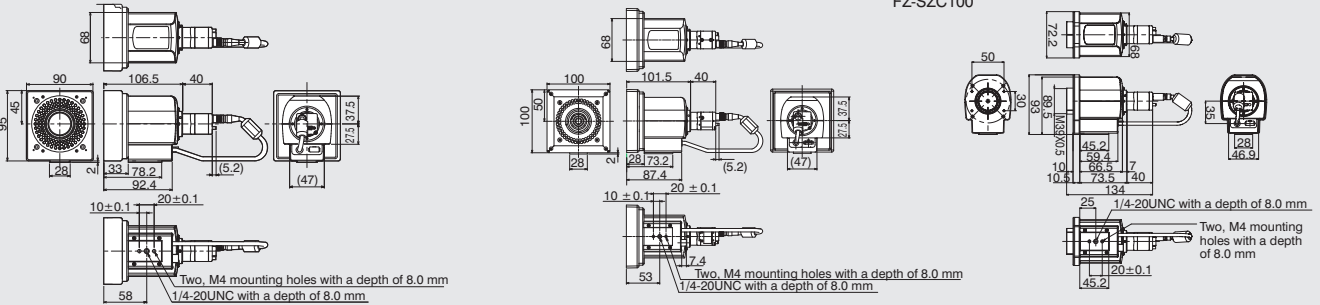

## Digital cameras

- 300,000-pixel camera**

- 2 million-pixel camera**

- 5 million-pixel camera**

FZ-S  
FZ-SC

FZ-S2M  
FZ-SC2M

FZ-S5M  
FZ-SC5M

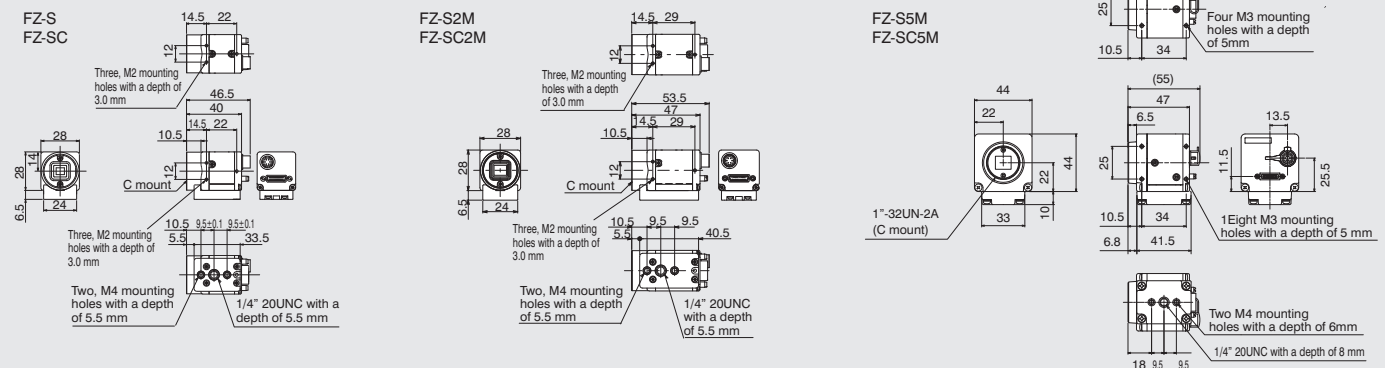

## Small digital cameras

- Camera head**

- Camera amplifier**

Flat camera

Pen-shaped camera

Can be used for both flat cameras and pen-shaped cameras

FZ-SF  
FZ-SFC

FZ-SP  
FZ-SPC

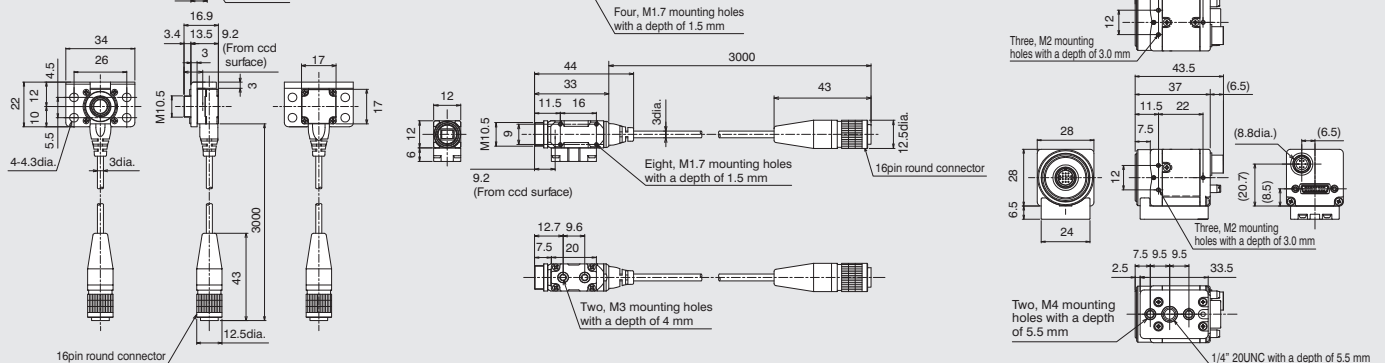

# Cable

## Camera Cable

### ■ Camera Cable(Model FZ-VS)

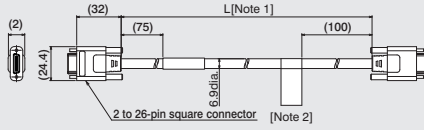

### ■ Long-distance Camera Cable(Model FZ-VS2)

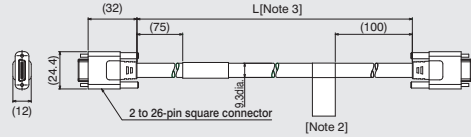

### ■ Bend resistant Cable(Model FZ-VSB)

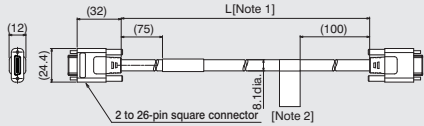

### ■ Long-distance Right-angle Camera Cable(Model FZ-VSL2)

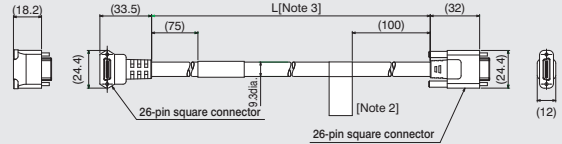

### ■ Right-angle Camera Cable(Model FZ-VSL)

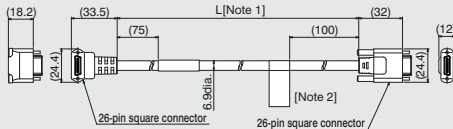

[Note1]: cable is available in 2m/5m/10m.  
 [Note2]: Each camera cables has polarity.  
 Please ensure that the name plate side of the cable is connected to the controller.  
 [Note3]: cable is available in 15m.

## Parallel Cable(Model FZ-VP)

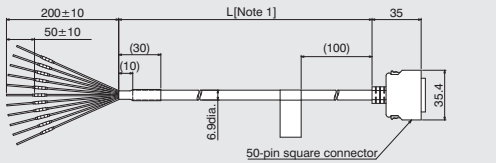

[Note1]: cable is available in 2m/5m.

## Monitor Cable(Model FZ-VM)

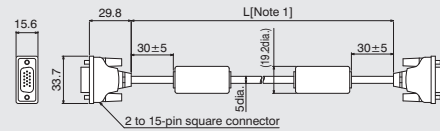

[Note1]: cable is available in 2m/5m.

## LCD Monitor

### ■ FZ-M08

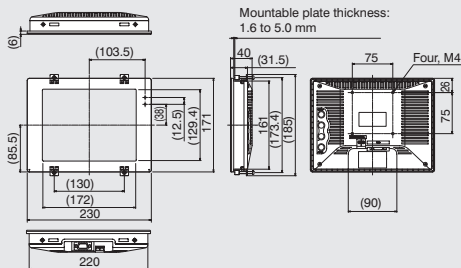

## Camera Cable Extension Unit

### ■ FZ-VSJ

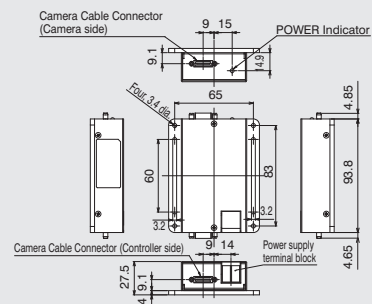

## Lens for small camera

### FZ-LES Series

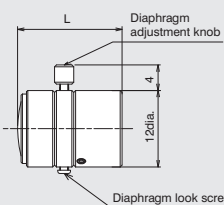

LensesModel	Focal length	Brightness	Maximum outside diameter	Overall length
FZ-LES3	3mm	F2.0	12 dia.	16.4mm
FZ-LES6	6mm	F2.0	12 dia.	19.7mm
FZ-LES16	16mm	F3.4	12 dia.	23.1mm
FZ-LES30	30mm	F3.4	12 dia.	25.5mm

## Extension Tubes for small camera

### FZ-LESR

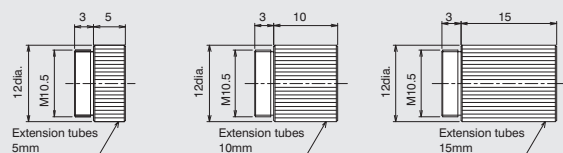

# Optical Chart

## 5 million-pixel digital camera FZ-S □ 5M

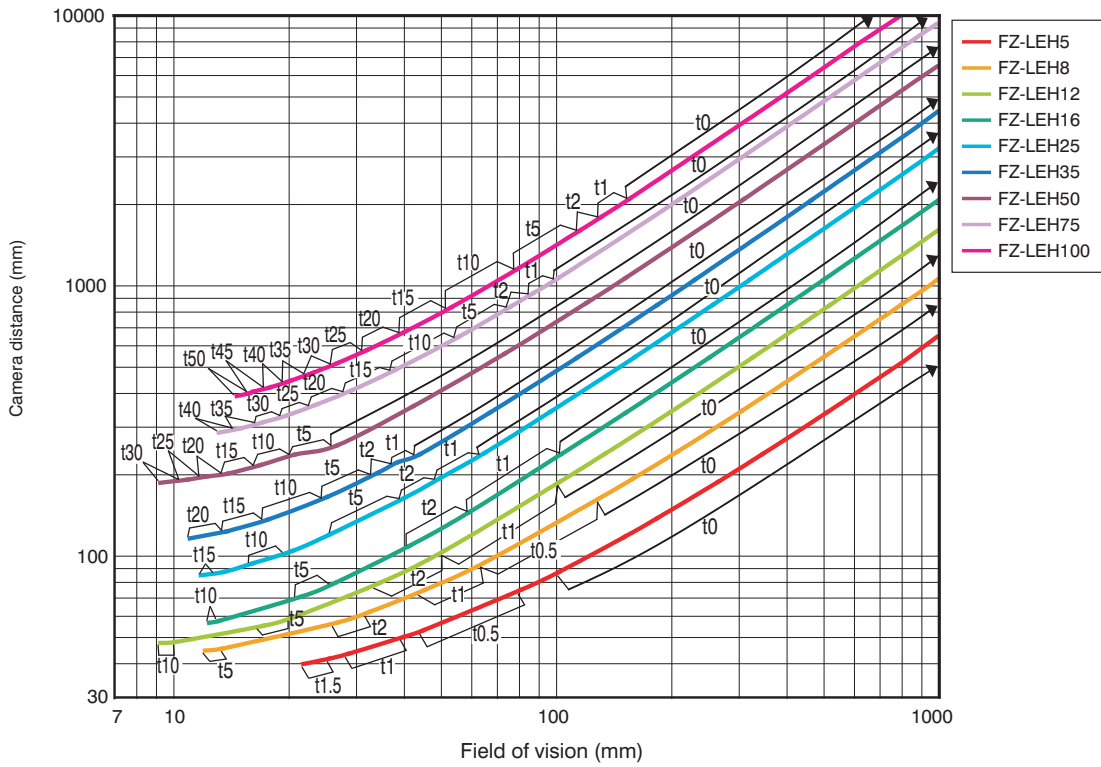

The 5-mm Extension Tubes (3Z4S-LE ML-EXR) cannot be used with FZ-LEH25 Lenses.

## Two-million-pixel digital camera FZ-S □ 2M

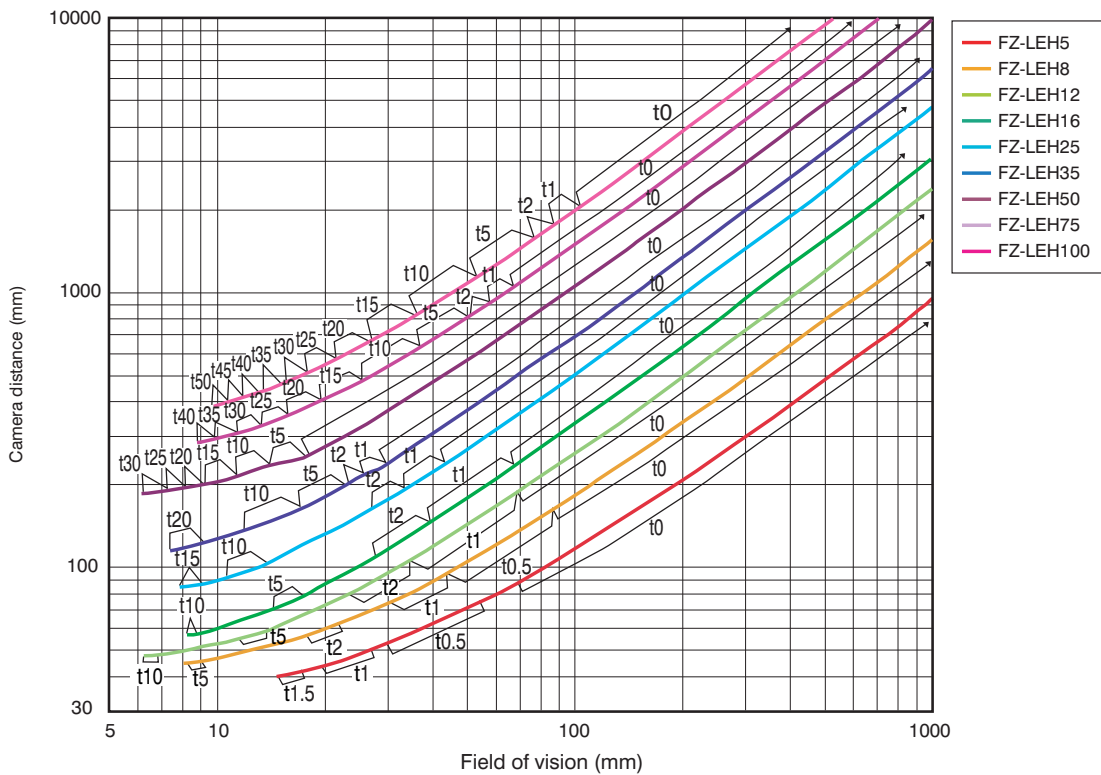

The 5-mm Extension Tubes (3Z4S-LE ML-EXR) cannot be used with FZ-LEH25 Lenses.

**300,000-pixel digital camera FZ-S**

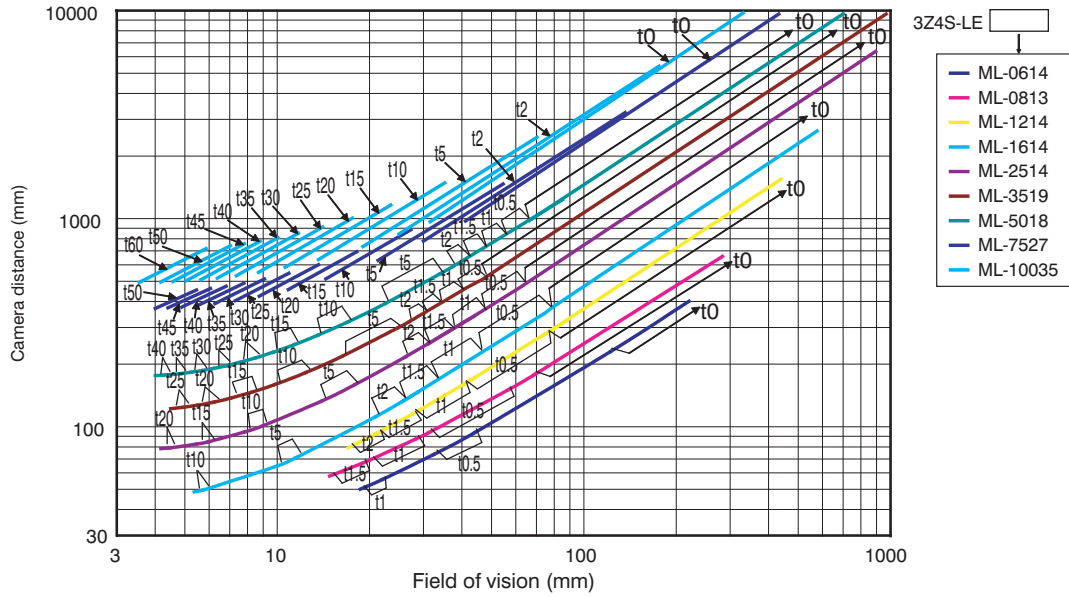

**300,000-pixel small digital cameras FZ-SF, FZ-SP**

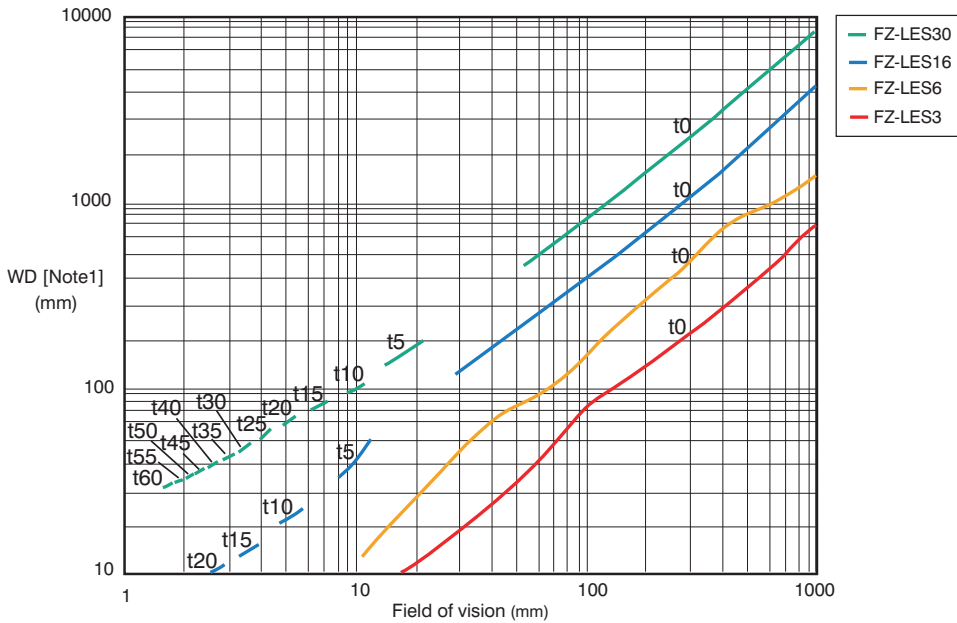

Note1: The vertical axis represents WD, not installation distance.

**Intelligent camera, autofocus camera with wide field of vision FZ-S C100**

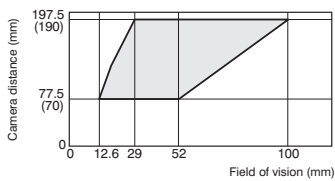

\*The value in parentheses is for the camera installation distance when using an Intelligent Camera.

**with narrow field of vision FZ-S C15**

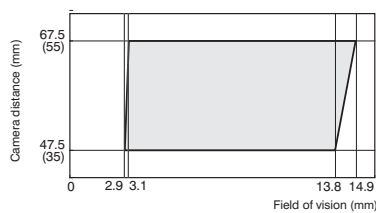

\*The value in parentheses is for the camera installation distance when using an Intelligent Camera.

\*Be sure to check the Instruction Sheet packed with the product before using an Intelligent Camera or Autofocus Camera.





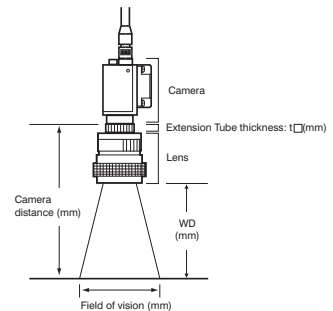















**Meaning of Optical Chart**

The X axis of the optical chart shows the field of vision (mm)(Note1), and the Y axis of the optical chart shows the camera installation distance (mm)(Note2).



































Note1: The lengths of the fields of vision given in the optical charts are the lengths of the Y axis.  
Note2: The vertical axis represents WD for small cameras.

# Processing Items

Group	Icon	Processing Item	Corresponding Page in the Catalog		
Inspections / Measurement		Search	Used to identify the shapes and calculate the position of measurement objects.		
		Flexible Search	Recognizing the shapes of workpieces with variation and detecting their positions.	P14	
		Sensitive Search	Search a small difference by dividing the search model in detail, and calculating the correlation.	P14	
		ECM Search	Used to search the similar part of model form input image. Detect the evaluation value and position.		
		Ec Circle Search	Extract circles using "round " shape information and get position, radius and quantity in high preciseness.	P14	
		Shape Search+	Used to Search the similar part of models from input image. Defect the evaluation value and position.	P14	
		Classification	Used when various kinds of products on the assembly line need to be sorted and identified.		
		Edge Position	Measure position of measurement objects according to the color change in measurement area.		
		Edge Pitch	Detect edges by color change in measurement area. Used for calculating number of pins of IC and connectors.		
		Scan Edge Position	Measure peak/bottom edge position of workpieces according to the color change in separated measurement area.	P14	
		Scan Edge Width	Measure max/min/average width of workpieces according to the color change in separated measurement area.	P14	
		Color Data	Used for detecting presence and mixed varieties of products by using color average and deviation.		
		Gravity and Area	Used to measure area, center of gravity of workpieces by extracting the color to be measured.		
		Labeling	Used to measure number, area and gravity of workpieces by extracting registered color.		
		Label Data	Selecting one region of extracted Labeling, and get that measurement. Area and Gravity position can be got and judged.		
		Labeling+	Extract objects of registered color, and measure many features such as number and circularity.	P14	
		Defect	Used for appearance measurement of plain-color measurement objects such as defects, stains and burrs.	P13	
		PreciseDefect	Check the defect on the object. Parameters for extraction defect can be set precisely.	P13	
		Fine Matching	Difference can be detected by overlapping and comparing(matching) registered fine images with input images.	P13	
		Character Inspection	Recognize character according correlation search with model image registered in [Model Dictionary].	P15	
		Date Verification	Reading character string is verified with internal date.	P15	
		Model Dictionary	Register character pattern as dictionary. The pattern is used in [Character Inspection].	P15	
		Barcode+	Recognize barcode, verify and output decoded characters.	P15	
		2DCode+	Recognize 2D code, verify and output decoded characters.	P15	
		Circle Angle	Used for calculating angle of inclination of circular measurement objects.		
	Image Capturing		Camera Image Input	To input images from cameras. And set up the conditions to input images from cameras.	
			Camera Image Input HDR+	Create high-dynamic range images by acquiring several images with different conditions.	P6
		Camera Switching	To switch the cameras used for measurement. Not input images from cameras again.		
		Measurement Image Switching	To switch the images used for measurement. Not input images from camera again.		

\*The items in red are High Grade processing items.

Group	Icon	Processing Item	Corresponding Page in the Catalog	
Correcting images		Position Compensation	Used when positions are differed. Correct measurement is performed by correcting position of input images.	
		Trapezoidal Correction+	Rectify the trapezoidal deformed image.	P8
		Filtering	Used for processing images input from cameras in order to make them easier to be measured.	
		Background Suppression	To enhance contrast of images by extracting color in specified brightness.	P12
		Color Gray Filter	Color image is converted into monochrome images to emphasize specific color.	
		Extract Color Filter	Convert color image to color extracted image or binary image.	P12
		Anti Color Shading	To remove the irregular color/pattern by uniformizing max.2 specified colors.	P12
		Stripes Removal Filter+	Remove the background pattern of stripes.	P9
		Halation Cut+	Remove halation from input image.	P9
		Panorama+	Combine multiple image to create one big image.	P5
		Polar Transformation	Rectify the image by polar transformation. Useful for OCR or pattern inspection printed on circle.	P12
Assisting inspections / measurement		Calculation	Used when using the judge results and measured values of Procltem which are registered in processing units.	
		Line Regression	Used for calculating regression line from plural measurement coordinate.	P15
		Circle Regression	Used for calculating regression circle from plural measurement coordinate.	P15
		Calibration+	Transform (X,Y) position to the real coordinate system.	P15
		Set Unit Data	Used to change the Procltem data (setting parameters,etc.) that has been set up in a scene.	
		Get Unit Data	Used to get one data (measured results, setting parameters,etc.) of Procltem that has been set up in a scene.	
		Set Unit Figure	Used for re-setting the figure data (model, measurement area ) registered in an unit.	
		Get Unit Figure	Used for get the figure data (model, measurement area ) registered in an unit.	
		Trend Monitor	Used for displaying the information about results on the monitor, facilitating to avoid NG and analyze causes.	P17
		Image Logging	Used for saving the measurement images to the memory and USB memory.	P17
		Data Logging	Used for saving the measurement data to the memory and USB memory.	
		Elapsed Time	Used for calculating the elapsed time since the measurement trigger input.	
	Wait	Processing is stopped only at the set time. The standby time is set by the unit of [ms].		
Branching processing		Conditional Branch	Used where more than two kinds of products on the production line need to detected separately.	P16
		End	This Procltem must be set up as the last processing unit of a branch.	
		DI Branch	Same as Procltem "Branch". But you can change the targets of conditional branching via external inputs.	P16
Outputting results		Data Output	Used when you need to output data to the external devices such as PLC or PC via serial ports.	P15
		Parallel Data Output	Used when you need to output data to the external devices such as PLC or PC via parallel ports.	
		Parallel Judgement Output	Used when you need to output judgement results to the external devices such as PLC or PC via parallel ports.	
Displaying results on the monitor		Result Display	Used for displaying the texts or the figures in the camera image .	
		Display Image File	Display selected image file.	
		Display Last NG Image	Display the last NG images.	P17

This document provides information mainly for selecting suitable models. Please read the document User's Manual (Z283) carefully for information that the user must understand and accept before purchase, including information on warranty, limitations of liability, and precautions.

**OMRON Corporation**  
**Industrial Automation Company**  
**Sensing Devices Division H.Q.**  
**Application Sensors Division**

Shiokoji Horikawa, Shimogyo-ku,  
Kyoto, 600-8530 Japan  
Tel: (81)75-344-7068/Fax: (81)75-344-7107

**Regional Headquarters**

**OMRON EUROPE B.V.**

**Sensor Business Unit**

Carl-Benz-Str. 4, D-71154 Nufringen,  
Germany  
Tel: (49) 7032-811-0/Fax: (49) 7032-811-199

**OMRON ELECTRONICS LLC**

One Commerce Drive Schaumburg,  
IL 60173-5302 U.S.A.  
Tel: (1) 847-843-7900/Fax: (1) 847-843-7787

**OMRON ASIA PACIFIC PTE. LTD.**

No. 438A Alexandra Road # 05-05/08 (Lobby 2),  
Alexandra Technopark, Singapore 119967  
Tel: (65) 6835-3011/Fax: (65) 6835-2711

**OMRON (CHINA) CO., LTD.**

Room 2211, Bank of China Tower,  
200 Yin Cheng Zhong Road,  
PuDong New Area, Shanghai, 200120, China  
Tel: (86) 21-5037-2222/Fax: (86) 21-5037-2200

**Authorized Distributor:**

© OMRON Corporation 2008 All Rights Reserved.  
In the interest of product improvement,  
specifications are subject to change without notice.